



FCC RF Test Report

APPLICANT : Motorola Mobility LLC
EQUIPMENT : Mobile Cellular Phone
BRAND NAME : Motorola
MODEL NAME : XT2075-2
FCC ID : IHDT56ZC2
STANDARD : 47 CFR Part 2, 22, 24, 27
CLASSIFICATION : PCS Licensed Transmitter Held to Ear (PCE)

The product was received on May 27, 2020 and completely tested on Jul. 15, 2020. We, Sporton International (ShenZhen) Inc., would like to declare that the tested sample has been evaluated in accordance with the procedures given in ANSI C63.26-2015 and shown compliance with the applicable technical standards.

The test results in this report apply exclusively to the tested model / sample. Without written approval of Sporton International (ShenZhen) Inc., the test report shall not be reproduced except in full.

Jason Jia

Reviewed by: Jason Jia / Supervisor

James Huang

Approved by: James Huang / Manager



Sporton International (Kunshan) Inc.

**No. 1098, Pengxi North Road, Kunshan Economic Development Zone Jiangsu Province 215300
People's Republic of China**



TABLE OF CONTENTS

REVISION HISTORY... 3
SUMMARY OF TEST RESULT ... 4
1 GENERAL DESCRIPTION ... 5
1.1 Applicant ... 5
1.2 Manufacturer ... 5
1.3 Product Feature of Equipment Under Test ... 5
1.4 Product Specification of Equipment Under Test ... 6
1.5 Modification of EUT ... 6
1.6 Maximum ERP/EIRP Power, Frequency Tolerance, and Emission Designator ... 7
1.7 Testing Location ... 13
1.8 Test Software ... 13
1.9 Applicable Standards ... 13
2 TEST CONFIGURATION OF EQUIPMENT UNDER TEST ... 14
2.1 Test Mode ... 14
2.2 Connection Diagram of Test System ... 14
2.3 Support Unit used in test configuration and system ... 15
2.4 Measurement Results Explanation Example ... 15
2.5 Frequency List of Low/Middle/High Channels ... 16
3 CONDUCTED TEST ITEMS ... 19
3.1 Measuring Instruments ... 19
3.2 Test Setup ... 19
3.3 Test Result of Conducted Test ... 19
3.4 Conducted Output Power and ERP/EIRP ... 20
3.5 Peak-to-Average Ratio ... 21
3.6 Occupied Bandwidth ... 22
3.7 Conducted Band Edge ... 23
3.8 Conducted Spurious Emission ... 25
3.9 Frequency Stability ... 26
4 RADIATED TEST ITEMS ... 27
4.1 Measuring Instruments ... 27
4.2 Test Setup ... 27
4.3 Test Result of Radiated Test ... 27
4.4 Radiated Spurious Emission ... 28
5 LIST OF MEASURING EQUIPMENT ... 29
6 UNCERTAINTY OF EVALUATION ... 30
APPENDIX A. TEST RESULTS OF CONDUCTED TEST
APPENDIX B. TEST RESULTS OF RADIATED TEST
APPENDIX C. TEST SETUP PHOTOGRAPHS



SUMMARY OF TEST RESULT

Report Section	FCC Rule	Description	Limit	Result	Remark
3.4	§2.1046	Conducted Output Power	Reporting Only	PASS	-
	§22.913(a)(5)	Effective Radiated Power (5G NR n5)	ERP < 7 Watt		
	§27.50(c)(10)	Effective Radiated Power (5G NR n71)	ERP < 3 Watt		
	§24.232(c) §27.50(h)(2)	Equivalent Isotropic Radiated Power (5G NR n2) (5G NR n25) (5G NR n41)	EIRP < 2Watt		
	§27.50(d)(4)	Equivalent Isotropic Radiated Power (5G NR n66)	EIRP < 1Watt		
3.5	§24.232(d)	Peak-to-Average Ratio	<13 dB	PASS	-
3.6	§2.1049	Occupied Bandwidth	Reporting Only	PASS	-
3.7	§2.1051 §22.917(a) §24.238(a) §27.53(g)	Conducted Band Edge Measurement (5G NR n2) (5G NR n5) (5G NR n25) (5G NR n66) (5G NR n71)	< 43+10log ₁₀ (P[Watts])	PASS	-
	§27.53(m)(4)	Conducted Band Edge Measurement (5G NR n41)	§27.53(m)(4)		
3.8	§2.1051 §22.917(a) §24.238(a) §27.53(g)	Conducted Spurious Emission (5G NR n2) (5G NR n5) (5G NR n25) (5G NR n66) (5G NR n71)	< 43+10log ₁₀ (P[Watts])	PASS	-
	§2.1051 §27.53(m)(4)	Conducted Spurious Emission (5G NR n41)	< 55+10log ₁₀ (P[Watts])		
3.9	§2.1055 §22.355	Frequency Stability Temperature & Voltage	< 2.5 ppm for Part 22	PASS	-
	§2.1055 §24.235 §27.54		Within Authorized Band		
4.4	§2.1053 §22.917(a) §24.238(a) §27.53(g)	Radiated Spurious Emission (5G NR n2) (5G NR n5) (5G NR n25) (5G NR n66) (5G NR n71)	< 43+10log ₁₀ (P[Watts])	PASS	Under limit 30.63 dB at 10602.000 MHz
	§2.1053 §27.53(m)(4)	Radiated Spurious Emission (5G NR n41)	< 55+10log ₁₀ (P[Watts])		



1 General Description

1.1 Applicant

Motorola Mobility LLC
222 W, Merchandise Mart Plaza, Chicago IL 60654 USA

1.2 Manufacturer

Motorola Mobility LLC
222 W, Merchandise Mart Plaza, Chicago IL 60654 USA

1.3 Product Feature of Equipment Under Test

Product Feature	
Equipment	Mobile Cellular Phone
Brand Name	Motorola
Model Name	XT2075-2
FCC ID	IHDT56ZC2
EUT supports Radios application	CDMA/GSM/WCDMA/LTE/5G NR WLAN 2.4GHz 802.11b/g/n HT20 WLAN 5GHz 802.11a/n HT20/HT40 WLAN 5GHz 802.11ac VHT20/VHT40/VHT80 Bluetooth BR / EDR / LE FM Receiver/GNSS/NFC
IMEI Code	Conducted : N/A Radiation : 353613110012518
HW Version	DVT2
SW Version	QPN30.37
EUT Stage	Identical Prototype

Remark:

1. Only 5G NR bands are tested in this report, all the other RF bands are tested in the other reports separately.
2. 5G NR supports CP-OFDM and DFT-s-OFDM modulation, for DFT-s-OFDM power is higher than CP-OFDM, so chose DFT-s-OFDM modulation to perform all test.
3. 5G NR supports NSA mode, not support SA mode, all NSA mode refer to Product Specification.
4. 5G NR n41 supports HPUE.



1.4 Product Specification of Equipment Under Test

Standards-related Product Specification	
Tx Frequency	5G NR n2: 1852.5 MHz ~ 1907.5 MHz 5G NR n5: 826.5 MHz ~ 846.5 MHz 5G NR n25: 1852.5 MHz ~ 1912.5 MHz 5G NR n41: 2506.02 MHz ~ 2679.99 MHz 5G NR n66: 1712.5 MHz ~ 1777.5 MHz 5G NR n71: 665.5 MHz ~ 695.5MHz
Rx Frequency	5G NR n2: 1932.5 MHz ~ 1987.5 MHz 5G NR n5: 871.5 MHz ~ 891.5 MHz 5G NR n25: 1932.5 MHz ~ 1992.5 MHz 5G NR n41: 2506.02 MHz ~ 2679.99 MHz 5G NR n66: 2112.5 MHz~ 2197.5 MHz 5G NR n71: 619.5 MHz ~ 649.5MHz
Bandwidth	n2, n5, n25, n66, n71: 5MHz / 10MHz / 15MHz / 20MHz n41 : 20MHz / 40MHz / 50MHz / 60MHz / 80MHz / 90MHz / 100MHz
SCS	n2, n5, n25, n66, n71: 15KHz n41 : 30KHz
Antenna Gain	n2 / n25 / n66 : -2.00 dBi n5 / n41 / n71 : -3.00 dBi
Type of Modulation	CP-OFDM: QPSK / 16QAM / 64QAM / 256QAM DFT-s-OFDM: PI/2 BPSK / QPSK / 16QAM / 64QAM / 256QAM

1.5 Modification of EUT

No modifications are made to the EUT during all test items.



1.6 Maximum ERP/EIRP Power, Frequency Tolerance, and Emission Designator

5G NR n2		PI/2 BPSK		QPSK	
BW (MHz)	Frequency Range (MHz)	Emission Designator (99%OBW)	Maximum EIRP(W)	Emission Designator (99%OBW)	Maximum EIRP(W)
5	1852.5 ~ 1907.5	4M48F9W	0.1309	4M52G7D	0.1346
10	1855.0 ~ 1905.0	9M07F9W	0.1330	9M05G7D	0.1346
15	1857.5 ~ 1902.5	13M5F9W	0.1361	13M5G7D	0.1371
20	1860.0 ~ 1900.0	18M3F9W	0.1469	18M4G7D	0.1303
5G NR n2		16QAM		64QAM	
BW (MHz)	Frequency Range (MHz)	Emission Designator (99%OBW)	Maximum EIRP(W)	Emission Designator (99%OBW)	Maximum EIRP(W)
5	1852.5 ~ 1907.5	4M49W7D	0.1079	4M50W7D	0.0769
10	1855.0 ~ 1905.0	9M09W7D	0.1102	9M07W7D	0.0759
15	1857.5 ~ 1902.5	13M5W7D	0.1143	13M5W7D	0.0796
20	1860.0 ~ 1900.0	18M5W7D	0.1138	18M4W7D	0.0778
5G NR n2		256QAM			
BW (MHz)	Frequency Range (MHz)	Emission Designator (99%OBW)		Maximum EIRP(W)	
5	1852.5 ~ 1907.5	4M50W7D		0.0488	
10	1855.0 ~ 1905.0	9M05W7D		0.0479	
15	1857.5 ~ 1902.5	13M5W7D		0.0498	
20	1860.0 ~ 1900.0	18M3W7D		0.0493	
Frequency Tolerance (ppm)		0.0021			



5G NR n5		PI/2 BPSK		QPSK	
BW (MHz)	Frequency Range (MHz)	Emission Designator (99%OBW)	Maximum ERP(W)	Emission Designator (99%OBW)	Maximum ERP(W)
5	826.5 ~ 846.5	4M49F9W	0.0819	4M49G7D	0.0854
10	829.0 ~ 844.0	9M07F9W	0.0882	9M05G7D	0.0821
15	831.5 ~ 841.5	13M5F9W	0.0840	13M5G7D	0.0830
20	834.0 ~ 839.0	18M6F9W	0.0900	18M4G7D	0.0852
5G NR n5		16QAM		64QAM	
BW (MHz)	Frequency Range (MHz)	Emission Designator (99%OBW)	Maximum ERP(W)	Emission Designator (99%OBW)	Maximum ERP(W)
5	826.5 ~ 846.5	4M50W7D	0.0697	4M50W7D	0.0480
10	829.0 ~ 844.0	9M07W7D	0.0686	9M05W7D	0.0470
15	831.5 ~ 841.5	13M5W7D	0.0686	13M5W7D	0.0551
20	834.0 ~ 839.0	18M5W7D	0.0697	18M3W7D	0.0464
5G NR n5		256QAM			
BW (MHz)	Frequency Range (MHz)	Emission Designator (99%OBW)		Maximum ERP(W)	
5	826.5 ~ 846.5	4M50W7D		0.0284	
10	829.0 ~ 844.0	9M05W7D		0.0286	
15	831.5 ~ 841.5	13M5W7D		0.0465	
20	834.0 ~ 839.0	18M3W7D		0.0301	
Frequency Tolerance (ppm)		0.0025			



5G NR n25		PI/2 BPSK		QPSK	
BW (MHz)	Frequency Range (MHz)	Emission Designator (99%OBW)	Maximum EIRP(W)	Emission Designator (99%OBW)	Maximum EIRP(W)
5	1852.5 ~ 1912.5	4M48F9W	0.1435	4M51G7D	0.1426
10	1855.0 ~ 1910.0	9M05F9W	0.1489	9M05G7D	0.1459
15	1857.5 ~ 1907.5	13M5F9W	0.1479	13M5G7D	0.1466
20	1860.0 ~ 1905.0	18M5F9W	0.1507	18M3G7D	0.1483
5G NR n25		16QAM		64QAM	
BW (MHz)	Frequency Range (MHz)	Emission Designator (99%OBW)	Maximum EIRP(W)	Emission Designator (99%OBW)	Maximum EIRP(W)
5	1852.5 ~ 1912.5	4M50W7D	0.1135	4M53W7D	0.0794
10	1855.0 ~ 1910.0	9M07W7D	0.1156	9M05W7D	0.0794
15	1857.5 ~ 1907.5	13M5W7D	0.1161	13M5W7D	0.0804
20	1860.0 ~ 1905.0	18M4W7D	0.1159	18M4W7D	0.0824
5G NR n25		256QAM			
BW (MHz)	Frequency Range (MHz)	Emission Designator (99%OBW)		Maximum EIRP(W)	
5	1852.5 ~ 1912.5	4M50W7D		0.0491	
10	1855.0 ~ 1910.0	9M09W7D		0.0500	
15	1857.5 ~ 1907.5	13M5W7D		0.0506	
20	1860.0 ~ 1905.0	18M3W7D		0.0516	
Frequency Tolerance (ppm)		0.0025			



5G NR n41		PI/2 BPSK		QPSK	
BW (MHz)	Frequency Range (MHz)	Emission Designator (99%OBW)	Maximum EIRP(W)	Emission Designator (99%OBW)	Maximum EIRP(W)
20	2506.02 ~ 2679.99	18M4F9W	0.2198	18M6G7D	0.2143
40	2516.01 ~ 2670.00	36M0F9W	0.2297	36M3G7D	0.2173
50	2521.02 ~ 2664.99	46M5F9W	0.2198	46M4G7D	0.2095
60	2526.00 ~ 2659.98	59M0F9W	0.2198	58M1G7D	0.2203
80	2536.02 ~ 2649.99	77M8F9W	0.2388	78M0G7D	0.2109
90	2541.00 ~ 2644.98	86M1F9W	0.1910	86M0G7D	0.1867
100	2546.01 ~ 2640.00	97M5F9W	0.1955	96M7G7D	0.1846
5G NR n41		16QAM		64QAM	
BW (MHz)	Frequency Range (MHz)	Emission Designator (99%OBW)	Maximum EIRP(W)	Emission Designator (99%OBW)	Maximum EIRP(W)
20	2506.02 ~ 2679.99	18M6W7D	0.1804	18M7W7D	0.1514
40	2516.01 ~ 2670.00	36M0W7D	0.1977	36M0W7D	0.1292
50	2521.02 ~ 2664.99	46M4W7D	0.1816	46M2W7D	0.1310
60	2526.00 ~ 2659.98	59M1W7D	0.1816	58M7W7D	0.1301
80	2536.02 ~ 2649.99	77M8W7D	0.1799	78M0W7D	0.1259
90	2541.00 ~ 2644.98	86M5W7D	0.1532	85M8W7D	0.1060
100	2546.01 ~ 2640.00	97M1W7D	0.1420	96M7W7D	0.1045
5G NR n41		256QAM			
BW (MHz)	Frequency Range (MHz)	Emission Designator (99%OBW)		Maximum EIRP(W)	
20	2506.02 ~ 2679.99	18M6W7D		0.1334	
40	2516.01 ~ 2670.00	36M0W7D		0.0861	
50	2521.02 ~ 2664.99	46M2W7D		0.0817	
60	2526.00 ~ 2659.98	58M9W7D		0.0798	
80	2536.02 ~ 2649.99	78M0W7D		0.0800	
90	2541.00 ~ 2644.98	86M0W7D		0.0664	
100	2546.01 ~ 2640.00	97M1W7D		0.0648	
Frequency Tolerance (ppm)		0.0023			



5G NR n66		PI/2 BPSK		QPSK	
BW (MHz)	Frequency Range (MHz)	Emission Designator (99%OBW)	Maximum EIRP(W)	Emission Designator (99%OBW)	Maximum EIRP(W)
5	1712.5 ~ 1777.5	4M51F9W	0.1352	4M52G7D	0.1315
10	1715.0 ~ 1775.0	9M09F9W	0.1340	9M05G7D	0.1318
15	1717.5 ~ 1772.5	13M5F9W	0.1400	13M6G7D	0.1368
20	1720.0 ~ 1770.0	18M5F9W	0.1507	18M4G7D	0.1384
5G NR n66		16QAM		64QAM	
BW (MHz)	Frequency Range (MHz)	Emission Designator (99%OBW)	Maximum EIRP(W)	Emission Designator (99%OBW)	Maximum EIRP(W)
5	1712.5 ~ 1777.5	4M50W7D	0.1084	4M52W7D	0.0748
10	1715.0 ~ 1775.0	9M07W7D	0.1050	9M05W7D	0.0743
15	1717.5 ~ 1772.5	13M6W7D	0.1086	13M5W7D	0.0773
20	1720.0 ~ 1770.0	18M5W7D	0.1084	18M3W7D	0.0766
5G NR n66		256QAM			
BW (MHz)	Frequency Range (MHz)	Emission Designator (99%OBW)		Maximum EIRP(W)	
5	1712.5 ~ 1777.5	4M51W7D		0.0472	
10	1715.0 ~ 1775.0	9M05W7D		0.0469	
15	1717.5 ~ 1772.5	13M5W7D		0.0485	
20	1720.0 ~ 1770.0	18M4W7D		0.0476	
Frequency Tolerance (ppm)		0.0035			



5G NR n71		PI/2 BPSK		QPSK	
BW (MHz)	Frequency Range (MHz)	Emission Designator (99%OBW)	Maximum ERP(W)	Emission Designator (99%OBW)	Maximum ERP(W)
5	665.5 ~ 695.5	4M47F9W	0.0729	4M52G7D	0.0692
10	668.0 ~ 693.0	9M07F9W	0.0708	9M05G7D	0.0681
15	670.5 ~ 690.5	13M5F9W	0.0692	13M5G7D	0.0671
20	673.0 ~ 688.0	18M4F9W	0.0708	18M3G7D	0.0687
5G NR n71		16QAM		64QAM	
BW (MHz)	Frequency Range (MHz)	Emission Designator (99%OBW)	Maximum ERP(W)	Emission Designator (99%OBW)	Maximum ERP(W)
5	665.5 ~ 695.5	4M51W7D	0.0553	4M50W7D	0.0390
10	668.0 ~ 693.0	9M05W7D	0.0533	9M03W7D	0.0378
15	670.5 ~ 690.5	13M6W7D	0.0525	13M5W7D	0.0378
20	673.0 ~ 688.0	18M6W7D	0.0540	18M3W7D	0.0378
5G NR n71		256QAM			
BW (MHz)	Frequency Range (MHz)	Emission Designator (99%OBW)		Maximum ERP(W)	
5	665.5 ~ 695.5	4M48W7D		0.0246	
10	668.0 ~ 693.0	9M05W7D		0.0235	
15	670.5 ~ 690.5	13M5W7D		0.0235	
20	673.0 ~ 688.0	18M3W7D		0.0254	
Frequency Tolerance (ppm)		0.0041			



1.7 Testing Location

Sporton International (Kunshan) Inc. is accredited to ISO/IEC 17025:2017 by American Association for Laboratory Accreditation with Certificate Number 5145.02.

Test Firm	Sporton International (Kunshan) Inc.		
Test Site Location	No. 1098, Pengxi North Road, Kunshan Economic Development Zone Jiangsu Province 215300 People's Republic of China TEL : +86-512-57900158 FAX : +86-512-57900958		
Test Site No.	Sporton Site No.	FCC Designation No.	FCC Test Firm Registration No.
	03CH04-KS TH01-KS	CN1257	314309

1.8 Test Software

Item	Site	Manufacture	Name	Version
1.	03CH04-KS	AUDIX	E3	6.2009-8-24a

1.9 Applicable Standards

According to the specifications of the manufacturer, the EUT must comply with the requirements of the following standards:

- 47 CFR Part 2, 22, 24, 27
- ANSI C63.26-2015
- FCC KDB 971168 D01 Power Meas License Digital Systems v03r01
- FCC KDB 412172 D01 Determining ERP and EIRP v01r01

Remark:

All test items were verified and recorded according to the standards and without any deviation during the test.



2 Test Configuration of Equipment Under Test

2.1 Test Mode

Antenna port conducted and radiated test items are performed according to KDB 971168 D01 Power Meas License Digital Systems v03r01 with maximum output power.

For radiated measurement, pre-scanned in three orthogonal panels, X, Y, Z. The worst cases (Y plane) were recorded in this report.

The device is investigated from 30MHz to 10 times of fundamental signal for radiated spurious emission test under different RB size/offset and modulations in exploratory test. Subsequently, only the worst case emissions are reported.

	X Plane	Y Plane	Z Plane
Orthogonal Planes of EUT			

2.2 Connection Diagram of Test System

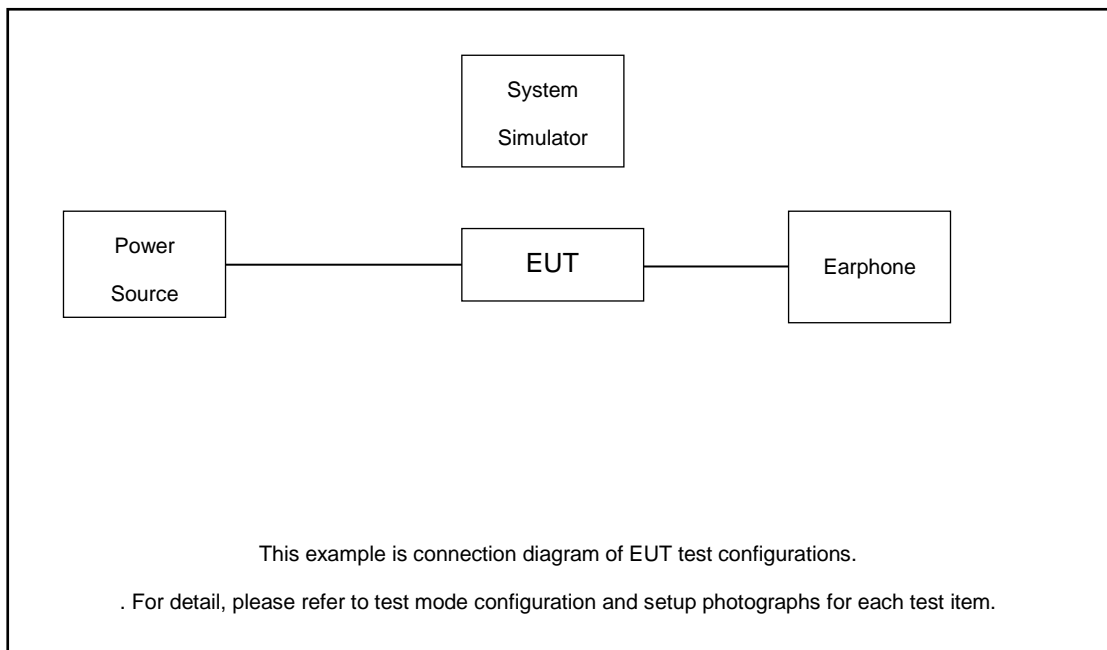



2.3 Support Unit used in test configuration and system

Item	Equipment	Trade Name	Model No.	FCC ID	Data Cable	Power Cord
1.	DC Power Supply	GW	GPS-3030D	N/A	N/A	Unshielded, 1.8 m
2.	NR Base Station	Keysight	E7515B	N/A	N/A	Unshielded, 1.8 m
3.	Fixture	INTEL	NGFF Card Carrier	N/A	N/A	N/A
4.	Earphone	N/A	N/A	N/A	N/A	N/A

2.4 Measurement Results Explanation Example

For all conducted test items:

The offset level is set in the spectrum analyzer to compensate the RF cable loss between EUT conducted output port and spectrum analyzer. With the offset compensation, the spectrum analyzer reading level is exactly the EUT RF output level.

The spectrum analyzer offset is derived from RF cable loss.

$$\text{Offset} = \text{RF cable loss.}$$

Following shows an offset computation example with cable loss 5.8 dB.

Example :

$$\begin{aligned} \text{Offset(dB)} &= \text{RF cable loss(dB)}. \\ &= 5.8 \text{ (dB)} \end{aligned}$$



2.5 Frequency List of Low/Middle/High Channels

5G NR n2 Channel and Frequency List				
BW [MHz]	Channel/Frequency(MHz)	Lowest	Middle	Highest
20	Channel	372000	376000	380000
	Frequency	1860	1880	1900
15	Channel	371500	376000	380500
	Frequency	1857.5	1880	1902.5
10	Channel	371000	376000	381000
	Frequency	1855	1880	1905
5	Channel	370500	376000	381500
	Frequency	1852.5	1880	1907.5

5G NR n5 Channel and Frequency List				
BW [MHz]	Channel/Frequency(MHz)	Lowest	Middle	Highest
20	Channel	166800	167300	167800
	Frequency	834	836.5	839
15	Channel	166300	167300	168300
	Frequency	831.5	836.5	841.5
10	Channel	165800	167300	168800
	Frequency	829	836.5	844
5	Channel	165300	167300	169300
	Frequency	826.5	836.5	846.5

5G NR n25 Channel and Frequency List				
BW [MHz]	Channel/Frequency(MHz)	Lowest	Middle	Highest
20	Channel	372000	376500	381000
	Frequency	1860	1882.5	1905
15	Channel	371500	376500	381500
	Frequency	1857.5	1882.5	1907.5
10	Channel	371000	376500	382000
	Frequency	1855	1882.5	1910
5	Channel	370500	376500	382500
	Frequency	1852.5	1882.5	1912.5



5G NR n41 Channel and Frequency List				
BW [MHz]	Channel/Frequency(MHz)	Lowest	Middle	Highest
100	Channel	509202	518598	528000
	Frequency	2546.01	2592.99	2640
90	Channel	508200	518598	528996
	Frequency	2541	2592.99	2644.98
80	Channel	507204	518598	529998
	Frequency	2536.02	2592.99	2649.99
60	Channel	505200	518598	531996
	Frequency	2526	2592.99	2659.98
50	Channel	504204	518598	532998
	Frequency	2521.02	2592.99	2664.99
40	Channel	503202	518598	534000
	Frequency	2516.01	2592.99	2670
20	Channel	501204	518598	535998
	Frequency	2506.02	2592.99	2679.99

5G NR n66 Channel and Frequency List				
BW [MHz]	Channel/Frequency(MHz)	Lowest	Middle	Highest
20	Channel	344000	349000	354000
	Frequency	1720	1745	1770
15	Channel	343500	349000	354500
	Frequency	1717.5	1745	1772.5
10	Channel	343000	349000	355000
	Frequency	1715	1745	1775
5	Channel	342500	349000	355500
	Frequency	1712.5	1745	1777.5



5G NR n71 Channel and Frequency List				
BW [MHz]	Channel/Frequency(MHz)	Lowest	Middle	Highest
20	Channel	134600	136100	137600
	Frequency	673	680.5	688
15	Channel	134100	136100	138100
	Frequency	670.5	680.5	690.5
10	Channel	133600	136100	138600
	Frequency	668	680.5	693
5	Channel	133100	136100	139100
	Frequency	665.5	680.5	695.5

3 Conducted Test Items

3.1 Measuring Instruments

See list of measuring instruments of this test report.

3.2 Test Setup

3.2.1 Conducted Output Power

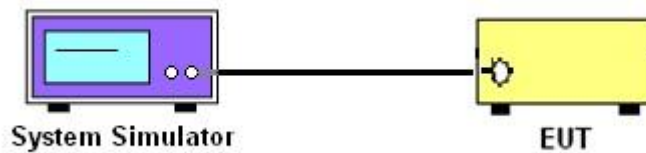

3.2.2 Peak-to-Average Ratio, Occupied Bandwidth ,Conducted Band-Edge and Conducted Spurious Emission

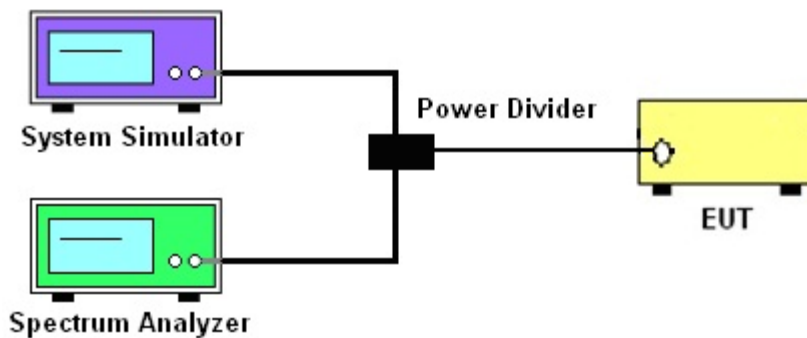

3.2.3 Frequency Stability

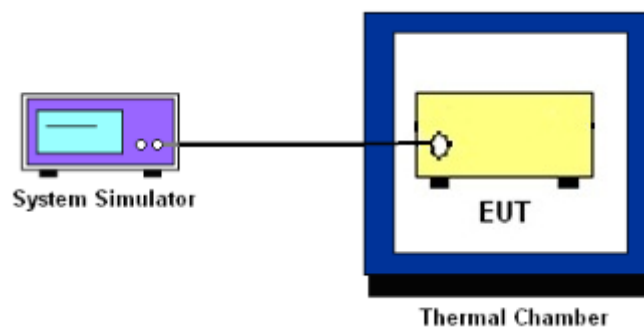

3.3 Test Result of Conducted Test

Please refer to Appendix A.



3.4 Conducted Output Power and ERP/EIRP

3.4.1 Description of the Conducted Output Power Measurement and ERP/EIRP Measurement

A system simulator was used to establish communication with the EUT. Its parameters were set to force the EUT transmitting at maximum output power. The measured power in the radio frequency on the transmitter output terminals shall be reported.

The ERP of mobile transmitters must not exceed 7 Watts for 5G NR n5.

The ERP of mobile transmitters must not exceed 3 Watts for 5G NR n71.

The EIRP of mobile transmitters must not exceed 2 Watts for 5G NR n2, n25 and n41.

The EIRP of mobile transmitters must not exceed 1 Watts for 5G NR n66.

According to KDB 412172 D01 Power Approach,

$EIRP = P_T + G_T - L_C$, $ERP = EIRP - 2.15$, where

P_T = transmitter output power in dBm

G_T = gain of the transmitting antenna in dBi

L_C = signal attenuation in the connecting cable between the transmitter and antenna in dB

3.4.2 Test Procedures

1. The testing follows ANSI C63.26 Section 5.2
2. The transmitter output port was connected to the system simulator.
3. Set EUT at maximum power through the system simulator.
4. Select lowest, middle, and highest channels for each band and different modulation.
5. Measure and record the power level from the system simulator.



3.5 Peak-to-Average Ratio

3.5.1 Description of the PAR Measurement

Power Complementary Cumulative Distribution Function (CCDF) curves provide a means for characterizing the power peaks of a digitally modulated signal on a statistical basis. A CCDF curve depicts the probability of the peak signal amplitude exceeding the average power level. Most contemporary measurement instrumentation include the capability to produce CCDF curves for an input signal provided that the instrument's resolution bandwidth can be set wide enough to accommodate the entire input signal bandwidth. In measuring transmissions in this band using an average power technique, the peak-to-average ratio (PAR) of the transmission may not exceed 13 dB.

3.5.2 Test Procedures

1. The testing follows ANSI C63.26 Section 5.2.3.4 (CCDF).
2. The EUT was connected to spectrum and system simulator via a power divider.
3. Set the CCDF (Complementary Cumulative Distribution Function) option in spectrum analyzer.
4. The highest RF powers were measured and recorded the maximum PAPR level associated with a probability of 0.1 %.
5. Record the deviation as Peak to Average Ratio.



3.6 Occupied Bandwidth

3.6.1 Description of Occupied Bandwidth Measurement

The occupied bandwidth is the width of a frequency band such that, below the lower and above the upper frequency limits, the mean powers emitted are each equal to a specified percentage 0.5% of the total mean transmitted power.

The 26 dB emission bandwidth is defined as the frequency range between two points, one above and one below the carrier frequency, at which the spectral density of the emission is attenuated 26 dB below the maximum in-band spectral density of the modulated signal. Spectral density (power per unit bandwidth) is to be measured with a detector of resolution bandwidth equal to approximately 1.0% of the emission bandwidth.

3.6.2 Test Procedures

1. The testing follows ANSI C63.26 Section 5.4
2. The EUT was connected to spectrum analyzer and system simulator via a power divider.
3. The spectrum analyzer center frequency is set to the nominal EUT channel center frequency. The span range for the spectrum analyzer shall be between two and five times the anticipated OBW.
4. The nominal resolution bandwidth (RBW) shall be in the range of 1 to 5 % of the anticipated OBW, and the VBW shall be at least 3 times the RBW.
5. Set the detection mode to peak, and the trace mode to max hold.
6. Determine the reference value: Set the EUT to transmit a modulated signal. Allow the trace to stabilize. Set the spectrum analyzer marker to the highest level of the displayed trace.
(this is the reference value)
7. Determine the “-26 dB down amplitude” as equal to (Reference Value – X).
8. Place two markers, one at the lowest and the other at the highest frequency of the envelope of the spectral display such that each marker is at or slightly below the “-X dB down amplitude” determined in step 6. If a marker is below this “-X dB down amplitude” value it shall be placed as close as possible to this value. The OBW is the positive frequency difference between the two markers.
9. Use the 99 % power bandwidth function of the spectrum analyzer and report the measured bandwidth.



3.7 Conducted Band Edge

3.7.1 Description of Conducted Band Edge Measurement

22.917(a)

For operations in the 824 – 849 MHz band, the FCC limit is $43 + 10\log_{10}(P[\text{Watts}])$ dB below the transmitter power P(Watts) in a 100kHz bandwidth. However, in the 1MHz bands immediately outside and adjacent to the licensee's frequency block, a resolution bandwidth of at least one percent of the emission bandwidth of the fundamental emission of the transmitter may be employed.

24.238 (a)

For operations in the 1850-1910 and 1930-1990 MHz band, the FCC limit is $43 + 10\log_{10}(P[\text{Watts}])$ dB below the transmitter power P(Watts) in a 1MHz bandwidth. However, in the 1 MHz bands immediately outside and adjacent to the frequency block a resolution bandwidth of at least one percent of the emission bandwidth of the fundamental emission of the transmitter may be employed.

27.53 (c)

For operations in the 776-788 MHz band, the FCC limit is $43 + 10\log_{10}(P[\text{Watts}])$ dB below the transmitter power P(Watts) in a 100 kHz bandwidth. However, in the 100 kHz bands immediately outside and adjacent to the frequency block, a resolution bandwidth of at least 30 kHz may be employed. In addition, the power of any unwanted emissions in any 6.25 kHz bandwidth for all frequencies between 763-775 MHz and 793-806 MHz shall be attenuated below the transmitter power, P (dBW), by at least $65 + 10 \log_{10} p(\text{watts})$, dB, for mobile and portable equipment.

27.53 (g)

For operations in the 600MHz band and 698 -746 MHz band, the FCC limit is $43 + 10\log_{10}(P[\text{Watts}])$ dB below the transmitter power P(Watts) in a 100 kHz bandwidth. However, in the 100 kilohertz bands immediately outside and adjacent to a licensee's frequency block, a resolution bandwidth of at least 30 kHz may be employed.



27.53(m)(4)

For mobile digital stations, the attenuation factor shall be not less than $40 + 10 \log (P)$ dB on all frequencies between the channel edge and 5 megahertz from the channel edge, $43 + 10 \log (P)$ dB on all frequencies between 5 megahertz and X megahertz from the channel edge, and $55 + 10 \log (P)$ dB on all frequencies more than X megahertz from the channel edge, where X is the greater of 6 megahertz or the actual emission bandwidth as defined in paragraph (m)(6) of this section. In addition, the attenuation factor shall not be less that $43 + 10 \log (P)$ dB on all frequencies between 2490.5 MHz and 2496 MHz and $55 + 10 \log (P)$ dB at or below 2490.5 MHz. Mobile Satellite Service licensees operating on frequencies below 2495 MHz may also submit a documented interference complaint against BRS licensees operating on channel BRS Channel 1 on the same terms and conditions as adjacent channel BRS or EBS licensees.

3.7.2 Test Procedures

1. The testing follows ANSI C63.26 section 5.7
2. The EUT was connected to spectrum analyzer and system simulator via a power divider.
3. The band edges of low and high channels for the highest RF powers were measured.
4. Set RBW \geq 1% EBW in the 1MHz band immediately outside and adjacent to the band edge.
5. Beyond the 1 MHz band from the band edge, RBW=1MHz was used.
6. Set spectrum analyzer with RMS detector.
7. The RF fundamental frequency should be excluded against the limit line in the operating frequency band.
8. Checked that all the results comply with the emission limit line.

Example:

The limit line is derived from $43 + 10\log(P)$ dB below the transmitter power P(Watts)
 $= P(W) - [43 + 10\log(P)]$ (dB)
 $= [30 + 10\log(P)]$ (dBm) - $[43 + 10\log(P)]$ (dB) = -13dBm.

9. For 5G NR n41, the other 40 dB, and 55 dB have additionally applied same calculation above.



3.8 Conducted Spurious Emission

3.8.1 Description of Conducted Spurious Emission Measurement

The power of any emission outside of the authorized operating frequency ranges must be lower than the transmitter power (P) by a factor of at least $43 + 10 \log (P)$ dB.

For 5G NR n41:

The power of any emission outside of the authorized operating frequency ranges must be lower than the transmitter power (P) by a factor of at least $55 + 10 \log (P)$ dB.

It is measured by means of a calibrated spectrum analyzer and scanned from 30 MHz up to a frequency including its 10th harmonic.

3.8.2 Test Procedures

1. The testing follows ANSI C63.26 section 5.7
2. The EUT was connected to spectrum analyzer and system simulator via a power divider.
3. The RF output of EUT was connected to the spectrum analyzer by RF cable and attenuator. The path loss was compensated to the results for each measurement.
4. The middle channel for the highest RF power within the transmitting frequency was measured.
5. The conducted spurious emission for the whole frequency range was taken.
6. Make the measurement with the spectrum analyzer's RBW = 1MHz, VBW = 3MHz.
7. Set spectrum analyzer with RMS detector.
8. Taking the record of maximum spurious emission.
9. The RF fundamental frequency should be excluded against the limit line in the operating frequency band.
10. The limit line is derived from $43 + 10\log(P)$ dB below the transmitter power P(Watts)
= $P(W) - [43 + 10\log(P)]$ (dB)
= $[30 + 10\log(P)]$ (dBm) - $[43 + 10\log(P)]$ (dB)
= -13dBm.
11. For 5G NR n41
The limit line is derived from $55 + 10\log(P)$ dB below the transmitter power P(Watts)
= $P(W) - [55 + 10\log(P)]$ (dB)
= $[30 + 10\log(P)]$ (dBm) - $[55 + 10\log(P)]$ (dB)
= -25dBm.



3.9 Frequency Stability

3.9.1 Description of Frequency Stability Measurement

The frequency stability shall be measured by variation of ambient temperature and variation of primary supply voltage to ensure that the fundamental emission stays within the authorized frequency block. The frequency stability of the transmitter shall be maintained within $\pm 0.00025\%$ ($\pm 2.5\text{ppm}$) of the center frequency.

3.9.2 Test Procedures for Temperature Variation

1. The testing follows ANSI C63.26 section 5.6.4
2. The EUT was set up in the thermal chamber and connected with the system simulator.
3. With power OFF, the temperature was decreased to -30°C and the EUT was stabilized before testing. Power was applied and the maximum change in frequency was recorded within one minute.
4. With power OFF, the temperature was raised in 10°C step up to 50°C . The EUT was stabilized at each step for at least half an hour. Power was applied and the maximum frequency change was recorded within one minute.

3.9.3 Test Procedures for Voltage Variation

1. The testing follows ANSI C63.26 section 5.6.5
2. The EUT was placed in a temperature chamber at $20\pm 5^{\circ}\text{C}$ and connected with the system simulator.
3. The power supply voltage to the EUT was varied from 85% to 115% of the nominal value for other than hand carried battery equipment.
4. For hand carried, battery powered equipment, reduce the primary ac or dc supply voltage to the battery operating end point, which shall be specified by the manufacturer.
5. The variation in frequency was measured for the worst case.

4 Radiated Test Items

4.1 Measuring Instruments

See list of measuring instruments of this test report.

4.2 Test Setup

4.2.1 For radiated test from 30MHz to 1GHz

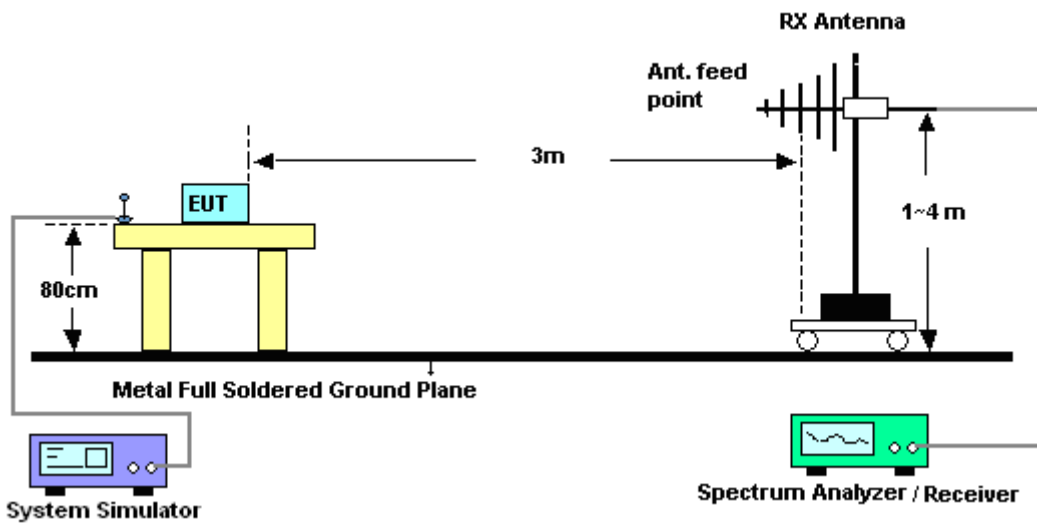

4.2.2 For radiated test above 1GHz

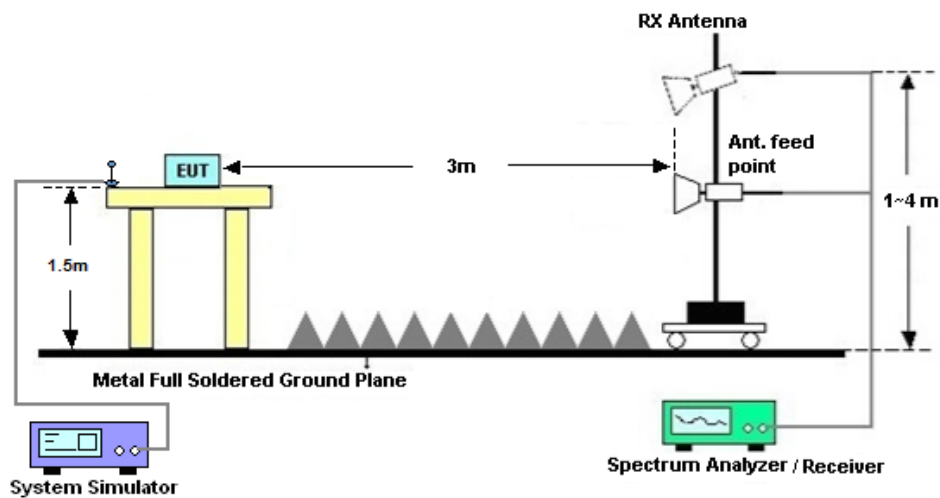

4.3 Test Result of Radiated Test

Please refer to Appendix B.



4.4 Radiated Spurious Emission

4.4.1 Description of Radiated Spurious Emission

The radiated spurious emission was measured by substitution method according to ANSI C63.26. The power of any emission outside of the authorized operating frequency ranges must be attenuated below the transmitter power (P) by a factor of at least $43 + 10 \log (P)$ dB.

For 5G NR n41

The power of any emission outside of the authorized operating frequency ranges must be attenuated below the transmitter power (P) by a factor of at least $55 + 10 \log (P)$ dB.

The spectrum is scanned from 30 MHz up to a frequency including its 10th harmonic.

4.4.2 Test Procedures

1. The testing follows ANSI C63.26 Section 5.5
2. The EUT was placed on a turntable with 0.8 meter height for frequency below 1GHz and 1.5 meter height for frequency above 1GHz respectively above ground.
3. The EUT was set 3 meters from the receiving antenna mounted on the antenna tower.
4. The table was rotated 360 degrees to determine the position of the highest spurious emission.
5. The height of the receiving antenna is varied between 1m to 4m to search the maximum spurious emission for both horizontal and vertical polarizations.
6. During the measurement, the system simulator parameters were set to force the EUT transmitting at maximum output power.
7. Make the measurement with the spectrum analyzer's RBW = 1MHz, VBW = 3MHz, taking the record of maximum spurious emission.
8. A horn antenna was substituted in place of the EUT and was driven by a signal generator.
9. Tune the output power of signal generator to the same emission level with EUT maximum spurious emission.
10. $EIRP (dBm) = S.G. Power - Tx Cable Loss + Tx Antenna Gain$
11. $ERP (dBm) = EIRP - 2.15$
12. The RF fundamental frequency should be excluded against the limit line in the operating frequency band.

The limit line is derived from $43 + 10\log(P)$ dB below the transmitter power P(Watts)
 $= P(W) - [43 + 10\log(P)] (dB)$
 $= [30 + 10\log(P)] (dBm) - [43 + 10\log(P)] (dB)$
 $= -13dBm.$

13. For 5G NR n41:

The limit line is derived from $55 + 10\log(P)$ dB below the transmitter power P(Watts)The limit line is derived from $55 + 10\log(P)$ dB below the transmitter power P(Watts)



5 List of Measuring Equipment

Instrument	Manufacturer	Model No.	Serial No.	Characteristics	Calibration Date	Test Date	Due Date	Remark
Spectrum Analyzer	R&S	FSV40	101040	10Hz~40GHz	Nov. 02, 2019	Jun. 22, 2020~ Jun. 28, 2020	Nov. 01, 2020	Conducted (TH01-KS)
Thermal Chamber	Ten Billion	TTC-B3S	TBN-960502	-40~+150°C	Oct. 28, 2019	Jun. 22, 2020~ Jun. 28, 2020	Oct. 27, 2020	Conducted (TH01-KS)
EXA Spectrum Analyzer	Keysight	N9010A	MY55150244	10Hz-44G,MAX 30dB	Apr. 15, 2020	Jul. 15, 2020	Apr. 14, 2021	Radiation (03CH04-KS)
Bilog Antenna	TeseQ	CBL6111D	49922	30MHz-1GHz	Jun. 08, 2020	Jul. 15, 2020	Jun. 07, 2021	Radiation (03CH04-KS)
Horn Antenna	Schwarzbeck	BBHA9120D	1356	1GHz~18GHz	Apr. 20, 2020	Jul. 15, 2020	Apr. 19, 2021	Radiation (03CH04-KS)
SHF-EHF Horn	Com-power	AH-840	101115	18GHz~40GHz	Nov. 10, 2019	Jul. 15, 2020	Nov. 09, 2020	Radiation (03CH04-KS)
Amplifier	SONOMA	310N	187289	9KHz-1GHz	Aug. 06, 2019	Jul. 15, 2020	Aug. 05, 2020	Radiation (03CH04-KS)
Amplifier	MITEQ	EM18G40G GA	060728	18~40GHz	Jan. 08, 2020	Jul. 15, 2020	Jan. 07, 2021	Radiation (03CH04-KS)
high gain Amplifier	MITEQ	AMF-7D-00 101800-30-1 0P	2025788	1Ghz-18Ghz	Aug. 16, 2019	Jul. 15, 2020	Aug. 15, 2020	Radiation (03CH04-KS)
Amplifier	Keysight	83017A	MY57280106	500MHz~26.5GHz	Oct. 15, 2019	Jul. 15, 2020	Oct. 14, 2020	Radiation (03CH04-KS)
AC Power Source	Chroma	61601	F104090004	N/A	NCR	Jul. 15, 2020	NCR	Radiation (03CH04-KS)
Turn Table	ChamPro	EM 1000-T	060762-T	0~360 degree	NCR	Jul. 15, 2020	NCR	Radiation (03CH04-KS)
Antenna Mast	ChamPro	EM 1000-A	060762-A	1 m~4 m	NCR	Jul. 15, 2020	NCR	Radiation (03CH04-KS)

NCR: No Calibration Required



6 Uncertainty of Evaluation

The measurement uncertainties shown below were calculated in accordance with the requirements of ANSI 63.26-2015. All the measurement uncertainty value were shown with a coverage K=2 to indicate 95% level of confidence. The measurement data show herein meets or exceeds the CISPR measurement uncertainty values specified in CISPR 16-4-2 and can be compared directly to specified limit to determine compliance.

Uncertainty of Radiated Emission Measurement (30 MHz ~ 1000 MHz)

Measuring Uncertainty for a Level of Confidence of 95% (U = 2Uc(y))	3.3dB
---	-------

Uncertainty of Radiated Emission Measurement (1 GHz ~ 18 GHz)

Measuring Uncertainty for a Level of Confidence of 95% (U = 2Uc(y))	2.8dB
---	-------

Uncertainty of Radiated Emission Measurement (18 GHz ~ 40 GHz)

Measuring Uncertainty for a Level of Confidence of 95% (U = 2Uc(y))	2.8dB
---	-------



Appendix A. Test Results of Conducted Test

Conducted Output Power(Average power and EIRP)

5G NR n5 DFT-s-OFDM Power						
BW [MHz]	Modulation	RB Size	RB Offset	Power Low Ch. / Freq.	Power Middle Ch. / Freq.	Power High Ch. / Freq.
Channel				165300	167300	169300
Frequency (MHz)				826.5	836.5	846.5
5	PI/2 BPSK	1	1	24.28	24.24	24.19
5	PI/2 BPSK	1	23	24.18	23.89	23.81
5	PI/2 BPSK	12	6	24.23	24.25	24.17
5	PI/2 BPSK	1	0	23.26	23.72	23.46
5	PI/2 BPSK	1	24	23.61	23.52	23.26
5	PI/2 BPSK	25	0	23.75	23.68	23.49
5	QPSK	1	1	24.22	24.16	23.95
5	QPSK	1	23	23.98	24.07	23.91
5	QPSK	12	6	24.36	24.46	24.07
5	QPSK	1	0	23.27	23.23	23.11
5	QPSK	1	24	23.16	23.06	22.89
5	QPSK	25	0	23.29	23.24	23.06
5	16QAM	1	1	23.58	23.08	23.01
5	16QAM	1	23	23.36	22.77	22.85
5	16QAM	12	6	23.24	23.15	23.02
5	16QAM	1	0	22.16	22.03	21.99
5	16QAM	1	24	21.95	21.75	22.37
5	16QAM	25	0	22.39	22.12	22.08
5	64QAM	1	1	21.81	21.74	21.73
5	64QAM	1	23	21.73	21.63	21.47
5	64QAM	12	6	21.96	21.79	21.51
5	64QAM	1	0	21.75	21.75	21.78
5	64QAM	1	24	21.68	21.61	21.43
5	64QAM	25	0	21.89	21.71	21.57



5	256QAM	1	1	19.41	19.44	19.19
5	256QAM	1	23	19.27	19.19	19.11
5	256QAM	12	6	19.59	19.51	19.44
5	256QAM	1	0	19.47	19.42	19.22
5	256QAM	1	24	19.26	19.08	19.09
5	256QAM	25	0	19.67	19.58	19.56
Channel				165800	167300	168800
Frequency (MHz)				829	836.5	844
10	PI/2 BPSK	1	1	24.33	24.11	24.00
10	PI/2 BPSK	1	50	24.16	24.17	23.84
10	PI/2 BPSK	25	12	24.60	24.36	24.19
10	PI/2 BPSK	1	0	23.68	23.59	23.48
10	PI/2 BPSK	1	51	23.59	23.51	23.24
10	PI/2 BPSK	50	0	23.81	23.76	23.51
10	QPSK	1	1	24.18	24.15	23.98
10	QPSK	1	50	24.17	24.13	23.85
10	QPSK	25	12	24.29	24.27	24.18
10	QPSK	1	0	23.08	23.18	23.01
10	QPSK	1	51	23.03	23.08	22.74
10	QPSK	50	0	23.28	23.23	23.01
10	16QAM	1	1	23.36	22.52	22.29
10	16QAM	1	50	23.37	22.31	22.22
10	16QAM	25	12	23.51	23.33	23.04
10	16QAM	1	0	22.08	22.17	21..99
10	16QAM	1	51	21.94	21.91	21.58
10	16QAM	50	0	22.34	22.27	21.97
10	64QAM	1	1	21.79	21.75	21.71
10	64QAM	1	50	21.79	21.54	21.46
10	64QAM	25	12	21.87	21.75	21.55
10	64QAM	1	0	21.83	21.82	21.34
10	64QAM	1	51	21.81	21.22	21.36
10	64QAM	50	0	21.77	21.69	21.44
10	256QAM	1	1	19.35	19.39	19.32
10	256QAM	1	50	19.31	19.14	19.03
10	256QAM	25	12	19.68	19.65	19.45
10	256QAM	1	0	19.33	19.38	19.22



10	256QAM	1	51	19.17	19.22	19.04
10	256QAM	50	0	19.64	19.71	19.38
Channel				166300	167300	168300
Frequency (MHz)				831.5	836.5	841.5
15	PI/2 BPSK	1	1	24.39	24.29	24.12
15	PI/2 BPSK	1	77	24.14	24.23	23.87
15	PI/2 BPSK	36	18	24.38	24.31	24.06
15	PI/2 BPSK	1	0	23.81	23.82	23.55
15	PI/2 BPSK	1	78	23.64	23.65	23.41
15	PI/2 BPSK	75	0	23.86	23.82	23.62
15	QPSK	1	1	24.28	24.31	24.19
15	QPSK	1	77	24.31	23.91	23.92
15	QPSK	36	18	24.34	24.21	24.06
15	QPSK	1	0	23.54	23.53	23.11
15	QPSK	1	78	23.18	23.05	22.94
15	QPSK	75	0	23.25	23.17	23.14
15	16QAM	1	1	23.44	23.26	23.19
15	16QAM	1	77	23.47	23.22	23.01
15	16QAM	36	18	23.51	23.26	23.14
15	16QAM	1	0	22.12	22.31	22.33
15	16QAM	1	78	21.97	22.01	22.05
15	16QAM	75	0	22.25	22.25	22.06
15	64QAM	1	1	22.12	21.34	21.16
15	64QAM	1	77	22.56	21.53	21.05
15	64QAM	36	18	21.76	21.84	21.57
15	64QAM	1	0	22.21	21.36	21.26
15	64QAM	1	78	22.35	21.11	21.03
15	64QAM	75	0	21.75	21.63	21.58
15	256QAM	1	1	19.43	21.61	19.43
15	256QAM	1	77	19.12	21.27	19.22
15	256QAM	36	18	19.60	21.71	19.53
15	256QAM	1	0	19.42	21.59	19.43
15	256QAM	1	78	19.21	21.32	19.25
15	256QAM	75	0	19.64	21.82	19.59
Channel				166800	167300	167800
Frequency (MHz)				834	836.5	839



20	PI/2 BPSK	1	1	24.69	24.33	24.12
20	PI/2 BPSK	1	104	24.07	24.01	23.98
20	PI/2 BPSK	50	25	24.45	24.32	24.23
20	PI/2 BPSK	1	0	23.89	23.83	23.60
20	PI/2 BPSK	1	105	23.73	23.54	23.34
20	PI/2 BPSK	100	0	23.91	23.85	23.66
20	QPSK	1	1	24.45	24.33	24.23
20	QPSK	1	104	24.25	24.17	23.84
20	QPSK	50	25	24.45	24.45	24.11
20	QPSK	1	0	23.35	23.32	23.12
20	QPSK	1	105	23.19	23.01	22.87
20	QPSK	100	0	23.43	23.25	23.00
20	16QAM	1	1	23.58	23.16	22.97
20	16QAM	1	104	23.27	22.47	22.68
20	16QAM	50	25	23.41	23.27	22.96
20	16QAM	1	0	22.16	22.23	22.18
20	16QAM	1	105	22.01	21.95	21.62
20	16QAM	100	0	22.39	22.23	21.99
20	64QAM	1	1	21.51	21.72	21.49
20	64QAM	1	104	21.26	21.52	21.26
20	64QAM	50	25	21.79	21.81	21.49
20	64QAM	1	0	21.59	21.77	21.53
20	64QAM	1	105	21.44	21.48	21.26
20	64QAM	100	0	21.81	21.71	21.53
20	256QAM	1	1	19.48	19.81	19.17
20	256QAM	1	104	19.28	19.33	18.91
20	256QAM	50	25	19.84	19.85	19.55
20	256QAM	1	0	19.51	19.74	19.24
20	256QAM	1	105	19.08	19.28	18.91
20	256QAM	100	0	19.93	19.81	19.61



ERP (5G NR n5 DFT-s-OFDM)

NR n5 / 5MHz (Average) (GT - LC = -3 dB)							
Channel	Mode	RB		Conducted		ERP	
		Size	Offset	Power (dBm)	Power (Watts)	ERP(dBm)	ERP(W)
Lowest	PI/2 BPSK	1	1	24.28	0.2680	19.13	0.0819
Middle		1	1	24.24	0.2655	19.09	0.0811
Highest		1	1	24.19	0.2625	19.04	0.0802
Lowest	QPSK	12	6	24.36	0.2729	19.21	0.0834
Middle		12	6	24.46	0.2793	19.31	0.0854
Highest		12	6	24.07	0.2553	18.92	0.0780
Lowest	16QAM	1	1	23.58	0.2281	18.43	0.0697
Middle		1	1	23.08	0.2033	17.93	0.0621
Highest		1	1	23.01	0.2000	17.86	0.0611
Lowest	64QAM	12	6	21.96	0.1571	16.81	0.0480
Middle		12	6	21.79	0.1511	16.64	0.0462
Highest		12	6	21.51	0.1416	16.36	0.0433
Lowest	256QAM	25	0	19.67	0.0927	14.52	0.0284
Middle		25	0	19.58	0.0908	14.43	0.0278
Highest		25	0	19.56	0.0904	14.41	0.0277
Limit	ERP < 7W			Result		PASS	

NR n5 / 10MHz (Average) (GT - LC = -3 dB)							
Channel	Mode	RB		Conducted		ERP	
		Size	Offset	Power (dBm)	Power (Watts)	ERP(dBm)	ERP(W)
Lowest	PI/2 BPSK	25	12	24.60	0.2885	19.45	0.0882
Middle		25	12	24.36	0.2729	19.21	0.0834
Highest		25	12	24.19	0.2625	19.04	0.0802
Lowest	QPSK	25	12	24.29	0.2686	19.14	0.0821
Middle		25	12	24.27	0.2674	19.12	0.0817
Highest		25	12	24.18	0.2619	19.03	0.0800
Lowest	16QAM	25	12	23.51	0.2244	18.36	0.0686
Middle		25	12	23.33	0.2153	18.18	0.0658
Highest		25	12	23.04	0.2014	17.89	0.0616
Lowest	64QAM	25	12	21.87	0.1539	16.72	0.0470
Middle		25	12	21.75	0.1497	16.60	0.0458



Highest		25	12	21.55	0.1429	16.40	0.0437
Lowest	256QAM	50	0	19.64	0.0921	14.49	0.0282
Middle		50	0	19.71	0.0936	14.56	0.0286
Highest		50	0	19.38	0.0867	14.23	0.0265
Limit	ERP < 7W			Result		PASS	

NR n5 / 15MHz (Average) (GT - LC = -3 dB)							
Channel	Mode	RB		Conducted		ERP	
		Size	Offset	Power (dBm)	Power (Watts)	ERP(dBm)	ERP(W)
Lowest	PI/2 BPSK	1	1	24.39	0.2748	19.24	0.0840
Middle		1	1	24.29	0.2686	19.14	0.0821
Highest		1	1	24.12	0.2583	18.97	0.0789
Lowest	QPSK	36	18	24.34	0.2717	19.19	0.0830
Middle		36	18	24.21	0.2637	19.06	0.0806
Highest		36	18	24.06	0.2547	18.91	0.0779
Lowest	16QAM	36	18	23.51	0.2244	18.36	0.0686
Middle		36	18	23.26	0.2119	18.11	0.0648
Highest		36	18	23.14	0.2061	17.99	0.0630
Lowest	64QAM	1	77	22.56	0.1804	17.41	0.0551
Middle		1	77	21.53	0.1423	16.38	0.0435
Highest		1	77	21.05	0.1274	15.90	0.0390
Lowest	256QAM	75	0	19.64	0.0921	14.49	0.0282
Middle		75	0	21.82	0.1521	16.67	0.0465
Highest		75	0	19.59	0.0910	14.44	0.0278
Limit	ERP < 7W			Result		PASS	

NR n5 / 20MHz (Average) (GT - LC = -3 dB)							
Channel	Mode	RB		Conducted		ERP	
		Size	Offset	Power (dBm)	Power (Watts)	ERP(dBm)	ERP(W)
Lowest	PI/2 BPSK	1	1	24.69	0.2945	19.54	0.0900
Middle		1	1	24.33	0.2711	19.18	0.0828
Highest		1	1	24.12	0.2583	18.97	0.0789
Lowest	QPSK	1	1	24.45	0.2787	19.30	0.0852
Middle		1	1	24.33	0.2711	19.18	0.0828
Highest		1	1	24.23	0.2649	19.08	0.0810



Lowest	16QAM	1	1	23.58	0.2281	18.43	0.0697
Middle		1	1	23.16	0.2071	18.01	0.0633
Highest		1	1	22.97	0.1982	17.82	0.0606
Lowest	64QAM	50	25	21.79	0.1511	16.64	0.0462
Middle		50	25	21.81	0.1518	16.66	0.0464
Highest		50	25	21.49	0.1410	16.34	0.0431
Lowest	256QAM	100	0	19.93	0.0985	14.78	0.0301
Middle		100	0	19.81	0.0958	14.66	0.0293
Highest		100	0	19.61	0.0915	14.46	0.0280
Limit	ERP < 7W			Result		PASS	



5G NR n41 DFT-s-OFDM Power						
BW [MHz]	Modulation	RB Size	RB Offset	Power Low Ch. / Freq.	Power Middle Ch. / Freq.	Power High Ch. / Freq.
Channel				501204	518598	535998
Frequency (MHz)				2506.02	2592.99	2679.99
20	PI/2 BPSK	1	1	26.21	26.42	25.63
20	PI/2 BPSK	1	49	26.13	26.17	25.88
20	PI/2 BPSK	25	12	26.19	26.22	26.16
20	PI/2 BPSK	1	0	26.00	25.82	25.03
20	PI/2 BPSK	1	50	26.02	26.13	25.82
20	PI/2 BPSK	50	0	25.92	25.96	25.44
20	QPSK	1	1	25.87	25.95	24.54
20	QPSK	1	49	26.02	26.05	25.76
20	QPSK	25	12	25.10	26.31	25.51
20	QPSK	1	0	25.10	24.99	23.49
20	QPSK	1	50	25.08	25.16	24.71
20	QPSK	50	0	25.14	25.53	24.53
20	16QAM	1	1	25.10	25.11	23.62
20	16QAM	1	49	25.13	25.12	24.74
20	16QAM	25	12	25.19	25.56	24.81
20	16QAM	1	0	24.03	24.09	22.56
20	16QAM	1	50	24.51	24.19	23.67
20	16QAM	50	0	24.11	24.23	23.63
20	64QAM	1	1	23.66	23.72	23.60
20	64QAM	1	49	23.71	23.75	24.72
20	64QAM	25	12	23.79	24.23	24.80
20	64QAM	1	0	23.61	23.67	22.54
20	64QAM	1	50	23.95	23.72	23.65
20	64QAM	50	0	23.90	24.13	23.63
20	256QAM	1	1	21.30	23.33	20.45
20	256QAM	1	49	21.46	23.36	21.11
20	256QAM	25	12	21.78	24.25	21.48
20	256QAM	1	0	21.26	23.25	20.40



20	256QAM	1	50	21.35	23.30	21.09
20	256QAM	50	0	21.86	24.15	21.39
Channel				503202	518598	534000
Frequency (MHz)				2516.01	2592.99	2670
40	PI/2 BPSK	1	1	26.33	26.05	26.39
40	PI/2 BPSK	1	104	26.55	26.61	26.19
40	PI/2 BPSK	50	25	26.16	26.54	26.05
40	PI/2 BPSK	1	0	25.93	25.77	26.35
40	PI/2 BPSK	1	105	26.35	26.18	25.81
40	PI/2 BPSK	100	0	26.24	26.19	26.06
40	QPSK	1	1	25.86	25.57	25.90
40	QPSK	1	104	26.37	26.14	25.44
40	QPSK	50	25	26.28	26.29	25.57
40	QPSK	1	0	24.84	24.50	24.85
40	QPSK	1	105	25.37	25.13	24.39
40	QPSK	100	0	25.57	25.37	24.77
40	16QAM	1	1	24.55	24.72	24.95
40	16QAM	1	104	25.36	25.22	24.33
40	16QAM	50	25	25.96	25.78	24.98
40	16QAM	1	0	23.50	23.65	23.96
40	16QAM	1	105	24.36	24.21	23.34
40	16QAM	100	0	24.70	24.53	23.84
40	64QAM	1	1	23.14	23.27	23.23
40	64QAM	1	104	23.91	23.68	22.55
40	64QAM	50	25	24.11	24.08	23.27
40	64QAM	1	0	23.11	23.23	23.23
40	64QAM	1	105	23.89	23.67	22.54
40	64QAM	100	0	24.07	23.87	23.19
40	256QAM	1	1	21.27	21.14	21.79
40	256QAM	1	104	21.84	21.65	21.02
40	256QAM	50	25	21.93	22.35	21.91
40	256QAM	1	0	21.26	21.09	21.81
40	256QAM	1	105	21.81	21.65	21.01
40	256QAM	100	0	22.01	22.15	21.89
Channel				504204	518598	532998
Frequency (MHz)				2521.02	2592.99	2664.99



50	PI/2 BPSK	1	1	25.81	25.98	26.24
50	PI/2 BPSK	1	131	26.13	26.27	26.15
50	PI/2 BPSK	64	32	26.37	26.42	26.23
50	PI/2 BPSK	1	0	25.64	25.44	26.17
50	PI/2 BPSK	1	132	26.01	26.22	25.75
50	PI/2 BPSK	128	0	25.98	26.08	25.95
50	QPSK	1	1	25.92	25.70	26.20
50	QPSK	1	131	26.12	26.19	26.09
50	QPSK	64	32	26.11	26.20	26.21
50	QPSK	1	0	25.08	24.98	25.45
50	QPSK	1	132	25.14	25.51	25.12
50	QPSK	128	0	25.25	25.50	25.12
50	16QAM	1	1	25.59	25.03	25.59
50	16QAM	1	131	25.57	24.66	24.99
50	16QAM	64	32	25.55	25.49	25.19
50	16QAM	1	0	24.20	24.11	24.33
50	16QAM	1	132	24.36	24.67	23.88
50	16QAM	128	0	24.39	24.41	24.34
50	64QAM	1	1	23.62	23.48	23.82
50	64QAM	1	131	23.55	24.17	23.42
50	64QAM	64	32	24.04	23.91	23.57
50	64QAM	1	0	23.39	23.45	23.88
50	64QAM	1	132	23.57	14.26	23.42
50	64QAM	128	0	23.71	23.85	23.69
50	256QAM	1	1	21.54	21.22	22.04
50	256QAM	1	131	21.60	21.75	21.30
50	256QAM	64	32	21.64	22.00	21.96
50	256QAM	1	0	21.54	21.41	22.12
50	256QAM	1	132	21.66	21.97	21.28
50	256QAM	128	0	21.98	21.23	21.69
Channel				505200	518598	531996
Frequency (MHz)				2526	2592.99	2659.98
60	PI/2 BPSK	1	1	25.86	25.75	26.30
60	PI/2 BPSK	1	160	25.92	26.29	25.94
60	PI/2 BPSK	81	40	26.42	26.14	25.28
60	PI/2 BPSK	1	0	25.52	25.25	25.89



60	PI/2 BPSK	1	161	26.11	26.04	25.44
60	PI/2 BPSK	162	0	25.79	25.71	26.02
60	QPSK	1	1	25.79	25.47	26.35
60	QPSK	1	160	25.76	26.15	25.90
60	QPSK	81	40	26.43	26.11	26.15
60	QPSK	1	0	24.90	24.65	25.39
60	QPSK	1	161	24.70	25.30	24.80
60	QPSK	162	0	25.23	25.28	25.32
60	16QAM	1	1	24.93	24.76	25.55
60	16QAM	1	160	24.81	25.59	24.89
60	16QAM	81	40	25.56	25.23	25.44
60	16QAM	1	0	23.83	23.61	24.58
60	16QAM	1	161	23.77	24.47	23.66
60	16QAM	162	0	24.71	24.12	24.26
60	64QAM	1	1	23.24	22.97	23.98
60	64QAM	1	160	23.06	23.74	23.08
60	64QAM	81	40	23.91	23.58	23.65
60	64QAM	1	0	23.19	22.95	24.14
60	64QAM	1	161	23.04	23.76	23.08
60	64QAM	162	0	23.74	23.58	23.96
60	256QAM	1	1	21.47	20.92	21.77
60	256QAM	1	160	21.28	21.69	20.91
60	256QAM	81	40	21.92	21.94	22.01
60	256QAM	1	0	21.19	21.09	21.75
60	256QAM	1	161	21.26	21.70	20.89
60	256QAM	162	0	21.91	21.96	22.02
Channel				507204	518598	529998
Frequency (MHz)				2536.02	2592.99	2649.99
80	PI/2 BPSK	1	1	26.25	26.31	26.78
80	PI/2 BPSK	1	215	25.85	26.12	26.26
80	PI/2 BPSK	108	54	26.11	26.01	26.63
80	PI/2 BPSK	1	0	25.55	25.44	25.97
80	PI/2 BPSK	1	216	25.18	26.12	25.73
80	PI/2 BPSK	216	0	25.98	25.72	26.01
80	QPSK	1	1	25.77	25.59	25.89
80	QPSK	1	215	24.69	26.12	25.77



80	QPSK	108	54	26.10	26.00	26.24
80	QPSK	1	0	24.66	24.61	24.73
80	QPSK	1	216	23.55	25.33	24.63
80	QPSK	216	0	25.31	25.31	25.64
80	16QAM	1	1	24.87	24.50	23.55
80	16QAM	1	215	24.13	25.31	24.79
80	16QAM	108	54	25.22	25.24	25.55
80	16QAM	1	0	23.59	23.48	23.72
80	16QAM	1	216	22.87	24.21	23.52
80	16QAM	216	0	23.58	24.15	24.46
80	64QAM	1	1	22.89	23.31	23.36
80	64QAM	1	215	21.98	23.99	22.94
80	64QAM	108	54	24.00	23.62	23.72
80	64QAM	1	0	22.50	23.23	23.28
80	64QAM	1	216	21.91	23.91	22.92
80	64QAM	216	0	23.76	23.64	23.97
80	256QAM	1	1	21.39	21.11	21.38
80	256QAM	1	215	20.28	21.66	20.63
80	256QAM	108	54	21.71	21.98	22.01
80	256QAM	1	0	21.33	21.15	21.38
80	256QAM	1	216	20.22	21.63	20.62
80	256QAM	216	0	21.61	22.03	21.89
Channel				508200	518598	528996
Frequency (MHz)				2541	2592.99	2644.98
90	PI/2 BPSK	1	1	25.37	25.48	25.61
90	PI/2 BPSK	1	243	25.61	25.62	25.76
90	PI/2 BPSK	120	60	25.81	25.47	25.54
90	PI/2 BPSK	1	0	21.78	23.43	23.45
90	PI/2 BPSK	1	244	22.15	23.42	23.66
90	PI/2 BPSK	240	0	24.83	23.65	23.47
90	QPSK	1	1	25.33	25.43	25.14
90	QPSK	1	243	24.51	25.66	25.42
90	QPSK	120	60	25.57	25.71	25.56
90	QPSK	1	0	21.75	23.06	22.89
90	QPSK	1	244	22.41	22.85	23.03
90	QPSK	240	0	24.01	23.15	23.05



90	16QAM	1	1	23.94	23.32	23.02
90	16QAM	1	243	23.42	23.02	22.91
90	16QAM	120	60	24.85	23.39	23.02
90	16QAM	1	0	21.79	22.01	21.83
90	16QAM	1	244	22.28	22.18	21.81
90	16QAM	240	0	23.16	22.15	21.99
90	64QAM	1	1	22.61	21.53	21.66
90	64QAM	1	243	22.23	21.56	21.87
90	64QAM	120	60	23.25	21.65	21.46
90	64QAM	1	0	22.11	21.52	21.58
90	64QAM	1	244	22.19	21.67	21.59
90	64QAM	240	0	22.51	21.78	21.46
90	256QAM	1	1	20.55	19.37	19.44
90	256QAM	1	243	20.12	19.19	19.45
90	256QAM	120	60	21.22	19.89	19.51
90	256QAM	1	0	20.65	19.12	19.41
90	256QAM	1	244	20.01	19.28	19.34
90	256QAM	240	0	21.14	19.81	19.75
Channel				509202	518598	528000
Frequency (MHz)				2546.01	2592.99	2640
100	PI/2 BPSK	1	1	25.51	25.48	25.91
100	PI/2 BPSK	1	271	25.32	25.62	25.71
100	PI/2 BPSK	135	67	25.71	25.52	25.62
100	PI/2 BPSK	1	0	21.75	23.36	23.49
100	PI/2 BPSK	1	272	22.02	23.34	23.37
100	PI/2 BPSK	270	0	24.58	23.80	23.65
100	QPSK	1	1	25.43	25.53	25.01
100	QPSK	1	271	24.10	25.66	25.42
100	QPSK	135	67	25.61	25.45	25.47
100	QPSK	1	0	21.71	22.83	23.02
100	QPSK	1	272	22.25	22.76	22.85
100	QPSK	270	0	24.16	23.34	23.06
100	16QAM	1	1	24.33	23.18	23.51
100	16QAM	1	271	23.04	22.78	23.16
100	16QAM	135	67	24.52	23.02	22.95
100	16QAM	1	0	21.97	21.87	22.14



100	16QAM	1	272	22.08	21.69	21.68
100	16QAM	270	0	23.37	22.28	22.29
100	64QAM	1	1	22.49	21.58	22.24
100	64QAM	1	271	21.82	21.53	21.47
100	64QAM	135	67	23.19	21.68	21.76
100	64QAM	1	0	21.44	21.34	21.51
100	64QAM	1	272	21.66	21.21	21.59
100	64QAM	270	0	22.67	21.74	21.65
100	256QAM	1	1	20.67	19.29	19.45
100	256QAM	1	271	19.82	19.32	19.45
100	256QAM	135	67	21.11	19.68	19.68
100	256QAM	1	0	20.22	19.21	19.49
100	256QAM	1	272	19.67	19.22	19.17
100	256QAM	270	0	21.06	19.78	19.71



EIRP (5G NR n41 DFT-s-OFDM)

NR n41 / 20MHz (Average) (GT - LC = -3 dB)							
Channel	Mode	RB		Conducted		EIRP	
		Size	Offset	Power (dBm)	Power (Watts)	EIRP(dBm)	EIRP(W)
Lowest	PI/2 BPSK	1	1	26.21	0.4179	23.21	0.2095
Middle		1	1	26.42	0.4386	23.42	0.2198
Highest		1	1	25.63	0.3656	22.63	0.1833
Lowest	QPSK	25	12	25.10	0.3236	22.10	0.1622
Middle		25	12	26.31	0.4276	23.31	0.2143
Highest		25	12	25.51	0.3557	22.51	0.1783
Lowest	16QAM	25	12	25.19	0.3304	22.19	0.1656
Middle		25	12	25.56	0.3598	22.56	0.1804
Highest		25	12	24.81	0.3027	21.81	0.1518
Lowest	64QAM	25	12	23.79	0.2394	20.79	0.1200
Middle		25	12	24.23	0.2649	21.23	0.1328
Highest		25	12	24.80	0.3020	21.80	0.1514
Lowest	256QAM	25	12	21.78	0.1507	18.78	0.0756
Middle		25	12	24.25	0.2661	21.25	0.1334
Highest		25	12	21.48	0.1407	18.48	0.0705
Limit	EIRP < 2W			Result		PASS	

NR n41 / 40MHz (Average) (GT - LC = -3 dB)							
Channel	Mode	RB		Conducted		EIRP	
		Size	Offset	Power (dBm)	Power (Watts)	EIRP(dBm)	EIRP(W)
Lowest	PI/2 BPSK	1	104	26.55	0.4519	23.55	0.2265
Middle		1	104	26.61	0.4582	23.61	0.2297
Highest		1	104	26.19	0.4160	23.19	0.2085
Lowest	QPSK	1	104	26.37	0.4336	23.37	0.2173
Middle		1	104	26.14	0.4112	23.14	0.2061
Highest		1	104	25.44	0.3500	22.44	0.1754
Lowest	16QAM	50	25	25.96	0.3945	22.96	0.1977
Middle		50	25	25.78	0.3785	22.78	0.1897
Highest		50	25	24.98	0.3148	21.98	0.1578
Lowest	64QAM	50	25	24.11	0.2577	21.11	0.1292
Middle		50	25	24.08	0.2559	21.08	0.1283



Highest		50	25	23.27	0.2124	20.27	0.1065
Lowest	256QAM	50	25	21.93	0.1560	18.93	0.0782
Middle		50	25	22.35	0.1718	19.35	0.0861
Highest		50	25	21.91	0.1553	18.91	0.0779
Limit	EIRP < 2W			Result		PASS	

NR n41 / 50MHz (Average) (GT - LC = -3 dB)							
Channel	Mode	RB		Conducted		EIRP	
		Size	Offset	Power (dBm)	Power (Watts)	EIRP(dBm)	EIRP(W)
Lowest	PI/2 BPSK	64	32	26.37	0.4336	23.37	0.2173
Middle		64	32	26.42	0.4386	23.42	0.2198
Highest		64	32	26.23	0.4198	23.23	0.2104
Lowest	QPSK	64	32	26.11	0.4084	23.11	0.2047
Middle		64	32	26.20	0.4169	23.20	0.2090
Highest		64	32	26.21	0.4179	23.21	0.2095
Lowest	16QAM	1	1	25.59	0.3623	22.59	0.1816
Middle		1	1	25.03	0.3185	22.03	0.1596
Highest		1	1	25.59	0.3623	22.59	0.1816
Lowest	64QAM	1	131	23.55	0.2265	20.55	0.1136
Middle		1	131	24.17	0.2613	21.17	0.1310
Highest		1	131	23.42	0.2198	20.42	0.1102
Lowest	256QAM	1	0	21.54	0.1426	18.54	0.0715
Middle		1	0	21.41	0.1384	18.41	0.0694
Highest		1	0	22.12	0.1630	19.12	0.0817
Limit	EIRP < 2W			Result		PASS	

NR n41 / 80MHz (Average) (GT - LC = -3 dB)							
Channel	Mode	RB		Conducted		EIRP	
		Size	Offset	Power (dBm)	Power (Watts)	EIRP(dBm)	EIRP(W)
Lowest	PI/2 BPSK	1	1	26.25	0.4217	23.25	0.2114
Middle		1	1	26.31	0.4276	23.31	0.2143
Highest		1	1	26.78	0.4765	23.78	0.2388
Lowest	QPSK	108	54	26.10	0.4074	23.10	0.2042
Middle		108	54	26.00	0.3982	23.00	0.1996
Highest		108	54	26.24	0.4208	23.24	0.2109
Lowest	16QAM	108	54	25.22	0.3327	22.22	0.1668



Middle		108	54	25.24	0.3342	22.24	0.1675
Highest		108	54	25.55	0.3590	22.55	0.1799
Lowest	64QAM	108	54	24.00	0.2512	21.00	0.1259
Middle		108	54	23.62	0.2302	20.62	0.1154
Highest		108	54	23.72	0.2356	20.72	0.1181
Lowest	256QAM	216	0	21.61	0.1449	18.61	0.0727
Middle		216	0	22.03	0.1596	19.03	0.0800
Highest		216	0	21.89	0.1546	18.89	0.0775
Limit	EIRP < 2W			Result		PASS	

NR n41 / 90MHz (Average) (GT - LC = -3 dB)							
Channel	Mode	RB		Conducted		EIRP	
		Size	Offset	Power (dBm)	Power (Watts)	EIRP(dBm)	EIRP(W)
Lowest	PI/2 BPSK	120	60	25.81	0.3811	22.81	0.1910
Middle		120	60	25.47	0.3524	22.47	0.1767
Highest		120	60	25.54	0.3581	22.54	0.1795
Lowest	QPSK	120	60	25.57	0.3606	22.57	0.1808
Middle		120	60	25.71	0.3724	22.71	0.1867
Highest		120	60	25.56	0.3598	22.56	0.1804
Lowest	16QAM	120	60	24.85	0.3055	21.85	0.1532
Middle		120	60	23.39	0.2183	20.39	0.1094
Highest		120	60	23.02	0.2005	20.02	0.1005
Lowest	64QAM	120	60	23.25	0.2114	20.25	0.1060
Middle		120	60	21.65	0.1463	18.65	0.0733
Highest		120	60	21.46	0.1400	18.46	0.0702
Lowest	256QAM	120	60	21.22	0.1325	18.22	0.0664
Middle		120	60	19.89	0.0975	16.89	0.0489
Highest		120	60	19.51	0.0894	16.51	0.0448
Limit	EIRP < 2W			Result		PASS	

NR n41 / 100MHz (Average) (GT - LC = -3 dB)							
Channel	Mode	RB		Conducted		EIRP	
		Size	Offset	Power (dBm)	Power (Watts)	EIRP(dBm)	EIRP(W)
Lowest	PI/2 BPSK	1	1	25.51	0.3557	22.51	0.1783
Middle		1	1	25.48	0.3532	22.48	0.1771
Highest		1	1	25.91	0.3900	22.91	0.1955



Lowest	QPSK	1	271	24.10	0.2571	21.10	0.1289
Middle		1	271	25.66	0.3682	22.66	0.1846
Highest		1	271	25.42	0.3484	22.42	0.1746
Lowest	16QAM	135	67	24.52	0.2832	21.52	0.1420
Middle		135	67	23.02	0.2005	20.02	0.1005
Highest		135	67	22.95	0.1973	19.95	0.0989
Lowest	64QAM	135	67	23.19	0.2085	20.19	0.1045
Middle		135	67	21.68	0.1473	18.68	0.0738
Highest		135	67	21.76	0.1500	18.76	0.0752
Lowest	256QAM	135	67	21.11	0.1292	18.11	0.0648
Middle		135	67	19.68	0.0929	16.68	0.0466
Highest		135	67	19.68	0.0929	16.68	0.0466
Limit	EIRP < 2W			Result		PASS	

5G NR
n2-
5MHz

Channel	TestItem	MeasuredValue	EIRP power (dbm)	EIRP power (W)
370500	15KHZ 370500 DFT-s-OFDM PI/2 BPSK Inner 1RB Right	22.93	20.93	0.1239
370500	15KHZ 370500 DFT-s-OFDM PI/2 BPSK Inner 1RB Left	23	21.00	0.1259
370500	15KHZ 370500 DFT-s-OFDM PI/2 BPSK Inner Full	22.96	20.96	0.1247
370500	15KHZ 370500 DFT-s-OFDM QPSK Inner 1RB Right	22.93	20.93	0.1239
370500	15KHZ 370500 DFT-s-OFDM QPSK Inner 1RB Left	22.93	20.93	0.1239
370500	15KHZ 370500 DFT-s-OFDM QPSK Inner Full	22.97	20.97	0.1250
370500	15KHZ 370500 DFT-s-OFDM PI/2 BPSK Outer Full	22.67	20.67	0.1167
370500	15KHZ 370500 DFT-s-OFDM QPSK Outer Full	22.1	20.10	0.1023
370500	15KHZ 370500 DFT-s-OFDM 16QAM Inner Full	22.08	20.08	0.1019
370500	15KHZ 370500 DFT-s-OFDM 16QAM Edge 1RB Left	21.04	19.04	0.0802
370500	15KHZ 370500 DFT-s-OFDM 16QAM Edge 1RB Right	21.18	19.18	0.0828
370500	15KHZ 370500 DFT-s-OFDM 16QAM Outer Full	21.19	19.19	0.0830
370500	15KHZ 370500 DFT-s-OFDM 64QAM Edge 1RB Left	20.33	18.33	0.0681
370500	15KHZ 370500 DFT-s-OFDM 64QAM Edge 1RB Right	20.46	18.46	0.0701
370500	15KHZ 370500 DFT-s-OFDM 64QAM Outer Full	20.7	18.70	0.0741
370500	15KHZ 370500 DFT-s-OFDM 256QAM Edge 1RB Left	17.92	15.92	0.0391
370500	15KHZ 370500 DFT-s-OFDM 256QAM Edge 1RB Right	18	16.00	0.0398
370500	15KHZ 370500 DFT-s-OFDM 256QAM Outer Full	18.61	16.61	0.0458
370500	15KHZ 370500 CP-OFDM QPSK Inner Full	21.56	19.56	0.0904
370500	15KHZ 370500 CP-OFDM QPSK Edge 1RB Left	20.11	18.11	0.0647
370500	15KHZ 370500 CP-OFDM QPSK Edge 1RB Right	20.21	18.21	0.0662
370500	15KHZ 370500 CP-OFDM QPSK Outer Full	19.92	17.92	0.0619
370500	15KHZ 370500 CP-OFDM 16QAM Inner Full	20.73	18.73	0.0746
370500	15KHZ 370500 CP-OFDM 16QAM Edge 1RB Left	20.25	18.25	0.0668
370500	15KHZ 370500 CP-OFDM 16QAM Edge 1RB Right	20.33	18.33	0.0681
370500	15KHZ 370500 CP-OFDM 16QAM Outer Full	20.22	18.22	0.0664
370500	15KHZ 370500 CP-OFDM 64QAM Edge 1RB Left	19.32	17.32	0.0540
370500	15KHZ 370500 CP-OFDM 64QAM Edge 1RB Right	19.41	17.41	0.0551
370500	15KHZ 370500 CP-OFDM 64QAM Outer Full	19.58	17.58	0.0573
370500	15KHZ 370500 CP-OFDM 256QAM Edge 1RB Left	15.95	13.95	0.0248
370500	15KHZ 370500 CP-OFDM 256QAM Edge 1RB Right	16.01	14.01	0.0252
370500	15KHZ 370500 CP-OFDM 256QAM Outer Full	16.55	14.55	0.0285
376000	15KHZ 376000 DFT-s-OFDM PI/2 BPSK Inner 1RB Right	23.15	21.15	0.1303
376000	15KHZ 376000 DFT-s-OFDM PI/2 BPSK Inner 1RB Left	23.15	21.15	0.1303
376000	15KHZ 376000 DFT-s-OFDM PI/2 BPSK Inner Full	23.17	21.17	0.1309
376000	15KHZ 376000 DFT-s-OFDM QPSK Inner 1RB Right	23.29	21.29	0.1346
376000	15KHZ 376000 DFT-s-OFDM QPSK Inner 1RB Left	23.1	21.10	0.1288
376000	15KHZ 376000 DFT-s-OFDM QPSK Inner Full	23.11	21.11	0.1291
376000	15KHZ 376000 DFT-s-OFDM PI/2 BPSK Outer Full	22.84	20.84	0.1213
376000	15KHZ 376000 DFT-s-OFDM QPSK Outer Full	22.32	20.32	0.1076
376000	15KHZ 376000 DFT-s-OFDM 16QAM Inner Full	22.33	20.33	0.1079
376000	15KHZ 376000 DFT-s-OFDM 16QAM Edge 1RB Left	21.35	19.35	0.0861
376000	15KHZ 376000 DFT-s-OFDM 16QAM Edge 1RB Right	21.42	19.42	0.0875
376000	15KHZ 376000 DFT-s-OFDM 16QAM Outer Full	21.43	19.43	0.0877
376000	15KHZ 376000 DFT-s-OFDM 64QAM Edge 1RB Left	20.68	18.68	0.0738
376000	15KHZ 376000 DFT-s-OFDM 64QAM Edge 1RB Right	20.66	18.66	0.0735
376000	15KHZ 376000 DFT-s-OFDM 64QAM Outer Full	20.86	18.86	0.0769
376000	15KHZ 376000 DFT-s-OFDM 256QAM Edge 1RB Left	18.28	16.28	0.0425
376000	15KHZ 376000 DFT-s-OFDM 256QAM Edge 1RB Right	18.32	16.32	0.0429
376000	15KHZ 376000 DFT-s-OFDM 256QAM Outer Full	18.88	16.88	0.0488
376000	15KHZ 376000 CP-OFDM QPSK Inner Full	21.39	19.39	0.0869
376000	15KHZ 376000 CP-OFDM QPSK Edge 1RB Left	20.58	18.58	0.0721
376000	15KHZ 376000 CP-OFDM QPSK Edge 1RB Right	20.62	18.62	0.0728
376000	15KHZ 376000 CP-OFDM QPSK Outer Full	20.33	18.33	0.0681
376000	15KHZ 376000 CP-OFDM 16QAM Inner Full	21.29	19.29	0.0849
376000	15KHZ 376000 CP-OFDM 16QAM Edge 1RB Left	20.41	18.41	0.0693
376000	15KHZ 376000 CP-OFDM 16QAM Edge 1RB Right	20.48	18.48	0.0705
376000	15KHZ 376000 CP-OFDM 16QAM Outer Full	20.43	18.43	0.0697
376000	15KHZ 376000 CP-OFDM 64QAM Edge 1RB Left	19.57	17.57	0.0571
376000	15KHZ 376000 CP-OFDM 64QAM Edge 1RB Right	19.61	17.61	0.0577
376000	15KHZ 376000 CP-OFDM 64QAM Outer Full	19.88	17.88	0.0614
376000	15KHZ 376000 CP-OFDM 256QAM Edge 1RB Left	16.2	14.20	0.0263
376000	15KHZ 376000 CP-OFDM 256QAM Edge 1RB Right	16.2	14.20	0.0263
376000	15KHZ 376000 CP-OFDM 256QAM Outer Full	16.81	14.81	0.0303
381500	15KHZ 381500 DFT-s-OFDM PI/2 BPSK Inner 1RB Right	23	21.00	0.1259
381500	15KHZ 381500 DFT-s-OFDM PI/2 BPSK Inner 1RB Left	23.17	21.17	0.1309
381500	15KHZ 381500 DFT-s-OFDM PI/2 BPSK Inner Full	23.12	21.12	0.1294
381500	15KHZ 381500 DFT-s-OFDM QPSK Inner 1RB Right	23.07	21.07	0.1279
381500	15KHZ 381500 DFT-s-OFDM QPSK Inner 1RB Left	22.84	20.84	0.1213
381500	15KHZ 381500 DFT-s-OFDM QPSK Inner Full	23.07	21.07	0.1279
381500	15KHZ 381500 DFT-s-OFDM PI/2 BPSK Outer Full	22.77	20.77	0.1194
381500	15KHZ 381500 DFT-s-OFDM QPSK Outer Full	22.23	20.23	0.1054
381500	15KHZ 381500 DFT-s-OFDM 16QAM Inner Full	22.26	20.26	0.1062
381500	15KHZ 381500 DFT-s-OFDM 16QAM Edge 1RB Left	21.26	19.26	0.0843
381500	15KHZ 381500 DFT-s-OFDM 16QAM Edge 1RB Right	21.24	19.24	0.0839
381500	15KHZ 381500 DFT-s-OFDM 16QAM Outer Full	21.28	19.28	0.0847
381500	15KHZ 381500 DFT-s-OFDM 64QAM Edge 1RB Left	20.53	18.53	0.0713
381500	15KHZ 381500 DFT-s-OFDM 64QAM Edge 1RB Right	20.48	18.48	0.0705
381500	15KHZ 381500 DFT-s-OFDM 64QAM Outer Full	20.79	18.79	0.0757
381500	15KHZ 381500 DFT-s-OFDM 256QAM Edge 1RB Left	18.17	16.17	0.0414
381500	15KHZ 381500 DFT-s-OFDM 256QAM Edge 1RB Right	18.17	16.17	0.0414
381500	15KHZ 381500 DFT-s-OFDM 256QAM Outer Full	18.7	16.70	0.0468
381500	15KHZ 381500 CP-OFDM QPSK Inner Full	21.69	19.69	0.0931
381500	15KHZ 381500 CP-OFDM QPSK Edge 1RB Left	20.29	18.29	0.0675
381500	15KHZ 381500 CP-OFDM QPSK Edge 1RB Right	20.38	18.38	0.0689
381500	15KHZ 381500 CP-OFDM QPSK Outer Full	20.21	18.21	0.0662
381500	15KHZ 381500 CP-OFDM 16QAM Inner Full	21.17	19.17	0.0826
381500	15KHZ 381500 CP-OFDM 16QAM Edge 1RB Left	20.35	18.35	0.0684
381500	15KHZ 381500 CP-OFDM 16QAM Edge 1RB Right	20.25	18.25	0.0668
381500	15KHZ 381500 CP-OFDM 16QAM Outer Full	20.37	18.37	0.0687
381500	15KHZ 381500 CP-OFDM 64QAM Edge 1RB Left	19.42	17.42	0.0552
381500	15KHZ 381500 CP-OFDM 64QAM Edge 1RB Right	19.49	17.49	0.0561
381500	15KHZ 381500 CP-OFDM 64QAM Outer Full	19.71	17.71	0.0590
381500	15KHZ 381500 CP-OFDM 256QAM Edge 1RB Left	16.08	14.08	0.0256
381500	15KHZ 381500 CP-OFDM 256QAM Edge 1RB Right	16.06	14.06	0.0255
381500	15KHZ 381500 CP-OFDM 256QAM Outer Full	16.63	14.63	0.0290

5G NR n2- 10MHz	Channel	TestItem	MeasuredValue	EIRP POWER(dbm)	EIRP power(W)
		371000	15KHZ 371000 DFT-s-OFDM PI/2 BPSK Inner 1RB Right	23.09	21.09
	371000	15KHZ 371000 DFT-s-OFDM PI/2 BPSK Inner 1RB Left	23.07	21.07	0.1279
	371000	15KHZ 371000 DFT-s-OFDM PI/2 BPSK Inner Full	23.01	21.01	0.1262
	371000	15KHZ 371000 DFT-s-OFDM QPSK Inner 1RB Right	23.02	21.02	0.1265
	371000	15KHZ 371000 DFT-s-OFDM QPSK Inner 1RB Left	22.99	20.99	0.1256
	371000	15KHZ 371000 DFT-s-OFDM QPSK Inner Full	23.05	21.05	0.1274
	371000	15KHZ 371000 DFT-s-OFDM PI/2 BPSK Outer Full	22.79	20.79	0.1199
	371000	15KHZ 371000 DFT-s-OFDM QPSK Outer Full	22.19	20.19	0.1045
	371000	15KHZ 371000 DFT-s-OFDM 16QAM Inner Full	22.35	20.35	0.1084
	371000	15KHZ 371000 DFT-s-OFDM 16QAM Edge 1RB Left	21.2	19.2	0.0832
	371000	15KHZ 371000 DFT-s-OFDM 16QAM Edge 1RB Right	21.2	19.2	0.0832
	371000	15KHZ 371000 DFT-s-OFDM 16QAM Outer Full	21.29	19.29	0.0849
	371000	15KHZ 371000 DFT-s-OFDM 64QAM Edge 1RB Left	20.56	18.56	0.0718
	371000	15KHZ 371000 DFT-s-OFDM 64QAM Edge 1RB Right	20.45	18.45	0.0700
	371000	15KHZ 371000 DFT-s-OFDM 64QAM Outer Full	20.71	18.71	0.0743
	371000	15KHZ 371000 DFT-s-OFDM 256QAM Edge 1RB Left	18.2	16.2	0.0417
	371000	15KHZ 371000 DFT-s-OFDM 256QAM Edge 1RB Right	18.02	16.02	0.0400
	371000	15KHZ 371000 DFT-s-OFDM 256QAM Outer Full	18.64	16.64	0.0461
	371000	15KHZ 371000 CP-OFDM QPSK Inner Full	21.42	19.42	0.0875
	371000	15KHZ 371000 CP-OFDM QPSK Edge 1RB Left	20.42	18.42	0.0695
	371000	15KHZ 371000 CP-OFDM QPSK Edge 1RB Right	20.45	18.45	0.0700
	371000	15KHZ 371000 CP-OFDM QPSK Outer Full	20.16	18.16	0.0655
	371000	15KHZ 371000 CP-OFDM 16QAM Inner Full	21.24	19.24	0.0839
	371000	15KHZ 371000 CP-OFDM 16QAM Edge 1RB Left	20.25	18.25	0.0668
	371000	15KHZ 371000 CP-OFDM 16QAM Edge 1RB Right	20.28	18.28	0.0673
	371000	15KHZ 371000 CP-OFDM 16QAM Outer Full	20.19	18.19	0.0659
	371000	15KHZ 371000 CP-OFDM 64QAM Edge 1RB Left	19.43	17.43	0.0553
	371000	15KHZ 371000 CP-OFDM 64QAM Edge 1RB Right	19.33	17.33	0.0541
	371000	15KHZ 371000 CP-OFDM 64QAM Outer Full	19.71	17.71	0.0590
	371000	15KHZ 371000 CP-OFDM 256QAM Edge 1RB Left	15.95	13.95	0.0248
	371000	15KHZ 371000 CP-OFDM 256QAM Edge 1RB Right	15.91	13.91	0.0246
	371000	15KHZ 371000 CP-OFDM 256QAM Outer Full	16.68	14.68	0.0294
	376000	15KHZ 376000 DFT-s-OFDM PI/2 BPSK Inner 1RB Right	23.14	21.14	0.1300
	376000	15KHZ 376000 DFT-s-OFDM PI/2 BPSK Inner 1RB Left	23.12	21.12	0.1294
	376000	15KHZ 376000 DFT-s-OFDM PI/2 BPSK Inner Full	23.24	21.24	0.1330
	376000	15KHZ 376000 DFT-s-OFDM QPSK Inner 1RB Right	23.19	21.19	0.1315
	376000	15KHZ 376000 DFT-s-OFDM QPSK Inner 1RB Left	23.21	21.21	0.1321
	376000	15KHZ 376000 DFT-s-OFDM QPSK Inner Full	23.29	21.29	0.1346
	376000	15KHZ 376000 DFT-s-OFDM PI/2 BPSK Outer Full	22.9	20.9	0.1230
	376000	15KHZ 376000 DFT-s-OFDM QPSK Outer Full	22.35	20.35	0.1084
	376000	15KHZ 376000 DFT-s-OFDM 16QAM Inner Full	22.42	20.42	0.1102
	376000	15KHZ 376000 DFT-s-OFDM 16QAM Edge 1RB Left	21.32	19.32	0.0855
	376000	15KHZ 376000 DFT-s-OFDM 16QAM Edge 1RB Right	21.3	19.3	0.0851
	376000	15KHZ 376000 DFT-s-OFDM 16QAM Outer Full	21.47	19.47	0.0885
	376000	15KHZ 376000 DFT-s-OFDM 64QAM Edge 1RB Left	20.68	18.68	0.0738
	376000	15KHZ 376000 DFT-s-OFDM 64QAM Edge 1RB Right	20.67	18.67	0.0736
	376000	15KHZ 376000 DFT-s-OFDM 64QAM Outer Full	20.79	18.79	0.0757
	376000	15KHZ 376000 DFT-s-OFDM 256QAM Edge 1RB Left	18.18	16.18	0.0415
	376000	15KHZ 376000 DFT-s-OFDM 256QAM Edge 1RB Right	18.27	16.27	0.0424
	376000	15KHZ 376000 DFT-s-OFDM 256QAM Outer Full	18.8	16.8	0.0479
	376000	15KHZ 376000 CP-OFDM QPSK Inner Full	21.9	19.9	0.0977
	376000	15KHZ 376000 CP-OFDM QPSK Edge 1RB Left	20.6	18.6	0.0724
	376000	15KHZ 376000 CP-OFDM QPSK Edge 1RB Right	20.6	18.6	0.0724
	376000	15KHZ 376000 CP-OFDM QPSK Outer Full	20.33	18.33	0.0681
	376000	15KHZ 376000 CP-OFDM 16QAM Inner Full	21.12	19.12	0.0817
	376000	15KHZ 376000 CP-OFDM 16QAM Edge 1RB Left	20.47	18.47	0.0703
	376000	15KHZ 376000 CP-OFDM 16QAM Edge 1RB Right	20.4	18.4	0.0692
	376000	15KHZ 376000 CP-OFDM 16QAM Outer Full	20.37	18.37	0.0687
	376000	15KHZ 376000 CP-OFDM 64QAM Edge 1RB Left	19.59	17.59	0.0574
	376000	15KHZ 376000 CP-OFDM 64QAM Edge 1RB Right	19.6	17.6	0.0575
	376000	15KHZ 376000 CP-OFDM 64QAM Outer Full	19.87	17.87	0.0612
	376000	15KHZ 376000 CP-OFDM 256QAM Edge 1RB Left	16.23	14.23	0.0265
	376000	15KHZ 376000 CP-OFDM 256QAM Edge 1RB Right	16.18	14.18	0.0262
	376000	15KHZ 376000 CP-OFDM 256QAM Outer Full	16.93	14.93	0.0311
	381000	15KHZ 381000 DFT-s-OFDM PI/2 BPSK Inner 1RB Right	23.1	21.1	0.1288
	381000	15KHZ 381000 DFT-s-OFDM PI/2 BPSK Inner 1RB Left	23.12	21.12	0.1294
	381000	15KHZ 381000 DFT-s-OFDM PI/2 BPSK Inner Full	23.17	21.17	0.1309
	381000	15KHZ 381000 DFT-s-OFDM QPSK Inner 1RB Right	23.07	21.07	0.1279
	381000	15KHZ 381000 DFT-s-OFDM QPSK Inner 1RB Left	23.1	21.1	0.1288
	381000	15KHZ 381000 DFT-s-OFDM QPSK Inner Full	23.18	21.18	0.1312
	381000	15KHZ 381000 DFT-s-OFDM PI/2 BPSK Outer Full	22.86	20.86	0.1219
	381000	15KHZ 381000 DFT-s-OFDM QPSK Outer Full	22.3	20.3	0.1072
	381000	15KHZ 381000 DFT-s-OFDM 16QAM Inner Full	22.29	20.29	0.1069
	381000	15KHZ 381000 DFT-s-OFDM 16QAM Edge 1RB Left	21.21	19.21	0.0834
	381000	15KHZ 381000 DFT-s-OFDM 16QAM Edge 1RB Right	21.18	19.18	0.0828
	381000	15KHZ 381000 DFT-s-OFDM 16QAM Outer Full	21.31	19.31	0.0853
	381000	15KHZ 381000 DFT-s-OFDM 64QAM Edge 1RB Left	20.8	18.8	0.0759
	381000	15KHZ 381000 DFT-s-OFDM 64QAM Edge 1RB Right	20.54	18.54	0.0714
	381000	15KHZ 381000 DFT-s-OFDM 64QAM Outer Full	20.73	18.73	0.0746
	381000	15KHZ 381000 DFT-s-OFDM 256QAM Edge 1RB Left	18.23	16.23	0.0420
	381000	15KHZ 381000 DFT-s-OFDM 256QAM Edge 1RB Right	18.03	16.03	0.0401
	381000	15KHZ 381000 DFT-s-OFDM 256QAM Outer Full	18.78	16.78	0.0476
	381000	15KHZ 381000 CP-OFDM QPSK Inner Full	21.84	19.84	0.0964
	381000	15KHZ 381000 CP-OFDM QPSK Edge 1RB Left	20.31	18.31	0.0678
	381000	15KHZ 381000 CP-OFDM QPSK Edge 1RB Right	20.39	18.39	0.0690
	381000	15KHZ 381000 CP-OFDM QPSK Outer Full	20.2	18.2	0.0661
	381000	15KHZ 381000 CP-OFDM 16QAM Inner Full	21.41	19.41	0.0873
	381000	15KHZ 381000 CP-OFDM 16QAM Edge 1RB Left	20.39	18.39	0.0690
	381000	15KHZ 381000 CP-OFDM 16QAM Edge 1RB Right	20.3	18.3	0.0676
	381000	15KHZ 381000 CP-OFDM 16QAM Outer Full	20.36	18.36	0.0685
	381000	15KHZ 381000 CP-OFDM 64QAM Edge 1RB Left	19.55	17.55	0.0569
	381000	15KHZ 381000 CP-OFDM 64QAM Edge 1RB Right	19.59	17.59	0.0574
	381000	15KHZ 381000 CP-OFDM 64QAM Outer Full	19.74	17.74	0.0594
	381000	15KHZ 381000 CP-OFDM 256QAM Edge 1RB Left	16.31	14.31	0.0270
	381000	15KHZ 381000 CP-OFDM 256QAM Edge 1RB Right	16.12	14.12	0.0258
	381000	15KHZ 381000 CP-OFDM 256QAM Outer Full	16.81	14.81	0.0303

5G NR n2- 15MHz	Channel	TestItem	MeasuredValue	EIRP POWER(dbm)	EIRP power(W)
	371500	15KHZ 371500	DFT-s-OFDM PI/2 BPSK Inner 1RB Right	23.23	21.23
371500	15KHZ 371500	DFT-s-OFDM PI/2 BPSK Inner 1RB Left	23.05	21.05	0.1274
371500	15KHZ 371500	DFT-s-OFDM PI/2 BPSK Inner Full	23.26	21.26	0.1337
371500	15KHZ 371500	DFT-s-OFDM QPSK Inner 1RB Right	23.24	21.24	0.1330
371500	15KHZ 371500	DFT-s-OFDM QPSK Inner 1RB Left	23.03	21.03	0.1268
371500	15KHZ 371500	DFT-s-OFDM QPSK Inner Full	23.07	21.07	0.1279
371500	15KHZ 371500	DFT-s-OFDM PI/2 BPSK Outer Full	22.95	20.95	0.1245
371500	15KHZ 371500	DFT-s-OFDM QPSK Outer Full	22.27	20.27	0.1064
371500	15KHZ 371500	DFT-s-OFDM 16QAM Inner Full	22.37	20.37	0.1089
371500	15KHZ 371500	DFT-s-OFDM 16QAM Edge 1RB Left	21.28	19.28	0.0847
371500	15KHZ 371500	DFT-s-OFDM 16QAM Edge 1RB Right	21.35	19.35	0.0861
371500	15KHZ 371500	DFT-s-OFDM 16QAM Outer Full	21.26	19.26	0.0843
371500	15KHZ 371500	DFT-s-OFDM 64QAM Edge 1RB Left	20.59	18.59	0.0723
371500	15KHZ 371500	DFT-s-OFDM 64QAM Edge 1RB Right	20.73	18.73	0.0746
371500	15KHZ 371500	DFT-s-OFDM 64QAM Outer Full	20.93	18.93	0.0782
371500	15KHZ 371500	DFT-s-OFDM 256QAM Edge 1RB Left	18.09	16.09	0.0406
371500	15KHZ 371500	DFT-s-OFDM 256QAM Edge 1RB Right	18.37	16.37	0.0434
371500	15KHZ 371500	DFT-s-OFDM 256QAM Outer Full	18.83	16.83	0.0482
371500	15KHZ 371500	CP-OFDM QPSK Inner Full	21.91	19.91	0.0979
371500	15KHZ 371500	CP-OFDM QPSK Edge 1RB Left	20.29	18.29	0.0675
371500	15KHZ 371500	CP-OFDM QPSK Edge 1RB Right	20.68	18.68	0.0738
371500	15KHZ 371500	CP-OFDM QPSK Outer Full	20.15	18.15	0.0653
371500	15KHZ 371500	CP-OFDM 16QAM Inner Full	20.69	18.69	0.0740
371500	15KHZ 371500	CP-OFDM 16QAM Edge 1RB Left	19.91	17.91	0.0618
371500	15KHZ 371500	CP-OFDM 16QAM Edge 1RB Right	19.99	17.99	0.0630
371500	15KHZ 371500	CP-OFDM 16QAM Outer Full	20.15	18.15	0.0653
371500	15KHZ 371500	CP-OFDM 64QAM Edge 1RB Left	19.02	17.02	0.0504
371500	15KHZ 371500	CP-OFDM 64QAM Edge 1RB Right	19.1	17.1	0.0513
371500	15KHZ 371500	CP-OFDM 64QAM Outer Full	19.72	17.72	0.0592
371500	15KHZ 371500	CP-OFDM 256QAM Edge 1RB Left	15.63	13.63	0.0231
371500	15KHZ 371500	CP-OFDM 256QAM Edge 1RB Right	15.63	13.63	0.0231
371500	15KHZ 371500	CP-OFDM 256QAM Outer Full	16.75	14.75	0.0299
376000	15KHZ 376000	DFT-s-OFDM PI/2 BPSK Inner 1RB Right	23.31	21.31	0.1352
376000	15KHZ 376000	DFT-s-OFDM PI/2 BPSK Inner 1RB Left	23.34	21.34	0.1361
376000	15KHZ 376000	DFT-s-OFDM PI/2 BPSK Inner Full	23.32	21.32	0.1355
376000	15KHZ 376000	DFT-s-OFDM QPSK Inner 1RB Right	23.32	21.32	0.1355
376000	15KHZ 376000	DFT-s-OFDM QPSK Inner 1RB Left	23.25	21.25	0.1334
376000	15KHZ 376000	DFT-s-OFDM QPSK Inner Full	23.37	21.37	0.1371
376000	15KHZ 376000	DFT-s-OFDM PI/2 BPSK Outer Full	22.94	20.94	0.1242
376000	15KHZ 376000	DFT-s-OFDM QPSK Outer Full	22.44	20.44	0.1107
376000	15KHZ 376000	DFT-s-OFDM 16QAM Inner Full	22.58	20.58	0.1143
376000	15KHZ 376000	DFT-s-OFDM 16QAM Edge 1RB Left	21.38	19.38	0.0867
376000	15KHZ 376000	DFT-s-OFDM 16QAM Edge 1RB Right	21.55	19.55	0.0902
376000	15KHZ 376000	DFT-s-OFDM 16QAM Outer Full	21.52	19.52	0.0895
376000	15KHZ 376000	DFT-s-OFDM 64QAM Edge 1RB Left	20.83	18.83	0.0764
376000	15KHZ 376000	DFT-s-OFDM 64QAM Edge 1RB Right	21	19	0.0794
376000	15KHZ 376000	DFT-s-OFDM 64QAM Outer Full	21.01	19.01	0.0796
376000	15KHZ 376000	DFT-s-OFDM 256QAM Edge 1RB Left	18.29	16.29	0.0426
376000	15KHZ 376000	DFT-s-OFDM 256QAM Edge 1RB Right	18.36	16.36	0.0433
376000	15KHZ 376000	DFT-s-OFDM 256QAM Outer Full	18.97	16.97	0.0498
376000	15KHZ 376000	CP-OFDM QPSK Inner Full	21.55	19.55	0.0902
376000	15KHZ 376000	CP-OFDM QPSK Edge 1RB Left	20.69	18.69	0.0740
376000	15KHZ 376000	CP-OFDM QPSK Edge 1RB Right	20.46	18.46	0.0701
376000	15KHZ 376000	CP-OFDM QPSK Outer Full	20.68	18.68	0.0738
376000	15KHZ 376000	CP-OFDM 16QAM Inner Full	21.5	19.5	0.0891
376000	15KHZ 376000	CP-OFDM 16QAM Edge 1RB Left	20.48	18.48	0.0705
376000	15KHZ 376000	CP-OFDM 16QAM Edge 1RB Right	20.57	18.57	0.0719
376000	15KHZ 376000	CP-OFDM 16QAM Outer Full	20.52	18.52	0.0711
376000	15KHZ 376000	CP-OFDM 64QAM Edge 1RB Left	19.69	17.69	0.0587
376000	15KHZ 376000	CP-OFDM 64QAM Edge 1RB Right	19.85	17.85	0.0610
376000	15KHZ 376000	CP-OFDM 64QAM Outer Full	19.97	17.97	0.0627
376000	15KHZ 376000	CP-OFDM 256QAM Edge 1RB Left	16.41	14.41	0.0276
376000	15KHZ 376000	CP-OFDM 256QAM Edge 1RB Right	16.27	14.27	0.0267
376000	15KHZ 376000	CP-OFDM 256QAM Outer Full	16.94	14.94	0.0312
380500	15KHZ 380500	DFT-s-OFDM PI/2 BPSK Inner 1RB Right	23.14	21.14	0.1300
380500	15KHZ 380500	DFT-s-OFDM PI/2 BPSK Inner 1RB Left	23.19	21.19	0.1315
380500	15KHZ 380500	DFT-s-OFDM PI/2 BPSK Inner Full	23.09	21.09	0.1285
380500	15KHZ 380500	DFT-s-OFDM QPSK Inner 1RB Right	23.05	21.05	0.1274
380500	15KHZ 380500	DFT-s-OFDM QPSK Inner 1RB Left	23.09	21.09	0.1285
380500	15KHZ 380500	DFT-s-OFDM QPSK Inner Full	23.1	21.1	0.1288
380500	15KHZ 380500	DFT-s-OFDM PI/2 BPSK Outer Full	22.78	20.78	0.1197
380500	15KHZ 380500	DFT-s-OFDM QPSK Outer Full	22.27	20.27	0.1064
380500	15KHZ 380500	DFT-s-OFDM 16QAM Inner Full	22.05	20.05	0.1012
380500	15KHZ 380500	DFT-s-OFDM 16QAM Edge 1RB Left	21.13	19.13	0.0818
380500	15KHZ 380500	DFT-s-OFDM 16QAM Edge 1RB Right	21.12	19.12	0.0817
380500	15KHZ 380500	DFT-s-OFDM 16QAM Outer Full	20.99	18.99	0.0793
380500	15KHZ 380500	DFT-s-OFDM 64QAM Edge 1RB Left	20.48	18.48	0.0705
380500	15KHZ 380500	DFT-s-OFDM 64QAM Edge 1RB Right	20.58	18.58	0.0721
380500	15KHZ 380500	DFT-s-OFDM 64QAM Outer Full	20.66	18.66	0.0735
380500	15KHZ 380500	DFT-s-OFDM 256QAM Edge 1RB Left	18.14	16.14	0.0411
380500	15KHZ 380500	DFT-s-OFDM 256QAM Edge 1RB Right	18.09	16.09	0.0406
380500	15KHZ 380500	DFT-s-OFDM 256QAM Outer Full	18.75	16.75	0.0473
380500	15KHZ 380500	CP-OFDM QPSK Inner Full	21.36	19.36	0.0863
380500	15KHZ 380500	CP-OFDM QPSK Edge 1RB Left	20.26	18.26	0.0670
380500	15KHZ 380500	CP-OFDM QPSK Edge 1RB Right	20.45	18.45	0.0700
380500	15KHZ 380500	CP-OFDM QPSK Outer Full	20.24	18.24	0.0667
380500	15KHZ 380500	CP-OFDM 16QAM Inner Full	21.04	19.04	0.0802
380500	15KHZ 380500	CP-OFDM 16QAM Edge 1RB Left	20.4	18.4	0.0692
380500	15KHZ 380500	CP-OFDM 16QAM Edge 1RB Right	20.27	18.27	0.0671
380500	15KHZ 380500	CP-OFDM 16QAM Outer Full	20.19	18.19	0.0659
380500	15KHZ 380500	CP-OFDM 64QAM Edge 1RB Left	19.58	17.58	0.0573
380500	15KHZ 380500	CP-OFDM 64QAM Edge 1RB Right	19.42	17.42	0.0552
380500	15KHZ 380500	CP-OFDM 64QAM Outer Full	19.86	17.86	0.0611
380500	15KHZ 380500	CP-OFDM 256QAM Edge 1RB Left	16.21	14.21	0.0264
380500	15KHZ 380500	CP-OFDM 256QAM Edge 1RB Right	15.98	13.98	0.0250
380500	15KHZ 380500	CP-OFDM 256QAM Outer Full	16.81	14.81	0.0303

5G NR n2- 20MHz	Channel	TestItem	MeasuredValue	EIRP POWER(dbm)	EIRP power(W)
		372000	15KHZ 372000 DFT-s-OFDM PI/2 BPSK Inner 1RB Right	23.3	21.3
	372000	15KHZ 372000 DFT-s-OFDM PI/2 BPSK Inner 1RB Left	23.67	21.67	0.1469
	372000	15KHZ 372000 DFT-s-OFDM PI/2 BPSK Inner Full	23.12	21.12	0.1294
	372000	15KHZ 372000 DFT-s-OFDM QPSK Inner 1RB Right	23.15	21.15	0.1303
	372000	15KHZ 372000 DFT-s-OFDM QPSK Inner 1RB Left	23.07	21.07	0.1279
	372000	15KHZ 372000 DFT-s-OFDM QPSK Inner Full	23.15	21.15	0.1303
	372000	15KHZ 372000 DFT-s-OFDM PI/2 BPSK Outer Full	22.86	20.86	0.1219
	372000	15KHZ 372000 DFT-s-OFDM QPSK Outer Full	22.31	20.31	0.1074
	372000	15KHZ 372000 DFT-s-OFDM 16QAM Inner Full	22.31	20.31	0.1074
	372000	15KHZ 372000 DFT-s-OFDM 16QAM Edge 1RB Left	21.22	19.22	0.0836
	372000	15KHZ 372000 DFT-s-OFDM 16QAM Edge 1RB Right	21.34	19.34	0.0859
	372000	15KHZ 372000 DFT-s-OFDM 16QAM Outer Full	21.37	19.37	0.0865
	372000	15KHZ 372000 DFT-s-OFDM 64QAM Edge 1RB Left	20.63	18.63	0.0729
	372000	15KHZ 372000 DFT-s-OFDM 64QAM Edge 1RB Right	20.63	18.63	0.0729
	372000	15KHZ 372000 DFT-s-OFDM 64QAM Outer Full	20.82	18.82	0.0762
	372000	15KHZ 372000 DFT-s-OFDM 256QAM Edge 1RB Left	18.15	16.15	0.0412
	372000	15KHZ 372000 DFT-s-OFDM 256QAM Edge 1RB Right	18.29	16.29	0.0426
	372000	15KHZ 372000 DFT-s-OFDM 256QAM Outer Full	18.83	16.83	0.0482
	372000	15KHZ 372000 CP-OFDM QPSK Inner Full	21.42	19.42	0.0875
	372000	15KHZ 372000 CP-OFDM QPSK Edge 1RB Left	20.32	18.32	0.0679
	372000	15KHZ 372000 CP-OFDM QPSK Edge 1RB Right	20.42	18.42	0.0695
	372000	15KHZ 372000 CP-OFDM QPSK Outer Full	20.33	18.33	0.0681
	372000	15KHZ 372000 CP-OFDM 16QAM Inner Full	21.3	19.3	0.0851
	372000	15KHZ 372000 CP-OFDM 16QAM Edge 1RB Left	20.34	18.34	0.0682
	372000	15KHZ 372000 CP-OFDM 16QAM Edge 1RB Right	20.46	18.46	0.0701
	372000	15KHZ 372000 CP-OFDM 16QAM Outer Full	20.33	18.33	0.0681
	372000	15KHZ 372000 CP-OFDM 64QAM Edge 1RB Left	19.48	17.48	0.0560
	372000	15KHZ 372000 CP-OFDM 64QAM Edge 1RB Right	19.63	17.63	0.0579
	372000	15KHZ 372000 CP-OFDM 64QAM Outer Full	19.86	17.86	0.0611
	372000	15KHZ 372000 CP-OFDM 256QAM Edge 1RB Left	16.03	14.03	0.0253
	372000	15KHZ 372000 CP-OFDM 256QAM Edge 1RB Right	16.15	14.15	0.0260
	372000	15KHZ 372000 CP-OFDM 256QAM Outer Full	16.87	14.87	0.0307
	376000	15KHZ 376000 DFT-s-OFDM PI/2 BPSK Inner 1RB Right	23.1	21.1	0.1288
	376000	15KHZ 376000 DFT-s-OFDM PI/2 BPSK Inner 1RB Left	23.1	21.1	0.1288
	376000	15KHZ 376000 DFT-s-OFDM PI/2 BPSK Inner Full	23.18	21.18	0.1312
	376000	15KHZ 376000 DFT-s-OFDM QPSK Inner 1RB Right	23.25	21.25	0.1334
	376000	15KHZ 376000 DFT-s-OFDM QPSK Inner 1RB Left	23.18	21.18	0.1312
	376000	15KHZ 376000 DFT-s-OFDM QPSK Inner Full	23.3	21.3	0.1349
	376000	15KHZ 376000 DFT-s-OFDM PI/2 BPSK Outer Full	22.94	20.94	0.1242
	376000	15KHZ 376000 DFT-s-OFDM QPSK Outer Full	22.44	20.44	0.1107
	376000	15KHZ 376000 DFT-s-OFDM 16QAM Inner Full	22.56	20.56	0.1138
	376000	15KHZ 376000 DFT-s-OFDM 16QAM Edge 1RB Left	21.28	19.28	0.0847
	376000	15KHZ 376000 DFT-s-OFDM 16QAM Edge 1RB Right	21.43	19.43	0.0877
	376000	15KHZ 376000 DFT-s-OFDM 16QAM Outer Full	21.46	19.46	0.0883
	376000	15KHZ 376000 DFT-s-OFDM 64QAM Edge 1RB Left	20.67	18.67	0.0736
	376000	15KHZ 376000 DFT-s-OFDM 64QAM Edge 1RB Right	20.85	18.85	0.0767
	376000	15KHZ 376000 DFT-s-OFDM 64QAM Outer Full	20.91	18.91	0.0778
	376000	15KHZ 376000 DFT-s-OFDM 256QAM Edge 1RB Left	18.27	16.27	0.0424
	376000	15KHZ 376000 DFT-s-OFDM 256QAM Edge 1RB Right	18.26	16.26	0.0423
	376000	15KHZ 376000 DFT-s-OFDM 256QAM Outer Full	18.93	16.93	0.0493
	376000	15KHZ 376000 CP-OFDM QPSK Inner Full	21.95	19.95	0.0989
	376000	15KHZ 376000 CP-OFDM QPSK Edge 1RB Left	20.46	18.46	0.0701
	376000	15KHZ 376000 CP-OFDM QPSK Edge 1RB Right	20.6	18.6	0.0724
	376000	15KHZ 376000 CP-OFDM QPSK Outer Full	20.4	18.4	0.0692
	376000	15KHZ 376000 CP-OFDM 16QAM Inner Full	21.49	19.49	0.0889
	376000	15KHZ 376000 CP-OFDM 16QAM Edge 1RB Left	20.46	18.46	0.0701
	376000	15KHZ 376000 CP-OFDM 16QAM Edge 1RB Right	20.38	18.38	0.0689
	376000	15KHZ 376000 CP-OFDM 16QAM Outer Full	20.41	18.41	0.0693
	376000	15KHZ 376000 CP-OFDM 64QAM Edge 1RB Left	19.62	17.62	0.0578
	376000	15KHZ 376000 CP-OFDM 64QAM Edge 1RB Right	19.71	17.71	0.0590
	376000	15KHZ 376000 CP-OFDM 64QAM Outer Full	19.95	17.95	0.0624
	376000	15KHZ 376000 CP-OFDM 256QAM Edge 1RB Left	16.16	14.16	0.0261
	376000	15KHZ 376000 CP-OFDM 256QAM Edge 1RB Right	16.11	14.11	0.0258
	376000	15KHZ 376000 CP-OFDM 256QAM Outer Full	16.91	14.91	0.0310
	380000	15KHZ 380000 DFT-s-OFDM PI/2 BPSK Inner 1RB Right	23.08	21.08	0.1282
	380000	15KHZ 380000 DFT-s-OFDM PI/2 BPSK Inner 1RB Left	23.25	21.25	0.1334
	380000	15KHZ 380000 DFT-s-OFDM PI/2 BPSK Inner Full	23.27	21.27	0.1340
	380000	15KHZ 380000 DFT-s-OFDM QPSK Inner 1RB Right	22.99	20.99	0.1256
	380000	15KHZ 380000 DFT-s-OFDM QPSK Inner 1RB Left	23.23	21.23	0.1327
	380000	15KHZ 380000 DFT-s-OFDM QPSK Inner Full	23.08	21.08	0.1282
	380000	15KHZ 380000 DFT-s-OFDM PI/2 BPSK Outer Full	22.81	20.81	0.1205
	380000	15KHZ 380000 DFT-s-OFDM QPSK Outer Full	22.24	20.24	0.1057
	380000	15KHZ 380000 DFT-s-OFDM 16QAM Inner Full	22.21	20.21	0.1050
	380000	15KHZ 380000 DFT-s-OFDM 16QAM Edge 1RB Left	21.36	19.36	0.0863
	380000	15KHZ 380000 DFT-s-OFDM 16QAM Edge 1RB Right	21.19	19.19	0.0830
	380000	15KHZ 380000 DFT-s-OFDM 16QAM Outer Full	21.38	19.38	0.0867
	380000	15KHZ 380000 DFT-s-OFDM 64QAM Edge 1RB Left	20.76	18.76	0.0752
	380000	15KHZ 380000 DFT-s-OFDM 64QAM Edge 1RB Right	20.51	18.51	0.0710
	380000	15KHZ 380000 DFT-s-OFDM 64QAM Outer Full	20.79	18.79	0.0757
	380000	15KHZ 380000 DFT-s-OFDM 256QAM Edge 1RB Left	18.36	16.36	0.0433
	380000	15KHZ 380000 DFT-s-OFDM 256QAM Edge 1RB Right	18.03	16.03	0.0401
	380000	15KHZ 380000 DFT-s-OFDM 256QAM Outer Full	18.8	16.8	0.0479
	380000	15KHZ 380000 CP-OFDM QPSK Inner Full	21.41	19.41	0.0873
	380000	15KHZ 380000 CP-OFDM QPSK Edge 1RB Left	20.51	18.51	0.0710
	380000	15KHZ 380000 CP-OFDM QPSK Edge 1RB Right	20.18	18.18	0.0658
	380000	15KHZ 380000 CP-OFDM QPSK Outer Full	20.31	18.31	0.0678
	380000	15KHZ 380000 CP-OFDM 16QAM Inner Full	20.54	18.54	0.0714
	380000	15KHZ 380000 CP-OFDM 16QAM Edge 1RB Left	19.72	17.72	0.0592
	380000	15KHZ 380000 CP-OFDM 16QAM Edge 1RB Right	19.52	17.52	0.0565
	380000	15KHZ 380000 CP-OFDM 16QAM Outer Full	20.23	18.23	0.0665
	380000	15KHZ 380000 CP-OFDM 64QAM Edge 1RB Left	18.79	16.79	0.0478
	380000	15KHZ 380000 CP-OFDM 64QAM Edge 1RB Right	18.59	16.59	0.0456
	380000	15KHZ 380000 CP-OFDM 64QAM Outer Full	19.8	17.8	0.0603
	380000	15KHZ 380000 CP-OFDM 256QAM Edge 1RB Left	15.23	13.23	0.0210
	380000	15KHZ 380000 CP-OFDM 256QAM Edge 1RB Right	15.01	13.01	0.0200
	380000	15KHZ 380000 CP-OFDM 256QAM Outer Full	16.9	14.9	0.0309

5G NR	Channel	TestItem	MeasuredValue	EIRP power (dbm)	EIRP power (W)
n25-5MHZ	370500	15KHZ 370500 DFT-s-OFDM PI/2 BPSK Inner IRB Right	23.52	21.52	0.1419
	370500	15KHZ 370500 DFT-s-OFDM PI/2 BPSK Inner IRB Left	23.51	21.51	0.1416
	370500	15KHZ 370500 DFT-s-OFDM PI/2 BPSK Inner Full	23.57	21.57	0.1435
	370500	15KHZ 370500 DFT-s-OFDM QPSK Inner IRB Right	23.54	21.54	0.1426
	370500	15KHZ 370500 DFT-s-OFDM QPSK Inner IRB Left	23.52	21.52	0.1419
	370500	15KHZ 370500 DFT-s-OFDM QPSK Inner Full	23.47	21.47	0.1403
	370500	15KHZ 370500 DFT-s-OFDM PI/2 BPSK Edge IRB Left	22.89	20.89	0.1227
	370500	15KHZ 370500 DFT-s-OFDM PI/2 BPSK Edge IRB Right	23.02	21.02	0.1265
	370500	15KHZ 370500 DFT-s-OFDM PI/2 BPSK Outer Full	22.97	20.97	0.1250
	370500	15KHZ 370500 DFT-s-OFDM PI/2 BPSK Inner Full	23.47	21.47	0.1403
	370500	15KHZ 370500 DFT-s-OFDM PI/2 BPSK Edge IRB Left	23	21.00	0.1259
	370500	15KHZ 370500 DFT-s-OFDM PI/2 BPSK Edge IRB Right	23.03	21.03	0.1268
	370500	15KHZ 370500 DFT-s-OFDM PI/2 BPSK Outer Full	22.97	20.97	0.1250
	370500	15KHZ 370500 DFT-s-OFDM QPSK Inner Full	23.49	21.49	0.1409
	370500	15KHZ 370500 DFT-s-OFDM QPSK Edge IRB Left	22.38	20.38	0.1091
	370500	15KHZ 370500 DFT-s-OFDM QPSK Edge IRB Right	22.41	20.41	0.1099
	370500	15KHZ 370500 DFT-s-OFDM QPSK Outer Full	22.51	20.51	0.1125
	370500	15KHZ 370500 DFT-s-OFDM 16QAM Inner Full	22.55	20.55	0.1135
	370500	15KHZ 370500 DFT-s-OFDM 16QAM Edge IRB Left	21.44	19.44	0.0879
	370500	15KHZ 370500 DFT-s-OFDM 16QAM Edge IRB Right	21.46	19.46	0.0883
	370500	15KHZ 370500 DFT-s-OFDM 16QAM Outer Full	21.57	19.57	0.0906
	370500	15KHZ 370500 DFT-s-OFDM 64QAM Edge IRB Left	20.78	18.78	0.0755
	370500	15KHZ 370500 DFT-s-OFDM 64QAM Edge IRB Right	20.79	18.79	0.0757
	370500	15KHZ 370500 DFT-s-OFDM 64QAM Outer Full	21	19.00	0.0794
	370500	15KHZ 370500 DFT-s-OFDM 256QAM Edge IRB Left	18.41	16.41	0.0438
	370500	15KHZ 370500 DFT-s-OFDM 256QAM Edge IRB Right	18.45	16.45	0.0442
	370500	15KHZ 370500 DFT-s-OFDM 256QAM Outer Full	18.82	16.82	0.0481
	370500	15KHZ 370500 CP-OFDM QPSK Inner Full	21.96	19.96	0.0991
	370500	15KHZ 370500 CP-OFDM QPSK Edge IRB Left	20.62	18.62	0.0728
	370500	15KHZ 370500 CP-OFDM QPSK Edge IRB Right	20.5	18.50	0.0708
	370500	15KHZ 370500 CP-OFDM QPSK Outer Full	20.4	18.40	0.0692
	370500	15KHZ 370500 CP-OFDM 16QAM Inner Full	21.35	19.35	0.0861
	370500	15KHZ 370500 CP-OFDM 16QAM Edge IRB Left	20.52	18.52	0.0711
	370500	15KHZ 370500 CP-OFDM 16QAM Edge IRB Right	20.5	18.50	0.0708
	370500	15KHZ 370500 CP-OFDM 16QAM Outer Full	20.57	18.57	0.0719
	370500	15KHZ 370500 CP-OFDM 64QAM Edge IRB Left	19.69	17.69	0.0587
	370500	15KHZ 370500 CP-OFDM 64QAM Edge IRB Right	19.79	17.79	0.0601
	370500	15KHZ 370500 CP-OFDM 64QAM Outer Full	20	18.00	0.0631
	370500	15KHZ 370500 CP-OFDM 256QAM Edge IRB Left	16.31	14.31	0.0270
	370500	15KHZ 370500 CP-OFDM 256QAM Edge IRB Right	16.31	14.31	0.0270
	370500	15KHZ 370500 CP-OFDM 256QAM Outer Full	16.96	14.96	0.0313
	376500	15KHZ 376500 DFT-s-OFDM PI/2 BPSK Inner IRB Right	23.56	21.56	0.1432
	376500	15KHZ 376500 DFT-s-OFDM PI/2 BPSK Inner IRB Left	23.35	21.35	0.1365
	376500	15KHZ 376500 DFT-s-OFDM PI/2 BPSK Inner Full	23.43	21.43	0.1390
	376500	15KHZ 376500 DFT-s-OFDM QPSK Inner IRB Right	23.35	21.35	0.1365
	376500	15KHZ 376500 DFT-s-OFDM QPSK Inner IRB Left	23.47	21.47	0.1403
	376500	15KHZ 376500 DFT-s-OFDM QPSK Inner Full	23.35	21.35	0.1365
	376500	15KHZ 376500 DFT-s-OFDM PI/2 BPSK Edge IRB Left	22.84	20.84	0.1213
	376500	15KHZ 376500 DFT-s-OFDM PI/2 BPSK Edge IRB Right	22.96	20.96	0.1247
	376500	15KHZ 376500 DFT-s-OFDM PI/2 BPSK Outer Full	22.95	20.95	0.1245
	376500	15KHZ 376500 DFT-s-OFDM PI/2 BPSK Inner Full	23.42	21.42	0.1387
	376500	15KHZ 376500 DFT-s-OFDM PI/2 BPSK Edge IRB Left	22.81	20.81	0.1205
	376500	15KHZ 376500 DFT-s-OFDM PI/2 BPSK Edge IRB Right	22.87	20.87	0.1222
	376500	15KHZ 376500 DFT-s-OFDM PI/2 BPSK Outer Full	22.8	20.80	0.1202
	376500	15KHZ 376500 DFT-s-OFDM QPSK Inner Full	23.31	21.31	0.1352
	376500	15KHZ 376500 DFT-s-OFDM QPSK Edge IRB Left	22.36	20.36	0.1086
	376500	15KHZ 376500 DFT-s-OFDM QPSK Edge IRB Right	22.42	20.42	0.1102
	376500	15KHZ 376500 DFT-s-OFDM QPSK Outer Full	22.42	20.42	0.1102
	376500	15KHZ 376500 DFT-s-OFDM 16QAM Inner Full	22.23	20.23	0.1054
	376500	15KHZ 376500 DFT-s-OFDM 16QAM Edge IRB Left	21.3	19.30	0.0851
	376500	15KHZ 376500 DFT-s-OFDM 16QAM Edge IRB Right	21.37	19.36	0.0863
	376500	15KHZ 376500 DFT-s-OFDM 16QAM Outer Full	21.36	19.37	0.0865
	376500	15KHZ 376500 DFT-s-OFDM 64QAM Edge IRB Left	20.75	18.75	0.0750
	376500	15KHZ 376500 DFT-s-OFDM 64QAM Edge IRB Right	20.71	18.71	0.0743
	376500	15KHZ 376500 DFT-s-OFDM 64QAM Outer Full	20.94	18.94	0.0783
	376500	15KHZ 376500 DFT-s-OFDM 256QAM Edge IRB Left	18.33	16.33	0.0430
	376500	15KHZ 376500 DFT-s-OFDM 256QAM Edge IRB Right	18.33	16.33	0.0430
	376500	15KHZ 376500 DFT-s-OFDM 256QAM Outer Full	18.91	16.91	0.0491
	376500	15KHZ 376500 CP-OFDM QPSK Inner Full	21.91	19.91	0.0979
	376500	15KHZ 376500 CP-OFDM QPSK Edge IRB Left	20.58	18.58	0.0721
	376500	15KHZ 376500 CP-OFDM QPSK Edge IRB Right	20.49	18.49	0.0706
	376500	15KHZ 376500 CP-OFDM QPSK Outer Full	20.36	18.36	0.0685
	376500	15KHZ 376500 CP-OFDM 16QAM Inner Full	21.36	19.36	0.0863
	376500	15KHZ 376500 CP-OFDM 16QAM Edge IRB Left	20.45	18.45	0.0700
	376500	15KHZ 376500 CP-OFDM 16QAM Edge IRB Right	20.46	18.46	0.0701
	376500	15KHZ 376500 CP-OFDM 16QAM Outer Full	20.46	18.46	0.0701
	376500	15KHZ 376500 CP-OFDM 64QAM Edge IRB Left	19.68	17.68	0.0586
	376500	15KHZ 376500 CP-OFDM 64QAM Edge IRB Right	19.57	17.57	0.0571
	376500	15KHZ 376500 CP-OFDM 64QAM Outer Full	19.93	17.93	0.0621
	376500	15KHZ 376500 CP-OFDM 256QAM Edge IRB Left	16.23	14.23	0.0265
	376500	15KHZ 376500 CP-OFDM 256QAM Edge IRB Right	16.23	14.23	0.0265
	376500	15KHZ 376500 CP-OFDM 256QAM Outer Full	16.85	14.85	0.0305
	382500	15KHZ 382500 DFT-s-OFDM PI/2 BPSK Inner IRB Right	23.38	21.38	0.1374
	382500	15KHZ 382500 DFT-s-OFDM PI/2 BPSK Inner IRB Left	23.3	21.30	0.1349
	382500	15KHZ 382500 DFT-s-OFDM PI/2 BPSK Inner Full	23.38	21.38	0.1374
	382500	15KHZ 382500 DFT-s-OFDM QPSK Inner IRB Right	23.4	21.40	0.1380
	382500	15KHZ 382500 DFT-s-OFDM QPSK Inner IRB Left	23.28	21.28	0.1343
	382500	15KHZ 382500 DFT-s-OFDM QPSK Inner Full	23.3	21.30	0.1349
	382500	15KHZ 382500 DFT-s-OFDM PI/2 BPSK Edge IRB Left	22.81	20.81	0.1205
	382500	15KHZ 382500 DFT-s-OFDM PI/2 BPSK Edge IRB Right	22.81	20.81	0.1205
	382500	15KHZ 382500 DFT-s-OFDM PI/2 BPSK Outer Full	22.86	20.86	0.1219
	382500	15KHZ 382500 DFT-s-OFDM PI/2 BPSK Inner Full	23.35	21.35	0.1365
	382500	15KHZ 382500 DFT-s-OFDM PI/2 BPSK Edge IRB Left	22.79	20.79	0.1199
	382500	15KHZ 382500 DFT-s-OFDM PI/2 BPSK Edge IRB Right	22.91	20.91	0.1233
	382500	15KHZ 382500 DFT-s-OFDM PI/2 BPSK Outer Full	22.88	20.88	0.1225
	382500	15KHZ 382500 DFT-s-OFDM QPSK Inner Full	23.29	21.29	0.1346
	382500	15KHZ 382500 DFT-s-OFDM QPSK Edge IRB Left	22.24	20.24	0.1057
	382500	15KHZ 382500 DFT-s-OFDM QPSK Edge IRB Right	22.26	20.26	0.1062
	382500	15KHZ 382500 DFT-s-OFDM QPSK Outer Full	22.32	20.32	0.1076
	382500	15KHZ 382500 DFT-s-OFDM 16QAM Inner Full	22.51	20.51	0.1125
382500	15KHZ 382500 DFT-s-OFDM 16QAM Edge IRB Left	21.32	19.32	0.0855	
382500	15KHZ 382500 DFT-s-OFDM 16QAM Edge IRB Right	21.32	19.32	0.0855	
382500	15KHZ 382500 DFT-s-OFDM 16QAM Outer Full	21.43	19.43	0.0877	
382500	15KHZ 382500 DFT-s-OFDM 64QAM Edge IRB Left	20.68	18.68	0.0738	
382500	15KHZ 382500 DFT-s-OFDM 64QAM Edge IRB Right	20.55	18.55	0.0716	
382500	15KHZ 382500 DFT-s-OFDM 64QAM Outer Full	20.84	18.84	0.0766	
382500	15KHZ 382500 DFT-s-OFDM 256QAM Edge IRB Left	18.28	16.28	0.0425	
382500	15KHZ 382500 DFT-s-OFDM 256QAM Edge IRB Right	18.33	16.33	0.0430	
382500	15KHZ 382500 DFT-s-OFDM 256QAM Outer Full	18.8	16.80	0.0470	
382500	15KHZ 382500 CP-OFDM QPSK Inner Full	21.4	19.40	0.0871	
382500	15KHZ 382500 CP-OFDM QPSK Edge IRB Left	20.41	18.41	0.0693	
382500	15KHZ 382500 CP-OFDM QPSK Edge IRB Right	20.56	18.56	0.0718	
382500	15KHZ 382500 CP-OFDM QPSK Outer Full	20.35	18.35	0.0684	
382500	15KHZ 382500 CP-OFDM 16QAM Inner Full	21.25	19.25	0.0841	
382500	15KHZ 382500 CP-OFDM 16QAM Edge IRB Left	20.45	18.45	0.0700	
382500	15KHZ 382500 CP-OFDM 16QAM Edge IRB Right	20.44	18.44	0.0698	
382500	15KHZ 382500 CP-OFDM 16QAM Outer Full	20.53	18.53	0.0713	
382500	15KHZ 382500 CP-OFDM 64QAM Edge IRB Left	19.58	17.58	0.0573	
382500	15KHZ 382500 CP-OFDM 64QAM Edge IRB Right	19.63	17.63	0.0579	
382500	15KHZ 382500 CP-OFDM 64QAM Outer Full	19.92	17.92	0.0619	
382500	15KHZ 382500 CP-OFDM 256QAM Edge IRB Left	16.2	14.20	0.0263	
382500	15KHZ 382500 CP-OFDM 256QAM Edge IRB Right	16.12	14.12	0.0258	
382500	15KHZ 382500 CP-OFDM 256QAM Outer Full	16.82	14.82	0.0303	

5G NR
n25-
10MHZ

Channel	TestItem	MeasuredValue	EIRP power (dbm)	EIRP power (W)
371000	15KHZ 371000 DFT-s-OFDM P1/2 BPSK Inner 1RB Right	23.5	21.50	0.1413
371000	15KHZ 371000 DFT-s-OFDM P1/2 BPSK Inner 1RB Left	23.49	21.49	0.1409
371000	15KHZ 371000 DFT-s-OFDM P1/2 BPSK Inner Full	23.68	21.68	0.1472
371000	15KHZ 371000 DFT-s-OFDM QPSK Inner 1RB Right	23.56	21.56	0.1432
371000	15KHZ 371000 DFT-s-OFDM QPSK Inner 1RB Left	23.45	21.45	0.1396
371000	15KHZ 371000 DFT-s-OFDM QPSK Inner Full	23.64	21.64	0.1459
371000	15KHZ 371000 DFT-s-OFDM P1/2 BPSK Inner Full	23.46	21.46	0.1400
371000	15KHZ 371000 DFT-s-OFDM P1/2 BPSK Edge 1RB Left	23.02	21.02	0.1265
371000	15KHZ 371000 DFT-s-OFDM P1/2 BPSK Edge 1RB Right	23.02	21.02	0.1265
371000	15KHZ 371000 DFT-s-OFDM P1/2 BPSK Outer Full	23.03	21.03	0.1268
371000	15KHZ 371000 DFT-s-OFDM P1/2 BPSK Inner Full	23.73	21.73	0.1489
371000	15KHZ 371000 DFT-s-OFDM P1/2 BPSK Edge 1RB Left	22.99	20.99	0.1256
371000	15KHZ 371000 DFT-s-OFDM P1/2 BPSK Edge 1RB Right	22.99	20.99	0.1256
371000	15KHZ 371000 DFT-s-OFDM P1/2 BPSK Outer Full	23.07	21.07	0.1474
371000	15KHZ 371000 DFT-s-OFDM QPSK Inner Full	23.61	21.61	0.1449
371000	15KHZ 371000 DFT-s-OFDM QPSK Edge 1RB Left	22.56	20.56	0.1138
371000	15KHZ 371000 DFT-s-OFDM QPSK Edge 1RB Right	22.45	20.45	0.1109
371000	15KHZ 371000 DFT-s-OFDM QPSK Outer Full	22.55	20.55	0.1135
371000	15KHZ 371000 DFT-s-OFDM 16QAM Inner Full	22.63	20.63	0.1156
371000	15KHZ 371000 DFT-s-OFDM 16QAM Edge 1RB Left	21.52	19.52	0.0895
371000	15KHZ 371000 DFT-s-OFDM 16QAM Edge 1RB Right	21.43	19.43	0.0877
371000	15KHZ 371000 DFT-s-OFDM 16QAM Outer Full	21.46	19.46	0.0883
371000	15KHZ 371000 DFT-s-OFDM 64QAM Edge 1RB Left	20.95	18.95	0.0785
371000	15KHZ 371000 DFT-s-OFDM 64QAM Edge 1RB Right	20.85	18.85	0.0767
371000	15KHZ 371000 DFT-s-OFDM 64QAM Outer Full	21	19.00	0.0794
371000	15KHZ 371000 DFT-s-OFDM 256QAM Edge 1RB Left	18.41	16.41	0.0433
371000	15KHZ 371000 DFT-s-OFDM 256QAM Edge 1RB Right	18.44	16.44	0.0441
371000	15KHZ 371000 DFT-s-OFDM 256QAM Outer Full	18.99	16.99	0.0500
371000	15KHZ 371000 CP-OFDM QPSK Inner Full	22.04	20.04	0.1009
371000	15KHZ 371000 CP-OFDM QPSK Edge 1RB Left	20.46	18.46	0.0701
371000	15KHZ 371000 CP-OFDM QPSK Edge 1RB Right	20.75	18.75	0.0750
371000	15KHZ 371000 CP-OFDM QPSK Outer Full	20.49	18.49	0.0706
371000	15KHZ 371000 CP-OFDM 16QAM Inner Full	21.27	19.27	0.0845
371000	15KHZ 371000 CP-OFDM 16QAM Edge 1RB Left	20.61	18.61	0.0726
371000	15KHZ 371000 CP-OFDM 16QAM Edge 1RB Right	20.56	18.56	0.0718
371000	15KHZ 371000 CP-OFDM 16QAM Outer Full	20.57	18.57	0.0719
371000	15KHZ 371000 CP-OFDM 64QAM Edge 1RB Left	19.81	17.81	0.0604
371000	15KHZ 371000 CP-OFDM 64QAM Edge 1RB Right	19.69	17.69	0.0587
371000	15KHZ 371000 CP-OFDM 64QAM Outer Full	19.98	17.98	0.0628
371000	15KHZ 371000 CP-OFDM 256QAM Edge 1RB Left	16.34	14.34	0.0272
371000	15KHZ 371000 CP-OFDM 256QAM Edge 1RB Right	16.36	14.36	0.0273
371000	15KHZ 371000 CP-OFDM 256QAM Outer Full	17.11	15.11	0.0324
376500	15KHZ 376500 DFT-s-OFDM P1/2 BPSK Inner 1RB Right	23.45	21.45	0.1396
376500	15KHZ 376500 DFT-s-OFDM P1/2 BPSK Inner 1RB Left	23.39	21.39	0.1377
376500	15KHZ 376500 DFT-s-OFDM P1/2 BPSK Inner Full	23.6	21.60	0.1445
376500	15KHZ 376500 DFT-s-OFDM QPSK Inner 1RB Right	23.38	21.38	0.1374
376500	15KHZ 376500 DFT-s-OFDM QPSK Inner 1RB Left	23.32	21.32	0.1355
376500	15KHZ 376500 DFT-s-OFDM QPSK Inner Full	23.51	21.51	0.1416
376500	15KHZ 376500 DFT-s-OFDM P1/2 BPSK Inner Full	23.43	21.43	0.1390
376500	15KHZ 376500 DFT-s-OFDM P1/2 BPSK Edge 1RB Left	22.83	20.83	0.1211
376500	15KHZ 376500 DFT-s-OFDM P1/2 BPSK Edge 1RB Right	22.86	20.86	0.1213
376500	15KHZ 376500 DFT-s-OFDM P1/2 BPSK Outer Full	22.94	20.94	0.1242
376500	15KHZ 376500 DFT-s-OFDM P1/2 BPSK Inner Full	23.57	21.57	0.1435
376500	15KHZ 376500 DFT-s-OFDM P1/2 BPSK Edge 1RB Left	22.78	20.78	0.1197
376500	15KHZ 376500 DFT-s-OFDM P1/2 BPSK Edge 1RB Right	22.85	20.85	0.1216
376500	15KHZ 376500 DFT-s-OFDM P1/2 BPSK Outer Full	22.94	20.94	0.1242
376500	15KHZ 376500 DFT-s-OFDM QPSK Inner Full	23.51	21.51	0.1416
376500	15KHZ 376500 DFT-s-OFDM QPSK Edge 1RB Left	22.29	20.29	0.1069
376500	15KHZ 376500 DFT-s-OFDM QPSK Edge 1RB Right	22.44	20.44	0.1107
376500	15KHZ 376500 DFT-s-OFDM QPSK Outer Full	22.37	20.37	0.1089
376500	15KHZ 376500 DFT-s-OFDM 16QAM Inner Full	22.4	20.40	0.1096
376500	15KHZ 376500 DFT-s-OFDM 16QAM Edge 1RB Left	21.27	19.27	0.0845
376500	15KHZ 376500 DFT-s-OFDM 16QAM Edge 1RB Right	21.35	19.35	0.0861
376500	15KHZ 376500 DFT-s-OFDM 16QAM Outer Full	21.37	19.37	0.0865
376500	15KHZ 376500 DFT-s-OFDM 64QAM Edge 1RB Left	20.66	18.66	0.0735
376500	15KHZ 376500 DFT-s-OFDM 64QAM Edge 1RB Right	20.72	18.72	0.0745
376500	15KHZ 376500 DFT-s-OFDM 64QAM Outer Full	20.9	18.90	0.0776
376500	15KHZ 376500 DFT-s-OFDM 256QAM Edge 1RB Left	18.25	16.25	0.0422
376500	15KHZ 376500 DFT-s-OFDM 256QAM Edge 1RB Right	18.29	16.29	0.0426
376500	15KHZ 376500 DFT-s-OFDM 256QAM Outer Full	18.86	16.86	0.0485
376500	15KHZ 376500 CP-OFDM QPSK Inner Full	21.54	19.54	0.0899
376500	15KHZ 376500 CP-OFDM QPSK Edge 1RB Left	20.6	18.60	0.0724
376500	15KHZ 376500 CP-OFDM QPSK Edge 1RB Right	20.65	18.65	0.0733
376500	15KHZ 376500 CP-OFDM QPSK Outer Full	20.33	18.33	0.0681
376500	15KHZ 376500 CP-OFDM 16QAM Inner Full	21.46	19.46	0.0883
376500	15KHZ 376500 CP-OFDM 16QAM Edge 1RB Left	20.35	18.35	0.0684
376500	15KHZ 376500 CP-OFDM 16QAM Edge 1RB Right	20.42	18.42	0.0695
376500	15KHZ 376500 CP-OFDM 16QAM Outer Full	20.47	18.47	0.0703
376500	15KHZ 376500 CP-OFDM 64QAM Edge 1RB Left	19.48	17.48	0.0560
376500	15KHZ 376500 CP-OFDM 64QAM Edge 1RB Right	19.51	17.51	0.0564
376500	15KHZ 376500 CP-OFDM 64QAM Outer Full	19.84	17.84	0.0608
376500	15KHZ 376500 CP-OFDM 256QAM Edge 1RB Left	16.12	14.12	0.0258
376500	15KHZ 376500 CP-OFDM 256QAM Edge 1RB Right	16.2	14.20	0.0263
376500	15KHZ 376500 CP-OFDM 256QAM Outer Full	16.97	14.97	0.0314
382000	15KHZ 382000 DFT-s-OFDM P1/2 BPSK Inner 1RB Right	23.58	21.58	0.1439
382000	15KHZ 382000 DFT-s-OFDM P1/2 BPSK Inner 1RB Left	23.43	21.43	0.1390
382000	15KHZ 382000 DFT-s-OFDM P1/2 BPSK Inner Full	23.43	21.43	0.1390
382000	15KHZ 382000 DFT-s-OFDM QPSK Inner 1RB Right	23.37	21.37	0.1371
382000	15KHZ 382000 DFT-s-OFDM QPSK Inner 1RB Left	23.31	21.31	0.1352
382000	15KHZ 382000 DFT-s-OFDM QPSK Inner Full	23.45	21.45	0.1396
382000	15KHZ 382000 DFT-s-OFDM P1/2 BPSK Inner Full	23.6	21.60	0.1445
382000	15KHZ 382000 DFT-s-OFDM P1/2 BPSK Edge 1RB Left	22.81	20.81	0.1205
382000	15KHZ 382000 DFT-s-OFDM P1/2 BPSK Edge 1RB Right	22.98	20.98	0.1253
382000	15KHZ 382000 DFT-s-OFDM P1/2 BPSK Outer Full	22.94	20.94	0.1242
382000	15KHZ 382000 DFT-s-OFDM P1/2 BPSK Inner Full	23.38	21.38	0.1374
382000	15KHZ 382000 DFT-s-OFDM P1/2 BPSK Edge 1RB Left	22.84	20.84	0.1213
382000	15KHZ 382000 DFT-s-OFDM P1/2 BPSK Edge 1RB Right	22.93	20.93	0.1239
382000	15KHZ 382000 DFT-s-OFDM P1/2 BPSK Outer Full	22.93	20.93	0.1239
382000	15KHZ 382000 DFT-s-OFDM QPSK Inner Full	23.46	21.46	0.1400
382000	15KHZ 382000 DFT-s-OFDM QPSK Edge 1RB Left	22.45	20.45	0.1109
382000	15KHZ 382000 DFT-s-OFDM QPSK Edge 1RB Right	22.44	20.44	0.1107
382000	15KHZ 382000 DFT-s-OFDM QPSK Outer Full	22.36	20.36	0.1086
382000	15KHZ 382000 DFT-s-OFDM 16QAM Inner Full	22.32	20.32	0.1076
382000	15KHZ 382000 DFT-s-OFDM 16QAM Edge 1RB Left	21.4	19.40	0.0871
382000	15KHZ 382000 DFT-s-OFDM 16QAM Edge 1RB Right	21.35	19.35	0.0861
382000	15KHZ 382000 DFT-s-OFDM 16QAM Outer Full	21.49	19.49	0.0889
382000	15KHZ 382000 DFT-s-OFDM 64QAM Edge 1RB Left	20.66	18.66	0.0735
382000	15KHZ 382000 DFT-s-OFDM 64QAM Edge 1RB Right	20.77	18.77	0.0753
382000	15KHZ 382000 DFT-s-OFDM 64QAM Outer Full	20.88	18.88	0.0773
382000	15KHZ 382000 DFT-s-OFDM 256QAM Edge 1RB Left	18.25	16.25	0.0422
382000	15KHZ 382000 DFT-s-OFDM 256QAM Edge 1RB Right	18.36	16.36	0.0433
382000	15KHZ 382000 DFT-s-OFDM 256QAM Outer Full	18.85	16.85	0.0484
382000	15KHZ 382000 CP-OFDM QPSK Inner Full	21.51	19.51	0.0893
382000	15KHZ 382000 CP-OFDM QPSK Edge 1RB Left	20.75	18.75	0.0750
382000	15KHZ 382000 CP-OFDM QPSK Edge 1RB Right	20.71	18.71	0.0743
382000	15KHZ 382000 CP-OFDM QPSK Outer Full	20.39	18.39	0.0690
382000	15KHZ 382000 CP-OFDM 16QAM Inner Full	21.12	19.12	0.0817
382000	15KHZ 382000 CP-OFDM 16QAM Edge 1RB Left	20.52	18.52	0.0711
382000	15KHZ 382000 CP-OFDM 16QAM Edge 1RB Right	20.5	18.50	0.0708
382000	15KHZ 382000 CP-OFDM 16QAM Outer Full	20.43	18.43	0.0697
382000	15KHZ 382000 CP-OFDM 64QAM Edge 1RB Left	19.72	17.72	0.0592
382000	15KHZ 382000 CP-OFDM 64QAM Edge 1RB Right	19.65	17.65	0.0582
382000	15KHZ 382000 CP-OFDM 64QAM Outer Full	19.91	17.91	0.0618
382000	15KHZ 382000 CP-OFDM 256QAM Edge 1RB Left	16.13	14.13	0.0259
382000	15KHZ 382000 CP-OFDM 256QAM Edge 1RB Right	16.33	14.33	0.0271
382000	15KHZ 382000 CP-OFDM 256QAM Outer Full	16.97	14.97	0.0314

5G NR
n25-
15MHZ

Channel	TestItem	MeasuredValue	EIRP power (dbm)	EIRP power (W)
371500	15MHZ 15KHZ 371500 DFT-s-OFDM P1/2 BPSK Inner 1RB Right	23.7	21.70	0.1479
371500	15MHZ 15KHZ 371500 DFT-s-OFDM P1/2 BPSK Inner 1RB Left	23.58	21.58	0.1439
371500	15MHZ 15KHZ 371500 DFT-s-OFDM P1/2 BPSK Inner Full	23.69	21.69	0.1476
371500	15MHZ 15KHZ 371500 DFT-s-OFDM QPSK Inner 1RB Right	23.66	21.66	0.1466
371500	15MHZ 15KHZ 371500 DFT-s-OFDM QPSK Inner 1RB Left	23.55	21.55	0.1429
371500	15MHZ 15KHZ 371500 DFT-s-OFDM QPSK Inner Full	23.6	21.60	0.1445
371500	15MHZ 15KHZ 371500 DFT-s-OFDM P1/2 BPSK Inner Full	23.65	21.65	0.1462
371500	15MHZ 15KHZ 371500 DFT-s-OFDM P1/2 BPSK Edge 1RB Left	23.08	21.08	0.1282
371500	15MHZ 15KHZ 371500 DFT-s-OFDM P1/2 BPSK Edge 1RB Right	23.08	21.08	0.1282
371500	15MHZ 15KHZ 371500 DFT-s-OFDM P1/2 BPSK Outer Full	23.23	21.23	0.1327
371500	15MHZ 15KHZ 371500 DFT-s-OFDM P1/2 BPSK Inner Full	23.56	21.56	0.1432
371500	15MHZ 15KHZ 371500 DFT-s-OFDM P1/2 BPSK Edge 1RB Left	23.05	21.05	0.1274
371500	15MHZ 15KHZ 371500 DFT-s-OFDM P1/2 BPSK Edge 1RB Right	23.07	21.07	0.1279
371500	15MHZ 15KHZ 371500 DFT-s-OFDM QPSK Outer Full	23.12	21.12	0.1294
371500	15MHZ 15KHZ 371500 DFT-s-OFDM QPSK Inner Full	23.62	21.62	0.1452
371500	15MHZ 15KHZ 371500 DFT-s-OFDM QPSK Edge 1RB Left	22.56	20.56	0.1138
371500	15MHZ 15KHZ 371500 DFT-s-OFDM QPSK Edge 1RB Right	22.57	20.57	0.1140
371500	15MHZ 15KHZ 371500 DFT-s-OFDM QPSK Outer Full	22.55	20.55	0.1135
371500	15MHZ 15KHZ 371500 DFT-s-OFDM 16QAM Inner Full	22.65	20.65	0.1161
371500	15MHZ 15KHZ 371500 DFT-s-OFDM 16QAM Edge 1RB Left	21.61	19.61	0.0914
371500	15MHZ 15KHZ 371500 DFT-s-OFDM 16QAM Edge 1RB Right	21.51	19.51	0.0893
371500	15MHZ 15KHZ 371500 DFT-s-OFDM 16QAM Outer Full	21.49	19.49	0.0889
371500	15MHZ 15KHZ 371500 DFT-s-OFDM 64QAM Edge 1RB Left	20.96	18.96	0.0787
371500	15MHZ 15KHZ 371500 DFT-s-OFDM 64QAM Edge 1RB Right	20.98	18.98	0.0791
371500	15MHZ 15KHZ 371500 DFT-s-OFDM 64QAM Outer Full	21.04	19.04	0.0802
371500	15MHZ 15KHZ 371500 DFT-s-OFDM 256QAM Edge 1RB Left	18.52	16.52	0.0449
371500	15MHZ 15KHZ 371500 DFT-s-OFDM 256QAM Edge 1RB Right	18.59	16.59	0.0456
371500	15MHZ 15KHZ 371500 DFT-s-OFDM 256QAM Outer Full	19.04	17.04	0.0506
371500	15MHZ 15KHZ 371500 CP-OFDM QPSK Inner Full	22.11	20.11	0.1026
371500	15MHZ 15KHZ 371500 CP-OFDM QPSK Edge 1RB Left	20.82	18.82	0.0762
371500	15MHZ 15KHZ 371500 CP-OFDM QPSK Edge 1RB Right	20.81	18.81	0.0760
371500	15MHZ 15KHZ 371500 CP-OFDM QPSK Outer Full	20.62	18.62	0.0728
371500	15MHZ 15KHZ 371500 CP-OFDM 16QAM Inner Full	21.72	19.72	0.0938
371500	15MHZ 15KHZ 371500 CP-OFDM 16QAM Edge 1RB Left	20.7	18.70	0.0741
371500	15MHZ 15KHZ 371500 CP-OFDM 16QAM Edge 1RB Right	20.69	18.69	0.0740
371500	15MHZ 15KHZ 371500 CP-OFDM 16QAM Outer Full	20.63	18.63	0.0729
371500	15MHZ 15KHZ 371500 CP-OFDM 64QAM Edge 1RB Left	19.84	17.84	0.0608
371500	15MHZ 15KHZ 371500 CP-OFDM 64QAM Edge 1RB Right	19.86	17.86	0.0611
371500	15MHZ 15KHZ 371500 CP-OFDM 64QAM Outer Full	20.24	18.24	0.0667
371500	15MHZ 15KHZ 371500 CP-OFDM 256QAM Edge 1RB Left	18.48	16.48	0.0281
371500	15MHZ 15KHZ 371500 CP-OFDM 256QAM Edge 1RB Right	16.51	14.51	0.0282
371500	15MHZ 15KHZ 371500 CP-OFDM 256QAM Outer Full	17.1	15.10	0.0324
376500	376500 DFT-s-OFDM P1/2 BPSK Inner 1RB Right	23.44	21.44	0.1393
376500	376500 DFT-s-OFDM P1/2 BPSK Inner 1RB Left	23.66	21.66	0.1466
376500	376500 DFT-s-OFDM P1/2 BPSK Inner Full	23.59	21.59	0.1442
376500	376500 DFT-s-OFDM QPSK Inner 1RB Right	23.4	21.40	0.1380
376500	376500 DFT-s-OFDM QPSK Inner 1RB Left	23.39	21.39	0.1377
376500	376500 DFT-s-OFDM QPSK Inner Full	23.53	21.53	0.1422
376500	15MHZ 15KHZ 376500 DFT-s-OFDM P1/2 BPSK Inner Full	23.51	21.51	0.1416
376500	15MHZ 15KHZ 376500 DFT-s-OFDM P1/2 BPSK Edge 1RB Left	23.03	21.03	0.1268
376500	15MHZ 15KHZ 376500 DFT-s-OFDM P1/2 BPSK Edge 1RB Right	22.98	20.98	0.1253
376500	15MHZ 15KHZ 376500 DFT-s-OFDM P1/2 BPSK Outer Full	23	21.00	0.1259
376500	15MHZ 15KHZ 376500 DFT-s-OFDM P1/2 BPSK Inner Full	23.58	21.58	0.1439
376500	15MHZ 15KHZ 376500 DFT-s-OFDM P1/2 BPSK Edge 1RB Left	22.96	20.96	0.1247
376500	15MHZ 15KHZ 376500 DFT-s-OFDM P1/2 BPSK Edge 1RB Right	22.94	20.94	0.1242
376500	15MHZ 15KHZ 376500 DFT-s-OFDM P1/2 BPSK Outer Full	22.97	20.97	0.1250
376500	15MHZ 15KHZ 376500 DFT-s-OFDM QPSK Inner Full	23.43	21.43	0.1390
376500	15MHZ 15KHZ 376500 DFT-s-OFDM QPSK Edge 1RB Left	22.4	20.40	0.1096
376500	15MHZ 15KHZ 376500 DFT-s-OFDM QPSK Edge 1RB Right	22.31	20.31	0.1074
376500	15MHZ 15KHZ 376500 DFT-s-OFDM QPSK Outer Full	22.51	20.51	0.1125
376500	15MHZ 15KHZ 376500 DFT-s-OFDM 16QAM Inner Full	22.47	20.47	0.1114
376500	15MHZ 15KHZ 376500 DFT-s-OFDM 16QAM Edge 1RB Left	21.36	19.36	0.0863
376500	15MHZ 15KHZ 376500 DFT-s-OFDM 16QAM Edge 1RB Right	21.39	19.39	0.0869
376500	15MHZ 15KHZ 376500 DFT-s-OFDM 16QAM Outer Full	21.53	19.53	0.0897
376500	15MHZ 15KHZ 376500 DFT-s-OFDM 64QAM Edge 1RB Left	20.84	18.84	0.0766
376500	15MHZ 15KHZ 376500 DFT-s-OFDM 64QAM Edge 1RB Right	20.87	18.87	0.0771
376500	15MHZ 15KHZ 376500 DFT-s-OFDM 64QAM Outer Full	20.99	18.99	0.0793
376500	15MHZ 15KHZ 376500 DFT-s-OFDM 256QAM Edge 1RB Left	18.35	16.35	0.0432
376500	15MHZ 15KHZ 376500 DFT-s-OFDM 256QAM Edge 1RB Right	18.35	16.35	0.0432
376500	15MHZ 15KHZ 376500 DFT-s-OFDM 256QAM Outer Full	18.91	16.91	0.0491
376500	15MHZ 15KHZ 376500 CP-OFDM QPSK Inner Full	21.49	19.49	0.0889
376500	15MHZ 15KHZ 376500 CP-OFDM QPSK Edge 1RB Left	20.68	18.68	0.0738
376500	15MHZ 15KHZ 376500 CP-OFDM QPSK Edge 1RB Right	20.69	18.69	0.0740
376500	15MHZ 15KHZ 376500 CP-OFDM QPSK Outer Full	20.47	18.47	0.0703
376500	15MHZ 15KHZ 376500 CP-OFDM 16QAM Inner Full	21.58	19.58	0.0908
376500	15MHZ 15KHZ 376500 CP-OFDM 16QAM Edge 1RB Left	20.54	18.54	0.0714
376500	15MHZ 15KHZ 376500 CP-OFDM 16QAM Edge 1RB Right	20.53	18.53	0.0713
376500	15MHZ 15KHZ 376500 CP-OFDM 16QAM Outer Full	20.47	18.47	0.0703
376500	15MHZ 15KHZ 376500 CP-OFDM 64QAM Edge 1RB Left	19.69	17.69	0.0587
376500	15MHZ 15KHZ 376500 CP-OFDM 64QAM Edge 1RB Right	19.62	17.62	0.0578
376500	15MHZ 15KHZ 376500 CP-OFDM 64QAM Outer Full	20.08	18.08	0.0643
376500	15MHZ 15KHZ 376500 CP-OFDM 256QAM Edge 1RB Left	16.4	14.40	0.0275
376500	15MHZ 15KHZ 376500 CP-OFDM 256QAM Edge 1RB Right	16.31	14.31	0.0270
376500	15MHZ 15KHZ 376500 CP-OFDM 256QAM Outer Full	16.95	14.95	0.0313
381500	381500 DFT-s-OFDM P1/2 BPSK Inner 1RB Right	23.5	21.50	0.1413
381500	381500 DFT-s-OFDM P1/2 BPSK Inner 1RB Left	23.57	21.57	0.1435
381500	381500 DFT-s-OFDM P1/2 BPSK Inner Full	23.48	21.48	0.1406
381500	381500 DFT-s-OFDM QPSK Inner 1RB Right	23.55	21.55	0.1429
381500	381500 DFT-s-OFDM QPSK Inner 1RB Left	23.47	21.47	0.1403
381500	381500 DFT-s-OFDM QPSK Inner Full	23.52	21.52	0.1419
381500	15MHZ 15KHZ 381500 DFT-s-OFDM P1/2 BPSK Inner Full	23.51	21.51	0.1416
381500	15MHZ 15KHZ 381500 DFT-s-OFDM P1/2 BPSK Edge 1RB Left	22.92	20.92	0.1236
381500	15MHZ 15KHZ 381500 DFT-s-OFDM P1/2 BPSK Edge 1RB Right	22.94	20.94	0.1242
381500	15MHZ 15KHZ 381500 DFT-s-OFDM P1/2 BPSK Outer Full	23.04	21.04	0.1271
381500	15MHZ 15KHZ 381500 DFT-s-OFDM P1/2 BPSK Inner Full	23.54	21.54	0.1426
381500	15MHZ 15KHZ 381500 DFT-s-OFDM P1/2 BPSK Edge 1RB Left	23	21.00	0.1259
381500	15MHZ 15KHZ 381500 DFT-s-OFDM P1/2 BPSK Edge 1RB Right	23	21.00	0.1259
381500	15MHZ 15KHZ 381500 DFT-s-OFDM P1/2 BPSK Outer Full	23.05	21.05	0.1274
381500	15MHZ 15KHZ 381500 DFT-s-OFDM QPSK Inner Full	23.46	21.46	0.1400
381500	15MHZ 15KHZ 381500 DFT-s-OFDM QPSK Edge 1RB Left	22.31	20.31	0.1074
381500	15MHZ 15KHZ 381500 DFT-s-OFDM QPSK Edge 1RB Right	21.85	19.85	0.0966
381500	15MHZ 15KHZ 381500 DFT-s-OFDM QPSK Outer Full	22.52	20.52	0.1127
381500	15MHZ 15KHZ 381500 DFT-s-OFDM 16QAM Inner Full	22.51	20.51	0.1125
381500	15MHZ 15KHZ 381500 DFT-s-OFDM 16QAM Edge 1RB Left	21.38	19.38	0.0867
381500	15MHZ 15KHZ 381500 DFT-s-OFDM 16QAM Edge 1RB Right	20.94	18.94	0.0783
381500	15MHZ 15KHZ 381500 DFT-s-OFDM 16QAM Outer Full	21.5	19.50	0.0891
381500	15MHZ 15KHZ 381500 DFT-s-OFDM 64QAM Edge 1RB Left	20.73	18.73	0.0746
381500	15MHZ 15KHZ 381500 DFT-s-OFDM 64QAM Edge 1RB Right	20.28	18.28	0.0673
381500	15MHZ 15KHZ 381500 DFT-s-OFDM 64QAM Outer Full	21.05	19.05	0.0804
381500	15MHZ 15KHZ 381500 DFT-s-OFDM 256QAM Edge 1RB Left	18.35	16.35	0.0432
381500	15MHZ 15KHZ 381500 DFT-s-OFDM 256QAM Edge 1RB Right	18.45	16.45	0.0442
381500	15MHZ 15KHZ 381500 DFT-s-OFDM 256QAM Outer Full	18.95	16.95	0.0495
381500	15MHZ 15KHZ 381500 CP-OFDM QPSK Inner Full	21.51	19.51	0.0893
381500	15MHZ 15KHZ 381500 CP-OFDM QPSK Edge 1RB Left	20.76	18.76	0.0752
381500	15MHZ 15KHZ 381500 CP-OFDM QPSK Edge 1RB Right	20.5	18.50	0.0708
381500	15MHZ 15KHZ 381500 CP-OFDM QPSK Outer Full	20.45	18.45	0.0700
381500	15MHZ 15KHZ 381500 CP-OFDM 16QAM Inner Full	21.5	19.50	0.0891
381500	15MHZ 15KHZ 381500 CP-OFDM 16QAM Edge 1RB Left	20.55	18.55	0.0716
381500	15MHZ 15KHZ 381500 CP-OFDM 16QAM Edge 1RB Right	20.56	18.56	0.0718
381500	15MHZ 15KHZ 381500 CP-OFDM 16QAM Outer Full	20.51	18.51	0.0710
381500	15MHZ 15KHZ 381500 CP-OFDM 64QAM Edge 1RB Left	19.68	17.68	0.0586
381500	15MHZ 15KHZ 381500 CP-OFDM 64QAM Edge 1RB Right	19.74	17.74	0.0594
381500	15MHZ 15KHZ 381500 CP-OFDM 64QAM Outer Full	20.06	18.06	0.0640
381500	15MHZ 15KHZ 381500 CP-OFDM 256QAM Edge 1RB Left	16.31	14.31	0.0270
381500	15MHZ 15KHZ 381500 CP-OFDM 256QAM Edge 1RB Right	16.32	14.32	0.0270
381500	15MHZ 15KHZ 381500 CP-OFDM 256QAM Outer Full	16.92	14.92	0.0310

5G NR
n25-
20MHZ

Channel	TestItem	MeasuredValue	EIRP power (dbm)	EIRP power (W)
372000	15KHZ 372000 DFT-s-OFDM P1/2 BPSK Inner 1RB Right	23.5	21.50	0.1413
372000	15KHZ 372000 DFT-s-OFDM P1/2 BPSK Inner 1RB Left	23.88	21.88	0.1542
372000	15KHZ 372000 DFT-s-OFDM P1/2 BPSK Inner Full	23.43	21.43	0.1390
372000	15KHZ 372000 DFT-s-OFDM QPSK Inner 1RB Right	23.55	21.55	0.1429
372000	15KHZ 372000 DFT-s-OFDM QPSK Inner 1RB Left	23.35	21.35	0.1365
372000	15KHZ 372000 DFT-s-OFDM QPSK Inner Full	23.56	21.56	0.1432
372000	15KHZ 372000 DFT-s-OFDM P1/2 BPSK Inner Full	23.52	21.52	0.1419
372000	15KHZ 372000 DFT-s-OFDM P1/2 BPSK Edge 1RB Left	22.89	20.89	0.1227
372000	15KHZ 372000 DFT-s-OFDM P1/2 BPSK Edge 1RB Right	23.08	21.08	0.1282
372000	15KHZ 372000 DFT-s-OFDM P1/2 BPSK Outer Full	22.87	20.87	0.1222
372000	15KHZ 372000 DFT-s-OFDM P1/2 BPSK Inner Full	23.41	21.41	0.1384
372000	15KHZ 372000 DFT-s-OFDM P1/2 BPSK Edge 1RB Left	22.91	20.91	0.1233
372000	15KHZ 372000 DFT-s-OFDM P1/2 BPSK Edge 1RB Right	23.09	21.09	0.1285
372000	15KHZ 372000 DFT-s-OFDM P1/2 BPSK Outer Full	22.86	20.86	0.1219
372000	15KHZ 372000 DFT-s-OFDM QPSK Inner Full	23.55	21.55	0.1429
372000	15KHZ 372000 DFT-s-OFDM QPSK Edge 1RB Left	22.34	20.34	0.1081
372000	15KHZ 372000 DFT-s-OFDM QPSK Edge 1RB Right	22.57	20.57	0.1140
372000	15KHZ 372000 DFT-s-OFDM QPSK Outer Full	22.49	20.49	0.1119
372000	15KHZ 372000 DFT-s-OFDM 16QAM Inner Full	22.38	20.38	0.1091
372000	15KHZ 372000 DFT-s-OFDM 16QAM Edge 1RB Left	21.29	19.29	0.0849
372000	15KHZ 372000 DFT-s-OFDM 16QAM Edge 1RB Right	21.51	19.51	0.0893
372000	15KHZ 372000 DFT-s-OFDM 16QAM Outer Full	21.36	19.36	0.0863
372000	15KHZ 372000 DFT-s-OFDM 64QAM Edge 1RB Left	20.64	18.64	0.0731
372000	15KHZ 372000 DFT-s-OFDM 64QAM Edge 1RB Right	20.88	18.88	0.0773
372000	15KHZ 372000 DFT-s-OFDM 64QAM Outer Full	20.96	18.96	0.0787
372000	15KHZ 372000 DFT-s-OFDM 256QAM Edge 1RB Left	18.25	16.25	0.0422
372000	15KHZ 372000 DFT-s-OFDM 256QAM Edge 1RB Right	18.39	16.39	0.0436
372000	15KHZ 372000 DFT-s-OFDM 256QAM Outer Full	18.93	16.93	0.0493
372000	15KHZ 372000 CP-OFDM QPSK Inner Full	21.52	19.52	0.0895
372000	15KHZ 372000 CP-OFDM QPSK Edge 1RB Left	20.6	18.60	0.0724
372000	15KHZ 372000 CP-OFDM QPSK Edge 1RB Right	20.74	18.74	0.0748
372000	15KHZ 372000 CP-OFDM QPSK Outer Full	20.43	18.43	0.0697
372000	15KHZ 372000 CP-OFDM 16QAM Inner Full	21.45	19.45	0.0881
372000	15KHZ 372000 CP-OFDM 16QAM Edge 1RB Left	20.46	18.46	0.0701
372000	15KHZ 372000 CP-OFDM 16QAM Edge 1RB Right	20.5	18.50	0.0708
372000	15KHZ 372000 CP-OFDM 16QAM Outer Full	20.42	18.42	0.0695
372000	15KHZ 372000 CP-OFDM 64QAM Edge 1RB Left	19.6	17.60	0.0575
372000	15KHZ 372000 CP-OFDM 64QAM Edge 1RB Right	19.81	17.81	0.0604
372000	15KHZ 372000 CP-OFDM 64QAM Outer Full	19.93	17.93	0.0621
372000	15KHZ 372000 CP-OFDM 256QAM Edge 1RB Left	16.16	14.16	0.0261
372000	15KHZ 372000 CP-OFDM 256QAM Edge 1RB Right	16.4	14.40	0.0275
372000	15KHZ 372000 CP-OFDM 256QAM Outer Full	16.93	14.93	0.0311
376500	15KHZ 376500 DFT-s-OFDM P1/2 BPSK Inner 1RB Right	23.6	21.60	0.1445
376500	15KHZ 376500 DFT-s-OFDM P1/2 BPSK Inner 1RB Left	23.63	21.63	0.1455
376500	15KHZ 376500 DFT-s-OFDM P1/2 BPSK Inner Full	23.62	21.62	0.1452
376500	15KHZ 376500 DFT-s-OFDM QPSK Inner 1RB Right	23.51	21.51	0.1416
376500	15KHZ 376500 DFT-s-OFDM QPSK Inner 1RB Left	23.63	21.63	0.1455
376500	15KHZ 376500 DFT-s-OFDM QPSK Inner Full	23.62	21.62	0.1452
376500	15KHZ 376500 DFT-s-OFDM P1/2 BPSK Inner Full	23.66	21.66	0.1466
376500	15KHZ 376500 DFT-s-OFDM P1/2 BPSK Edge 1RB Left	23.11	21.11	0.1291
376500	15KHZ 376500 DFT-s-OFDM P1/2 BPSK Edge 1RB Right	23.13	21.13	0.1297
376500	15KHZ 376500 DFT-s-OFDM P1/2 BPSK Outer Full	23.06	21.06	0.1276
376500	15KHZ 376500 DFT-s-OFDM P1/2 BPSK Inner Full	23.6	21.60	0.1445
376500	15KHZ 376500 DFT-s-OFDM P1/2 BPSK Edge 1RB Left	23.09	21.09	0.1285
376500	15KHZ 376500 DFT-s-OFDM P1/2 BPSK Edge 1RB Right	23.11	21.11	0.1291
376500	15KHZ 376500 DFT-s-OFDM P1/2 BPSK Outer Full	23.14	21.14	0.1300
376500	15KHZ 376500 DFT-s-OFDM QPSK Inner Full	23.66	21.66	0.1466
376500	15KHZ 376500 DFT-s-OFDM QPSK Edge 1RB Left	22.57	20.57	0.1140
376500	15KHZ 376500 DFT-s-OFDM QPSK Edge 1RB Right	22.66	20.66	0.1164
376500	15KHZ 376500 DFT-s-OFDM QPSK Outer Full	22.54	20.54	0.1132
376500	15KHZ 376500 DFT-s-OFDM 16QAM Inner Full	22.64	20.64	0.1159
376500	15KHZ 376500 DFT-s-OFDM 16QAM Edge 1RB Left	21.5	19.50	0.0891
376500	15KHZ 376500 DFT-s-OFDM 16QAM Edge 1RB Right	21.56	19.56	0.0904
376500	15KHZ 376500 DFT-s-OFDM 16QAM Outer Full	21.61	19.61	0.0914
376500	15KHZ 376500 DFT-s-OFDM 64QAM Edge 1RB Left	20.94	18.94	0.0783
376500	15KHZ 376500 DFT-s-OFDM 64QAM Edge 1RB Right	20.98	18.98	0.0791
376500	15KHZ 376500 DFT-s-OFDM 64QAM Outer Full	21.11	19.11	0.0815
376500	15KHZ 376500 DFT-s-OFDM 256QAM Edge 1RB Left	18.56	16.56	0.0453
376500	15KHZ 376500 DFT-s-OFDM 256QAM Edge 1RB Right	18.46	16.46	0.0443
376500	15KHZ 376500 DFT-s-OFDM 256QAM Outer Full	19.13	17.13	0.0516
376500	15KHZ 376500 CP-OFDM QPSK Inner Full	22.12	20.12	0.1028
376500	15KHZ 376500 CP-OFDM QPSK Edge 1RB Left	20.85	18.85	0.0767
376500	15KHZ 376500 CP-OFDM QPSK Edge 1RB Right	20.58	18.58	0.0721
376500	15KHZ 376500 CP-OFDM QPSK Outer Full	20.59	18.59	0.0723
376500	15KHZ 376500 CP-OFDM 16QAM Inner Full	21.61	19.61	0.0914
376500	15KHZ 376500 CP-OFDM 16QAM Edge 1RB Left	20.74	18.74	0.0748
376500	15KHZ 376500 CP-OFDM 16QAM Edge 1RB Right	20.6	18.60	0.0724
376500	15KHZ 376500 CP-OFDM 16QAM Outer Full	20.57	18.57	0.0719
376500	15KHZ 376500 CP-OFDM 64QAM Edge 1RB Left	19.81	17.81	0.0604
376500	15KHZ 376500 CP-OFDM 64QAM Edge 1RB Right	19.84	17.84	0.0608
376500	15KHZ 376500 CP-OFDM 64QAM Outer Full	20.17	18.17	0.0656
376500	15KHZ 376500 CP-OFDM 256QAM Edge 1RB Left	16.44	14.44	0.0278
376500	15KHZ 376500 CP-OFDM 256QAM Edge 1RB Right	16.5	14.50	0.0282
376500	15KHZ 376500 CP-OFDM 256QAM Outer Full	17.07	15.07	0.0321
381000	15KHZ 381000 DFT-s-OFDM P1/2 BPSK Inner 1RB Right	23.39	21.39	0.1377
381000	15KHZ 381000 DFT-s-OFDM P1/2 BPSK Inner 1RB Left	23.63	21.63	0.1455
381000	15KHZ 381000 DFT-s-OFDM P1/2 BPSK Inner Full	23.78	21.78	0.1507
381000	15KHZ 381000 DFT-s-OFDM QPSK Inner 1RB Right	23.5	21.50	0.1413
381000	15KHZ 381000 DFT-s-OFDM QPSK Inner 1RB Left	23.71	21.71	0.1483
381000	15KHZ 381000 DFT-s-OFDM QPSK Inner Full	23.67	21.67	0.1469
381000	15KHZ 381000 DFT-s-OFDM P1/2 BPSK Inner Full	23.72	21.72	0.1486
381000	15KHZ 381000 DFT-s-OFDM P1/2 BPSK Edge 1RB Left	23.23	21.23	0.1327
381000	15KHZ 381000 DFT-s-OFDM P1/2 BPSK Edge 1RB Right	22.96	20.96	0.1247
381000	15KHZ 381000 DFT-s-OFDM P1/2 BPSK Outer Full	23.12	21.12	0.1294
381000	15KHZ 381000 DFT-s-OFDM P1/2 BPSK Inner Full	23.75	21.75	0.1496
381000	15KHZ 381000 DFT-s-OFDM P1/2 BPSK Edge 1RB Left	23.08	21.08	0.1282
381000	15KHZ 381000 DFT-s-OFDM P1/2 BPSK Edge 1RB Right	22.93	20.93	0.1239
381000	15KHZ 381000 DFT-s-OFDM P1/2 BPSK Outer Full	23.12	21.12	0.1294
381000	15KHZ 381000 DFT-s-OFDM QPSK Inner Full	23.67	21.67	0.1469
381000	15KHZ 381000 DFT-s-OFDM QPSK Edge 1RB Left	22.58	20.58	0.1143
381000	15KHZ 381000 DFT-s-OFDM QPSK Edge 1RB Right	22.42	20.42	0.1102
381000	15KHZ 381000 DFT-s-OFDM QPSK Outer Full	22.63	20.63	0.1156
381000	15KHZ 381000 DFT-s-OFDM 16QAM Inner Full	22.53	20.53	0.1130
381000	15KHZ 381000 DFT-s-OFDM 16QAM Edge 1RB Left	21.57	19.57	0.0906
381000	15KHZ 381000 DFT-s-OFDM 16QAM Edge 1RB Right	21.36	19.36	0.0863
381000	15KHZ 381000 DFT-s-OFDM 16QAM Outer Full	21.67	19.67	0.0927
381000	15KHZ 381000 DFT-s-OFDM 64QAM Edge 1RB Left	21.08	19.08	0.0809
381000	15KHZ 381000 DFT-s-OFDM 64QAM Edge 1RB Right	20.78	18.78	0.0755
381000	15KHZ 381000 DFT-s-OFDM 64QAM Outer Full	21.16	19.16	0.0824
381000	15KHZ 381000 DFT-s-OFDM 256QAM Edge 1RB Left	18.63	16.63	0.0460
381000	15KHZ 381000 DFT-s-OFDM 256QAM Edge 1RB Right	18.3	16.30	0.0427
381000	15KHZ 381000 DFT-s-OFDM 256QAM Outer Full	19.12	17.12	0.0515
381000	15KHZ 381000 CP-OFDM QPSK Inner Full	22.07	20.07	0.1016
381000	15KHZ 381000 CP-OFDM QPSK Edge 1RB Left	20.88	18.88	0.0773
381000	15KHZ 381000 CP-OFDM QPSK Edge 1RB Right	20.47	18.47	0.0703
381000	15KHZ 381000 CP-OFDM QPSK Outer Full	20.46	18.46	0.0701
381000	15KHZ 381000 CP-OFDM 16QAM Inner Full	21.59	19.59	0.0910
381000	15KHZ 381000 CP-OFDM 16QAM Edge 1RB Left	20.77	18.77	0.0753
381000	15KHZ 381000 CP-OFDM 16QAM Edge 1RB Right	20.47	18.47	0.0703
381000	15KHZ 381000 CP-OFDM 16QAM Outer Full	20.55	18.55	0.0716
381000	15KHZ 381000 CP-OFDM 64QAM Edge 1RB Left	19.91	17.91	0.0618
381000	15KHZ 381000 CP-OFDM 64QAM Edge 1RB Right	19.72	17.72	0.0592
381000	15KHZ 381000 CP-OFDM 64QAM Outer Full	20.05	18.05	0.0638
381000	15KHZ 381000 CP-OFDM 256QAM Edge 1RB Left	16.55	14.55	0.0285
381000	15KHZ 381000 CP-OFDM 256QAM Edge 1RB Right	16.2	14.20	0.0263
381000	15KHZ 381000 CP-OFDM 256QAM Outer Full	17.09	15.09	0.0323

5G NR	Channel	TestItem	MeasuredValue	EIRP power (dbm)	EIRP power (W)
n66-5MHZ	342500	15KHZ 342500 DFT-s-OFDM PI/2 BPSK Inner IRB Right	23.14	21.14	0.1300
	342500	15KHZ 342500 DFT-s-OFDM PI/2 BPSK Inner IRB Left	23.18	21.18	0.1312
	342500	15KHZ 342500 DFT-s-OFDM PI/2 BPSK Inner Full	23.23	21.23	0.1327
	342500	15KHZ 342500 DFT-s-OFDM QPSK Inner IRB Right	23.06	21.06	0.1276
	342500	15KHZ 342500 DFT-s-OFDM QPSK Inner IRB Left	23.12	21.12	0.1294
	342500	15KHZ 342500 DFT-s-OFDM QPSK Inner Full	23.15	21.15	0.1303
	342500	15KHZ 342500 DFT-s-OFDM PI/2 BPSK Edge IRB Left	23.12	21.12	0.1294
	342500	15KHZ 342500 DFT-s-OFDM PI/2 BPSK Edge IRB Right	22.69	20.69	0.1172
	342500	15KHZ 342500 DFT-s-OFDM PI/2 BPSK Edge IRB Full	22.56	20.56	0.1138
	342500	15KHZ 342500 DFT-s-OFDM PI/2 BPSK Outer Full	22.53	20.53	0.1130
	342500	15KHZ 342500 DFT-s-OFDM PI/2 BPSK Inner Full	23.26	21.26	0.1337
	342500	15KHZ 342500 DFT-s-OFDM PI/2 BPSK Edge IRB Left	22.61	20.61	0.1151
	342500	15KHZ 342500 DFT-s-OFDM PI/2 BPSK Edge IRB Right	22.5	20.5	0.1122
	342500	15KHZ 342500 DFT-s-OFDM PI/2 BPSK Outer Full	22.6	20.6	0.1148
	342500	15KHZ 342500 DFT-s-OFDM QPSK Inner Full	23.17	21.17	0.1309
	342500	15KHZ 342500 DFT-s-OFDM QPSK Edge IRB Left	22.05	20.05	0.1012
	342500	15KHZ 342500 DFT-s-OFDM QPSK Edge IRB Right	21.96	19.96	0.0991
	342500	15KHZ 342500 DFT-s-OFDM QPSK Outer Full	22.06	20.06	0.1014
	342500	15KHZ 342500 DFT-s-OFDM 16QAM Inner Full	22.06	20.06	0.1014
	342500	15KHZ 342500 DFT-s-OFDM 16QAM Edge IRB Left	21.12	19.12	0.0817
	342500	15KHZ 342500 DFT-s-OFDM 16QAM Edge IRB Right	21.01	19.01	0.0796
	342500	15KHZ 342500 DFT-s-OFDM 16QAM Outer Full	21.12	19.12	0.0817
	342500	15KHZ 342500 DFT-s-OFDM 64QAM Edge IRB Left	20.46	18.46	0.0701
	342500	15KHZ 342500 DFT-s-OFDM 64QAM Edge IRB Right	20.35	18.35	0.0684
	342500	15KHZ 342500 DFT-s-OFDM 64QAM Outer Full	20.59	18.59	0.0723
	342500	15KHZ 342500 DFT-s-OFDM 256QAM Edge IRB Left	18.07	16.07	0.0405
	342500	15KHZ 342500 DFT-s-OFDM 256QAM Edge IRB Right	17.91	15.91	0.0390
	342500	15KHZ 342500 DFT-s-OFDM 256QAM Outer Full	18.58	16.58	0.0455
	342500	CP-OFDM QPSK Inner Full	21.13	19.13	0.0818
	342500	CP-OFDM QPSK Edge IRB Left	20.34	18.34	0.0682
	342500	CP-OFDM QPSK Edge IRB Right	20.19	18.19	0.0659
	342500	CP-OFDM QPSK Outer Full	20.04	18.04	0.0637
	342500	CP-OFDM 16QAM Inner Full	20.64	18.64	0.0731
	342500	CP-OFDM 16QAM Edge IRB Left	20.25	18.25	0.0668
	342500	CP-OFDM 16QAM Edge IRB Right	20.1	18.10	0.0646
	342500	CP-OFDM 16QAM Outer Full	20.2	18.20	0.0661
	342500	CP-OFDM 64QAM Edge IRB Left	19.47	17.47	0.0558
	342500	CP-OFDM 64QAM Edge IRB Right	19.31	17.31	0.0538
	342500	CP-OFDM 64QAM Outer Full	19.64	17.64	0.0561
	342500	CP-OFDM 256QAM Edge IRB Left	16.21	14.21	0.0264
342500	CP-OFDM 256QAM Edge IRB Right	16.04	14.04	0.0254	
342500	CP-OFDM 256QAM Outer Full	16.63	14.63	0.0290	
349000	15KHZ 349000 DFT-s-OFDM PI/2 BPSK Inner IRB Right	23.15	21.15	0.1303	
349000	15KHZ 349000 DFT-s-OFDM PI/2 BPSK Inner IRB Left	23.15	21.15	0.1303	
349000	15KHZ 349000 DFT-s-OFDM PI/2 BPSK Inner Full	23.15	21.15	0.1303	
349000	15KHZ 349000 DFT-s-OFDM QPSK Inner IRB Right	23.14	21.14	0.1300	
349000	15KHZ 349000 DFT-s-OFDM QPSK Inner IRB Left	23.19	21.19	0.1315	
349000	15KHZ 349000 DFT-s-OFDM QPSK Inner Full	23.15	21.15	0.1303	
349000	15KHZ 349000 DFT-s-OFDM PI/2 BPSK Inner Full	23.07	21.07	0.1279	
349000	15KHZ 349000 DFT-s-OFDM PI/2 BPSK Edge IRB Left	22.74	20.74	0.1186	
349000	15KHZ 349000 DFT-s-OFDM PI/2 BPSK Edge IRB Right	22.68	20.68	0.1169	
349000	15KHZ 349000 DFT-s-OFDM PI/2 BPSK Outer Full	22.56	20.56	0.1138	
349000	15KHZ 349000 DFT-s-OFDM PI/2 BPSK Inner Full	23.31	21.31	0.1352	
349000	15KHZ 349000 DFT-s-OFDM PI/2 BPSK Edge IRB Left	22.68	20.68	0.1169	
349000	15KHZ 349000 DFT-s-OFDM PI/2 BPSK Edge IRB Right	22.56	20.56	0.1138	
349000	15KHZ 349000 DFT-s-OFDM PI/2 BPSK Outer Full	22.68	20.68	0.1169	
349000	15KHZ 349000 DFT-s-OFDM QPSK Inner Full	23.16	21.16	0.1306	
349000	15KHZ 349000 DFT-s-OFDM QPSK Edge IRB Left	22.24	20.24	0.1057	
349000	15KHZ 349000 DFT-s-OFDM QPSK Edge IRB Right	22.09	20.09	0.1021	
349000	15KHZ 349000 DFT-s-OFDM QPSK Outer Full	22.08	20.08	0.1019	
349000	15KHZ 349000 DFT-s-OFDM 16QAM Inner Full	22.35	20.35	0.1084	
349000	15KHZ 349000 DFT-s-OFDM 16QAM Edge IRB Left	21.17	19.17	0.0826	
349000	15KHZ 349000 DFT-s-OFDM 16QAM Edge IRB Right	21.12	19.12	0.0817	
349000	15KHZ 349000 DFT-s-OFDM 16QAM Outer Full	21.18	19.18	0.0828	
349000	15KHZ 349000 DFT-s-OFDM 64QAM Edge IRB Left	20.69	18.69	0.0740	
349000	15KHZ 349000 DFT-s-OFDM 64QAM Edge IRB Right	20.4	18.40	0.0692	
349000	15KHZ 349000 DFT-s-OFDM 64QAM Outer Full	20.74	18.74	0.0748	
349000	15KHZ 349000 DFT-s-OFDM 256QAM Edge IRB Left	18.21	16.21	0.0418	
349000	15KHZ 349000 DFT-s-OFDM 256QAM Edge IRB Right	17.96	15.96	0.0394	
349000	15KHZ 349000 DFT-s-OFDM 256QAM Outer Full	18.74	16.74	0.0472	
349000	15KHZ 349000 CP-OFDM QPSK Inner Full	21.65	19.65	0.0923	
349000	15KHZ 349000 CP-OFDM QPSK Edge IRB Left	20.41	18.41	0.0693	
349000	15KHZ 349000 CP-OFDM QPSK Edge IRB Right	20.25	18.25	0.0668	
349000	15KHZ 349000 CP-OFDM QPSK Outer Full	20.11	18.11	0.0647	
349000	15KHZ 349000 CP-OFDM 16QAM Inner Full	20.76	18.76	0.0752	
349000	15KHZ 349000 CP-OFDM 16QAM Edge IRB Left	20.43	18.43	0.0697	
349000	15KHZ 349000 CP-OFDM 16QAM Edge IRB Right	20.23	18.23	0.0665	
349000	15KHZ 349000 CP-OFDM 16QAM Outer Full	20.4	18.40	0.0692	
349000	15KHZ 349000 CP-OFDM 64QAM Edge IRB Left	19.4	17.40	0.0550	
349000	15KHZ 349000 CP-OFDM 64QAM Edge IRB Right	19.43	17.43	0.0553	
349000	15KHZ 349000 CP-OFDM 64QAM Outer Full	19.7	17.70	0.0589	
349000	15KHZ 349000 CP-OFDM 256QAM Edge IRB Left	16.38	14.38	0.0274	
349000	15KHZ 349000 CP-OFDM 256QAM Edge IRB Right	16.01	14.01	0.0252	
349000	15KHZ 349000 CP-OFDM 256QAM Outer Full	16.69	14.69	0.0294	
355500	15KHZ 355500 DFT-s-OFDM PI/2 BPSK Inner IRB Right	23.06	21.06	0.1276	
355500	15KHZ 355500 DFT-s-OFDM PI/2 BPSK Inner IRB Left	23.12	21.12	0.1294	
355500	15KHZ 355500 DFT-s-OFDM PI/2 BPSK Inner Full	23.01	21.01	0.1262	
355500	15KHZ 355500 DFT-s-OFDM QPSK Inner IRB Right	22.97	20.97	0.1250	
355500	15KHZ 355500 DFT-s-OFDM QPSK Inner IRB Left	23.18	21.18	0.1312	
355500	15KHZ 355500 DFT-s-OFDM QPSK Inner Full	23.07	21.07	0.1279	
355500	15KHZ 355500 DFT-s-OFDM PI/2 BPSK Inner Full	23.02	21.02	0.1265	
355500	15KHZ 355500 DFT-s-OFDM PI/2 BPSK Edge IRB Left	22.68	20.68	0.1169	
355500	15KHZ 355500 DFT-s-OFDM PI/2 BPSK Edge IRB Right	22.45	20.45	0.1109	
355500	15KHZ 355500 DFT-s-OFDM PI/2 BPSK Outer Full	22.51	20.51	0.1125	
355500	15KHZ 355500 DFT-s-OFDM PI/2 BPSK Outer Full	22.97	20.97	0.1250	
355500	15KHZ 355500 DFT-s-OFDM PI/2 BPSK Edge IRB Left	22.61	20.61	0.1151	
355500	15KHZ 355500 DFT-s-OFDM PI/2 BPSK Edge IRB Right	22.48	20.48	0.1117	
355500	15KHZ 355500 DFT-s-OFDM PI/2 BPSK Outer Full	22.5	20.50	0.1122	
355500	15KHZ 355500 DFT-s-OFDM QPSK Inner Full	23.07	21.07	0.1279	
355500	15KHZ 355500 DFT-s-OFDM QPSK Edge IRB Left	22.13	20.13	0.1030	
355500	15KHZ 355500 DFT-s-OFDM QPSK Edge IRB Right	21.92	19.92	0.0982	
355500	15KHZ 355500 DFT-s-OFDM QPSK Outer Full	22	20.00	0.1000	
355500	15KHZ 355500 DFT-s-OFDM 16QAM Inner Full	22.19	20.19	0.1045	
355500	15KHZ 355500 DFT-s-OFDM 16QAM Edge IRB Left	21.11	19.11	0.0815	
355500	15KHZ 355500 DFT-s-OFDM 16QAM Edge IRB Right	20.93	18.93	0.0782	
355500	15KHZ 355500 DFT-s-OFDM 16QAM Outer Full	21.13	19.13	0.0818	
355500	15KHZ 355500 DFT-s-OFDM 64QAM Edge IRB Left	20.36	18.36	0.0685	
355500	15KHZ 355500 DFT-s-OFDM 64QAM Edge IRB Right	20.38	18.38	0.0689	
355500	15KHZ 355500 DFT-s-OFDM 64QAM Outer Full	20.58	18.58	0.0721	
355500	15KHZ 355500 DFT-s-OFDM 256QAM Edge IRB Left	17.94	15.94	0.0393	
355500	15KHZ 355500 DFT-s-OFDM 256QAM Edge IRB Right	17.91	15.91	0.0390	
355500	15KHZ 355500 DFT-s-OFDM 256QAM Outer Full	18.59	16.59	0.0455	
355500	15KHZ 355500 CP-OFDM QPSK Inner Full	21.5	19.50	0.0891	
355500	15KHZ 355500 CP-OFDM QPSK Edge IRB Left	20.2	18.20	0.0661	
355500	15KHZ 355500 CP-OFDM QPSK Edge IRB Right	20.03	18.03	0.0635	
355500	15KHZ 355500 CP-OFDM QPSK Outer Full	19.86	17.86	0.0611	
355500	15KHZ 355500 CP-OFDM 16QAM Inner Full	20.6	18.60	0.0724	
355500	15KHZ 355500 CP-OFDM 16QAM Edge IRB Left	20.16	18.16	0.0655	
355500	15KHZ 355500 CP-OFDM 16QAM Edge IRB Right	20.12	18.12	0.0649	
355500	15KHZ 355500 CP-OFDM 16QAM Outer Full	20.07	18.07	0.0641	
355500	15KHZ 355500 CP-OFDM 64QAM Edge IRB Left	19.42	17.42	0.0552	
355500	15KHZ 355500 CP-OFDM 64QAM Edge IRB Right	19.17	17.17	0.0521	
355500	15KHZ 355500 CP-OFDM 64QAM Outer Full	19.6	17.60	0.0575	
355500	15KHZ 355500 CP-OFDM 256QAM Edge IRB Left	15.95	13.95	0.0248	
355500	15KHZ 355500 CP-OFDM 256QAM Edge IRB Right	15.98	13.98	0.0250	
355500	15KHZ 355500 CP-OFDM 256QAM Outer Full	16.61	14.61	0.0289	

5G NR
n66-
10MHZ

Channel	TestItem	MeasuredValue	EIRP power (dbm)	EIRP power (dbm)
343000	15KHZ 343000 DFT-s-OFDM P1/2 BPSK Inner 1RB Right	23.1	21.10	0.1288
343000	15KHZ 343000 DFT-s-OFDM P1/2 BPSK Inner 1RB Left	23.06	21.06	0.1276
343000	15KHZ 343000 DFT-s-OFDM P1/2 BPSK Inner Full	23.27	21.27	0.1340
343000	15KHZ 343000 DFT-s-OFDM QPSK Inner 1RB Right	22.93	20.93	0.1239
343000	15KHZ 343000 DFT-s-OFDM QPSK Inner 1RB Left	23.03	21.03	0.1268
343000	15KHZ 343000 DFT-s-OFDM QPSK Inner Full	23.14	21.14	0.1300
343000	15KHZ 343000 DFT-s-OFDM P1/2 BPSK Inner Full	23.16	21.16	0.1306
343000	15KHZ 343000 DFT-s-OFDM P1/2 BPSK Edge 1RB Left	22.16	20.16	0.1038
343000	15KHZ 343000 DFT-s-OFDM P1/2 BPSK Edge 1RB Right	20.54	18.54	0.0714
343000	15KHZ 343000 DFT-s-OFDM P1/2 BPSK Outer Full	22.19	20.19	0.1045
343000	15KHZ 343000 DFT-s-OFDM P1/2 BPSK Inner Full	23.07	21.07	0.1279
343000	15KHZ 343000 DFT-s-OFDM P1/2 BPSK Edge 1RB Left	22.12	20.12	0.1028
343000	15KHZ 343000 DFT-s-OFDM P1/2 BPSK Edge 1RB Right	20.51	18.51	0.0710
343000	15KHZ 343000 DFT-s-OFDM P1/2 BPSK Outer Full	22.17	20.17	0.1040
343000	15KHZ 343000 DFT-s-OFDM QPSK Inner Full	22.99	20.99	0.1256
343000	15KHZ 343000 DFT-s-OFDM QPSK Edge 1RB Left	21.43	19.43	0.0877
343000	15KHZ 343000 DFT-s-OFDM QPSK Edge 1RB Right	20.01	18.01	0.0632
343000	15KHZ 343000 DFT-s-OFDM QPSK Outer Full	21.63	19.63	0.0918
343000	15KHZ 343000 DFT-s-OFDM 16QAM Inner Full	22.04	20.04	0.1009
343000	15KHZ 343000 DFT-s-OFDM 16QAM Edge 1RB Left	20.45	18.45	0.0700
343000	15KHZ 343000 DFT-s-OFDM 16QAM Edge 1RB Right	19.05	17.05	0.0507
343000	15KHZ 343000 DFT-s-OFDM 16QAM Outer Full	20.61	18.61	0.0726
343000	15KHZ 343000 DFT-s-OFDM 64QAM Edge 1RB Left	19.79	17.79	0.0601
343000	15KHZ 343000 DFT-s-OFDM 64QAM Edge 1RB Right	18.29	16.29	0.0426
343000	15KHZ 343000 DFT-s-OFDM 64QAM Outer Full	20.1	18.10	0.0646
343000	15KHZ 343000 DFT-s-OFDM 256QAM Edge 1RB Left	18.02	16.02	0.0400
343000	15KHZ 343000 DFT-s-OFDM 256QAM Edge 1RB Right	17.95	15.95	0.0394
343000	15KHZ 343000 DFT-s-OFDM 256QAM Outer Full	18.42	16.42	0.0439
343000	15KHZ 343000 CP-OFDM QPSK Inner Full	21.62	19.62	0.0916
343000	15KHZ 343000 CP-OFDM QPSK Edge 1RB Left	20.08	18.08	0.0643
343000	15KHZ 343000 CP-OFDM QPSK Edge 1RB Right	20.44	18.44	0.0698
343000	15KHZ 343000 CP-OFDM QPSK Outer Full	19.96	17.96	0.0625
343000	15KHZ 343000 CP-OFDM 16QAM Inner Full	21.09	19.09	0.0811
343000	15KHZ 343000 CP-OFDM 16QAM Edge 1RB Left	20.06	18.06	0.0640
343000	15KHZ 343000 CP-OFDM 16QAM Edge 1RB Right	20.01	18.01	0.0632
343000	15KHZ 343000 CP-OFDM 16QAM Outer Full	20	18.00	0.0631
343000	15KHZ 343000 CP-OFDM 64QAM Edge 1RB Left	19.24	17.24	0.0530
343000	15KHZ 343000 CP-OFDM 64QAM Edge 1RB Right	19.23	17.23	0.0528
343000	15KHZ 343000 CP-OFDM 64QAM Outer Full	19.44	17.44	0.0541
343000	15KHZ 343000 CP-OFDM 256QAM Edge 1RB Left	15.95	13.95	0.0248
343000	15KHZ 343000 CP-OFDM 256QAM Edge 1RB Right	15.85	13.85	0.0243
343000	15KHZ 343000 CP-OFDM 256QAM Outer Full	16.59	14.59	0.0288
349000	15KHZ 349000 DFT-s-OFDM P1/2 BPSK Inner 1RB Right	23.17	21.17	0.1309
349000	15KHZ 349000 DFT-s-OFDM P1/2 BPSK Inner 1RB Left	23.19	21.19	0.1315
349000	15KHZ 349000 DFT-s-OFDM P1/2 BPSK Inner Full	23.15	21.15	0.1303
349000	15KHZ 349000 DFT-s-OFDM QPSK Inner 1RB Right	23.12	21.12	0.1294
349000	15KHZ 349000 DFT-s-OFDM QPSK Inner 1RB Left	23.16	21.16	0.1306
349000	15KHZ 349000 DFT-s-OFDM QPSK Inner Full	23.2	21.20	0.1318
349000	15KHZ 349000 DFT-s-OFDM P1/2 BPSK Inner Full	23.25	21.25	0.1334
349000	15KHZ 349000 DFT-s-OFDM P1/2 BPSK Edge 1RB Left	22.5	20.50	0.1122
349000	15KHZ 349000 DFT-s-OFDM P1/2 BPSK Edge 1RB Right	22.64	20.64	0.1159
349000	15KHZ 349000 DFT-s-OFDM P1/2 BPSK Outer Full	22.67	20.67	0.1167
349000	15KHZ 349000 DFT-s-OFDM P1/2 BPSK Inner Full	23.25	21.25	0.1334
349000	15KHZ 349000 DFT-s-OFDM P1/2 BPSK Edge 1RB Left	22.62	20.62	0.1153
349000	15KHZ 349000 DFT-s-OFDM P1/2 BPSK Edge 1RB Right	22.68	20.68	0.1169
349000	15KHZ 349000 DFT-s-OFDM P1/2 BPSK Outer Full	22.73	20.73	0.1183
349000	15KHZ 349000 DFT-s-OFDM QPSK Inner Full	23.19	21.19	0.1315
349000	15KHZ 349000 DFT-s-OFDM QPSK Edge 1RB Left	22.2	20.20	0.1047
349000	15KHZ 349000 DFT-s-OFDM QPSK Edge 1RB Right	22.13	20.13	0.1030
349000	15KHZ 349000 DFT-s-OFDM QPSK Outer Full	22.16	20.16	0.1038
349000	15KHZ 349000 DFT-s-OFDM 16QAM Inner Full	22.21	20.21	0.1050
349000	15KHZ 349000 DFT-s-OFDM 16QAM Edge 1RB Left	21.06	19.06	0.0805
349000	15KHZ 349000 DFT-s-OFDM 16QAM Edge 1RB Right	21.1	19.10	0.0813
349000	15KHZ 349000 DFT-s-OFDM 16QAM Outer Full	21.18	19.18	0.0828
349000	15KHZ 349000 DFT-s-OFDM 64QAM Edge 1RB Left	20.67	18.67	0.0736
349000	15KHZ 349000 DFT-s-OFDM 64QAM Edge 1RB Right	20.31	18.31	0.0678
349000	15KHZ 349000 DFT-s-OFDM 64QAM Outer Full	20.71	18.71	0.0743
349000	15KHZ 349000 DFT-s-OFDM 256QAM Edge 1RB Left	18.08	16.08	0.0406
349000	15KHZ 349000 DFT-s-OFDM 256QAM Edge 1RB Right	17.97	15.97	0.0395
349000	15KHZ 349000 DFT-s-OFDM 256QAM Outer Full	18.71	16.71	0.0469
349000	15KHZ 349000 CP-OFDM QPSK Inner Full	21.78	19.78	0.0951
349000	15KHZ 349000 CP-OFDM QPSK Edge 1RB Left	20.4	18.40	0.0692
349000	15KHZ 349000 CP-OFDM QPSK Edge 1RB Right	20.45	18.45	0.0700
349000	15KHZ 349000 CP-OFDM QPSK Outer Full	20	18.00	0.0631
349000	15KHZ 349000 CP-OFDM 16QAM Inner Full	21.19	19.19	0.0830
349000	15KHZ 349000 CP-OFDM 16QAM Edge 1RB Left	20.65	18.65	0.0733
349000	15KHZ 349000 CP-OFDM 16QAM Edge 1RB Right	20.25	18.25	0.0668
349000	15KHZ 349000 CP-OFDM 16QAM Outer Full	20.82	18.82	0.0762
349000	15KHZ 349000 CP-OFDM 64QAM Edge 1RB Left	19.85	17.85	0.0610
349000	15KHZ 349000 CP-OFDM 64QAM Edge 1RB Right	19.29	17.29	0.0536
349000	15KHZ 349000 CP-OFDM 64QAM Outer Full	20.33	18.33	0.0681
349000	15KHZ 349000 CP-OFDM 256QAM Edge 1RB Left	16.98	14.98	0.0315
349000	15KHZ 349000 CP-OFDM 256QAM Edge 1RB Right	15.65	13.65	0.0232
349000	15KHZ 349000 CP-OFDM 256QAM Outer Full	17.46	15.46	0.0352
355000	15KHZ 355000 DFT-s-OFDM P1/2 BPSK Inner 1RB Right	23.01	21.01	0.1262
355000	15KHZ 355000 DFT-s-OFDM P1/2 BPSK Inner 1RB Left	23.12	21.12	0.1294
355000	15KHZ 355000 DFT-s-OFDM P1/2 BPSK Inner Full	23.1	21.10	0.1288
355000	15KHZ 355000 DFT-s-OFDM QPSK Inner 1RB Right	23.05	21.05	0.1273
355000	15KHZ 355000 DFT-s-OFDM QPSK Inner 1RB Left	23.01	21.01	0.1262
355000	15KHZ 355000 DFT-s-OFDM QPSK Inner Full	23.12	21.12	0.1294
355000	15KHZ 355000 DFT-s-OFDM P1/2 BPSK Inner Full	23.04	21.04	0.1271
355000	15KHZ 355000 DFT-s-OFDM P1/2 BPSK Edge 1RB Left	22.56	20.56	0.1138
355000	15KHZ 355000 DFT-s-OFDM P1/2 BPSK Edge 1RB Right	22.44	20.44	0.1107
355000	15KHZ 355000 DFT-s-OFDM P1/2 BPSK Outer Full	22.53	20.53	0.1130
355000	15KHZ 355000 DFT-s-OFDM P1/2 BPSK Inner Full	23.1	21.10	0.1288
355000	15KHZ 355000 DFT-s-OFDM P1/2 BPSK Edge 1RB Left	22.58	20.58	0.1143
355000	15KHZ 355000 DFT-s-OFDM P1/2 BPSK Edge 1RB Right	22.44	20.44	0.1107
355000	15KHZ 355000 DFT-s-OFDM P1/2 BPSK Outer Full	22.63	20.63	0.1156
355000	15KHZ 355000 DFT-s-OFDM QPSK Inner Full	23.13	21.13	0.1297
355000	15KHZ 355000 DFT-s-OFDM QPSK Edge 1RB Left	22.13	20.13	0.1030
355000	15KHZ 355000 DFT-s-OFDM QPSK Edge 1RB Right	21.99	19.99	0.0998
355000	15KHZ 355000 DFT-s-OFDM QPSK Outer Full	22.04	20.04	0.1009
355000	15KHZ 355000 DFT-s-OFDM 16QAM Inner Full	22.03	20.03	0.1007
355000	15KHZ 355000 DFT-s-OFDM 16QAM Edge 1RB Left	21.1	19.10	0.0813
355000	15KHZ 355000 DFT-s-OFDM 16QAM Edge 1RB Right	20.95	18.95	0.0785
355000	15KHZ 355000 DFT-s-OFDM 16QAM Outer Full	21.03	19.03	0.0800
355000	15KHZ 355000 DFT-s-OFDM 64QAM Edge 1RB Left	19.51	17.51	0.0564
355000	15KHZ 355000 DFT-s-OFDM 64QAM Edge 1RB Right	19.41	17.41	0.0551
355000	15KHZ 355000 DFT-s-OFDM 64QAM Outer Full	20.55	18.55	0.0716
355000	15KHZ 355000 DFT-s-OFDM 256QAM Edge 1RB Left	17.87	15.87	0.0386
355000	15KHZ 355000 DFT-s-OFDM 256QAM Edge 1RB Right	18.01	16.01	0.0399
355000	15KHZ 355000 DFT-s-OFDM 256QAM Outer Full	18.51	16.51	0.0448
355000	15KHZ 355000 CP-OFDM QPSK Inner Full	21.18	19.18	0.0828
355000	15KHZ 355000 CP-OFDM QPSK Edge 1RB Left	20.08	18.08	0.0643
355000	15KHZ 355000 CP-OFDM QPSK Edge 1RB Right	20.23	18.23	0.0665
355000	15KHZ 355000 CP-OFDM QPSK Outer Full	19.97	17.97	0.0627
355000	15KHZ 355000 CP-OFDM 16QAM Inner Full	21.09	19.09	0.0811
355000	15KHZ 355000 CP-OFDM 16QAM Edge 1RB Left	20.21	18.21	0.0652
355000	15KHZ 355000 CP-OFDM 16QAM Edge 1RB Right	20.04	18.04	0.0637
355000	15KHZ 355000 CP-OFDM 16QAM Outer Full	20.12	18.12	0.0649
355000	15KHZ 355000 CP-OFDM 64QAM Edge 1RB Left	19.32	17.32	0.0540
355000	15KHZ 355000 CP-OFDM 64QAM Edge 1RB Right	19.14	17.14	0.0518
355000	15KHZ 355000 CP-OFDM 64QAM Outer Full	19.55	17.55	0.0569
355000	15KHZ 355000 CP-OFDM 256QAM Edge 1RB Left	15.92	13.92	0.0247
355000	15KHZ 355000 CP-OFDM 256QAM Edge 1RB Right	15.92	13.92	0.0247
355000	15KHZ 355000 CP-OFDM 256QAM Outer Full	16.68	14.68	0.0294

5G NR
n66-
15MHZ

Channel	TestItem	MeasuredValue	EIRP power (dbm)	EIRP power (dbm)
343500	15KHZ 343500 DFT-s-OFDM P1/2 BPSK Inner 1RB Right	23.39	21.39	0.1377
343500	15KHZ 343500 DFT-s-OFDM P1/2 BPSK Inner 1RB Left	23.12	21.12	0.1294
343500	15KHZ 343500 DFT-s-OFDM P1/2 BPSK Inner Full	23.15	21.15	0.1303
343500	15KHZ 343500 DFT-s-OFDM QPSK Inner 1RB Right	23.18	21.18	0.1312
343500	15KHZ 343500 DFT-s-OFDM QPSK Inner 1RB Left	23.24	21.24	0.1330
343500	15KHZ 343500 DFT-s-OFDM QPSK Inner Full	23.22	21.22	0.1324
343500	15KHZ 343500 DFT-s-OFDM P1/2 BPSK Inner Full	23.27	21.27	0.1340
343500	15KHZ 343500 DFT-s-OFDM P1/2 BPSK Edge 1RB Left	22.69	20.69	0.1172
343500	15KHZ 343500 DFT-s-OFDM P1/2 BPSK Edge 1RB Right	22.78	20.78	0.1197
343500	15KHZ 343500 DFT-s-OFDM P1/2 BPSK Outer Full	22.7	20.70	0.1175
343500	15KHZ 343500 DFT-s-OFDM P1/2 BPSK Inner Full	23.18	21.18	0.1312
343500	15KHZ 343500 DFT-s-OFDM P1/2 BPSK Edge 1RB Left	22.77	20.77	0.1194
343500	15KHZ 343500 DFT-s-OFDM P1/2 BPSK Edge 1RB Right	22.77	20.77	0.1194
343500	15KHZ 343500 DFT-s-OFDM P1/2 BPSK Outer Full	22.74	20.74	0.1186
343500	15KHZ 343500 DFT-s-OFDM QPSK Inner Full	23.23	21.23	0.1327
343500	15KHZ 343500 DFT-s-OFDM QPSK Edge 1RB Left	22.16	20.16	0.1038
343500	15KHZ 343500 DFT-s-OFDM QPSK Edge 1RB Right	21.96	19.96	0.0991
343500	15KHZ 343500 DFT-s-OFDM QPSK Outer Full	22.19	20.19	0.1045
343500	15KHZ 343500 DFT-s-OFDM 16QAM Inner Full	22.19	20.19	0.1045
343500	15KHZ 343500 DFT-s-OFDM 16QAM Edge 1RB Left	21.22	19.22	0.0836
343500	15KHZ 343500 DFT-s-OFDM 16QAM Edge 1RB Right	21.19	19.19	0.0830
343500	15KHZ 343500 DFT-s-OFDM 16QAM Outer Full	21.25	19.25	0.0841
343500	15KHZ 343500 DFT-s-OFDM 64QAM Edge 1RB Left	20.54	18.54	0.0714
343500	15KHZ 343500 DFT-s-OFDM 64QAM Edge 1RB Right	20.22	18.22	0.0664
343500	15KHZ 343500 DFT-s-OFDM 64QAM Outer Full	20.76	18.76	0.0752
343500	15KHZ 343500 DFT-s-OFDM 256QAM Edge 1RB Left	18.07	16.07	0.0405
343500	15KHZ 343500 DFT-s-OFDM 256QAM Edge 1RB Right	18.01	16.01	0.0395
343500	15KHZ 343500 DFT-s-OFDM 256QAM Outer Full	18.75	16.75	0.0473
343500	15KHZ 343500 CP-OFDM QPSK Inner Full	21.69	19.69	0.0931
343500	15KHZ 343500 CP-OFDM QPSK Edge 1RB Left	20.52	18.52	0.0711
343500	15KHZ 343500 CP-OFDM QPSK Edge 1RB Right	20.35	18.35	0.0684
343500	15KHZ 343500 CP-OFDM QPSK Outer Full	20.15	18.15	0.0653
343500	15KHZ 343500 CP-OFDM 16QAM Inner Full	21.24	19.24	0.0839
343500	15KHZ 343500 CP-OFDM 16QAM Edge 1RB Left	20.32	18.32	0.0679
343500	15KHZ 343500 CP-OFDM 16QAM Edge 1RB Right	20.11	18.11	0.0647
343500	15KHZ 343500 CP-OFDM 16QAM Outer Full	20.2	18.20	0.0661
343500	15KHZ 343500 CP-OFDM 64QAM Edge 1RB Left	19.48	17.48	0.0560
343500	15KHZ 343500 CP-OFDM 64QAM Edge 1RB Right	19.34	17.34	0.0542
343500	15KHZ 343500 CP-OFDM 64QAM Outer Full	19.7	17.70	0.0588
343500	15KHZ 343500 CP-OFDM 256QAM Edge 1RB Left	16.23	14.23	0.0265
343500	15KHZ 343500 CP-OFDM 256QAM Edge 1RB Right	15.97	13.97	0.0249
343500	15KHZ 343500 CP-OFDM 256QAM Outer Full	16.75	14.75	0.0299
349000	15KHZ 349000 DFT-s-OFDM P1/2 BPSK Inner 1RB Right	23.35	21.35	0.1365
349000	15KHZ 349000 DFT-s-OFDM P1/2 BPSK Inner 1RB Left	23.46	21.46	0.1400
349000	15KHZ 349000 DFT-s-OFDM P1/2 BPSK Inner Full	23.31	21.31	0.1352
349000	15KHZ 349000 DFT-s-OFDM QPSK Inner 1RB Right	23.25	21.25	0.1334
349000	15KHZ 349000 DFT-s-OFDM QPSK Inner 1RB Left	23.35	21.35	0.1365
349000	15KHZ 349000 DFT-s-OFDM QPSK Inner Full	23.35	21.35	0.1365
349000	15KHZ 349000 DFT-s-OFDM P1/2 BPSK Inner Full	23.43	21.43	0.1390
349000	15KHZ 349000 DFT-s-OFDM P1/2 BPSK Edge 1RB Left	22.72	20.72	0.1180
349000	15KHZ 349000 DFT-s-OFDM P1/2 BPSK Edge 1RB Right	22.72	20.72	0.1180
349000	15KHZ 349000 DFT-s-OFDM P1/2 BPSK Outer Full	22.83	20.83	0.1211
349000	15KHZ 349000 DFT-s-OFDM P1/2 BPSK Inner Full	23.37	21.37	0.1371
349000	15KHZ 349000 DFT-s-OFDM P1/2 BPSK Edge 1RB Left	22.75	20.75	0.1189
349000	15KHZ 349000 DFT-s-OFDM P1/2 BPSK Edge 1RB Right	22.73	20.73	0.1183
349000	15KHZ 349000 DFT-s-OFDM P1/2 BPSK Outer Full	22.83	20.83	0.1211
349000	15KHZ 349000 DFT-s-OFDM QPSK Inner Full	23.36	21.36	0.1368
349000	15KHZ 349000 DFT-s-OFDM QPSK Edge 1RB Left	22.22	20.22	0.1052
349000	15KHZ 349000 DFT-s-OFDM QPSK Edge 1RB Right	22.22	20.22	0.1052
349000	15KHZ 349000 DFT-s-OFDM QPSK Outer Full	22.3	20.30	0.1072
349000	15KHZ 349000 DFT-s-OFDM 16QAM Inner Full	22.36	20.36	0.1086
349000	15KHZ 349000 DFT-s-OFDM 16QAM Edge 1RB Left	21.19	19.19	0.0830
349000	15KHZ 349000 DFT-s-OFDM 16QAM Edge 1RB Right	21.23	19.23	0.0838
349000	15KHZ 349000 DFT-s-OFDM 16QAM Outer Full	21.32	19.32	0.0853
349000	15KHZ 349000 DFT-s-OFDM 64QAM Edge 1RB Left	20.88	18.88	0.0773
349000	15KHZ 349000 DFT-s-OFDM 64QAM Edge 1RB Right	20.51	18.51	0.0710
349000	15KHZ 349000 DFT-s-OFDM 64QAM Outer Full	20.85	18.85	0.0767
349000	15KHZ 349000 DFT-s-OFDM 256QAM Edge 1RB Left	18.22	16.22	0.0419
349000	15KHZ 349000 DFT-s-OFDM 256QAM Edge 1RB Right	18.03	16.03	0.0401
349000	15KHZ 349000 DFT-s-OFDM 256QAM Outer Full	18.86	16.86	0.0485
349000	15KHZ 349000 CP-OFDM QPSK Inner Full	21.79	19.79	0.0953
349000	15KHZ 349000 CP-OFDM QPSK Edge 1RB Left	20.55	18.55	0.0716
349000	15KHZ 349000 CP-OFDM QPSK Edge 1RB Right	20.6	18.60	0.0724
349000	15KHZ 349000 CP-OFDM QPSK Outer Full	20.27	18.27	0.0671
349000	15KHZ 349000 CP-OFDM 16QAM Inner Full	21.08	19.08	0.0809
349000	15KHZ 349000 CP-OFDM 16QAM Edge 1RB Left	20.47	18.47	0.0703
349000	15KHZ 349000 CP-OFDM 16QAM Edge 1RB Right	20.33	18.33	0.0681
349000	15KHZ 349000 CP-OFDM 16QAM Outer Full	20.3	18.30	0.0676
349000	15KHZ 349000 CP-OFDM 64QAM Edge 1RB Left	19.59	17.59	0.0574
349000	15KHZ 349000 CP-OFDM 64QAM Edge 1RB Right	19.52	17.52	0.0565
349000	15KHZ 349000 CP-OFDM 64QAM Outer Full	19.88	17.88	0.0614
349000	15KHZ 349000 CP-OFDM 256QAM Edge 1RB Left	16.36	14.36	0.0273
349000	15KHZ 349000 CP-OFDM 256QAM Edge 1RB Right	16.07	14.07	0.0255
349000	15KHZ 349000 CP-OFDM 256QAM Outer Full	16.9	14.90	0.0309
354500	15KHZ 354500 DFT-s-OFDM P1/2 BPSK Inner 1RB Right	23.29	21.29	0.1346
354500	15KHZ 354500 DFT-s-OFDM P1/2 BPSK Inner 1RB Left	23.37	21.37	0.1371
354500	15KHZ 354500 DFT-s-OFDM P1/2 BPSK Inner Full	23.25	21.25	0.1334
354500	15KHZ 354500 DFT-s-OFDM QPSK Inner 1RB Right	23.21	21.21	0.1322
354500	15KHZ 354500 DFT-s-OFDM QPSK Inner 1RB Left	23.32	21.32	0.1355
354500	15KHZ 354500 DFT-s-OFDM QPSK Inner Full	23.26	21.26	0.1337
354500	15KHZ 354500 DFT-s-OFDM P1/2 BPSK Inner Full	23.21	21.21	0.1321
354500	15KHZ 354500 DFT-s-OFDM P1/2 BPSK Edge 1RB Left	22.72	20.72	0.1180
354500	15KHZ 354500 DFT-s-OFDM P1/2 BPSK Edge 1RB Right	22.65	20.65	0.1161
354500	15KHZ 354500 DFT-s-OFDM P1/2 BPSK Outer Full	22.79	20.79	0.1199
354500	15KHZ 354500 DFT-s-OFDM P1/2 BPSK Inner Full	23.16	21.16	0.1306
354500	15KHZ 354500 DFT-s-OFDM P1/2 BPSK Edge 1RB Left	22.72	20.72	0.1180
354500	15KHZ 354500 DFT-s-OFDM P1/2 BPSK Edge 1RB Right	22.64	20.64	0.1159
354500	15KHZ 354500 DFT-s-OFDM P1/2 BPSK Outer Full	22.74	20.74	0.1186
354500	15KHZ 354500 DFT-s-OFDM QPSK Inner Full	23.25	21.25	0.1334
354500	15KHZ 354500 DFT-s-OFDM QPSK Edge 1RB Left	22.12	20.12	0.1028
354500	15KHZ 354500 DFT-s-OFDM QPSK Edge 1RB Right	22.11	20.11	0.1026
354500	15KHZ 354500 DFT-s-OFDM QPSK Outer Full	22.25	20.25	0.1059
354500	15KHZ 354500 DFT-s-OFDM 16QAM Inner Full	22.31	20.31	0.1074
354500	15KHZ 354500 DFT-s-OFDM 16QAM Edge 1RB Left	21.29	19.29	0.0849
354500	15KHZ 354500 DFT-s-OFDM 16QAM Edge 1RB Right	21.2	19.20	0.0832
354500	15KHZ 354500 DFT-s-OFDM 16QAM Outer Full	21.21	19.21	0.0834
354500	15KHZ 354500 DFT-s-OFDM 64QAM Edge 1RB Left	20.62	18.62	0.0728
354500	15KHZ 354500 DFT-s-OFDM 64QAM Edge 1RB Right	20.55	18.55	0.0716
354500	15KHZ 354500 DFT-s-OFDM 64QAM Outer Full	20.77	18.77	0.0753
354500	15KHZ 354500 DFT-s-OFDM 256QAM Edge 1RB Left	18.26	16.26	0.0423
354500	15KHZ 354500 DFT-s-OFDM 256QAM Edge 1RB Right	18.07	16.07	0.0405
354500	15KHZ 354500 DFT-s-OFDM 256QAM Outer Full	18.32	16.32	0.0462
354500	15KHZ 354500 CP-OFDM QPSK Inner Full	21.68	19.68	0.0929
354500	15KHZ 354500 CP-OFDM QPSK Edge 1RB Left	20.51	18.51	0.0710
354500	15KHZ 354500 CP-OFDM QPSK Edge 1RB Right	20.15	18.15	0.0653
354500	15KHZ 354500 CP-OFDM QPSK Outer Full	20.18	18.18	0.0658
354500	15KHZ 354500 CP-OFDM 16QAM Inner Full	21.22	19.22	0.0836
354500	15KHZ 354500 CP-OFDM 16QAM Edge 1RB Left	20.38	18.38	0.0689
354500	15KHZ 354500 CP-OFDM 16QAM Edge 1RB Right	20.21	18.21	0.0662
354500	15KHZ 354500 CP-OFDM 16QAM Outer Full	20.18	18.18	0.0658
354500	15KHZ 354500 CP-OFDM 64QAM Edge 1RB Left	19.49	17.49	0.0561
354500	15KHZ 354500 CP-OFDM 64QAM Edge 1RB Right	19.35	17.35	0.0543
354500	15KHZ 354500 CP-OFDM 64QAM Outer Full	19.72	17.72	0.0592
354500	15KHZ 354500 CP-OFDM 256QAM Edge 1RB Left	16.54	14.54	0.0284
354500	15KHZ 354500 CP-OFDM 256QAM Edge 1RB Right	16.19	14.19	0.0262
354500	15KHZ 354500 CP-OFDM 256QAM Outer Full	16.83	14.83	0.0304

5G NR
n66-
20MHz

Channel	TestItem	MeasuredValue	EIRP power (dbm)	EIRP power (dbm)
344000	15KHZ 344000 DFT-s-OFDM PI/2 BPSK Inner 1RB Right	23.17	21.17	0.1309
344000	15KHZ 344000 DFT-s-OFDM PI/2 BPSK Inner 1RB Left	23.78	21.78	0.1507
344000	15KHZ 344000 DFT-s-OFDM PI/2 BPSK Inner Full	23.23	21.23	0.1327
344000	15KHZ 344000 DFT-s-OFDM QPSK Inner 1RB Right	23.18	21.18	0.1312
344000	15KHZ 344000 DFT-s-OFDM QPSK Inner 1RB Left	23.12	21.12	0.1294
344000	15KHZ 344000 DFT-s-OFDM QPSK Inner Full	23.41	21.41	0.1384
344000	15KHZ 344000 DFT-s-OFDM PI/2 BPSK Inner Full	23.39	21.39	0.1377
344000	15KHZ 344000 DFT-s-OFDM PI/2 BPSK Edge 1RB Left	22.64	20.64	0.1159
344000	15KHZ 344000 DFT-s-OFDM PI/2 BPSK Edge 1RB Right	22.77	20.77	0.1194
344000	15KHZ 344000 DFT-s-OFDM PI/2 BPSK Outer Full	22.6	20.60	0.1148
344000	15KHZ 344000 DFT-s-OFDM PI/2 BPSK Inner Full	23.21	21.21	0.1321
344000	15KHZ 344000 DFT-s-OFDM PI/2 BPSK Edge 1RB Left	22.61	20.61	0.1151
344000	15KHZ 344000 DFT-s-OFDM PI/2 BPSK Edge 1RB Right	22.57	20.57	0.1140
344000	15KHZ 344000 DFT-s-OFDM PI/2 BPSK Outer Full	22.67	20.67	0.1167
344000	15KHZ 344000 DFT-s-OFDM QPSK Inner Full	23.37	21.37	0.1371
344000	15KHZ 344000 DFT-s-OFDM QPSK Edge 1RB Left	22.23	20.23	0.1054
344000	15KHZ 344000 DFT-s-OFDM QPSK Edge 1RB Right	22.17	20.17	0.1040
344000	15KHZ 344000 DFT-s-OFDM QPSK Outer Full	22.31	20.31	0.1074
344000	15KHZ 344000 DFT-s-OFDM 16QAM Inner Full	22.32	20.32	0.1076
344000	15KHZ 344000 DFT-s-OFDM 16QAM Edge 1RB Left	21.14	19.14	0.0820
344000	15KHZ 344000 DFT-s-OFDM 16QAM Edge 1RB Right	21.06	19.06	0.0805
344000	15KHZ 344000 DFT-s-OFDM 16QAM Outer Full	21.27	19.27	0.0845
344000	15KHZ 344000 DFT-s-OFDM 64QAM Edge 1RB Left	20.48	18.48	0.0705
344000	15KHZ 344000 DFT-s-OFDM 64QAM Edge 1RB Right	20.33	18.33	0.0681
344000	15KHZ 344000 DFT-s-OFDM 64QAM Outer Full	20.84	18.84	0.0766
344000	15KHZ 344000 DFT-s-OFDM 256QAM Edge 1RB Left	17.91	15.91	0.0390
344000	15KHZ 344000 DFT-s-OFDM 256QAM Edge 1RB Right	17.8	15.80	0.0380
344000	15KHZ 344000 DFT-s-OFDM 256QAM Outer Full	18.67	16.67	0.0465
344000	15KHZ 344000 CP-OFDM QPSK Inner Full	21.69	19.69	0.0931
344000	15KHZ 344000 CP-OFDM QPSK Edge 1RB Left	20.32	18.32	0.0679
344000	15KHZ 344000 CP-OFDM QPSK Edge 1RB Right	20.19	18.19	0.0659
344000	15KHZ 344000 CP-OFDM QPSK Outer Full	20.31	18.31	0.0678
344000	15KHZ 344000 CP-OFDM 16QAM Inner Full	20.99	18.99	0.0793
344000	15KHZ 344000 CP-OFDM 16QAM Edge 1RB Left	20.24	18.24	0.0667
344000	15KHZ 344000 CP-OFDM 16QAM Edge 1RB Right	20.22	18.22	0.0664
344000	15KHZ 344000 CP-OFDM 16QAM Outer Full	20.22	18.22	0.0664
344000	15KHZ 344000 CP-OFDM 64QAM Edge 1RB Left	19.51	17.51	0.0564
344000	15KHZ 344000 CP-OFDM 64QAM Edge 1RB Right	19.42	17.42	0.0552
344000	15KHZ 344000 CP-OFDM 64QAM Outer Full	18.77	17.77	0.0508
344000	15KHZ 344000 CP-OFDM 256QAM Edge 1RB Left	16.19	14.19	0.0262
344000	15KHZ 344000 CP-OFDM 256QAM Edge 1RB Right	16	14.00	0.0251
344000	15KHZ 344000 CP-OFDM 256QAM Outer Full	16.78	14.78	0.0301
349000	15KHZ 349000 DFT-s-OFDM PI/2 BPSK Inner 1RB Right	23.26	21.26	0.1337
349000	15KHZ 349000 DFT-s-OFDM PI/2 BPSK Inner 1RB Left	23.2	21.20	0.1318
349000	15KHZ 349000 DFT-s-OFDM PI/2 BPSK Inner Full	23.35	21.35	0.1365
349000	15KHZ 349000 DFT-s-OFDM QPSK Inner 1RB Right	23.11	21.11	0.1291
349000	15KHZ 349000 DFT-s-OFDM QPSK Inner 1RB Left	23.27	21.27	0.1340
349000	15KHZ 349000 DFT-s-OFDM QPSK Inner Full	23.38	21.38	0.1374
349000	15KHZ 349000 DFT-s-OFDM PI/2 BPSK Inner Full	23.36	21.36	0.1368
349000	15KHZ 349000 DFT-s-OFDM PI/2 BPSK Edge 1RB Left	22.66	20.66	0.1164
349000	15KHZ 349000 DFT-s-OFDM PI/2 BPSK Edge 1RB Right	22.7	20.70	0.1175
349000	15KHZ 349000 DFT-s-OFDM PI/2 BPSK Outer Full	22.74	20.74	0.1186
349000	15KHZ 349000 DFT-s-OFDM PI/2 BPSK Inner Full	23.32	21.32	0.1355
349000	15KHZ 349000 DFT-s-OFDM PI/2 BPSK Edge 1RB Left	22.67	20.67	0.1167
349000	15KHZ 349000 DFT-s-OFDM PI/2 BPSK Edge 1RB Right	22.63	20.63	0.1156
349000	15KHZ 349000 DFT-s-OFDM PI/2 BPSK Outer Full	22.82	20.82	0.1208
349000	15KHZ 349000 DFT-s-OFDM QPSK Inner Full	23.3	21.30	0.1349
349000	15KHZ 349000 DFT-s-OFDM QPSK Edge 1RB Left	22.15	20.15	0.1035
349000	15KHZ 349000 DFT-s-OFDM QPSK Edge 1RB Right	22.18	20.18	0.1042
349000	15KHZ 349000 DFT-s-OFDM QPSK Outer Full	22.34	20.34	0.1081
349000	15KHZ 349000 DFT-s-OFDM 16QAM Inner Full	22.35	20.35	0.1084
349000	15KHZ 349000 DFT-s-OFDM 16QAM Edge 1RB Left	21.17	19.17	0.0826
349000	15KHZ 349000 DFT-s-OFDM 16QAM Edge 1RB Right	21.11	19.11	0.0815
349000	15KHZ 349000 DFT-s-OFDM 16QAM Outer Full	21.27	19.27	0.0845
349000	15KHZ 349000 DFT-s-OFDM 64QAM Edge 1RB Left	20.61	18.61	0.0726
349000	15KHZ 349000 DFT-s-OFDM 64QAM Edge 1RB Right	20.49	18.49	0.0706
349000	15KHZ 349000 DFT-s-OFDM 64QAM Outer Full	20.84	18.84	0.0766
349000	15KHZ 349000 DFT-s-OFDM 256QAM Edge 1RB Left	18.15	16.15	0.0412
349000	15KHZ 349000 DFT-s-OFDM 256QAM Edge 1RB Right	18.02	16.02	0.0400
349000	15KHZ 349000 DFT-s-OFDM 256QAM Outer Full	18.78	16.78	0.0476
349000	15KHZ 349000 CP-OFDM QPSK Inner Full	21.82	19.82	0.0959
349000	15KHZ 349000 CP-OFDM QPSK Edge 1RB Left	20.53	18.53	0.0713
349000	15KHZ 349000 CP-OFDM QPSK Edge 1RB Right	20.28	18.28	0.0673
349000	15KHZ 349000 CP-OFDM QPSK Outer Full	20.26	18.26	0.0670
349000	15KHZ 349000 CP-OFDM 16QAM Inner Full	21.3	19.30	0.0851
349000	15KHZ 349000 CP-OFDM 16QAM Edge 1RB Left	20.28	18.28	0.0673
349000	15KHZ 349000 CP-OFDM 16QAM Edge 1RB Right	20.2	18.20	0.0661
349000	15KHZ 349000 CP-OFDM 16QAM Outer Full	20.25	18.25	0.0668
349000	15KHZ 349000 CP-OFDM 64QAM Edge 1RB Left	19.53	17.53	0.0566
349000	15KHZ 349000 CP-OFDM 64QAM Edge 1RB Right	19.5	17.50	0.0562
349000	15KHZ 349000 CP-OFDM 64QAM Outer Full	19.71	17.71	0.0590
349000	15KHZ 349000 CP-OFDM 256QAM Edge 1RB Left	16.19	14.19	0.0262
349000	15KHZ 349000 CP-OFDM 256QAM Edge 1RB Right	16.04	14.04	0.0254
349000	15KHZ 349000 CP-OFDM 256QAM Outer Full	16.87	14.87	0.0307
354000	15KHZ 354000 DFT-s-OFDM PI/2 BPSK Inner 1RB Right	23.26	21.26	0.1337
354000	15KHZ 354000 DFT-s-OFDM PI/2 BPSK Inner 1RB Left	23.22	21.22	0.1324
354000	15KHZ 354000 DFT-s-OFDM PI/2 BPSK Inner Full	23.29	21.29	0.1346
354000	15KHZ 354000 DFT-s-OFDM QPSK Inner 1RB Right	23.16	21.16	0.1306
354000	15KHZ 354000 DFT-s-OFDM QPSK Inner 1RB Left	23.26	21.26	0.1337
354000	15KHZ 354000 DFT-s-OFDM QPSK Inner Full	23.28	21.28	0.1343
354000	15KHZ 354000 DFT-s-OFDM PI/2 BPSK Inner Full	23.19	21.19	0.1315
354000	15KHZ 354000 DFT-s-OFDM PI/2 BPSK Edge 1RB Left	22.59	20.59	0.1146
354000	15KHZ 354000 DFT-s-OFDM PI/2 BPSK Edge 1RB Right	22.59	20.59	0.1146
354000	15KHZ 354000 DFT-s-OFDM PI/2 BPSK Outer Full	22.69	20.69	0.1172
354000	15KHZ 354000 DFT-s-OFDM PI/2 BPSK Inner Full	23.25	21.25	0.1334
354000	15KHZ 354000 DFT-s-OFDM PI/2 BPSK Edge 1RB Left	22.66	20.66	0.1164
354000	15KHZ 354000 DFT-s-OFDM PI/2 BPSK Edge 1RB Right	22.6	20.60	0.1148
354000	15KHZ 354000 DFT-s-OFDM PI/2 BPSK Outer Full	22.67	20.67	0.1167
354000	15KHZ 354000 DFT-s-OFDM QPSK Inner Full	23.37	21.37	0.1371
354000	15KHZ 354000 DFT-s-OFDM QPSK Edge 1RB Left	22.14	20.14	0.1033
354000	15KHZ 354000 DFT-s-OFDM QPSK Edge 1RB Right	22.13	20.13	0.1030
354000	15KHZ 354000 DFT-s-OFDM QPSK Outer Full	22.15	20.15	0.1035
354000	15KHZ 354000 DFT-s-OFDM 16QAM Inner Full	22.31	20.31	0.1074
354000	15KHZ 354000 DFT-s-OFDM 16QAM Edge 1RB Left	21.1	19.10	0.0813
354000	15KHZ 354000 DFT-s-OFDM 16QAM Edge 1RB Right	21.1	19.10	0.0813
354000	15KHZ 354000 DFT-s-OFDM 16QAM Outer Full	21.31	19.31	0.0853
354000	15KHZ 354000 DFT-s-OFDM 64QAM Edge 1RB Left	20.71	18.71	0.0743
354000	15KHZ 354000 DFT-s-OFDM 64QAM Edge 1RB Right	20.45	18.45	0.0700
354000	15KHZ 354000 DFT-s-OFDM 64QAM Outer Full	20.79	18.79	0.0757
354000	15KHZ 354000 DFT-s-OFDM 256QAM Edge 1RB Left	18.07	16.07	0.0405
354000	15KHZ 354000 DFT-s-OFDM 256QAM Edge 1RB Right	17.89	15.89	0.0388
354000	15KHZ 354000 DFT-s-OFDM 256QAM Outer Full	18.73	16.73	0.0471
354000	15KHZ 354000 CP-OFDM QPSK Inner Full	21.8	19.80	0.0955
354000	15KHZ 354000 CP-OFDM QPSK Edge 1RB Left	20.4	18.40	0.0692
354000	15KHZ 354000 CP-OFDM QPSK Edge 1RB Right	20.35	18.35	0.0684
354000	15KHZ 354000 CP-OFDM QPSK Outer Full	20.24	18.24	0.0667
354000	15KHZ 354000 CP-OFDM 16QAM Inner Full	21.18	19.18	0.0828
354000	15KHZ 354000 CP-OFDM 16QAM Edge 1RB Left	20.28	18.28	0.0673
354000	15KHZ 354000 CP-OFDM 16QAM Edge 1RB Right	20.13	18.13	0.0650
354000	15KHZ 354000 CP-OFDM 16QAM Outer Full	20.18	18.18	0.0658
354000	15KHZ 354000 CP-OFDM 64QAM Edge 1RB Left	19.33	17.33	0.0541
354000	15KHZ 354000 CP-OFDM 64QAM Edge 1RB Right	19.41	17.41	0.0551
354000	15KHZ 354000 CP-OFDM 64QAM Outer Full	19.63	17.63	0.0579
354000	15KHZ 354000 CP-OFDM 256QAM Edge 1RB Left	16.25	14.25	0.0266
354000	15KHZ 354000 CP-OFDM 256QAM Edge 1RB Right	16.11	14.11	0.0258
354000	15KHZ 354000 CP-OFDM 256QAM Outer Full	16.85	14.85	0.0305

5G NR	Channel	TestItem	MeasuredValue	ERP power (dbm)	ERP power (W)
n71-5MHZ	133100	15KHZ 133100 DFT-s-OFDM P1/2 BPSK Inner 1RB Right	23.23	18.08	0.0643
	133100	15KHZ 133100 DFT-s-OFDM P1/2 BPSK Inner 1RB Left	23.42	18.27	0.0671
	133100	15KHZ 133100 DFT-s-OFDM P1/2 BPSK Inner Full	23.35	18.20	0.0661
	133100	15KHZ 133100 DFT-s-OFDM QPSK Inner 1RB Right	23.15	18.00	0.0631
	133100	15KHZ 133100 DFT-s-OFDM QPSK Inner 1RB Left	23.45	18.30	0.0676
	133100	15KHZ 133100 DFT-s-OFDM QPSK Inner Full	23.31	18.16	0.0655
	133100	15KHZ 133100 DFT-s-OFDM P1/2 BPSK Inner Full	23.54	18.39	0.0690
	133100	15KHZ 133100 DFT-s-OFDM P1/2 BPSK Edge 1RB Left	23.47	18.32	0.0679
	133100	15KHZ 133100 DFT-s-OFDM P1/2 BPSK Edge 1RB Right	23.75	18.60	0.0724
	133100	15KHZ 133100 DFT-s-OFDM P1/2 BPSK Outer Full	23.78	18.63	0.0729
	133100	15KHZ 133100 DFT-s-OFDM QPSK Edge 1RB Left	23.25	18.10	0.0646
	133100	15KHZ 133100 DFT-s-OFDM QPSK Edge 1RB Right	23.06	17.91	0.0618
	133100	15KHZ 133100 DFT-s-OFDM QPSK Outer Full	23.3	18.15	0.0653
	133100	15KHZ 133100 DFT-s-OFDM 16QAM Inner Full	22.39	17.24	0.0530
	133100	15KHZ 133100 DFT-s-OFDM 16QAM Edge 1RB Left	21.35	16.20	0.0417
	133100	15KHZ 133100 DFT-s-OFDM 16QAM Edge 1RB Right	21.29	16.14	0.0411
	133100	15KHZ 133100 DFT-s-OFDM 16QAM Outer Full	21.23	16.08	0.0406
	133100	15KHZ 133100 DFT-s-OFDM 64QAM Edge 1RB Left	20.62	15.47	0.0352
	133100	15KHZ 133100 DFT-s-OFDM 64QAM Edge 1RB Right	20.41	15.26	0.0336
	133100	15KHZ 133100 DFT-s-OFDM 64QAM Outer Full	20.84	15.69	0.0371
	133100	15KHZ 133100 DFT-s-OFDM 256QAM Edge 1RB Left	18.52	13.37	0.0217
	133100	15KHZ 133100 DFT-s-OFDM 256QAM Edge 1RB Right	18.26	13.11	0.0205
	133100	15KHZ 133100 DFT-s-OFDM 256QAM Outer Full	19.06	13.91	0.0246
	133100	15KHZ 133100 CP-OFDM QPSK Inner Full	21.83	16.68	0.0466
	133100	15KHZ 133100 CP-OFDM QPSK Edge 1RB Left	20.54	15.39	0.0346
	133100	15KHZ 133100 CP-OFDM QPSK Edge 1RB Right	20.38	15.23	0.0333
	133100	15KHZ 133100 CP-OFDM QPSK Outer Full	20.29	15.14	0.0327
	133100	15KHZ 133100 CP-OFDM 16QAM Inner Full	21.23	16.08	0.0406
	133100	15KHZ 133100 CP-OFDM 16QAM Edge 1RB Left	20.62	15.47	0.0352
	133100	15KHZ 133100 CP-OFDM 16QAM Edge 1RB Right	20.39	15.24	0.0334
	133100	15KHZ 133100 CP-OFDM 16QAM Outer Full	20.3	15.15	0.0327
	133100	15KHZ 133100 CP-OFDM 64QAM Edge 1RB Left	19.98	14.83	0.0304
	133100	15KHZ 133100 CP-OFDM 64QAM Edge 1RB Right	19.73	14.58	0.0287
	133100	15KHZ 133100 CP-OFDM 64QAM Outer Full	20.01	14.86	0.0306
	133100	15KHZ 133100 CP-OFDM 256QAM Edge 1RB Left	16.4	11.25	0.0133
	133100	15KHZ 133100 CP-OFDM 256QAM Edge 1RB Right	16.15	11.00	0.0126
	133100	15KHZ 133100 CP-OFDM 256QAM Outer Full	16.98	11.83	0.0152
	136100	15KHZ 136100 DFT-s-OFDM P1/2 BPSK Inner 1RB Right	22.74	17.59	0.0574
	136100	15KHZ 136100 DFT-s-OFDM P1/2 BPSK Inner 1RB Left	22.45	17.30	0.0537
	136100	15KHZ 136100 DFT-s-OFDM P1/2 BPSK Inner Full	22.49	17.34	0.0542
	136100	15KHZ 136100 DFT-s-OFDM P1/2 BPSK Inner Full	22.6	17.45	0.0556
	136100	15KHZ 136100 DFT-s-OFDM P1/2 BPSK Inner Full	22.48	17.33	0.0541
	136100	15KHZ 136100 DFT-s-OFDM QPSK Inner 1RB Right	22.51	17.36	0.0545
	136100	15KHZ 136100 DFT-s-OFDM QPSK Inner 1RB Left	22.43	17.28	0.0535
	136100	15KHZ 136100 DFT-s-OFDM QPSK Inner Full	22.48	17.33	0.0541
	136100	15KHZ 136100 DFT-s-OFDM P1/2 BPSK Inner Full	23.61	18.46	0.0701
	136100	15KHZ 136100 DFT-s-OFDM P1/2 BPSK Edge 1RB Left	22.99	17.84	0.0608
	136100	15KHZ 136100 DFT-s-OFDM P1/2 BPSK Edge 1RB Right	22.94	17.79	0.0601
	136100	15KHZ 136100 DFT-s-OFDM P1/2 BPSK Outer Full	23.03	17.88	0.0614
	136100	15KHZ 136100 DFT-s-OFDM QPSK Inner Full	23.55	18.40	0.0692
	136100	15KHZ 136100 DFT-s-OFDM QPSK Edge 1RB Left	22.31	17.16	0.0520
	136100	15KHZ 136100 DFT-s-OFDM QPSK Edge 1RB Right	22.44	17.29	0.0536
	136100	15KHZ 136100 DFT-s-OFDM QPSK Outer Full	22.43	17.28	0.0535
	136100	15KHZ 136100 DFT-s-OFDM 16QAM Inner Full	22.58	17.43	0.0553
	136100	15KHZ 136100 DFT-s-OFDM 16QAM Edge 1RB Left	21.5	16.35	0.0432
	136100	15KHZ 136100 DFT-s-OFDM 16QAM Edge 1RB Right	21.61	16.46	0.0443
	136100	15KHZ 136100 DFT-s-OFDM 16QAM Outer Full	21.61	16.46	0.0443
	136100	15KHZ 136100 DFT-s-OFDM 64QAM Edge 1RB Left	20.64	15.49	0.0354
	136100	15KHZ 136100 DFT-s-OFDM 64QAM Edge 1RB Right	20.77	15.62	0.0365
	136100	15KHZ 136100 DFT-s-OFDM 64QAM Outer Full	21.06	15.91	0.0390
	136100	15KHZ 136100 DFT-s-OFDM 256QAM Edge 1RB Left	18.29	13.14	0.0206
	136100	15KHZ 136100 DFT-s-OFDM 256QAM Edge 1RB Right	18.36	13.21	0.0209
	136100	15KHZ 136100 DFT-s-OFDM 256QAM Outer Full	18.91	13.76	0.0238
	136100	15KHZ 136100 CP-OFDM QPSK Inner Full	22.03	16.88	0.0488
	136100	15KHZ 136100 CP-OFDM QPSK Edge 1RB Left	20.49	15.34	0.0342
	136100	15KHZ 136100 CP-OFDM QPSK Edge 1RB Right	20.69	15.54	0.0358
	136100	15KHZ 136100 CP-OFDM QPSK Outer Full	20.43	15.28	0.0337
	136100	15KHZ 136100 CP-OFDM 16QAM Inner Full	21.4	16.25	0.0422
	136100	15KHZ 136100 CP-OFDM 16QAM Edge 1RB Left	20.5	15.35	0.0343
	136100	15KHZ 136100 CP-OFDM 16QAM Edge 1RB Right	20.54	15.39	0.0346
	136100	15KHZ 136100 CP-OFDM 16QAM Outer Full	20.55	15.40	0.0347
	136100	15KHZ 136100 CP-OFDM 64QAM Edge 1RB Left	19.74	14.59	0.0288
	136100	15KHZ 136100 CP-OFDM 64QAM Edge 1RB Right	19.69	14.54	0.0284
	136100	15KHZ 136100 CP-OFDM 64QAM Outer Full	19.91	14.76	0.0299
	136100	15KHZ 136100 CP-OFDM 256QAM Edge 1RB Left	16.13	10.98	0.0125
	136100	15KHZ 136100 CP-OFDM 256QAM Edge 1RB Right	16.14	10.99	0.0126
	136100	15KHZ 136100 CP-OFDM 256QAM Outer Full	16.94	11.79	0.0151
	139100	15KHZ 139100 DFT-s-OFDM P1/2 BPSK Inner 1RB Right	22.39	17.24	0.0530
	139100	15KHZ 139100 DFT-s-OFDM P1/2 BPSK Inner 1RB Left	22.38	17.23	0.0528
	139100	15KHZ 139100 DFT-s-OFDM P1/2 BPSK Inner Full	22.49	17.34	0.0542
	139100	15KHZ 139100 DFT-s-OFDM QPSK Inner 1RB Right	22.28	17.13	0.0516
	139100	15KHZ 139100 DFT-s-OFDM QPSK Inner 1RB Left	22.32	17.17	0.0521
	139100	15KHZ 139100 DFT-s-OFDM QPSK Inner Full	22.38	17.23	0.0528
	139100	15KHZ 139100 DFT-s-OFDM P1/2 BPSK Inner Full	23.29	18.14	0.0652
	139100	15KHZ 139100 DFT-s-OFDM P1/2 BPSK Edge 1RB Left	23.01	17.86	0.0611
	139100	15KHZ 139100 DFT-s-OFDM P1/2 BPSK Edge 1RB Right	22.68	17.53	0.0566
	139100	15KHZ 139100 DFT-s-OFDM P1/2 BPSK Outer Full	22.83	17.68	0.0586
	139100	15KHZ 139100 DFT-s-OFDM QPSK Inner Full	23.32	18.17	0.0656
	139100	15KHZ 139100 DFT-s-OFDM QPSK Edge 1RB Left	22.32	17.17	0.0521
	139100	15KHZ 139100 DFT-s-OFDM QPSK Edge 1RB Right	22.24	17.09	0.0512
	139100	15KHZ 139100 DFT-s-OFDM QPSK Outer Full	22.29	17.14	0.0518
	139100	15KHZ 139100 DFT-s-OFDM 16QAM Inner Full	22.21	17.06	0.0508
	139100	15KHZ 139100 DFT-s-OFDM 16QAM Edge 1RB Left	21.37	16.22	0.0419
	139100	15KHZ 139100 DFT-s-OFDM 16QAM Edge 1RB Right	21.27	16.12	0.0409
	139100	15KHZ 139100 DFT-s-OFDM 16QAM Outer Full	21.42	16.27	0.0424
	139100	15KHZ 139100 DFT-s-OFDM 64QAM Edge 1RB Left	20.66	15.51	0.0356
	139100	15KHZ 139100 DFT-s-OFDM 64QAM Edge 1RB Right	20.56	15.41	0.0348
	139100	15KHZ 139100 DFT-s-OFDM 64QAM Outer Full	20.94	15.79	0.0379
	139100	15KHZ 139100 DFT-s-OFDM 256QAM Edge 1RB Left	18.33	13.18	0.0208
	139100	15KHZ 139100 DFT-s-OFDM 256QAM Edge 1RB Right	18.21	13.06	0.0202
	139100	15KHZ 139100 DFT-s-OFDM 256QAM Outer Full	18.83	13.68	0.0233
	139100	15KHZ 139100 CP-OFDM QPSK Inner Full	21.28	16.13	0.0410
	139100	15KHZ 139100 CP-OFDM QPSK Edge 1RB Left	20.37	15.22	0.0333
	139100	15KHZ 139100 CP-OFDM QPSK Edge 1RB Right	20.44	15.29	0.0338
	139100	15KHZ 139100 CP-OFDM QPSK Outer Full	20.28	15.13	0.0326
	139100	15KHZ 139100 CP-OFDM 16QAM Inner Full	21.21	16.06	0.0404
	139100	15KHZ 139100 CP-OFDM 16QAM Edge 1RB Left	20.59	15.44	0.0350
	139100	15KHZ 139100 CP-OFDM 16QAM Edge 1RB Right	20.31	15.16	0.0328
	139100	15KHZ 139100 CP-OFDM 16QAM Outer Full	20.38	15.23	0.0333
	139100	15KHZ 139100 CP-OFDM 64QAM Edge 1RB Left	19.86	14.71	0.0296
	139100	15KHZ 139100 CP-OFDM 64QAM Edge 1RB Right	19.57	14.42	0.0277
	139100	15KHZ 139100 CP-OFDM 64QAM Outer Full	19.95	14.80	0.0302
	139100	15KHZ 139100 CP-OFDM 256QAM Edge 1RB Left	16.31	11.16	0.0131
	139100	15KHZ 139100 CP-OFDM 256QAM Edge 1RB Right	16.14	10.99	0.0126
	139100	15KHZ 139100 CP-OFDM 256QAM Outer Full	16.89	11.74	0.0149

5G NR n71- 10MHZ	Channel	TestItem	MeasuredValue	EIRP power (dbm)	EIRP power (W)
	133600	15KHZ 133600 DFT-s-OFDM P1/2 BPSK Inner 1RB Right	23.17	18.02	0.0634
	133600	15KHZ 133600 DFT-s-OFDM P1/2 BPSK Inner 1RB Left	23.39	18.24	0.0667
	133600	15KHZ 133600 DFT-s-OFDM P1/2 BPSK Inner Full	23.25	18.10	0.0646
	133600	15KHZ 133600 DFT-s-OFDM QPSK Inner 1RB Right	23.23	18.08	0.0643
	133600	15KHZ 133600 DFT-s-OFDM QPSK Inner 1RB Left	23.41	18.26	0.0670
	133600	15KHZ 133600 DFT-s-OFDM QPSK Inner Full	23.39	18.24	0.0667
	133600	15KHZ 133600 DFT-s-OFDM P1/2 BPSK Inner Full	23.43	18.28	0.0673
	133600	15KHZ 133600 DFT-s-OFDM P1/2 BPSK Edge 1RB Left	22.98	17.83	0.0607
	133600	15KHZ 133600 DFT-s-OFDM P1/2 BPSK Edge 1RB Right	22.66	17.51	0.0564
	133600	15KHZ 133600 DFT-s-OFDM P1/2 BPSK Outer Full	22.83	17.68	0.0586
	133600	15KHZ 133600 DFT-s-OFDM QPSK Edge 1RB Left	22.38	17.23	0.0528
	133600	15KHZ 133600 DFT-s-OFDM QPSK Edge 1RB Right	22.19	17.04	0.0506
	133600	15KHZ 133600 DFT-s-OFDM QPSK Outer Full	22.29	17.14	0.0518
	133600	15KHZ 133600 DFT-s-OFDM 16QAM Inner Full	22.42	17.27	0.0533
	133600	15KHZ 133600 DFT-s-OFDM 16QAM Edge 1RB Left	21.31	16.16	0.0413
	133600	15KHZ 133600 DFT-s-OFDM 16QAM Edge 1RB Right	21.18	16.03	0.0401
	133600	15KHZ 133600 DFT-s-OFDM 16QAM Outer Full	21.34	16.19	0.0416
	133600	15KHZ 133600 DFT-s-OFDM 64QAM Edge 1RB Left	20.71	15.56	0.0360
	133600	15KHZ 133600 DFT-s-OFDM 64QAM Edge 1RB Right	20.49	15.34	0.0342
	133600	15KHZ 133600 DFT-s-OFDM 64QAM Outer Full	20.77	15.62	0.0365
	133600	15KHZ 133600 DFT-s-OFDM 256QAM Edge 1RB Left	18.41	13.26	0.0212
	133600	15KHZ 133600 DFT-s-OFDM 256QAM Edge 1RB Right	18.16	13.01	0.0200
	133600	15KHZ 133600 DFT-s-OFDM 256QAM Outer Full	18.86	13.71	0.0235
	133600	15KHZ 133600 CP-OFDM QPSK Inner Full	21.47	16.32	0.0429
	133600	15KHZ 133600 CP-OFDM QPSK Edge 1RB Left	20.72	15.57	0.0361
	133600	15KHZ 133600 CP-OFDM QPSK Edge 1RB Right	20.15	15.00	0.0316
	133600	15KHZ 133600 CP-OFDM QPSK Outer Full	20.22	15.07	0.0321
	133600	15KHZ 133600 CP-OFDM 16QAM Inner Full	21.42	16.27	0.0424
	133600	15KHZ 133600 CP-OFDM 16QAM Edge 1RB Left	20.51	15.36	0.0344
	133600	15KHZ 133600 CP-OFDM 16QAM Edge 1RB Right	20.32	15.17	0.0329
	133600	15KHZ 133600 CP-OFDM 16QAM Outer Full	20.35	15.20	0.0331
	133600	15KHZ 133600 CP-OFDM 64QAM Edge 1RB Left	19.83	14.68	0.0294
	133600	15KHZ 133600 CP-OFDM 64QAM Edge 1RB Right	19.5	14.35	0.0272
	133600	15KHZ 133600 CP-OFDM 64QAM Outer Full	19.89	14.74	0.0298
	133600	15KHZ 133600 CP-OFDM 256QAM Edge 1RB Left	16.4	11.25	0.0133
	133600	15KHZ 133600 CP-OFDM 256QAM Edge 1RB Right	15.99	10.84	0.0121
	133600	15KHZ 133600 CP-OFDM 256QAM Outer Full	16.97	11.82	0.0152
	136100	15KHZ 136100 DFT-s-OFDM P1/2 BPSK Inner 1RB Right	23.61	18.46	0.0701
	136100	15KHZ 136100 DFT-s-OFDM P1/2 BPSK Inner 1RB Left	22.23	17.08	0.0511
	136100	15KHZ 136100 DFT-s-OFDM P1/2 BPSK Inner Full	23.52	18.37	0.0687
	136100	15KHZ 136100 DFT-s-OFDM P1/2 BPSK Inner Full	22.39	17.24	0.0530
	136100	15KHZ 136100 DFT-s-OFDM P1/2 BPSK Inner Full	22.47	17.32	0.0540
	136100	15KHZ 136100 DFT-s-OFDM QPSK Inner 1RB Right	23.43	18.28	0.0673
	136100	15KHZ 136100 DFT-s-OFDM QPSK Inner 1RB Left	23.26	18.11	0.0647
	136100	15KHZ 136100 DFT-s-OFDM QPSK Inner Full	23.35	18.20	0.0661
	136100	15KHZ 136100 DFT-s-OFDM P1/2 BPSK Inner Full	23.65	18.50	0.0708
	136100	15KHZ 136100 DFT-s-OFDM P1/2 BPSK Edge 1RB Left	22.72	17.57	0.0571
	136100	15KHZ 136100 DFT-s-OFDM P1/2 BPSK Edge 1RB Right	23.02	17.87	0.0612
	136100	15KHZ 136100 DFT-s-OFDM P1/2 BPSK Outer Full	22.92	17.77	0.0598
	136100	15KHZ 136100 DFT-s-OFDM QPSK Inner Full	23.36	18.21	0.0662
	136100	15KHZ 136100 DFT-s-OFDM QPSK Edge 1RB Left	22.35	17.20	0.0525
	136100	15KHZ 136100 DFT-s-OFDM QPSK Edge 1RB Right	22.42	17.27	0.0533
	136100	15KHZ 136100 DFT-s-OFDM QPSK Outer Full	22.36	17.21	0.0526
	136100	15KHZ 136100 DFT-s-OFDM 16QAM Inner Full	22.3	17.15	0.0519
	136100	15KHZ 136100 DFT-s-OFDM 16QAM Edge 1RB Left	21.25	16.10	0.0407
	136100	15KHZ 136100 DFT-s-OFDM 16QAM Edge 1RB Right	21.63	16.48	0.0445
	136100	15KHZ 136100 DFT-s-OFDM 16QAM Outer Full	21.5	16.35	0.0432
	136100	15KHZ 136100 DFT-s-OFDM 64QAM Edge 1RB Left	20.75	15.60	0.0363
	136100	15KHZ 136100 DFT-s-OFDM 64QAM Edge 1RB Right	20.51	15.36	0.0344
	136100	15KHZ 136100 DFT-s-OFDM 64QAM Outer Full	20.92	15.77	0.0378
	136100	15KHZ 136100 DFT-s-OFDM 256QAM Edge 1RB Left	18.16	13.01	0.0200
	136100	15KHZ 136100 DFT-s-OFDM 256QAM Edge 1RB Right	18.27	13.12	0.0205
	136100	15KHZ 136100 DFT-s-OFDM 256QAM Outer Full	18.81	13.66	0.0232
	136100	15KHZ 136100 CP-OFDM QPSK Inner Full	21.85	16.70	0.0468
	136100	15KHZ 136100 CP-OFDM QPSK Edge 1RB Left	20.25	15.10	0.0324
	136100	15KHZ 136100 CP-OFDM QPSK Edge 1RB Right	20.53	15.38	0.0345
	136100	15KHZ 136100 CP-OFDM QPSK Outer Full	20.34	15.19	0.0330
	136100	15KHZ 136100 CP-OFDM 16QAM Inner Full	21.13	15.98	0.0396
	136100	15KHZ 136100 CP-OFDM 16QAM Edge 1RB Left	20.53	15.38	0.0345
	136100	15KHZ 136100 CP-OFDM 16QAM Edge 1RB Right	20.56	15.41	0.0348
	136100	15KHZ 136100 CP-OFDM 16QAM Outer Full	20.35	15.20	0.0331
	136100	15KHZ 136100 CP-OFDM 64QAM Edge 1RB Left	19.49	14.34	0.0272
	136100	15KHZ 136100 CP-OFDM 64QAM Edge 1RB Right	19.74	14.59	0.0288
	136100	15KHZ 136100 CP-OFDM 64QAM Outer Full	19.81	14.66	0.0292
	136100	15KHZ 136100 CP-OFDM 256QAM Edge 1RB Left	16.16	11.01	0.0126
	136100	15KHZ 136100 CP-OFDM 256QAM Edge 1RB Right	16.2	11.05	0.0127
	136100	15KHZ 136100 CP-OFDM 256QAM Outer Full	16.82	11.67	0.0147
	138600	15KHZ 138600 DFT-s-OFDM P1/2 BPSK Inner 1RB Right	22.2	17.05	0.0507
	138600	15KHZ 138600 DFT-s-OFDM P1/2 BPSK Inner 1RB Left	22.38	17.23	0.0528
	138600	15KHZ 138600 DFT-s-OFDM P1/2 BPSK Inner Full	22.31	17.16	0.0520
	138600	15KHZ 138600 DFT-s-OFDM QPSK Inner 1RB Right	22.1	16.95	0.0495
	138600	15KHZ 138600 DFT-s-OFDM QPSK Inner 1RB Left	23.48	18.33	0.0681
	138600	15KHZ 138600 DFT-s-OFDM QPSK Inner Full	23.34	18.19	0.0659
	138600	15KHZ 138600 DFT-s-OFDM P1/2 BPSK Inner Full	23.25	18.10	0.0646
	138600	15KHZ 138600 DFT-s-OFDM P1/2 BPSK Edge 1RB Left	22.91	17.76	0.0597
	138600	15KHZ 138600 DFT-s-OFDM P1/2 BPSK Edge 1RB Right	22.62	17.47	0.0558
	138600	15KHZ 138600 DFT-s-OFDM P1/2 BPSK Outer Full	22.8	17.65	0.0582
	138600	15KHZ 138600 DFT-s-OFDM QPSK Inner Full	23.44	18.29	0.0675
	138600	15KHZ 138600 DFT-s-OFDM QPSK Edge 1RB Left	22.39	17.24	0.0530
	138600	15KHZ 138600 DFT-s-OFDM QPSK Edge 1RB Right	22.1	16.95	0.0495
	138600	15KHZ 138600 DFT-s-OFDM QPSK Outer Full	22.3	17.15	0.0519
	138600	15KHZ 138600 DFT-s-OFDM 16QAM Inner Full	22.4	17.25	0.0531
	138600	15KHZ 138600 DFT-s-OFDM 16QAM Edge 1RB Left	21.31	16.16	0.0413
	138600	15KHZ 138600 DFT-s-OFDM 16QAM Edge 1RB Right	21.07	15.92	0.0391
	138600	15KHZ 138600 DFT-s-OFDM 16QAM Outer Full	21.29	16.14	0.0411
	138600	15KHZ 138600 DFT-s-OFDM 64QAM Edge 1RB Left	20.56	15.41	0.0348
	138600	15KHZ 138600 DFT-s-OFDM 64QAM Edge 1RB Right	20.49	15.34	0.0342
	138600	15KHZ 138600 DFT-s-OFDM 64QAM Outer Full	20.75	15.60	0.0363
	138600	15KHZ 138600 DFT-s-OFDM 256QAM Edge 1RB Left	18.32	13.17	0.0207
	138600	15KHZ 138600 DFT-s-OFDM 256QAM Edge 1RB Right	18.23	13.08	0.0203
	138600	15KHZ 138600 DFT-s-OFDM 256QAM Outer Full	18.71	13.56	0.0227
	138600	15KHZ 138600 CP-OFDM QPSK Inner Full	21.78	16.63	0.0460
	138600	15KHZ 138600 CP-OFDM QPSK Edge 1RB Left	20.34	15.19	0.0330
	138600	15KHZ 138600 CP-OFDM QPSK Edge 1RB Right	20.1	14.95	0.0313
	138600	15KHZ 138600 CP-OFDM QPSK Outer Full	20.18	15.03	0.0318
	138600	15KHZ 138600 CP-OFDM 16QAM Inner Full	21.49	16.34	0.0431
	138600	15KHZ 138600 CP-OFDM 16QAM Edge 1RB Left	20.49	15.34	0.0342
	138600	15KHZ 138600 CP-OFDM 16QAM Edge 1RB Right	20.23	15.08	0.0322
	138600	15KHZ 138600 CP-OFDM 16QAM Outer Full	20.22	15.07	0.0321
	138600	15KHZ 138600 CP-OFDM 64QAM Edge 1RB Left	19.67	14.52	0.0283
	138600	15KHZ 138600 CP-OFDM 64QAM Edge 1RB Right	19.36	14.21	0.0264
	138600	15KHZ 138600 CP-OFDM 64QAM Outer Full	19.77	14.62	0.0290
	138600	15KHZ 138600 CP-OFDM 256QAM Edge 1RB Left	16.16	11.01	0.0126
	138600	15KHZ 138600 CP-OFDM 256QAM Edge 1RB Right	16.04	10.89	0.0123
	138600	15KHZ 138600 CP-OFDM 256QAM Outer Full	16.87	11.72	0.0149

5G NR n71- 15MHZ	Channel	TestItem	MeasuredValue	EIRP power (dbm)	EIRP power (W)
	134100	15KHZ 134100 DFT-s-OFDM P1/2 BPSK Inner 1RB Right	22.3	17.15	0.0519
	134100	15KHZ 134100 DFT-s-OFDM P1/2 BPSK Inner 1RB Left	23.34	18.19	0.0659
	134100	15KHZ 134100 DFT-s-OFDM P1/2 BPSK Inner Full	23.23	18.08	0.0643
	134100	15KHZ 134100 DFT-s-OFDM QPSK Inner 1RB Right	23	17.85	0.0610
	134100	15KHZ 134100 DFT-s-OFDM QPSK Inner 1RB Left	23.31	18.16	0.0655
	134100	15KHZ 134100 DFT-s-OFDM QPSK Inner Full	22.27	17.12	0.0515
	134100	15KHZ 134100 DFT-s-OFDM P1/2 BPSK Inner Full	23.2	18.05	0.0638
	134100	15KHZ 134100 DFT-s-OFDM P1/2 BPSK Edge 1RB Left	22.88	17.73	0.0593
	134100	15KHZ 134100 DFT-s-OFDM P1/2 BPSK Edge 1RB Right	22.74	17.59	0.0574
	134100	15KHZ 134100 DFT-s-OFDM P1/2 BPSK Outer Full	22.73	17.58	0.0573
	134100	15KHZ 134100 DFT-s-OFDM QPSK Edge 1RB Left	22.32	17.17	0.0521
	134100	15KHZ 134100 DFT-s-OFDM QPSK Edge 1RB Right	22.09	16.94	0.0494
	134100	15KHZ 134100 DFT-s-OFDM QPSK Outer Full	22.28	17.13	0.0516
	134100	15KHZ 134100 DFT-s-OFDM 16QAM Inner Full	22.25	17.10	0.0513
	134100	15KHZ 134100 DFT-s-OFDM 16QAM Edge 1RB Left	21.44	16.29	0.0426
	134100	15KHZ 134100 DFT-s-OFDM 16QAM Edge 1RB Right	21.08	15.93	0.0392
	134100	15KHZ 134100 DFT-s-OFDM 16QAM Outer Full	21.22	16.07	0.0405
	134100	15KHZ 134100 DFT-s-OFDM 64QAM Edge 1RB Left	20.61	15.46	0.0352
	134100	15KHZ 134100 DFT-s-OFDM 64QAM Edge 1RB Right	20.33	15.18	0.0330
	134100	15KHZ 134100 DFT-s-OFDM 64QAM Outer Full	20.88	15.73	0.0374
	134100	15KHZ 134100 DFT-s-OFDM 256QAM Edge 1RB Left	18.52	13.37	0.0217
	134100	15KHZ 134100 DFT-s-OFDM 256QAM Edge 1RB Right	18.28	13.13	0.0206
	134100	15KHZ 134100 DFT-s-OFDM 256QAM Outer Full	18.86	13.71	0.0235
	134100	15KHZ 134100 CP-OFDM QPSK Inner Full	21.66	16.51	0.0448
	134100	15KHZ 134100 CP-OFDM QPSK Edge 1RB Left	20.73	15.58	0.0361
	134100	15KHZ 134100 CP-OFDM QPSK Edge 1RB Right	20.06	14.91	0.0310
	134100	15KHZ 134100 CP-OFDM QPSK Outer Full	20.19	15.04	0.0319
	134100	15KHZ 134100 CP-OFDM 16QAM Inner Full	20.98	15.83	0.0383
	134100	15KHZ 134100 CP-OFDM 16QAM Edge 1RB Left	20.58	15.43	0.0349
	134100	15KHZ 134100 CP-OFDM 16QAM Edge 1RB Right	20.2	15.05	0.0320
	134100	15KHZ 134100 CP-OFDM 16QAM Outer Full	20.27	15.12	0.0325
	134100	15KHZ 134100 CP-OFDM 64QAM Edge 1RB Left	19.88	14.73	0.0297
	134100	15KHZ 134100 CP-OFDM 64QAM Edge 1RB Right	19.68	14.53	0.0284
	134100	15KHZ 134100 CP-OFDM 64QAM Outer Full	19.98	14.83	0.0304
	134100	15KHZ 134100 CP-OFDM 256QAM Edge 1RB Left	16.34	11.19	0.0132
	134100	15KHZ 134100 CP-OFDM 256QAM Edge 1RB Right	16.06	10.91	0.0123
	134100	15KHZ 134100 CP-OFDM 256QAM Outer Full	16.92	11.77	0.0150
	136100	15KHZ 136100 DFT-s-OFDM P1/2 BPSK Inner 1RB Right	22.65	17.50	0.0562
	136100	15KHZ 136100 DFT-s-OFDM P1/2 BPSK Inner 1RB Left	22.49	17.34	0.0542
	136100	15KHZ 136100 DFT-s-OFDM P1/2 BPSK Inner Full	23.55	18.40	0.0692
	136100	15KHZ 136100 DFT-s-OFDM P1/2 BPSK Inner Full	22.35	17.20	0.0525
	136100	15KHZ 136100 DFT-s-OFDM P1/2 BPSK Inner Full	22.46	17.31	0.0538
	136100	15KHZ 136100 DFT-s-OFDM QPSK Inner 1RB Right	22.53	17.38	0.0547
	136100	15KHZ 136100 DFT-s-OFDM QPSK Inner 1RB Left	22.33	17.18	0.0522
	136100	15KHZ 136100 DFT-s-OFDM QPSK Inner Full	23.44	18.29	0.0675
	136100	15KHZ 136100 DFT-s-OFDM P1/2 BPSK Inner Full	23.33	18.18	0.0658
	136100	15KHZ 136100 DFT-s-OFDM P1/2 BPSK Edge 1RB Left	22.83	17.68	0.0586
	136100	15KHZ 136100 DFT-s-OFDM P1/2 BPSK Edge 1RB Right	23.06	17.91	0.0618
	136100	15KHZ 136100 DFT-s-OFDM P1/2 BPSK Outer Full	22.93	17.78	0.0600
	136100	15KHZ 136100 DFT-s-OFDM QPSK Inner Full	23.34	18.19	0.0659
	136100	15KHZ 136100 DFT-s-OFDM QPSK Edge 1RB Left	22.24	17.09	0.0512
	136100	15KHZ 136100 DFT-s-OFDM QPSK Edge 1RB Right	22.38	17.23	0.0528
	136100	15KHZ 136100 DFT-s-OFDM QPSK Outer Full	22.38	17.23	0.0528
	136100	15KHZ 136100 DFT-s-OFDM 16QAM Inner Full	22.34	17.19	0.0524
	136100	15KHZ 136100 DFT-s-OFDM 16QAM Edge 1RB Left	21.37	16.22	0.0419
	136100	15KHZ 136100 DFT-s-OFDM 16QAM Edge 1RB Right	21.56	16.41	0.0438
	136100	15KHZ 136100 DFT-s-OFDM 16QAM Outer Full	21.39	16.24	0.0421
	136100	15KHZ 136100 DFT-s-OFDM 64QAM Edge 1RB Left	20.68	15.53	0.0357
	136100	15KHZ 136100 DFT-s-OFDM 64QAM Edge 1RB Right	20.72	15.57	0.0361
	136100	15KHZ 136100 DFT-s-OFDM 64QAM Outer Full	20.93	15.78	0.0378
	136100	15KHZ 136100 DFT-s-OFDM 256QAM Edge 1RB Left	18.26	13.11	0.0205
	136100	15KHZ 136100 DFT-s-OFDM 256QAM Edge 1RB Right	18.34	13.19	0.0208
	136100	15KHZ 136100 DFT-s-OFDM 256QAM Outer Full	18.82	13.67	0.0233
	136100	15KHZ 136100 CP-OFDM QPSK Inner Full	21.85	16.70	0.0468
	136100	15KHZ 136100 CP-OFDM QPSK Edge 1RB Left	20.34	15.19	0.0330
	136100	15KHZ 136100 CP-OFDM QPSK Edge 1RB Right	20.45	15.30	0.0339
	136100	15KHZ 136100 CP-OFDM QPSK Outer Full	20.26	15.11	0.0324
	136100	15KHZ 136100 CP-OFDM 16QAM Inner Full	21.36	16.21	0.0418
	136100	15KHZ 136100 CP-OFDM 16QAM Edge 1RB Left	20.35	15.20	0.0331
	136100	15KHZ 136100 CP-OFDM 16QAM Edge 1RB Right	20.52	15.37	0.0344
	136100	15KHZ 136100 CP-OFDM 16QAM Outer Full	20.37	15.22	0.0333
	136100	15KHZ 136100 CP-OFDM 64QAM Edge 1RB Left	19.51	14.36	0.0273
	136100	15KHZ 136100 CP-OFDM 64QAM Edge 1RB Right	20.13	14.98	0.0315
	136100	15KHZ 136100 CP-OFDM 64QAM Outer Full	19.78	14.63	0.0290
	136100	15KHZ 136100 CP-OFDM 256QAM Edge 1RB Left	16.28	11.13	0.0130
	136100	15KHZ 136100 CP-OFDM 256QAM Edge 1RB Right	16.2	11.05	0.0127
	136100	15KHZ 136100 CP-OFDM 256QAM Outer Full	16.86	11.71	0.0148
	138100	15KHZ 138100 DFT-s-OFDM P1/2 BPSK Inner 1RB Right	23.01	17.86	0.0611
	138100	15KHZ 138100 DFT-s-OFDM P1/2 BPSK Inner 1RB Left	22.2	17.05	0.0507
	138100	15KHZ 138100 DFT-s-OFDM P1/2 BPSK Inner Full	23.44	18.29	0.0675
	138100	15KHZ 138100 DFT-s-OFDM QPSK Inner 1RB Right	22.05	16.90	0.0490
	138100	15KHZ 138100 DFT-s-OFDM QPSK Inner 1RB Left	23.28	18.13	0.0650
	138100	15KHZ 138100 DFT-s-OFDM QPSK Inner Full	22.29	17.14	0.0518
	138100	15KHZ 138100 DFT-s-OFDM P1/2 BPSK Inner Full	23.37	18.22	0.0664
	138100	15KHZ 138100 DFT-s-OFDM P1/2 BPSK Edge 1RB Left	22.8	17.65	0.0582
	138100	15KHZ 138100 DFT-s-OFDM P1/2 BPSK Edge 1RB Right	22.57	17.42	0.0552
	138100	15KHZ 138100 DFT-s-OFDM P1/2 BPSK Outer Full	22.8	17.65	0.0582
	138100	15KHZ 138100 DFT-s-OFDM QPSK Inner Full	23.42	18.27	0.0671
	138100	15KHZ 138100 DFT-s-OFDM QPSK Edge 1RB Left	22.25	17.10	0.0513
	138100	15KHZ 138100 DFT-s-OFDM QPSK Edge 1RB Right	21.98	16.83	0.0482
	138100	15KHZ 138100 DFT-s-OFDM QPSK Outer Full	22.37	17.22	0.0527
	138100	15KHZ 138100 DFT-s-OFDM 16QAM Inner Full	22.35	17.20	0.0525
	138100	15KHZ 138100 DFT-s-OFDM 16QAM Edge 1RB Left	21.33	16.18	0.0415
	138100	15KHZ 138100 DFT-s-OFDM 16QAM Edge 1RB Right	21.06	15.91	0.0390
	138100	15KHZ 138100 DFT-s-OFDM 16QAM Outer Full	21.42	16.27	0.0424
	138100	15KHZ 138100 DFT-s-OFDM 64QAM Edge 1RB Left	20.73	15.58	0.0361
	138100	15KHZ 138100 DFT-s-OFDM 64QAM Edge 1RB Right	20.46	15.31	0.0340
	138100	15KHZ 138100 DFT-s-OFDM 64QAM Outer Full	20.85	15.70	0.0372
	138100	15KHZ 138100 DFT-s-OFDM 256QAM Edge 1RB Left	18.32	13.17	0.0207
	138100	15KHZ 138100 DFT-s-OFDM 256QAM Edge 1RB Right	18.25	13.10	0.0204
	138100	15KHZ 138100 DFT-s-OFDM 256QAM Outer Full	18.83	13.68	0.0233
	138100	15KHZ 138100 CP-OFDM QPSK Inner Full	21.43	16.28	0.0425
	138100	15KHZ 138100 CP-OFDM QPSK Edge 1RB Left	20.53	15.38	0.0345
	138100	15KHZ 138100 CP-OFDM QPSK Edge 1RB Right	20.35	15.20	0.0331
	138100	15KHZ 138100 CP-OFDM QPSK Outer Full	20.26	15.11	0.0324
	138100	15KHZ 138100 CP-OFDM 16QAM Inner Full	21.11	15.96	0.0394
	138100	15KHZ 138100 CP-OFDM 16QAM Edge 1RB Left	20.41	15.26	0.0336
	138100	15KHZ 138100 CP-OFDM 16QAM Edge 1RB Right	20.2	15.05	0.0320
	138100	15KHZ 138100 CP-OFDM 16QAM Outer Full	20.34	15.19	0.0330
	138100	15KHZ 138100 CP-OFDM 64QAM Edge 1RB Left	19.6	14.45	0.0279
	138100	15KHZ 138100 CP-OFDM 64QAM Edge 1RB Right	19.34	14.19	0.0262
	138100	15KHZ 138100 CP-OFDM 64QAM Outer Full	19.94	14.79	0.0301
	138100	15KHZ 138100 CP-OFDM 256QAM Edge 1RB Left	16.29	11.14	0.0130
	138100	15KHZ 138100 CP-OFDM 256QAM Edge 1RB Right	16.23	11.08	0.0128
	138100	15KHZ 138100 CP-OFDM 256QAM Outer Full	16.9	11.75	0.0150

5G NR n71- 20MHZ	Channel	TestItem	MeasuredValue	EIRP power (dbm)	EIRP power (W)
	134600	15KHZ 134600 DFT-s-OFDM P1/2 BPSK Inner 1RB Right	23.4	18.25	0.0668
	134600	15KHZ 134600 DFT-s-OFDM P1/2 BPSK Inner 1RB Left	23.92	18.77	0.0753
	134600	15KHZ 134600 DFT-s-OFDM P1/2 BPSK Inner Full	23.3	18.15	0.0653
	134600	15KHZ 134600 DFT-s-OFDM QPSK Inner 1RB Right	23.22	18.07	0.0641
	134600	15KHZ 134600 DFT-s-OFDM QPSK Inner 1RB Left	22.49	17.34	0.0542
	134600	15KHZ 134600 DFT-s-OFDM QPSK Inner Full	23.47	18.32	0.0679
	134600	15KHZ 134600 DFT-s-OFDM P1/2 BPSK Inner Full	23.5	18.35	0.0684
	134600	15KHZ 134600 DFT-s-OFDM P1/2 BPSK Edge 1RB Left	22.9	17.75	0.0596
	134600	15KHZ 134600 DFT-s-OFDM P1/2 BPSK Edge 1RB Right	22.74	17.59	0.0574
	134600	15KHZ 134600 DFT-s-OFDM P1/2 BPSK Outer Full	22.8	17.65	0.0582
	134600	15KHZ 134600 DFT-s-OFDM QPSK Edge 1RB Left	22.4	17.25	0.0531
	134600	15KHZ 134600 DFT-s-OFDM QPSK Edge 1RB Right	22.3	17.15	0.0519
	134600	15KHZ 134600 DFT-s-OFDM QPSK Outer Full	22.34	17.19	0.0524
	134600	15KHZ 134600 DFT-s-OFDM 16QAM Inner Full	22.34	17.19	0.0524
	134600	15KHZ 134600 DFT-s-OFDM 16QAM Edge 1RB Left	21.33	16.18	0.0415
	134600	15KHZ 134600 DFT-s-OFDM 16QAM Edge 1RB Right	21.26	16.11	0.0408
	134600	15KHZ 134600 DFT-s-OFDM 16QAM Outer Full	21.36	16.21	0.0418
	134600	15KHZ 134600 DFT-s-OFDM 64QAM Edge 1RB Left	20.82	15.67	0.0369
	134600	15KHZ 134600 DFT-s-OFDM 64QAM Edge 1RB Right	20.34	15.19	0.0330
	134600	15KHZ 134600 DFT-s-OFDM 64QAM Outer Full	20.88	15.73	0.0374
	134600	15KHZ 134600 DFT-s-OFDM 256QAM Edge 1RB Left	18.43	13.28	0.0213
	134600	15KHZ 134600 DFT-s-OFDM 256QAM Edge 1RB Right	18.26	13.11	0.0205
	134600	15KHZ 134600 DFT-s-OFDM 256QAM Outer Full	18.86	13.71	0.0235
	134600	15KHZ 134600 CP-OFDM QPSK Inner Full	21.78	16.63	0.0460
	134600	15KHZ 134600 CP-OFDM QPSK Edge 1RB Left	20.78	15.63	0.0366
	134600	15KHZ 134600 CP-OFDM QPSK Edge 1RB Right	20.3	15.15	0.0327
	134600	15KHZ 134600 CP-OFDM QPSK Outer Full	20.27	15.12	0.0325
	134600	15KHZ 134600 CP-OFDM 16QAM Inner Full	21.33	16.18	0.0415
	134600	15KHZ 134600 CP-OFDM 16QAM Edge 1RB Left	20.54	15.39	0.0346
	134600	15KHZ 134600 CP-OFDM 16QAM Edge 1RB Right	20.28	15.13	0.0326
	134600	15KHZ 134600 CP-OFDM 16QAM Outer Full	20.31	15.16	0.0328
	134600	15KHZ 134600 CP-OFDM 64QAM Edge 1RB Left	19.85	14.70	0.0295
	134600	15KHZ 134600 CP-OFDM 64QAM Edge 1RB Right	19.49	14.34	0.0272
	134600	15KHZ 134600 CP-OFDM 64QAM Outer Full	19.84	14.69	0.0294
	134600	15KHZ 134600 CP-OFDM 256QAM Edge 1RB Left	16.49	11.34	0.0136
	134600	15KHZ 134600 CP-OFDM 256QAM Edge 1RB Right	16.11	10.96	0.0125
	134600	15KHZ 134600 CP-OFDM 256QAM Outer Full	16.85	11.70	0.0148
	136100	15KHZ 136100 DFT-s-OFDM P1/2 BPSK Inner 1RB Right	23.65	18.50	0.0708
	136100	15KHZ 136100 DFT-s-OFDM P1/2 BPSK Inner 1RB Left	23.45	18.30	0.0676
	136100	15KHZ 136100 DFT-s-OFDM P1/2 BPSK Inner Full	23.32	18.17	0.0656
	136100	15KHZ 136100 DFT-s-OFDM P1/2 BPSK Inner Full	23.64	18.49	0.0706
	136100	15KHZ 136100 DFT-s-OFDM P1/2 BPSK Inner Full	23.62	18.47	0.0703
	136100	15KHZ 136100 DFT-s-OFDM QPSK Inner 1RB Right	23.39	18.24	0.0667
	136100	15KHZ 136100 DFT-s-OFDM QPSK Inner 1RB Left	23.3	18.15	0.0653
	136100	15KHZ 136100 DFT-s-OFDM QPSK Inner Full	23.42	18.27	0.0671
	136100	15KHZ 136100 DFT-s-OFDM P1/2 BPSK Inner Full	23.6	18.45	0.0700
	136100	15KHZ 136100 DFT-s-OFDM P1/2 BPSK Edge 1RB Left	22.82	17.67	0.0585
	136100	15KHZ 136100 DFT-s-OFDM P1/2 BPSK Edge 1RB Right	23.02	17.87	0.0612
	136100	15KHZ 136100 DFT-s-OFDM P1/2 BPSK Outer Full	22.91	17.76	0.0597
	136100	15KHZ 136100 DFT-s-OFDM QPSK Inner Full	23.43	18.28	0.0673
	136100	15KHZ 136100 DFT-s-OFDM QPSK Edge 1RB Left	22.3	17.15	0.0519
	136100	15KHZ 136100 DFT-s-OFDM QPSK Edge 1RB Right	22.48	17.33	0.0541
	136100	15KHZ 136100 DFT-s-OFDM QPSK Outer Full	22.41	17.26	0.0532
	136100	15KHZ 136100 DFT-s-OFDM 16QAM Inner Full	22.38	17.23	0.0528
	136100	15KHZ 136100 DFT-s-OFDM 16QAM Edge 1RB Left	21.22	16.07	0.0405
	136100	15KHZ 136100 DFT-s-OFDM 16QAM Edge 1RB Right	21.46	16.31	0.0428
	136100	15KHZ 136100 DFT-s-OFDM 16QAM Outer Full	21.47	16.32	0.0429
	136100	15KHZ 136100 DFT-s-OFDM 64QAM Edge 1RB Left	20.74	15.59	0.0362
	136100	15KHZ 136100 DFT-s-OFDM 64QAM Edge 1RB Right	20.65	15.50	0.0355
	136100	15KHZ 136100 DFT-s-OFDM 64QAM Outer Full	20.88	15.73	0.0374
	136100	15KHZ 136100 DFT-s-OFDM 256QAM Edge 1RB Left	18.28	13.13	0.0206
	136100	15KHZ 136100 DFT-s-OFDM 256QAM Edge 1RB Right	18.3	13.15	0.0207
	136100	15KHZ 136100 DFT-s-OFDM 256QAM Outer Full	18.84	13.69	0.0234
	136100	15KHZ 136100 CP-OFDM QPSK Inner Full	21.54	16.39	0.0436
	136100	15KHZ 136100 CP-OFDM QPSK Edge 1RB Left	20.64	15.49	0.0354
	136100	15KHZ 136100 CP-OFDM QPSK Edge 1RB Right	20.42	15.27	0.0337
	136100	15KHZ 136100 CP-OFDM QPSK Outer Full	20.44	15.29	0.0338
	136100	15KHZ 136100 CP-OFDM 16QAM Inner Full	21.45	16.30	0.0427
	136100	15KHZ 136100 CP-OFDM 16QAM Edge 1RB Left	20.42	15.27	0.0337
	136100	15KHZ 136100 CP-OFDM 16QAM Edge 1RB Right	20.36	15.21	0.0332
	136100	15KHZ 136100 CP-OFDM 16QAM Outer Full	20.39	15.24	0.0334
	136100	15KHZ 136100 CP-OFDM 64QAM Edge 1RB Left	19.57	14.42	0.0277
	136100	15KHZ 136100 CP-OFDM 64QAM Edge 1RB Right	19.64	14.49	0.0281
	136100	15KHZ 136100 CP-OFDM 64QAM Outer Full	19.94	14.79	0.0301
	136100	15KHZ 136100 CP-OFDM 256QAM Edge 1RB Left	16.41	11.26	0.0134
	136100	15KHZ 136100 CP-OFDM 256QAM Edge 1RB Right	16.22	11.07	0.0128
	136100	15KHZ 136100 CP-OFDM 256QAM Outer Full	16.9	11.75	0.0150
	137600	15KHZ 137600 DFT-s-OFDM P1/2 BPSK Inner 1RB Right	23.15	18.00	0.0631
	137600	15KHZ 137600 DFT-s-OFDM P1/2 BPSK Inner 1RB Left	23.29	18.14	0.0652
	137600	15KHZ 137600 DFT-s-OFDM P1/2 BPSK Inner Full	23.48	18.33	0.0681
	137600	15KHZ 137600 DFT-s-OFDM QPSK Inner 1RB Right	23.08	17.93	0.0621
	137600	15KHZ 137600 DFT-s-OFDM QPSK Inner 1RB Left	23.18	18.03	0.0635
	137600	15KHZ 137600 DFT-s-OFDM QPSK Inner Full	23.52	18.37	0.0687
	137600	15KHZ 137600 DFT-s-OFDM P1/2 BPSK Inner Full	23.59	18.44	0.0698
	137600	15KHZ 137600 DFT-s-OFDM P1/2 BPSK Edge 1RB Left	22.69	17.54	0.0568
	137600	15KHZ 137600 DFT-s-OFDM P1/2 BPSK Edge 1RB Right	22.55	17.40	0.0550
	137600	15KHZ 137600 DFT-s-OFDM P1/2 BPSK Outer Full	22.88	17.73	0.0593
	137600	15KHZ 137600 DFT-s-OFDM QPSK Inner Full	23.48	18.33	0.0681
	137600	15KHZ 137600 DFT-s-OFDM QPSK Edge 1RB Left	22.21	17.06	0.0508
	137600	15KHZ 137600 DFT-s-OFDM QPSK Edge 1RB Right	22.09	16.94	0.0494
	137600	15KHZ 137600 DFT-s-OFDM QPSK Outer Full	22.39	17.24	0.0530
	137600	15KHZ 137600 DFT-s-OFDM 16QAM Inner Full	22.47	17.32	0.0540
	137600	15KHZ 137600 DFT-s-OFDM 16QAM Edge 1RB Left	21.13	15.98	0.0396
	137600	15KHZ 137600 DFT-s-OFDM 16QAM Edge 1RB Right	21.07	15.92	0.0391
	137600	15KHZ 137600 DFT-s-OFDM 16QAM Outer Full	21.4	16.25	0.0422
	137600	15KHZ 137600 DFT-s-OFDM 64QAM Edge 1RB Left	20.66	15.51	0.0356
	137600	15KHZ 137600 DFT-s-OFDM 64QAM Edge 1RB Right	20.48	15.33	0.0341
	137600	15KHZ 137600 DFT-s-OFDM 64QAM Outer Full	20.93	15.78	0.0378
	137600	15KHZ 137600 DFT-s-OFDM 256QAM Edge 1RB Left	18.35	13.20	0.0209
	137600	15KHZ 137600 DFT-s-OFDM 256QAM Edge 1RB Right	18.08	12.93	0.0196
	137600	15KHZ 137600 DFT-s-OFDM 256QAM Outer Full	19.2	14.05	0.0254
	137600	15KHZ 137600 CP-OFDM QPSK Inner Full	21.92	16.77	0.0475
	137600	15KHZ 137600 CP-OFDM QPSK Edge 1RB Left	20.46	15.31	0.0340
	137600	15KHZ 137600 CP-OFDM QPSK Edge 1RB Right	20.18	15.03	0.0318
	137600	15KHZ 137600 CP-OFDM QPSK Outer Full	20.36	15.21	0.0332
	137600	15KHZ 137600 CP-OFDM 16QAM Inner Full	21.23	16.08	0.0406
	137600	15KHZ 137600 CP-OFDM 16QAM Edge 1RB Left	20.3	15.15	0.0327
	137600	15KHZ 137600 CP-OFDM 16QAM Edge 1RB Right	20.1	14.95	0.0313
	137600	15KHZ 137600 CP-OFDM 16QAM Outer Full	20.38	15.23	0.0333
	137600	15KHZ 137600 CP-OFDM 64QAM Edge 1RB Left	19.55	14.40	0.0275
	137600	15KHZ 137600 CP-OFDM 64QAM Edge 1RB Right	19.33	14.18	0.0262
	137600	15KHZ 137600 CP-OFDM 64QAM Outer Full	19.91	14.76	0.0299
	137600	15KHZ 137600 CP-OFDM 256QAM Edge 1RB Left	16.24	11.09	0.0129
	137600	15KHZ 137600 CP-OFDM 256QAM Edge 1RB Right	15.96	10.81	0.0121
	137600	15KHZ 137600 CP-OFDM 256QAM Outer Full	16.79	11.64	0.0146



5G NR n2

Peak-to-Average Ratio

Mode	N2 / 20MHz				
Mod.	QPSK		16QAM		Limit: 13dB
RB Size	1RB	Full RB	1RB	Full RB	Result
Lowest CH	3.80	4.20	4.58	5.42	PASS
Middle CH	4.00	4.20	4.96	5.39	
Highest CH	3.94	4.29	4.78	5.45	
Mode	N2 / 20MHz				
Mod.	64QAM		256QAM		Limit: 13dB
RB Size	1RB	Full RB	1RB	Full RB	Result
Lowest CH	5.45	5.86	6.84	6.38	PASS
Middle CH	7.33	5.86	7.33	6.38	
Highest CH	5.51	5.88	6.99	6.41	
Mode	N2 / 20MHz				
Mod.	BPSK				Limit: 13dB
RB Size	1RB	Full RB			Result
Lowest CH	4.09	3.42			PASS
Middle CH	4.32	3.48			
Highest CH	3.94	3.45			



N2 / 20MHz / BPSK

Lowest Channel / 1RB0

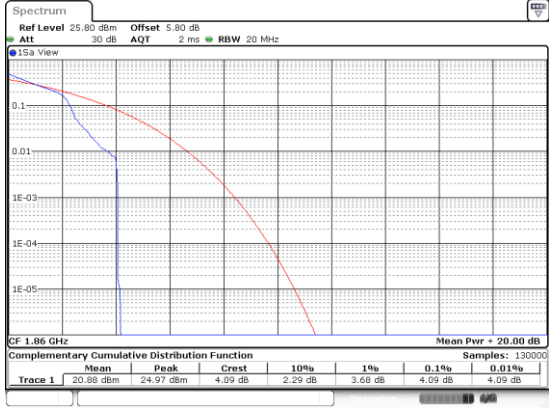

Lowest Channel / 100RB0

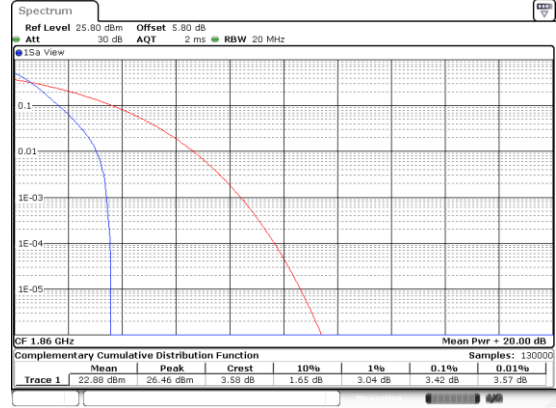

Middle Channel / 1RB0

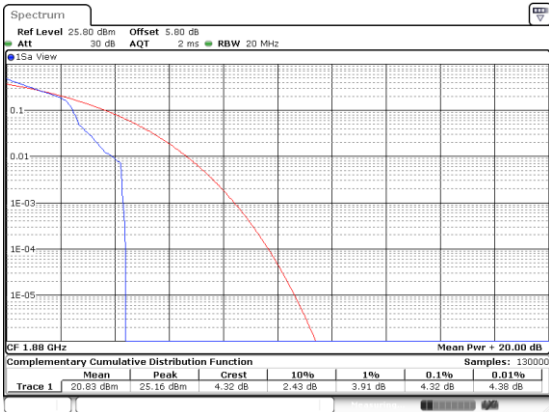

Middle Channel / 100RB0

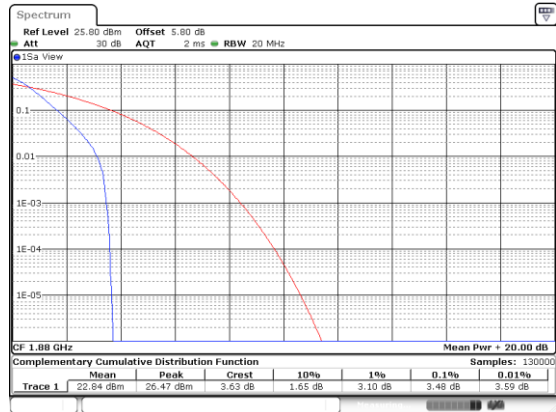

Highest Channel / 1RB0

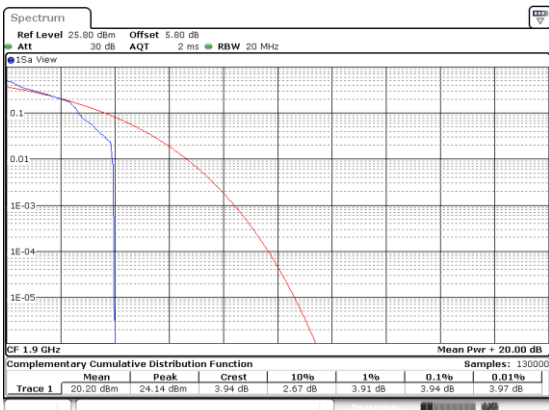

Highest Channel / 100RB0

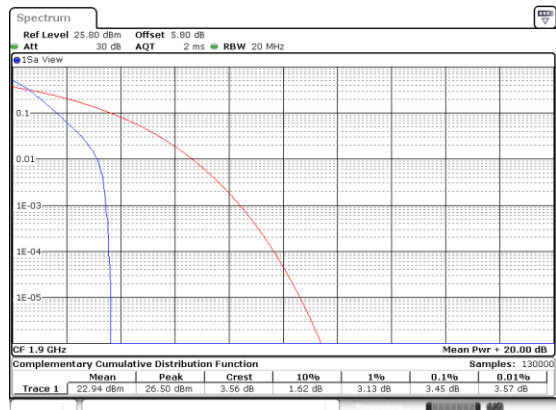



N2 / 20MHz / QPSK

Lowest Channel / 1RB0

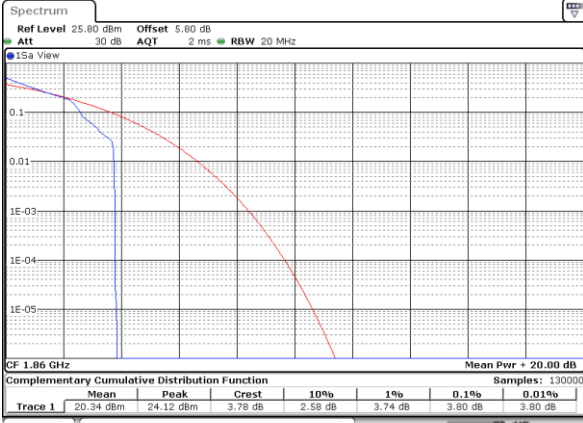

Date: 22 JUN 2020 23:55:38

Lowest Channel / 100RB0

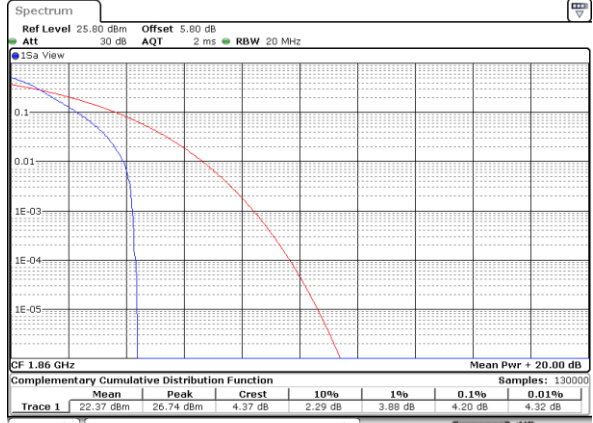

Date: 22 JUN 2020 23:50:07

Middle Channel / 1RB0

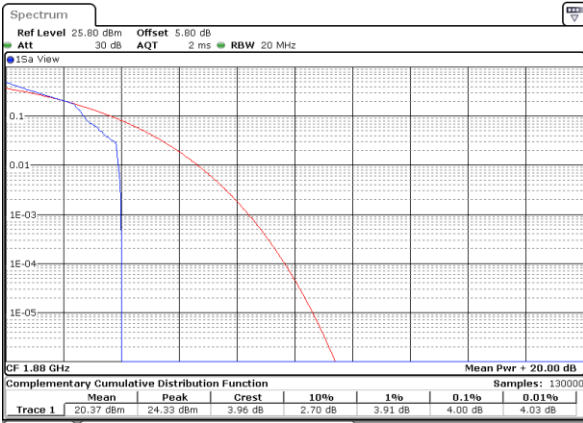

Date: 23 JUN 2020 00:11:56

Middle Channel / 100RB0

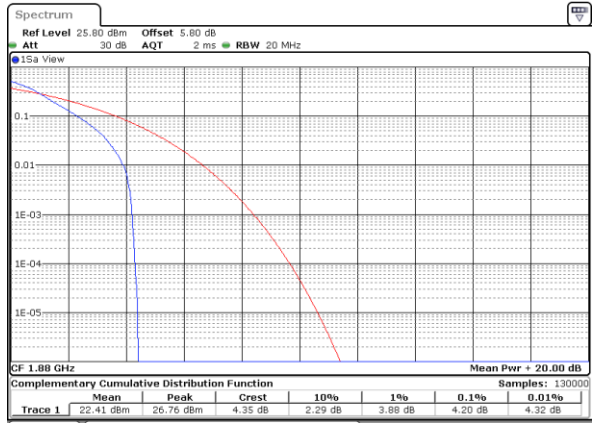

Date: 23 JUN 2020 00:24:28

Highest Channel / 1RB0

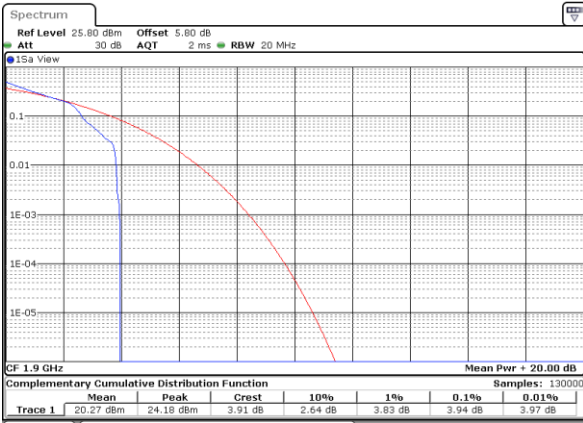

Date: 23 JUN 2020 00:34:39

Highest Channel / 100RB0

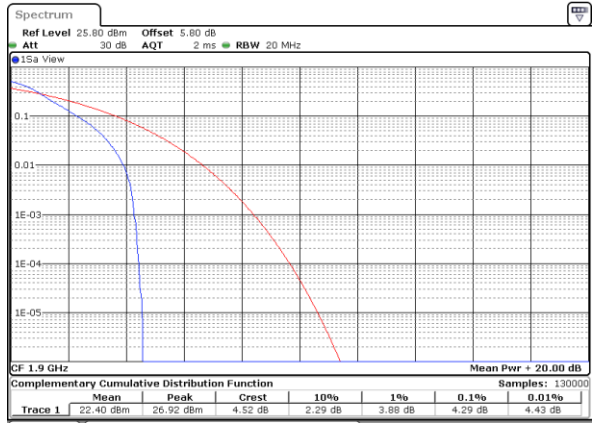

Date: 23 JUN 2020 00:30:00



N2 / 20MHz / 16QAM

Lowest Channel / 1RB0

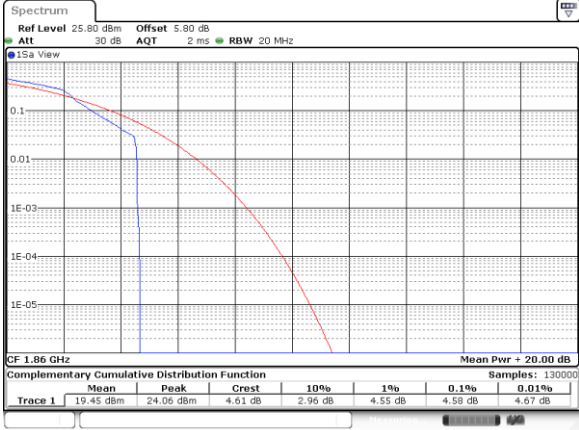

Date: 22 JUN 2020 23:56:51

Lowest Channel / 100RB0

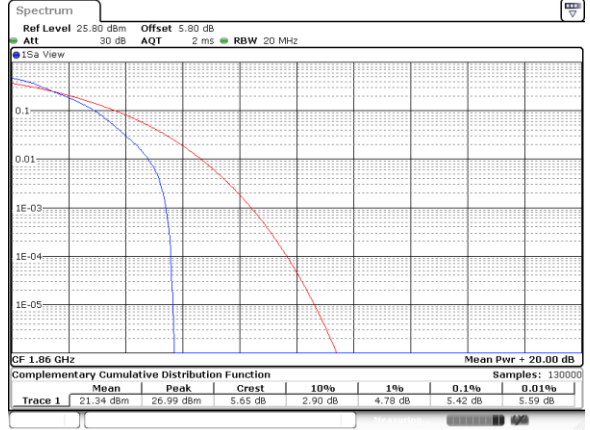

Date: 22 JUN 2020 23:50:53

Middle Channel / 1RB0

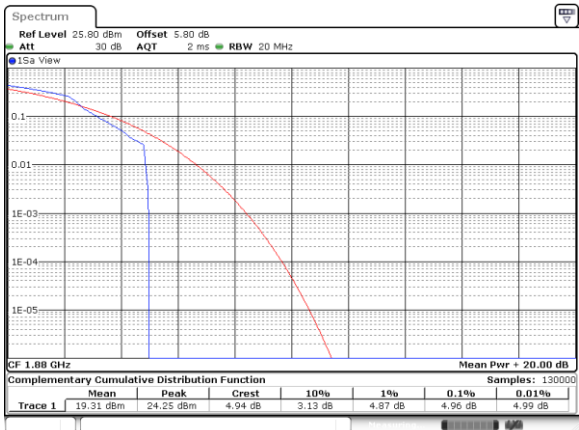

Date: 23 JUN 2020 00:13:05

Middle Channel / 100RB0

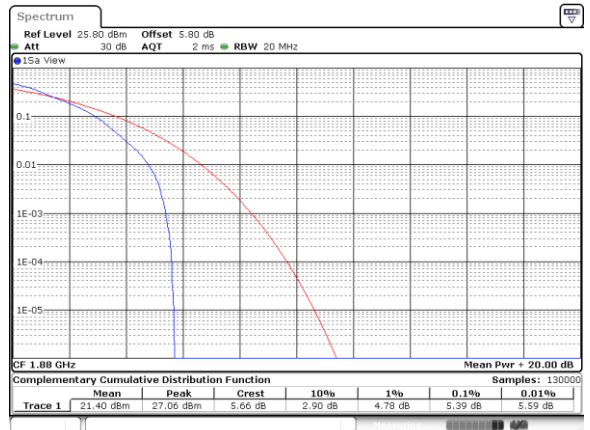

Date: 23 JUN 2020 00:25:31

Highest Channel / 1RB0

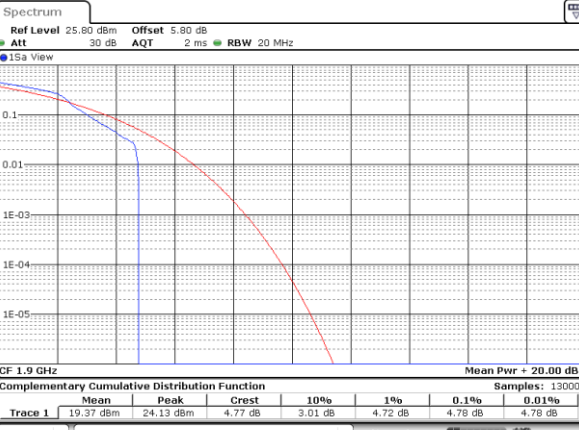

Date: 23 JUN 2020 00:35:46

Highest Channel / 100RB0



Date: 23 JUN 2020 00:30:41



N2 / 20MHz / 64QAM

Lowest Channel / 1RB0

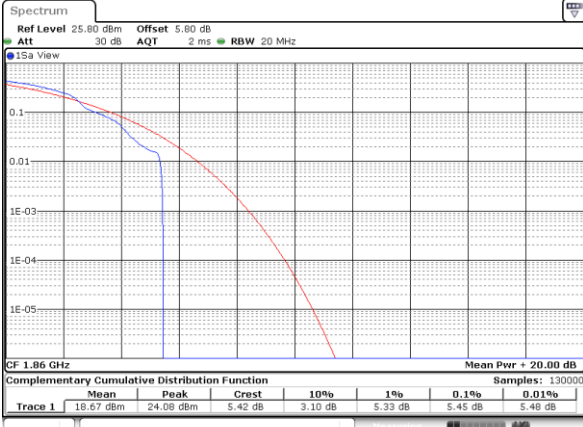

Date: 22 JUN 2020 23:58:14

Lowest Channel / 100RB0

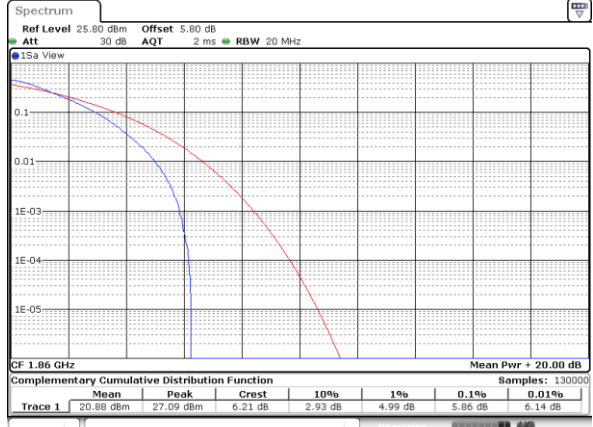

Date: 22 JUN 2020 23:51:35

Middle Channel / 1RB0

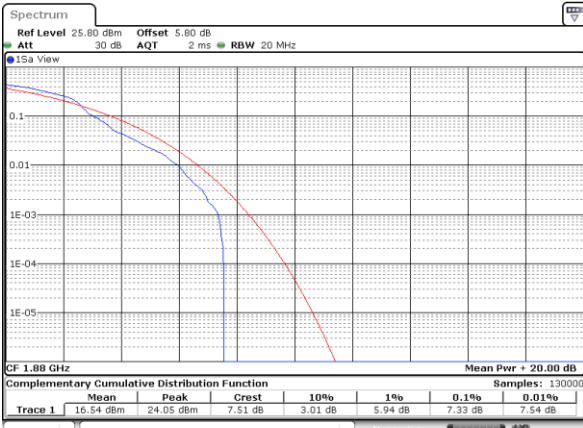

Date: 23 JUN 2020 00:14:12

Middle Channel / 100RB0

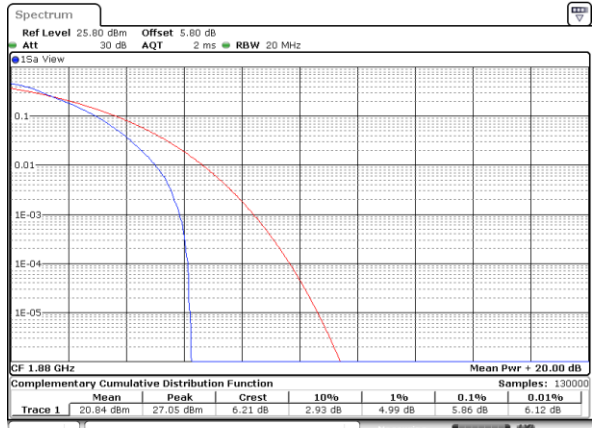

Date: 23 JUN 2020 00:26:25

Highest Channel / 1RB0

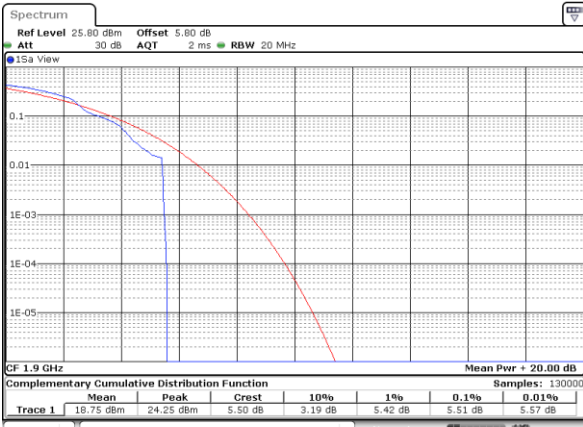

Date: 23 JUN 2020 00:36:54

Highest Channel / 100RB0

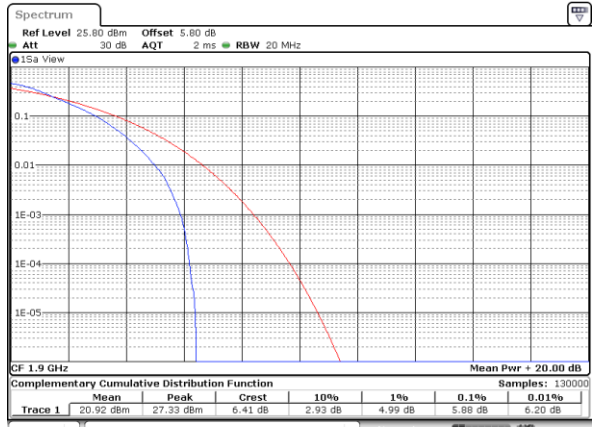

Date: 23 JUN 2020 00:31:23



N2 / 20MHz / 256QAM

Lowest Channel / 1RB0

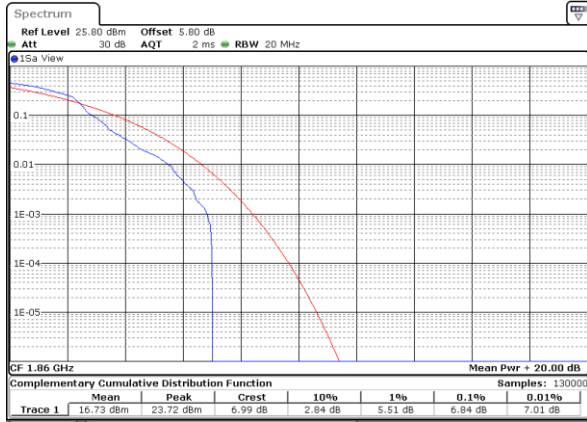

Date: 22 JUN 2020 23:53:53

Lowest Channel / 100RB0

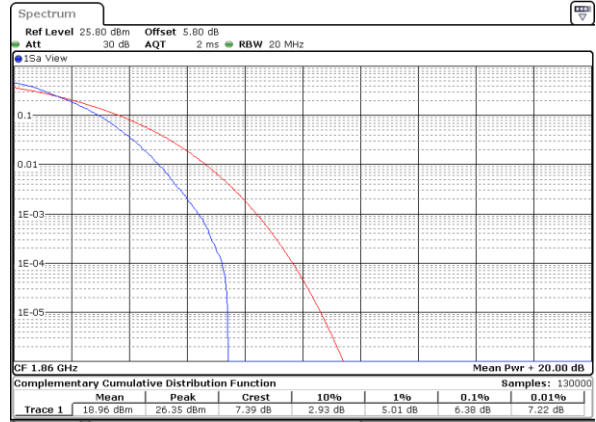

Date: 22 JUN 2020 23:48:03

Middle Channel / 1RB0

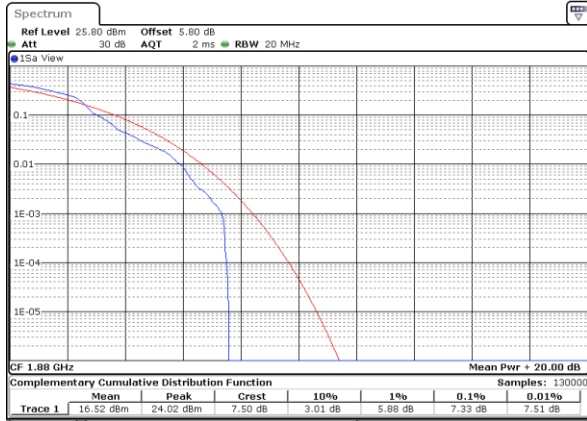

Date: 23 JUN 2020 00:10:18

Middle Channel / 100RB0

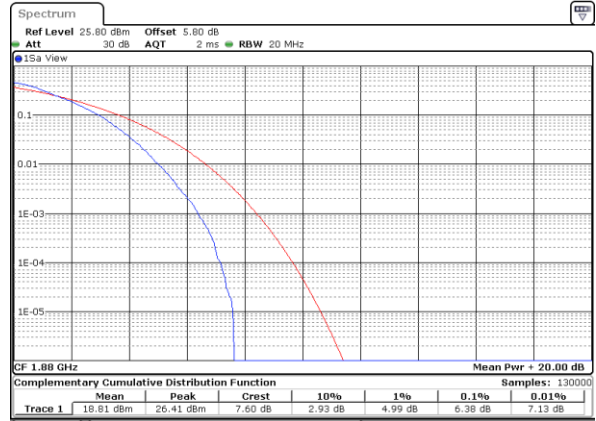

Date: 23 JUN 2020 00:23:07

Highest Channel / 1RB0

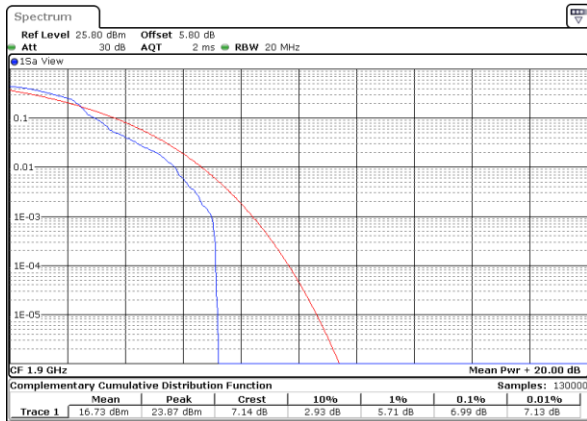

Date: 23 JUN 2020 00:33:26

Highest Channel / 100RB0

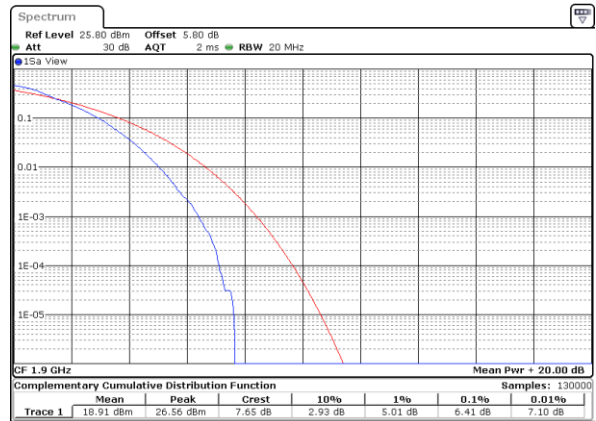

Date: 23 JUN 2020 00:28:32



26dB Bandwidth

Mode	N2 : 26dB BW(MHz)							
BW	5MHz		10MHz		15MHz		20MHz	
Mod.	QPSK	16QAM	QPSK	16QAM	QPSK	16QAM	QPSK	16QAM
Lowest CH	5.035	5.155	9.83	9.83	14.296	14.505	20.18	20.18
Middle CH	5.025	5.035	9.83	9.81	14.505	14.236	20.22	20.26
Highest CH	4.985	5.115	9.89	9.71	14.236	14.296	20.10	20.18
Mode	N2 : 26dB BW(MHz)							
BW	5MHz		10MHz		15MHz		20MHz	
Mod.	64QAM	256QAM	64QAM	256QAM	64QAM	256QAM	64QAM	256QAM
Lowest CH	5.145	5.225	9.93	9.69	14.146	14.386	20.10	20.02
Middle CH	5.075	5.175	10.09	9.85	14.505	14.356	20.06	20.10
Highest CH	5.035	5.115	9.83	9.77	14.176	14.116	20.14	20.18
Mode	N2 : 26dB BW(MHz)							
BW	5MHz		10MHz		15MHz		20MHz	
Mod.	BPSK		BPSK		BPSK		BPSK	
Lowest CH	5.005		9.79		14.416		20.14	
Middle CH	5.165		9.77		14.296		20.14	
Highest CH	5.175		10.05		14.296		20.14	



5MHz

Lowest Channel / BPSK

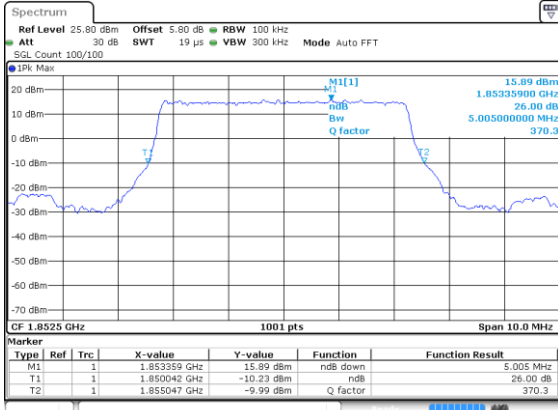

Lowest Channel / QPSK

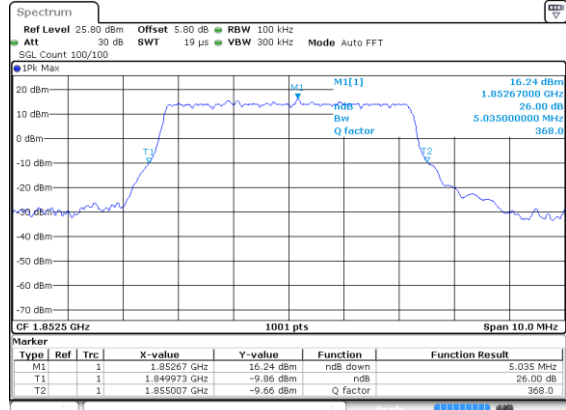

Middle Channel / BPSK

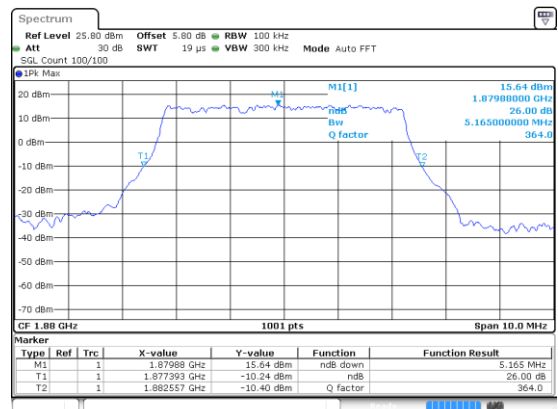

Middle Channel / QPSK

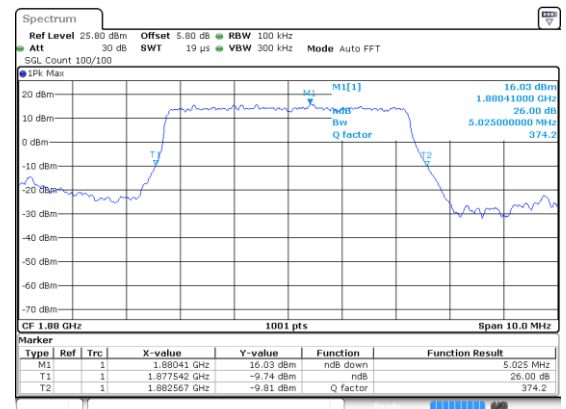

Highest Channel / BPSK

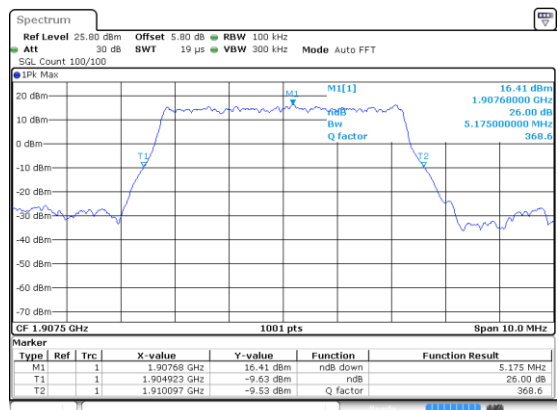

Highest Channel / QPSK

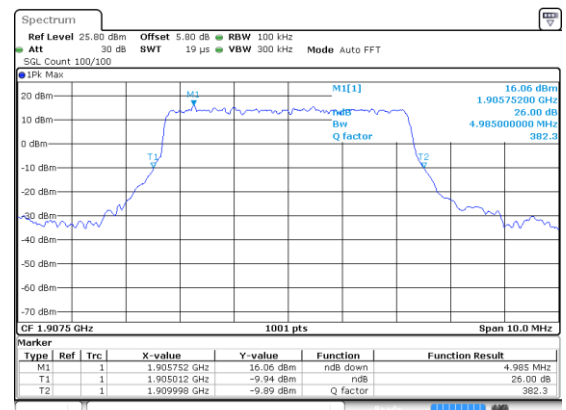



5MHz

Lowest Channel / 16QAM

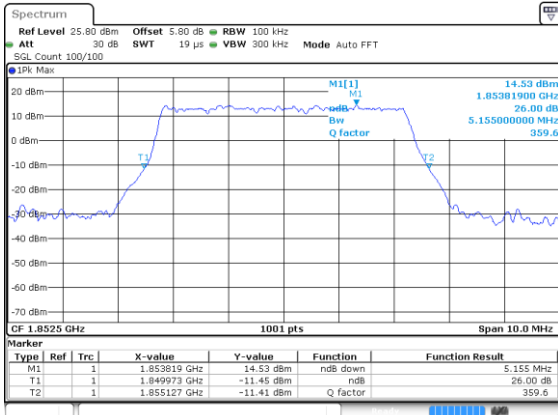

Lowest Channel / 64QAM

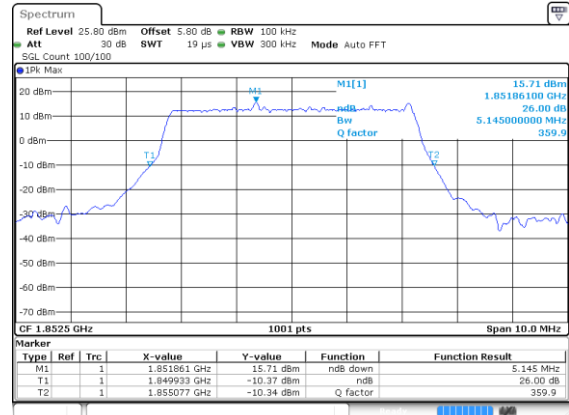

Middle Channel / 16QAM

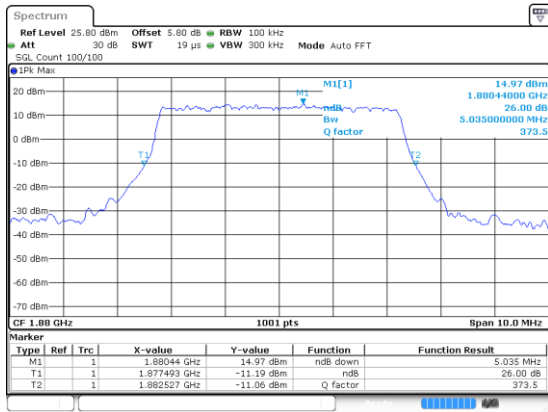

Middle Channel / 64QAM

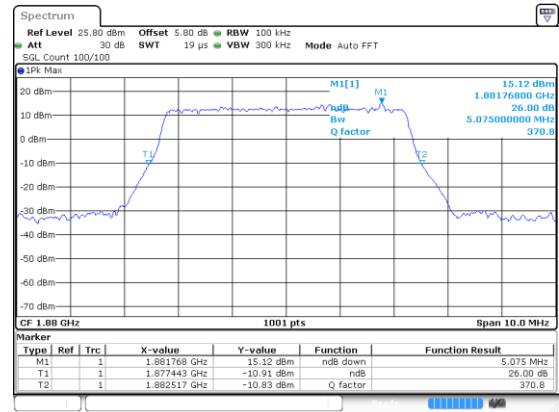

Highest Channel / 16QAM

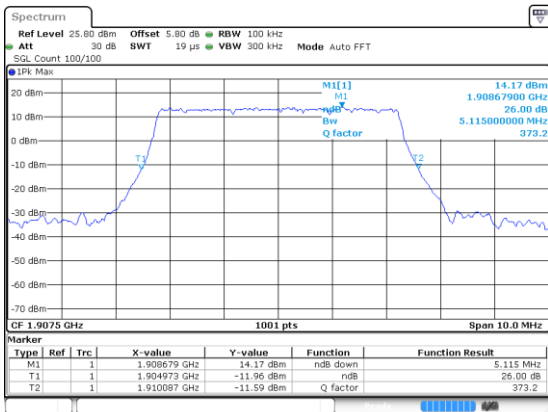

Highest Channel / 64QAM

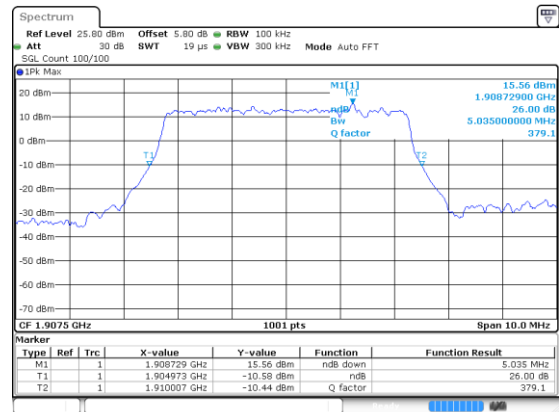



5MHz

Lowest Channel / 256QAM

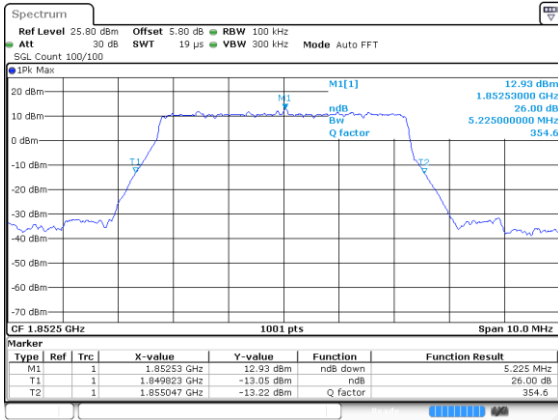

Middle Channel / 256QAM

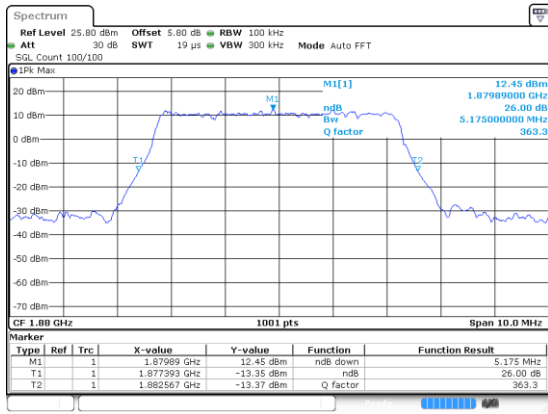

Highest Channel / 256QAM

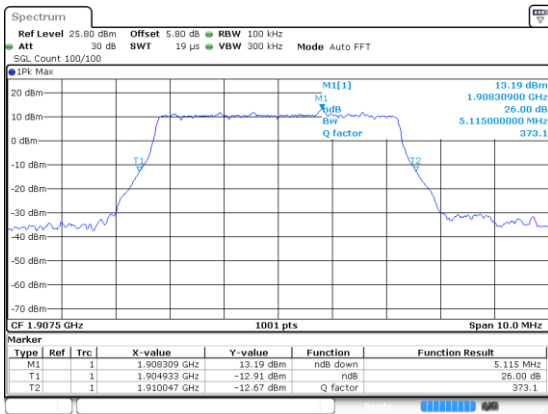



10MHz

Lowest Channel / BPSK

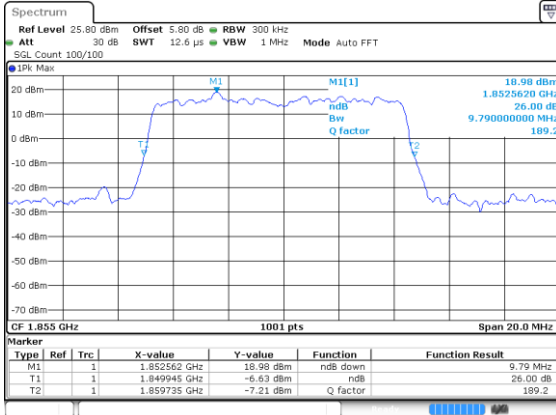

Lowest Channel / QPSK

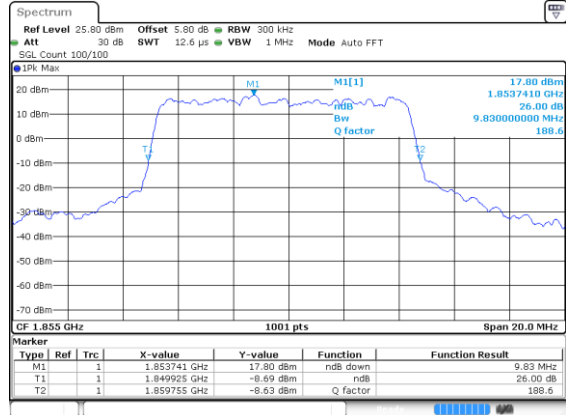

Middle Channel / BPSK

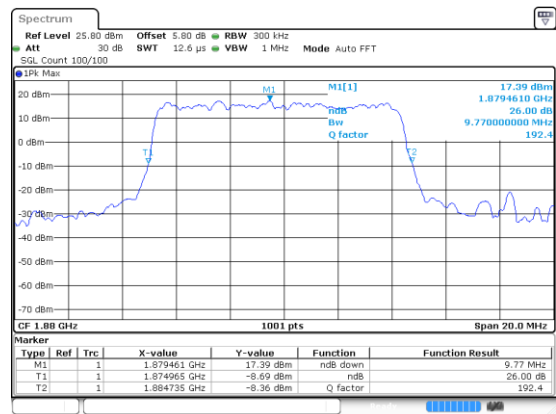

Middle Channel / QPSK

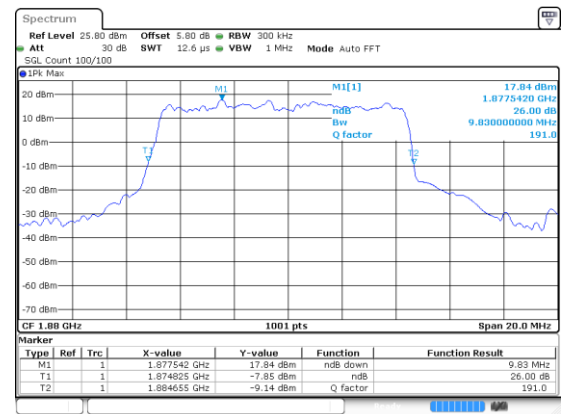

Highest Channel / BPSK

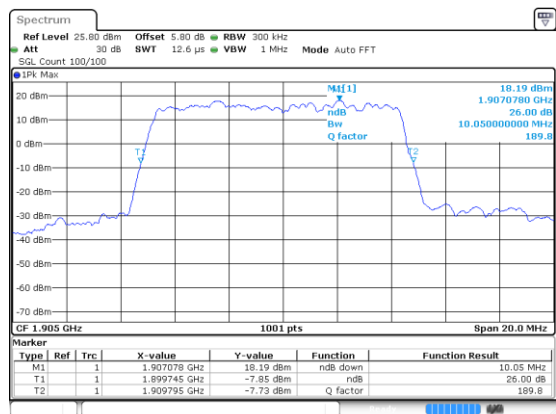

Highest Channel / QPSK

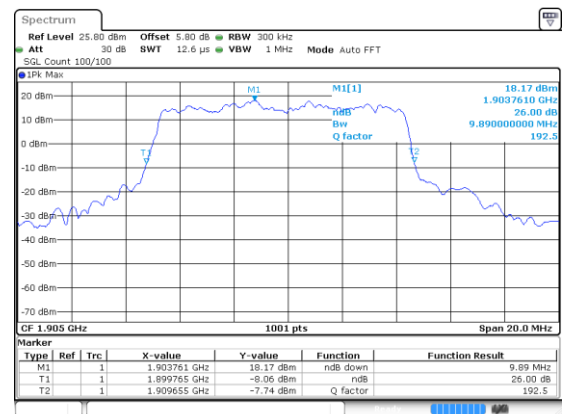



10MHz

Lowest Channel / 16QAM

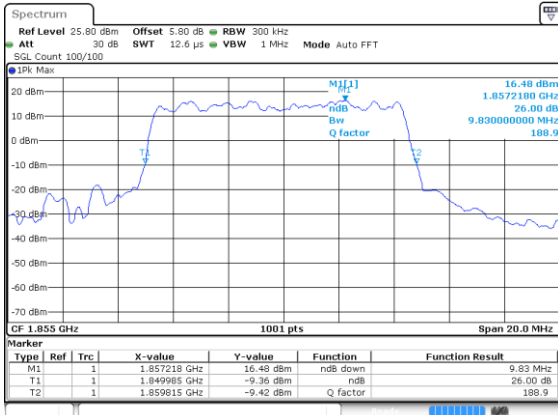

Lowest Channel / 64QAM

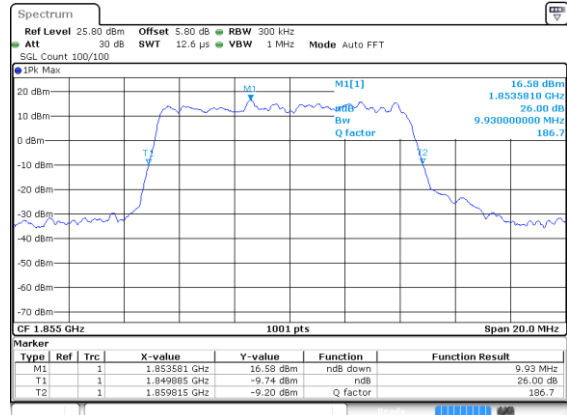

Middle Channel / 16QAM

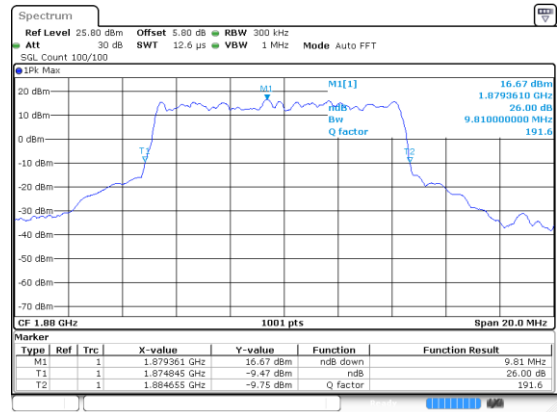

Middle Channel / 64QAM

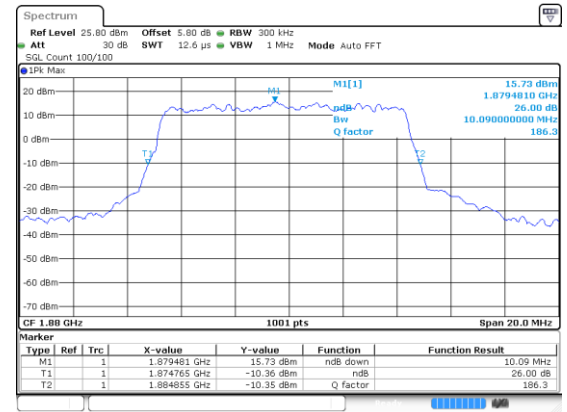

Highest Channel / 16QAM

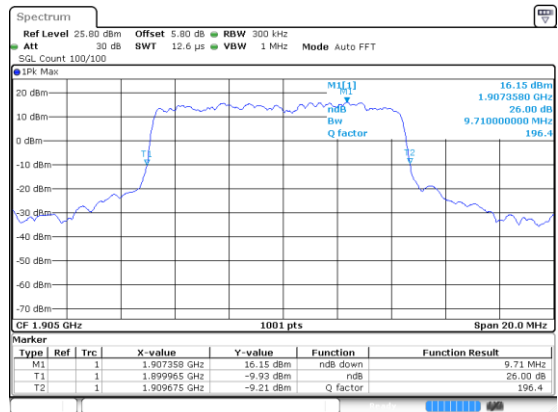

Highest Channel / 64QAM

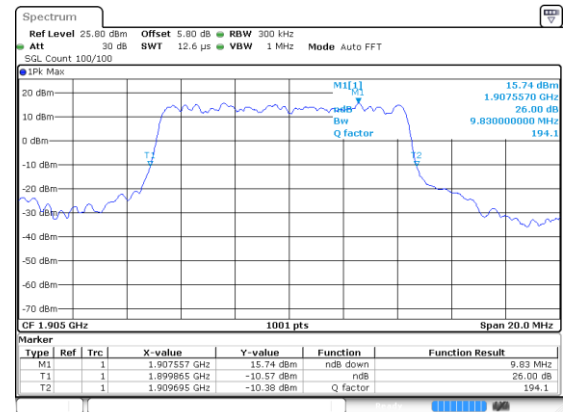



10MHz

Lowest Channel / 256QAM

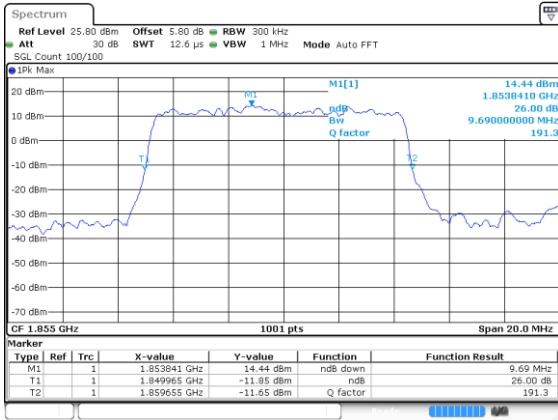

Middle Channel / 256QAM

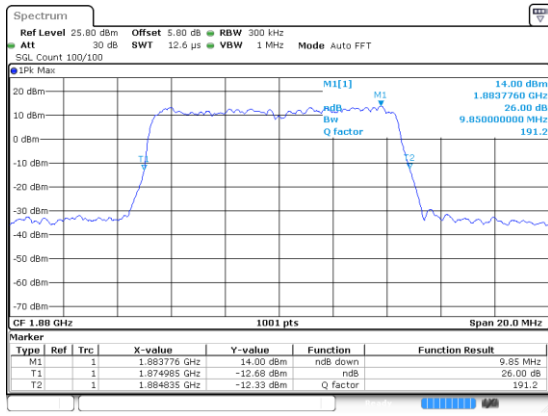

Highest Channel / 256QAM

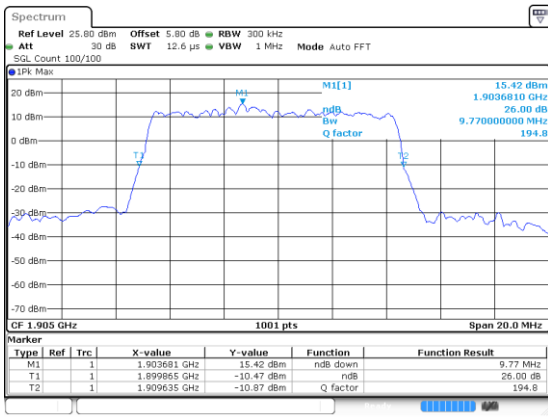



15MHz

Lowest Channel / BPSK

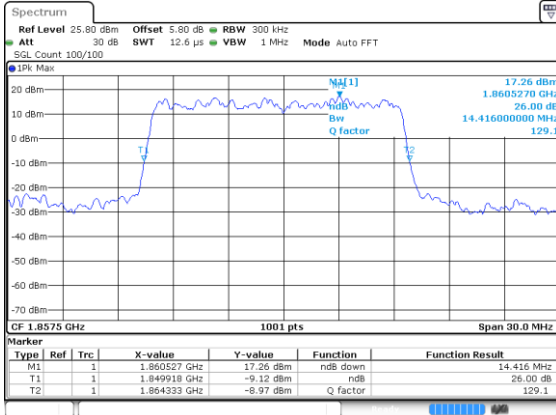

Lowest Channel / QPSK

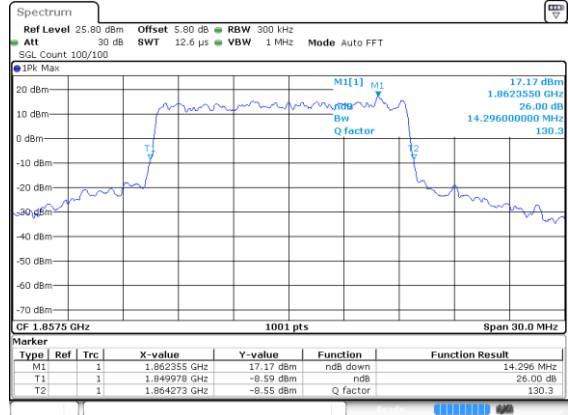

Middle Channel / BPSK

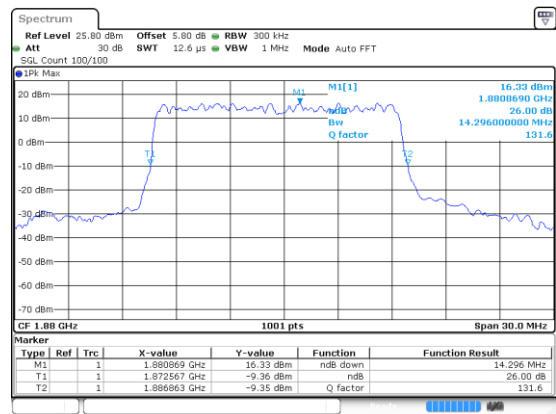

Middle Channel / QPSK

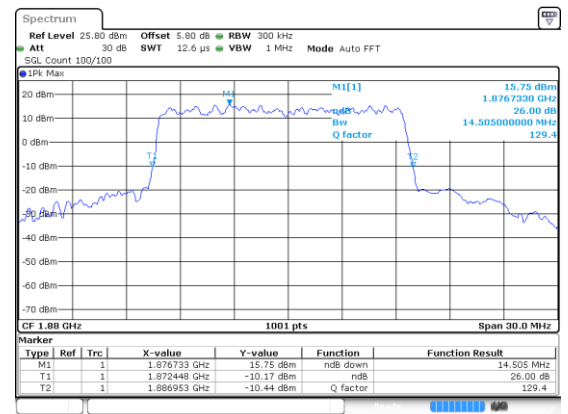

Highest Channel / BPSK

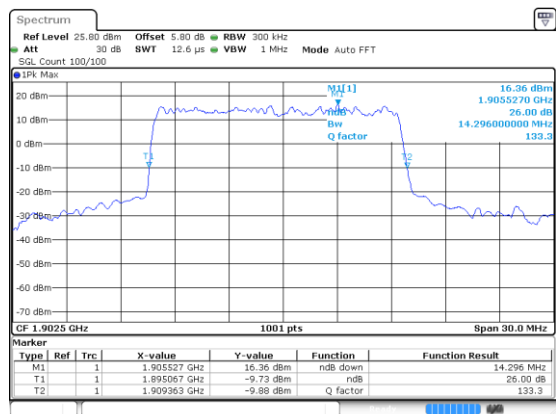

Highest Channel / QPSK

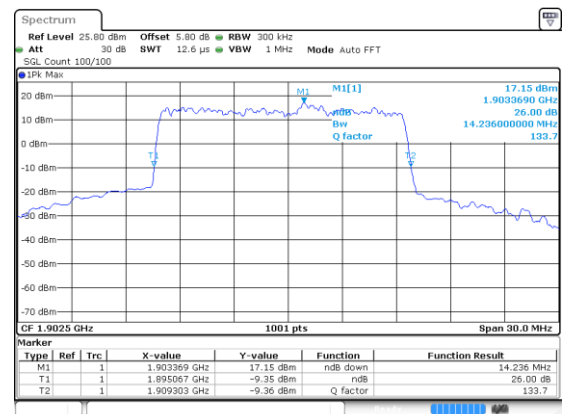



15MHz

Lowest Channel / 16QAM

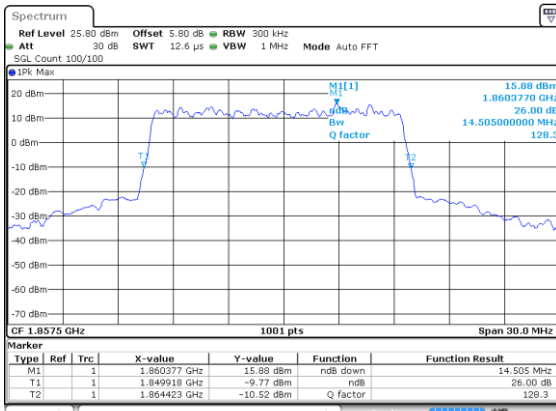

Lowest Channel / 64QAM

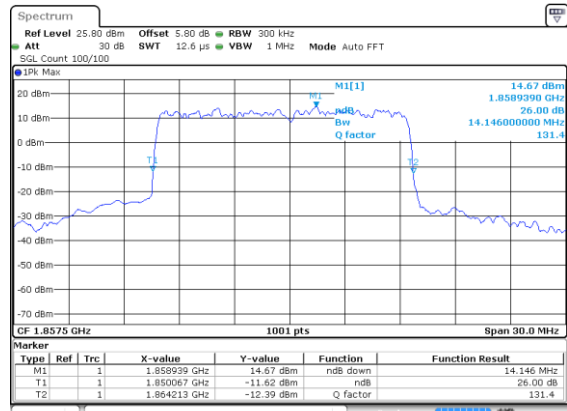

Middle Channel / 16QAM

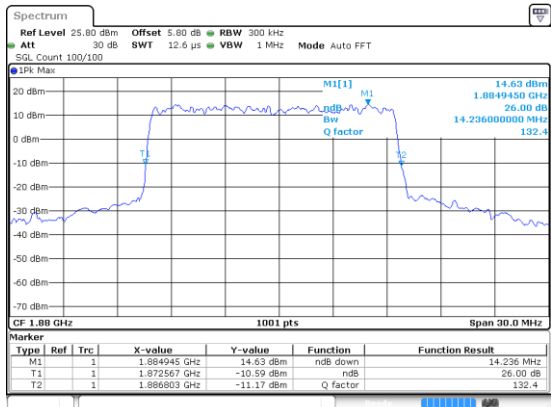

Middle Channel / 64QAM

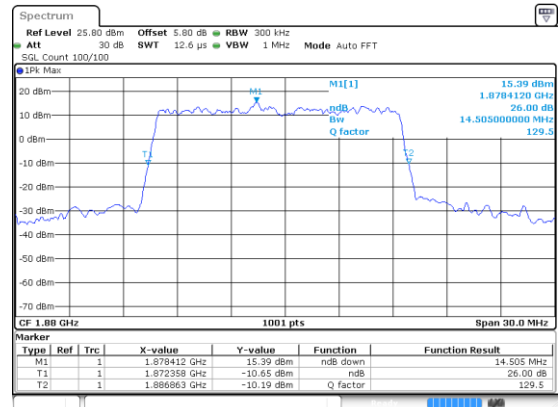

Highest Channel / 16QAM

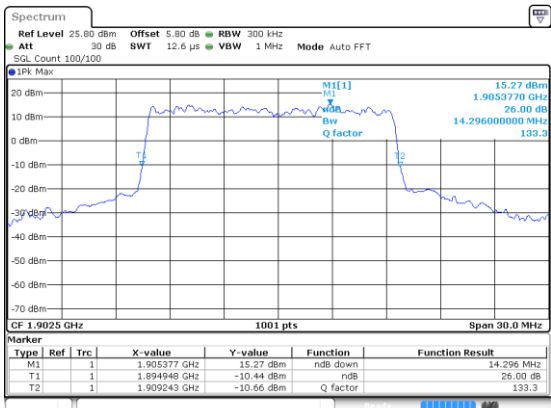

Highest Channel / 64QAM

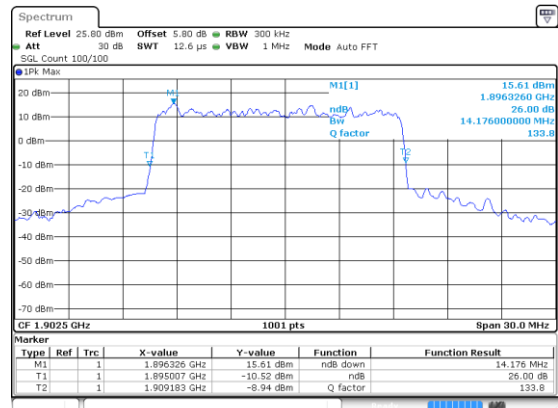



15MHz

Lowest Channel / 256QAM

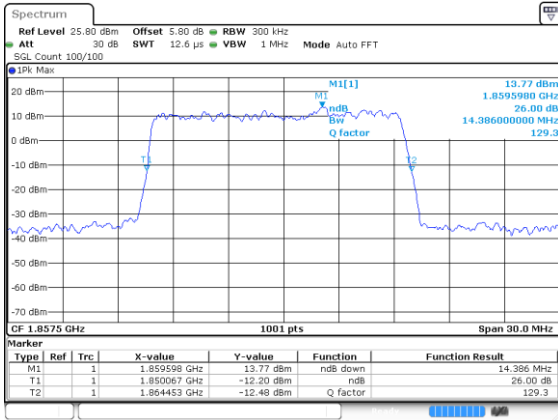

Middle Channel / 256QAM

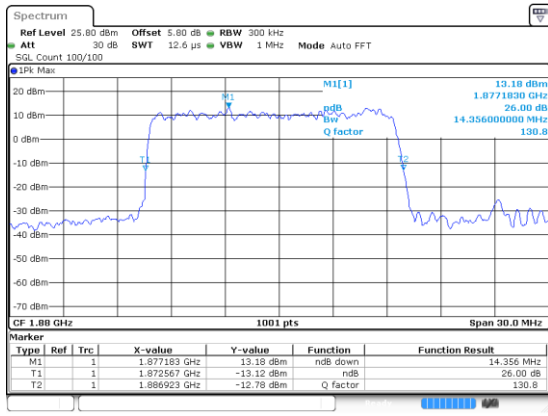

Highest Channel / 256QAM

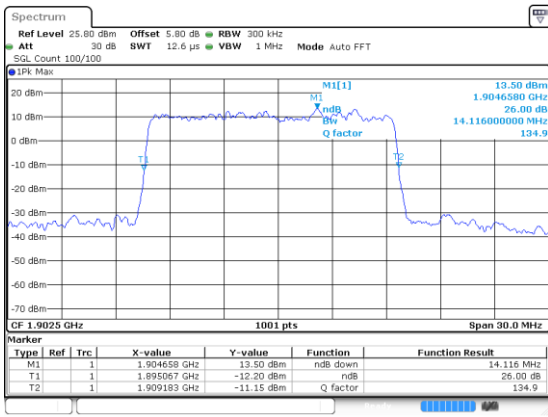



20MHz

Lowest Channel / BPSK

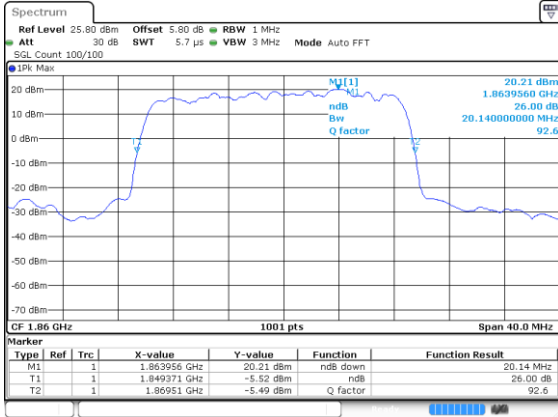

Lowest Channel / QPSK

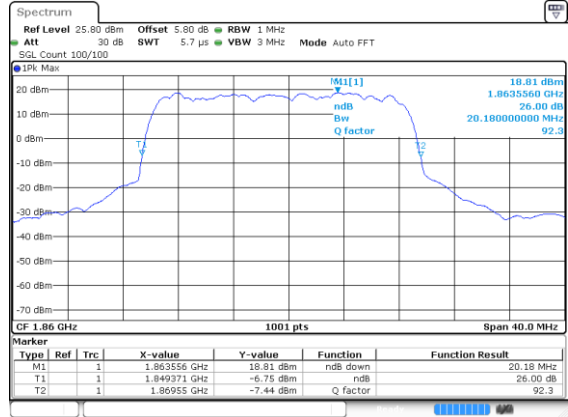

Middle Channel / BPSK

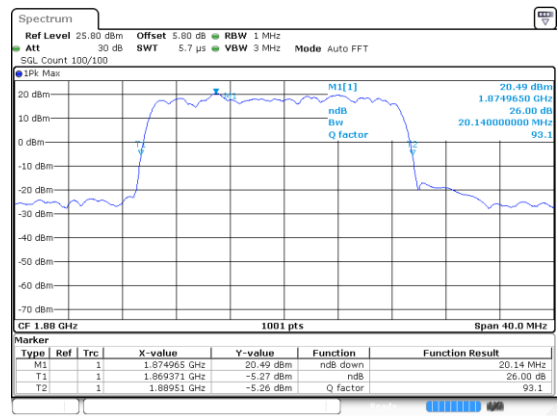

Middle Channel / QPSK

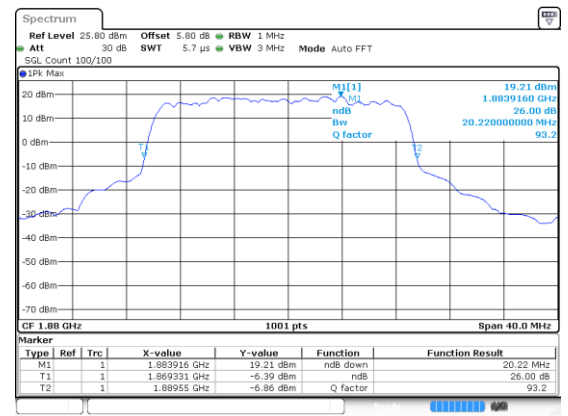

Highest Channel / BPSK

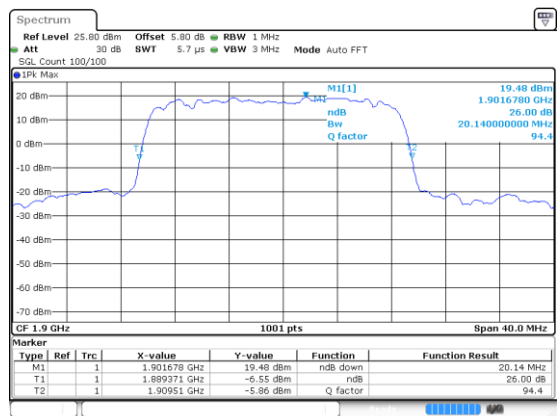

Highest Channel / QPSK

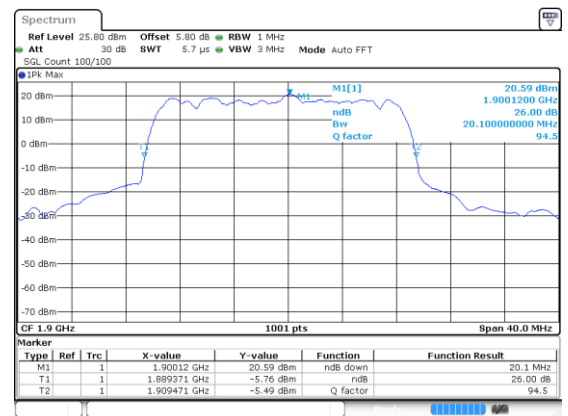



20MHz

Lowest Channel / 16QAM

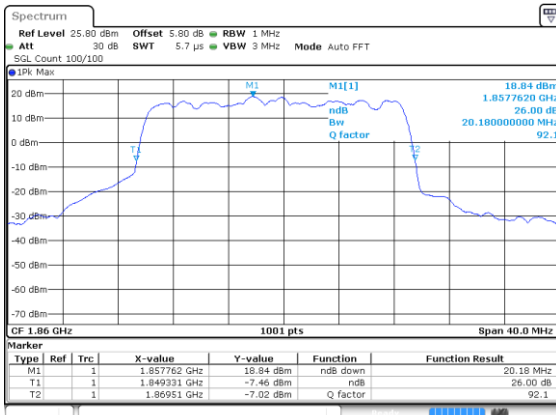

Lowest Channel / 64QAM

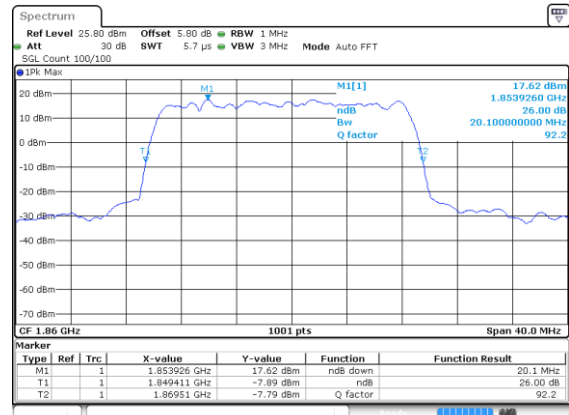

Middle Channel / 16QAM

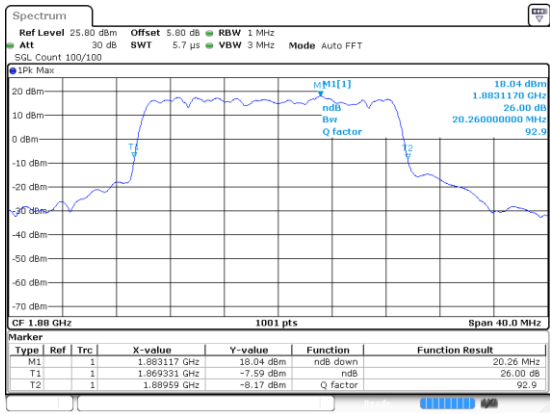

Middle Channel / 64QAM

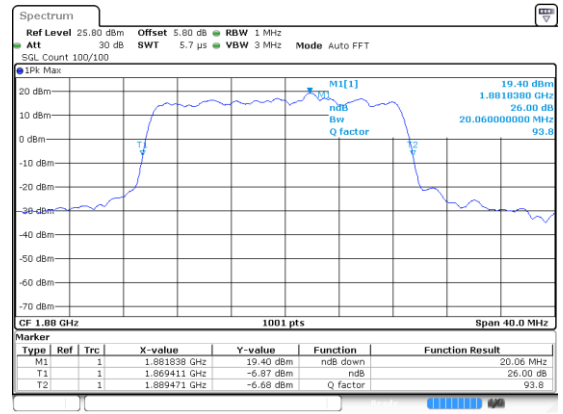

Highest Channel / 16QAM

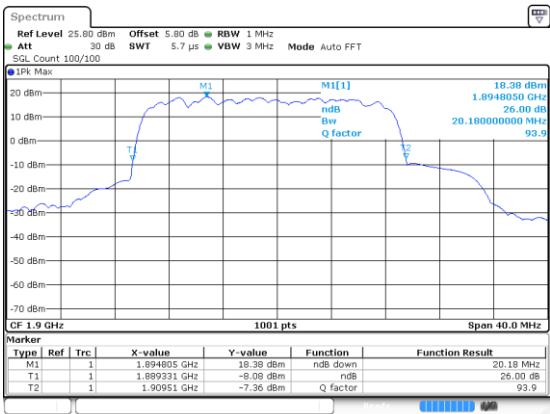

Highest Channel / 64QAM

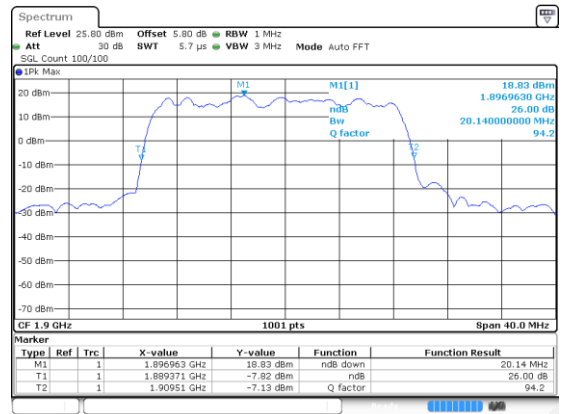



20MHz

Lowest Channel / 256QAM

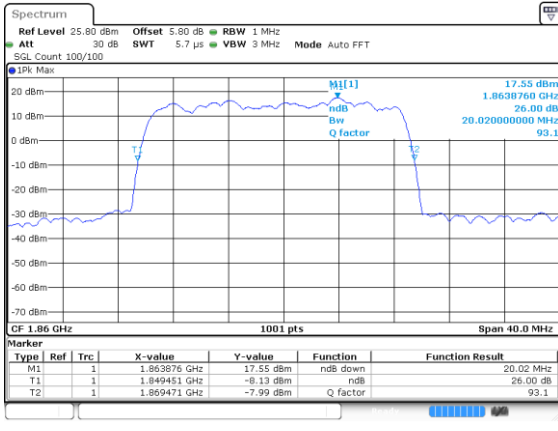

Middle Channel / 256QAM

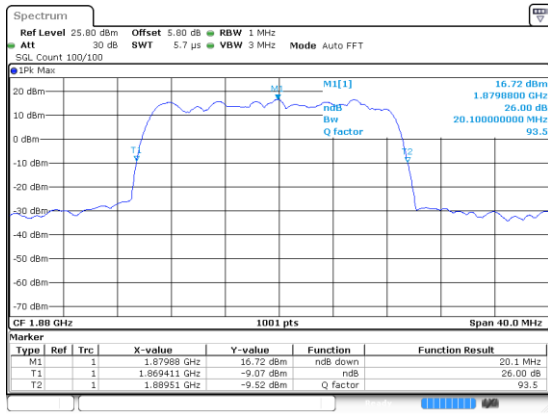

Highest Channel / 256QAM

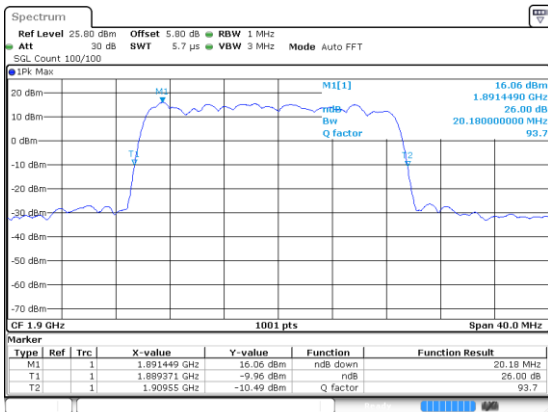



Occupied Bandwidth

Mode	N2 : OB BW(MHz)							
BW	5MHz		10MHz		15MHz		20MHz	
Mod.	QPSK	16QAM	QPSK	16QAM	QPSK	16QAM	QPSK	16QAM
Lowest CH	4.52	4.49	9.05	9.03	13.46	13.49	18.38	18.46
Middle CH	4.49	4.49	9.03	9.09	13.46	13.46	18.34	18.42
Highest CH	4.48	4.48	9.03	9.05	13.46	13.46	18.26	18.42
Mode	N2 : OB BW(MHz)							
BW	5MHz		10MHz		15MHz		20MHz	
Mod.	64QAM	256QAM	64QAM	256QAM	64QAM	256QAM	64QAM	256QAM
Lowest CH	4.49	4.49	9.01	9.05	13.49	13.46	18.38	18.34
Middle CH	4.47	4.50	9.05	8.99	13.46	13.46	18.26	18.34
Highest CH	4.50	4.46	9.07	9.03	13.43	13.49	18.30	18.26
Mode	N2 : OB BW(MHz)							
BW	5MHz		10MHz		15MHz		20MHz	
Mod.	BPSK		BPSK		BPSK		BPSK	
Lowest CH	4.47		9.01		13.43		18.30	
Middle CH	4.47		9.05		13.46		18.34	
Highest CH	4.48		9.07		13.46		18.22	



5MHz

Lowest Channel / BPSK

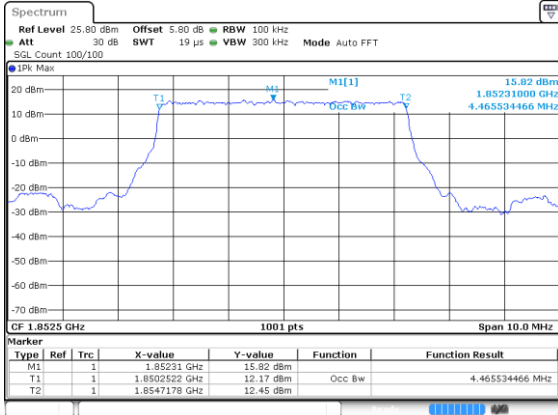

Lowest Channel / QPSK

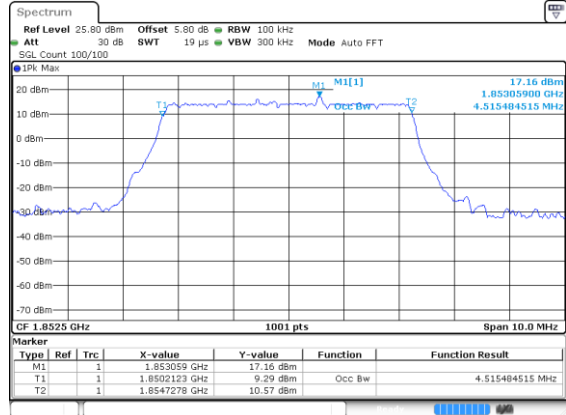

Middle Channel / BPSK

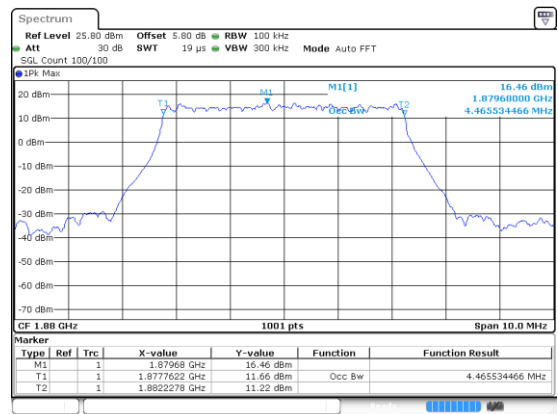

Middle Channel / QPSK

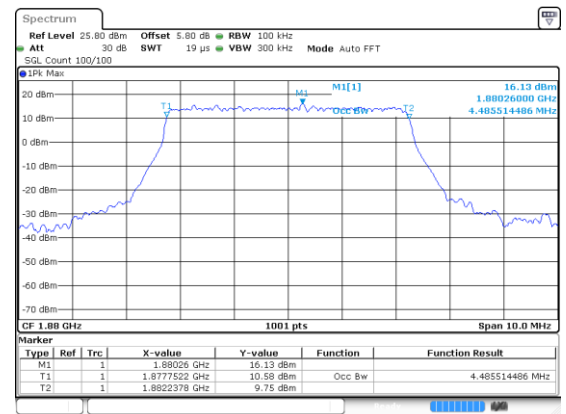

Highest Channel / BPSK

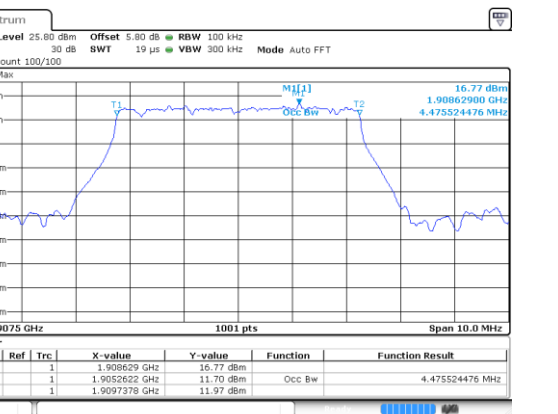

Highest Channel / QPSK

