

33_WLAN5GHz_802.11a 6Mbps_Back_5mm_Ch40

Communication System: UID 0, 802.11a (0); Frequency: 5200 MHz;Duty Cycle: 1:1.014
Medium: HSL_5000 Medium parameters used: $f = 5200$ MHz; $\sigma = 4.626$ S/m; $\epsilon_r = 37.086$; $\rho = 1000$ kg/m³

Ambient Temperature : 23.4 °C; Liquid Temperature : 22.8 °C

DASY5 Configuration:

- Probe: EX3DV4 - SN3935; ConvF(5.04, 5.04, 5.04); Calibrated: 2020.5.27
- Sensor-Surface: 1.4mm (Mechanical Surface Detection)
- Electronics: DAE4 Sn1358; Calibrated: 2020.4.28
- Phantom: SAM1; Type: SAM; Serial: TP-1697
- Measurement SW: DASY52, Version 52.10 (4); SEMCAD X Version 14.6.14 (7483)

Area Scan (101x101x1): Interpolated grid: dx=1.000 mm, dy=1.000 mm
Maximum value of SAR (interpolated) = 2.64 W/kg

Zoom Scan (9x9x7)/Cube 0: Measurement grid: dx=4mm, dy=4mm, dz=1.4mm
Reference Value = 1.846 V/m; Power Drift = 0.09 dB
Peak SAR (extrapolated) = 3.89 W/kg
SAR(1 g) = 1 W/kg; SAR(10 g) = 0.237 W/kg
Maximum value of SAR (measured) = 2.50 W/kg

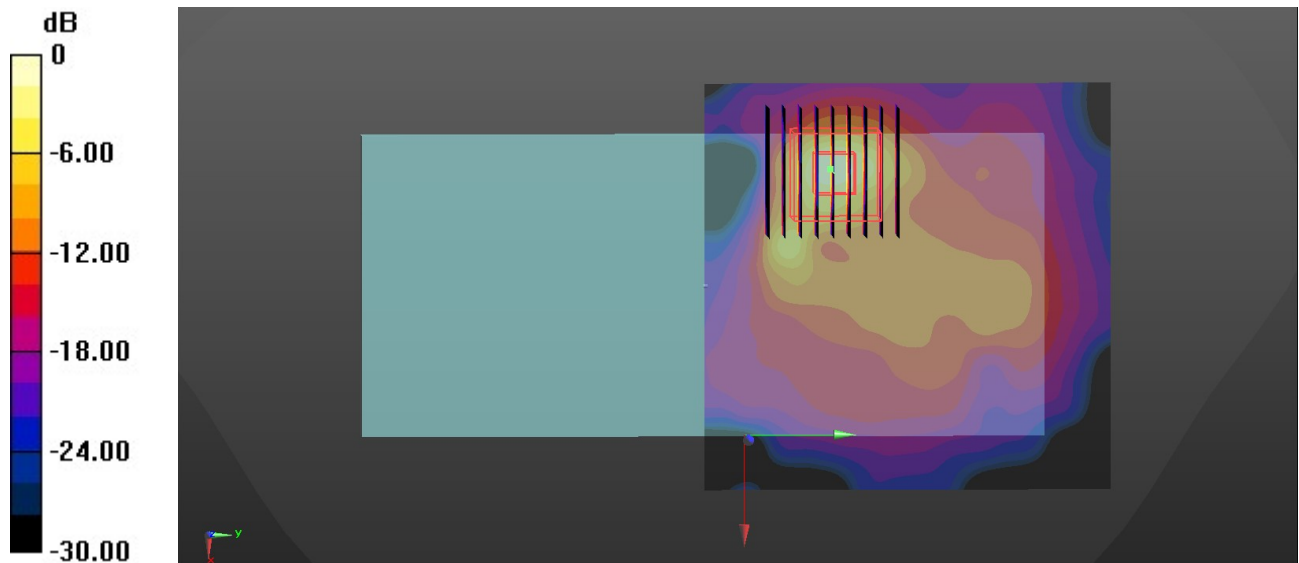

0 dB = 2.50 W/kg = 3.98 dBW/kg

34_WLAN5GHz_802.11a_6Mbps_Back_5mm_Ch165

Communication System: UID 0, 802.11a (0); Frequency: 5825 MHz;Duty Cycle: 1:1.014
Medium: HSL_5000 Medium parameters used: $f = 5825$ MHz; $\sigma = 5.282$ S/m; $\epsilon_r = 36.176$; $\rho = 1000$ kg/m³

Ambient Temperature : 23.2 °C; Liquid Temperature : 22.8 °C

DASY5 Configuration:

- Probe: EX3DV4 - SN3935; ConvF(4.67, 4.67, 4.67); Calibrated: 2020.5.27
- Sensor-Surface: 1.4mm (Mechanical Surface Detection)
- Electronics: DAE4 Sn1358; Calibrated: 2020.4.28
- Phantom: SAM1; Type: SAM; Serial: TP-1697
- Measurement SW: DASY52, Version 52.10 (4); SEMCAD X Version 14.6.14 (7483)

Area Scan (101x101x1): Interpolated grid: dx=1.000 mm, dy=1.000 mm
Maximum value of SAR (interpolated) = 1.90 W/kg

Zoom Scan (9x9x7)/Cube 0: Measurement grid: dx=4mm, dy=4mm, dz=1.4mm
Reference Value = 3.488 V/m; Power Drift = -0.08 dB
Peak SAR (extrapolated) = 4.41 W/kg
SAR(1 g) = 0.877 W/kg; SAR(10 g) = 0.224 W/kg
Maximum value of SAR (measured) = 2.46 W/kg

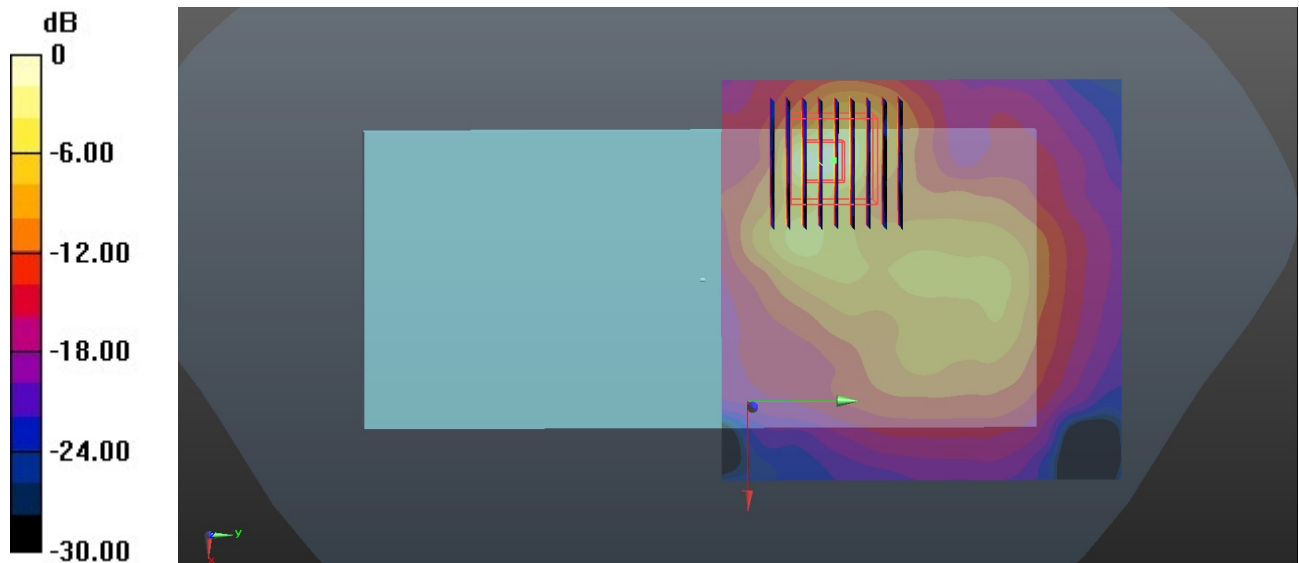

0 dB = 2.46 W/kg = 3.91 dBW/kg

35_Bluetooth_1Mbps_Back_5mm_Ch39

Communication System: UID 0, Bluetooth (0); Frequency: 2441 MHz; Duty Cycle: 1:1.303
 Medium: HSL_2450 Medium parameters used: $f = 2441$ MHz; $\sigma = 1.839$ S/m; $\epsilon_r = 39.037$; $\rho = 1000$ kg/m³
 Ambient Temperature : 23.4 °C; Liquid Temperature : 22.6 °C

DASY5 Configuration:

- Probe: EX3DV4 - SN3935; ConvF(7.6, 7.6, 7.6); Calibrated: 2020.5.27
- Sensor-Surface: 1.4mm (Mechanical Surface Detection)
- Electronics: DAE4 Sn1358; Calibrated: 2020.4.28
- Phantom: SAM1; Type: SAM; Serial: TP-1697
- Measurement SW: DASY52, Version 52.10 (4); SEMCAD X Version 14.6.14 (7483)

Area Scan (91x81x1): Interpolated grid: dx=1.200 mm, dy=1.200 mm
 Maximum value of SAR (interpolated) = 0.278 W/kg

Zoom Scan (7x8x7)/Cube 0: Measurement grid: dx=5mm, dy=5mm, dz=5mm
 Reference Value = 2.611 V/m; Power Drift = 0.03 dB
 Peak SAR (extrapolated) = 0.408 W/kg
SAR(1 g) = 0.141 W/kg; SAR(10 g) = 0.055 W/kg
 Maximum value of SAR (measured) = 0.292 W/kg

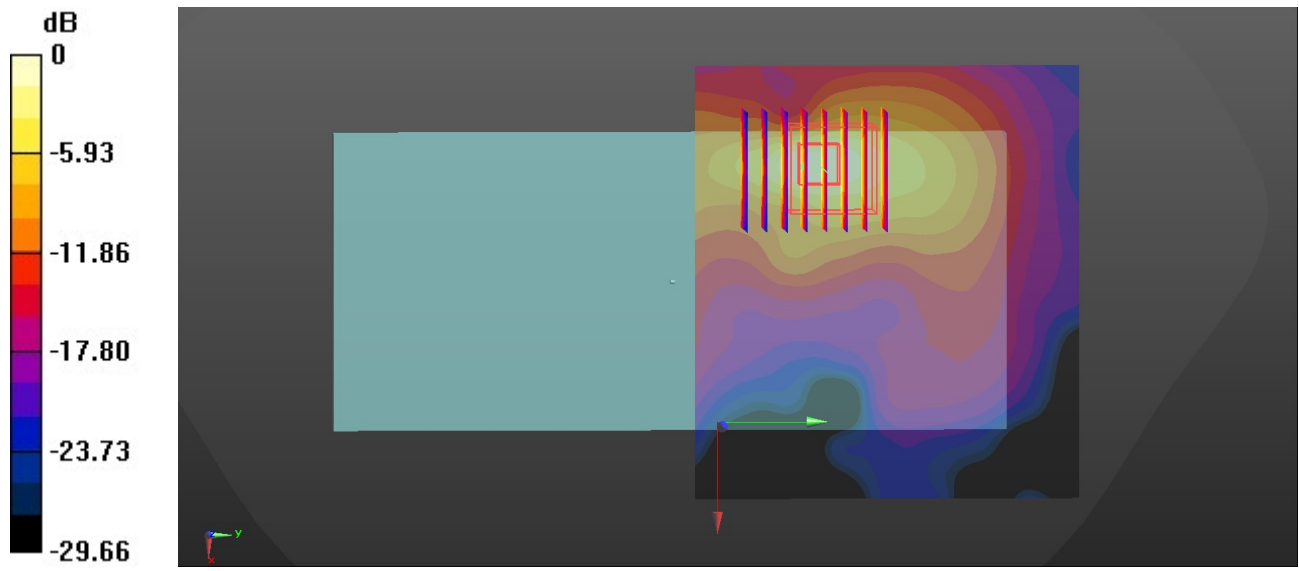

0 dB = 0.292 W/kg = -5.35 dBW/kg

36_GSM850_GPRS 4 Tx slots_Back_5mm_Ch189

Communication System: UID 0, GSM850 (0); Frequency: 836.4 MHz; Duty Cycle: 1:2.08
Medium: HSL_850 Medium parameters used: $f = 836.4$ MHz; $\sigma = 0.925$ S/m; $\epsilon_r = 41.43$; $\rho = 1000$ kg/m³

Ambient Temperature : 23.2 °C; Liquid Temperature : 22.9 °C

DASY5 Configuration:

- Probe: EX3DV4 - SN3935; ConvF(10.31, 10.31, 10.31); Calibrated: 2020.5.27
- Sensor-Surface: 1.4mm (Mechanical Surface Detection)
- Electronics: DAE4 Sn1358; Calibrated: 2020.4.28
- Phantom: SAM1; Type: SAM; Serial: TP-1697
- Measurement SW: DASY52, Version 52.10 (4); SEMCAD X Version 14.6.14 (7483)

Area Scan (71x71x1): Interpolated grid: dx=1.500 mm, dy=1.500 mm

Maximum value of SAR (interpolated) = 1.251 W/kg

Zoom Scan (5x5x7)/Cube 0: Measurement grid: dx=8mm, dy=8mm, dz=5mm

Reference Value = 14.09 V/m; Power Drift = -0.09 dB

Peak SAR (extrapolated) = 1.662 W/kg

SAR(1 g) = 0.721 W/kg; SAR(10 g) = 0.393 W/kg

Maximum value of SAR (measured) = 1.289 W/kg

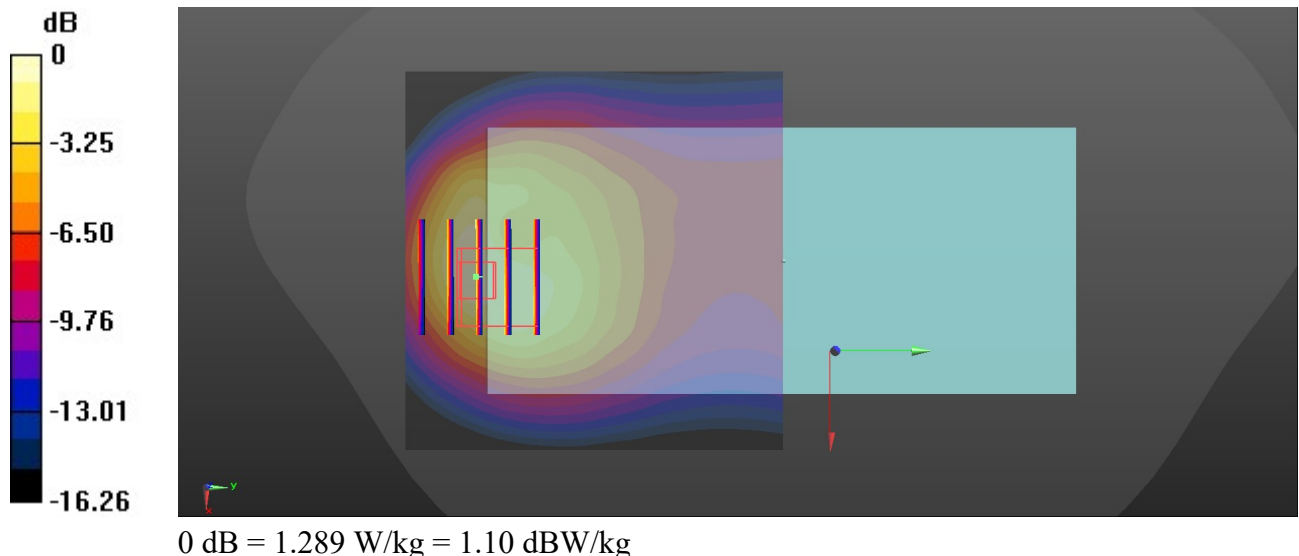

37_GSM1900_GPRS 4 Tx slots_Back_5mm_Ch810

Communication System: UID 0, PCS (0); Frequency: 1909.8 MHz; Duty Cycle: 1:2.08
Medium: HSL_1900 Medium parameters used: $f = 1910$ MHz; $\sigma = 1.468$ S/m; $\epsilon_r = 40.08$; $\rho = 1000$ kg/m³
Ambient Temperature : 23.2 °C; Liquid Temperature : 22.7 °C

DASY5 Configuration:

- Probe: EX3DV4 - SN3935; ConvF(8.35, 8.35, 8.35); Calibrated: 2020.5.27
- Sensor-Surface: 1.4mm (Mechanical Surface Detection)
- Electronics: DAE4 Sn1358; Calibrated: 2020.4.28
- Phantom: SAM1; Type: SAM; Serial: TP-1697
- Measurement SW: DASY52, Version 52.10 (4); SEMCAD X Version 14.6.14 (7483)

Area Scan (71x71x1): Interpolated grid: $dx=1.500$ mm, $dy=1.500$ mm
Maximum value of SAR (interpolated) = 0.892 W/kg

Zoom Scan (5x5x7)/Cube 0: Measurement grid: $dx=8$ mm, $dy=8$ mm, $dz=5$ mm
Reference Value = 3.208 V/m; Power Drift = 0.09 dB
Peak SAR (extrapolated) = 1.258 W/kg
SAR(1 g) = 0.636 W/kg; SAR(10 g) = 0.301 W/kg
Maximum value of SAR (measured) = 0.986 W/kg

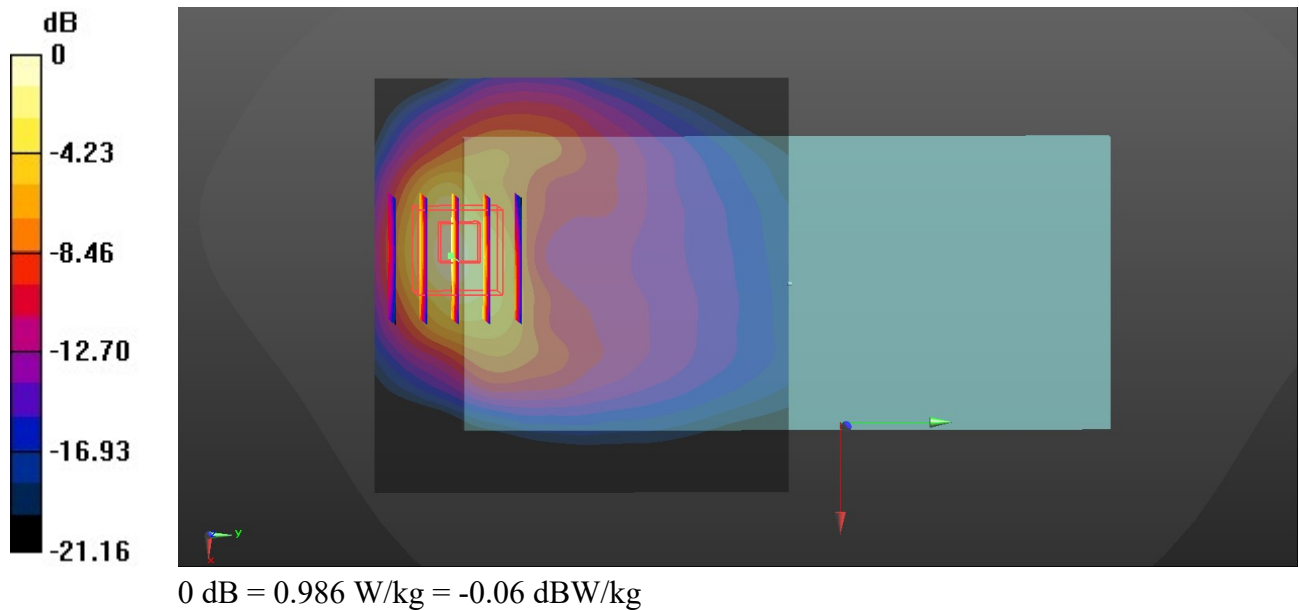

38_WCDMA II_RMC 12.2Kbps_Back_5mm_Ch9400

Communication System: UID 0, WCDMA (0); Frequency: 1880 MHz; Duty Cycle: 1:1
Medium: HSL1900 Medium parameters used: $f = 1880$ MHz; $\sigma = 1.451$ S/m; $\epsilon_r = 40.099$; $\rho = 1000$ kg/m³
Ambient Temperature : 23.2 °C; Liquid Temperature : 22.7 °C

DASY5 Configuration:

- Probe: EX3DV4 - SN3935; ConvF(8.35, 8.35, 8.35); Calibrated: 2020.5.27
- Sensor-Surface: 1.4mm (Mechanical Surface Detection)
- Electronics: DAE4 Sn1358; Calibrated: 2020.4.28
- Phantom: SAM1; Type: SAM; Serial: TP-1697
- Measurement SW: DASY52, Version 52.10 (4); SEMCAD X Version 14.6.14 (7483)

Area Scan (71x71x1): Interpolated grid: $dx=1.500$ mm, $dy=1.500$ mm
Maximum value of SAR (interpolated) = 0.705 W/kg

Zoom Scan (5x5x7)/Cube 0: Measurement grid: $dx=8$ mm, $dy=8$ mm, $dz=5$ mm
Reference Value = 1.900 V/m; Power Drift = 0.02 dB
Peak SAR (extrapolated) = 0.950 W/kg
SAR(1 g) = 0.460 W/kg; SAR(10 g) = 0.219 W/kg
Maximum value of SAR (measured) = 0.757 W/kg

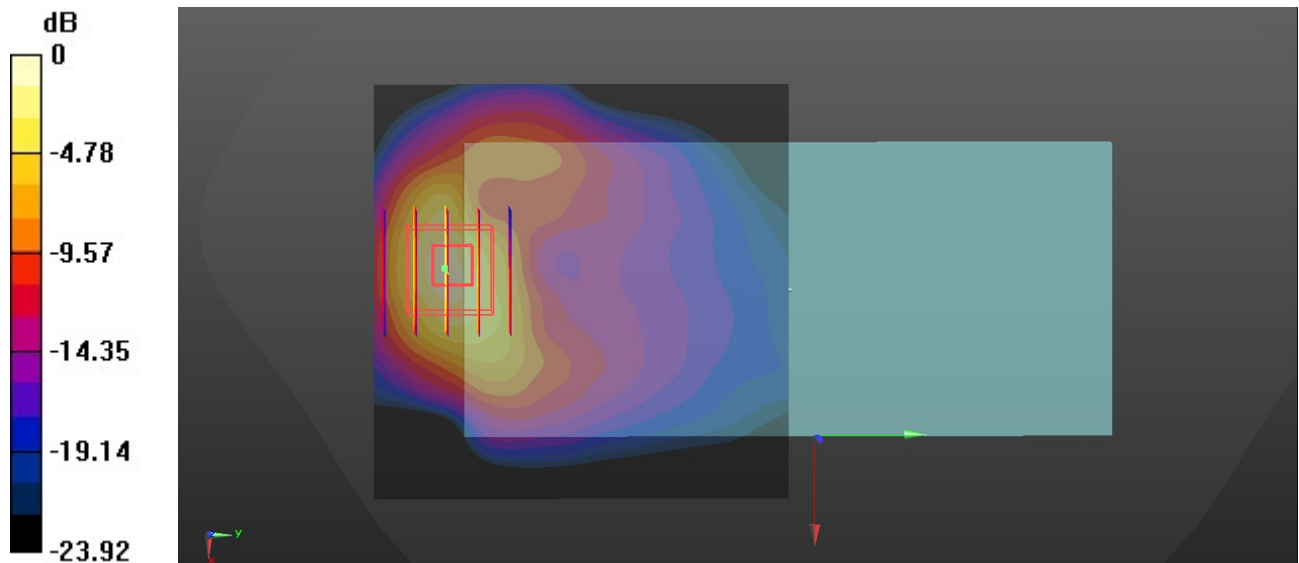

0 dB = 0.757 W/kg = -1.21 dBW/kg

39_WCDMA V_RMC 12.2Kbps_Back_5mm_Ch4182

Communication System: UID 0, WCDMA (0); Frequency: 836.4 MHz; Duty Cycle: 1:1
Medium: HSL_850 Medium parameters used: $f = 836.4$ MHz; $\sigma = 0.925$ S/m; $\epsilon_r = 41.43$; $\rho = 1000$ kg/m³

Ambient Temperature : 23.2 °C; Liquid Temperature : 22.9 °C

DASY5 Configuration:

- Probe: EX3DV4 - SN3935; ConvF(10.31, 10.31, 10.31); Calibrated: 2020.5.27
- Sensor-Surface: 1.4mm (Mechanical Surface Detection)
- Electronics: DAE4 Sn1358; Calibrated: 2020.4.28
- Phantom: SAM1; Type: SAM; Serial: TP-1697
- Measurement SW: DASY52, Version 52.10 (4); SEMCAD X Version 14.6.14 (7483)

Area Scan (71x71x1): Interpolated grid: dx=1.500 mm, dy=1.500 mm

Maximum value of SAR (interpolated) = 1.01 W/kg

Zoom Scan (5x5x7)/Cube 0: Measurement grid: dx=8mm, dy=8mm, dz=5mm

Reference Value = 13.90 V/m; Power Drift = 0.08 dB

Peak SAR (extrapolated) = 1.51 W/kg

SAR(1 g) = 0.677 W/kg; SAR(10 g) = 0.373 W/kg

Maximum value of SAR (measured) = 1.18 W/kg

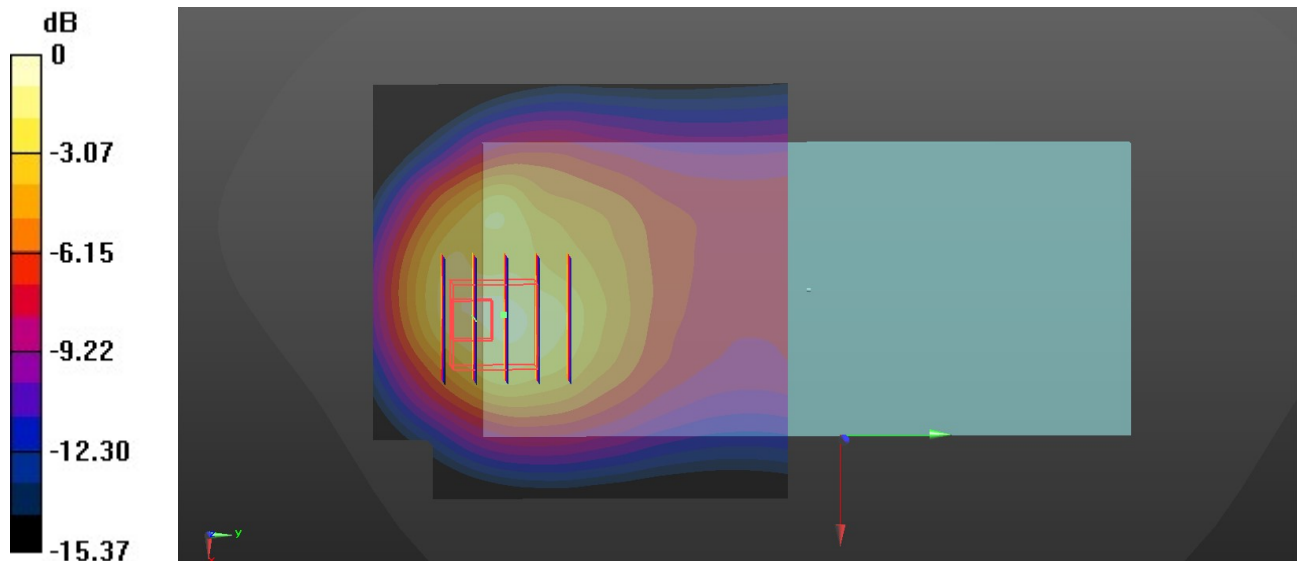

0 dB = 1.18 W/kg = 0.72 dBW/kg

40_LTE Band 2-LAT_20M_1RB_0offset_Back_5mm_Ch18900

Communication System: UID 0, LTE-FDD (0); Frequency: 1880 MHz; Duty Cycle: 1:1
Medium: HSL_1900 Medium parameters used: $f = 1880$ MHz; $\sigma = 1.451$ S/m; $\epsilon_r = 40.099$; $\rho = 1000$ kg/m³

Ambient Temperature : 23.2 °C; Liquid Temperature : 22.7 °C

DASY5 Configuration:

- Probe: EX3DV4 - SN3935; ConvF(8.35, 8.35, 8.35); Calibrated: 2020.5.27
- Sensor-Surface: 1.4mm (Mechanical Surface Detection)
- Electronics: DAE4 Sn1358; Calibrated: 2020.4.28
- Phantom: SAM1; Type: SAM; Serial: TP-1697
- Measurement SW: DASY52, Version 52.10 (4); SEMCAD X Version 14.6.14 (7483)

Area Scan (71x81x1): Interpolated grid: $dx=1.500$ mm, $dy=1.500$ mm
Maximum value of SAR (interpolated) = 0.583 W/kg

Zoom Scan (5x5x7)/Cube 0: Measurement grid: $dx=8$ mm, $dy=8$ mm, $dz=5$ mm
Reference Value = 3.181 V/m; Power Drift = 0.09 dB
Peak SAR (extrapolated) = 1.03 W/kg
SAR(1 g) = 0.507 W/kg; SAR(10 g) = 0.237 W/kg
Maximum value of SAR (measured) = 0.602 W/kg

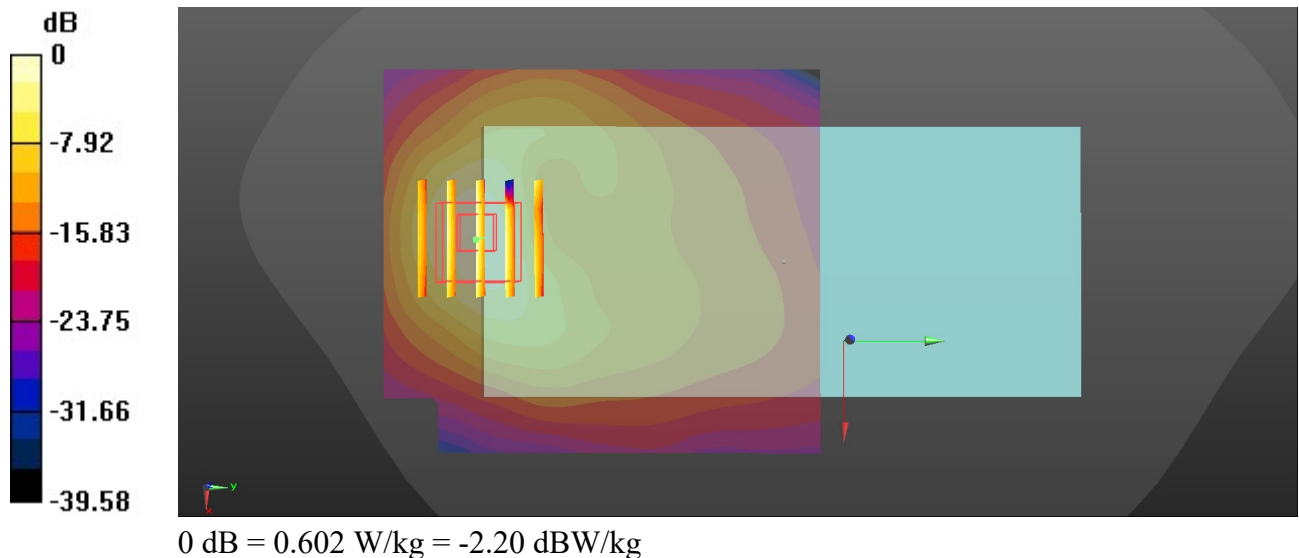

41_LTE Band 5-LAT_10M_QPSK_1RB_0Offset_Back_5mm_Ch20525

Communication System: UID 0, LTE-FDD (0); Frequency: 836.5 MHz; Duty Cycle: 1:1
Medium: HSL_850 Medium parameters used: $f = 836.5$ MHz; $\sigma = 0.925$ S/m; $\epsilon_r = 41.429$; $\rho = 1000$ kg/m³

Ambient Temperature : 23.2 °C; Liquid Temperature : 22.9 °C

DASY5 Configuration:

- Probe: EX3DV4 - SN3935; ConvF(10.31, 10.31, 10.31); Calibrated: 2020.5.27
- Sensor-Surface: 1.4mm (Mechanical Surface Detection)
- Electronics: DAE4 Sn1358; Calibrated: 2020.4.28
- Phantom: SAM1; Type: SAM; Serial: TP-1697
- Measurement SW: DASY52, Version 52.10 (4); SEMCAD X Version 14.6.14 (7483)

Area Scan (71x81x1): Interpolated grid: dx=1.500 mm, dy=1.500 mm

Maximum value of SAR (interpolated) = 1.006 W/kg

Zoom Scan (5x5x7)/Cube 0: Measurement grid: dx=8mm, dy=8mm, dz=5mm

Reference Value = 20.24 V/m; Power Drift = 0.05 dB

Peak SAR (extrapolated) = 1.598 W/kg

SAR(1 g) = 0.645 W/kg; SAR(10 g) = 0.408 W/kg

Maximum value of SAR (measured) = 0.893 W/kg

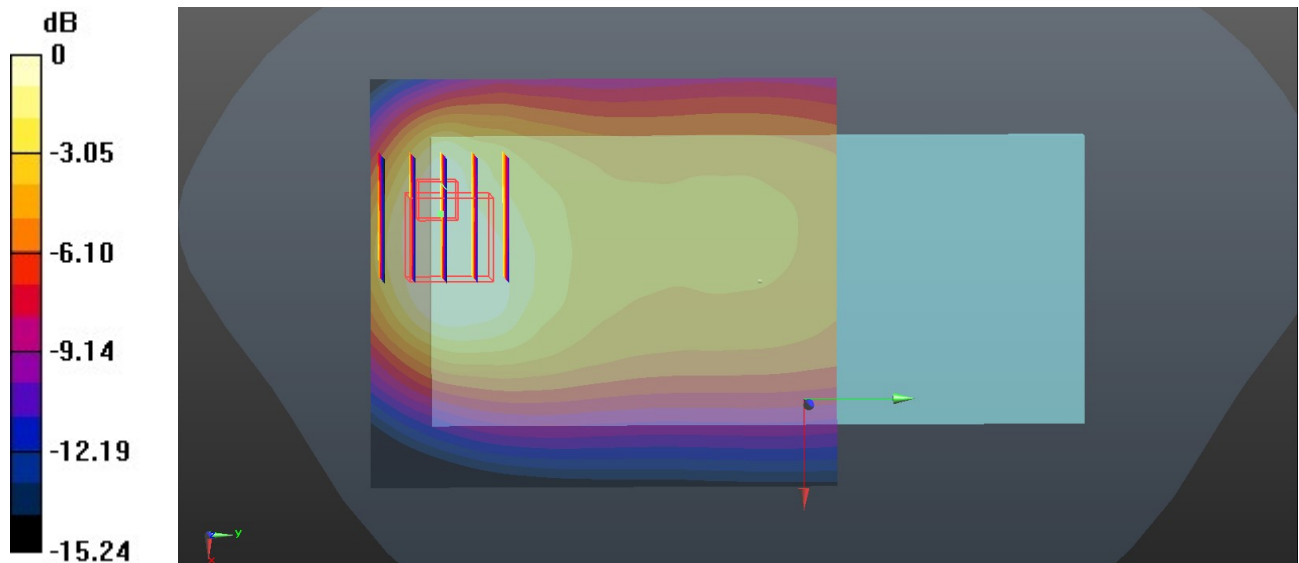

0 dB = 0.893 W/kg = -0.49 dBW/kg

42_LTE Band 12_10M_1RB_0Offset_Back_5mm_Ch23095

Communication System: UID 0, LTE-FDD (0); Frequency: 707.5 MHz; Duty Cycle: 1:1
Medium: HSL_750 Medium parameters used: $f = 707.5$ MHz; $\sigma = 0.909$ S/m; $\epsilon_r = 42.036$; $\rho = 1000$ kg/m³

Ambient Temperature : 23.3 °C; Liquid Temperature : 22.8 °C

DASY5 Configuration:

- Probe: EX3DV4 - SN3935; ConvF(10.58, 10.58, 10.58); Calibrated: 2020.5.27
- Sensor-Surface: 1.4mm (Mechanical Surface Detection)
- Electronics: DAE4 Sn1358; Calibrated: 2020.4.28
- Phantom: SAM1; Type: SAM; Serial: TP-1697
- Measurement SW: DASY52, Version 52.10 (4); SEMCAD X Version 14.6.14 (7483)

Area Scan (71x81x1): Interpolated grid: dx=1.500 mm, dy=1.500 mm

Maximum value of SAR (interpolated) = 0.491 W/kg

Zoom Scan (5x5x7)/Cube 0: Measurement grid: dx=8mm, dy=8mm, dz=5mm

Reference Value = 19.66 V/m; Power Drift = 0.05 dB

Peak SAR (extrapolated) = 0.933 W/kg

SAR(1 g) = 0.440 W/kg; SAR(10 g) = 0.257 W/kg

Maximum value of SAR (measured) = 0.553 W/kg

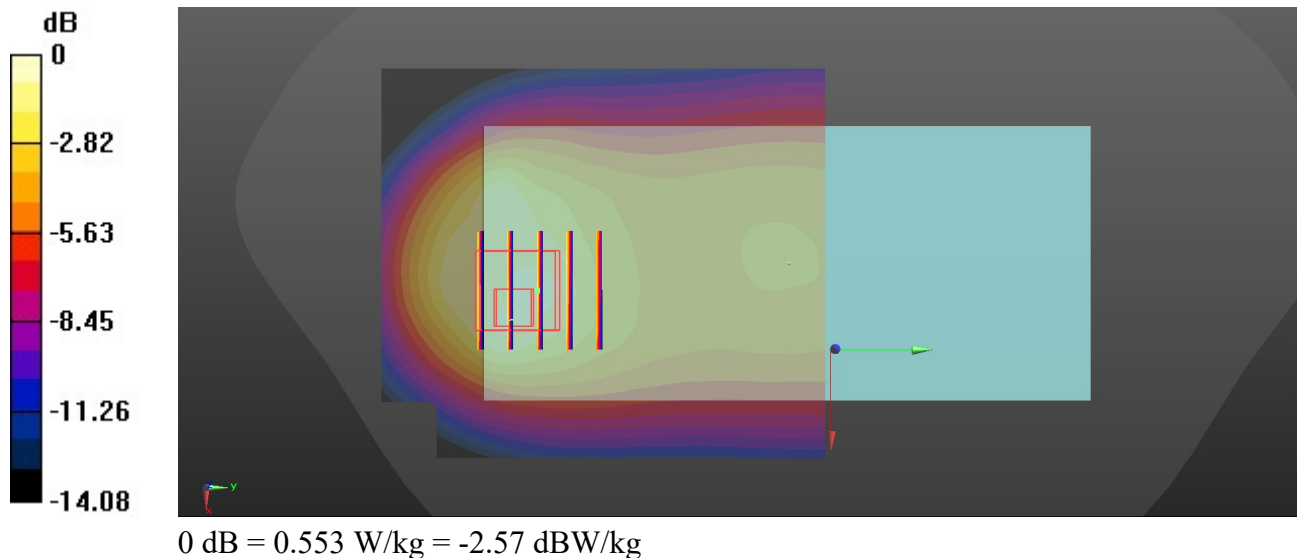

43_LTE Band 13_10M_1RB_0offset_Back_5mm_Ch23230

Communication System: UID 0, LTE-FDD (0); Frequency: 782 MHz; Duty Cycle: 1:1
Medium: HSL_750 Medium parameters used: $f = 782 \text{ MHz}$; $\sigma = 0.933 \text{ S/m}$; $\epsilon_r = 41.841$; $\rho = 1000 \text{ kg/m}^3$

Ambient Temperature : 23.3 °C; Liquid Temperature : 22.8 °C

DASY5 Configuration:

- Probe: EX3DV4 - SN3935; ConvF(10.58, 10.58, 10.58); Calibrated: 2020.5.27
- Sensor-Surface: 1.4mm (Mechanical Surface Detection)
- Electronics: DAE4 Sn1358; Calibrated: 2020.4.28
- Phantom: SAM1; Type: SAM; Serial: TP-1697
- Measurement SW: DASY52, Version 52.10 (4); SEMCAD X Version 14.6.14 (7483)

Area Scan (71x81x1): Interpolated grid: $dx=1.500 \text{ mm}$, $dy=1.500 \text{ mm}$

Maximum value of SAR (interpolated) = 0.997 W/kg

Zoom Scan (5x5x7)/Cube 0: Measurement grid: $dx=8\text{mm}$, $dy=8\text{mm}$, $dz=5\text{mm}$

Reference Value = 17.19 V/m; Power Drift = -0.15 dB

Peak SAR (extrapolated) = 1.21 W/kg

SAR(1 g) = 0.585 W/kg; SAR(10 g) = 0.333 W/kg

Maximum value of SAR (measured) = 0.745 W/kg

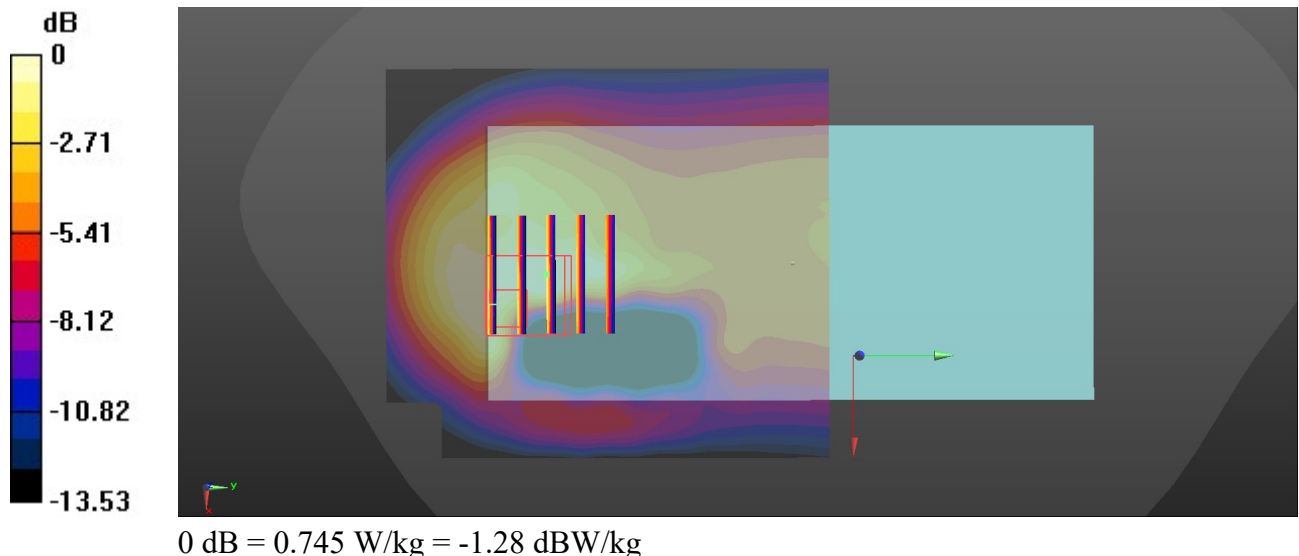

44_LTE Band 7_20M_QPSK_50RB_0Offset_Back_5mm_Ch21100

Communication System: UID 0, LTE-FDD (0); Frequency: 2535 MHz; Duty Cycle: 1:1
Medium: HSL_2600 Medium parameters used: $f = 2535$ MHz; $\sigma = 1.911$ S/m; $\epsilon_r = 39.047$; $\rho = 1000$ kg/m³

Ambient Temperature : 23.3 °C; Liquid Temperature : 22.7 °C

DASY5 Configuration:

- Probe: EX3DV4 - SN3935; ConvF(7.43, 7.43, 7.43); Calibrated: 2020.5.27
- Sensor-Surface: 1.4mm (Mechanical Surface Detection)
- Electronics: DAE4 Sn1358; Calibrated: 2020.4.28
- Phantom: SAM1; Type: SAM; Serial: TP-1697
- Measurement SW: DASY52, Version 52.10 (4); SEMCAD X Version 14.6.14 (7483)

Area Scan (91x101x1): Interpolated grid: dx=1.200 mm, dy=1.200 mm
Maximum value of SAR (interpolated) = 0.645 W/kg

Zoom Scan (7x7x7)/Cube 0: Measurement grid: dx=5mm, dy=5mm, dz=5mm
Reference Value = 1.180 V/m; Power Drift = 0.09 dB
Peak SAR (extrapolated) = 0.991 W/kg
SAR(1 g) = 0.473 W/kg; SAR(10 g) = 0.221 W/kg
Maximum value of SAR (measured) = 0.627 W/kg

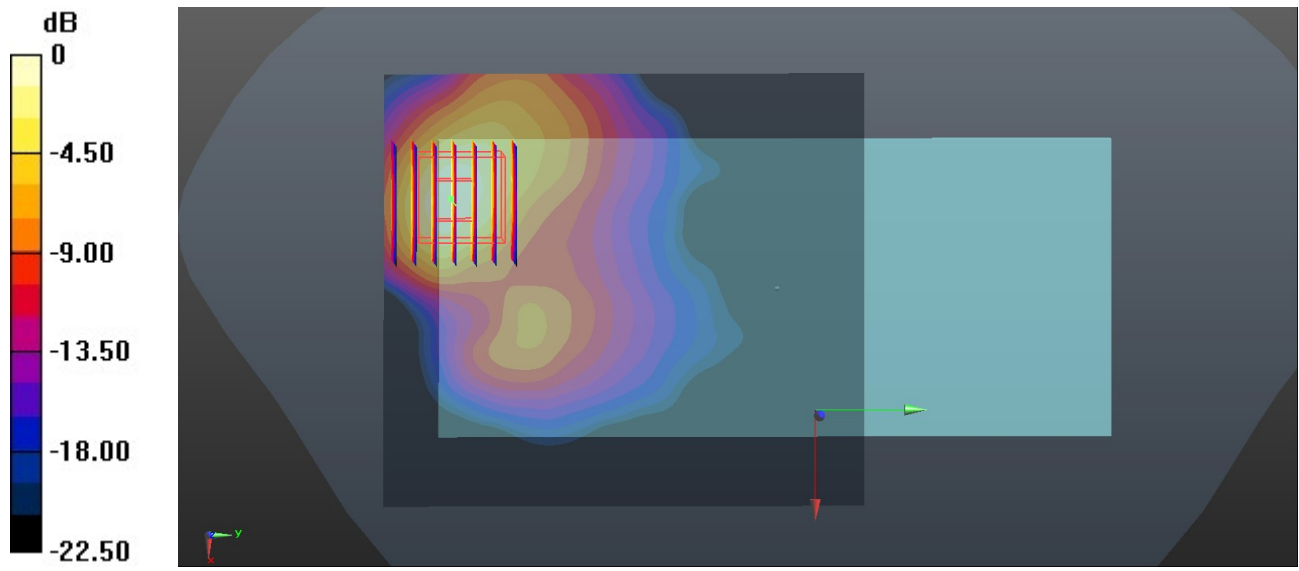

0 dB = 0.627 W/kg = -2.03 dBW/kg

45_LTE Band 66_20M_1RB_0offset_Back_5mm_Ch132322

Communication System: UID 0, LTE-FDD (0); Frequency: 1745 MHz; Duty Cycle: 1:1
Medium: HSL_1750 Medium parameters used: $f = 1745$ MHz; $\sigma = 1.343$ S/m; $\epsilon_r = 40.397$; $\rho = 1000$ kg/m³

Ambient Temperature : 23.1 °C; Liquid Temperature : 22.6 °C

DASY5 Configuration:

- Probe: EX3DV4 - SN3935; ConvF(8.6, 8.6, 8.6); Calibrated: 2020.5.27
- Sensor-Surface: 1.4mm (Mechanical Surface Detection)
- Electronics: DAE4 Sn1358; Calibrated: 2020.4.28
- Phantom: SAM1; Type: SAM; Serial: TP-1697
- Measurement SW: DASY52, Version 52.10 (4); SEMCAD X Version 14.6.14 (7483)

Area Scan (71x81x1): Interpolated grid: dx=1.500 mm, dy=1.500 mm
Maximum value of SAR (interpolated) = 0.508 W/kg

Zoom Scan (5x5x7)/Cube 0: Measurement grid: dx=8mm, dy=8mm, dz=5mm
Reference Value = 2.856 V/m; Power Drift = 0.05 dB
Peak SAR (extrapolated) = 0.796 W/kg
SAR(1 g) = 0.424 W/kg; SAR(10 g) = 0.198 W/kg
Maximum value of SAR (measured) = 0.497 W/kg

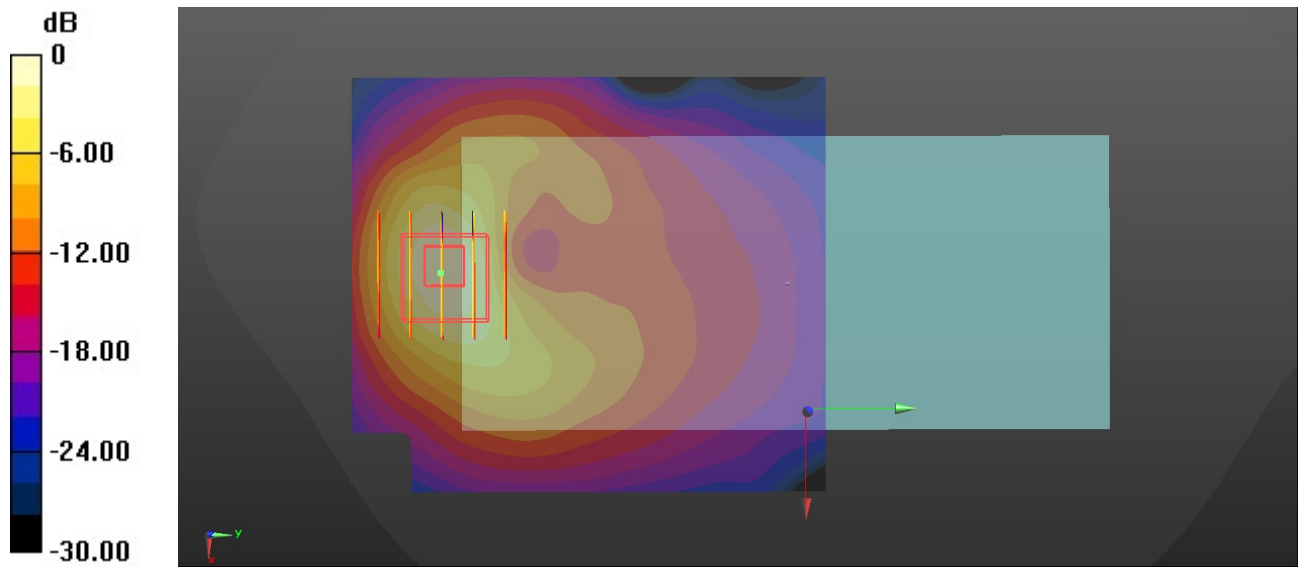

0 dB = 0.497 W/kg = -3.04 dBW/kg

46_FR 1 n2_20M_1RB_1Offset_Back_Ant 1_5mm_Ch376000

Communication System: UID 0, 5G NR (0); Frequency: 1880 MHz; Duty Cycle: 1:1
 Medium: HSL_1900 Medium parameters used: $f = 1880$ MHz; $\sigma = 1.451$ S/m; $\epsilon_r = 40.099$; $\rho = 1000$ kg/m³
 Ambient Temperature : 23.2 °C; Liquid Temperature : 22.7 °C

DASY5 Configuration:

- Probe: EX3DV4 - SN3935; ConvF(8.35, 8.35, 8.35); Calibrated: 2020.5.27
- Sensor-Surface: 1.4mm (Mechanical Surface Detection)
- Electronics: DAE4 Sn1358; Calibrated: 2020.4.28
- Phantom: SAM1; Type: SAM; Serial: TP-1697
- Measurement SW: DASY52, Version 52.10 (4); SEMCAD X Version 14.6.14 (7483)

Area Scan (71x71x1): Interpolated grid: dx=1.500 mm, dy=1.500 mm
 Maximum value of SAR (interpolated) = 0.970 W/kg

Zoom Scan (5x5x7)/Cube 0: Measurement grid: dx=8mm, dy=8mm, dz=5mm
 Reference Value = 3.640 V/m; Power Drift = 0.08 dB
 Peak SAR (extrapolated) = 1.44 W/kg
SAR(1 g) = 0.731 W/kg; SAR(10 g) = 0.356 W/kg
 Maximum value of SAR (measured) = 1.16 W/kg

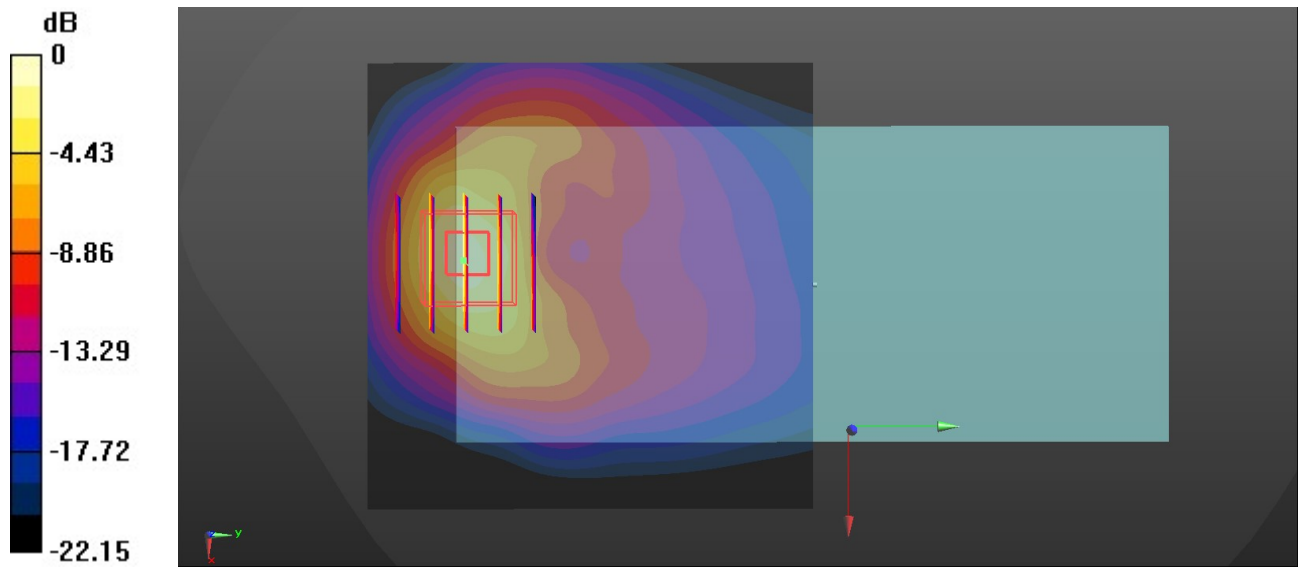

0 dB = 1.16 W/kg = 0.64 dBW/kg

47_FR1 n5_20M_1RB_1Offset_Back_Ant 1_5mm_Ch167300

Communication System: UID 0, 5G NR (0); Frequency: 836.5 MHz; Duty Cycle: 1:1
Medium: HSL_850 Medium parameters used: $f = 836.5$ MHz; $\sigma = 0.925$ S/m; $\epsilon_r = 41.429$; $\rho = 1000$ kg/m³
Ambient Temperature : 23.2 °C; Liquid Temperature : 22.9 °C

DASY5 Configuration:

- Probe: EX3DV4 - SN3935; ConvF(10.31, 10.31, 10.31); Calibrated: 2020.5.27
- Sensor-Surface: 1.4mm (Mechanical Surface Detection)
- Electronics: DAE4 Sn1358; Calibrated: 2020.4.28
- Phantom: SAM1; Type: SAM; Serial: TP-1697
- Measurement SW: DASY52, Version 52.10 (4); SEMCAD X Version 14.6.14 (7483)

Area Scan (71x71x1): Interpolated grid: $dx=1.500$ mm, $dy=1.500$ mm
Maximum value of SAR (interpolated) = 0.916 W/kg

Zoom Scan (6x6x7)/Cube 0: Measurement grid: $dx=8$ mm, $dy=8$ mm, $dz=5$ mm
Reference Value = 14.83 V/m; Power Drift = 0.05 dB
Peak SAR (extrapolated) = 1.38 W/kg
SAR(1 g) = 0.623 W/kg; SAR(10 g) = 0.348 W/kg
Maximum value of SAR (measured) = 1.09 W/kg

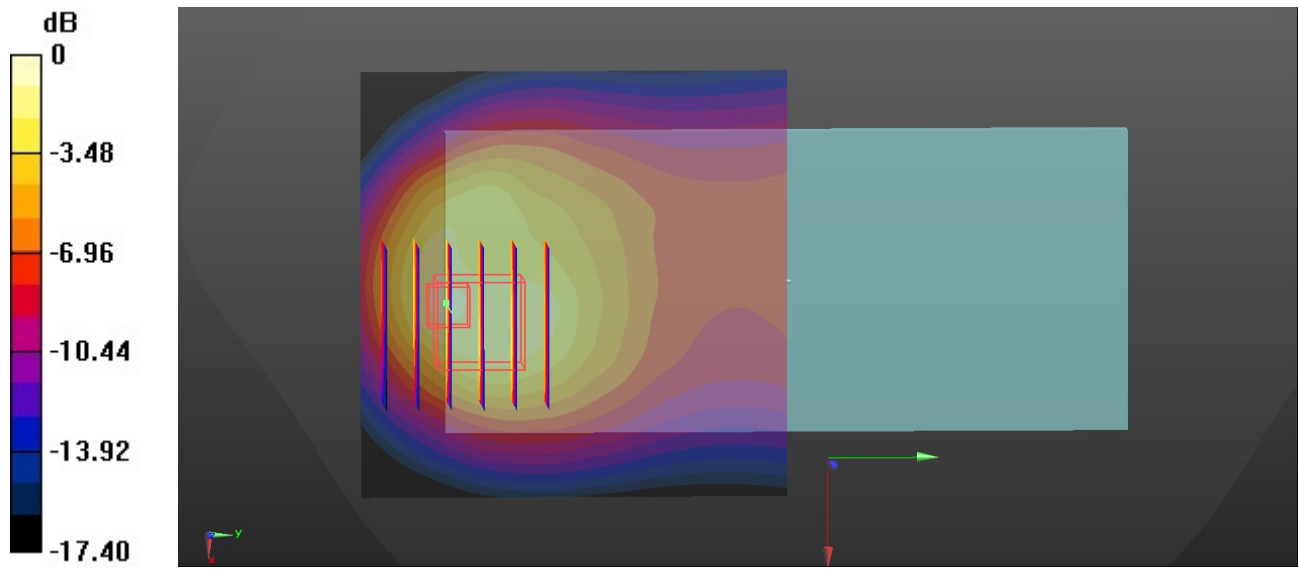

0 dB = 1.09 W/kg = 0.37 dBW/kg

48_FR1 n66_20M_50RB_28Offset_Back_Ant 1_5mm_Ch349000

Communication System: UID 0, 5G NR (0); Frequency: 1745 MHz; Duty Cycle: 1:1
Medium: HSL_1750 Medium parameters used: $f = 1745$ MHz; $\sigma = 1.345$ S/m; $\epsilon_r = 40397$; $\rho = 1000$ kg/m³
Ambient Temperature : 23.1 °C; Liquid Temperature : 22.6 °C

DASY5 Configuration:

- Probe: EX3DV4 - SN3935; ConvF(8.6, 8.6, 8.6); Calibrated: 2020.5.27
- Sensor-Surface: 1.4mm (Mechanical Surface Detection)
- Electronics: DAE4 Sn1358; Calibrated: 2020.4.28
- Phantom: SAM1; Type: SAM; Serial: TP-1697
- Measurement SW: DASY52, Version 52.10 (4); SEMCAD X Version 14.6.14 (7483)

Area Scan (71x71x1): Interpolated grid: dx=1.500 mm, dy=1.500 mm
Maximum value of SAR (interpolated) = 0.882 W/kg

Zoom Scan (5x5x7)/Cube 0: Measurement grid: dx=8mm, dy=8mm, dz=5mm
Reference Value = 4.226 V/m; Power Drift = 0.15 dB
Peak SAR (extrapolated) = 1.24 W/kg
SAR(1 g) = 0.639 W/kg; SAR(10 g) = 0.319 W/kg
Maximum value of SAR (measured) = 0.983 W/kg

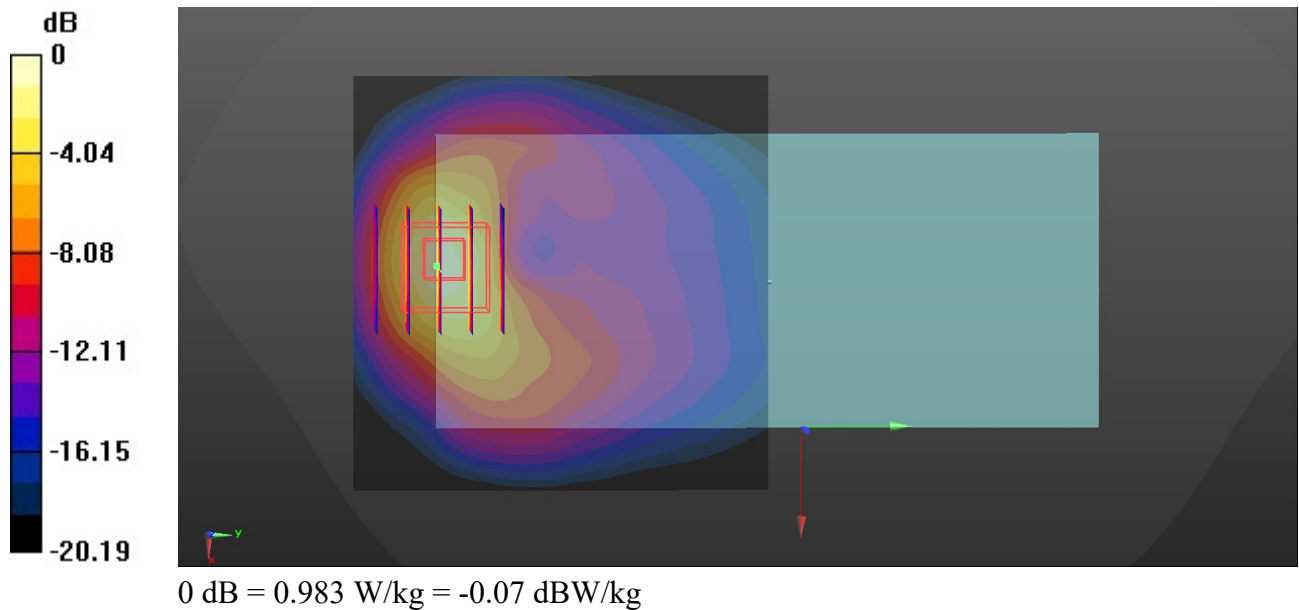

49_WLAN2.4GHz_802.11b 1Mbps_Back_5mm_Ch1

Communication System: UID 0, 802.11b (0); Frequency: 2412 MHz; Duty Cycle: 1:1
Medium: HSL_2450 Medium parameters used: $f = 2412$ MHz; $\sigma = 1.814$ S/m; $\epsilon_r = 39.09$; $\rho = 1000$ kg/m³
Ambient Temperature : 23.4 °C; Liquid Temperature : 22.6 °C

DASY5 Configuration:

- Probe: EX3DV4 - SN3935; ConvF(7.6, 7.6, 7.6); Calibrated: 2020.5.27
- Sensor-Surface: 1.4mm (Mechanical Surface Detection)
- Electronics: DAE4 Sn1358; Calibrated: 2020.4.28
- Phantom: SAM1; Type: SAM; Serial: TP-1697
- Measurement SW: DASY52, Version 52.10 (4); SEMCAD X Version 14.6.14 (7483)

Area Scan (91x81x1): Interpolated grid: dx=1.200 mm, dy=1.200 mm
Maximum value of SAR (interpolated) = 2.31 W/kg

Zoom Scan (7x8x7)/Cube 0: Measurement grid: dx=5mm, dy=5mm, dz=5mm
Reference Value = 9.497 V/m; Power Drift = -0.11 dB
Peak SAR (extrapolated) = 3.31 W/kg
SAR(1 g) = 1.01 W/kg; SAR(10 g) = 0.478 W/kg
Maximum value of SAR (measured) = 2.25 W/kg

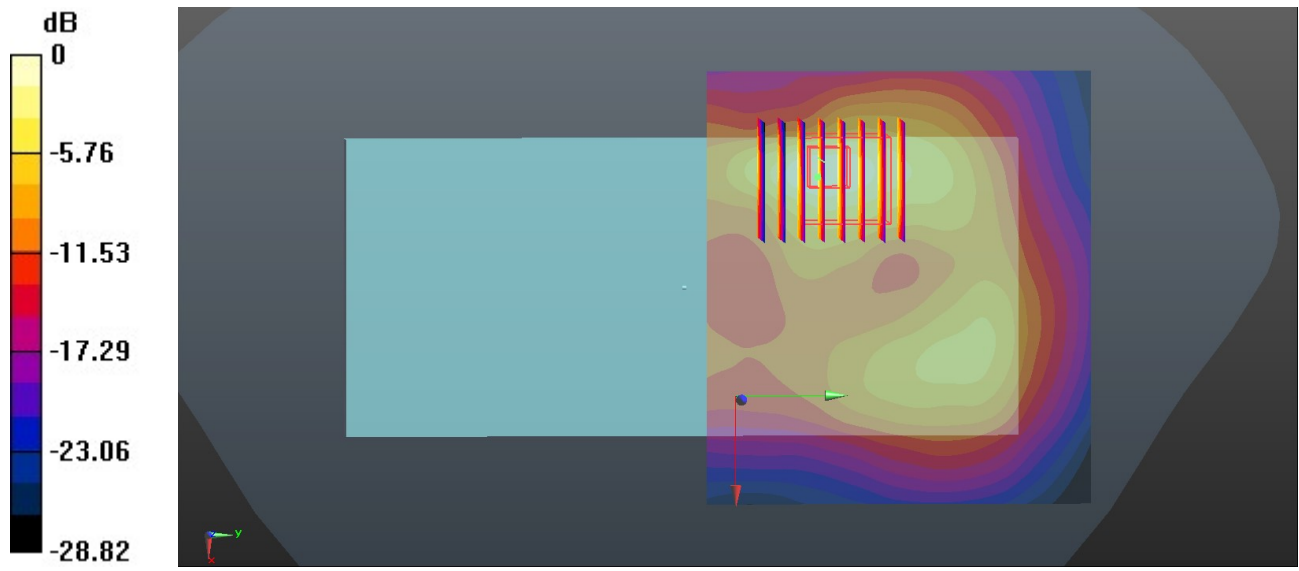

0 dB = 2.25 W/kg = 3.52 dBW/kg

50_WLAN5GHz_802.11a_6Mbps_Back_5mm_Ch40

Communication System: UID 0, 802.11a (0); Frequency: 5200 MHz; Duty Cycle: 1:1.014
Medium: HSL_5000 Medium parameters used: $f = 5200$ MHz; $\sigma = 4.626$ S/m; $\epsilon_r = 37.086$; $\rho = 1000$ kg/m³

Ambient Temperature : 23.4 °C; Liquid Temperature : 22.8 °C

DASY5 Configuration:

- Probe: EX3DV4 - SN3935; ConvF(5.04, 5.04, 5.04); Calibrated: 2020.5.27
- Sensor-Surface: 1.4mm (Mechanical Surface Detection)
- Electronics: DAE4 Sn1358; Calibrated: 2020.4.28
- Phantom: SAM1; Type: SAM; Serial: TP-1697
- Measurement SW: DASY52, Version 52.10 (4); SEMCAD X Version 14.6.14 (7483)

Area Scan (101x101x1): Interpolated grid: dx=1.000 mm, dy=1.000 mm
Maximum value of SAR (interpolated) = 2.64 W/kg

Zoom Scan (9x9x7)/Cube 0: Measurement grid: dx=4mm, dy=4mm, dz=1.4mm
Reference Value = 1.846 V/m; Power Drift = 0.09 dB
Peak SAR (extrapolated) = 3.89 W/kg
SAR(1 g) = 1 W/kg; SAR(10 g) = 0.237 W/kg
Maximum value of SAR (measured) = 2.50 W/kg

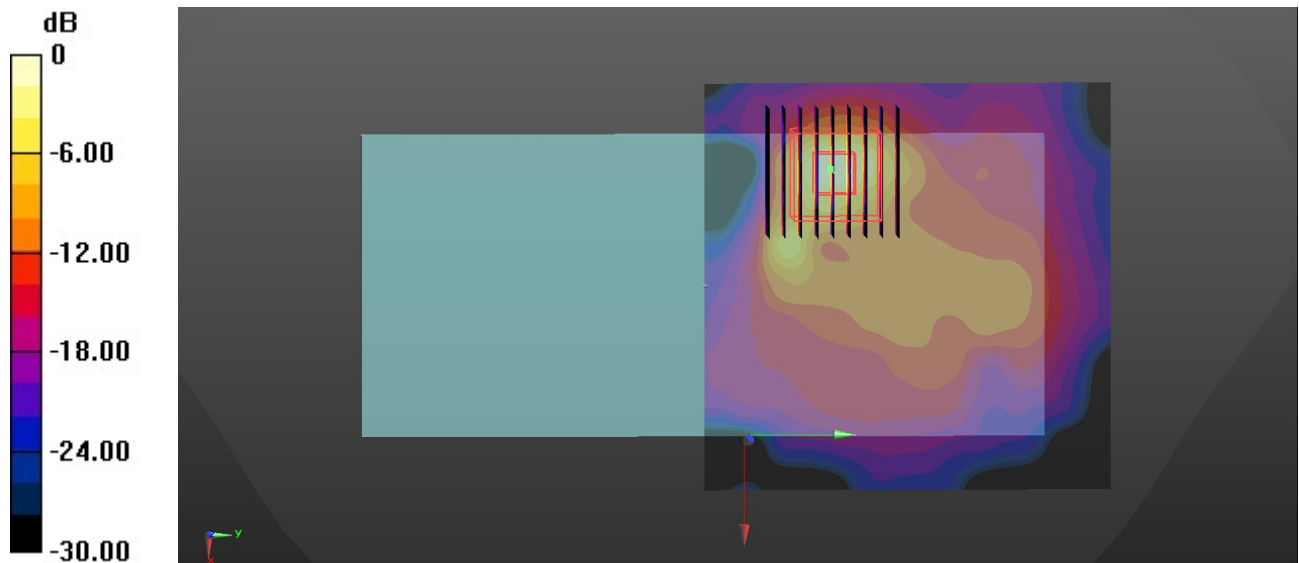

0 dB = 2.50 W/kg = 3.98 dBW/kg

51_WLAN5GHz_802.11a_6Mbps_Back_5mm_Ch56

Communication System: UID 0, 802.11a (0); Frequency: 5280 MHz; Duty Cycle: 1:1.014
Medium: HSL_5000 Medium parameters used: $f = 5280$ MHz; $\sigma = 4.711$ S/m; $\epsilon_r = 36.95$; $\rho = 1000$ kg/m³
Ambient Temperature : 23.4 °C; Liquid Temperature : 22.8 °C

DASY5 Configuration:

- Probe: EX3DV4 - SN3935; ConvF(5.04, 5.04, 5.04); Calibrated: 2020.5.27
- Sensor-Surface: 1.4mm (Mechanical Surface Detection)
- Electronics: DAE4 Sn1358; Calibrated: 2020.4.28
- Phantom: SAM1; Type: SAM; Serial: TP-1697
- Measurement SW: DASY52, Version 52.10 (4); SEMCAD X Version 14.6.14 (7483)

Area Scan (101x101x1): Interpolated grid: dx=1.000 mm, dy=1.000 mm
Maximum value of SAR (interpolated) = 2.00 W/kg

Zoom Scan (9x9x7)/Cube 0: Measurement grid: dx=4mm, dy=4mm, dz=1.4mm
Reference Value = 2.452 V/m; Power Drift = -0.02 dB
Peak SAR (extrapolated) = 4.08 W/kg
SAR(1 g) = 0.919 W/kg; SAR(10 g) = 0.223 W/kg
Maximum value of SAR (measured) = 2.30 W/kg

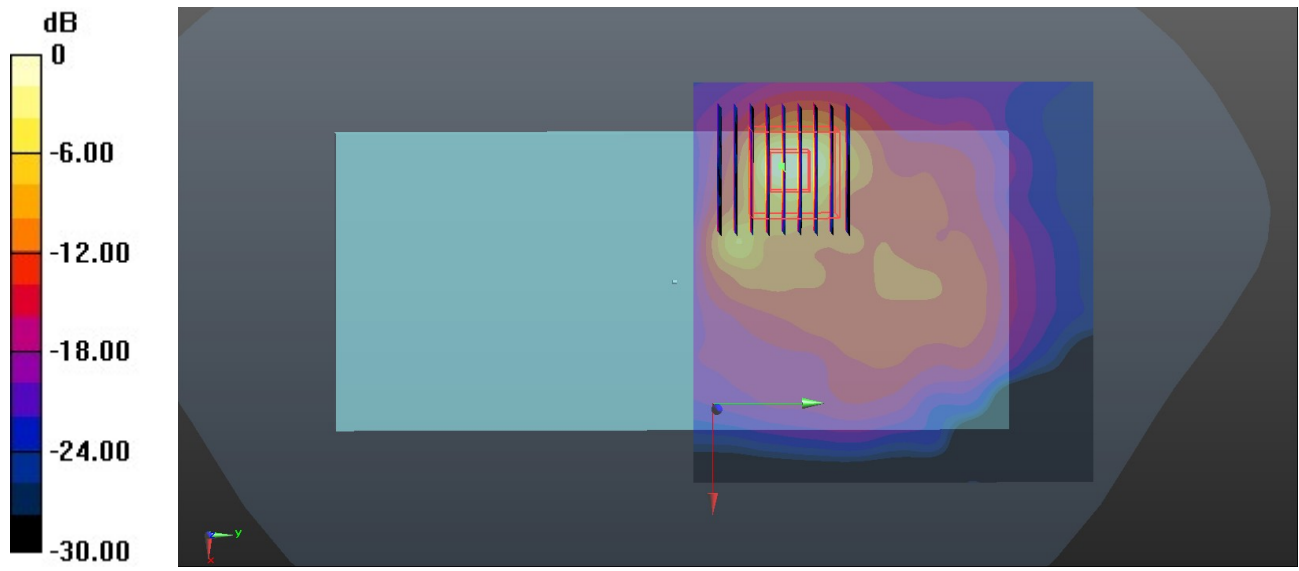

0 dB = 2.30 W/kg = 3.62 dBW/kg

52_WLAN5GHz_802.11a_6Mbps_Back_5mm_Ch116

Communication System: UID 0, 802.11a (0); Frequency: 5580 MHz; Duty Cycle: 1:1.014
Medium: HSL_5000 Medium parameters used: $f = 5580$ MHz; $\sigma = 5.007$ S/m; $\epsilon_r = 36.525$; $\rho = 1000$ kg/m³

Ambient Temperature : 23.3 °C; Liquid Temperature : 22.6 °C

DASY5 Configuration:

- Probe: EX3DV4 - SN3935; ConvF(4.76, 4.76, 4.76); Calibrated: 2020.5.27
- Sensor-Surface: 1.4mm (Mechanical Surface Detection)
- Electronics: DAE4 Sn1358; Calibrated: 2020.4.28
- Phantom: SAM1; Type: SAM; Serial: TP-1697
- Measurement SW: DASY52, Version 52.10 (4); SEMCAD X Version 14.6.14 (7483)

Area Scan (101x101x1): Interpolated grid: dx=1.000 mm, dy=1.000 mm
Maximum value of SAR (interpolated) = 2.317 W/kg

Zoom Scan (8x8x7)/Cube 0: Measurement grid: dx=4mm, dy=4mm, dz=1.4mm
Reference Value = 3.229 V/m; Power Drift = 0.05 dB
Peak SAR (extrapolated) = 4.365 W/kg
SAR(1 g) = 0.924 W/kg; SAR(10 g) = 0.235 W/kg
Maximum value of SAR (measured) = 2.287 W/kg

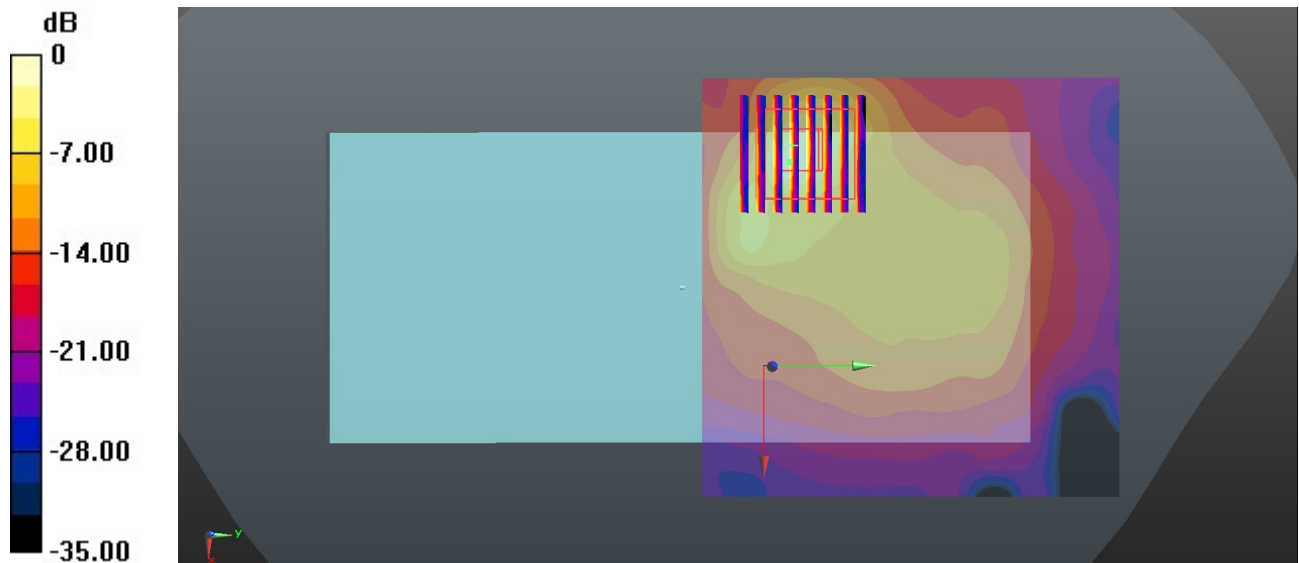

0 dB = 2.287 W/kg = 3.59 dBW/kg