



FCC RF Test Report

APPLICANT : Motorola Mobility LLC
EQUIPMENT : Mobile Cellular Phone
BRAND NAME : Motorola
MODEL NAME : XT2073-2
FCC ID : IHDT56ZA1
STANDARD : FCC Part 15 Subpart C §15.247
CLASSIFICATION : (DTS) Digital Transmission System

The product was received on Jan. 17, 2020 and testing was completed on Apr. 29, 2020. We, Sporton International (Kunshan) Inc., would like to declare that the tested sample has been evaluated in accordance with the test procedures and has been in compliance with the applicable technical standards.

This report contains data that were produced under subcontract by Laboratory SPORTON INTERNATIONAL INC.

The test results in this report apply exclusively to the tested model / sample. Without written approval of Sporton International (Kunshan) Inc., the test report shall not be reproduced except in full.

Reviewed by: Jason Jia / Supervisor

Approved by: James Huang / Manager



Sporton International (Kunshan) Inc.

**No. 1098, Pengxi North Road, Kunshan Economic Development Zone Jiangsu Province 215300
People's Republic of China**



TABLE OF CONTENTS

REVISION HISTORY..... 3

SUMMARY OF TEST RESULT 4

1 GENERAL DESCRIPTION 5

 1.1 Applicant 5

 1.2 Manufacturer 5

 1.3 Product Feature of Equipment Under Test..... 5

 1.4 Product Specification of Equipment Under Test..... 6

 1.5 Modification of EUT 6

 1.6 Testing Location 6

 1.7 Test Software..... 7

 1.8 Applicable Standards..... 7

 1.9 Specification of Accessory..... 7

2 TEST CONFIGURATION OF EQUIPMENT UNDER TEST 9

 2.1 Carrier Frequency and Channel 9

 2.2 Test Mode 10

 2.3 Connection Diagram of Test System..... 11

 2.4 Support Unit used in test configuration and system 12

 2.5 EUT Operation Test Setup 12

 2.6 Measurement Results Explanation Example..... 12

3 TEST RESULT 13

 3.1 6dB Bandwidth Measurement 13

 3.2 Output Power Measurement..... 15

 3.3 Power Spectral Density Measurement 16

 3.4 Conducted Band Edges and Spurious Emission Measurement 18

 3.5 Radiated Band Edges and Spurious Emission Measurement 28

 3.6 AC Conducted Emission Measurement..... 32

 3.7 Antenna Requirements 34

4 LIST OF MEASURING EQUIPMENT 35

5 UNCERTAINTY OF EVALUATION 36

APPENDIX A. CONDUCTED TEST RESULTS

APPENDIX B. AC CONDUCTED EMISSION TEST RESULT

APPENDIX C. RADIATED SPURIOUS EMISSION

APPENDIX D. DUTY CYCLE PLOTS

APPENDIX E. SETUP PHOTOGRAPHS



SUMMARY OF TEST RESULT

Report Section	FCC Rule	Description	Limit	Result	Remark
3.1	15.247(a)(2)	6dB Bandwidth	≥ 0.5MHz	Pass	-
3.2	15.247(b)	Power Output Measurement	≤ 30dBm	Pass	-
3.3	15.247(e)	Power Spectral Density	≤ 8dBm/3kHz	Pass	-
3.4	15.247(d)	Conducted Band Edges	≤ 20dBc	Pass	-
		Conducted Spurious Emission		Pass	-
3.5	15.247(d)	Radiated Band Edges and Radiated Spurious Emission	15.209(a) & 15.247(d)	Pass	Under limit 3.17 dB at 2389.950 MHz
3.6	15.207	AC Conducted Emission	15.207(a)	Pass	Under limit 10.20 dB at 0.570 MHz
3.7	15.203 & 15.247(b)	Antenna Requirement	N/A	Pass	-

Declaration of Conformity:
The test results with all measurement uncertainty excluded are presented in accordance with the regulation limits or requirements declared by manufacturers.
Comments and Explanations:
The declared of product specification for EUT presented in the report are provided by the manufacturer, and the manufacturer takes all the responsibilities for the accuracy of product specification.



1 General Description

1.1 Applicant

Motorola Mobility LLC
222 W, Merchandise Mart Plaza, Chicago IL 60654 USA

1.2 Manufacturer

Motorola Mobility LLC
222 W, Merchandise Mart Plaza, Chicago IL 60654 USA

1.3 Product Feature of Equipment Under Test

Product Feature	
Equipment	Mobile Cellular Phone
Brand Name	Motorola
Model Name	XT2073-2
FCC ID	IHDT56ZA1
EUT supports Radios application	GSM/WCDMA/LTE WLAN 2.4GHz 802.11b/g/n HT20 Bluetooth BR/EDR/LE FM Receiver and GNSS
HW Version	DVT2
SW Version	QPL30.50
IMEI Code	Conducted: 353597110104815/0 Conduction: 353596110006418/353596110006426 Radiation: 353596110012614/353596110012644
EUT Stage	Identical Prototype

Remark:

1. The above EUT's information was declared by manufacturer. Please refer to the specifications or user's manual for more detailed description.
2. There are two types of EUT, the sample 1 is dual SIM slot and the sample 2 is single SIM slot. We only choose sample 1 to perform full tests.



1.4 Product Specification of Equipment Under Test

Standards-related Product Specification	
Tx/Rx Channel Frequency Range	2412 MHz ~ 2462 MHz
Maximum (Peak) Output Power to antenna	802.11b : 20.13 dBm (0.1030 W) 802.11g : 23.12 dBm (0.2051 W) 802.11n HT20 : 23.34 dBm (0.2158 W)
Antenna Type / Gain	IPA Antenna type with gain -2.5 dBi
Type of Modulation	802.11b : DSSS (DBPSK / DQPSK / CCK) 802.11g/n : OFDM (BPSK / QPSK / 16QAM / 64QAM)

1.5 Modification of EUT

No modifications are made to the EUT during all test items.

1.6 Testing Location

Sporton International (Kunshan) Inc. is accredited to ISO/IEC 17025:2017 by American Association for Laboratory Accreditation with Certificate Number 5145.02.

Test Firm	Sporton International (Kunshan) Inc.		
Test Site Location	No. 1098, Pengxi North Road, Kunshan Economic Development Zone Jiangsu Province 215300 People's Republic of China TEL : +86-512-57900158 FAX : +86-512-57900958		
Test Site No.	Sporton Site No.	FCC Designation No.	FCC Test Firm Registration No.
	03CH06-KS TH01-KS	CN1257	314309

SPORTON INTERNATIONAL INC. is accredited to ISO 17025 by Taiwan Accreditation Foundation (TAF code : 1190) and under the FCC-recognized accredited testing laboratories by Mutual Recognition Agreement (MRA) in FCC Test.

Test Firm	SPORTON INTERNATIONAL INC.		
Test Site Location	No.52, Huaya 1st Rd., Guishan Dist. Taoyuan City Taiwan Tel: 886-3-327-3456 FAX: +886-3-327-0978		
Test Site No.	Sporton Site No.		
	CO05-HY		

Test data subcontracted: AC Conducted Emission in section 3.6 of this report.



1.7 Test Software

Item	Site	Manufacture	Name	Version
1.	03CH06-KS	AUDIX	E3	6.2009-8-24al
2.	CO05-HY	Rohde & Schwarz	EMC32 V10.30	N/A

1.8 Applicable Standards

According to the specifications of the manufacturer, the EUT must comply with the requirements of the following standards:

- ♦ 47 CFR Part 15 Subpart C §15.247
- ♦ FCC KDB 558074 D01 15.247 Meas Guidance v05r02
- ♦ ANSI C63.10-2013

Remark:

1. All test items were verified and recorded according to the standards and without any deviation during the test.
2. This EUT has also been tested and complied with the requirements of FCC Part 15, Subpart B, recorded in a separate test report.

1.9 Specification of Accessory

Specification of Accessory			
AC Adapter 1(US)	Brand Name	Motorola(Acbel)	Model Name SC-41
	Power Rating	I/P: 100-240 Vac, 300mA , O/P: 5Vdc, 2000mA	
AC Adapter 1(EU)	Brand Name	Motorola(Acbel)	Model Name SC-42
	Power Rating	I/P: 100-240 Vac, 300mA , O/P: 5Vdc, 2000mA	
AC Adapter 1(AR)	Brand Name	Motorola(Acbel)	Model Name SC-46
	Power Rating	I/P: 100-240 Vac, 300mA , O/P: 5Vdc, 2000mA	
AC Adapter 2(US)	Brand Name	Motorola(Chenyang)	Model Name SC-41
	Power Rating	I/P: 100-240 Vac, 300mA , O/P: 5Vdc, 2000mA	
AC Adapter 2(EU)	Brand Name	Motorola(Chenyang)	Model Name SC-42
	Power Rating	I/P: 100-240 Vac, 300mA , O/P: 5Vdc, 2000mA	
AC Adapter 2(AR)	Brand Name	Motorola(Chenyang)	Model Name SC-46
	Power Rating	I/P: 100-240 Vac, 300mA , O/P: 5Vdc, 2000mA	
AC Adapter 2(UK)	Brand Name	Motorola(Chenyang)	Model Name SC-43
	Power Rating	I/P: 100-240 Vac, 300mA , O/P: 5Vdc, 2000mA	



AC Adapter 3(Chile)	Brand Name	Motorola(Salom)	Model Name	SC-42
	Power Rating	I/P: 100-240 Vac, 300mA , O/P: 5Vdc, 2000mA		
AC Adapter 3 (BR) (Salom China build)	Brand Name	Motorola(Salom)	Model Name	SC-47
	Power Rating	I/P: 100-240 Vac, 300mA , O/P: 5Vdc, 2000mA		
AC Adapter 3 (BR) (Flex Brazil local build)	Brand Name	Motorola(Flex)	Model Name	SC-47
	Power Rating	I/P: 100-240 Vac, 300mA , O/P: 5Vdc, 2000mA		
AC Adapter 4 (BR) (Cliptech Brazil local build)	Brand Name	Motorola(Cliptech)	Model Name	SC-47
	Power Rating	I/P: 100-240 Vac, 300mA , O/P: 5Vdc, 2000mA		
Battery 1	Brand Name	Motorola (SCUD)	Model Name	JK50
	Power Rating	3.8Vdc, 4000mAh	Type	Li-ion, Polymer
Battery 2	Brand Name	Motorola (ATL)	Model Name	JK50
	Power Rating	3.8Vdc, 4000mAh	Type	Li-ion, Polymer
Earphone 1	Brand Name	Motorola (NEW LEADER)	Model Name	NLD-EM301K-01SF
	Signal Line Type	1.2 meter, non-shielded cable, without ferrite core		
Earphone 2	Brand Name	Motorola (Lianyun)	Model Name	MI181 (SH38C37773)
	Signal Line Type	1.1 meter, non-shielded cable, without ferrite core		
Earphone 3	Brand Name	Motorola (Cosonic)	Model Name	MI181 (SH38C44959)
	Signal Line Type	1.1 meter, non-shielded cable, without ferrite core		
USB Cable 1	Brand Name	Motorola (Saibao)	Model Name	SC18C24367
	Signal Line Type	1.0 meter, shielded cable, without ferrite core		
USB Cable 2	Brand Name	Motorola (Luxshare)	Model Name	SC18C24368
	Signal Line Type	1.0 meter, shielded cable, without ferrite core		
USB Cable 3	Brand Name	Motorola (Cabletech)	Model Name	SC18C49697
	Signal Line Type	1.0 meter, shielded cable, without ferrite core		
USB Cable 4	Brand Name	Motorola (I SHENG)	Model Name	SC18C28955
	Signal Line Type	1.0 meter, shielded cable, without ferrite core		



2 Test Configuration of Equipment Under Test

- a. The EUT has been associated with peripherals and configuration operated in a manner tended to maximize its emission characteristics in a typical application. Frequency range investigated: conduction emission (150 kHz to 30 MHz), radiation emission (9 kHz to the 10th harmonic of the highest fundamental frequency or to 40 GHz, whichever is lower). For radiated measurement, pre-scanned in three orthogonal panels, X, Y, Z. The worst cases (Z plane) were recorded in this report.
- b. AC power line Conducted Emission was tested under maximum output power.

2.1 Carrier Frequency and Channel

Frequency Band	Channel	Freq. (MHz)	Channel	Freq. (MHz)
2400-2483.5 MHz	1	2412	7	2442
	2	2417	8	2447
	3	2422	9	2452
	4	2427	10	2457
	5	2432	11	2462
	6	2437		



2.2 Test Mode

Final test modes are considering the modulation and worse data rates as below table.

Modulation	Data Rate
802.11b	1 Mbps
802.11g	6 Mbps
802.11n HT20	MCS0

Test Cases	
AC Conducted Emission	Mode 1 :GSM850 Idle + Bluetooth Link + WLAN Link (2.4G) + USB Cable 2(Charging from Adapter 2) + Earphone 2 + Battery 2 for Sample 1
Remark: For Radiated Test Cases, The tests were performed with Adapter 1, Battery 2, Earphone 1 and USB Cable 1.	

2.3 Connection Diagram of Test System

For Radiation

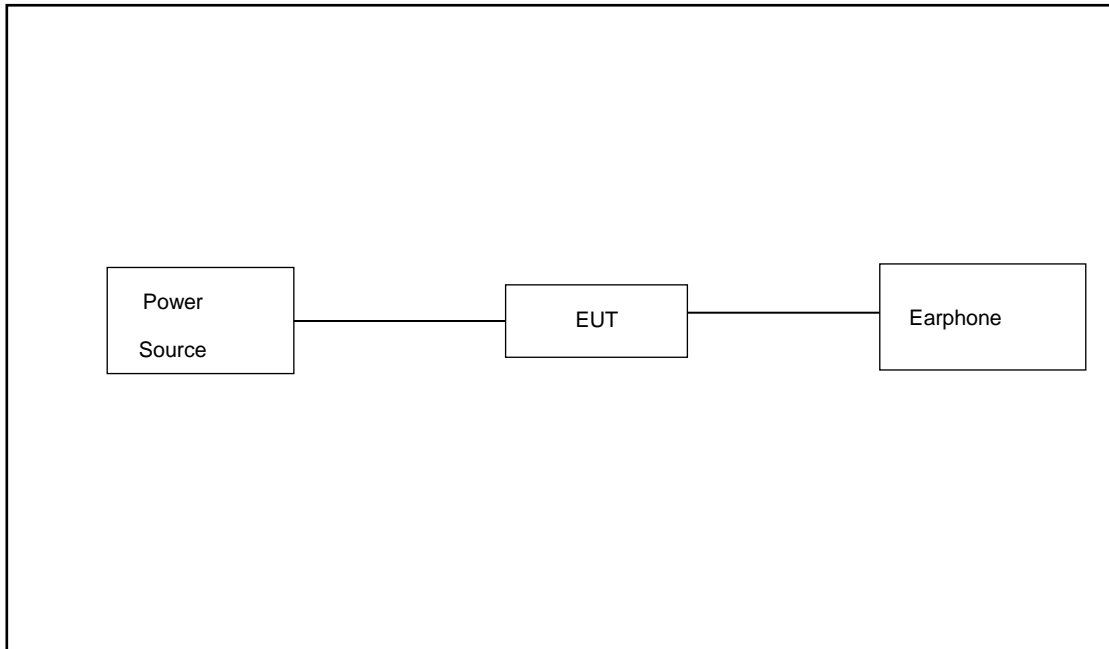

For Conducted Emission

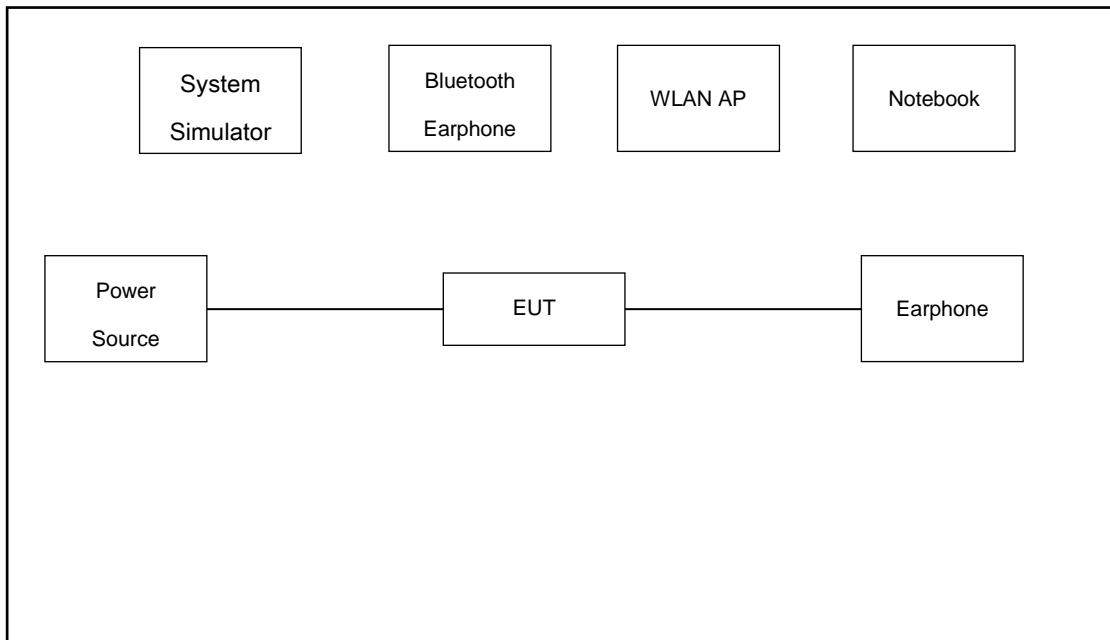

2.4 Support Unit used in test configuration and system

Item	Equipment	Trade Name	Model Name	FCC ID	Data Cable	Power Cord
1.	System Simulator	R&S	CMU 200	N/A	N/A	Unshielded, 1.8 m
2.	WLAN AP	ASUS	RT-AC66U	MSQ-RTAC66U	N/A	Unshielded, 1.8m
3.	Notebook	Dell	Latitude 3400	FCC DoC	N/A	AC I/P: Unshielded, 1.2 m DC O/P: Shielded, 1.8 m
4.	Bluetooth Earphone	Sony Ericsson	MW600	PY700A2029	N/A	N/A

2.5 EUT Operation Test Setup

For Bluetooth function, the engineering test program was provided and enabled to make EUT continuous transmit/receive.

For AC power line conducted emissions, the EUT was set to connect with the WLAN AP under large package sizes transmission.

2.6 Measurement Results Explanation Example

For all conducted test items:

The offset level is set in the spectrum analyzer to compensate the RF cable loss between EUT conducted output port and spectrum analyzer. With the offset compensation, the spectrum analyzer reading level is exactly the EUT RF output level.

Example:

The spectrum analyzer offset is derived from RF cable loss.

Offset = RF cable loss.

Following shows an offset computation example with cable loss 5.0 dB.

$$\begin{aligned} \text{Offset(dB)} &= \text{RF cable loss(dB)} . \\ &= 5.0 \text{ (dB)} \end{aligned}$$

3 Test Result

3.1 6dB Bandwidth Measurement

3.1.1 Limit of 6dB Bandwidth

The minimum 6 dB bandwidth shall be at least 500 kHz.

3.1.2 Measuring Instruments

The measuring equipment is listed in the section 4 of this test report.

3.1.3 Test Procedures

1. The testing follows ANSI C63.10-2013 clause 11.8
2. The RF output of EUT was connected to the spectrum analyzer by RF cable and attenuator. The path loss was compensated to the results for each measurement.
3. Set to the maximum power setting and enable the EUT transmit continuously.
4. Make the measurement with the spectrum analyzer's resolution bandwidth (RBW) = 100 kHz. Set the Video bandwidth (VBW) = 300 kHz. In order to make an accurate measurement. The 6 dB bandwidth must be greater than 500 kHz.
5. For 99% Bandwidth Measurement, the spectrum analyzer's resolution bandwidth (RBW) = 1MHz and set the Video bandwidth (VBW) = 3MHz.
6. Measure and record the results in the test report.

3.1.4 Test Setup

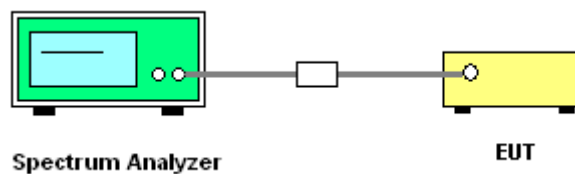



3.1.5 Test Result of 6dB Bandwidth

Please refer to Appendix A.

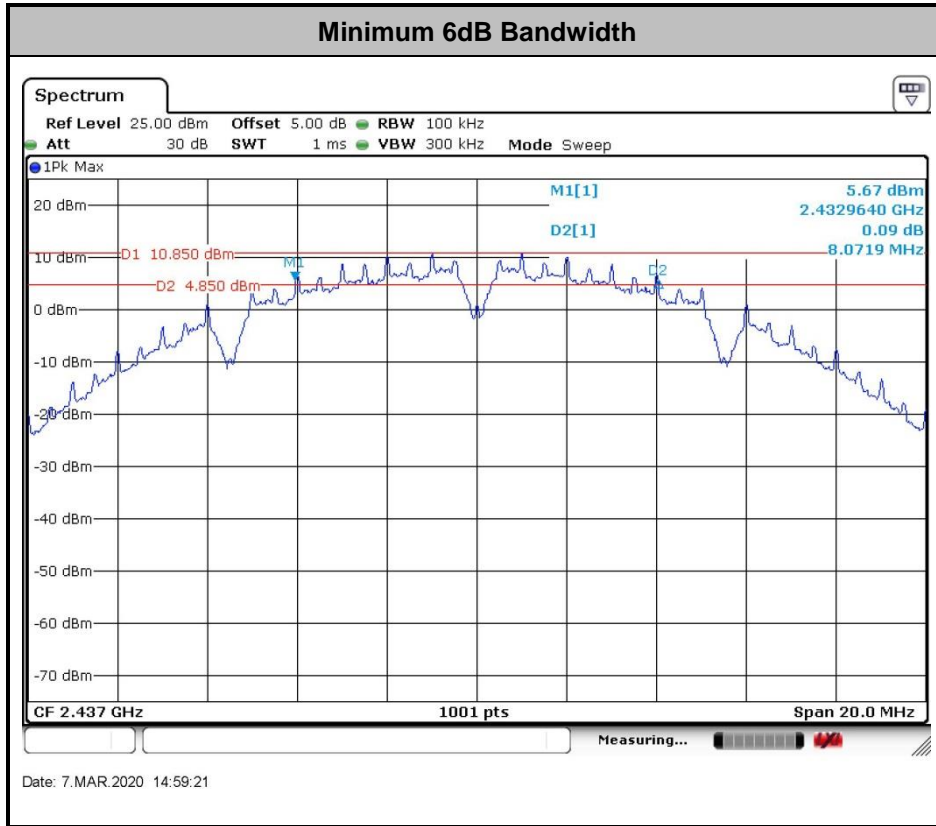

3.2 Output Power Measurement

3.2.1 Limit of Output Power

For systems using digital modulation in the 2400-2483.5MHz, the limit for peak output power is 30dBm. If transmitting antenna with directional gain greater than 6dBi is used, the peak output power from the intentional radiator shall be reduced below the above stated value by the amount in dB that the directional gain of the antenna exceeds 6 dBi. In case of point-to-point operation, the limit has to be reduced by 1dB for every 3dB that the directional gain of the antenna exceeds 6dBi.

3.2.2 Measuring Instruments

The measuring equipment is listed in the section 4 of this test report.

3.2.3 Test Procedures

1. The testing follows the Measurement Procedure of ANSI C63.10-2013 clause 11.9.1.3 PKPM1 Peak power meter or ANSI C63.10-2013 clause 11.9.2.3.2 Method AVGPM-G method.
2. The RF output of EUT was connected to the power meter by RF cable and attenuator. The path loss was compensated to the results for each measurement.
3. Set to the maximum power setting and enable the EUT transmit continuously.
4. Measure the conducted output power and record the results in the test report.

3.2.4 Test Setup

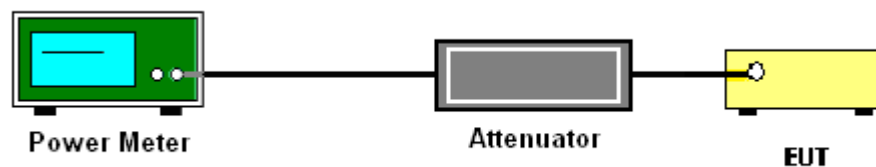

3.2.5 Test Result of Peak Output Power

Please refer to Appendix A.

3.2.6 Test Result of Average output Power (Reporting Only)

Please refer to Appendix A.



3.3 Power Spectral Density Measurement

3.3.1 Limit of Power Spectral Density

The peak power spectral density shall not be greater than 8dBm in any 3kHz band at any time interval of continuous transmission.

3.3.2 Measuring Instruments

The measuring equipment is listed in the section 4 of this test report.

3.3.3 Test Procedures

1. The testing follows Measurement Procedure of ANSI C63.10-2013 clause 11.10.2 Method PKPSD.
2. The RF output of EUT was connected to the spectrum analyzer by RF cable and attenuator. The path loss was compensated to the results for each measurement.
3. Set to the maximum power setting and enable the EUT transmit continuously.
4. Make the measurement with the spectrum analyzer's resolution bandwidth (RBW) = 3 kHz. Video bandwidth VBW = 10 kHz In order to make an accurate measurement, set the span to 1.5 times DTS Channel Bandwidth. (6dB BW)
5. Detector = peak, Sweep time = auto couple, Trace mode = max hold, Allow trace to fully stabilize. Use the peak marker function to determine the maximum power level.
6. Measure and record the results in the test report.

3.3.4 Test Setup

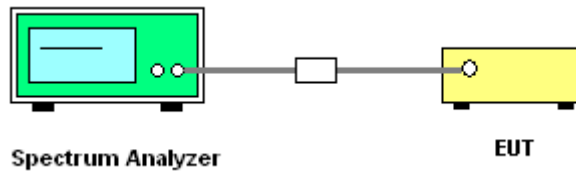

3.3.5 Test Result of Power Spectral Density

Please refer to Appendix A.

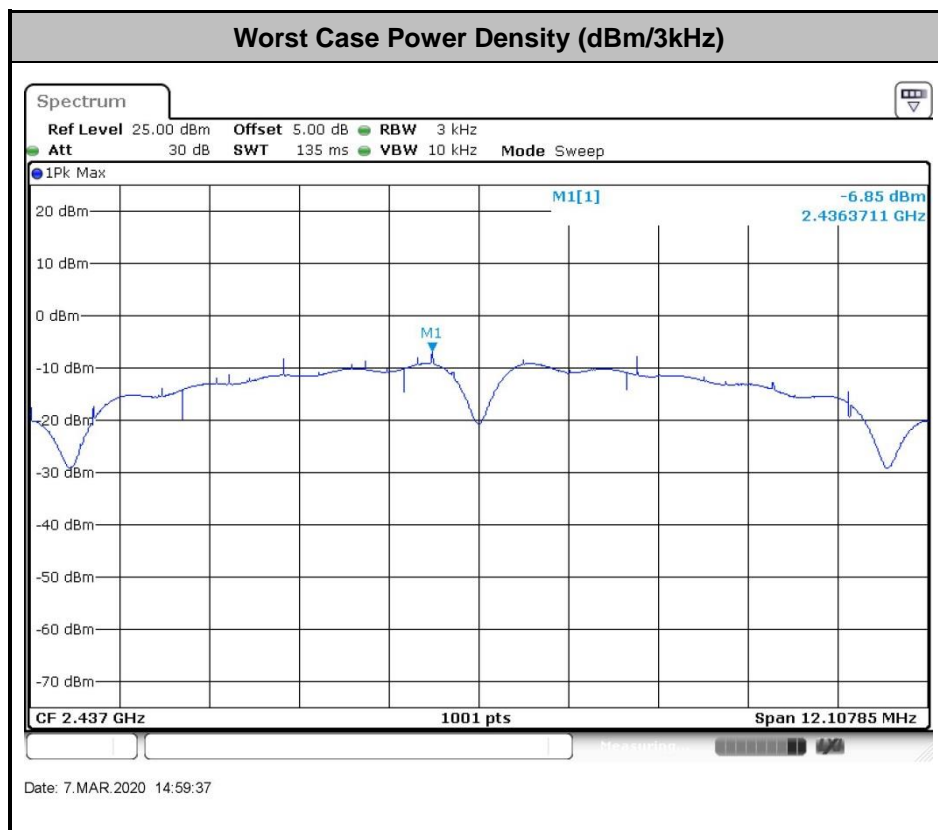

3.4 Conducted Band Edges and Spurious Emission Measurement

3.4.1 Limit of Conducted Band Edges and Spurious Emission Measurement

In any 100 kHz bandwidth outside of the authorized frequency band, the emissions which fall in the non-restricted bands shall be attenuated at least 20 dB / 30dB relative to the maximum PSD level in 100 kHz by RF conducted measurement.

3.4.2 Measuring Instruments

The measuring equipment is listed in the section 4 of this test report.

3.4.3 Test Procedures

1. The testing follows ANSI C63.10-2013 clause 11.13
2. The RF output of EUT was connected to the spectrum analyzer by RF cable and attenuator. The path loss was compensated to the results for each measurement.
3. Set to the maximum power setting and enable the EUT transmit continuously.
4. Set RBW = 100 kHz, VBW=300 kHz, Peak Detector. Unwanted Emissions measured in any 100 kHz bandwidth outside of the authorized frequency band shall be attenuated by at least 20 dB relative to the maximum in-band peak PSD level in 100 kHz when maximum peak conducted output power procedure is used. If the transmitter complies with the conducted power limits based on the use of RMS averaging over a time interval, the attenuation required under this paragraph shall be 30 dB instead of 20 dB per 15.247(d).
5. Measure and record the results in the test report.
6. The RF fundamental frequency should be excluded against the limit line in the operating frequency band.

3.4.4 Test Setup

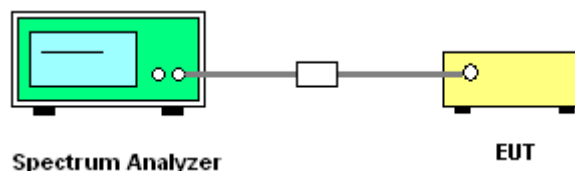



3.4.5 Test Result of Conducted Band Edges and Spurious Emission

Test Mode :	802.11b	Test Channel :	01
-------------	---------	----------------	----

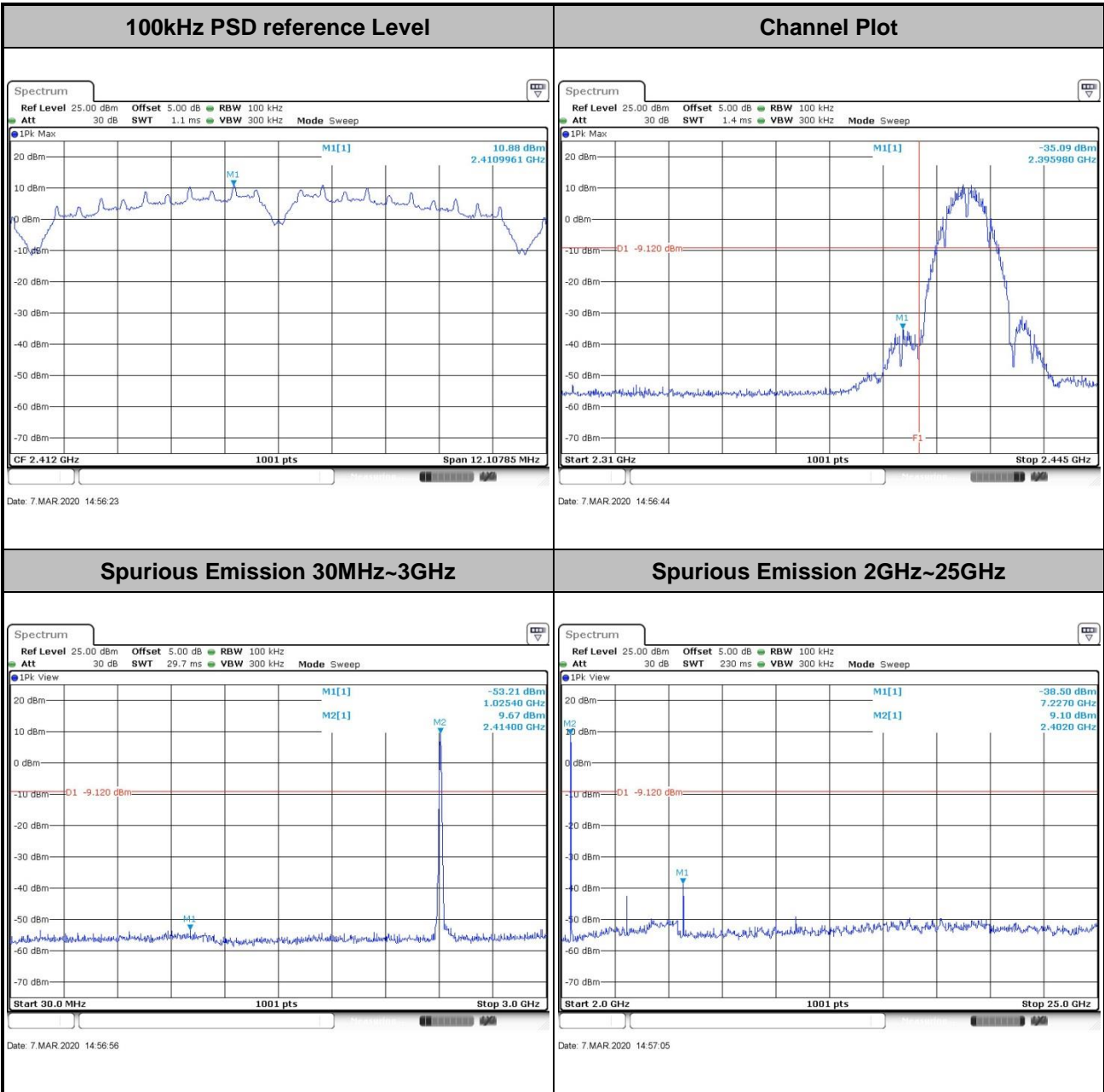



Test Mode :	802.11b	Test Channel :	06
-------------	---------	----------------	----

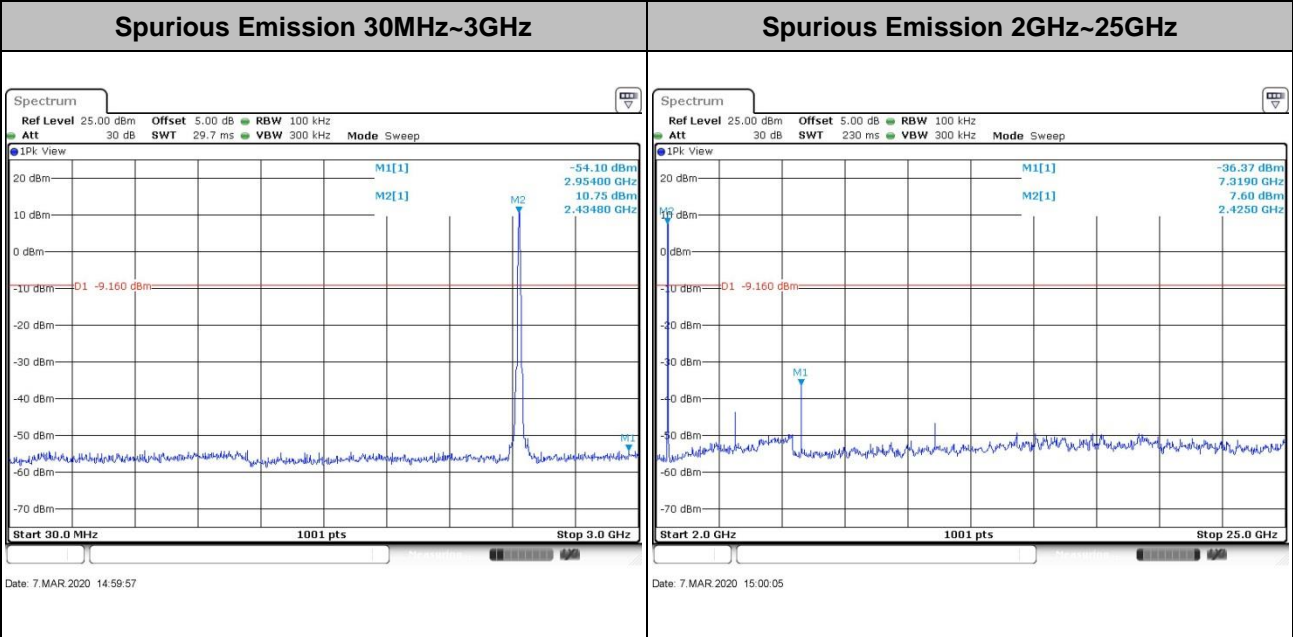
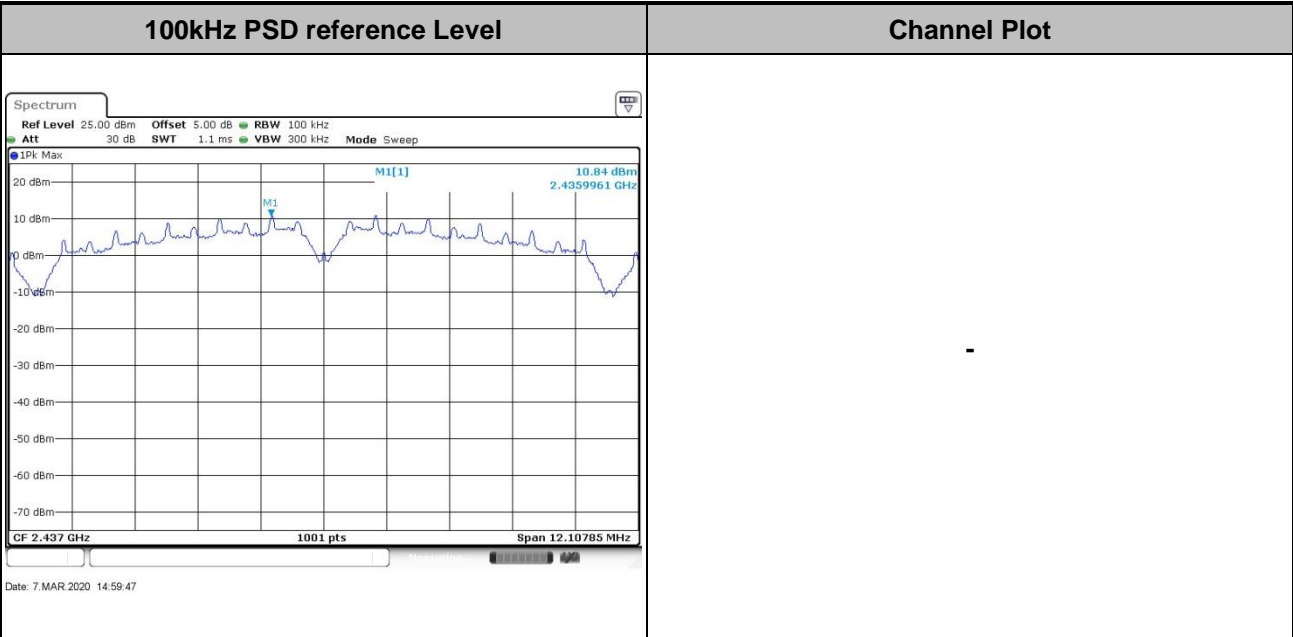



Test Mode :	802.11b	Test Channel :	11
-------------	---------	----------------	----

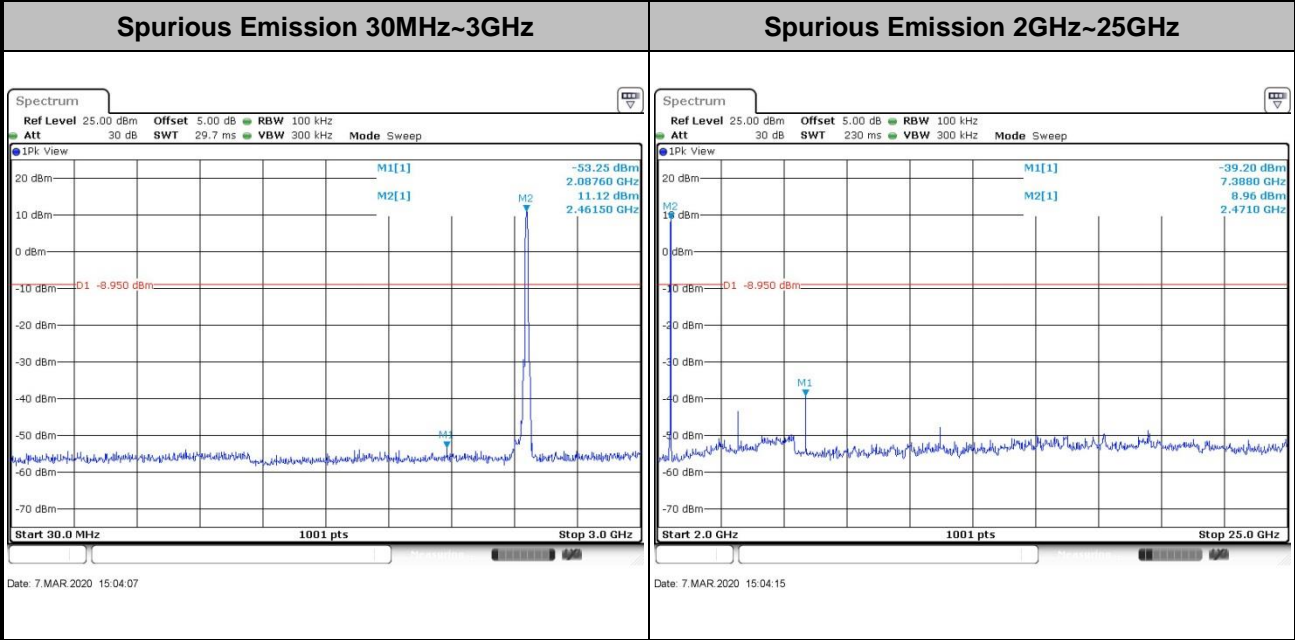
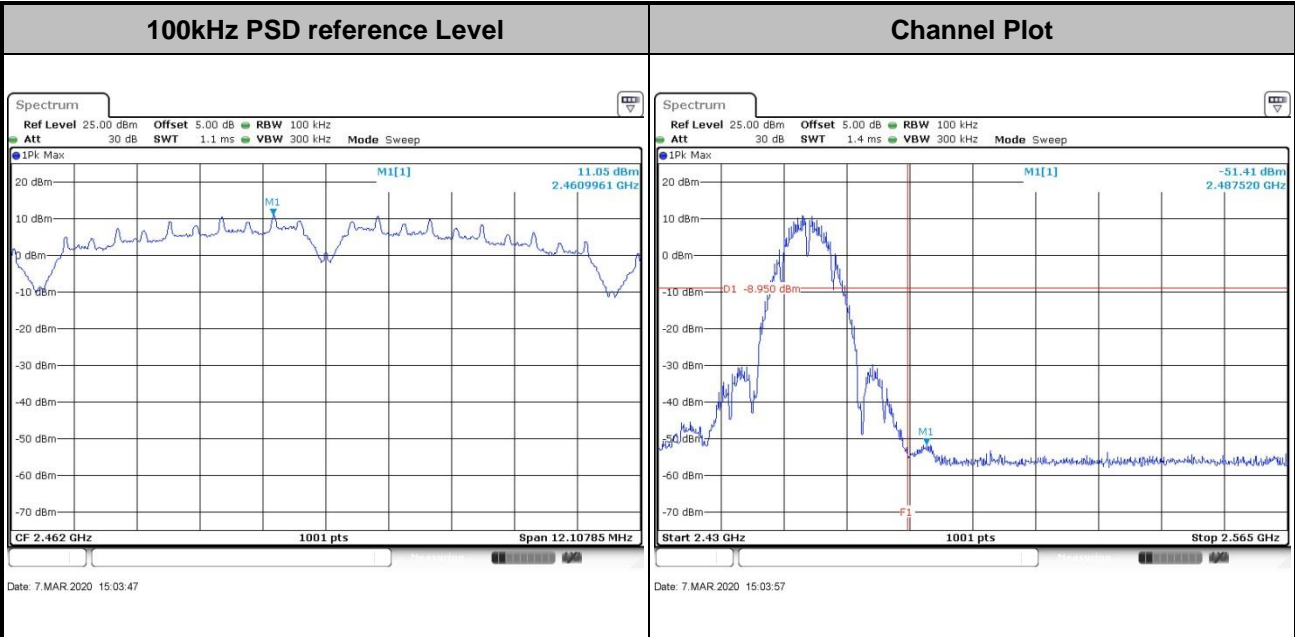



Test Mode : 802.11g Test Channel : 01

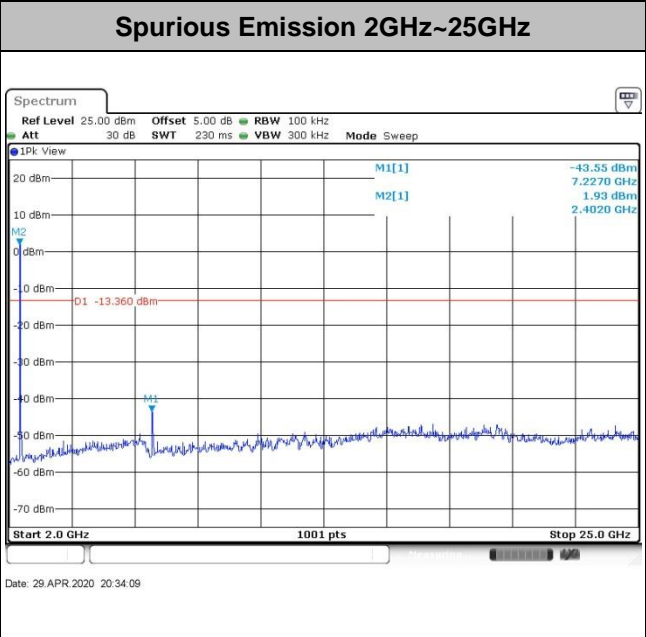
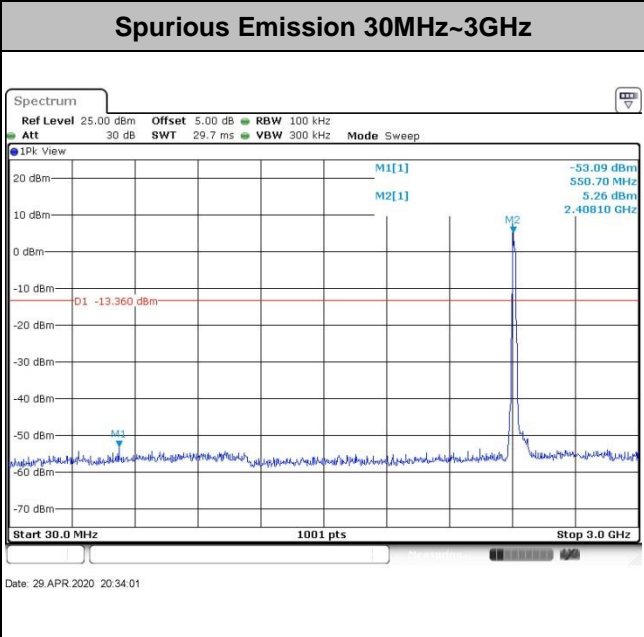
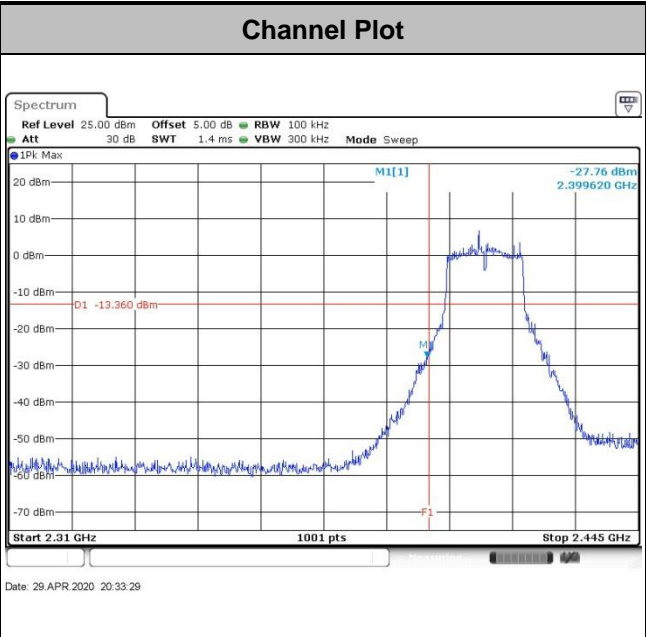
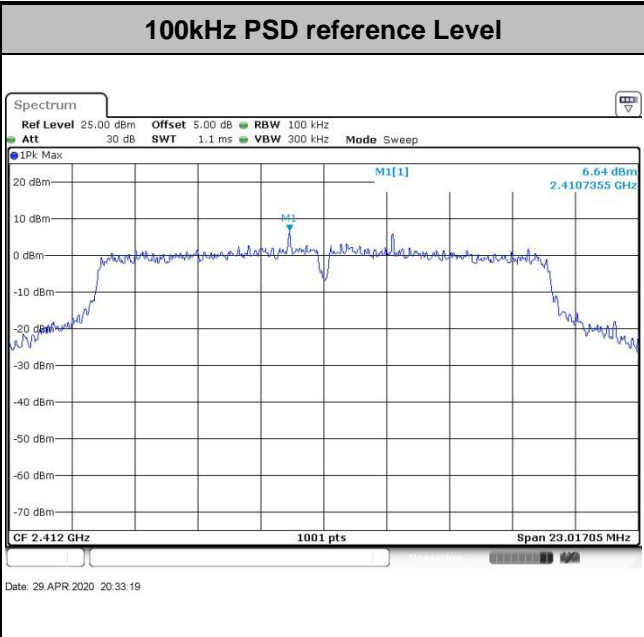



Test Mode :	802.11g	Test Channel :	06
-------------	---------	----------------	----

100kHz PSD reference Level	Channel Plot
-----------------------------------	---------------------

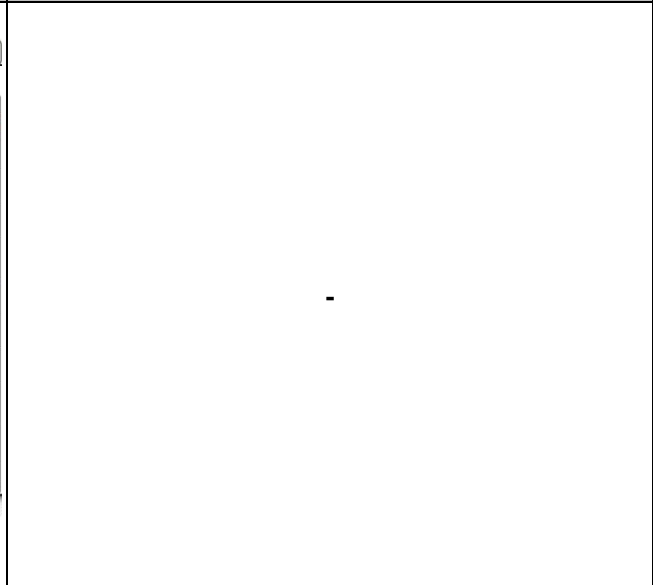
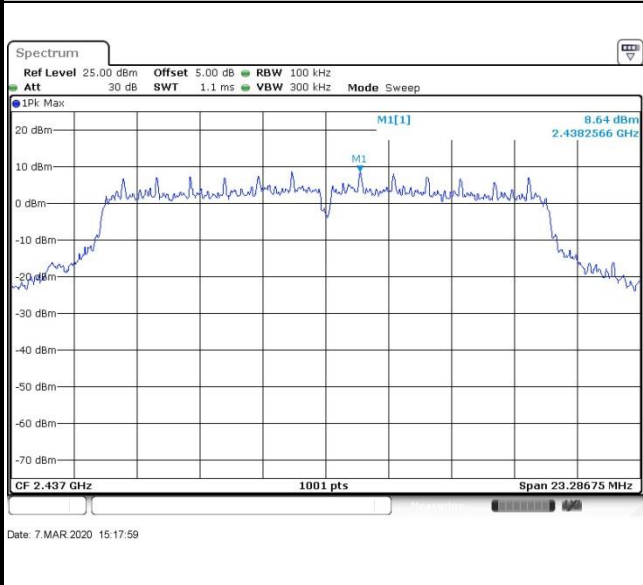

Spurious Emission 30MHz~3GHz	Spurious Emission 2GHz~25GHz
-------------------------------------	-------------------------------------

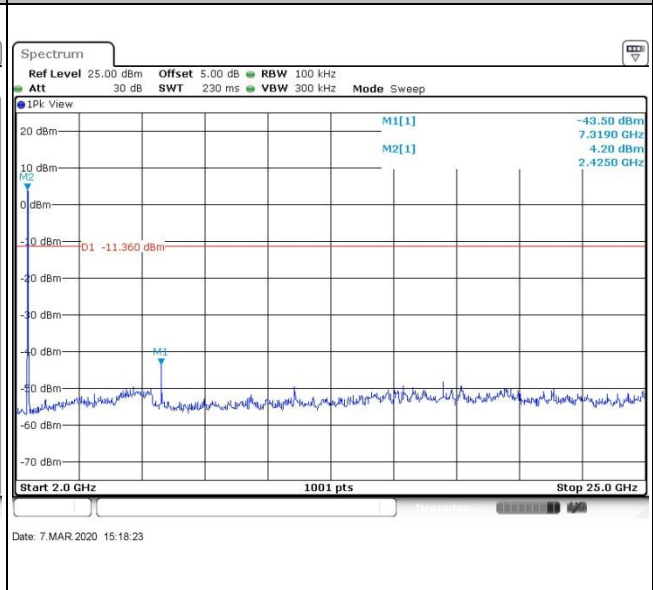
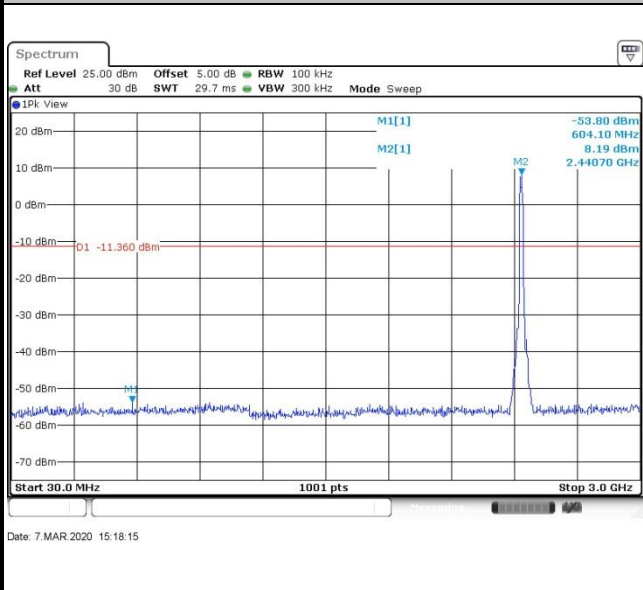



Test Mode :	802.11g	Test Channel :	11
-------------	---------	----------------	----

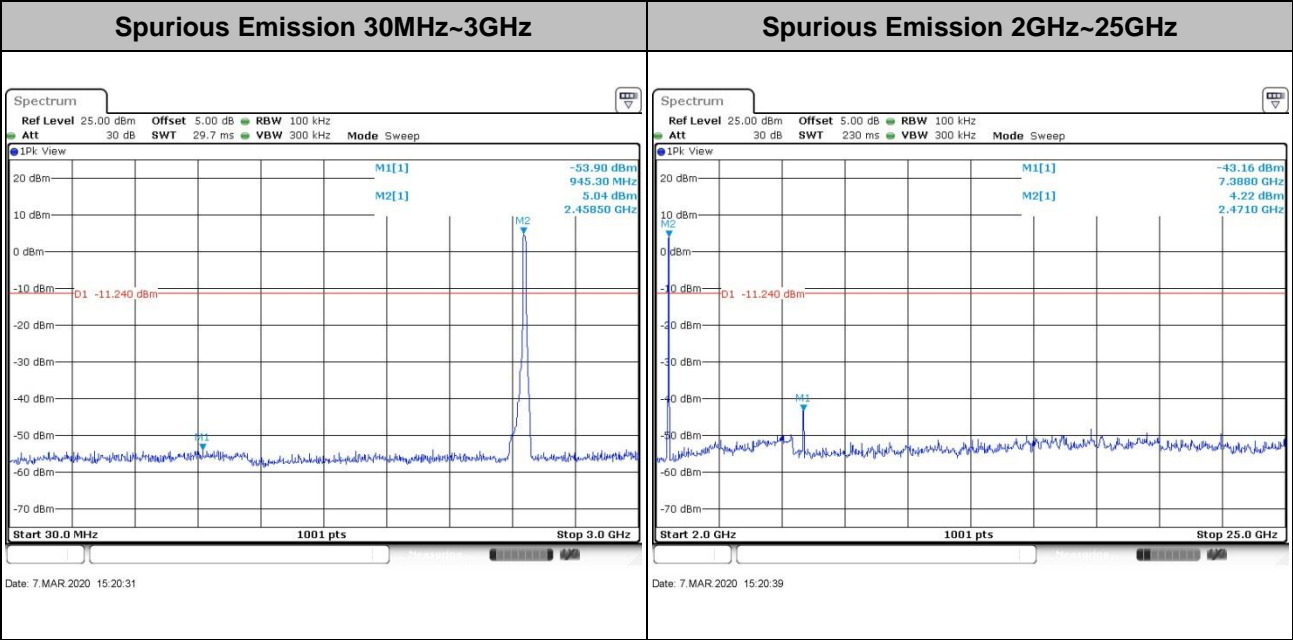
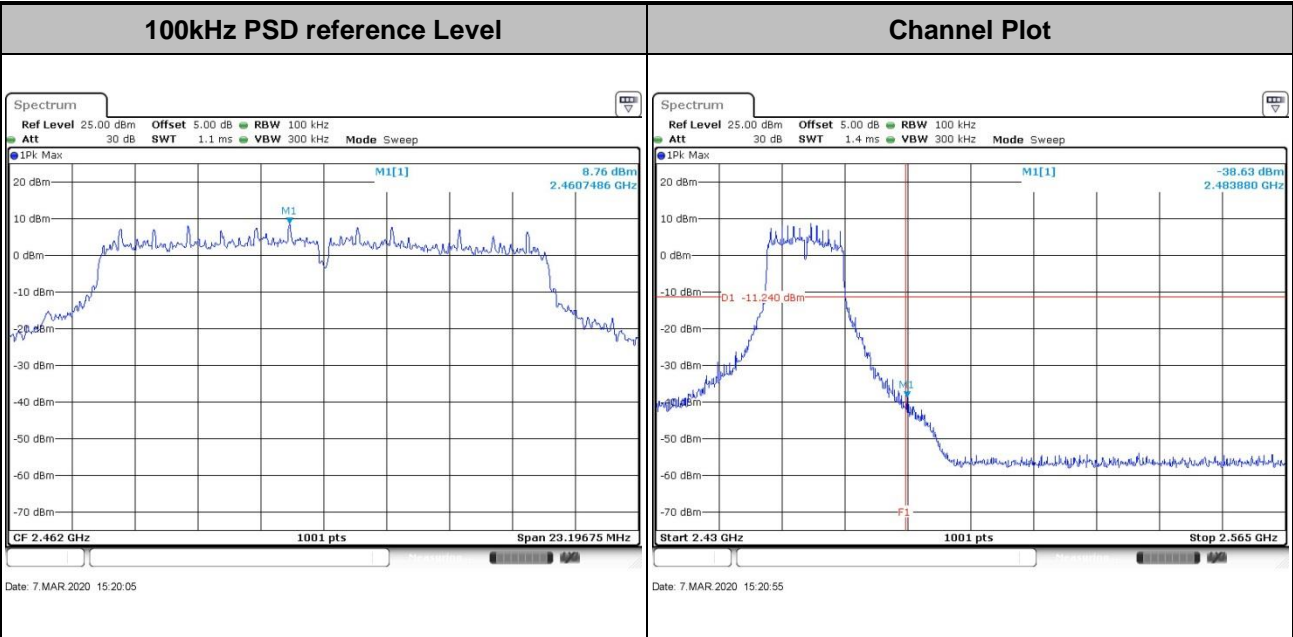



Test Mode :	802.11n HT20	Test Channel :	01
-------------	--------------	----------------	----

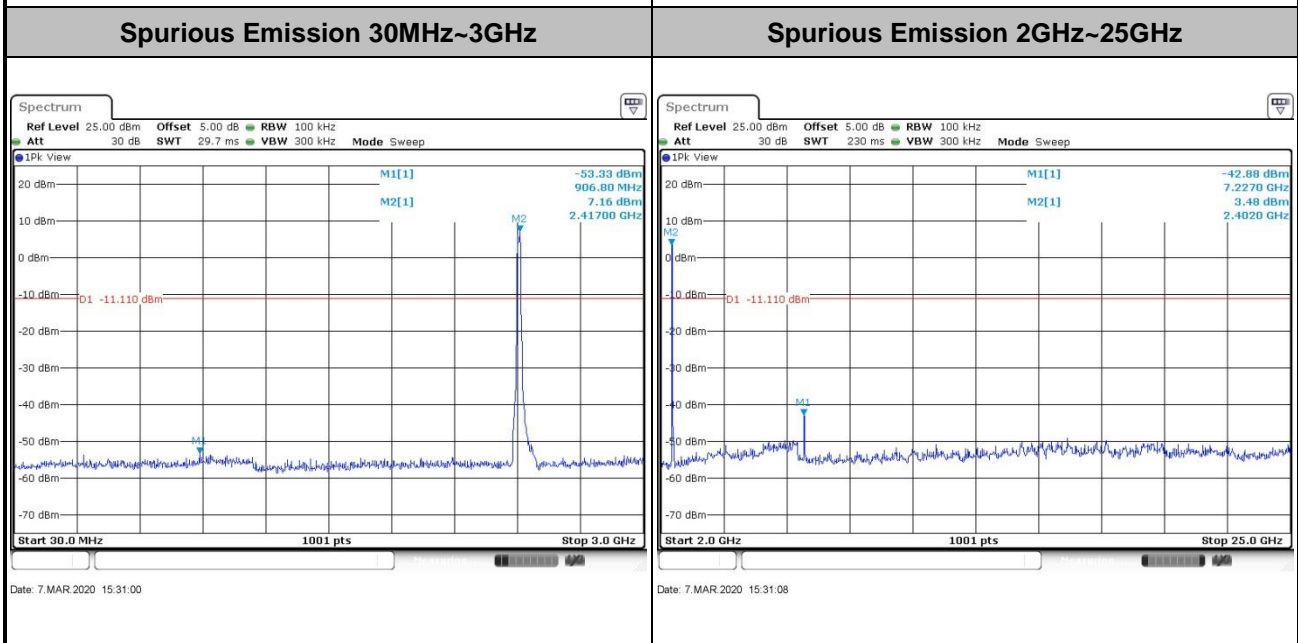
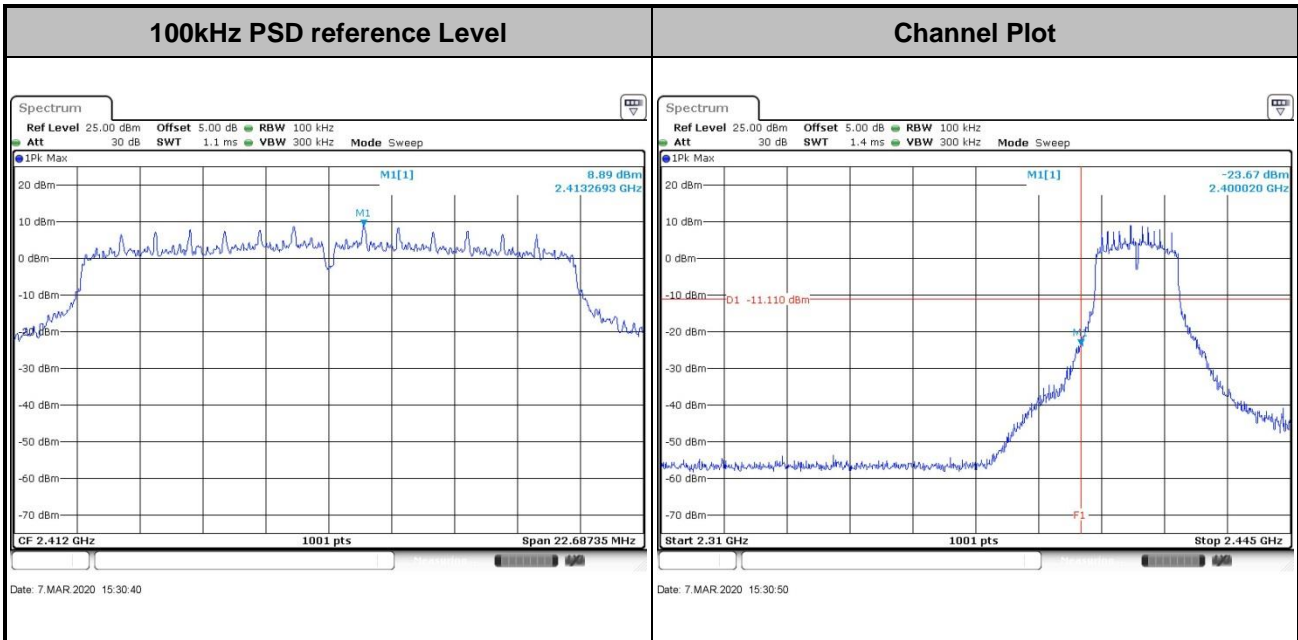



Test Mode : 802.11n HT20 Test Channel : 06

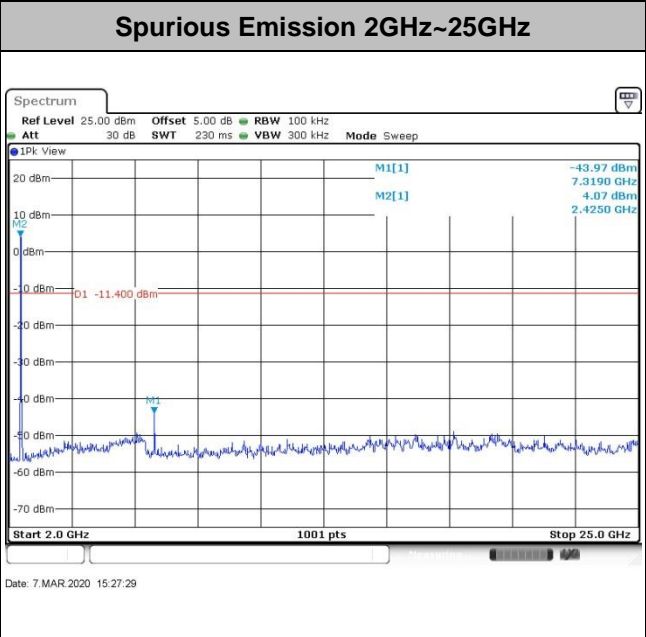
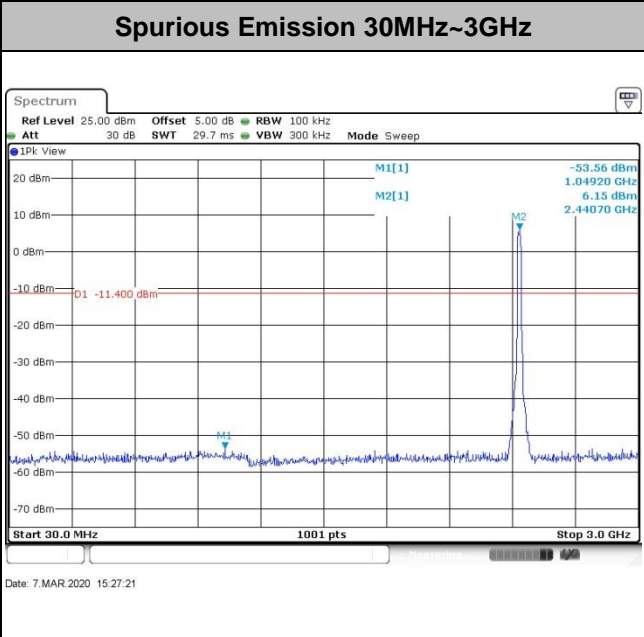
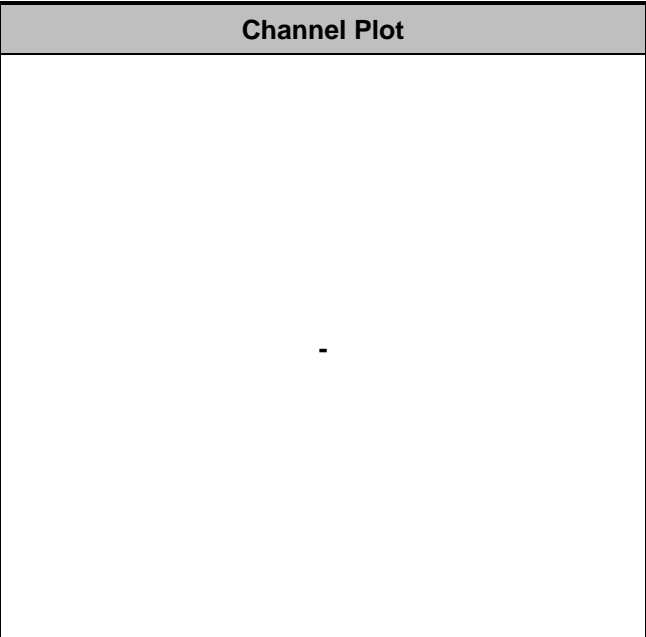
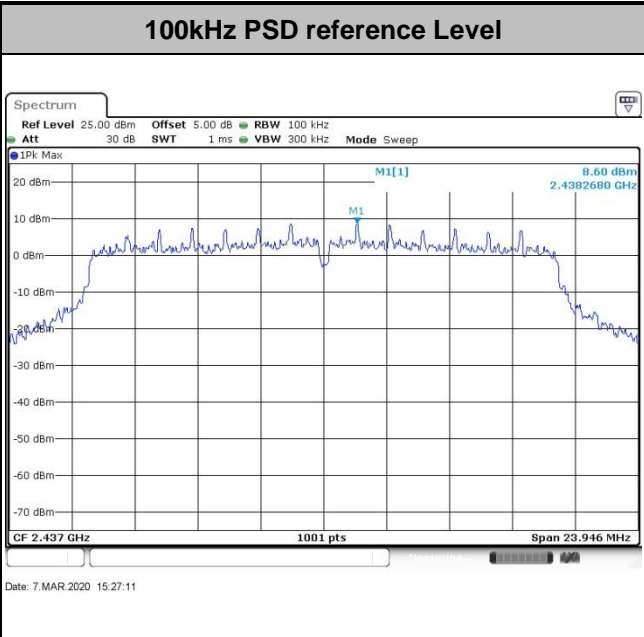



Test Mode :	802.11n HT20	Test Channel :	11
-------------	--------------	----------------	----

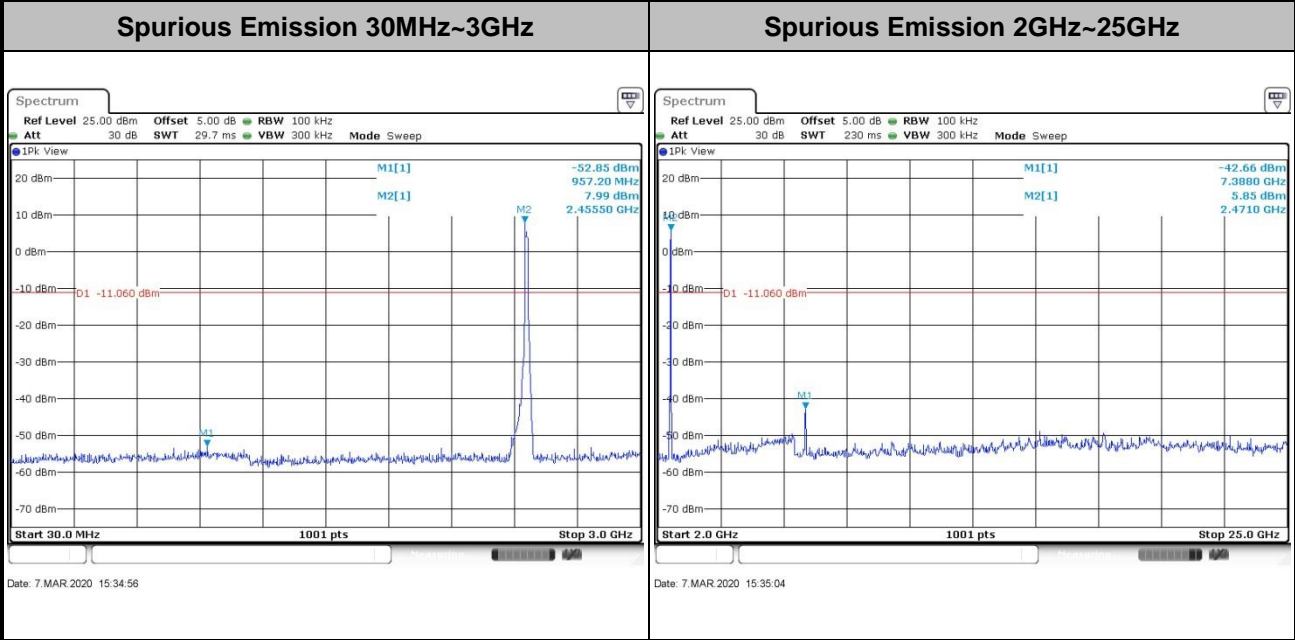
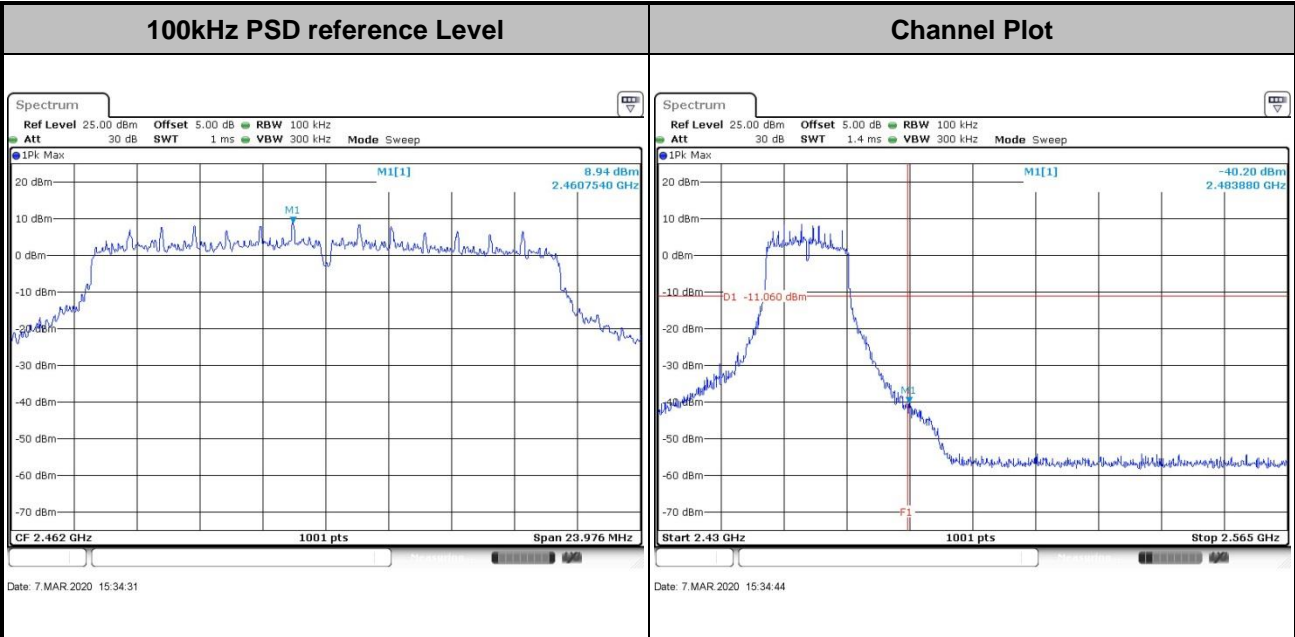



3.5 Radiated Band Edges and Spurious Emission Measurement

3.5.1 Limit of Radiated band edge and Spurious Emission Measurement

In any 100 kHz bandwidth outside the intentional radiator frequency band, all harmonics/spurious must be at least 20 dB below the highest emission level within the authorized band. If the output power of this device was measured by spectrum analyzer, the attenuation under this paragraph shall be 30 dB instead of 20 dB. In addition, radiated emissions which fall in the restricted bands must also comply with the limits as below.

Frequency (MHz)	Field Strength (microvolts/meter)	Measurement Distance (meters)
0.009 – 0.490	2400/F(kHz)	300
0.490 – 1.705	24000/F(kHz)	30
1.705 – 30.0	30	30
30 – 88	100	3
88 – 216	150	3
216 - 960	200	3
Above 960	500	3

3.5.2 Measuring Instruments

The measuring equipment is listed in the section 4 of this test report.



3.5.3 Test Procedures

1. The testing follows ANSI C63.10-2013 clause 11.11 & 11.12
2. The EUT was arranged to its worst case and then tune the antenna tower (from 1 m to 4 m) and turntable (from 0 degree to 360 degrees) to find the maximum reading. A pre-amp and a high pass filter are used for the test in order to get better signal level.
3. The EUT was placed on a turntable with 0.8 meter for frequency below 1GHz and 1.5 meter for frequency above 1GHz respectively above ground.
4. The EUT was set 3 meters from the interference receiving antenna, which was mounted on the top of a variable height antenna tower.
5. Corrected Reading: Antenna Factor + Cable Loss + Read Level - Preamp Factor = Level
6. For testing below 1GHz, if the emission level of the EUT in peak mode was 3 dB lower than the limit specified, then peak values of EUT will be reported, otherwise, the emissions will be repeated one by one using the CISPR quasi-peak method and reported.
7. For testing above 1GHz, the emission level of the EUT in peak mode was 20dB lower than average limit (that means the emission level in average mode also complies with the limit in average mode), then peak values of EUT will be reported, otherwise, the emissions will be measured in average mode again and reported.
8. Use the following spectrum analyzer settings:
 - (1) Span shall wide enough to fully capture the emission being measured;
 - (2) Set RBW=100 kHz for $f < 1$ GHz; VBW \geq RBW; Sweep = auto; Detector function = peak; Trace = max hold;
 - (3) Set RBW = 1 MHz, VBW= 3MHz for $f \geq 1$ GHz for peak measurement.
For average measurement:
 - VBW = 10 Hz, when duty cycle is no less than 98 percent.
 - VBW $\geq 1/T$, when duty cycle is less than 98 percent where T is the minimum transmission duration over which the transmitter is on and is transmitting at its maximum power control level for the tested mode of operation.

3.5.4 Test Setup

For radiated emissions below 30MHz

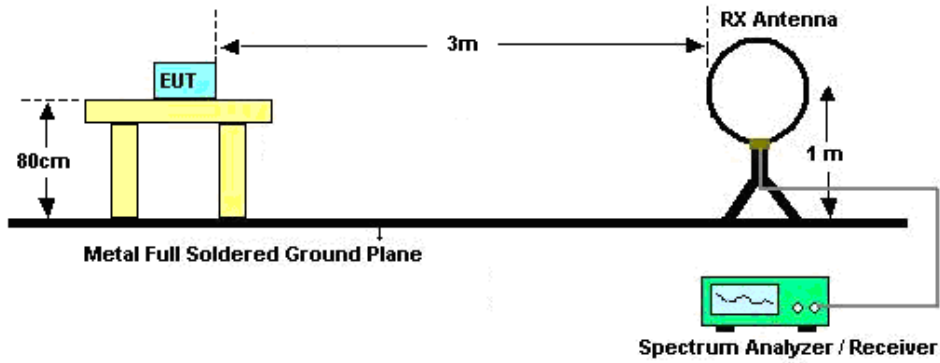

For radiated emissions from 30MHz to 1GHz

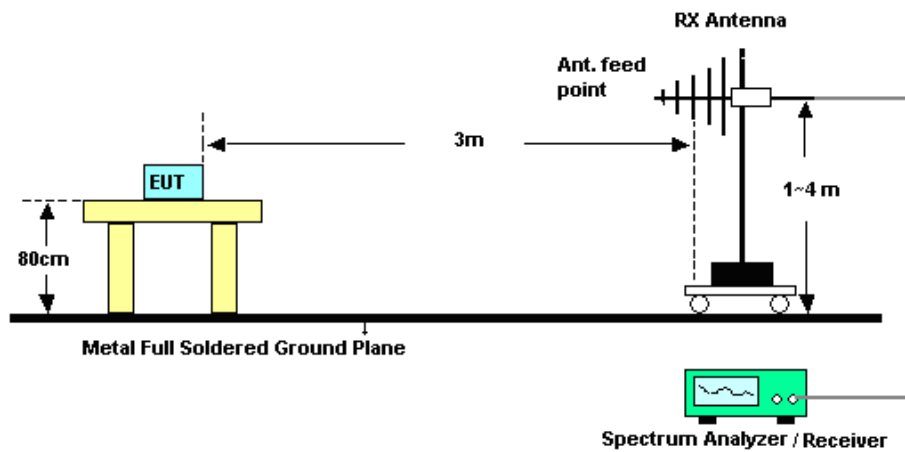

For radiated emissions above 1GHz

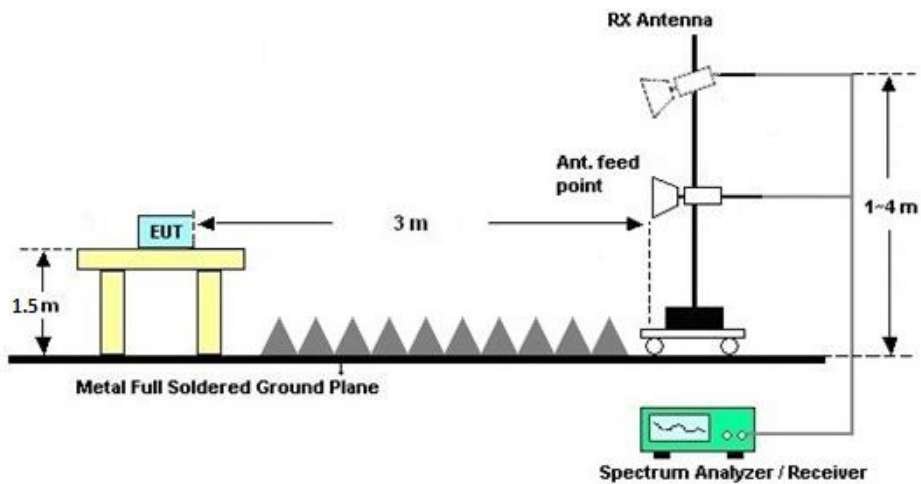



3.5.5 Test Results of Radiated Spurious Emissions (9kHz ~ 30MHz)

The low frequency, which started from 9 kHz to 30MHz, was pre-scanned and the result which was 20dB lower than the limit line was not reported.

There is a comparison data of both open-field test site and semi-Anechoic chamber, and the result came out very similar.

3.5.6 Test Result of Radiated Spurious at Band Edges

Please refer to Appendix C.

3.5.7 Duty Cycle

Please refer to Appendix D.

3.5.8 Test Result of Radiated Spurious Emission (30MHz ~ 10th Harmonic)

Please refer to Appendix C.

3.6 AC Conducted Emission Measurement

3.6.1 Limit of AC Conducted Emission

For equipment that is designed to be connected to the public utility (AC) power line, the radio frequency voltage that is conducted back onto the AC power line on any frequency or frequencies within the band 150 kHz to 30 MHz shall not exceed the limits in the following table.

Frequency of Emission (MHz)	Conducted Limit (dB μ V)	
	Quasi-Peak	Average
0.15-0.5	66 to 56*	56 to 46*
0.5-5	56	46
5-30	60	50

*Decreases with the logarithm of the frequency.

3.6.2 Measuring Instruments

The measuring equipment is listed in the section 4 of this test report.

3.6.3 Test Procedures

1. The EUT was placed 0.4 meter from the conducting wall of the shielding room, and it was kept at least 80 centimeters from any other grounded conducting surface.
2. Connect EUT to the power mains through a line impedance stabilization network (LISN).
3. All the support units are connecting to the other LISN.
4. The LISN provides 50 ohm coupling impedance for the measuring instrument.
5. The FCC states that a 50 ohm, 50 microhenry LISN should be used.
6. Both sides of AC line were checked for maximum conducted interference.
7. The frequency range from 150 kHz to 30 MHz was searched.
8. Set the test-receiver system to Peak Detect Function and specified bandwidth (IF bandwidth = 9kHz) with Maximum Hold Mode.

3.6.4 Test Setup

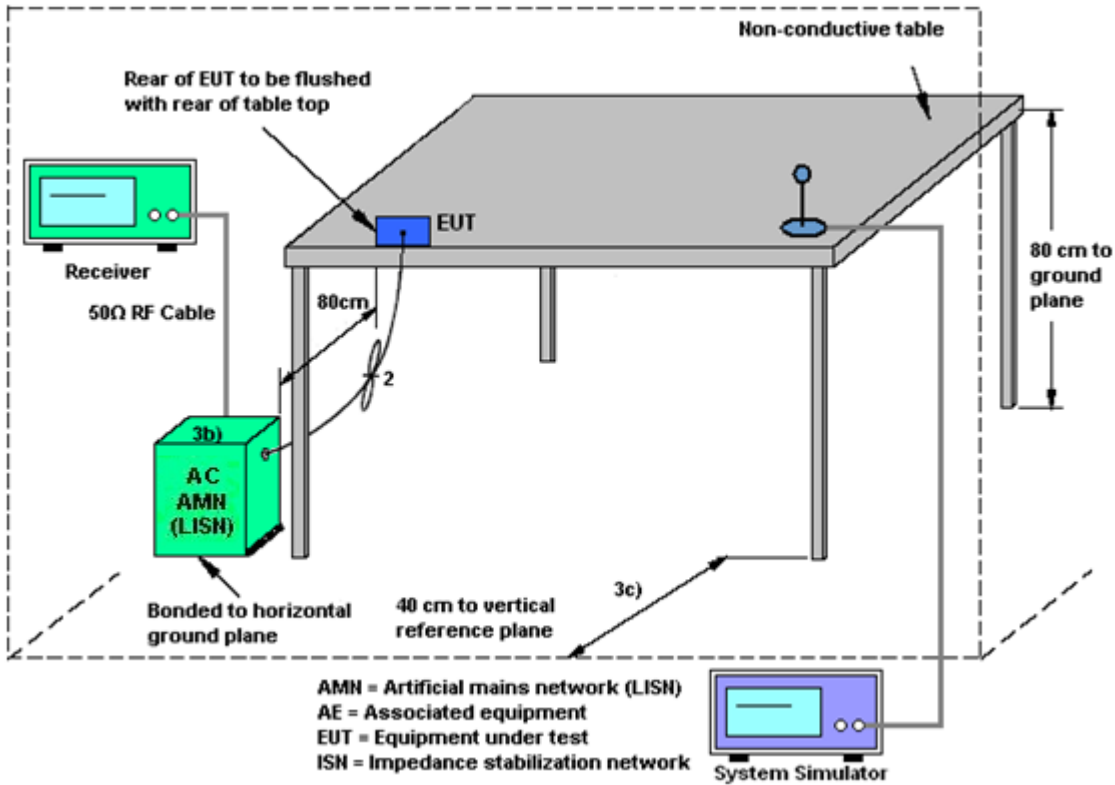

3.6.5 Test Result of AC Conducted Emission

Please refer to Appendix B.



3.7 Antenna Requirements

3.7.1 Standard Applicable

If directional gain of transmitting Antennas is greater than 6dBi, the power shall be reduced by the same level in dB comparing to gain minus 6dBi. The use of a permanently attached Antenna or of an Antenna that uses a unique coupling to the intentional radiator shall be considered sufficient to comply with the rule.

3.7.2 Antenna Anti-Replacement Construction

An embedded-in antenna design is used.

3.7.3 Antenna Gain

The antenna peak gain of EUT is less than 6 dBi. Therefore, it is not necessary to reduce maximum peak output power limit.



4 List of Measuring Equipment

Instrument	Manufacturer	Model No.	Serial No.	Characteristics	Calibration Date	Test Date	Due Date	Remark
Spectrum Analyzer	R&S	FSV40	101040	10Hz~40GHz	Nov. 02, 2019	Mar. 07, 2020~ Apr. 29, 2020	Nov. 01, 2020	Conducted (TH01-KS)
Pulse Power Sensor	Anritsu	MA2411B	0917070	300MHz~40GHz	Jan. 08, 2020	Mar. 07, 2020~ Apr. 29, 2020	Jan. 07, 2021	Conducted (TH01-KS)
Power Meter	Anritsu	ML2495A	1005002	50MHz Bandwidth	Jan. 08, 2020	Mar. 07, 2020~ Apr. 29, 2020	Jan. 07, 2021	Conducted (TH01-KS)
EMI Test Receiver	Keysight	N9038A	MY57290157	3Hz~8.5GHz;Max 30dBm	Jul. 18, 2019	Apr. 29, 2020	Jul. 17, 2020	Radiation (03CH06-KS)
EXA Spectrum Analyzer	Keysight	N9010A	MY55150208	10Hz-44GHz	Apr. 15, 2020	Apr. 29, 2020	Apr. 14, 2021	Radiation (03CH06-KS)
Loop Antenna	R&S	HFH2-Z2	100321	9kHz~30MHz	Nov. 10, 2019	Apr. 29, 2020	Nov. 09, 2020	Radiation (03CH06-KS)
Bilog Antenna	TeseQ	CBL6111D	49921	30MHz-1GHz	May 30, 2019	Apr. 29, 2020	May 29, 2020	Radiation (03CH06-KS)
Double Ridge Horn Antenna	ETS-Lindgren	3117	75959	1GHz~18GHz	Apr. 26, 2020	Apr. 29, 2020	Apr. 25, 2021	Radiation (03CH06-KS)
SHF-EHF Horn	Com-power	AH-840	101070	18GHz~40GHz	Jan. 08, 2020	Apr. 29, 2020	Jan. 07, 2021	Radiation (03CH06-KS)
Amplifier	SONOMA	310N	187289	9KHz ~1GHZ	Aug. 06, 2019	Apr. 29, 2020	Aug. 05, 2020	Radiation (03CH06-KS)
Amplifier	MITEQ	TTA1840-35-HG	2014749	18~40GHz	Jun. 05, 2019	Apr. 29, 2020	Jun. 04, 2020	Radiation (03CH06-KS)
high gain Amplifier	MITEQ	AMF-7D-0010 1800-30-10P	2025788	1Ghz-18Ghz	Aug. 16, 2019	Apr. 29, 2020	Aug. 15, 2020	Radiation (03CH06-KS)
Amplifier	Keysight	83017A	MY53270203	500MHz~26.5GHz	Apr. 14, 2020	Apr. 29, 2020	Apr. 13, 2021	Radiation (03CH06-KS)
AC Power Source	Chroma	61601	F104090004	N/A	NCR	Apr. 29, 2020	NCR	Radiation (03CH06-KS)
Turn Table	ChamPro	EM 1000-T	060762-T	0~360 degree	NCR	Apr. 29, 2020	NCR	Radiation (03CH06-KS)
Antenna Mast	ChamPro	EM 1000-A	060762-A	1 m~4 m	NCR	Apr. 29, 2020	NCR	Radiation (03CH06-KS)
AC Power Source	ChainTek	APC-1000W	N/A	N/A	NCR	Apr. 21, 2020	NCR	Conduction (CO05-HY)
EMI Test Receiver	Rohde & Schwarz	ESR3	102388	9kHz~3.6GHz	Nov. 15, 2019	Apr. 21, 2020	Nov. 14, 2020	Conduction (CO05-HY)
Hygrometer	Testo	608-H1	34913912	N/A	Nov. 07, 2019	Apr. 21, 2020	Nov. 06, 2020	Conduction (CO05-HY)
LISN	Rohde & Schwarz	ENV216	100081	9kHz~30MHz	Nov. 15, 2019	Apr. 21, 2020	Nov. 14, 2020	Conduction (CO05-HY)
LF Cable	HUBER + SUHNER	RG-214/U	LF01	N/A	Jan. 02, 2020	Apr. 21, 2020	Jan. 01, 2021	Conduction (CO05-HY)
Pulse Limiter	Rohde & Schwarz	ESH3-Z2	100851	N/A	Jan. 02, 2020	Apr. 21, 2020	Jan. 01, 2021	Conduction (CO05-HY)

NCR: No Calibration Required



5 Uncertainty of Evaluation

The measurement uncertainties shown below were calculated in accordance with the requirements of ANSI 63.10-2013. All the measurement uncertainty value were shown with a coverage K=2 to indicate 95% level of confidence. The measurement data show herein meets or exceeds the CISPR measurement uncertainty values specified in CISPR 16-4-2 and can be compared directly to specified limit to determine compliance.

Uncertainty of Conducted Emission Measurement (150kHz ~ 30MHz)

Measuring Uncertainty for a Level of Confidence of 95% (U = 2Uc(y))	2.7dB
---	-------

Uncertainty of Radiated Emission Measurement (30 MHz ~ 1000 MHz)

Measuring Uncertainty for a Level of Confidence of 95% (U = 2Uc(y))	5.0dB
---	-------

Uncertainty of Radiated Emission Measurement (1000 MHz ~ 18000 MHz)

Measuring Uncertainty for a Level of Confidence of 95% (U = 2Uc(y))	5.0dB
---	-------

Uncertainty of Radiated Emission Measurement (18000 MHz ~ 40000 MHz)

Measuring Uncertainty for a Level of Confidence of 95% (U = 2Uc(y))	5.0dB
---	-------



Appendix A. Conducted Test Results

A1 - DTS Part

Test Engineer:	Aaron shen	Temperature:	21~25	°C
Test Date:	2020/03/07~2020/04/29	Relative Humidity:	51~54	%

TEST RESULTS DATA
6dB and 99% Occupied Bandwidth

2.4GHz Band								
Mod.	Data Rate	NTX	CH.	Freq. (MHz)	99% Occupied BW (MHz)	6dB BW (MHz)	6dB BW Limit (MHz)	Pass/Fail
11b	1Mbps	1	1	2412	14.04	8.07	0.50	Pass
11b	1Mbps	1	6	2437	14.14	8.07	0.50	Pass
11b	1Mbps	1	11	2462	14.34	8.07	0.50	Pass
11g	6Mbps	1	1	2412	17.43	15.34	0.50	Pass
11g	6Mbps	1	6	2437	17.48	15.52	0.50	Pass
11g	6Mbps	1	11	2462	17.43	15.46	0.50	Pass
HT20	MCS0	1	1	2412	18.58	15.12	0.50	Pass
HT20	MCS0	1	6	2437	18.68	15.96	0.50	Pass
HT20	MCS0	1	11	2462	18.63	15.98	0.50	Pass

TEST RESULTS DATA
Peak Power Table

2.4GHz Band										
Mod.	Data Rate	NTX	CH.	Freq. (MHz)	Peak Conducted Power (dBm)	Conducted Power Limit (dBm)	DG (dBi)	EIRP Power (dBm)	EIRP Power Limit (dBm)	Pass /Fail
11b	1Mbps	1	1	2412	20.13	30.00	-2.50	17.63	36.00	Pass
11b	1Mbps	1	6	2437	20.02	30.00	-2.50	17.52	36.00	Pass
11b	1Mbps	1	11	2462	20.07	30.00	-2.50	17.57	36.00	Pass
11g	6Mbps	1	1	2412	20.29	30.00	-2.50	17.79	36.00	Pass
11g	6Mbps	1	6	2437	23.12	30.00	-2.50	20.62	36.00	Pass
11g	6Mbps	1	11	2462	23.01	30.00	-2.50	20.51	36.00	Pass
HT20	MCS0	1	1	2412	23.34	30.00	-2.50	20.84	36.00	Pass
HT20	MCS0	1	6	2437	23.11	30.00	-2.50	20.61	36.00	Pass
HT20	MCS0	1	11	2462	23.21	30.00	-2.50	20.71	36.00	Pass

TEST RESULTS DATA
Average Power Table
(Reporting Only)

2.4GHz Band						
Mod.	Data Rate	NTX	CH.	Freq. (MHz)	Duty Factor (dB)	Average Conducted Power (dBm)
11b	1Mbps	1	1	2412	0.00	18.06
11b	1Mbps	1	6	2437	0.00	18.98
11b	1Mbps	1	11	2462	0.00	18.02
11g	6Mbps	1	1	2412	0.09	16.12
11g	6Mbps	1	6	2437	0.09	18.16
11g	6Mbps	1	11	2462	0.09	18.22
HT20	MCS0	1	1	2412	0.06	18.21
HT20	MCS0	1	6	2437	0.06	18.07
HT20	MCS0	1	11	2462	0.06	18.14

TEST RESULTS DATA
Peak Power Density

2.4GHz Band								
Mod.	Data Rate	NTX	CH.	Freq. (MHz)	Peak PSD (dBm /3kHz)	DG (dBi)	Peak PSD Limit (dBm /3kHz)	Pass/Fail
11b	1Mbps	1	1	2412	-7.88	-2.50	8.00	Pass
11b	1Mbps	1	6	2437	-6.85	-2.50	8.00	Pass
11b	1Mbps	1	11	2462	-7.34	-2.50	8.00	Pass
11g	6Mbps	1	1	2412	-10.66	-2.50	8.00	Pass
11g	6Mbps	1	6	2437	-7.75	-2.50	8.00	Pass
11g	6Mbps	1	11	2462	-8.37	-2.50	8.00	Pass
HT20	MCS0	1	1	2412	-8.10	-2.50	8.00	Pass
HT20	MCS0	1	6	2437	-8.06	-2.50	8.00	Pass
HT20	MCS0	1	11	2462	-8.08	-2.50	8.00	Pass



Appendix B. AC Conducted Emission Test Results

Test Engineer :	Howard Huang	Temperature :	21~24°C
		Relative Humidity :	40~50%
Test Voltage :	120Vac / 60Hz	Phase :	Line

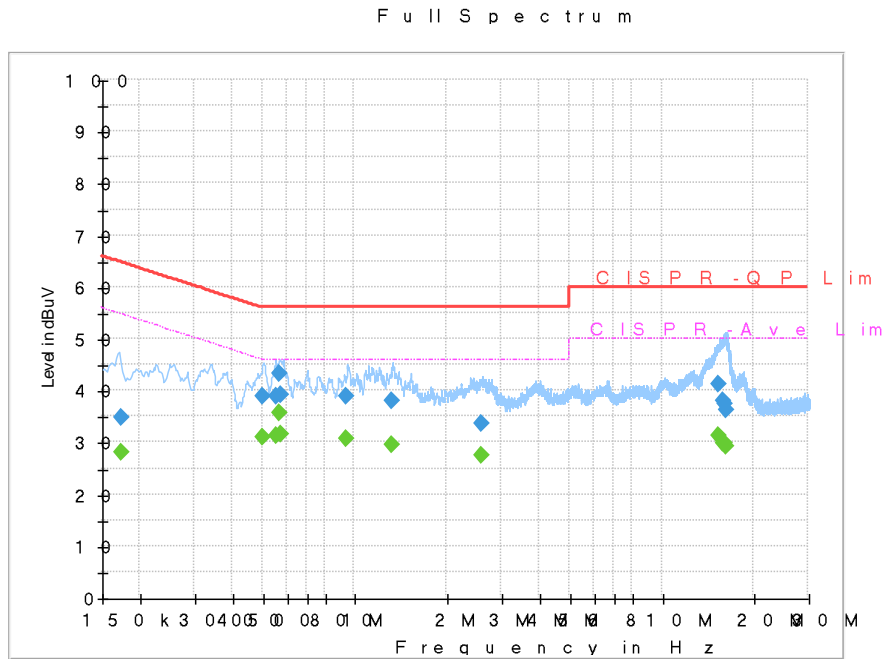

Final Result

Frequency	QuasiPeak	CAverage	Limit	Margin	Line	Filter	Corr.
0.174750	---	28.19	54.73	26.54	L1	OFF	19.6
0.174750	34.86	---	64.73	29.87	L1	OFF	19.6
0.500370	---	31.11	46.00	14.89	L1	OFF	19.6
0.500370	38.80	---	56.00	17.20	L1	OFF	19.6
0.555000	---	31.20	46.00	14.80	L1	OFF	19.6
0.555000	38.96	---	56.00	17.04	L1	OFF	19.6
0.569760	---	35.80	46.00	10.20	L1	OFF	19.6
0.569760	43.20	---	56.00	12.80	L1	OFF	19.6
0.577500	---	31.62	46.00	14.38	L1	OFF	19.6
0.577500	39.19	---	56.00	16.81	L1	OFF	19.6
0.944160	---	30.82	46.00	15.18	L1	OFF	19.6
0.944160	38.75	---	56.00	17.25	L1	OFF	19.6
1.325220	---	29.44	46.00	16.56	L1	OFF	19.6
1.325220	38.00	---	56.00	18.00	L1	OFF	19.6
2.587200	---	27.60	46.00	18.40	L1	OFF	19.6
2.587200	33.52	---	56.00	22.48	L1	OFF	19.6
15.291510	---	31.31	50.00	18.69	L1	OFF	20.2
15.291510	41.28	---	60.00	18.72	L1	OFF	20.2
15.776250	---	29.78	50.00	20.22	L1	OFF	20.2
15.776250	38.00	---	60.00	22.00	L1	OFF	20.2
15.945900	---	29.70	50.00	20.30	L1	OFF	20.3
15.945900	37.36	---	60.00	22.64	L1	OFF	20.3
16.134000	---	29.33	50.00	20.67	L1	OFF	20.3
16.134000	36.18	---	60.00	23.82	L1	OFF	20.3



Test Engineer :	Howard Huang	Temperature :	21~24°C
		Relative Humidity :	40~50%
Test Voltage :	120Vac / 60Hz	Phase :	Neutral

F u l l S p e c t r u m

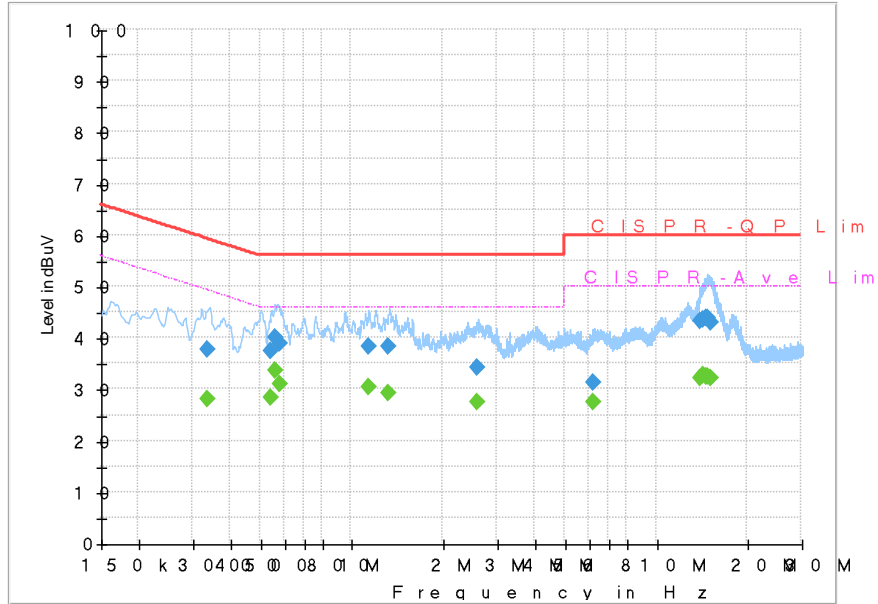

Final Result

Frequency	QuasiPeak	CAverage	Limit	Margin	Line	Filter	Corr.
0.336930	---	28.00	49.28	21.28	N	OFF	19.6
0.336930	37.73	---	59.28	21.55	N	OFF	19.6
0.546000	---	28.50	46.00	17.50	N	OFF	19.6
0.546000	37.29	---	56.00	18.71	N	OFF	19.6
0.562020	---	33.67	46.00	12.33	N	OFF	19.6
0.562020	40.09	---	56.00	15.91	N	OFF	19.6
0.579750	---	31.04	46.00	14.96	N	OFF	19.6
0.579750	38.81	---	56.00	17.19	N	OFF	19.6
1.137750	---	30.39	46.00	15.61	N	OFF	19.6
1.137750	38.25	---	56.00	17.75	N	OFF	19.6
1.319640	---	29.19	46.00	16.81	N	OFF	19.6
1.319640	38.37	---	56.00	17.63	N	OFF	19.6



Test Engineer :	Howard Huang	Temperature :	21~24°C
		Relative Humidity :	40~50%
Test Voltage :	120Vac / 60Hz	Phase :	Neutral

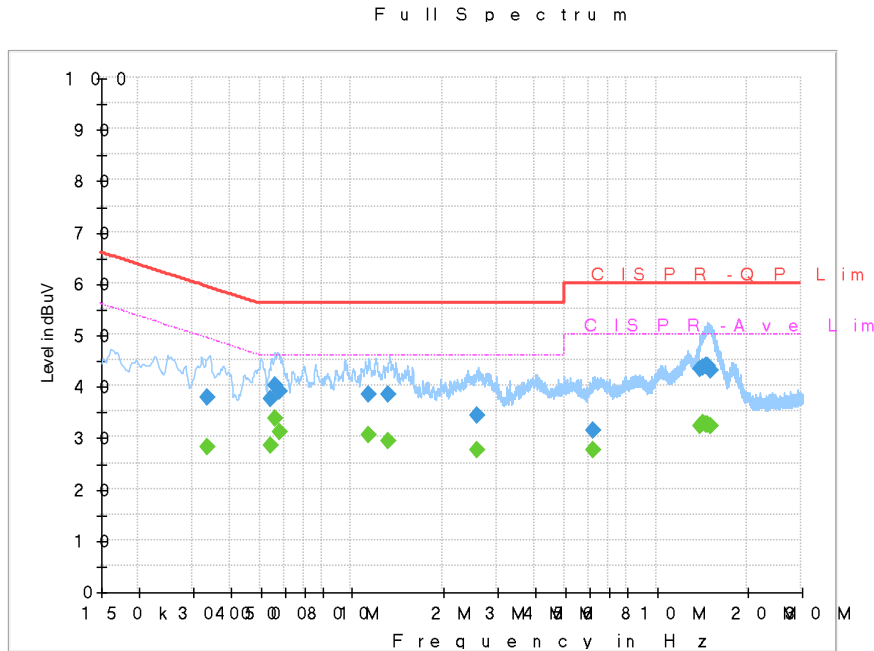

Final Result

Frequency	QuasiPeak	CAverage	Limit	Margin	Line	Filter	Corr.
2.577750	---	27.44	46.00	18.56	N	OFF	19.6
2.577750	34.27	---	56.00	21.73	N	OFF	19.6
6.211500	---	27.35	50.00	22.65	N	OFF	19.9
6.211500	31.38	---	60.00	28.62	N	OFF	19.9
14.055000	---	32.30	50.00	17.70	N	OFF	20.2
14.055000	43.17	---	60.00	16.83	N	OFF	20.2
14.307000	---	32.66	50.00	17.34	N	OFF	20.2
14.307000	43.70	---	60.00	16.30	N	OFF	20.2
14.575380	---	32.52	50.00	17.48	N	OFF	20.2
14.575380	43.82	---	60.00	16.18	N	OFF	20.2
14.868420	---	32.59	50.00	17.41	N	OFF	20.2
14.868420	43.84	---	60.00	16.16	N	OFF	20.2
15.164250	---	32.18	50.00	17.82	N	OFF	20.2
15.164250	42.96	---	60.00	17.04	N	OFF	20.2

Note:

1. Level(dBμV) = Read Level(dBμV) + LISN Factor(dB) + Cable Loss(dB)
2. Over Limit(dB) = Level(dBμV) – Limit Line(dBμV)



Appendix C. Radiated Spurious Emission

2.4GHz 2400~2483.5MHz

WIFI 802.11b (Band Edge @ 3m)

WIFI Ant.	Note	Frequency	Level	Over Limit	Limit Line	Read Level	Antenna Factor	Cable Loss	Preamp Factor	Ant Pos	Table Pos	Peak Avg.	Pol.
1		(MHz)	(dBμV/m)	(dB)	(dBμV/m)	(dBμV)	(dB/m)	(dB)	(dB)	(cm)	(deg)	(P/A)	(H/V)
802.11b CH 01 2412MHz		2389.43	54.27	-19.73	74	48.76	32.2	7.3	33.99	114	115	P	H
		2389.95	44.3	-9.7	54	38.79	32.2	7.3	33.99	114	115	A	H
	*	2412	107.6	-	-	102.08	32.16	7.34	33.98	114	115	P	H
	*	2410	104.25	-	-	98.73	32.16	7.34	33.98	114	115	A	H
		2385.53	53.98	-20.02	74	48.47	32.2	7.3	33.99	300	68	P	V
		2389.95	43.12	-10.88	54	37.61	32.2	7.3	33.99	300	68	A	V
	*	2412	103.74	-	-	98.22	32.16	7.34	33.98	300	68	P	V
	*	2410	100.44	-	-	94.92	32.16	7.34	33.98	300	68	A	V
802.11b CH 11 2462MHz		2486.8	58.51	-15.49	74	52.97	31.99	7.48	33.93	136	98	P	H
		2483.5	44.36	-9.64	54	38.83	31.99	7.48	33.94	136	98	A	H
	*	2462	109.06	-	-	103.54	32.03	7.44	33.95	136	98	P	H
	*	2460	105.79	-	-	100.27	32.03	7.44	33.95	136	98	A	H
		2485.42	54.02	-19.98	74	48.49	31.99	7.48	33.94	267	65	P	V
		2483.5	42.9	-11.1	54	37.37	31.99	7.48	33.94	267	65	A	V
	*	2462	103.48	-	-	97.96	32.03	7.44	33.95	267	65	P	V
	*	2460	100.17	-	-	94.65	32.03	7.44	33.95	267	65	A	V
Remark	1. No other spurious found. 2. All results are PASS against Peak and Average limit line.												



2.4GHz 2400~2483.5MHz

WIFI 802.11b (Harmonic @ 3m)

WIFI Ant. 1	Note	Frequency (MHz)	Level (dBμV/m)	Over Limit (dB)	Limit Line (dBμV/m)	Read Level (dBμV)	Antenna Factor (dB/m)	Cable Loss (dB)	Preamp Factor (dB)	Ant Pos (cm)	Table Pos (deg)	Peak Avg. (P/A)	Pol. (H/V)
802.11b		4824	52.59	-21.41	74	68.12	35.55	10.52	61.6	148	260	P	H
CH 01		4824	50.24	-3.76	54	65.77	35.55	10.52	61.6	148	260	A	H
2412MHz		4824	47.84	-26.16	74	63.37	35.55	10.52	61.6	100	0	P	V
802.11b		4872	53.1	-20.9	74	68.57	35.56	10.58	61.61	100	260	P	H
CH 06		4872	49.91	-4.09	54	65.38	35.56	10.58	61.61	100	260	A	H
2437MHz		7308	42.05	-31.95	74	52.94	37.82	13.62	62.33	300	0	P	H
		4872	47.52	-26.48	74	62.99	35.56	10.58	61.61	300	360	P	V
		7308	42.45	-31.55	74	53.34	37.82	13.62	62.33	300	360	P	V
802.11b		4926	52.73	-21.27	74	68.14	35.58	10.64	61.63	100	235	P	H
CH 11		4926	49.89	-4.11	54	65.3	35.58	10.64	61.63	100	235	A	H
2462MHz		7386	42.51	-31.49	74	53.31	37.99	13.58	62.37	100	360	P	H
		4926	48.27	-25.73	74	63.68	35.58	10.64	61.63	100	360	P	V
		7386	42.51	-31.49	74	53.31	37.99	13.58	62.37	100	360	P	V
Remark	1. No other spurious found. 2. All results are PASS against Peak and Average limit line.												



2.4GHz 2400~2483.5MHz

WIFI 802.11g (Band Edge @ 3m)

WIFI Ant. 1	Note	Frequency (MHz)	Level (dBμV/m)	Over Limit (dB)	Limit Line (dBμV/m)	Read Level (dBμV)	Antenna Factor (dB/m)	Cable Loss (dB)	Preamp Factor (dB)	Ant Pos (cm)	Table Pos (deg)	Peak Avg. (P/A)	Pol. (H/V)
802.11g CH 01 2412MHz		2389.82	61.51	-12.49	74	56	32.2	7.3	33.99	111	111	P	H
		2389.95	50.83	-3.17	54	45.32	32.2	7.3	33.99	111	111	A	H
	*	2410	108.64	-	-	103.12	32.16	7.34	33.98	111	111	P	H
	*	2410	100.56	-	-	95.04	32.16	7.34	33.98	111	111	A	H
		2389.95	57.58	-16.42	74	52.07	32.2	7.3	33.99	392	75	P	V
		2389.95	47.46	-6.54	54	41.95	32.2	7.3	33.99	392	75	A	V
	*	2410	104.96	-	-	99.44	32.16	7.34	33.98	392	75	P	V
	*	2410	97.02	-	-	91.5	32.16	7.34	33.98	392	75	A	V
802.11g CH 11 2462MHz		2483.68	60.55	-13.45	74	51	33.46	7.48	31.39	158	104	P	H
		2483.5	50.08	-3.92	54	40.53	33.46	7.48	31.39	158	104	A	H
	*	2460	106.36	-	-	96.9	33.42	7.44	31.4	158	104	P	H
	*	2460	98.56	-	-	89.1	33.42	7.44	31.4	158	104	A	H
		2486.32	58.11	-15.89	74	48.56	33.46	7.48	31.39	318	76	P	V
		2483.74	47.75	-6.25	54	38.2	33.46	7.48	31.39	318	76	A	V
	*	2464	100.32	-	-	90.86	33.42	7.44	31.4	318	76	P	V
	*	2462	92.44	-	-	82.98	33.42	7.44	31.4	318	76	A	V
Remark	1. No other spurious found. 2. All results are PASS against Peak and Average limit line.												



2.4GHz 2400~2483.5MHz

WIFI 802.11g (Harmonic @ 3m)

WIFI Ant. 1	Note	Frequency (MHz)	Level (dBμV/m)	Over Limit (dB)	Limit Line (dBμV/m)	Read Level (dBμV)	Antenna Factor (dB/m)	Cable Loss (dB)	Preamp Factor (dB)	Ant Pos (cm)	Table Pos (deg)	Peak Avg. (P/A)	Pol. (H/V)
802.11g		4824	54.98	-19.02	74	70.51	35.55	10.52	61.6	123	265	P	H
CH 01		4824	43.85	-10.15	54	59.38	35.55	10.52	61.6	123	265	A	H
2412MHz		4824	47.76	-26.24	74	63.29	35.55	10.52	61.6	300	360	P	V
802.11g CH 06 2437MHz		4872	56.56	-17.44	74	72.03	35.56	10.58	61.61	100	275	P	H
		4872	46.32	-7.68	54	61.79	35.56	10.58	61.61	100	275	A	H
		7308	43.99	-30.01	74	54.88	37.82	13.62	62.33	300	0	P	H
		4872	53.06	-20.94	74	68.53	35.56	10.58	61.61	100	275	P	V
		4872	43.19	-10.81	54	58.66	35.56	10.58	61.61	100	275	A	V
		7308	43.59	-30.41	74	54.48	37.82	13.62	62.33	300	360	P	V
802.11g CH 11 2462MHz		4926	57.93	-16.07	74	73.34	35.58	10.64	61.63	100	279	P	H
		4926	46.41	-7.59	54	61.82	35.58	10.64	61.63	100	279	A	H
		7386	44.3	-29.7	74	55.1	37.99	13.58	62.37	300	0	P	H
		4926	53.85	-20.15	74	70.74	34.1	10.64	61.63	100	93	P	V
		4926	41.72	-12.28	54	58.61	34.1	10.64	61.63	100	93	A	V
		7386	43.09	-30.91	74	55.38	36.5	13.58	62.37	300	360	P	V
Remark	1. No other spurious found. 2. All results are PASS against Peak and Average limit line.												



2.4GHz 2400~2483.5MHz

WIFI 802.11n HT20 (Band Edge @ 3m)

WIFI Ant. 1	Note	Frequency (MHz)	Level (dBμV/m)	Over Limit (dB)	Limit Line (dBμV/m)	Read Level (dBμV)	Antenna Factor (dB/m)	Cable Loss (dB)	Preamp Factor (dB)	Ant Pos (cm)	Table Pos (deg)	Peak Avg. (P/A)	Pol. (H/V)
802.11n HT20 CH 01 2412MHz		2389.56	60.12	-13.88	74	52.24	32	7.3	31.42	111	102	P	H
		2389.95	49.92	-4.08	54	42.03	32	7.3	31.41	111	102	A	H
	*	2410	107.92	-	-	99.86	32.13	7.34	31.41	111	102	P	H
	*	2410	99.21	-	-	91.15	32.13	7.34	31.41	111	102	A	H
		2388.39	58.85	-15.15	74	50.97	32	7.3	31.42	391	83	P	V
		2389.95	48.67	-5.33	54	40.78	32	7.3	31.41	391	83	A	V
	*	2410	105.69	-	-	97.63	32.13	7.34	31.41	391	83	P	V
	*	2410	97.42	-	-	89.36	32.13	7.34	31.41	391	83	A	V
802.11n HT20 CH 11 2462MHz		2483.5	60.93	-13.07	74	52.57	32.27	7.48	31.39	136	100	P	H
		2483.5	50.38	-3.62	54	42.02	32.27	7.48	31.39	136	100	A	H
	*	2464	107.32	-	-	98.95	32.33	7.44	31.4	136	100	P	H
	*	2460	99.01	-	-	90.64	32.33	7.44	31.4	136	100	A	H
		2484.28	59.75	-14.25	74	51.39	32.27	7.48	31.39	332	79	P	V
		2483.5	47.93	-6.07	54	39.57	32.27	7.48	31.39	332	79	A	V
	*	2460	104.22	-	-	95.85	32.33	7.44	31.4	332	79	P	V
	*	2458	95.77	-	-	87.4	32.33	7.44	31.4	332	79	A	V
Remark	1. No other spurious found. 2. All results are PASS against Peak and Average limit line.												



2.4GHz 2400~2483.5MHz

WIFI 802.11n HT20 (Harmonic @ 3m)

WIFI Ant. 1	Note	Frequency (MHz)	Level (dBμV/m)	Over Limit (dB)	Limit Line (dBμV/m)	Read Level (dBμV)	Antenna Factor (dB/m)	Cable Loss (dB)	Preamp Factor (dB)	Ant Pos (cm)	Table Pos (deg)	Peak Avg. (P/A)	Pol. (H/V)
802.11n HT20 CH 01 2412MHz		4824	56.57	-17.43	74	72.1	35.55	10.52	61.6	125	265	P	H
		4824	44.96	-9.04	54	60.49	35.55	10.52	61.6	125	365	A	H
		4824	49.55	-24.45	74	65.08	35.55	10.52	61.6	100	360	P	V
802.11n HT20 CH 06 2437MHz		4872	58.15	-15.85	74	73.62	35.56	10.58	61.61	100	275	P	H
		4872	46.45	-7.55	54	61.92	35.56	10.58	61.61	100	275	A	H
		7308	42.95	-31.05	74	53.84	37.82	13.62	62.33	100	360	P	H
		4872	54.37	-19.63	74	69.84	35.56	10.58	61.61	152	214	P	V
		4872	44.74	-9.26	54	60.21	35.56	10.58	61.61	152	214	A	V
		7308	42.75	-31.25	74	53.64	37.82	13.62	62.33	100	360	P	V
802.11n HT20 CH 11 2462MHz		4926	58.94	-15.06	74	74.35	35.58	10.64	61.63	100	278	P	H
		4926	47.11	-6.89	54	62.52	35.58	10.64	61.63	100	278	A	H
		7386	43.22	-30.78	74	54.02	37.99	13.58	62.37	300	0	P	H
		4926	55.65	-18.35	74	71.06	35.58	10.64	61.63	100	80	P	V
		4926	43.96	-10.04	54	59.37	35.58	10.64	61.63	100	80	A	V
		7386	43.77	-30.23	74	54.57	37.99	13.58	62.37	300	360	P	V
Remark	1. No other spurious found. 2. All results are PASS against Peak and Average limit line.												



2.4GHz 2400~2483.5MHz

Emission below 1GHz

2.4GHz WIFI 802.11g (LF)

WIFI Ant.	Note	Frequency	Level	Over Limit	Limit Line	Read Level	Antenna Factor	Cable Loss	Preamp Factor	Ant Pos	Table Pos	Peak Avg.	Pol.
1		(MHz)	(dBμV/m)	(dB)	(dBμV/m)	(dBμV)	(dB/m)	(dB)	(dB)	(cm)	(deg)	(P/A)	(H/V)
2.4GHz 802.11g LF		30.97	22.02	-17.98	40	29.43	24.57	1.1	33.08	-	-	P	H
		53.28	17.09	-22.91	40	35.33	13.65	1.27	33.16	-	-	P	H
		152.22	21.64	-21.86	43.5	35.68	16.98	1.98	33	-	-	P	H
		228.85	25.86	-20.14	46	40.03	16.29	2.38	32.84	-	-	P	H
		377.26	24.09	-21.91	46	32.46	21.14	3.02	32.53	-	-	P	H
		952.47	29.43	-16.57	46	25.82	30.98	4.72	32.09	100	0	P	H
		30.97	29.28	-10.72	40	36.69	24.57	1.1	33.08	100	360	P	V
		54.25	26.35	-13.65	40	44.85	13.4	1.28	33.18	-	-	P	V
		96.93	23.51	-19.99	43.5	39.14	15.71	1.64	32.98	-	-	P	V
		175.5	21.18	-22.32	43.5	36.66	15.37	2.1	32.95	-	-	P	V
		303.54	25.43	-20.57	46	35.96	19.44	2.74	32.71	-	-	P	V
		401.51	26.02	-19.98	46	33.24	21.95	3.13	32.3	-	-	P	V
Remark	1. No other spurious found. 2. All results are PASS against limit line.												



Note symbol

*	Fundamental Frequency which can be ignored. However, the level of any unwanted emissions shall not exceed the level of the fundamental frequency.
!	Test result is over limit line.
P/A	P eak or A verage
H/V	H orizontal or V ertical



A calculation example for radiated spurious emission is shown as below:

WIFI	Note	Frequency	Level	Over	Limit	Read	Antenna	Cable	Preamp	Ant	Table	Peak	Pol.
Ant.				Limit	Line	Level	Factor	Loss	Factor	Pos	Pos	Avg.	
2		(MHz)	(dBμV/m)	(dB)	(dBμV/m)	(dBμV)	(dB/m)	(dB)	(dB)	(cm)	(deg)	(P/A)	(H/V)
802.11b		2390	55.45	-18.55	74	54.51	32.22	4.58	35.86	103	308	P	H
CH 01													
2412MHz		2390	43.54	-10.46	54	42.6	32.22	4.58	35.86	103	308	A	H

- Level(dBμV/m) =
Antenna Factor(dB/m) + Cable Loss(dB) + Read Level(dBμV) - Preamp Factor(dB)
- Over Limit(dB) = Level(dBμV/m) – Limit Line(dBμV/m)

For Peak Limit @ 2390MHz:

- Level(dBμV/m)
= Antenna Factor(dB/m) + Cable Loss(dB) + Read Level(dBμV) - Preamp Factor(dB)
= 32.22(dB/m) + 4.58(dB) + 54.51(dBμV) – 35.86 (dB)
= 55.45 (dBμV/m)
- Over Limit(dB)
= Level(dBμV/m) – Limit Line(dBμV/m)
= 55.45(dBμV/m) – 74(dBμV/m)
= -18.55(dB)

For Average Limit @ 2390MHz:

- Level(dBμV/m)
= Antenna Factor(dB/m) + Cable Loss(dB) + Read Level(dBμV) - Preamp Factor(dB)
= 32.22(dB/m) + 4.58(dB) + 42.6(dBμV) – 35.86 (dB)
= 43.54 (dBμV/m)
- Over Limit(dB)
= Level(dBμV/m) – Limit Line(dBμV/m)
= 43.54(dBμV/m) – 54(dBμV/m)
= -10.46(dB)

Both peak and average measured complies with the limit line, so test result is “PASS”.



Appendix D. Duty Cycle Plots

Band	Duty Cycle(%)	T(ms)	1/T(kHz)	VBW Setting
802.11b	100	-	-	10Hz
802.11g	97.95	2.073	0.483	0.51KHz
802.11n HT20	98.52	-	-	10Hz

802.11b

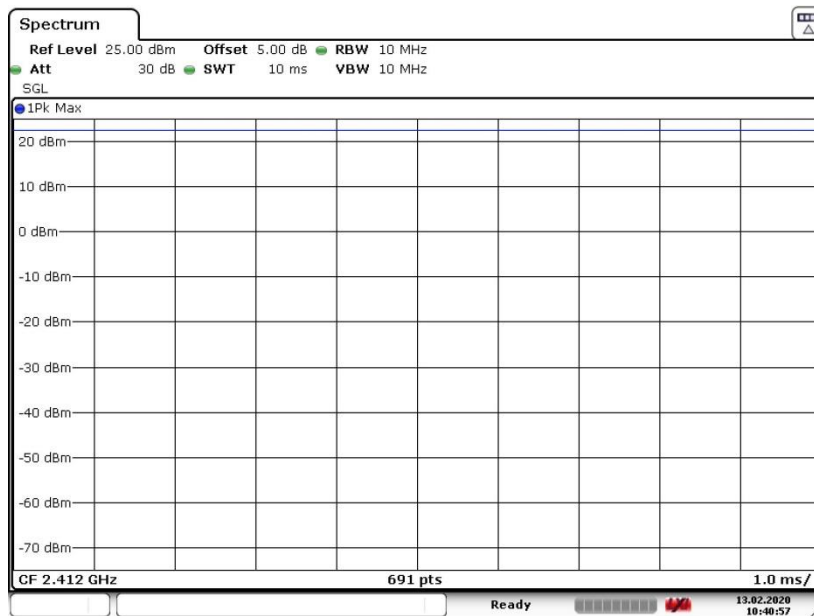



802.11g

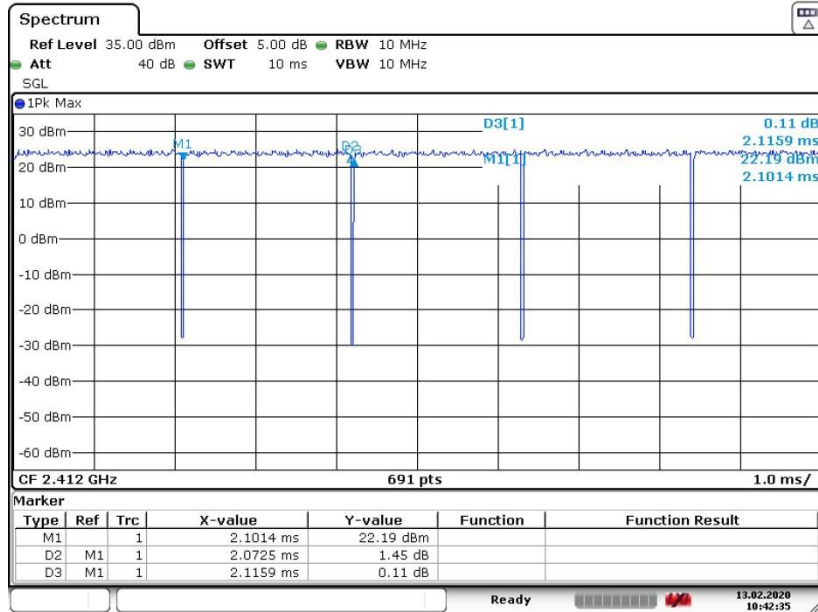

802.11n HT20

