



# FCC CO-LOCATION RADIO TEST REPORT

**FCC ID** : IHDT56YU2  
**Equipment** : Mobile Cellular Phone  
**Brand Name** : Motorola  
**Model Name** : XT2063-3  
**Applicant** : Motorola Mobility, LLC  
222 W Merchandise Mart Plaza, Suite 1800,  
Chicago, IL 60654, United States  
**Manufacturer** : Motorola Mobility, LLC  
222 W Merchandise Mart Plaza, Suite 1800,  
Chicago, IL 60654, United States  
**Standard** : 47 CFR Part 2, 22(H), 24(E)

The product was received on Jan. 30, 2020 and testing was started from Feb. 11, 2020 and completed on Feb. 13, 2020. We, SPORTON INTERNATIONAL INC. EMC & Wireless Communications Laboratory, would like to declare that the tested sample has been evaluated in accordance with the test procedures given in ANSI / TIA-603-E and has been in compliance with the applicable technical standards.

The report must not be used by the client to claim product certification, approval, or endorsement by TAF or any agency of government.

The test results in this report apply exclusively to the tested model / sample. Without written approval of SPORTON INTERNATIONAL INC. EMC & Wireless Communications Laboratory, the test report shall not be reproduced except in full.

*Louis Wu*

Approved by: Louis Wu

**SPORTON INTERNATIONAL INC. EMC & Wireless Communications Laboratory**  
No. 52, Huaya 1st Rd., Guishan Dist., Taoyuan City, Taiwan (R.O.C.)



## Table of Contents

History of this test report.....	3
Summary of Test Result.....	4
<b>1 General Description .....</b>	<b>5</b>
1.1 Product Feature of Equipment Under Test .....	5
1.2 Product Specification of Equipment Under Test .....	7
1.3 Modification of EUT .....	8
1.4 Testing Location .....	8
1.5 Applicable Standards .....	8
<b>2 Test Configuration of Equipment Under Test .....</b>	<b>9</b>
2.1 Test Mode.....	9
2.2 Connection Diagram of Test System .....	9
2.3 Support Unit used in test configuration .....	10
2.4 Frequency List of Low/Middle/High Channels.....	10
<b>3 Radiated Test Items .....</b>	<b>11</b>
3.1 Measuring Instruments.....	11
3.2 Test Setup .....	11
3.3 Test Result of Radiated Test.....	11
3.4 Field Strength of Spurious Radiation Measurement .....	12
<b>4 List of Measuring Equipment.....</b>	<b>13</b>
<b>5 Uncertainty of Evaluation.....</b>	<b>15</b>
<b>Appendix A. Test Results of Radiated Test</b>	



### History of this test report

Report No.	Version	Description	Issued Date
FG012201D	01	Initial issue of report	Apr. 10, 2020



### Summary of Test Result

Report Clause	Ref Std. Clause	Test Items	Result (PASS/FAIL)	Remark
3.4	§2.1053 §22.917 (a) §24.238 (a)	Field Strength of Spurious Radiation	Pass	Under limit 29.64 dB at 7403.000 MHz

**Declaration of Conformity:**

The test results with all measurement uncertainty excluded are presented in accordance with the regulation limits or requirements declared by manufacturers.

**Comments and Explanations:**

The declared of product specification for EUT presented in the report are provided by the manufacturer, and the manufacturer takes all the responsibilities for the accuracy of product specification.

**Reviewed by: Wii Chang**

**Report Producer: Ann Lee**



# 1 General Description

## 1.1 Product Feature of Equipment Under Test

Product Feature	
Equipment	Mobile Cellular Phone
Brand Name	Motorola
Model Name	XT2063-3
FCC ID	IHDT56YU2
IMEI Code	IMEI : 353585110016733 IMEI : 353585110016741
EUT supports Radios application	GSM/EGPRS/WCDMA/HSPA/LTE/5G NR/GNSS/NFC/FM WLAN 11b/g/n HT20 WLAN 11a/n HT20/HT40 WLAN 11ac VHT20/VHT40/VHT80 Bluetooth BR/EDR/LE
HW Version	DVT2
EUT Stage	Identical Prototype

Remark: The above EUT's information was declared by manufacturer.

Accessory List	
AC Adapter 1 (US)	Brand Name : Motorola
	Model Name : SC-51
	Manufacturer : Chenyang
AC Adapter 1 (EU)	Brand Name : Motorola
	Model Name : SC-52
	Manufacturer : Chenyang
AC Adapter 1 (UK)	Brand Name : Motorola
	Model Name : SC-53UK
	Manufacturer : Chenyang
AC Adapter 1 (AU)	Brand Name : Motorola
	Model Name : SC-55AU
	Manufacturer : Chenyang
AC Adapter 1 (AR)	Brand Name : Motorola
	Model Name : SC-56
	Manufacturer : Chenyang
AC Adapter 2 (US)	Brand Name : Motorola
	Model Name : SC-51
	Manufacturer : Acbel
AC Adapter 2 (EU)	Brand Name : Motorola
	Model Name : SC-52
	Manufacturer : Acbel
AC Adapter 2 (AR)	Brand Name : Motorola
	Model Name : SC-56
	Manufacturer : Acbel



<b>Accessory List</b>	
<b>AC Adapter 3 (Chile)</b>	Brand Name : Motorola
	Model Name : SC-52
	Manufacturer : Salom
<b>AC Adapter 3 (BR)</b>	Brand Name : Motorola
	Model Name : SC-57
	Manufacturer : Salom
<b>AC Adapter 3 (BR Local Build)</b>	Brand Name : Motorola
	Model Name : SC-57
	Manufacturer : Flex/Salom
<b>AC Adapter 4 (IN)</b>	Brand Name : Motorola
	Model Name : SC-54
	Manufacturer : Salom
<b>AC Adapter 5 (BR Local Build)</b>	Brand Name : Motorola
	Model Name : SC-57
	Manufacturer : Cliptech/Tenpao
<b>Battery</b>	Brand Name : ATL
	Model Name : LR50
<b>Earphone 1</b>	Brand Name : Motorola
	Model Name : SH38C37773
<b>Earphone 2</b>	Brand Name : Motorola
	Model Name : SH38C44959
<b>USB Cable 1</b>	Brand Name : Motorola
	Model Name : SC18C24367
	Manufacturer : Saibao
<b>USB Cable 2</b>	Brand Name : Motorola
	Model Name : SC18C24368
	Manufacturer : Luxshare
<b>USB Cable 3</b>	Brand Name : Motorola
	Model Name : SC18C28955
	Manufacturer : I SHENG



### 1.2 Product Specification of Equipment Under Test

Standards-related Product Specification	
<b>Tx Frequency</b>	<b>GSM:</b> GSM850: 824.2 MHz ~ 848.8 MHz GSM1900: 1850.2 MHz ~ 1909.8 MHz <b>WCDMA:</b> Band V: 1852.4 MHz ~ 1907.6 MHz Band II: 1852.4 MHz ~ 1907.6 MHz Band IV: 1712.4 MHz ~ 1752.6 MHz
<b>Rx Frequency</b>	<b>GSM:</b> GSM850: 869.2 MHz ~ 893.8 MHz GSM1900: 1930.2 MHz ~ 1989.8 MHz <b>WCDMA:</b> Band V: 1932.4 MHz ~ 1987.6 MHz Band II: 871.4 MHz ~ 891.6 MHz Band IV: 2112.4 MHz ~ 2152.6 MHz
<b>Antenna Type</b>	Fixed Internal Antenna
<b>Antenna Gain</b>	Cellular Band: -1.33 dBi PCS Band: 1.32 dBi AWS Band: 1.03
<b>Type of Modulation</b>	GSM / GPRS: GMSK EGPRS: GMSK for MCS 0 ~ 4 & 8PSK for MCS5 ~9 WCDMA: QPSK (Uplink) HSDPA: 64QAM (Downlink) / HSUPA : QPSK (Uplink)



### 1.3 Modification of EUT

No modifications are made to the EUT during all test items.

### 1.4 Testing Location

<b>Test Site</b>	SPORTON INTERNATIONAL INC. EMC & Wireless Communications Laboratory
<b>Test Site Location</b>	No.58, Aly. 75, Ln. 564, Wenhua 3rd, Rd., Guishan Dist., Taoyuan City, Taiwan (R.O.C.) TEL: +886-3-327-0868 FAX: +886-3-327-0855
<b>Test Site No.</b>	<b>Sporton Site No.</b> 03CH12-HY
<b>Test Engineer</b>	Jack Cheng, Lance Chiang, and Chuan Chu
<b>Temperature</b>	22.3~25.3°C
<b>Relative Humidity</b>	55.7~61.9%

**Note:** The test site complies with ANSI C63.4 2014 requirement.

FCC Designation No.: TW0007

### 1.5 Applicable Standards

According to the specifications of the manufacturer, the EUT must comply with the requirements of the following standards:

- ♦ ANSI C63.26-2015
- ♦ ANSI / TIA-603-E
- ♦ 47 CFR Part 2, 22(H), 24(E)
- ♦ FCC KDB 971168 D01 Power Meas. License Digital Systems v03r01
- ♦ FCC KDB Publication No. 558074 D01 DTS Meas. Guidance v05r02.

**Remark:**

1. All test items were verified and recorded according to the standards and without any deviation during the test.
2. This EUT has also been tested and complied with the requirements of FCC Part 15, Subpart B, recorded in a separate test report.



## 2 Test Configuration of Equipment Under Test

### 2.1 Test Mode

Antenna port conducted and radiated test items were performed according to KDB 971168 D01 Power Meas. License Digital Systems v03r01 with maximum output power.

For radiated measurement, pre-scanned in three orthogonal panels, X, Y, Z. The worst cases (Y plane) were recorded in this report.

Radiated emissions were investigated as following frequency range:

1. 30 MHz to 19100 MHz for GSM1900

All modes and data rates and positions were investigated.

Test modes are chosen to be reported as the worst case configuration below:

Test Modes	
Band	Radiated TCs
GSM1900	■ GPRS Class 8 Link

Remark:

1. All the radiated test cases were performed with Adapter 1 (US), Earphone 1 and USB Cable 1.
2. During the Radiated Spurious Emission test, the EUT turn on the WLAN functions simultaneously.

### 2.2 Connection Diagram of Test System

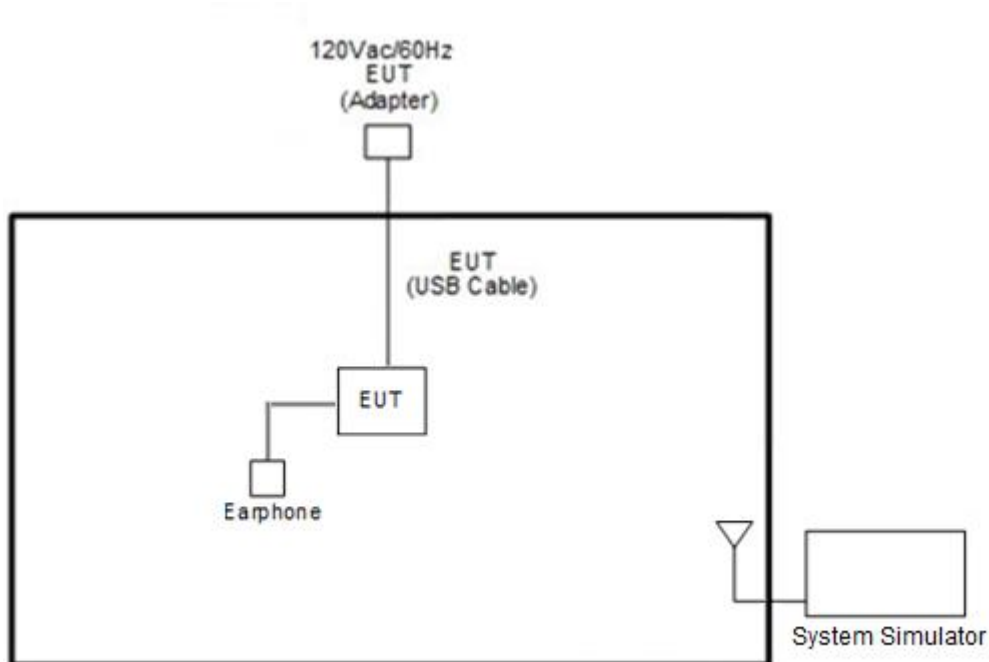



### 2.3 Support Unit used in test configuration

Item	Equipment	Trade Name	Model No.	FCC ID	Data Cable	Power Cord
1.	System Simulator	R&S	CMU 200	N/A	N/A	Unshielded, 1.8 m

### 2.4 Frequency List of Low/Middle/High Channels

Frequency List				
Band	Channel/Frequency(MHz)	Lowest	Middle	Highest
GSM1900	Channel	512	661	810
	Frequency	1850.2	1880.0	1909.8

### 3 Radiated Test Items

#### 3.1 Measuring Instruments

See list of measuring instruments of this test report.

#### 3.2 Test Setup

For radiated test from 30MHz to 1GHz

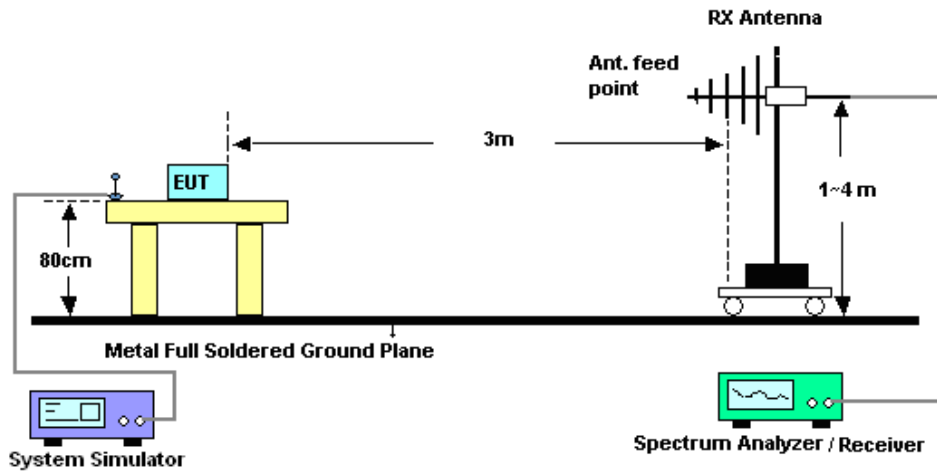

For radiated test above 1GHz

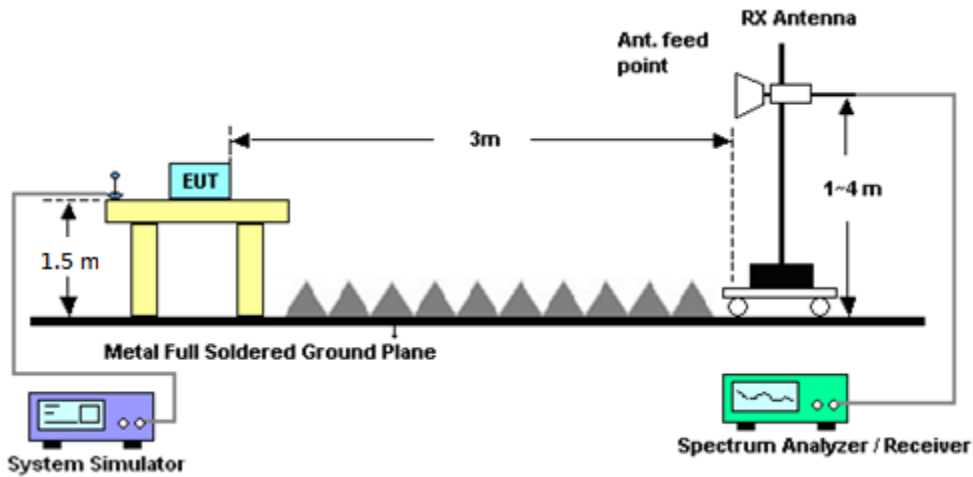

#### 3.3 Test Result of Radiated Test

Please refer to Appendix A.



### 3.4 Field Strength of Spurious Radiation Measurement

#### 3.4.1 Description of Field Strength of Spurious Radiated Measurement

The power of any emission outside of the authorized operating frequency ranges must be attenuated below the transmitter power (P) by a factor of at least  $43 + 10 \log (P)$  dB. The spectrum is scanned from 30 MHz up to a frequency including its 10th harmonic.

#### 3.4.2 Test Procedures

The testing follows FCC KDB 971168 D01 v03r01 Section 7 and ANSI / TIA-603-E Section 2.2.12.

1. The EUT was placed on a rotatable wooden table 0.8 meters for frequency below 1GHz and 1.5 meter for frequency above 1GHz above the ground.
2. The EUT was set 3 meters from the receiving antenna, which was mounted on the antenna tower.
3. The table was rotated 360 degrees to determine the position of the highest spurious emission.
4. The height of the receiving antenna is varied between one meter and four meters to search for the maximum spurious emission for both horizontal and vertical polarizations.
5. Make the measurement with the spectrum analyzer's RBW = 1MHz, VBW = 3MHz, taking record of maximum spurious emission.
6. A horn antenna was substituted in place of the EUT and was driven by a signal generator.
7. Tune the output power of signal generator to the same emission level with EUT maximum spurious emission.
8. Taking the record of output power at antenna port.
9. Repeat step 7 to step 8 for another polarization.
10.  $EIRP (dBm) = S.G. Power - Tx Cable Loss + Tx Antenna Gain$
11.  $ERP (dBm) = EIRP - 2.15$
12. The RF fundamental frequency should be excluded against the limit line in the operating frequency band.
13. The limit line is derived from  $43 + 10\log(P)$  dB below the transmitter power P(Watts)



## 4 List of Measuring Equipment

Instrument	Manufacturer	Model No.	Serial No.	Characteristics	Calibration Date	Test Date	Due Date	Remark
Loop Antenna	Rohde & Schwarz	HFH2-Z2	100315	9 kHz~30 MHz	Dec. 26, 2019	Feb. 11, 2020~ Feb. 13, 2020	Dec. 25, 2020	Radiation (03CH12-HY)
Bilog Antenna	TESEQ	CBL 6111D & 00800N1D01 N-06	37059 & 01	30MHz~1GHz	Oct. 12, 2019	Feb. 11, 2020~ Feb. 13, 2020	Oct 11, 2020	Radiation (03CH12-HY)
Horn Antenna	SCHWARZBE CK	BBHA 9120D	9120D-132 8	1GHz ~ 18GHz	Nov. 14, 2019	Feb. 11, 2020~ Feb. 13, 2020	Nov. 13, 2020	Radiation (03CH12-HY)
SHF-EHF Horn Antenna	SCHWARZBE CK	BBHA 9170	BBHA9170 584	18GHz ~ 40GHz	Dec. 10, 2019	Feb. 11, 2020~ Feb. 13, 2020	Dec. 09, 2020	Radiation (03CH12-HY)
Preamplifier	COM-POWER	PA-103	161075	10MHz~1GHz	Mar. 25, 2019	Feb. 11, 2020~ Feb. 13, 2020	Mar. 24, 2020	Radiation (03CH12-HY)
Preamplifier	Jet-Power	JPA00101800 -30-10P	160118000 2	1GHz~18GHz	Aug. 01, 2019	Feb. 11, 2020~ Feb. 13, 2020	Jul. 01, 2020	Radiation (03CH12-HY)
Preamplifier	EMEC	EM18G40G	060715	18GHz ~ 40GHz	Dec. 13, 2019	Feb. 11, 2020~ Feb. 13, 2020	Dec. 12, 2020	Radiation (03CH12-HY)
Preamplifier	Agilent	8449B	3008A023 75	1GHz~26.5GHz	May 27, 2019	Feb. 11, 2020~ Feb. 13, 2020	May 26, 2020	Radiation (03CH12-HY)
Spectrum Analyzer	Keysight	N9010A	MY553705 26	10Hz~44GHz	Mar. 19, 2019	Feb. 11, 2020~ Feb. 13, 2020	Mar. 18, 2020	Radiation (03CH12-HY)
Signal Generator	Rohde & Schwarz	SMB100A	101107	100kHz~40GHz	Aug. 27, 2019	Feb. 11, 2020~ Feb. 13, 2020	Aug. 26, 2020	Radiation (03CH12-HY)
Hygrometer	TECPEL	DTM-303B	TP161243	N/A	May 11, 2019	Feb. 11, 2020~ Feb. 13, 2020	May 10, 2020	Radiation (03CH12-HY)
RF Cable	HUBER + SUHNER	SUCOFLEX 126E	0058/126E	30M-18G	Mar. 13, 2019	Feb. 11, 2020~ Feb. 13, 2020	Mar. 12, 2020	Radiation (03CH12-HY)
RF Cable	HUBER + SUHNER	SUCOFLEX 102	505134/2	30M~40GHz	Feb. 26, 2019	Feb. 11, 2020~ Feb. 13, 2020	Feb. 25, 2020	Radiation (03CH12-HY)
RF Cable	HUBER + SUHNER	SUCOFLEX 102	800740/2	30M~40GHz	Feb. 26, 2019	Feb. 11, 2020~ Feb. 13, 2020	Feb. 25, 2020	Radiation (03CH12-HY)
Controller	EMEC	EM1000	N/A	Control Turn table & Ant Mast	N/A	Feb. 11, 2020~ Feb. 13, 2020	N/A	Radiation (03CH12-HY)
Antenna Mast	EMEC	AM-BS-4500- B	N/A	1m~4m	N/A	Feb. 11, 2020~ Feb. 13, 2020	N/A	Radiation (03CH12-HY)
Turn Table	EMEC	TT2000	N/A	0~360 Degree	N/A	Feb. 11, 2020~ Feb. 13, 2020	N/A	Radiation (03CH12-HY)
Software	Audix	E3 6.2009-8-24	RK-00098 9	N/A	N/A	Feb. 11, 2020~ Feb. 13, 2020	N/A	Radiation (03CH12-HY)



Instrument	Manufacturer	Model No.	Serial No.	Characteristics	Calibration Date	Test Date	Due Date	Remark
EMI Test Receiver	Agilent	N9038A (MXE)	MY532900 45	20MHz~8.4GHz	Jan. 18, 2020	Feb. 11, 2020~ Feb. 13, 2020	Jan. 17, 2021	Radiation (03CH12-HY)
Notch Filter	Wainwright	WRCG1710/1 755-1690/177 5-45/7SS	SN2	AWS Band	Nov. 05, 2019	Feb. 11, 2020~ Feb. 13, 2020	Nov. 04, 2020	Radiation (03CH12-HY)
Notch Filter	Wainwright	WRCT2500/2 570-10/40-10 SSK	SN1 R	LTE Band 7	Aug. 22, 2019	Feb. 11, 2020~ Feb. 13, 2020	Aug. 21, 2020	Radiation (03CH12-HY)
Filter	Wainwright	WLKS1200-1 2SS	SN2	1.2GHz Low Pass	Mar. 22, 2019	Feb. 11, 2020~ Feb. 13, 2020	Mar. 21, 2020	Radiation (03CH12-HY)
Filter	Wainwright	WHKX12-108 0-1200-1500- 60ST	SN1	1.2G High Pass	Mar. 19, 2019	Feb. 11, 2020~ Feb. 13, 2020	Mar. 18, 2020	Radiation (03CH12-HY)
Filter	Wainwright	WHKX12-270 0-3000-18000 -60ST	SN2	3G High Pass	Jul. 15, 2019	Feb. 11, 2020~ Feb. 13, 2020	Jul. 14, 2020	Radiation (03CH12-HY)



## 5 Uncertainty of Evaluation

### Uncertainty of Radiated Emission Measurement (30 MHz ~ 1000 MHz)

Measuring Uncertainty for a Level of Confidence of 95% ( $U = 2Uc(y)$ )	3.24
---	------

### Uncertainty of Radiated Emission Measurement (1 GHz ~ 18 GHz)

Measuring Uncertainty for a Level of Confidence of 95% ( $U = 2Uc(y)$ )	3.62
---	------

### Uncertainty of Radiated Emission Measurement (18 GHz ~ 40 GHz)

Measuring Uncertainty for a Level of Confidence of 95% ( $U = 2Uc(y)$ )	4.06
---	------



### Appendix A. Test Results of Radiated Test

### GPRS 1900

GPRS 1900									
Channel	Frequency ( MHz )	EIRP ( dBm )	Limit ( dBm )	Over Limit ( dB )	SPA Reading (dBm)	S.G. Power ( dBm )	TX Cable loss ( dB )	TX Antenna Gain (dBi)	Polarization (H/V)
Lowest	3700	-51.82	-13	-38.82	-74.57	-63.03	1.41	12.62	H
	5548	-47.22	-13	-34.22	-74.95	-58.78	1.74	13.30	H
	7403	-42.64	-13	-29.64	-73.57	-51.96	1.94	11.26	H
									H
									H
									H
									H
	3700	-51.70	-13	-38.70	-74.59	-62.91	1.41	12.62	V
	5548	-47.88	-13	-34.88	-75.12	-59.44	1.74	13.30	V
	7403	-43.05	-13	-30.05	-73.82	-52.37	1.94	11.26	V
									V
									V
									V
									V

Remark: Spurious emissions within 30-1000MHz were found more than 20dB below limit line.

—————THE END—————