

# FCC SAR Test Report

APPLICANT : Motorola Mobility LLC  
EQUIPMENT : Mobile Cellular Phone  
BRAND NAME : Motorola  
MODEL NAME : XT2045-1  
FCC ID : IHDT56YK2  
STANDARD : FCC 47 CFR Part 2 (2.1093)  
ANSI/IEEE C95.1-1992  
IEEE 1528-2013

The product was received on Oct. 21, 2019 and testing was started from Nov. 12, 2019 and completed on Nov. 21, 2019. We, Sporton International (Kunshan) Inc, would like to declare that the tested sample has been evaluated in accordance with the procedures and had been in compliance with the applicable technical standards.

The test results in this report apply exclusively to the tested model / sample. Without written approval of Sporton International (Kunshan) Inc., the test report shall not be reproduced except in full.

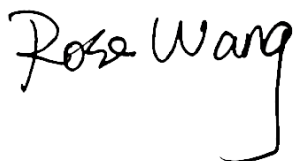

Reviewed by: Rose Wang / Supervisor



Approved by: Kat Yin / Manager



**Sporton International (Kunshan) Inc.**  
No. 1098, Pengxi North Road, Kunshan Economic Development Zone Jiangsu Province 215300  
People's Republic of China



Table of Contents

1. Statement of Compliance ..... 4
2. Administration Data ..... 5
3. Guidance Applied ..... 5
4. Equipment Under Test (EUT) Information ..... 6
4.1 General Information ..... 6
4.2 General LTE SAR Test and Reporting Considerations ..... 7
5. Proximity Sensor Triggering Test ..... 9
5.1 Proximity sensor triggering distances(Per KDB616217§6.2) ..... 9
6. RF Exposure Limits ..... 22
6.1 Uncontrolled Environment ..... 22
6.2 Controlled Environment ..... 22
7. Specific Absorption Rate (SAR) ..... 23
7.1 Introduction ..... 23
7.2 SAR Definition ..... 23
8. System Description and Setup ..... 24
8.1 E-Field Probe ..... 25
8.2 Data Acquisition Electronics (DAE) ..... 25
8.3 Phantom ..... 26
8.4 Device Holder ..... 27
9. Measurement Procedures ..... 28
9.1 Spatial Peak SAR Evaluation ..... 28
9.2 Power Reference Measurement ..... 29
9.3 Area Scan ..... 29
9.4 Zoom Scan ..... 30
9.5 Volume Scan Procedures ..... 30
9.6 Power Drift Monitoring ..... 30
10. Test Equipment List ..... 31
11. System Verification ..... 32
11.1 Tissue Simulating Liquids ..... 32
11.2 Tissue Verification ..... 33
11.3 System Performance Check Results ..... 34
12. RF Exposure Positions ..... 35
12.1 Ear and handset reference point ..... 35
12.2 Definition of the cheek position ..... 36
12.3 Definition of the tilt position ..... 37
12.4 Body Worn Accessory ..... 38
12.5 Product Specific 10g SAR Exposure ..... 39
12.6 Wireless Router ..... 39
13. Conducted RF Output Power (Unit: dBm) ..... 40
14. Antenna Location ..... 86
15. SAR Test Results ..... 87
15.1 Head SAR ..... 90
15.2 Hotspot SAR ..... 93
15.3 Body Worn Accessory SAR ..... 97
15.4 Product specific 10g SAR ..... 100
15.5 Repeated SAR Measurement ..... 102
16. Simultaneous Transmission Analysis ..... 103
16.1 Head Exposure Conditions ..... 104
16.2 Hotspot Exposure Conditions ..... 105
16.3 Body-Worn Accessory Exposure Conditions ..... 107
16.4 SPLSR Evaluation and Analysis ..... 108
17. Uncertainty Assessment ..... 118
18. References ..... 119
Appendix A. Plots of System Performance Check
Appendix B. Plots of High SAR Measurement
Appendix C. DASy Calibration Certificate
Appendix D. Test Setup Photos





### 1. Statement of Compliance

The maximum results of Specific Absorption Rate (SAR) found during testing for **Motorola Mobility LLC, Mobile Cellular Phone, XT2045-1**, are as follows.

Highest 1g SAR Summary						
Equipment Class	Frequency Band		Head (Separation 0mm)	Hotspot (Separation 5mm)	Body-worn (Separation 5mm)	Highest Simultaneous Transmission 1g SAR (W/kg)
			1g SAR (W/kg)			
Licensed	GSM	GSM850	0.55	1.39	1.39	1.56
		GSM1900	0.15	1.41	1.41	
	WCDMA	Band II	0.29	1.34	1.34	
		Band IV	0.17	1.37	1.44	
		Band V	0.54	1.30	1.30	
	LTE	Band 2	0.29	1.39	1.39	
		Band 5	0.81	1.38	1.38	
		Band 7	0.23	1.33	1.33	
		Band 66/Band 4	0.12	1.31	1.31	
DTS	WLAN	2.4GHz WLAN	1.03	1.03	1.03	1.56
DSS	Bluetooth	2.4GHz Bluetooth	<0.10	<0.10	<0.10	1.47
Highest 10g SAR Summary						
Equipment Class	Frequency Band		Product Specific 10g SAR (W/kg) (Separation 0mm)			
Licensed	GSM	GSM850	1.72			
		GSM1900	3.26			
	WCDMA	Band II	3.37			
		Band IV	3.47			
		Band V	2.97			
	LTE	Band 2	3.39			
		Band 5	2.00			
		Band 7	3.46			
		Band 66/Band 4	3.43			
Date of Testing:			2019/11/12~2019/11/21			
<b>Remark:</b> This device supports LTE B4 and B66. Since the supported frequency span for LTE B4 falls completely within the supports frequency span for LTE B66, both LTE bands have the same target power, and both LTE bands share the same transmission path; therefore, SAR was only assessed for LTE B66.						

**Declaration of Conformity:**

The test results with all measurement uncertainty excluded are presented in accordance with the regulation limits or requirements declared by manufacturers.

**Comments and Explanations:**

The declared of product specification for EUT presented in the report are provided by the manufacturer, and the manufacturer takes all the responsibilities for the accuracy of product specification.

This device is in compliance with Specific Absorption Rate (SAR) for general population/uncontrolled exposure limits (1.6 W/kg for Partial-Body 1g SAR, 4.0 W/kg for Product Specific 10g SAR) specified in FCC 47 CFR part 2 (2.1093) and ANSI/IEEE C95.1-1992, and had been tested in accordance with the measurement methods and procedures specified in IEEE 1528-2013 and FCC KDB publications.



### 2. Administration Data

Sporton International (Kunshan) Inc. is accredited to ISO/IEC 17025:2017 by American Association for Laboratory Accreditation with Certificate Number 5145.02.

Testing Laboratory		
Test Firm	Sporton International (Kunshan) Inc.	
Test Site Location	No. 1098, Pengxi North Road, Kunshan Economic Development Zone Jiangsu Province 215300 People's Republic of China TEL : +86-512-57900158 FAX : +86-512-57900958	
Test Site No.	FCC Designation No.	FCC Test Firm Registration No.
	CN1257	314309

Applicant	
Company Name	Motorola Mobility LLC
Address	222 W, Merchandise Mart Plaza, Chicago IL 60654 USA

Manufacturer	
Company Name	Motorola Mobility LLC
Address	222 W, Merchandise Mart Plaza, Chicago IL 60654 USA

### 3. Guidance Applied

The Specific Absorption Rate (SAR) testing specification, method, and procedure for this device is in accordance with the following standards:

- FCC 47 CFR Part 2 (2.1093)
- ANSI/IEEE C95.1-1992
- IEEE 1528-2013
- FCC KDB 865664 D01 SAR Measurement 100 MHz to 6 GHz v01r04
- FCC KDB 865664 D02 SAR Reporting v01r02
- FCC KDB 447498 D01 General RF Exposure Guidance v06
- FCC KDB 648474 D04 SAR Evaluation Considerations for Wireless Handsets v01r03
- FCC KDB 248227 D01 802.11 Wi-Fi SAR v02r02
- FCC KDB 616217 D04 SAR for laptop and tablets v01r02
- FCC KDB 941225 D01 3G SAR Procedures v03r01
- FCC KDB 941225 D05 SAR for LTE Devices v02r05
- FCC KDB 941225 D06 Hotspot Mode SAR v02r01

## **4. Equipment Under Test (EUT) Information**

### **4.1 General Information**

<b>Product Feature &amp; Specification</b>	
<b>Equipment Name</b>	Mobile Cellular Phone
<b>Brand Name</b>	Motorola
<b>Model Name</b>	XT2045-1
<b>FCC ID</b>	IHDT56YK2
<b>IMEI Code</b>	SIM1: 359107100046879 SIM2: 359107100046887
<b>Wireless Technology and Frequency Range</b>	GSM850: 824.2 MHz ~ 848.8 MHz GSM1900: 1850.2 MHz ~ 1909.8 MHz WCDMA Band II: 1852.4 MHz ~ 1907.6 MHz WCDMA Band IV: 1712.4 MHz ~ 1752.6 MHz WCDMA Band V: 826.4 MHz ~ 846.6 MHz LTE Band 2: 1850.7 MHz ~ 1909.3 MHz LTE Band 4: 1710.7 MHz ~ 1754.3 MHz LTE Band 5: 824.7 MHz ~ 848.3 MHz LTE Band 7: 2502.5 MHz ~ 2567.5 MHz LTE Band 66: 1710.7 MHz ~ 1779.3 MHz WLAN 2.4GHz Band: 2412 MHz ~ 2462 MHz Bluetooth: 2402 MHz ~ 2480 MHz
<b>Mode</b>	GSM/GPRS/EGPRS RMC/AMR 12.2Kbps HSDPA HSUPA DC-HSDPA HSPA+(16QAM uplink is not supported) LTE: QPSK, 16QAM, 64QAM WLAN 2.4GHz 802.11b/g/n HT20 Bluetooth BR/EDR/LE
<b>HW Version</b>	DVT2
<b>SW Version</b>	QPJ30.36
<b>GSM / (E)GPRS Transfer mode</b>	Class B – EUT cannot support Packet Switched and Circuit Switched Network simultaneously but can automatically switch between Packet and Circuit Switched Network.
<b>EUT Stage</b>	Identical Prototype
<b>Remark:</b>	
<ol style="list-style-type: none"> <li>802.11n-HT40 is not supported in 2.4GHz WLAN.</li> <li>This device supports VoIP in GPRS, EGPRS, WCDMA and LTE (e.g. for 3rd-party VoIP), LTE supports VoLTE operation.</li> <li>This device 2.4GHz WLAN support hotspot operation and Bluetooth support tethering applications.</li> <li>This device does not support DTM operation and supports GRPS/EGRPS mode up to multi-slot class 12.</li> <li>The device employs proximity sensors that detect the presence of the user's body at the front or back faces of the device. When front or back body worn condition is detected, GSM850/1900, WCDMA band II/IV/V and LTE band 2/4/7/66 reduced power will be active. (P-sensor can't work at detecting presence of the user's body at the four edges of the device.)</li> <li>P-sensor can detect handheld state, WCDMA band II/IV, and LTE band 2/4/7/66 for front/back/bottom sides of product specific 10g SAR condition reduced powers will be active.</li> <li>When hotspot mode is enabled, power reduction will be activated to limit the maximum power of GSM850/1900, WCDMA band II/IV/V and LTE band 2/4/7/66.</li> <li>For dual SIM card mobile has two SIM slots and supports dual SIM dual standby. The WWAN radio transmission will be enabled by either one SIM at a time (single active). After pre-scan two SIM cards power, we found test result of the SIM1 was the worse, so we chose SIM1 slot to perform all tests.</li> <li>There are three type of headsets, they are only with different suppliers. We only chose headset 1 to perform full SAR.</li> </ol>	

**4.2 General LTE SAR Test and Reporting Considerations**

Summarized necessary items addressed in KDB 941225 D05 v02r05																																																															
FCC ID	IHDT56YK2																																																														
Equipment Name	Mobile Cellular Phone																																																														
Operating Frequency Range of each LTE transmission band	LTE Band 2: 1850.7 MHz ~ 1909.3 MHz LTE Band 4: 1710.7 MHz ~ 1754.3 MHz LTE Band 5: 824.7 MHz ~ 848.3 MHz LTE Band 7: 2502.5 MHz ~ 2567.5 MHz LTE Band 66: 1710.7 MHz ~ 1779.3 MHz																																																														
Channel Bandwidth	LTE Band 2: 1.4MHz, 3MHz, 5MHz, 10MHz, 15MHz, 20MHz LTE Band 4: 1.4MHz, 3MHz, 5MHz, 10MHz, 15MHz, 20MHz LTE Band 5: 1.4MHz, 3MHz, 5MHz, 10MHz LTE Band 7: 5MHz, 10MHz, 15MHz, 20MHz LTE Band 66: 1.4MHz, 3MHz, 5MHz, 10MHz, 15MHz, 20MHz																																																														
uplink modulations used	QPSK / 16QAM / 64QAM																																																														
LTE Voice / Data requirements	Voice and Data																																																														
LTE Release Version	R12, Cat13																																																														
CA Support	Not supported,																																																														
LTE MPR permanently built-in by design	<p><b>Table 6.2.3-1: Maximum Power Reduction (MPR) for Power Class 1, 2 and 3</b></p> <table border="1"> <thead> <tr> <th rowspan="2">Modulation</th> <th colspan="6">Channel bandwidth / Transmission bandwidth (N<sub>RB</sub>)</th> <th rowspan="2">MPR (dB)</th> </tr> <tr> <th>1.4 MHz</th> <th>3.0 MHz</th> <th>5 MHz</th> <th>10 MHz</th> <th>15 MHz</th> <th>20 MHz</th> </tr> </thead> <tbody> <tr> <td>QPSK</td> <td>&gt; 5</td> <td>&gt; 4</td> <td>&gt; 8</td> <td>&gt; 12</td> <td>&gt; 16</td> <td>&gt; 18</td> <td>≤ 1</td> </tr> <tr> <td>16 QAM</td> <td>≤ 5</td> <td>≤ 4</td> <td>≤ 8</td> <td>≤ 12</td> <td>≤ 16</td> <td>≤ 18</td> <td>≤ 1</td> </tr> <tr> <td>16 QAM</td> <td>&gt; 5</td> <td>&gt; 4</td> <td>&gt; 8</td> <td>&gt; 12</td> <td>&gt; 16</td> <td>&gt; 18</td> <td>≤ 2</td> </tr> <tr> <td>64 QAM</td> <td>≤ 5</td> <td>≤ 4</td> <td>≤ 8</td> <td>≤ 12</td> <td>≤ 16</td> <td>≤ 18</td> <td>≤ 2</td> </tr> <tr> <td>64 QAM</td> <td>&gt; 5</td> <td>&gt; 4</td> <td>&gt; 8</td> <td>&gt; 12</td> <td>&gt; 16</td> <td>&gt; 18</td> <td>≤ 3</td> </tr> <tr> <td>256 QAM</td> <td colspan="6">≥ 1</td> <td>≤ 5</td> </tr> </tbody> </table>	Modulation	Channel bandwidth / Transmission bandwidth (N <sub>RB</sub> )						MPR (dB)	1.4 MHz	3.0 MHz	5 MHz	10 MHz	15 MHz	20 MHz	QPSK	> 5	> 4	> 8	> 12	> 16	> 18	≤ 1	16 QAM	≤ 5	≤ 4	≤ 8	≤ 12	≤ 16	≤ 18	≤ 1	16 QAM	> 5	> 4	> 8	> 12	> 16	> 18	≤ 2	64 QAM	≤ 5	≤ 4	≤ 8	≤ 12	≤ 16	≤ 18	≤ 2	64 QAM	> 5	> 4	> 8	> 12	> 16	> 18	≤ 3	256 QAM	≥ 1						≤ 5
Modulation	Channel bandwidth / Transmission bandwidth (N <sub>RB</sub> )						MPR (dB)																																																								
	1.4 MHz	3.0 MHz	5 MHz	10 MHz	15 MHz	20 MHz																																																									
QPSK	> 5	> 4	> 8	> 12	> 16	> 18	≤ 1																																																								
16 QAM	≤ 5	≤ 4	≤ 8	≤ 12	≤ 16	≤ 18	≤ 1																																																								
16 QAM	> 5	> 4	> 8	> 12	> 16	> 18	≤ 2																																																								
64 QAM	≤ 5	≤ 4	≤ 8	≤ 12	≤ 16	≤ 18	≤ 2																																																								
64 QAM	> 5	> 4	> 8	> 12	> 16	> 18	≤ 3																																																								
256 QAM	≥ 1						≤ 5																																																								
LTE A-MPR	In the base station simulator configuration, Network Setting value is set to NS_01 to disable A-MPR during SAR testing and the LTE SAR tests was transmitting on all TTI frames (Maximum TTI)																																																														
Spectrum plots for RB configuration	A properly configured base station simulator was used for the SAR and power measurement; therefore, spectrum plots for each RB allocation and offset configuration are not included in the SAR report.																																																														
Power reduction applied to satisfy SAR compliance	<p>Yes</p> <ol style="list-style-type: none"> <li>The device employs proximity sensors that detect the presence of the user's body at the front or back faces of the device. When front or back body worn condition is detected, LTE band 2/4/7/66 reduced power will be active. (P-sensor can't work at detecting presence of the user's body at the four edges of the device.)</li> <li>P-sensor can detect handheld state, LTE band 2/4/7/66 for front/back/bottom sides of product specific 10g SAR condition reduced powers will be active.</li> <li>When hotspot mode is enabled, power reduction will be activated to limit the maximum power of LTE band 2/4/7/66.</li> </ol>																																																														



Transmission (H, M, L) channel numbers and frequencies in each LTE band												
LTE Band 2												
	Bandwidth 1.4 MHz		Bandwidth 3 MHz		Bandwidth 5 MHz		Bandwidth 10 MHz		Bandwidth 15 MHz		Bandwidth 20 MHz	
	Ch. #	Freq. (MHz)	Ch. #	Freq. (MHz)	Ch. #	Freq. (MHz)	Ch. #	Freq. (MHz)	Ch. #	Freq. (MHz)	Ch. #	Freq. (MHz)
L	18607	1850.7	18615	1851.5	18625	1852.5	18650	1855	18675	1857.5	18700	1860
M	18900	1880	18900	1880	18900	1880	18900	1880	18900	1880	18900	1880
H	19193	1909.3	19185	1908.5	19175	1907.5	19150	1905	19125	1902.5	19100	1900
LTE Band 4												
	Bandwidth 1.4 MHz		Bandwidth 3 MHz		Bandwidth 5 MHz		Bandwidth 10 MHz		Bandwidth 15 MHz		Bandwidth 20 MHz	
	Ch. #	Freq. (MHz)	Ch. #	Freq. (MHz)	Ch. #	Freq. (MHz)	Ch. #	Freq. (MHz)	Ch. #	Freq. (MHz)	Ch. #	Freq. (MHz)
L	19957	1710.7	19965	1711.5	19975	1712.5	20000	1715	20025	1717.5	20050	1720
M	20175	1732.5	20175	1732.5	20175	1732.5	20175	1732.5	20175	1732.5	20175	1732.5
H	20393	1754.3	20385	1753.5	20375	1752.5	20350	1750	20325	1747.5	20300	1745
LTE Band 5												
	Bandwidth 1.4 MHz		Bandwidth 3 MHz		Bandwidth 5 MHz		Bandwidth 10 MHz		Bandwidth 15 MHz		Bandwidth 20 MHz	
	Ch. #	Freq. (MHz)	Ch. #	Freq. (MHz)	Ch. #	Freq. (MHz)	Ch. #	Freq. (MHz)	Ch. #	Freq. (MHz)	Ch. #	Freq. (MHz)
L	20407	824.7	20415	825.5	20425	826.5	20450	829	20450	829	20450	829
M	20525	836.5	20525	836.5	20525	836.5	20525	836.5	20525	836.5	20525	836.5
H	20643	848.3	20635	847.5	20625	846.5	20600	844	20600	844	20600	844
LTE Band 7												
	Bandwidth 5 MHz		Bandwidth 10 MHz		Bandwidth 15 MHz		Bandwidth 20 MHz		Bandwidth 15 MHz		Bandwidth 20 MHz	
	Ch. #	Freq. (MHz)	Ch. #	Freq. (MHz)	Ch. #	Freq. (MHz)	Ch. #	Freq. (MHz)	Ch. #	Freq. (MHz)	Ch. #	Freq. (MHz)
L	20775	2502.5	20800	2505	20825	2507.5	20850	2510	20850	2510	20850	2510
M	21100	2535	21100	2535	21100	2535	21100	2535	21100	2535	21100	2535
H	21425	2567.5	21400	2565	21375	2562.5	21350	2560	21350	2560	21350	2560
LTE Band 66												
	Bandwidth 1.4 MHz		Bandwidth 3 MHz		Bandwidth 5 MHz		Bandwidth 10 MHz		Bandwidth 15 MHz		Bandwidth 20 MHz	
	Ch. #	Freq. (MHz)	Ch. #	Freq. (MHz)	Ch. #	Freq. (MHz)	Ch. #	Freq. (MHz)	Ch. #	Freq. (MHz)	Ch. #	Freq. (MHz)
L	131979	1710.7	131987	1711.5	131997	1712.5	132022	1715	132047	1717.5	132072	1720
M	132322	1745	132322	1745	132322	1745	132322	1745	132322	1745	132322	1745
H	132665	1779.3	132657	1778.5	132647	1777.5	132622	1775	132597	1772.5	132572	1770



## 5. Proximity Sensor Triggering Test

### 5.1 Proximity sensor triggering distances(Per KDB616217§6.2)

1. Proximity sensor triggering distance testing was performed according to the procedures outlined in KDB 616217 D04 section 6.2, and EUT moving further away from the flat phantom and EUT moving toward the flat phantom were both assessed and the tissue-equivalent medium for highest frequency (2600MHz) and lowest (850MHz) frequency was used for proximity sensor triggering testing.
2. Capacitive proximity sensor placed coincident with antenna elements at the bottom end of the phone are utilized to determine when the device comes in proximity of the user's body at the front or back or bottom side surface of the device. There is no need to do sensor coverage testing for the proximity sensor is designed to support sufficient detection range and sensitivity to cover regions of the sensors in all applicable directions since the proximity sensor entirely covers the antenna.
3. When the proximity sensor is active, GSM850/1900, WCDMA band II/IV/V and LTE band 2/4/7/66 reduced power will be active for front/ back body worn SAR.
4. P-sensor can detect handheld state, WCDMA band II / IV, and LTE band 2/4/7/66 for front/back/ bottom sides of product specific 10g SAR condition reduced powers will be active for handheld SAR.
5. The proximity sensors used to detect the proximity of the user's body at the front, back, bottom side surface of the device use a detection threshold distance. The data shown in the sections below shows the distance(s).

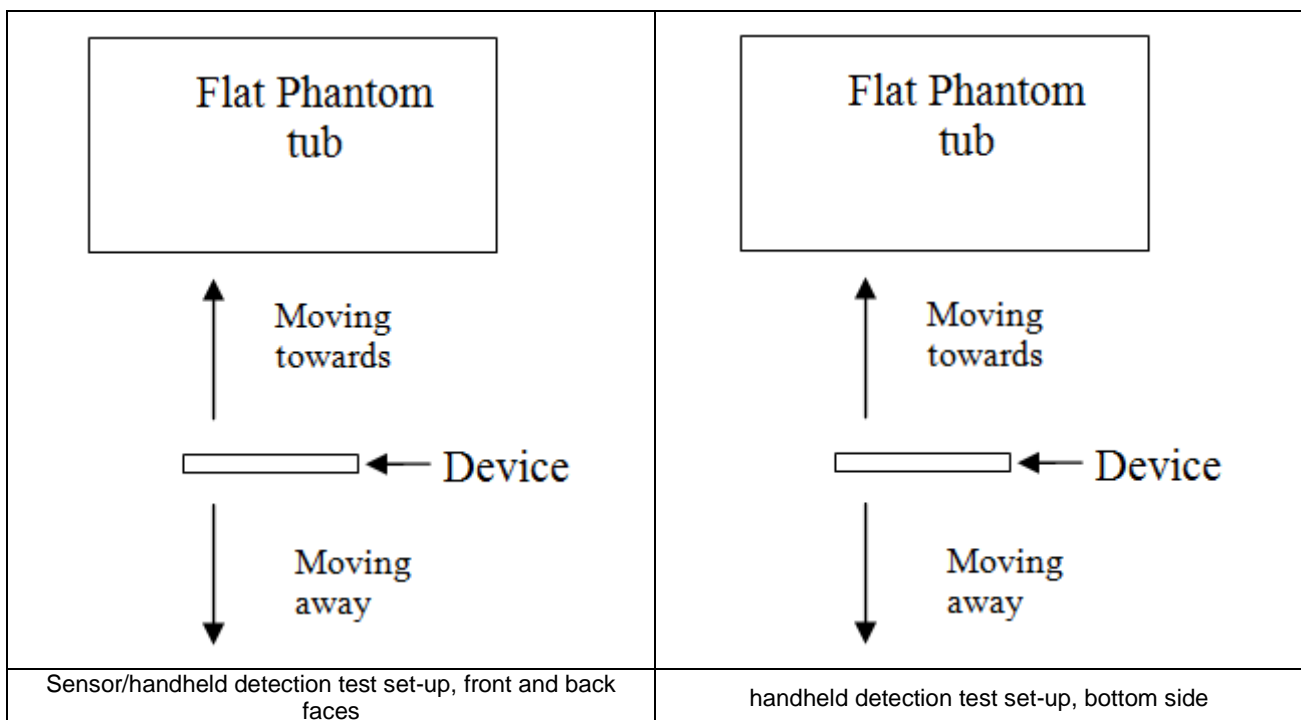

**<P-Sensor>**

Proximity Sensor Triggering Distance (mm)				
Position	Front		Back	
	Moving towards	Moving away	Moving towards	Moving away
Minimum	10	14	22	23

TX. Band	Proximity Sensor Triggering Power (dBm)		
	Full	Reduced	power reduction (dB)
	max. tune up limit (dBm)	max. tune up limit(dBm)	
GPRS850 2 Tx slots	31.5	30	1.5
GPRS1900 2 Tx slots	28.5	24	4.5
WCDMA Band II	24	16.5	7.5
WCDMA Band IV	24	15.5	8.5
WCDMA Band V	24	23	1
LTE Band2	24	16	8
LTE Band4	24	16	8
LTE Band7	24	19	5
LTE Band66	24	16	8



Proximity Sensor Triggering Distance (mm) and Triggering Power (dBm)																								
Front																								
Distance	50	48	45	42	39	36	33	30	27	24	21	18	15	14	13	12	11	10	9	8	7	6	3	0
GPRS850 2 Tx slots	31.5	31.5	31.5	31.5	31.5	31.5	31.5	31.5	31.5	31.5	31.5	31.5	31.5	31.5	31.5	31.5	31.5	30	30	30	30	30	30	30
GPRS1900 2 Tx slots	28.5	28.5	28.5	28.5	28.5	28.5	28.5	28.5	28.5	28.5	28.5	28.5	28.5	28.5	28.5	28.5	28.5	24	24	24	24	24	24	24
WCDMA Band II	24	24	24	24	24	24	24	24	24	24	24	24	24	24	24	24	24	16.5	16.5	16.5	16.5	16.5	16.5	16.5
WCDMA Band IV	24	24	24	24	24	24	24	24	24	24	24	24	24	24	24	24	24	15.5	15.5	15.5	15.5	15.5	15.5	15.5
WCDMA Band V	24	24	24	24	24	24	24	24	24	24	24	24	24	24	24	24	24	23	23	23	23	23	23	23
LTE Band2	24	24	24	24	24	24	24	24	24	24	24	24	24	24	24	24	24	16	16	16	16	16	16	16
LTE Band4	24	24	24	24	24	24	24	24	24	24	24	24	24	24	24	24	24	16	16	16	16	16	16	16
LTE Band7	24	24	24	24	24	24	24	24	24	24	24	24	24	24	24	24	24	19	19	19	19	19	19	19
LTE Band66	24	24	24	24	24	24	24	24	24	24	24	24	24	24	24	24	24	16	16	16	16	16	16	16

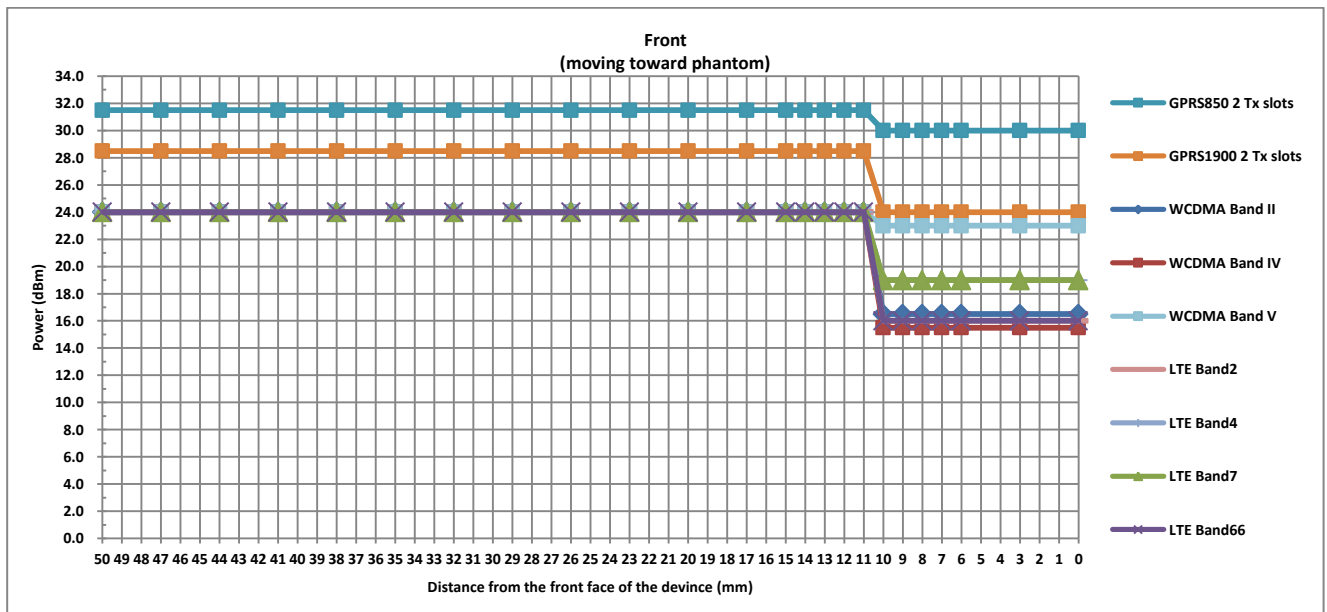



Proximity Sensor Triggering Distance (mm) and Triggering Power (dBm)																								
Front																								
Distance	50	47	43	40	37	34	31	28	25	22	19	18	17	16	15	14	13	12	11	10	7	4	1	0
GPRS850 2 Tx slots	31.5	31.5	31.5	31.5	31.5	31.5	31.5	31.5	31.5	31.5	31.5	31.5	31.5	31.5	31.5	30	30	30	30	30	30	30	30	30
GPRS1900 2 Tx slots	28.5	28.5	28.5	28.5	28.5	28.5	28.5	28.5	28.5	28.5	28.5	28.5	28.5	28.5	28.5	24	24	24	24	24	24	24	24	24
WCDMA Band II	24	24	24	24	24	24	24	24	24	24	24	24	24	24	24	16.5	16.5	16.5	16.5	16.5	16.5	16.5	16.5	16.5
WCDMA Band IV	24	24	24	24	24	24	24	24	24	24	24	24	24	24	24	15.5	15.5	15.5	15.5	15.5	15.5	15.5	15.5	15.5
WCDMA Band V	24	24	24	24	24	24	24	24	24	24	24	24	24	24	24	23	23	23	23	23	23	23	23	23
LTE Band2	24	24	24	24	24	24	24	24	24	24	24	24	24	24	24	16	16	16	16	16	16	16	16	16
LTE Band4	24	24	24	24	24	24	24	24	24	24	24	24	24	24	24	16	16	16	16	16	16	16	16	16
LTE Band7	24	24	24	24	24	24	24	24	24	24	24	24	24	24	24	19	19	19	19	19	19	19	19	19
LTE Band66	24	24	24	24	24	24	24	24	24	24	24	24	24	24	24	16	16	16	16	16	16	16	16	16

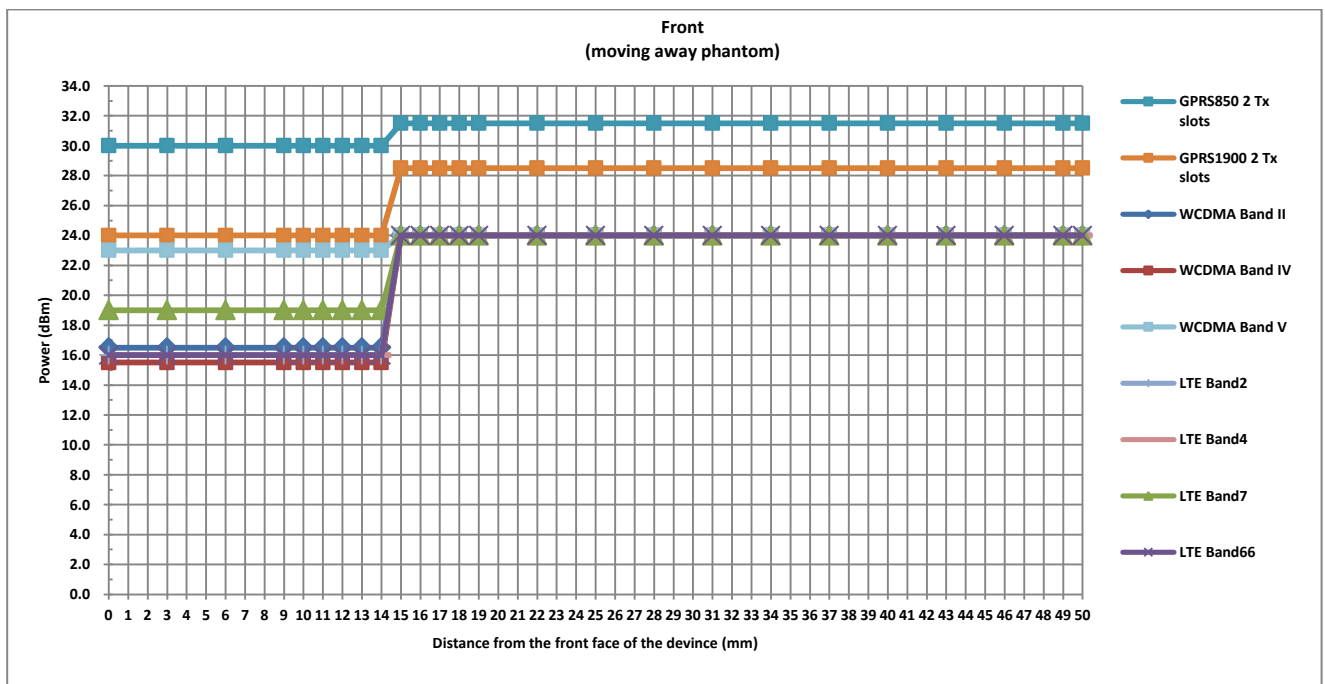

Proximity Sensor Triggering Distance (mm) and Triggering Power (dBm)

Back																								
Distance	50	48	45	42	39	36	33	30	27	26	25	24	23	22	21	20	19	18	15	12	9	6	3	0
GPRS850 2 Tx slots	31.5	31.5	31.5	31.5	31.5	31.5	31.5	31.5	31.5	31.5	31.5	31.5	31.5	30	30	30	30	30	30	30	30	30	30	30
GPRS1900 2 Tx slots	28.5	28.5	28.5	28.5	28.5	28.5	28.5	28.5	28.5	28.5	28.5	28.5	28.5	24	24	24	24	24	24	24	24	24	24	24
WCDMA Band II	24	24	24	24	24	24	24	24	24	24	24	24	24	16.5	16.5	16.5	16.5	16.5	16.5	16.5	16.5	16.5	16.5	16.5
WCDMA Band IV	24	24	24	24	24	24	24	24	24	24	24	24	24	15.5	15.5	15.5	15.5	15.5	15.5	15.5	15.5	15.5	15.5	15.5
WCDMA Band V	24	24	24	24	24	24	24	24	24	24	24	24	24	23	23	23	23	23	23	23	23	23	23	23
LTE Band2	24	24	24	24	24	24	24	24	24	24	24	24	24	16	16	16	16	16	16	16	16	16	16	16
LTE Band4	24	24	24	24	24	24	24	24	24	24	24	24	24	16	16	16	16	16	16	16	16	16	16	16
LTE Band7	24	24	24	24	24	24	24	24	24	24	24	24	24	19	19	19	19	19	19	19	19	19	19	19
LTE Band66	24	24	24	24	24	24	24	24	24	24	24	24	24	16	16	16	16	16	16	16	16	16	16	16

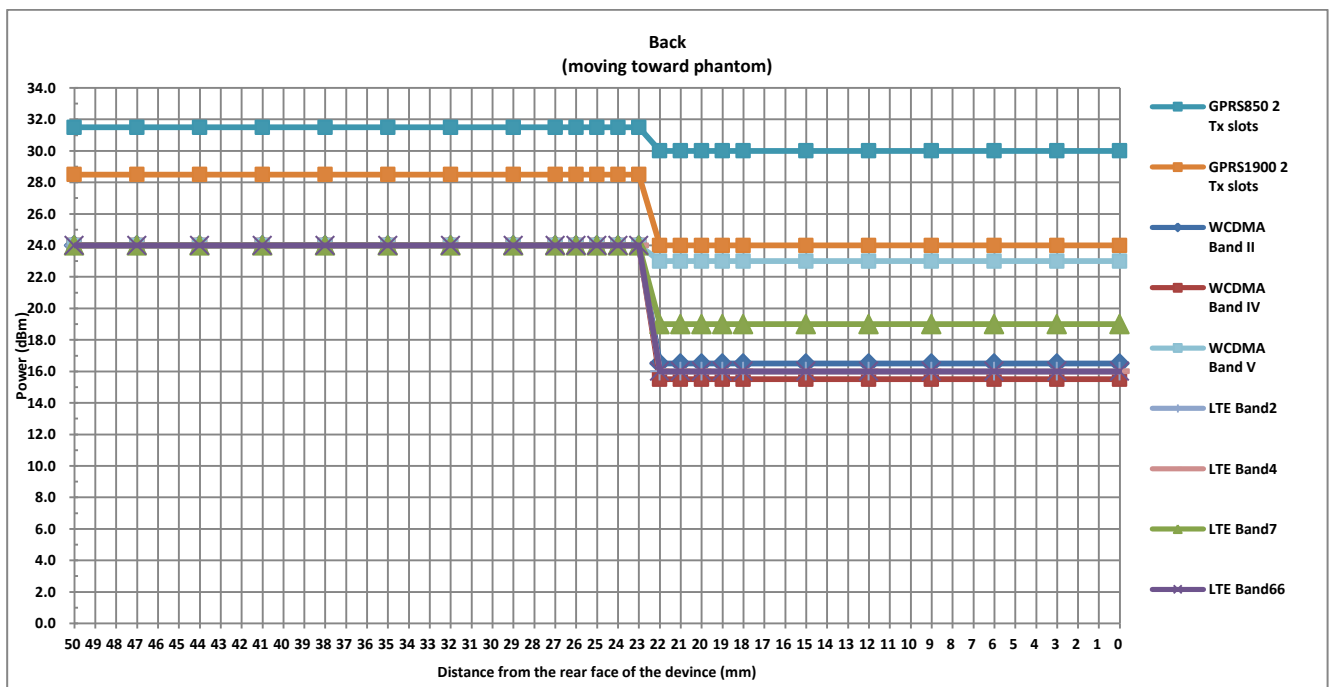



Proximity Sensor Triggering Distance (mm) and Triggering Power (dBm)

Back																									
Distance	50	49	46	43	40	37	34	31	28	27	26	25	24	23	22	21	20	19	16	13	10	7	4	1	0
GPRS850 2 Tx slots	31.5	31.5	31.5	31.5	31.5	31.5	31.5	31.5	31.5	31.5	31.5	31.5	31.5	30	30	30	30	30	30	30	30	30	30	30	30
GPRS1900 2 Tx slots	28.5	28.5	28.5	28.5	28.5	28.5	28.5	28.5	28.5	28.5	28.5	28.5	28.5	24	24	24	24	24	24	24	24	24	24	24	24
WCDMA Band II	24	24	24	24	24	24	24	24	24	24	24	24	24	16.5	16.5	16.5	16.5	16.5	16.5	16.5	16.5	16.5	16.5	16.5	16.5
WCDMA Band IV	24	24	24	24	24	24	24	24	24	24	24	24	24	15.5	15.5	15.5	15.5	15.5	15.5	15.5	15.5	15.5	15.5	15.5	15.5
WCDMA Band V	24	24	24	24	24	24	24	24	24	24	24	24	24	23	23	23	23	23	23	23	23	23	23	23	23
LTE Band2	24	24	24	24	24	24	24	24	24	24	24	24	24	16	16	16	16	16	16	16	16	16	16	16	16
LTE Band4	24	24	24	24	24	24	24	24	24	24	24	24	24	16	16	16	16	16	16	16	16	16	16	16	16
LTE Band7	24	24	24	24	24	24	24	24	24	24	24	24	24	19	19	19	19	19	19	19	19	19	19	19	19
LTE Band66	24	24	24	24	24	24	24	24	24	24	24	24	24	16	16	16	16	16	16	16	16	16	16	16	16

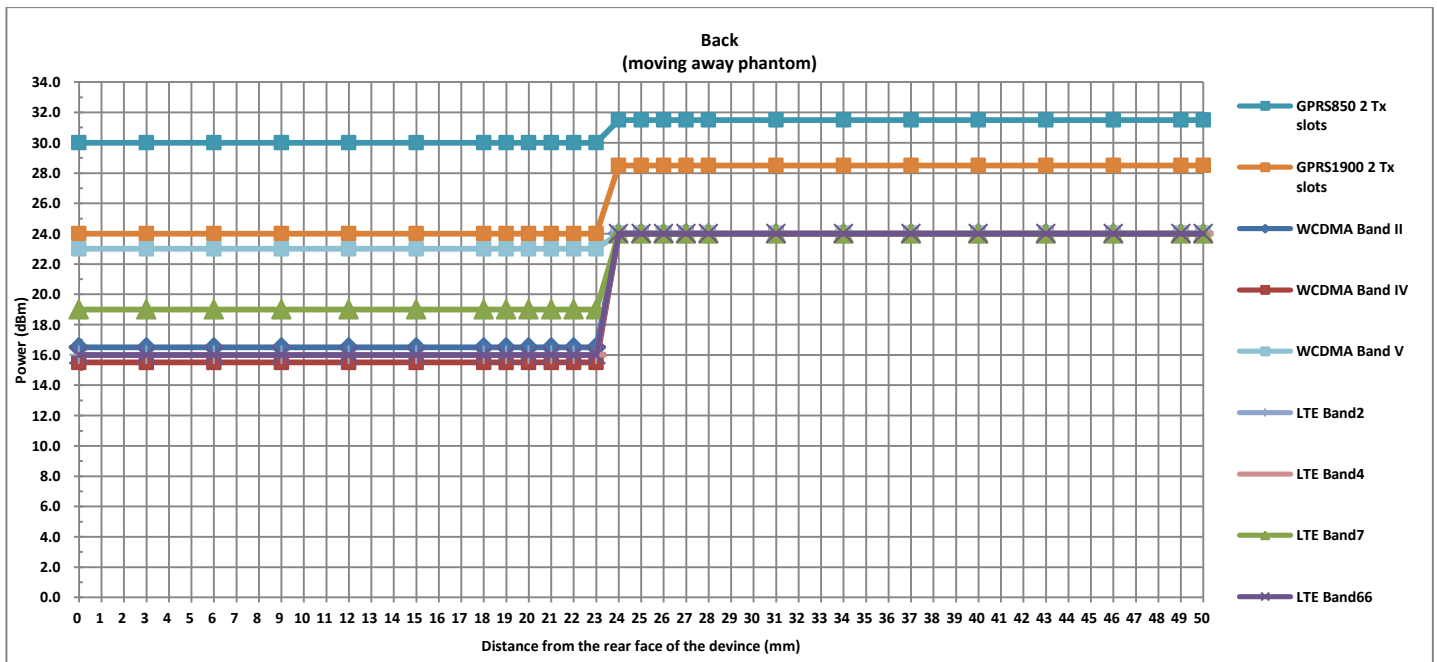

**<Handheld>**

Handheld Triggering Distance (mm)						
Position	Front		Back		Bottom Side	
	Moving towards	Moving away	Moving towards	Moving away	Moving towards	Moving away
Minimum	6	10	10	12	13	17

TX. Band	Handheld Triggering Power (dBm)		
	Full	Reduced	power reduction (dB)
	max. tune up limit (dBm)	max. tune up limit(dBm)	
WCDMA II	24	21.5	2.5
WCDMA IV	24	21	3
LTE Band2	24	21	3
LTE Band4	24	22	2
LTE Band7	24	21.5	2.5
LTE Band66	24	22	2



Handheld Triggering Distance (mm) and Triggering Power (dBm)																								
Front																								
Distance	50	47	44	41	38	35	32	29	26	23	20	17	14	11	10	9	8	7	6	5	4	3	2	0
WCDMA II	24	24	24	24	24	24	24	24	24	24	24	24	24	24	24	24	24	24	21.5	21.5	21.5	21.5	21.5	21.5
WCDMA IV	24	24	24	24	24	24	24	24	24	24	24	24	24	24	24	24	24	24	21	21	21	21	21	21
LTE Band2	24	24	24	24	24	24	24	24	24	24	24	24	24	24	24	24	24	24	21	21	21	21	21	21
LTE Band4	24	24	24	24	24	24	24	24	24	24	24	24	24	24	24	24	24	24	22	22	22	22	22	22
LTE Band7	24	24	24	24	24	24	24	24	24	24	24	24	24	24	24	24	24	24	21.5	21.5	21.5	21.5	21.5	21.5
LTE Band66	24	24	24	24	24	24	24	24	24	24	24	24	24	24	24	24	24	24	22	22	22	22	22	22

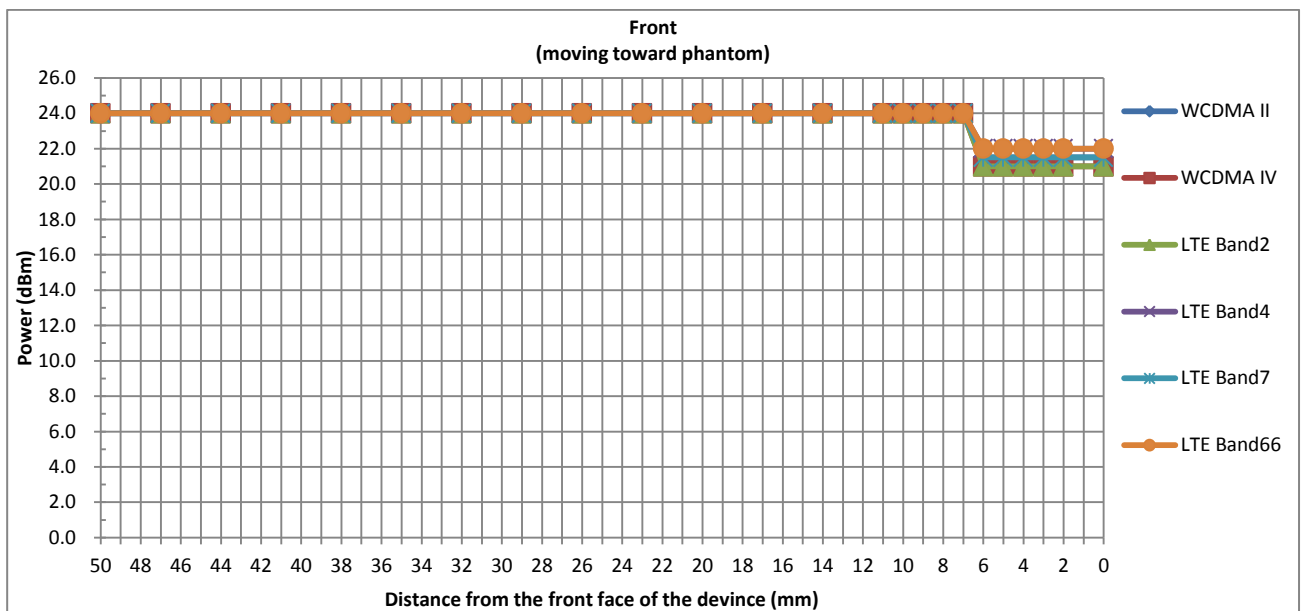





Handheld Triggering Distance (mm) and Triggering Power (dBm)

Front																									
Distance	50	49	46	43	40	37	34	31	28	25	22	19	16	13	12	11	10	9	10	9	8	7	6	3	0
WCDMA II	24	24	24	24	24	24	24	24	24	24	24	24	24	24	24	24	24	24	21.5	21.5	21.5	21.5	21.5	21.5	21.5
WCDMA IV	24	24	24	24	24	24	24	24	24	24	24	24	24	24	24	24	24	24	21	21	21	21	21	21	21
LTE Band2	24	24	24	24	24	24	24	24	24	24	24	24	24	24	24	24	24	24	21	21	21	21	21	21	21
LTE Band4	24	24	24	24	24	24	24	24	24	24	24	24	24	24	24	24	24	24	22	22	22	22	22	22	22
LTE Band7	24	24	24	24	24	24	24	24	24	24	24	24	24	24	24	24	24	24	21.5	21.5	21.5	21.5	21.5	21.5	21.5
LTE Band66	24	24	24	24	24	24	24	24	24	24	24	24	24	24	24	24	24	24	22	22	22	22	22	22	22

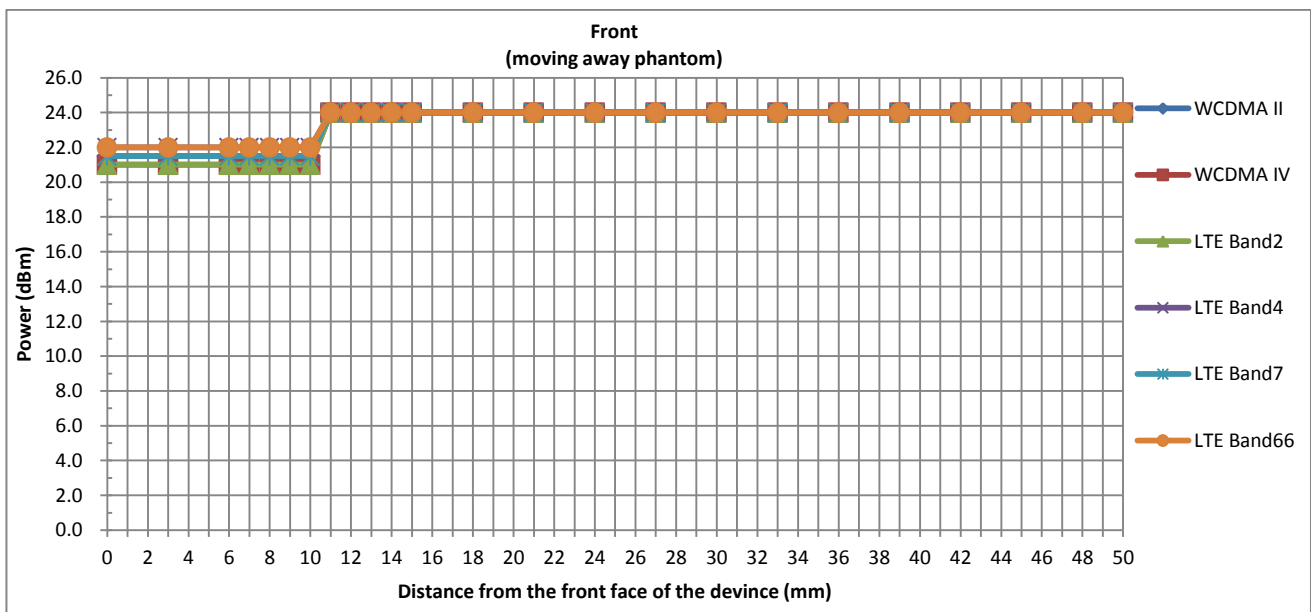

Handheld Triggering Distance (mm) and Triggering Power (dBm)																								
Back																								
Distance	50	48	45	42	39	36	33	30	27	24	21	18	15	14	13	12	11	10	9	8	7	6	3	0
WCDMA II	24	24	24	24	24	24	24	24	24	24	24	24	24	24	24	24	24	21.5	21.5	21.5	21.5	21.5	21.5	21.5
WCDMA IV	24	24	24	24	24	24	24	24	24	24	24	24	24	24	24	24	24	21	21	21	21	21	21	21
LTE Band2	24	24	24	24	24	24	24	24	24	24	24	24	24	24	24	24	24	21	21	21	21	21	21	21
LTE Band4	24	24	24	24	24	24	24	24	24	24	24	24	24	24	24	24	24	22	22	22	22	22	22	22
LTE Band7	24	24	24	24	24	24	24	24	24	24	24	24	24	24	24	24	24	21.5	21.5	21.5	21.5	21.5	21.5	21.5
LTE Band66	24	24	24	24	24	24	24	24	24	24	24	24	24	24	24	24	24	22	22	22	22	22	22	22

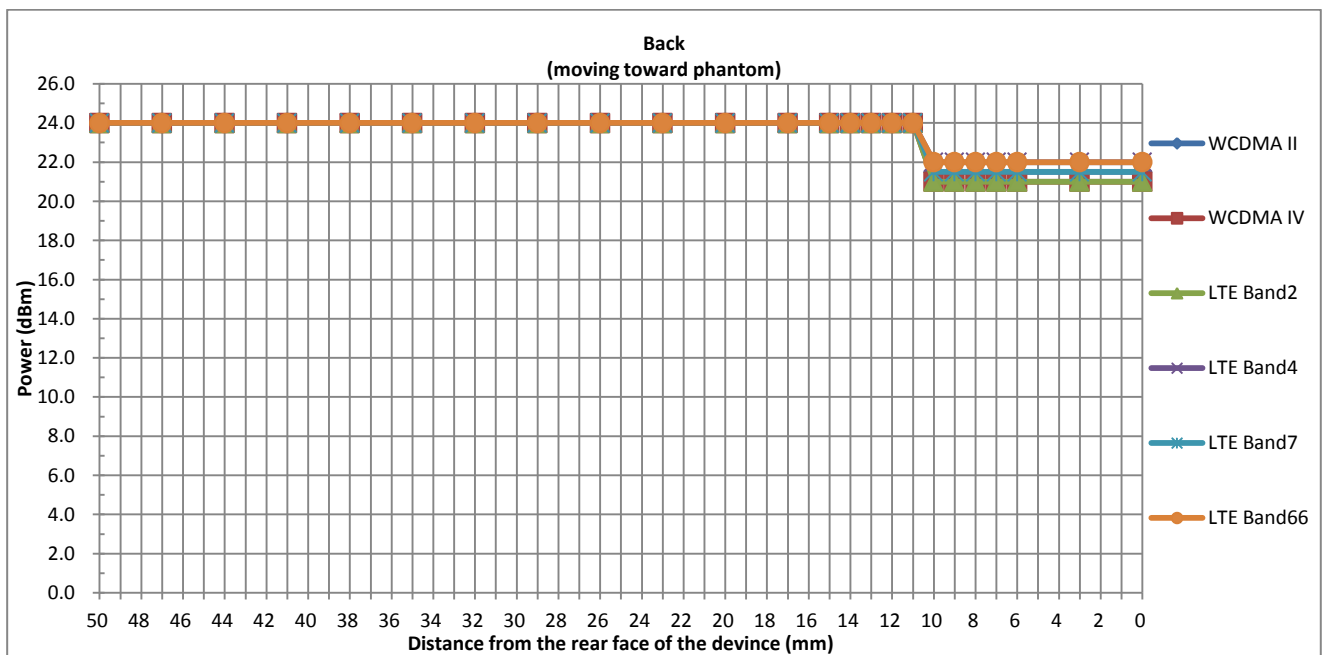

Handheld Triggering Distance (mm) and Triggering Power (dBm)																								
Back																								
Distance	50	47	44	41	38	35	32	29	26	23	20	17	16	15	14	13	12	11	10	9	8	5	2	0
WCDMA II	24	24	24	24	24	24	24	24	24	24	24	24	24	24	24	24	21.5	21.5	21.5	21.5	21.5	21.5	21.5	21.5
WCDMA IV	24	24	24	24	24	24	24	24	24	24	24	24	24	24	24	24	21	21	21	21	21	21	21	21
LTE Band2	24	24	24	24	24	24	24	24	24	24	24	24	24	24	24	24	21	21	21	21	21	21	21	21
LTE Band4	24	24	24	24	24	24	24	24	24	24	24	24	24	24	24	24	22	22	22	22	22	22	22	22
LTE Band7	24	24	24	24	24	24	24	24	24	24	24	24	24	24	24	24	21.5	21.5	21.5	21.5	21.5	21.5	21.5	21.5
LTE Band66	24	24	24	24	24	24	24	24	24	24	24	24	24	24	24	24	22	22	22	22	22	22	22	22

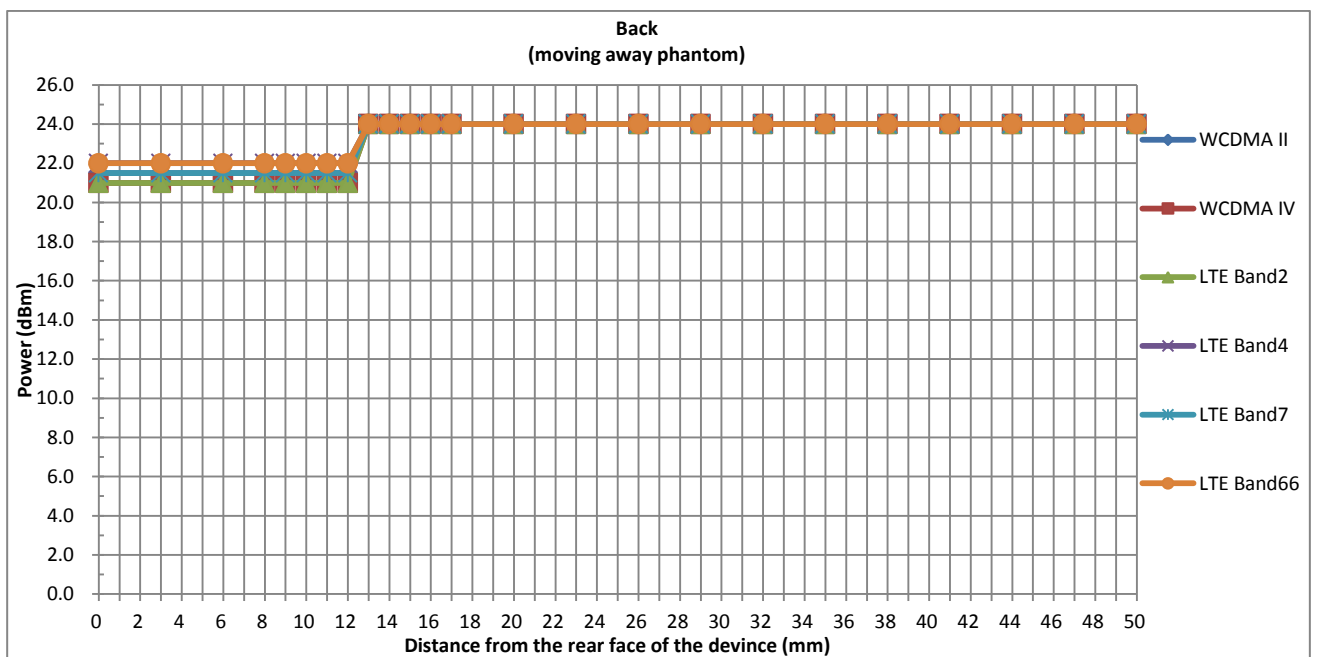



Handheld Triggering Distance (mm) and Triggering Power (dBm)																								
Bottom Side																								
Distance	50	48	45	42	39	36	33	30	27	24	21	18	17	16	15	14	13	12	11	10	9	6	3	0
WCDMA II	24	24	24	24	24	24	24	24	24	24	24	24	24	24	24	24	21.5	21.5	21.5	21.5	21.5	21.5	21.5	21.5
WCDMA IV	24	24	24	24	24	24	24	24	24	24	24	24	24	24	24	24	21	21	21	21	21	21	21	21
LTE Band2	24	24	24	24	24	24	24	24	24	24	24	24	24	24	24	24	21	21	21	21	21	21	21	21
LTE Band4	24	24	24	24	24	24	24	24	24	24	24	24	24	24	24	24	22	22	22	22	22	22	22	22
LTE Band7	24	24	24	24	24	24	24	24	24	24	24	24	24	24	24	24	21.5	21.5	21.5	21.5	21.5	21.5	21.5	21.5
LTE Band66	24	24	24	24	24	24	24	24	24	24	24	24	24	24	24	24	22	22	22	22	22	22	22	22

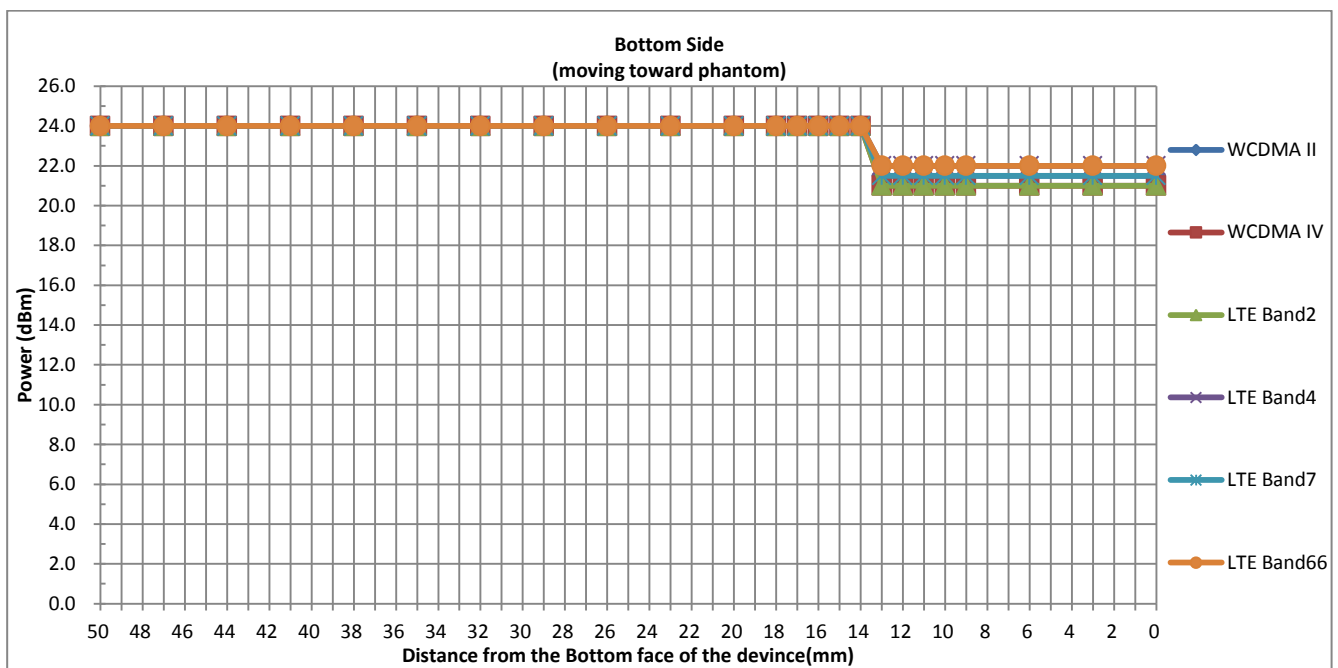

Handheld Triggering Distance (mm) and Triggering Power (dBm)																									
Bottom Side																									
Distance	50	49	46	43	40	37	34	31	28	25	22	21	20	19	18	17	16	15	14	13	10	7	4	1	0
WCDMA II	24	24	24	24	24	24	24	24	24	24	24	24	24	24	24	21.5	21.5	21.5	21.5	21.5	21.5	21.5	21.5	21.5	21.5
WCDMA IV	24	24	24	24	24	24	24	24	24	24	24	24	24	24	24	21	21	21	21	21	21	21	21	21	21
LTE Band2	24	24	24	24	24	24	24	24	24	24	24	24	24	24	24	21	21	21	21	21	21	21	21	21	21
LTE Band4	24	24	24	24	24	24	24	24	24	24	24	24	24	24	24	22	22	22	22	22	22	22	22	22	22
LTE Band7	24	24	24	24	24	24	24	24	24	24	24	24	24	24	24	21.5	21.5	21.5	21.5	21.5	21.5	21.5	21.5	21.5	21.5
LTE Band66	24	24	24	24	24	24	24	24	24	24	24	24	24	24	24	22	22	22	22	22	22	22	22	22	22

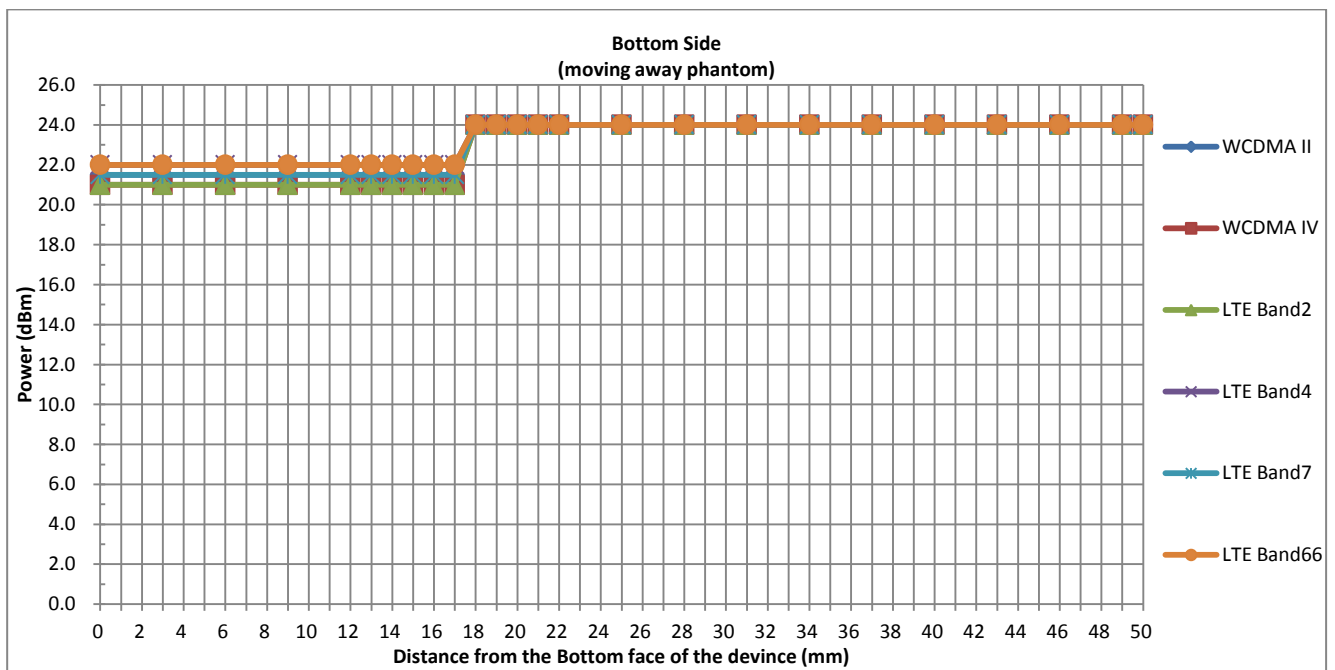

**6. RF Exposure Limits**

**6.1 Uncontrolled Environment**

Uncontrolled Environments are defined as locations where there is the exposure of individuals who have no knowledge or control of their exposure. The general population/uncontrolled exposure limits are applicable to situations in which the general public may be exposed or in which persons who are exposed as a consequence of their employment may not be made fully aware of the potential for exposure or cannot exercise control over their exposure. Members of the general public would come under this category when exposure is not employment-related; for example, in the case of a wireless transmitter that exposes persons in its vicinity.

**6.2 Controlled Environment**

Controlled Environments are defined as locations where there is exposure that may be incurred by persons who are aware of the potential for exposure, (i.e. as a result of employment or occupation). In general, occupational/controlled exposure limits are applicable to situations in which persons are exposed as a consequence of their employment, who have been made fully aware of the potential for exposure and can exercise control over their exposure. The exposure category is also applicable when the exposure is of a transient nature due to incidental passage through a location where the exposure levels may be higher than the general population/uncontrolled limits, but the exposed person is fully aware of the potential for exposure and can exercise control over his or her exposure by leaving the area or by some other appropriate means.

**Limits for Occupational/Controlled Exposure (W/kg)**

Whole-Body	Partial-Body	Hands, Wrists, Feet and Ankles
0.4	8.0	20.0

**Limits for General Population/Uncontrolled Exposure (W/kg)**

Whole-Body	Partial-Body	Hands, Wrists, Feet and Ankles
0.08	1.6	4.0

Whole-Body SAR is averaged over the entire body, partial-body SAR is averaged over any 1gram of tissue defined as a tissue volume in the shape of a cube. SAR for hands, wrists, feet and ankles is averaged over any 10 grams of tissue defined as a tissue volume in the shape of a cube.

## **7. Specific Absorption Rate (SAR)**

### **7.1 Introduction**

SAR is related to the rate at which energy is absorbed per unit mass in an object exposed to a radio field. The SAR distribution in a biological body is complicated and is usually carried out by experimental techniques or numerical modeling. The standard recommends limits for two tiers of groups, occupational/controlled and general population/uncontrolled, based on a person's awareness and ability to exercise control over his or her exposure. In general, occupational/controlled exposure limits are higher than the limits for general population/uncontrolled.

### **7.2 SAR Definition**

The SAR definition is the time derivative (rate) of the incremental energy (dW) absorbed by (dissipated in) an incremental mass (dm) contained in a volume element (dv) of a given density ( $\rho$ ). The equation description is as below:

$$\text{SAR} = \frac{d}{dt} \left( \frac{dW}{dm} \right) = \frac{d}{dt} \left( \frac{dW}{\rho dv} \right)$$

SAR is expressed in units of Watts per kilogram (W/kg)

$$\text{SAR} = \frac{\sigma |E|^2}{\rho}$$

Where:  $\sigma$  is the conductivity of the tissue,  $\rho$  is the mass density of the tissue and E is the RMS electrical field strength.

## 8. System Description and Setup

The DASY system used for performing compliance tests consists of the following items:

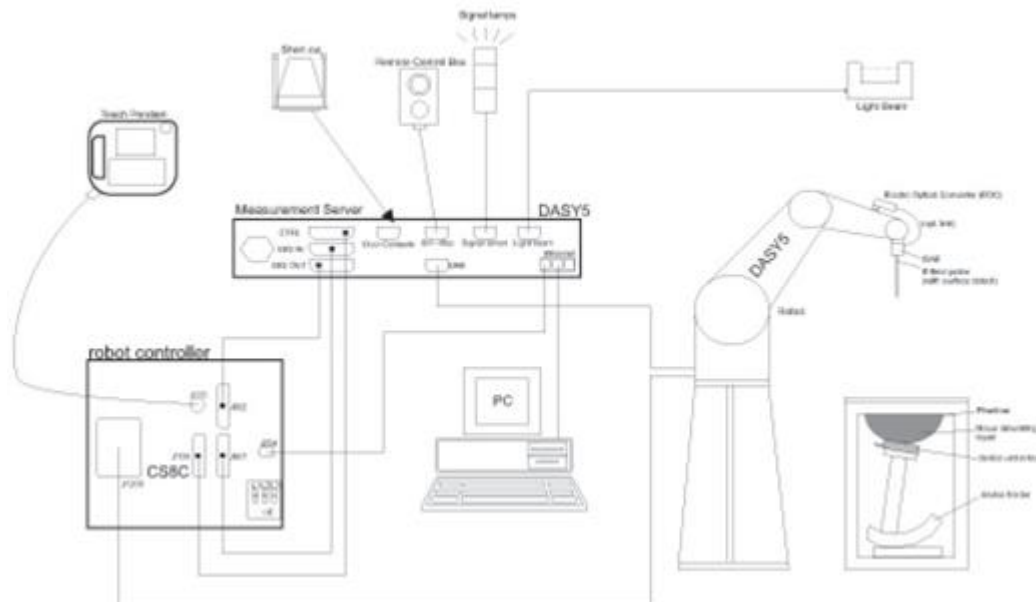

- A standard high precision 6-axis robot with controller, teach pendant and software. An arm extension for accommodating the data acquisition electronics (DAE).
- An isotropic Field probe optimized and calibrated for the targeted measurement.
- A data acquisition electronics (DAE) which performs the signal amplification, signal multiplexing, AD-conversion, offset measurements, mechanical surface detection, collision detection, etc. The unit is battery powered with standard or rechargeable batteries. The signal is optically transmitted to the EOC.
- The Electro-optical converter (EOC) performs the conversion from optical to electrical signals for the digital communication to the DAE. To use optical surface detection, a special version of the EOC is required. The EOC signal is transmitted to the measurement server.
- The function of the measurement server is to perform the time critical tasks such as signal filtering, control of the robot operation and fast movement interrupts.
- The Light Beam used is for probe alignment. This improves the (absolute) accuracy of the probe positioning.
- A computer running WinXP or Win7 and the DASY5 software.
- Remote control and teach pendant as well as additional circuitry for robot safety such as warning lamps, etc.
- The phantom, the device holder and other accessories according to the targeted measurement.



**8.1 E-Field Probe**

The SAR measurement is conducted with the dosimetric probe (manufactured by SPEAG).The probe is specially designed and calibrated for use in liquid with high permittivity. The dosimetric probe has special calibration in liquid at different frequency. This probe has a built in optical surface detection system to prevent from collision with phantom.

**<EX3DV4 Probe>**

<b>Construction</b>	Symmetric design with triangular core Built-in shielding against static charges PEEK enclosure material (resistant to organic solvents, e.g., DGBE)	
<b>Frequency</b>	10 MHz – >6 GHz Linearity: ±0.2 dB (30 MHz – 6 GHz)	
<b>Directivity</b>	±0.3 dB in TSL (rotation around probe axis) ±0.5 dB in TSL (rotation normal to probe axis)	
<b>Dynamic Range</b>	10 µW/g – >100 mW/g Linearity: ±0.2 dB (noise: typically <1 µW/g)	
<b>Dimensions</b>	Overall length: 337 mm (tip: 20 mm) Tip diameter: 2.5 mm (body: 12 mm) Typical distance from probe tip to dipole centers: 1 mm	

**8.2 Data Acquisition Electronics (DAE)**

The data acquisition electronics (DAE) consists of a highly sensitive electrometer-grade preamplifier with auto-zeroing, a channel and gain-switching multiplexer, a fast 16 bit AD-converter and a command decoder and control logic unit. Transmission to the measurement server is accomplished through an optical downlink for data and status information as well as an optical uplink for commands and the clock.

The input impedance of the DAE is 200 MOhm; the inputs are symmetrical and floating. Common mode rejection is above 80 dB.



**Photo of DAE**

**8.3 Phantom**

**<SAM Twin Phantom>**

<b>Shell Thickness</b>	2 ± 0.2 mm; Center ear point: 6 ± 0.2 mm	
<b>Filling Volume</b>	Approx. 25 liters	
<b>Dimensions</b>	Length: 1000 mm; Width: 500 mm; Height: adjustable feet	
<b>Measurement Areas</b>	Left Hand, Right Hand, Flat Phantom	

The bottom plate contains three pair of bolts for locking the device holder. The device holder positions are adjusted to the standard measurement positions in the three sections. A white cover is provided to tap the phantom during off-periods to prevent water evaporation and changes in the liquid parameters. On the phantom top, three reference markers are provided to identify the phantom position with respect to the robot.

**<ELI Phantom>**

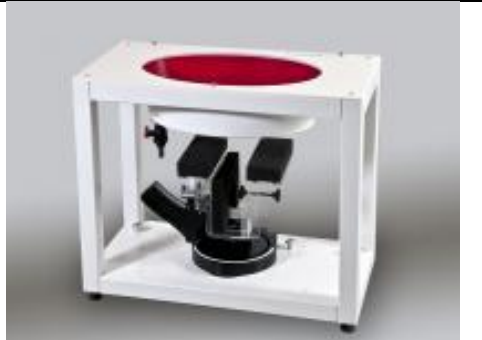
<b>Shell Thickness</b>	2 ± 0.2 mm (sagging: <1%)	
<b>Filling Volume</b>	Approx. 30 liters	
<b>Dimensions</b>	Major ellipse axis: 600 mm Minor axis: 400 mm	

The ELI phantom is intended for compliance testing of handheld and body-mounted wireless devices in the frequency range of 30 MHz to 6 GHz. ELI4 is fully compatible with standard and all known tissue simulating liquids.

## 8.4 Device Holder

### <Mounting Device for Hand-Held Transmitter>

In combination with the Twin SAM V5.0/V5.0c or ELI phantoms, the Mounting Device for Hand-Held Transmitters enables rotation of the mounted transmitter device to specified spherical coordinates. At the heads, the rotation axis is at the ear opening. Transmitter devices can be easily and accurately positioned according to IEC 62209-1, IEEE 1528, FCC, or other specifications. The device holder can be locked for positioning at different phantom sections (left head, right head, flat). And upgrade kit to Mounting Device to enable easy mounting of wider devices like big smart-phones, e-books, small tablets, etc. It holds devices with width up to 140 mm.



Mounting Device for Hand-Held Transmitters



Mounting Device Adaptor for Wide-Phones

### <Mounting Device for Laptops and other Body-Worn Transmitters>

The extension is lightweight and made of POM, acrylic glass and foam. It fits easily on the upper part of the mounting device in place of the phone positioned. The extension is fully compatible with the SAM Twin and ELI phantoms.



Mounting Device for Laptops

## 9. Measurement Procedures

The measurement procedures are as follows:

### <Conducted power measurement>

- (a) For WWAN power measurement, use base station simulator to configure EUT WWAN transmission in conducted connection with RF cable, at maximum power in each supported wireless interface and frequency band.
- (b) Read the WWAN RF power level from the base station simulator.
- (c) For WLAN/BT power measurement, use engineering software to configure EUT WLAN/BT continuously transmission, at maximum RF power in each supported wireless interface and frequency band
- (d) Connect EUT RF port through RF cable to the power meter, and measure WLAN/BT output power

### <SAR measurement>

- (a) Use base station simulator to configure EUT WWAN transmission in radiated connection, and engineering software to configure EUT WLAN/BT continuously transmission, at maximum RF power, in the highest power channel.
- (b) Place the EUT in the positions as Appendix D demonstrates.
- (c) Set scan area, grid size and other setting on the DASY software.
- (d) Measure SAR results for the highest power channel on each testing position.
- (e) Find out the largest SAR result on these testing positions of each band
- (f) Measure SAR results for other channels in worst SAR testing position if the reported SAR of highest power channel is larger than 0.8 W/kg

According to the test standard, the recommended procedure for assessing the peak spatial-average SAR value consists of the following steps:

- (a) Power reference measurement
- (b) Area scan
- (c) Zoom scan
- (d) Power drift measurement

### 9.1 Spatial Peak SAR Evaluation

The procedure for spatial peak SAR evaluation has been implemented according to the test standard. It can be conducted for 1g and 10g, as well as for user-specific masses. The DASY software includes all numerical procedures necessary to evaluate the spatial peak SAR value.

The base for the evaluation is a "cube" measurement. The measured volume must include the 1g and 10g cubes with the highest averaged SAR values. For that purpose, the center of the measured volume is aligned to the interpolated peak SAR value of a previously performed area scan.

The entire evaluation of the spatial peak values is performed within the post-processing engine (SEMCAD). The system always gives the maximum values for the 1g and 10g cubes. The algorithm to find the cube with highest averaged SAR is divided into the following stages:

- (a) Extraction of the measured data (grid and values) from the Zoom Scan
- (b) Calculation of the SAR value at every measurement point based on all stored data (A/D values and measurement parameters)
- (c) Generation of a high-resolution mesh within the measured volume
- (d) Interpolation of all measured values from the measurement grid to the high-resolution grid
- (e) Extrapolation of the entire 3-D field distribution to the phantom surface over the distance from sensor to surface
- (f) Calculation of the averaged SAR within masses of 1g and 10g

**9.2 Power Reference Measurement**

The Power Reference Measurement and Power Drift Measurements are for monitoring the power drift of the device under test in the batch process. The minimum distance of probe sensors to surface determines the closest measurement point to phantom surface. This distance cannot be smaller than the distance of sensor calibration points to probe tip as defined in the probe properties.

**9.3 Area Scan**

The area scan is used as a fast scan in two dimensions to find the area of high field values, before doing a fine measurement around the hot spot. The sophisticated interpolation routines implemented in DASY software can find the maximum found in the scanned area, within a range of the global maximum. The range (in dB0 is specified in the standards for compliance testing. For example, a 2 dB range is required in IEEE standard 1528 and IEC 62209 standards, whereby 3 dB is a requirement when compliance is assessed in accordance with the ARIB standard (Japan), if only one zoom scan follows the area scan, then only the absolute maximum will be taken as reference. For cases where multiple maximums are detected, the number of zoom scans has to be increased accordingly.

Area scan parameters extracted from FCC KDB 865664 D01v01r04 SAR measurement 100 MHz to 6 GHz.

	$\leq 3$ GHz	$> 3$ GHz
Maximum distance from closest measurement point (geometric center of probe sensors) to phantom surface	$5 \pm 1$ mm	$\frac{1}{2} \cdot \delta \cdot \ln(2) \pm 0.5$ mm
Maximum probe angle from probe axis to phantom surface normal at the measurement location	$30^\circ \pm 1^\circ$	$20^\circ \pm 1^\circ$
Maximum area scan spatial resolution: $\Delta x_{Area}, \Delta y_{Area}$	$\leq 2$ GHz: $\leq 15$ mm $2 - 3$ GHz: $\leq 12$ mm	$3 - 4$ GHz: $\leq 12$ mm $4 - 6$ GHz: $\leq 10$ mm
	When the x or y dimension of the test device, in the measurement plane orientation, is smaller than the above, the measurement resolution must be $\leq$ the corresponding x or y dimension of the test device with at least one measurement point on the test device.	

### 9.4 Zoom Scan

Zoom scans are used to assess the peak spatial SAR values within a cubic averaging volume containing 1 gram and 10 gram of simulated tissue. The zoom scan measures points (refer to table below) within a cube whose base faces are centered on the maxima found in a preceding area scan job within the same procedure. When the measurement is done, the zoom scan evaluates the averaged SAR for 1 gram and 10 gram and displays these values next to the job's label.

Zoom scan parameters extracted from FCC KDB 865664 D01v01r04 SAR measurement 100 MHz to 6 GHz.

		≤ 3 GHz	> 3 GHz	
Maximum zoom scan spatial resolution: $\Delta x_{Zoom}$ , $\Delta y_{Zoom}$		$\leq 2$ GHz: $\leq 8$ mm 2 – 3 GHz: $\leq 5$ mm*	3 – 4 GHz: $\leq 5$ mm* 4 – 6 GHz: $\leq 4$ mm*	
Maximum zoom scan spatial resolution, normal to phantom surface	uniform grid: $\Delta z_{Zoom}(n)$	$\leq 5$ mm	3 – 4 GHz: $\leq 4$ mm 4 – 5 GHz: $\leq 3$ mm 5 – 6 GHz: $\leq 2$ mm	
	graded grid	$\Delta z_{Zoom}(1)$ : between 1 <sup>st</sup> two points closest to phantom surface	$\leq 4$ mm	3 – 4 GHz: $\leq 3$ mm 4 – 5 GHz: $\leq 2.5$ mm 5 – 6 GHz: $\leq 2$ mm
		$\Delta z_{Zoom}(n>1)$ : between subsequent points	$\leq 1.5 \cdot \Delta z_{Zoom}(n-1)$	
Minimum zoom scan volume	x, y, z	$\geq 30$ mm	3 – 4 GHz: $\geq 28$ mm 4 – 5 GHz: $\geq 25$ mm 5 – 6 GHz: $\geq 22$ mm	
Note: $\delta$ is the penetration depth of a plane-wave at normal incidence to the tissue medium; see draft standard IEEE P1528-2011 for details. * When zoom scan is required and the <i>reported</i> SAR from the <i>area scan based 1-g SAR estimation</i> procedures of KDB 447498 is $\leq 1.4$ W/kg, $\leq 8$ mm, $\leq 7$ mm and $\leq 5$ mm zoom scan resolution may be applied, respectively, for 2 GHz to 3 GHz, 3 GHz to 4 GHz and 4 GHz to 6 GHz.				

### 9.5 Volume Scan Procedures

The volume scan is used to assess overlapping SAR distributions for antennas transmitting in different frequency bands. It is equivalent to an oversized zoom scan used in standalone measurements. The measurement volume will be used to enclose all the simultaneous transmitting antennas. For antennas transmitting simultaneously in different frequency bands, the volume scan is measured separately in each frequency band. In order to sum correctly to compute the 1g aggregate SAR, the EUT remain in the same test position for all measurements and all volume scan use the same spatial resolution and grid spacing. When all volume scan were completed, the software, SEMCAD postprocessor can combine and subsequently superpose these measurement data to calculating the multiband SAR.

### 9.6 Power Drift Monitoring

All SAR testing is under the EUT install full charged battery and transmit maximum output power. In DASy measurement software, the power reference measurement and power drift measurement procedures are used for monitoring the power drift of EUT during SAR test. Both these procedures measure the field at a specified reference position before and after the SAR testing. The software will calculate the field difference in dB. If the power drifts more than 5%, the SAR will be retested.



### 10. Test Equipment List

Manufacturer	Name of Equipment	Type/Model	Serial Number	Calibration	
				Last Cal.	Due Date
SPEAG	835MHz System Validation Kit	D835V2	4d151	2019/3/27	2020/3/26
SPEAG	1750MHz System Validation Kit	D1750V2	1090	2019/3/27	2020/3/26
SPEAG	1900MHz System Validation Kit	D1900V2	5d170	2019/3/26	2020/3/25
SPEAG	2450MHz System Validation Kit	D2450V2	908	2019/3/25	2020/3/24
SPEAG	2600MHz System Validation Kit	D2600V2	1061	2018/12/7	2019/12/6
SPEAG	Data Acquisition Electronics	DAE4	690	2019/1/23	2020/1/22
SPEAG	Dosimetric E-Field Probe	EX3DV4	3935	2018/11/26	2019/11/25
SPEAG	SAM Twin Phantom	QD 000 P40 CB	TP-1753	NCR	NCR
SPEAG	SAM Twin Phantom	QD 000 P40 CB	TP-1754	NCR	NCR
SPEAG	Phone Positioner	N/A	N/A	NCR	NCR
Anritsu	Radio Communication Analyzer	MT8821C	6201432831	2019/4/17	2020/4/16
Agilent	Wireless Communication Test Set	E5515C	MY52102706	2019/4/17	2020/4/16
Agilent	ENA Series Network Analyzer	E5071C	MY46111157	2019/4/17	2020/4/16
SPEAG	Dielectric Probe Kit	DAK-3.5	1071	2019/10/28	2020/10/27
Anritsu	Vector Signal Generator	MG3710A	6201682672	2019/1/14	2020/1/13
Rohde & Schwarz	Power Meter	NRVD	102081	2019/8/15	2020/8/14
Rohde & Schwarz	Power Sensor	NRV-Z5	100538	2019/8/14	2020/8/13
Rohde & Schwarz	Power Sensor	NRV-Z5	100539	2019/8/14	2020/8/13
R&S	CBT BLUETOOTH TESTER	CBT	101641	2019/1/14	2020/1/13
EXA	Spectrum Analyzer	FSV7	101631	2019/1/14	2020/1/13
Testo	Hygrometer	608-H1	1241332088	2019/1/11	2020/1/10
FLUKE	DIGITAC THERMOMETER	51II	97240029	2019/8/15	2020/8/14
ARRA	Power Divider	A3200-2	N/A	Note	
MCL	Attenuation1	BW-S10W5+	N/A	Note	
MCL	Attenuation2	BW-S10W5+	N/A	Note	
MCL	Attenuation3	BW-S10W5+	N/A	Note	
Agilent	Dual Directional Coupler	778D	20500	Note	
Agilent	Dual Directional Coupler	11691D	MY48151020	Note	
BONN	POWER AMPLIFIER	BLMA 0830-3	087193A	Note	
BONN	POWER AMPLIFIER	BLMA 2060-2	087193B	Note	

**Note:** Prior to system verification and validation, the path loss from the signal generator to the system check source and the power meter, which includes the amplifier, cable, attenuator and directional coupler, was measured by the network analyzer. The reading of the power meter was offset by the path loss difference between the path to the power meter and the path to the system check source to monitor the actual power level fed to the system check

## 11. System Verification

### 11.1 Tissue Simulating Liquids

For the measurement of the field distribution inside the SAM phantom with DASY, the phantom must be filled with around 25 liters of homogeneous body tissue simulating liquid. For head SAR testing, the liquid height from the ear reference point (ERP) of the phantom to the liquid top surface is larger than 15 cm, which is shown in Fig. 11.1. For body SAR testing, the liquid height from the center of the flat phantom to the liquid top surface is larger than 15 cm, which is shown in Fig. 11.2.

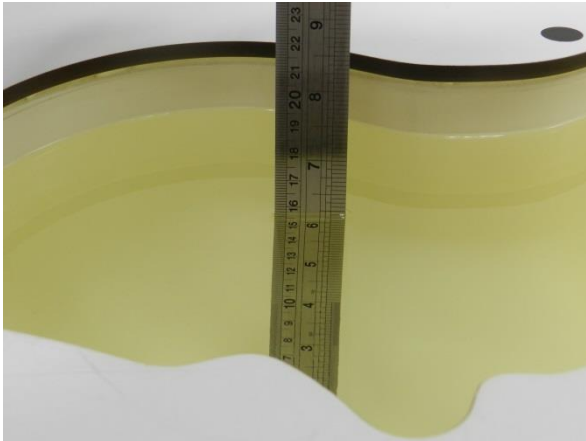

Fig 11.1 Photo of Liquid Height for Head SAR

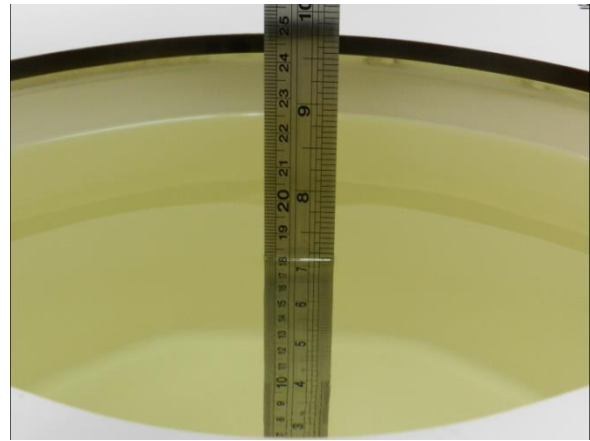

Fig 11.2 Photo of Liquid Height for Body SAR



**11.2 Tissue Verification**

The following tissue formulations are provided for reference only as some of the parameters have not been thoroughly verified. The composition of ingredients may be modified accordingly to achieve the desired target tissue parameters required for routine SAR evaluation.

Frequency (MHz)	Water (%)	Sugar (%)	Cellulose (%)	Salt (%)	Preventol (%)	DGBE (%)	Conductivity (σ)	Permittivity (ε <sub>r</sub> )
For Head								
835	40.3	57.9	0.2	1.4	0.2	0	0.90	41.5
1800, 1900, 2000	55.2	0	0	0.3	0	44.5	1.40	40.0
2450	55.0	0	0	0	0	45.0	1.80	39.2
2600	54.8	0	0	0.1	0	45.1	1.96	39.0

**<Tissue Dielectric Parameter Check Results>**

Frequency (MHz)	Tissue Type	Liquid Temp. (°C)	Conductivity (σ)	Permittivity (ε <sub>r</sub> )	Conductivity Target (σ)	Permittivity Target (ε <sub>r</sub> )	Delta (σ) (%)	Delta (ε <sub>r</sub> ) (%)	Limit (%)	Date
835	Head	22.7	0.929	42.225	0.90	41.50	3.22	1.75	±5	2019/11/12
1750	Head	22.9	1.382	39.700	1.37	40.10	0.88	-1.00	±5	2019/11/13
1900	Head	22.7	1.349	41.433	1.40	40.00	-3.64	3.58	±5	2019/11/16
2450	Head	22.6	1.808	38.325	1.80	39.20	0.44	-2.23	±5	2019/11/20
2600	Head	22.9	2.039	39.681	1.96	39.00	4.03	1.75	±5	2019/11/21

### 11.3 System Performance Check Results

Comparing to the original SAR value provided by SPEAG, the verification data should be within its specification of 10 %. Below table shows the target SAR and measured SAR after normalized to 1W input power. The table below indicates the system performance check can meet the variation criterion and the plots can be referred to Appendix A of this report.

**<1g SAR>**

Date	Frequency (MHz)	Tissue Type	Input Power (mW)	Dipole S/N	Probe S/N	DAE S/N	Measured 1g SAR (W/kg)	Targeted 1g SAR (W/kg)	Normalized 1g SAR (W/kg)	Deviation (%)
2019/11/12	835	Head	250	4d151	3935	690	2.46	9.30	9.84	5.81
2019/11/13	1750	Head	250	1090	3935	690	9.34	36.40	37.36	2.64
2019/11/16	1900	Head	250	5d170	3935	690	9.55	39.00	38.2	-2.05
2019/11/20	2450	Head	250	908	3935	690	12.60	52.80	50.4	-4.55
2019/11/21	2600	Head	250	1061	3935	690	14.10	57.70	56.4	-2.25

**<10g SAR>**

Date	Frequency (MHz)	Tissue Type	Input Power (mW)	Dipole S/N	Probe S/N	DAE S/N	Measured 10g SAR (W/kg)	Targeted 10g SAR (W/kg)	Normalized 10g SAR (W/kg)	Deviation (%)
2019/11/12	835	Head	250	4d151	3935	690	1.61	6.16	6.44	4.55
2019/11/13	1750	Head	250	1090	3935	690	5.08	19.20	20.32	5.83
2019/11/16	1900	Head	250	5d170	3935	690	4.98	20.30	19.92	-1.87
2019/11/21	2600	Head	250	1061	3935	690	6.22	25.90	24.88	-3.94

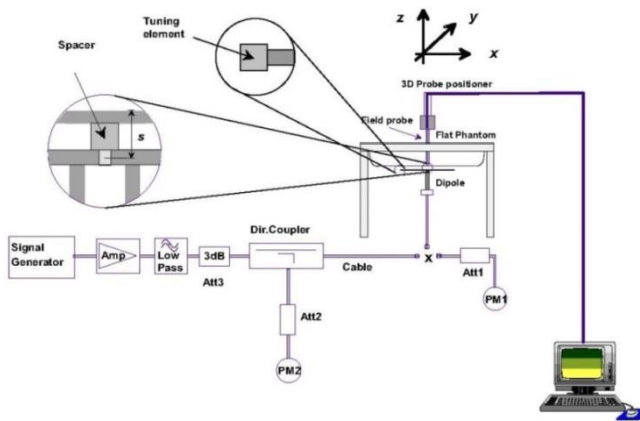

Fig 11.3.1 System Performance Check Setup



Fig 11.3.2 Setup Photo

## 12. RF Exposure Positions

### 12.1 Ear and handset reference point

Figure 12.1.1 shows the front, back, and side views of the SAM phantom. The center-of-mouth reference point is labeled “M,” the left ear reference point (ERP) is marked “LE,” and the right ERP is marked “RE.” Each ERP is 15 mm along the B-M (back-mouth) line behind the entrance-to-ear-canal (EEC) point, as shown in Figure 12.1.2 The Reference Plane is defined as passing through the two ear reference points and point M. The line N-F (neck-front), also called the reference pivoting line, is normal to the Reference Plane and perpendicular to both a line passing through RE and LE and the B-M line (see Figure 12.1.3). Both N-F and B-M lines should be marked on the exterior of the phantom shell to facilitate handset positioning. Posterior to the N-F line the ear shape is a flat surface with 6 mm thickness at each ERP, and forward of the N-F line the ear is truncated, as illustrated in Figure 12.1.2. The ear truncation is introduced to preclude the ear lobe from interfering with handset tilt, which could lead to unstable positioning at the cheek.

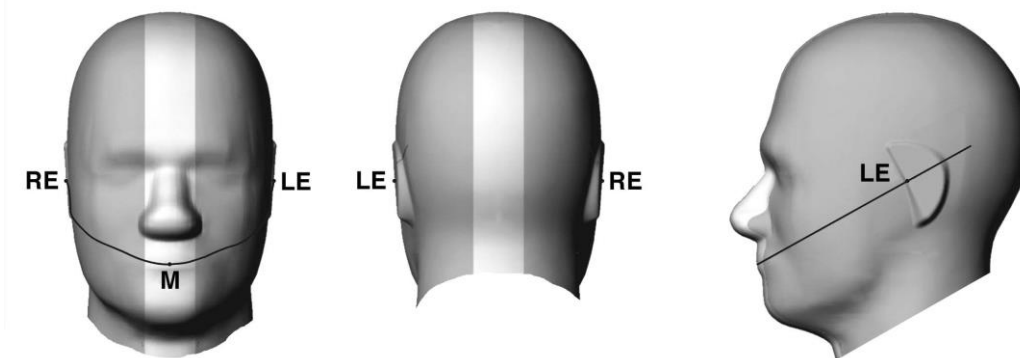

Fig 12.1.1 Front, back, and side views of SAM twin phantom

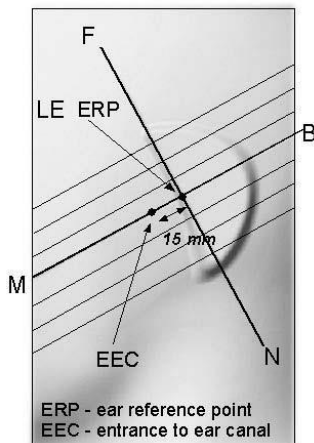

Fig 12.1.2 Close-up side view of phantom showing the ear region.

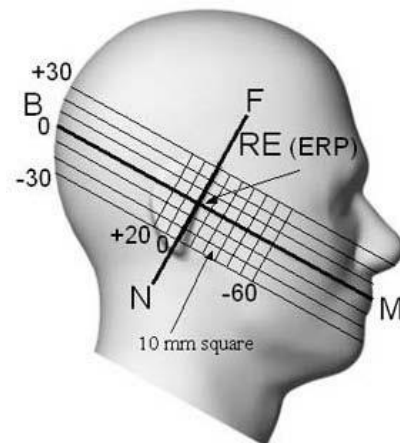

Fig 12.1.3 Side view of the phantom showing relevant markings and seven cross-sectional plane locations

## 12.2 Definition of the cheek position

1. Ready the handset for talk operation, if necessary. For example, for handsets with a cover piece (flip cover), open the cover. If the handset can transmit with the cover closed, both configurations must be tested.
2. Define two imaginary lines on the handset—the vertical centerline and the horizontal line. The vertical centerline passes through two points on the front side of the handset—the midpoint of the width  $w_t$  of the handset at the level of the acoustic output (point A in Figure 12.2.1 and Figure 12.2.2), and the midpoint of the width  $w_b$  of the bottom of the handset (point B). The horizontal line is perpendicular to the vertical centerline and passes through the center of the acoustic output (see Figure 12.2.1). The two lines intersect at point A. Note that for many handsets, point A coincides with the center of the acoustic output; however, the acoustic output may be located elsewhere on the horizontal line. Also note that the vertical centerline is not necessarily parallel to the front face of the handset (see Figure 12.2.2), especially for clamshell handsets, handsets with flip covers, and other irregularly-shaped handsets.
3. Position the handset close to the surface of the phantom such that point A is on the (virtual) extension of the line passing through points RE and LE on the phantom (see Figure 12.2.3), such that the plane defined by the vertical centerline and the horizontal line of the handset is approximately parallel to the sagittal plane of the phantom.
4. Translate the handset towards the phantom along the line passing through RE and LE until handset point A touches the pinna at the ERP.
5. While maintaining the handset in this plane, rotate it around the LE-RE line until the vertical centerline is in the plane normal to the plane containing B-M and N-F lines, i.e., the Reference Plane.
6. Rotate the handset around the vertical centerline until the handset (horizontal line) is parallel to the N-F line.
7. While maintaining the vertical centerline in the Reference Plane, keeping point A on the line passing through RE and LE, and maintaining the handset contact with the pinna, rotate the handset about the N-F line until any point on the handset is in contact with a phantom point below the pinna on the cheek. See Figure 12.2.3. The actual rotation angles should be documented in the test report.

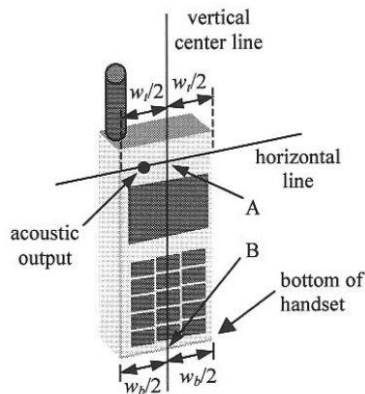

Fig 12.2.1 Handset vertical and horizontal reference lines—“fixed case”

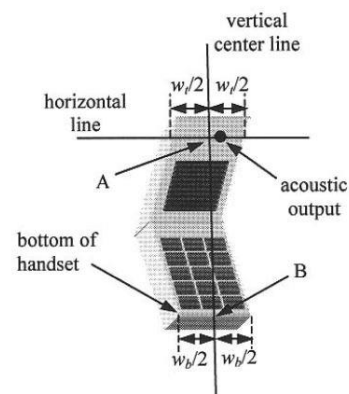

Fig 12.2.2 Handset vertical and horizontal reference lines—“clam-shell case”

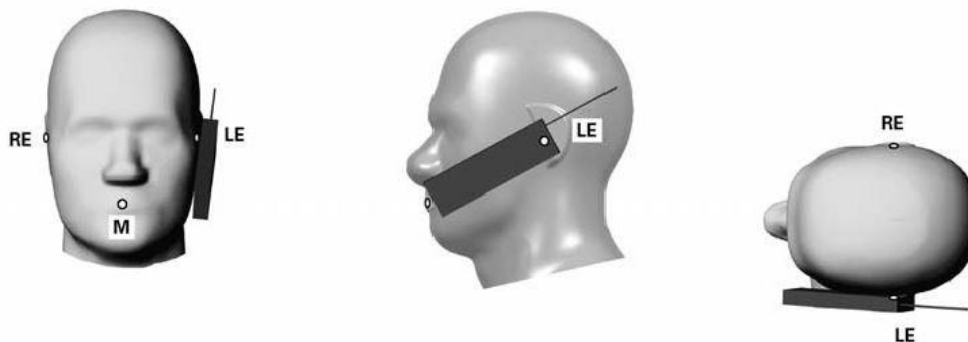

Fig 12.2.3 cheek or touch position. The reference points for the right ear (RE), left ear (LE), and mouth (M), which establish the Reference Plane for handset positioning, are indicated.

### 12.3 Definition of the tilt position

1. Ready the handset for talk operation, if necessary. For example, for handsets with a cover piece (flip cover), open the cover. If the handset can transmit with the cover closed, both configurations must be tested.
2. While maintaining the orientation of the handset, move the handset away from the pinna along the line passing through RE and LE far enough to allow a rotation of the handset away from the cheek by 15°.
3. Rotate the handset around the horizontal line by 15°.
4. While maintaining the orientation of the handset, move the handset towards the phantom on the line passing through RE and LE until any part of the handset touches the ear. The tilt position is obtained when the contact point is on the pinna. See Figure 12.3.1. If contact occurs at any location other than the pinna, e.g., the antenna at the back of the phantom head, the angle of the handset should be reduced. In this case, the tilt position is obtained if any point on the handset is in contact with the pinna and a second point

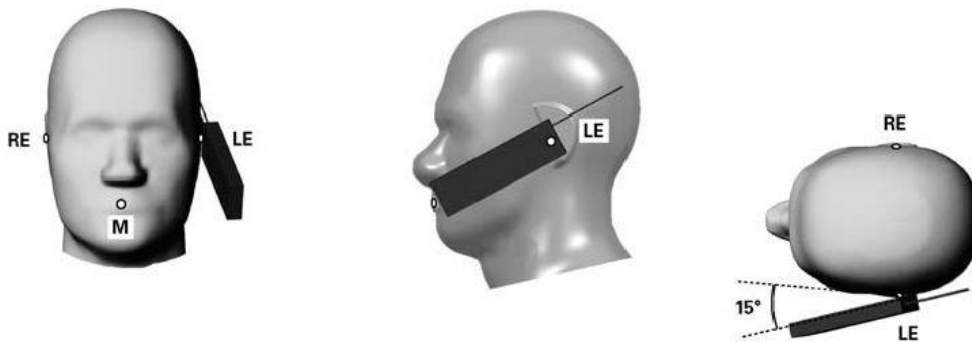

Fig 12.3.1 Tilt position. The reference points for the right ear (RE), left ear (LE), and mouth (M), which define the Reference Plane for handset positioning, are indicated.

### 12.4 Body Worn Accessory

Body-worn operating configurations are tested with the belt-clips and holsters attached to the device and positioned against a flat phantom in a normal use configuration (see Figure 12.4). Per KDB648474 D04v01r03, body-worn accessory exposure is typically related to voice mode operations when handsets are carried in body-worn accessories. The body-worn accessory procedures in FCC KDB 447498 D01v06 should be used to test for body-worn accessory SAR compliance, without a headset connected to it. This enables the test results for such configuration to be compatible with that required for hotspot mode when the body-worn accessory test separation distance is greater than or equal to that required for hotspot mode, when applicable. When the reported SAR for body-worn accessory, measured without a headset connected to the handset is  $> 1.2 \text{ W/kg}$ , the highest reported SAR configuration for that wireless mode and frequency band should be repeated for that body-worn accessory with a headset attached to the handset.

Accessories for body-worn operation configurations are divided into two categories: those that do not contain metallic components and those that do contain metallic components. When multiple accessories that do not contain metallic components are supplied with the device, the device is tested with only the accessory that dictates the closest spacing to the body. Then multiple accessories that contain metallic components are tested with the device with each accessory. If multiple accessories share an identical metallic component (i.e. the same metallic belt-clip used with different holsters with no other metallic components) only the accessory that dictates the closest spacing to the body is tested.

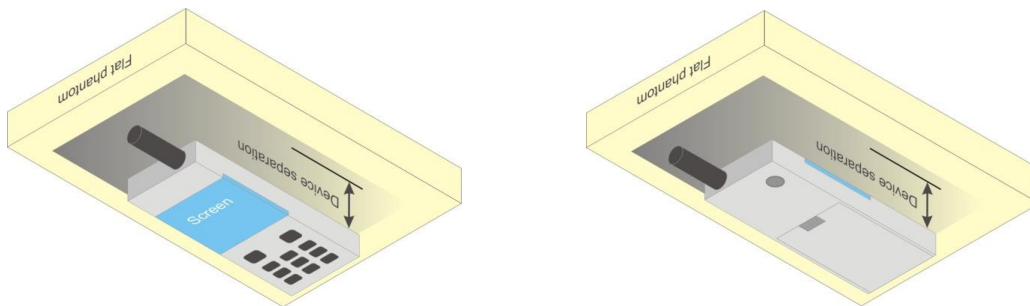

Fig 12.4 Body Worn Position



### **12.5 Product Specific 10g SAR Exposure**

For smart phones with a display diagonal dimension > 15.0 cm or an overall diagonal dimension > 16.0 cm that provide similar mobile web access and multimedia support found in mini-tablets or UMPC mini-tablets that support voice calls next to the ear, According to KDB648474 D04v01r03, the following phablet procedures should be applied to evaluate SAR compliance for each applicable wireless modes and frequency band. Devices marketed as phablets, regardless of form factors and operating characteristics must be tested as a phablet to determine SAR compliance

1. The normally required head and body-worn accessory SAR test procedures for handsets, including hotspot mode, must be applied.
2. The UMPC mini-tablet procedures must also be applied to test the SAR of all surfaces and edges with an antenna located at  $\leq 25$  mm from that surface or edge, in direct contact with a flat phantom, for 10-g extremity SAR according to the body-equivalent tissue dielectric parameters in KDB 865664 to address interactive hand use exposure conditions.6 The UMPC mini-tablet 1-g SAR at 5 mm is not required. When hotspot mode applies, 10-g extremity SAR is required only for the surfaces and edges with hotspot mode 1-g reported SAR > 1.2 W/kg.

### **12.6 Wireless Router**

Some battery-operated handsets have the capability to transmit and receive user through simultaneous transmission of WIFI simultaneously with a separate licensed transmitter. The FCC has provided guidance in FCC KDB Publication 941225 D06 v02r01 where SAR test considerations for handsets (L x W  $\geq 9$  cm x 5 cm) are based on a composite test separation distance of 10mm from the front, back and edges of the device containing transmitting antennas within 2.5cm of their edges, determined from general mixed use conditions for this type of devices. Since the hotspot SAR results may overlap with the body-worn accessory SAR requirements, the more conservative configurations can be considered, thus excluding some body-worn accessory SAR tests.

When the user enables the personal wireless router functions for the handset, actual operations include simultaneous transmission of both the WIFI transmitter and another licensed transmitter. Both transmitters often do not transmit at the same transmitting frequency and thus cannot be evaluated for SAR under actual use conditions due to the limitations of the SAR assessment probes. Therefore, SAR must be evaluated for each frequency transmission and mode separately and spatially summed with the WIFI transmitter according to FCC KDB Publication 447498 D01v06 publication procedures. The "Portable Hotspot" feature on the handset was NOT activated during SAR assessments, to ensure the SAR measurements were evaluated for a single transmission frequency RF signal at a time.

### 13. Conducted RF Output Power (Unit: dBm)

**<GSM Conducted Power>**

1. Per KDB 447498 D01v06, the maximum output power channel is used for SAR testing and for further SAR test reduction.
2. Per KDB 941225 D01v03r01, for SAR test reduction for GSM / GPRS / EDGE modes is determined by the source-based time-averaged output power including tune-up tolerance. The mode with highest specified time-averaged output power should be tested for SAR compliance in the applicable exposure conditions. For modes with the same specified maximum output power and tolerance, the higher number time-slot configuration should be tested. Therefore, the GPRS 2Tx slots for GSM850/GSM1900 are considered as the primary mode.
3. Other configurations of GSM / GPRS / EDGE are considered as secondary modes. The 3G SAR test reduction procedure is applied, when the maximum output power and tune-up tolerance specified for production units in a secondary mode is  $\leq \frac{1}{4}$  dB higher than the primary mode, SAR measurement is not required for the secondary mode.

**<Full Power Mode>**

GSM850 Tx Channel	Burst Average Power (dBm)			Tune-up Limit (dBm)	Frame-Average Power (dBm)			Tune-up Limit (dBm)
	128	189	251		128	189	251	
Frequency (MHz)	824.2	836.4	848.8		824.2	836.4	848.8	
GSM 1 Tx slot	32.16	32.51	32.60	33.50	23.16	23.51	23.60	24.50
GPRS 1 Tx slot	32.13	32.49	32.58	33.50	23.13	23.49	23.58	24.50
GPRS 2 Tx slots	30.11	30.35	30.52	31.50	24.11	24.35	24.52	25.50
GPRS 3 Tx slots	28.50	28.68	28.80	29.50	24.24	24.42	24.54	25.24
GPRS 4 Tx slots	26.92	26.51	26.62	27.50	23.92	23.51	23.62	24.50
EDGE 1 Tx slot	26.39	26.44	26.59	27.50	17.39	17.44	17.59	18.50
EDGE 2 Tx slots	24.22	24.18	24.30	26.00	18.22	18.18	18.30	20.00
EDGE 3 Tx slots	22.01	22.05	22.18	24.00	17.75	17.79	17.92	19.74
EDGE 4 Tx slots	20.52	20.45	20.49	22.00	17.52	17.45	17.49	19.00
<b>GSM1900</b>								
Tx Channel	Burst Average Power (dBm)			Tune-up Limit (dBm)	Frame-Average Power (dBm)			Tune-up Limit (dBm)
	512	661	810		512	661	810	
Frequency (MHz)	1850.2	1880	1909.8		1850.2	1880	1909.8	
GSM 1 Tx slot	29.32	29.51	29.30	30.50	20.32	20.51	20.30	21.50
GPRS 1 Tx slot	29.31	29.49	29.25	30.50	20.31	20.49	20.25	21.50
GPRS 2 Tx slots	27.58	27.72	27.59	28.50	21.58	21.72	21.59	22.50
GPRS 3 Tx slots	25.43	25.53	25.38	26.50	21.17	21.27	21.12	22.24
GPRS 4 Tx slots	23.71	23.73	23.68	24.50	20.71	20.73	20.68	21.50
EDGE 1 Tx slot	25.59	25.63	25.47	27.00	16.59	16.63	16.47	18.00
EDGE 2 Tx slots	23.50	23.53	23.37	24.50	17.50	17.53	17.37	18.50
EDGE 3 Tx slots	21.38	21.45	21.24	22.50	17.12	17.19	16.98	18.24
EDGE 4 Tx slots	19.81	19.70	19.60	21.00	16.81	16.70	16.60	18.00

**Remark:** The frame-averaged power is linearly scaled the maximum burst averaged power over 8 time slots.

The calculated method are shown as below:

Frame-averaged power = Maximum burst averaged power (1 Tx Slot) - 9 dB

Frame-averaged power = Maximum burst averaged power (2 Tx Slots) - 6 dB

Frame-averaged power = Maximum burst averaged power (3 Tx Slots) - 4.26 dB

Frame-averaged power = Maximum burst averaged power (4 Tx Slots) - 3 dB



**<Reduced Power Mode for P-Sensor On/Hotspot On>**

GSM850	Burst Average Power (dBm)			Tune-up Limit (dBm)	Frame-Average Power (dBm)			Tune-up Limit (dBm)
	Tx Channel	128	189		251	128	189	
Frequency (MHz)	824.2	836.4	848.8		824.2	836.4	848.8	
GSM 1 Tx slot	31.18	31.44	31.46	32.00	22.18	22.44	22.46	23.00
GPRS 1 Tx slot	31.17	31.42	31.45	32.00	22.17	22.42	22.45	23.00
GPRS 2 Tx slots	29.05	29.07	29.37	30.00	23.05	23.07	23.37	24.00
GPRS 3 Tx slots	27.64	27.77	27.95	28.00	23.38	23.51	23.69	23.74
GPRS 4 Tx slots	25.33	25.50	25.59	26.00	22.33	22.50	22.59	23.00
EDGE 1 Tx slot	25.62	25.67	25.78	26.00	16.62	16.67	16.78	17.00
EDGE 2 Tx slots	23.54	23.45	23.52	24.50	17.54	17.45	17.52	18.50
EDGE 3 Tx slots	21.45	21.48	21.70	22.50	17.19	17.22	17.44	18.24
EDGE 4 Tx slots	20.11	20.07	20.15	20.50	17.11	17.07	17.15	17.50
GSM1900	Burst Average Power (dBm)			Tune-up Limit (dBm)	Frame-Average Power (dBm)			Tune-up Limit (dBm)
Tx Channel	512	661	810		512	661	810	
Frequency (MHz)	1850.2	1880	1909.8		1850.2	1880	1909.8	
GSM 1 Tx slot	24.65	24.71	24.39	26.00	15.65	15.71	15.39	17.00
GPRS 1 Tx slot	24.64	24.69	24.38	26.00	15.64	15.69	15.38	17.00
GPRS 2 Tx slots	23.09	23.12	22.84	24.00	17.09	17.12	16.84	18.00
GPRS 3 Tx slots	20.97	20.90	21.06	22.00	16.71	16.64	16.80	17.74
GPRS 4 Tx slots	19.37	19.12	19.02	20.00	16.37	16.12	16.02	17.00
EDGE 1 Tx slot	21.91	21.80	21.67	22.50	12.91	12.80	12.67	13.50
EDGE 2 Tx slots	19.07	19.04	19.02	20.00	13.07	13.04	13.02	14.00
EDGE 3 Tx slots	17.04	17.02	17.01	18.00	12.78	12.76	12.75	13.74
EDGE 4 Tx slots	15.58	15.57	15.52	16.50	12.58	12.57	12.52	13.50

**Remark:** The frame-averaged power is linearly scaled the maximum burst averaged power over 8 time slots.

The calculated method are shown as below:

- Frame-averaged power = Maximum burst averaged power (1 Tx Slot) - 9 dB
- Frame-averaged power = Maximum burst averaged power (2 Tx Slots) - 6 dB
- Frame-averaged power = Maximum burst averaged power (3 Tx Slots) - 4.26 dB
- Frame-averaged power = Maximum burst averaged power (4 Tx Slots) - 3 dB

**<WCDMA Conducted Power>**

1. The following tests were conducted according to the test requirements outlines in 3GPP TS 34.121 specification.
2. The procedures in KDB 941225 D01v03r01 are applied for 3GPP Rel. 6 HSPA to configure the device in the required sub-test mode(s) to determine SAR test exclusion.
3. For DC-HSDPA, the device was configured according to the H-Set 12, Fixed Reference Channel (FRC) configuration in Table C.8.1.12 of 3GPP TS 34.121-1, with the primary and the secondary serving HS-DSCH Cell enabled during the power measurement.

A summary of these settings are illustrated below:

**HSDPA Setup Configuration:**

- a. The EUT was connected to Base Station Agilent E5515C referred to the Setup Configuration.
- b. The RF path losses were compensated into the measurements.
- c. A call was established between EUT and Base Station with following setting:
  - i. Set Gain Factors ( $\beta_c$  and  $\beta_d$ ) and parameters were set according to each
  - ii. Specific sub-test in the following table, C10.1.4, quoted from the TS 34.121
  - iii. Set RMC 12.2Kbps + HSDPA mode.
  - iv. Set Cell Power = -86 dBm
  - v. Set HS-DSCH Configuration Type to FRC (H-set 1, QPSK)
  - vi. Select HSDPA Uplink Parameters
  - vii. Set Delta ACK, Delta NACK and Delta CQI = 8
  - viii. Set Ack-Nack Repetition Factor to 3
  - ix. Set CQI Feedback Cycle (k) to 4 ms
  - x. Set CQI Repetition Factor to 2
  - xi. Power Ctrl Mode = All Up bits
- d. The transmitted maximum output power was recorded.

**Table C.10.1.4:  $\beta$  values for transmitter characteristics tests with HS-DPCCH**

Sub-test	$\beta_c$	$\beta_d$	$\beta_d$ (SF)	$\beta_c/\beta_d$	$\beta_{HS}$ (Note 1, Note 2)	CM (dB) (Note 3)	MPR (dB) (Note 3)
1	2/15	15/15	64	2/15	4/15	0.0	0.0
2	12/15 (Note 4)	15/15 (Note 4)	64	12/15 (Note 4)	24/15	1.0	0.0
3	15/15	8/15	64	15/8	30/15	1.5	0.5
4	15/15	4/15	64	15/4	30/15	1.5	0.5

Note 1:  $\Delta_{ACK}, \Delta_{NACK}$  and  $\Delta_{CQI} = 30/15$  with  $\beta_{HS} = 30/15 * \beta_c$ .

Note 2: For the HS-DPCCH power mask requirement test in clause 5.2C, 5.7A, and the Error Vector Magnitude (EVM) with HS-DPCCH test in clause 5.13.1A, and HSDPA EVM with phase discontinuity in clause 5.13.1AA,  $\Delta_{ACK}$  and  $\Delta_{NACK} = 30/15$  with  $\beta_{HS} = 30/15 * \beta_c$ , and  $\Delta_{CQI} = 24/15$  with  $\beta_{HS} = 24/15 * \beta_c$ .

Note 3: CM = 1 for  $\beta_c/\beta_d = 12/15, \beta_{HS}/\beta_c = 24/15$ . For all other combinations of DPDCCH, DPCCH and HS-DPCCH the MPR is based on the relative CM difference. This is applicable for only UEs that support HSDPA in release 6 and later releases.

Note 4: For subtest 2 the  $\beta_c/\beta_d$  ratio of 12/15 for the TFC during the measurement period (TF1, TF0) is achieved by setting the signalled gain factors for the reference TFC (TF1, TF1) to  $\beta_c = 11/15$  and  $\beta_d = 15/15$ .

**Setup Configuration**

**HSUPA Setup Configuration:**

- a. The EUT was connected to Base Station Agilent E5515C referred to the Setup Configuration.
- b. The RF path losses were compensated into the measurements.
- c. A call was established between EUT and Base Station with following setting \* :
  - i. Call Configs = 5.2B, 5.9B, 5.10B, and 5.13.2B with QPSK
  - ii. Set the Gain Factors ( $\beta_c$  and  $\beta_d$ ) and parameters (AG Index) were set according to each specific sub-test in the following table, C11.1.3, quoted from the TS 34.121
  - iii. Set Cell Power = -86 dBm
  - iv. Set Channel Type = 12.2k + HSPA
  - v. Set UE Target Power
  - vi. Power Ctrl Mode= Alternating bits
  - vii. Set and observe the E-TFCI
  - viii. Confirm that E-TFCI is equal to the target E-TFCI of 75 for sub-test 1, and other subtest's E-TFCI
- d. The transmitted maximum output power was recorded.

**Table C.11.1.3:  $\beta$  values for transmitter characteristics tests with HS-DPCCH and E-DCH**

Sub-test	$\beta_c$	$\beta_d$	$\beta_d$ (SF)	$\beta_c/\beta_d$	$\beta_{HS}$ (Note1)	$\beta_{ec}$	$\beta_{ed}$ (Note 4) (Note 5)	$\beta_{ed}$ (SF)	$\beta_{ed}$ (Codes)	CM (dB) (Note 2)	MPR (dB) (Note 2) (Note 6)	AG Index (Note 5)	E-TFCI
1	11/15 (Note 3)	15/15 (Note 3)	64	11/15 (Note 3)	22/15	209/25	1309/225	4	1	1.0	0.0	20	75
2	6/15	15/15	64	6/15	12/15	12/15	94/75	4	1	3.0	2.0	12	67
3	15/15	9/15	64	15/9	30/15	30/15	$\beta_{ed1}$ : 47/15 $\beta_{ed2}$ : 47/15	4 4	2	2.0	1.0	15	92
4	2/15	15/15	64	2/15	4/15	2/15	56/75	4	1	3.0	2.0	17	71
5	15/15	0	-	-	5/15	5/15	47/15	4	1	1.0	0.0	12	67

Note 1: For sub-test 1 to 4,  $\Delta_{ACK}$ ,  $\Delta_{NACK}$  and  $\Delta_{CQI} = 30/15$  with  $\beta_{hs} = 30/15 * \beta_c$ . For sub-test 5,  $\Delta_{ACK}$ ,  $\Delta_{NACK}$  and  $\Delta_{CQI} = 5/15$  with  $\beta_{hs} = 5/15 * \beta_c$ .

Note 2: CM = 1 for  $\beta_c/\beta_d = 12/15$ ,  $\beta_{hs}/\beta_c = 24/15$ . For all other combinations of DPDCH, DPCCH, HS- DPCCH, E-DPDCH and E-DPCCH the MPR is based on the relative CM difference.

Note 3: For subtest 1 the  $\beta_c/\beta_d$  ratio of 11/15 for the TFC during the measurement period (TF1, TF0) is achieved by setting the signalled gain factors for the reference TFC (TF1, TF0) to  $\beta_c = 10/15$  and  $\beta_d = 15/15$ .

Note 4: In case of testing by UE using E-DPDCH Physical Layer category 1, Sub-test 3 is omitted according to TS25.306 Table 5.1g.

Note 5:  $\beta_{ed}$  can not be set directly; it is set by Absolute Grant Value.

Note 6: For subtests 2, 3 and 4, UE may perform E-DPDCH power scaling at max power which could results in slightly smaller MPR values.

**Setup Configuration**

**DC-HSDPA 3GPP release 8 Setup Configuration:**

- a. The EUT was connected to Base Station referred to the Setup Configuration below
- b. The RF path losses were compensated into the measurements.
- c. A call was established between EUT and Base Station with following setting:
  - i. Set RMC 12.2Kbps + HSDPA mode.
  - ii. Set Cell Power = -25 dBm
  - iii. Set HS-DSCH Configuration Type to FRC (H-set 12, QPSK)
  - iv. Select HSDPA Uplink Parameters
  - v. Set Gain Factors ( $\beta_c$  and  $\beta_d$ ) and parameters were set according to each Specific sub-test in the following table, C10.1.4, quoted from the TS 34.121
    - a). Subtest 1:  $\beta_c/\beta_d=2/15$
    - b). Subtest 2:  $\beta_c/\beta_d=12/15$
    - c). Subtest 3:  $\beta_c/\beta_d=15/8$
    - d). Subtest 4:  $\beta_c/\beta_d=15/4$
  - vi. Set Delta ACK, Delta NACK and Delta CQI = 8
  - vii. Set Ack-Nack Repetition Factor to 3
  - viii. Set CQI Feedback Cycle (k) to 4 ms
  - ix. Set CQI Repetition Factor to 2
  - x. Power Ctrl Mode = All Up bits
- d. The transmitted maximum output power was recorded.

The following tests were conducted according to the test requirements outlines in 3GPP TS 34.121 specification. A summary of these settings are illustrated below:

**C.8.1.12 Fixed Reference Channel Definition H-Set 12**

**Table C.8.1.12: Fixed Reference Channel H-Set 12**

Parameter	Unit	Value
Nominal Avg. Inf. Bit Rate	kbps	60
Inter-TTI Distance	TTI's	1
Number of HARQ Processes	Processes	6
Information Bit Payload ( $N_{INF}$ )	Bits	120
Number Code Blocks	Blocks	1
Binary Channel Bits Per TTI	Bits	960
Total Available SML's in UE	SML's	19200
Number of SML's per HARQ Proc.	SML's	3200
Coding Rate		0.15
Number of Physical Channel Codes	Codes	1
Modulation		QPSK
Note 1: The RMC is intended to be used for DC-HSDPA mode and both cells shall transmit with identical parameters as listed in the table. Note 2: Maximum number of transmission is limited to 1, i.e., retransmission is not allowed. The redundancy and constellation version 0 shall be used.		

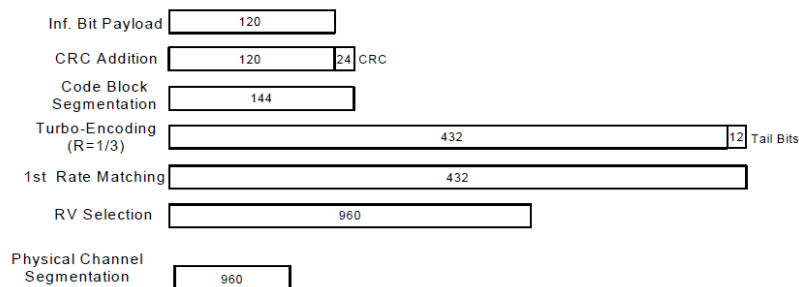

**Figure C.8.19: Coding rate for Fixed reference Channel H-Set 12 (QPSK)**

**Setup Configuration**



<WCDMA Conducted Power>

General Note:

1. Per KDB 941225 D01v03r01, for SAR testing is measured using a 12.2 kbps RMC with TPC bits configured to all "1's".
2. Per KDB 941225 D01v03r01, RMC 12.2kbps setting is used to evaluate SAR. The maximum output power and tune-up tolerance specified for production units in HSDPA / HSUPA / DC-HSDPA is ≤ ¼ dB higher than RMC 12.2Kbps or when the highest reported SAR of the RMC12.2Kbps is scaled by the ratio of specified maximum output power and tune-up tolerance of HSDPA / HSUPA / DC-HSDPA to RMC12.2Kbps and the adjusted SAR is ≤ 1.2 W/kg, SAR measurement is not required for HSDPA / HSUPA / DC-HSDPA, and according to the following RF output power, the output power results of the secondary modes (HSDPA / HSUPA / DC-HSDPA) are less than ¼ dB higher than the primary modes; therefore, SAR measurement is not required for HSDPA / HSUPA / DC-HSDPA

<Full Power Mode>

Band		WCDMA Band II			Tune-up Limit (dBm)	WCDMA Band IV			Tune-up Limit (dBm)	WCDMA Band V			Tune-up Limit (dBm)
Tx Channel		9262	9400	9538		1312	1413	1513		4132	4182	4233	
Rx Channel		9662	9800	9938		1537	1638	1738		4357	4407	4458	
Frequency (MHz)		1852.4	1880	1907.6		1712.4	1732.6	1752.6		826.4	836.4	846.6	
3GPP Rel 99	AMR 12.2Kbps	22.61	22.76	22.70	24.00	22.59	22.69	22.55	24.00	22.61	22.71	22.57	24.00
3GPP Rel 99	RMC 12.2Kbps	22.63	22.78	22.72	24.00	22.60	22.71	22.56	24.00	22.63	22.72	22.58	24.00
3GPP Rel 6	HSDPA Subtest-1	21.64	21.69	21.66	23.00	21.59	21.62	21.56	23.00	21.57	21.70	21.56	23.00
3GPP Rel 6	HSDPA Subtest-2	21.63	21.70	21.66	23.00	21.57	21.63	21.59	23.00	21.59	21.68	21.60	23.00
3GPP Rel 6	HSDPA Subtest-3	21.16	21.25	21.12	22.50	21.08	21.12	21.09	22.50	21.12	21.12	21.17	22.50
3GPP Rel 6	HSDPA Subtest-4	21.12	21.20	21.16	22.50	21.08	21.14	21.07	22.50	21.13	21.16	21.16	22.50
3GPP Rel 8	DC-HSDPA Subtest-1	21.60	21.65	21.65	23.00	21.59	21.64	21.56	23.00	21.56	21.64	21.54	23.00
3GPP Rel 8	DC-HSDPA Subtest-2	21.61	21.66	21.69	23.00	21.55	21.61	21.55	23.00	21.54	21.65	21.55	23.00
3GPP Rel 8	DC-HSDPA Subtest-3	21.11	21.21	21.10	22.50	21.07	21.11	21.00	22.50	21.10	21.11	21.16	22.50
3GPP Rel 8	DC-HSDPA Subtest-4	21.11	21.20	21.11	22.50	21.06	21.13	21.05	22.50	21.13	21.15	21.13	22.50
3GPP Rel 6	HSUPA Subtest-1	21.57	21.71	21.68	23.00	21.57	21.57	21.57	23.00	21.64	21.61	21.65	23.00
3GPP Rel 6	HSUPA Subtest-2	19.63	19.72	19.71	21.00	19.55	19.59	19.54	21.00	19.58	19.54	19.50	21.00
3GPP Rel 6	HSUPA Subtest-3	20.61	20.72	20.69	22.00	20.54	20.62	20.55	22.00	20.64	20.54	20.66	22.00
3GPP Rel 6	HSUPA Subtest-4	19.62	19.65	19.67	21.00	19.55	19.61	19.55	21.00	19.66	19.56	19.64	21.00
3GPP Rel 6	HSUPA Subtest-5	21.70	21.70	21.60	23.00	21.60	21.60	21.60	23.00	21.70	21.56	21.60	23.00



**<Reduced Power Mode for P-Sensor On/Hotspot On>**

Band		WCDMA Band II			Tune-up Limit (dBm)	WCDMA Band IV			Tune-up Limit (dBm)	WCDMA Band V			Tune-up Limit (dBm)
Tx Channel		9262	9400	9538		1312	1413	1513		4132	4182	4233	
Rx Channel		9662	9800	9938		1537	1638	1738		4357	4407	4458	
Frequency (MHz)		1852.4	1880	1907.6		1712.4	1732.6	1752.6		826.4	836.4	846.6	
3GPP Rel 99	AMR 12.2Kbps	14.67	14.84	14.89	16.50	14.06	14.11	14.08	15.50	22.08	22.14	22.06	23.00
3GPP Rel 99	RMC 12.2Kbps	14.68	14.89	14.86	16.50	14.07	14.12	14.10	15.50	22.09	22.16	22.08	23.00
3GPP Rel 6	HSDPA Subtest-1	13.67	13.74	13.71	15.50	13.09	13.15	13.09	14.50	21.15	21.21	21.16	22.00
3GPP Rel 6	HSDPA Subtest-2	13.71	13.79	13.74	15.50	13.08	13.17	13.10	14.50	21.18	21.26	21.20	22.00
3GPP Rel 6	HSDPA Subtest-3	13.19	13.29	13.20	15.00	12.59	12.65	12.56	14.00	20.61	20.72	20.68	21.50
3GPP Rel 6	HSDPA Subtest-4	13.17	13.29	13.18	15.00	12.58	12.62	12.59	14.00	20.65	20.72	20.65	21.50
3GPP Rel 8	DC-HSDPA Subtest-1	13.60	13.62	13.67	15.50	13.03	13.10	13.03	14.50	21.08	21.16	21.11	22.00
3GPP Rel 8	DC-HSDPA Subtest-2	13.64	13.70	13.69	15.50	13.04	13.11	13.01	14.50	21.10	21.19	21.15	22.00
3GPP Rel 8	DC-HSDPA Subtest-3	13.12	13.21	13.14	15.00	12.49	12.60	12.43	14.00	20.43	20.64	20.55	21.50
3GPP Rel 8	DC-HSDPA Subtest-4	13.11	13.20	13.12	15.00	12.50	12.57	12.41	14.00	20.52	20.57	20.57	21.50
3GPP Rel 6	HSUPA Subtest-1	13.62	13.76	13.66	15.50	13.03	13.10	13.07	14.50	21.15	21.24	21.12	22.00
3GPP Rel 6	HSUPA Subtest-2	11.64	11.76	11.66	13.50	11.11	11.12	11.08	12.50	19.18	19.23	19.09	20.00
3GPP Rel 6	HSUPA Subtest-3	12.65	12.77	12.67	14.50	12.00	12.10	12.07	13.50	20.09	20.25	20.15	21.00
3GPP Rel 6	HSUPA Subtest-4	11.68	11.75	11.68	13.50	11.06	11.11	11.04	12.50	19.17	19.25	19.12	20.00
3GPP Rel 6	HSUPA Subtest-5	13.70	13.80	13.70	15.50	13.10	13.10	13.00	14.50	21.10	21.30	21.20	22.00

**<Reduced Power Mode for Handheld On>**

Band		WCDMA Band II			Tune-up Limit (dBm)	WCDMA Band IV			Tune-up Limit (dBm)
Tx Channel		9262	9400	9538		1312	1413	1513	
Rx Channel		9662	9800	9938		1537	1638	1738	
Frequency (MHz)		1852.4	1880	1907.6		1712.4	1732.6	1752.6	
3GPP Rel 99	AMR 12.2Kbps	20.20	20.35	20.36	21.50	20.22	20.33	20.25	21.00
3GPP Rel 99	RMC 12.2Kbps	20.21	20.38	20.36	21.50	20.31	20.35	20.29	21.00
3GPP Rel 6	HSDPA Subtest-1	19.16	19.21	19.17	20.50	19.07	19.09	19.06	20.00
3GPP Rel 6	HSDPA Subtest-2	19.17	19.24	19.19	20.50	19.08	19.14	19.07	20.00
3GPP Rel 6	HSDPA Subtest-3	18.68	18.77	18.68	20.00	18.55	18.65	18.61	19.50
3GPP Rel 6	HSDPA Subtest-4	18.68	18.79	18.69	20.00	18.56	18.66	18.59	19.50
3GPP Rel 8	DC-HSDPA Subtest-1	19.11	19.05	19.12	20.50	19.03	19.02	19.12	20.00
3GPP Rel 8	DC-HSDPA Subtest-2	19.09	19.22	19.21	20.50	19.12	18.98	19.08	20.00
3GPP Rel 8	DC-HSDPA Subtest-3	18.54	18.42	18.65	20.00	18.87	18.52	18.63	19.50
3GPP Rel 8	DC-HSDPA Subtest-4	18.56	18.63	18.69	20.00	18.65	18.49	18.66	19.50
3GPP Rel 6	HSUPA Subtest-1	19.16	19.24	19.14	20.50	19.13	19.15	19.04	20.00
3GPP Rel 6	HSUPA Subtest-2	17.16	17.29	17.19	18.50	17.07	17.08	17.06	18.00
3GPP Rel 6	HSUPA Subtest-3	18.14	18.28	18.18	19.50	18.07	18.10	18.01	19.00
3GPP Rel 6	HSUPA Subtest-4	17.10	17.22	17.14	18.50	17.07	17.12	17.09	18.00
3GPP Rel 6	HSUPA Subtest-5	19.20	19.20	19.20	20.50	19.10	19.10	19.10	20.00

**<LTE Conducted Power>**

**General Note:**

1. Anritsu MT8821C base station simulator was used to setup the connection with EUT; the frequency band, channel bandwidth, RB allocation configuration, modulation type are set in the base station simulator to configure EUT transmitting at maximum power and at different configurations which are requested to be reported to FCC, for conducted power measurement and SAR testing.
2. Per KDB 941225 D05v02r05, when a properly configured base station simulator is used for the SAR and power measurements, spectrum plots for each RB allocation and offset configuration is not required.
3. Per KDB 941225 D05v02r05, start with the largest channel bandwidth and measure SAR for QPSK with 1 RB allocation, using the RB offset and required test channel combination with the highest maximum output power for RB offsets at the upper edge, middle and lower edge of each required test channel.
4. Per KDB 941225 D05v02r05, 50% RB allocation for QPSK SAR testing follows 1RB QPSK allocation procedure.
5. Per KDB 941225 D05v02r05, for QPSK with 100% RB allocation, SAR is not required when the highest maximum output power for 100 % RB allocation is less than the highest maximum output power in 50% and 1 RB allocations and the highest reported SAR for 1 RB and 50% RB allocation are  $\leq 0.8$  W/kg. Otherwise, SAR is measured for the highest output power channel; and if the reported SAR is  $> 1.45$  W/kg, the remaining required test channels must also be tested.
6. Per KDB 941225 D05v02r05, 16QAM/64QAM output power for each RB allocation configuration is  $>$  not  $\frac{1}{2}$  dB higher than the same configuration in QPSK and the reported SAR for the QPSK configuration is  $\leq 1.45$  W/kg; Per KDB 941225 D05v02r05, 16QAM/64QAM SAR testing is not required.
7. Per KDB 941225 D05v02r05, smaller bandwidth output power for each RB allocation configuration is  $>$  not  $\frac{1}{2}$  dB higher than the same configuration in the largest supported bandwidth, and the reported SAR for the largest supported bandwidth is  $\leq 1.45$  W/kg; Per KDB 941225 D05v02r05, smaller bandwidth SAR testing is not required.
8. For LTE B4 / B5 the maximum bandwidth does not support three non-overlapping channels, per KDB 941225 D05v02r05, when a device supports overlapping channel assignment in a channel bandwidth configuration, the middle channel of the group of overlapping channels should be selected for testing.
9. LTE B4 SAR test was covered by B66; according to April 2015 TCB workshop, SAR test for overlapping LTE bands can be reduced if
  - a. the maximum output power, including tolerance, for the smaller band is  $\leq$  the larger band to qualify for the SAR test exclusion
  - b. the channel bandwidth and other operating parameters for the smaller band are fully supported by the larger band
10. According to 2017 TCB workshop, for 64 QAM and 16 QAM should be verified by checking the signal constellation with a call box to avoid incorrect maximum power levels due to MPR and other requirements associated with signal modulation, and the following figure is taken from the "Fundamental Measurement >> Modulation Analysis >> constellation" mode of the device connect to the MT8821C base station, therefore, the device 64QAM and 16QAM signal modulation are correct.

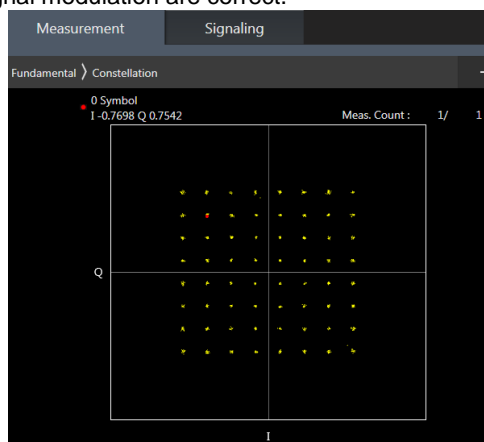

**64QAM**



**16QAM**



<Full Power Mode>

<LTE Band 2>

BW [MHz]	Modulation	RB Size	RB Offset	Power Low Ch. / Freq.	Power Middle Ch. / Freq.	Power High Ch. / Freq.	Tune-up limit (dBm)	MPR (dB)
Channel				18700	18900	19100		
Frequency (MHz)				1860	1880	1900		
20	QPSK	1	0	22.82	22.89	22.66	24	0
20	QPSK	1	49	22.44	22.57	22.47		
20	QPSK	1	99	22.66	22.69	22.46		
20	QPSK	50	0	21.57	21.67	21.58	23	1
20	QPSK	50	24	21.52	21.62	21.49		
20	QPSK	50	50	21.56	21.53	21.47		
20	QPSK	100	0	21.61	21.63	21.51		
20	16QAM	1	0	22.26	22.35	22.11	23	1
20	16QAM	1	49	21.91	21.97	21.99		
20	16QAM	1	99	22.10	22.10	21.89		
20	16QAM	50	0	20.73	20.82	20.72	22	2
20	16QAM	50	24	20.65	20.74	20.65		
20	16QAM	50	50	20.72	20.70	20.60		
20	16QAM	100	0	20.76	20.76	20.68		
20	64QAM	1	0	21.16	21.23	21.01	22	2
20	64QAM	1	49	20.78	20.89	20.80		
20	64QAM	1	99	20.99	21.03	20.76		
20	64QAM	50	0	19.71	19.80	19.70	21	3
20	64QAM	50	24	19.62	19.73	19.64		
20	64QAM	50	50	19.71	19.69	19.58		
20	64QAM	100	0	19.76	19.75	19.65		
Channel				18675	18900	19125	Tune-up limit (dBm)	MPR (dB)
Frequency (MHz)				1857.5	1880	1902.5		
15	QPSK	1	0	22.65	22.73	22.63	24	0
15	QPSK	1	37	22.45	22.53	22.44		
15	QPSK	1	74	22.42	22.58	22.49		
15	QPSK	36	0	21.57	21.68	21.56	23	1
15	QPSK	36	20	21.52	21.59	21.52		
15	QPSK	36	39	21.47	21.56	21.46		
15	QPSK	75	0	21.48	21.62	21.50		
15	16QAM	1	0	22.10	22.16	22.12	23	1
15	16QAM	1	37	21.94	21.97	21.93		
15	16QAM	1	74	21.87	21.99	21.89		
15	16QAM	36	0	20.71	20.78	20.70	22	2
15	16QAM	36	20	20.69	20.74	20.68		
15	16QAM	36	39	20.63	20.69	20.64		
15	16QAM	75	0	20.66	20.73	20.62		
15	64QAM	1	0	20.96	21.06	20.97	22	2
15	64QAM	1	37	20.77	20.83	20.79		
15	64QAM	1	74	20.77	20.87	20.80		
15	64QAM	36	0	19.71	19.78	19.69	21	3
15	64QAM	36	20	19.67	19.75	19.68		
15	64QAM	36	39	19.60	19.70	19.60		
15	64QAM	75	0	19.67	19.74	19.65		





Channel				18650	18900	19150	Tune-up limit (dBm)	MPR (dB)
Frequency (MHz)				1855	1880	1905		
10	QPSK	1	0	22.74	22.85	22.53	24	0
10	QPSK	1	25	22.43	22.54	22.41		
10	QPSK	1	49	22.58	22.69	22.38		
10	QPSK	25	0	21.51	21.60	21.47	23	1
10	QPSK	25	12	21.46	21.59	21.46		
10	QPSK	25	25	21.46	21.54	21.43		
10	QPSK	50	0	21.50	21.56	21.47		
10	16QAM	1	0	22.17	22.27	21.98	23	1
10	16QAM	1	25	21.86	22.00	21.90		
10	16QAM	1	49	22.10	22.19	21.83		
10	16QAM	25	0	20.66	20.75	20.64	22	2
10	16QAM	25	12	20.63	20.73	20.62		
10	16QAM	25	25	20.62	20.70	20.57		
10	16QAM	50	0	20.63	20.71	20.60		
10	64QAM	1	0	21.05	21.14	20.86	22	2
10	64QAM	1	25	20.77	20.87	20.77		
10	64QAM	1	49	20.93	21.04	20.75		
10	64QAM	25	0	19.67	19.74	19.62	21	3
10	64QAM	25	12	19.65	19.70	19.60		
10	64QAM	25	25	19.59	19.67	19.59		
10	64QAM	50	0	19.60	19.73	19.58		
Channel				18625	18900	19175	Tune-up limit (dBm)	MPR (dB)
Frequency (MHz)				1852.5	1880	1907.5		
5	QPSK	1	0	22.50	22.62	22.47	24	0
5	QPSK	1	12	22.42	22.53	22.42		
5	QPSK	1	24	22.45	22.55	22.44		
5	QPSK	12	0	21.50	21.57	21.50	23	1
5	QPSK	12	7	21.48	21.57	21.46		
5	QPSK	12	13	21.43	21.57	21.45		
5	QPSK	25	0	21.45	21.53	21.45		
5	16QAM	1	0	21.95	22.02	21.93	23	1
5	16QAM	1	12	21.85	21.97	21.85		
5	16QAM	1	24	21.86	21.98	21.84		
5	16QAM	12	0	20.67	20.73	20.63	22	2
5	16QAM	12	7	20.62	20.69	20.62		
5	16QAM	12	13	20.62	20.68	20.58		
5	16QAM	25	0	20.59	20.68	20.57		
5	64QAM	1	0	20.80	20.92	20.83	22	2
5	64QAM	1	12	20.80	20.85	20.72		
5	64QAM	1	24	20.72	20.87	20.77		
5	64QAM	12	0	19.64	19.71	19.60	21	3
5	64QAM	12	7	19.61	19.66	19.61		
5	64QAM	12	13	19.59	19.67	19.56		
5	64QAM	25	0	19.61	19.66	19.57		



Channel				18615	18900	19185	Tune-up limit (dBm)	MPR (dB)
Frequency (MHz)				1851.5	1880	1908.5		
3	QPSK	1	0	22.11	22.31	22.22	24	0
3	QPSK	1	8	22.19	22.24	22.23		
3	QPSK	1	14	22.09	22.22	22.09		
3	QPSK	8	0	21.19	21.24	21.21	23	1
3	QPSK	8	4	21.14	21.21	21.14		
3	QPSK	8	7	21.24	21.32	21.15		
3	QPSK	15	0	21.16	21.20	21.12		
3	16QAM	1	0	21.48	21.66	21.82	23	1
3	16QAM	1	8	21.85	21.95	21.67		
3	16QAM	1	14	21.54	21.50	21.55		
3	16QAM	8	0	20.34	20.42	20.41	22	2
3	16QAM	8	4	20.45	20.41	20.46		
3	16QAM	8	7	20.27	20.40	20.30		
3	16QAM	15	0	20.31	20.31	20.21		
3	64QAM	1	0	20.40	20.56	20.48	22	2
3	64QAM	1	8	20.68	20.52	20.38		
3	64QAM	1	14	20.35	20.43	20.21		
3	64QAM	8	0	19.41	19.51	19.18	21	3
3	64QAM	8	4	19.49	19.34	19.34		
3	64QAM	8	7	19.25	19.25	19.35		
3	64QAM	15	0	19.22	19.29	19.24		
Channel				18607	18900	19193	Tune-up limit (dBm)	MPR (dB)
Frequency (MHz)				1850.7	1880	1909.3		
1.4	QPSK	1	0	22.26	22.44	22.28	24	0
1.4	QPSK	1	3	22.37	22.44	22.33		
1.4	QPSK	1	5	22.27	22.39	22.25		
1.4	QPSK	3	0	22.35	22.43	22.33		
1.4	QPSK	3	1	22.35	22.44	22.32		
1.4	QPSK	3	3	22.32	22.43	22.30	23	1
1.4	QPSK	6	0	21.33	21.40	21.27	23	1
1.4	16QAM	1	0	21.68	21.84	21.70		
1.4	16QAM	1	3	21.79	21.87	21.78		
1.4	16QAM	1	5	21.69	21.77	21.65		
1.4	16QAM	3	0	21.48	21.61	21.46		
1.4	16QAM	3	1	21.54	21.62	21.45		
1.4	16QAM	3	3	21.48	21.56	21.43	22	2
1.4	16QAM	6	0	20.52	20.61	20.48	22	2
1.4	64QAM	1	0	20.61	20.74	20.59		
1.4	64QAM	1	3	20.71	20.74	20.62		
1.4	64QAM	1	5	20.58	20.71	20.53		
1.4	64QAM	3	0	20.50	20.63	20.49		
1.4	64QAM	3	1	20.59	20.63	20.51		
1.4	64QAM	3	3	20.53	20.60	20.47		
1.4	64QAM	6	0	19.46	19.51	19.39	21	3



<LTE Band 4>

BW [MHz]	Modulation	RB Size	RB Offset	Power Low Ch. / Freq.	Power Middle Ch. / Freq.	Power High Ch. / Freq.	Tune-up limit (dBm)	MPR (dB)
Channel				20050	20175	20300		
Frequency (MHz)				1720	1732.5	1745		
20	QPSK	1	0	22.37	22.28	22.38	24	0
20	QPSK	1	49	22.35	22.45	22.33		
20	QPSK	1	99	22.25	22.22	22.16		
20	QPSK	50	0	21.34	21.42	21.36	23	1
20	QPSK	50	24	21.40	21.37	21.30		
20	QPSK	50	50	21.38	21.30	21.24		
20	QPSK	100	0	21.41	21.42	21.31	23	1
20	16QAM	1	0	21.78	21.79	21.81		
20	16QAM	1	49	21.77	21.82	21.72		
20	16QAM	1	99	21.72	21.66	21.59	22	2
20	16QAM	50	0	20.48	20.52	20.45		
20	16QAM	50	24	20.55	20.49	20.46		
20	16QAM	50	50	20.47	20.45	20.40	22	2
20	16QAM	100	0	20.50	20.47	20.38		
20	64QAM	1	0	20.67	20.66	20.69		
20	64QAM	1	49	20.68	20.63	20.62	22	2
20	64QAM	1	99	20.60	20.52	20.51		
20	64QAM	50	0	19.50	19.48	19.44		
20	64QAM	50	24	19.55	19.48	19.44	21	3
20	64QAM	50	50	19.45	19.40	19.36		
20	64QAM	100	0	19.48	19.47	19.39		
Channel				20025	20175	20325	Tune-up limit (dBm)	MPR (dB)
Frequency (MHz)				1717.5	1732.5	1747.5		
15	QPSK	1	0	22.33	22.41	22.36	24	0
15	QPSK	1	37	22.30	22.35	22.29		
15	QPSK	1	74	22.33	22.24	22.20		
15	QPSK	36	0	21.39	21.41	21.31	23	1
15	QPSK	36	20	21.34	21.41	21.34		
15	QPSK	36	39	21.38	21.34	21.29		
15	QPSK	75	0	21.38	21.39	21.29	23	1
15	16QAM	1	0	21.86	21.84	21.74		
15	16QAM	1	37	21.70	21.77	21.67		
15	16QAM	1	74	21.75	21.68	21.64	22	2
15	16QAM	36	0	20.49	20.57	20.44		
15	16QAM	36	20	20.49	20.51	20.46		
15	16QAM	36	39	20.52	20.46	20.38	22	2
15	16QAM	75	0	20.52	20.50	20.40		
15	64QAM	1	0	20.74	20.71	20.66		
15	64QAM	1	37	20.66	20.68	20.56	22	2
15	64QAM	1	74	20.60	20.51	20.48		
15	64QAM	36	0	19.47	19.54	19.40		
15	64QAM	36	20	19.50	19.53	19.46	21	3
15	64QAM	36	39	19.52	19.43	19.37		
15	64QAM	75	0	19.57	19.50	19.40		



Channel				20000	20175	20350	Tune-up limit (dBm)	MPR (dB)
Frequency (MHz)				1715	1732.5	1750		
10	QPSK	1	0	22.34	22.41	22.34	24	0
10	QPSK	1	25	22.32	22.35	22.31		
10	QPSK	1	49	22.26	22.28	22.21		
10	QPSK	25	0	21.35	21.41	21.34	23	1
10	QPSK	25	12	21.33	21.40	21.32		
10	QPSK	25	25	21.28	21.33	21.26		
10	QPSK	50	0	21.31	21.38	21.33		
10	16QAM	1	0	21.78	21.89	21.74	23	1
10	16QAM	1	25	21.73	21.79	21.70		
10	16QAM	1	49	21.72	21.70	21.67		
10	16QAM	25	0	20.46	20.50	20.46	22	2
10	16QAM	25	12	20.48	20.52	20.41		
10	16QAM	25	25	20.45	20.46	20.41		
10	16QAM	50	0	20.45	20.46	20.43		
10	64QAM	1	0	20.65	20.73	20.65	22	2
10	64QAM	1	25	20.62	20.67	20.57		
10	64QAM	1	49	20.58	20.62	20.56		
10	64QAM	25	0	19.47	19.50	19.46	21	3
10	64QAM	25	12	19.49	19.51	19.42		
10	64QAM	25	25	19.43	19.43	19.39		
10	64QAM	50	0	19.47	19.49	19.42		
Channel				19975	20175	20375	Tune-up limit (dBm)	MPR (dB)
Frequency (MHz)				1712.5	1732.5	1752.5		
5	QPSK	1	0	22.29	22.34	22.26	24	0
5	QPSK	1	12	22.30	22.34	22.27		
5	QPSK	1	24	22.23	22.28	22.23		
5	QPSK	12	0	21.34	21.39	21.31	23	1
5	QPSK	12	7	21.33	21.41	21.32		
5	QPSK	12	13	21.32	21.38	21.28		
5	QPSK	25	0	21.30	21.35	21.28		
5	16QAM	1	0	21.76	21.78	21.70	23	1
5	16QAM	1	12	21.72	21.80	21.72		
5	16QAM	1	24	21.65	21.72	21.62		
5	16QAM	12	0	20.50	20.51	20.44	22	2
5	16QAM	12	7	20.52	20.55	20.46		
5	16QAM	12	13	20.45	20.47	20.41		
5	16QAM	25	0	20.45	20.46	20.37		
5	64QAM	1	0	20.68	20.69	20.62	22	2
5	64QAM	1	12	20.59	20.61	20.61		
5	64QAM	1	24	20.60	20.62	20.53		
5	64QAM	12	0	19.48	19.49	19.42	21	3
5	64QAM	12	7	19.51	19.52	19.46		
5	64QAM	12	13	19.48	19.45	19.39		
5	64QAM	25	0	19.44	19.44	19.38		



Channel				19965	20175	20385	Tune-up limit (dBm)	MPR (dB)
Frequency (MHz)				1711.5	1732.5	1753.5		
3	QPSK	1	0	22.32	22.43	22.30	24	0
3	QPSK	1	8	22.29	22.39	22.29		
3	QPSK	1	14	22.33	22.37	22.29		
3	QPSK	8	0	21.36	21.41	21.36	23	1
3	QPSK	8	4	21.41	21.43	21.37		
3	QPSK	8	7	21.38	21.43	21.33		
3	QPSK	15	0	21.36	21.42	21.32		
3	16QAM	1	0	21.80	21.84	21.72	23	1
3	16QAM	1	8	21.81	21.85	21.72		
3	16QAM	1	14	21.72	21.78	21.71		
3	16QAM	8	0	20.59	20.61	20.51	22	2
3	16QAM	8	4	20.59	20.65	20.56		
3	16QAM	8	7	20.57	20.60	20.52		
3	16QAM	15	0	20.50	20.54	20.45		
3	64QAM	1	0	20.67	20.68	20.59	22	2
3	64QAM	1	8	20.65	20.71	20.63		
3	64QAM	1	14	20.60	20.64	20.60		
3	64QAM	8	0	19.53	19.54	19.46	21	3
3	64QAM	8	4	19.58	19.58	19.49		
3	64QAM	8	7	19.52	19.53	19.47		
3	64QAM	15	0	19.45	19.51	19.43		
Channel				19957	20175	20393	Tune-up limit (dBm)	MPR (dB)
Frequency (MHz)				1710.7	1732.5	1754.3		
1.4	QPSK	1	0	22.23	22.29	22.22	24	0
1.4	QPSK	1	3	22.32	22.35	22.32		
1.4	QPSK	1	5	22.21	22.25	22.20		
1.4	QPSK	3	0	22.30	22.35	22.28		
1.4	QPSK	3	1	22.30	22.38	22.30		
1.4	QPSK	3	3	22.31	22.36	22.31	23	1
1.4	QPSK	6	0	21.29	21.34	21.29	23	1
1.4	16QAM	1	0	21.67	21.73	21.66		
1.4	16QAM	1	3	21.77	21.82	21.73		
1.4	16QAM	1	5	21.65	21.69	21.66		
1.4	16QAM	3	0	21.48	21.50	21.41		
1.4	16QAM	3	1	21.50	21.52	21.46		
1.4	16QAM	3	3	21.46	21.47	21.41	22	2
1.4	16QAM	6	0	20.52	20.50	20.46	22	2
1.4	64QAM	1	0	20.54	20.59	20.54		
1.4	64QAM	1	3	20.64	20.73	20.59		
1.4	64QAM	1	5	20.55	20.60	20.52		
1.4	64QAM	3	0	20.47	20.53	20.43		
1.4	64QAM	3	1	20.52	20.59	20.48		
1.4	64QAM	3	3	20.50	20.50	20.49		
1.4	64QAM	6	0	19.41	19.46	19.37	21	3



<LTE Band 5>

BW [MHz]	Modulation	RB Size	RB Offset	Power Low Ch. / Freq.	Power Middle Ch. / Freq.	Power High Ch. / Freq.	Tune-up limit (dBm)	MPR (dB)
Channel				20450	20525	20600		
Frequency (MHz)				829	836.5	844		
10	QPSK	1	0	22.64	22.76	22.51	24	0
10	QPSK	1	25	22.59	22.53	22.56		
10	QPSK	1	49	22.54	22.55	22.47		
10	QPSK	25	0	21.66	21.67	21.54	23	1
10	QPSK	25	12	21.64	21.59	21.58		
10	QPSK	25	25	21.59	21.50	21.52		
10	QPSK	50	0	21.63	21.64	21.49	23	1
10	16QAM	1	0	22.05	21.93	21.89		
10	16QAM	1	25	21.95	21.91	21.97		
10	16QAM	1	49	21.89	21.94	21.86	22	2
10	16QAM	25	0	20.79	20.73	20.64		
10	16QAM	25	12	20.75	20.69	20.75		
10	16QAM	25	25	20.69	20.65	20.63	22	2
10	16QAM	50	0	20.73	20.72	20.63		
10	64QAM	1	0	20.93	20.84	20.78		
10	64QAM	1	25	20.87	20.81	20.82	22	2
10	64QAM	1	49	20.77	20.82	20.76		
10	64QAM	25	0	19.78	19.73	19.64		
10	64QAM	25	12	19.75	19.69	19.71	21	3
10	64QAM	25	25	19.69	19.66	19.66		
10	64QAM	50	0	19.72	19.70	19.60		
Channel				20425	20525	20625	Tune-up limit (dBm)	MPR (dB)
Frequency (MHz)				826.5	836.5	846.5		
5	QPSK	1	0	22.65	22.58	22.54	24	0
5	QPSK	1	12	22.61	22.52	22.51		
5	QPSK	1	24	22.61	22.49	22.45		
5	QPSK	12	0	21.67	21.59	21.57	23	1
5	QPSK	12	7	21.70	21.58	21.57		
5	QPSK	12	13	21.66	21.55	21.51		
5	QPSK	25	0	21.68	21.54	21.52	23	1
5	16QAM	1	0	22.04	21.94	21.93		
5	16QAM	1	12	21.97	21.89	21.91		
5	16QAM	1	24	21.99	21.87	21.86	22	2
5	16QAM	12	0	20.79	20.69	20.66		
5	16QAM	12	7	20.80	20.68	20.67		
5	16QAM	12	13	20.76	20.66	20.63	22	2
5	16QAM	25	0	20.77	20.66	20.63		
5	64QAM	1	0	20.90	20.80	20.83		
5	64QAM	1	12	20.92	20.78	20.80	22	2
5	64QAM	1	24	20.85	20.73	20.75		
5	64QAM	12	0	19.77	19.67	19.63		
5	64QAM	12	7	19.77	19.67	19.66	21	3
5	64QAM	12	13	19.74	19.65	19.61		
5	64QAM	25	0	19.77	19.66	19.62		



Channel				20415	20525	20635	Tune-up limit (dBm)	MPR (dB)
Frequency (MHz)				825.5	836.5	847.5		
3	QPSK	1	0	22.63	22.53	22.51	24	0
3	QPSK	1	8	22.61	22.48	22.46		
3	QPSK	1	14	22.62	22.49	22.49		
3	QPSK	8	0	21.64	21.54	21.50	23	1
3	QPSK	8	4	21.66	21.54	21.54		
3	QPSK	8	7	21.65	21.49	21.52		
3	QPSK	15	0	21.63	21.54	21.49		
3	16QAM	1	0	21.98	21.87	21.85	23	1
3	16QAM	1	8	22.02	21.85	21.86		
3	16QAM	1	14	21.97	21.83	21.84		
3	16QAM	8	0	20.82	20.70	20.70	22	2
3	16QAM	8	4	20.84	20.70	20.71		
3	16QAM	8	7	20.83	20.70	20.66		
3	16QAM	15	0	20.78	20.65	20.61		
3	64QAM	1	0	20.90	20.74	20.76	22	2
3	64QAM	1	8	20.87	20.75	20.75		
3	64QAM	1	14	20.86	20.74	20.74		
3	64QAM	8	0	19.79	19.68	19.66	21	3
3	64QAM	8	4	19.79	19.66	19.68		
3	64QAM	8	7	19.77	19.65	19.62		
3	64QAM	15	0	19.73	19.63	19.62		
Channel				20407	20525	20643	Tune-up limit (dBm)	MPR (dB)
Frequency (MHz)				824.7	836.5	848.3		
1.4	QPSK	1	0	22.52	22.37	22.37	24	0
1.4	QPSK	1	3	22.57	22.47	22.42		
1.4	QPSK	1	5	22.50	22.36	22.36		
1.4	QPSK	3	0	22.60	22.44	22.42		
1.4	QPSK	3	1	22.58	22.45	22.44		
1.4	QPSK	3	3	22.54	22.47	22.44	23	1
1.4	QPSK	6	0	21.56	21.44	21.39		
1.4	16QAM	1	0	22.71	22.63	22.67	23	1
1.4	16QAM	1	3	22.70	22.50	22.74		
1.4	16QAM	1	5	22.71	22.67	22.65		
1.4	16QAM	3	0	22.59	22.49	22.47		
1.4	16QAM	3	1	22.64	22.52	22.51		
1.4	16QAM	3	3	22.61	22.45	22.42	22	2
1.4	16QAM	6	0	20.70	20.60	20.60		
1.4	64QAM	1	0	21.69	21.59	21.54	22	2
1.4	64QAM	1	3	21.79	21.62	21.60		
1.4	64QAM	1	5	21.71	21.59	21.49		
1.4	64QAM	3	0	21.64	21.54	21.51		
1.4	64QAM	3	1	21.67	21.56	21.55		
1.4	64QAM	3	3	21.62	21.47	21.47		
1.4	64QAM	6	0	19.64	19.52	19.48	21	3



<LTE Band 7>

BW [MHz]	Modulation	RB Size	RB Offset	Power Low Ch. / Freq.	Power Middle Ch. / Freq.	Power High Ch. / Freq.	Tune-up limit (dBm)	MPR (dB)
Channel				20850	21100	21350		
Frequency (MHz)				2510	2535	2560		
20	QPSK	1	0	22.58	22.61	22.44	24	0
20	QPSK	1	49	22.62	22.70	22.56		
20	QPSK	1	99	22.76	22.61	22.59		
20	QPSK	50	0	21.67	21.67	21.54	23	1
20	QPSK	50	24	21.77	21.78	21.60		
20	QPSK	50	50	21.80	21.73	21.65		
20	QPSK	100	0	21.71	21.70	21.56	23	1
20	16QAM	1	0	21.99	21.96	21.83		
20	16QAM	1	49	22.02	22.13	21.95		
20	16QAM	1	99	22.11	21.97	21.94	22	2
20	16QAM	50	0	20.77	20.77	20.64		
20	16QAM	50	24	20.86	20.88	20.70		
20	16QAM	50	50	20.86	20.82	20.76	22	2
20	16QAM	100	0	20.79	20.78	20.65		
20	64QAM	1	0	20.86	20.84	20.73		
20	64QAM	1	49	20.88	20.93	20.83	22	2
20	64QAM	1	99	21.01	20.86	20.83		
20	64QAM	50	0	19.77	19.75	19.64		
20	64QAM	50	24	19.85	19.85	19.69	21	3
20	64QAM	50	50	19.84	19.80	19.72		
20	64QAM	100	0	19.80	19.79	19.67		
Channel				20825	21100	21375	Tune-up limit (dBm)	MPR (dB)
Frequency (MHz)				2507.5	2535	2562.5		
15	QPSK	1	0	22.65	22.64	22.50	24	0
15	QPSK	1	37	22.60	22.68	22.58		
15	QPSK	1	74	22.75	22.62	22.61		
15	QPSK	36	0	21.72	21.73	21.60	23	1
15	QPSK	36	20	21.78	21.74	21.61		
15	QPSK	36	39	21.75	21.77	21.61		
15	QPSK	75	0	21.75	21.74	21.60	23	1
15	16QAM	1	0	21.99	22.01	21.85		
15	16QAM	1	37	21.95	22.03	21.89		
15	16QAM	1	74	22.12	21.96	21.98	22	2
15	16QAM	36	0	20.81	20.83	20.70		
15	16QAM	36	20	20.87	20.85	20.71		
15	16QAM	36	39	20.86	20.87	20.71	22	2
15	16QAM	75	0	20.85	20.83	20.70		
15	64QAM	1	0	20.89	20.92	20.76		
15	64QAM	1	37	20.88	20.97	20.84	22	2
15	64QAM	1	74	20.97	20.87	20.84		
15	64QAM	36	0	19.81	19.80	19.70		
15	64QAM	36	20	19.87	19.84	19.71	21	3
15	64QAM	36	39	19.86	19.86	19.69		
15	64QAM	75	0	19.84	19.82	19.71		





Channel				20800	21100	21400	Tune-up limit (dBm)	MPR (dB)
Frequency (MHz)				2505	2535	2565		
10	QPSK	1	0	22.63	22.63	22.51	24	0
10	QPSK	1	25	22.69	22.68	22.57		
10	QPSK	1	49	22.59	22.71	22.55		
10	QPSK	25	0	21.73	21.69	21.54	23	1
10	QPSK	25	12	21.75	21.78	21.61		
10	QPSK	25	25	21.74	21.72	21.62		
10	QPSK	50	0	21.73	21.71	21.62		
10	16QAM	1	0	21.95	22.01	21.84	23	1
10	16QAM	1	25	22.07	22.04	21.90		
10	16QAM	1	49	21.98	22.02	21.95		
10	16QAM	25	0	20.82	20.79	20.64	22	2
10	16QAM	25	12	20.85	20.82	20.71		
10	16QAM	25	25	20.85	20.82	20.73		
10	16QAM	50	0	20.84	20.81	20.68		
10	64QAM	1	0	20.86	20.87	20.74	22	2
10	64QAM	1	25	20.93	20.90	20.80		
10	64QAM	1	49	20.84	20.94	20.80		
10	64QAM	25	0	19.83	19.78	19.64	21	3
10	64QAM	25	12	19.86	19.83	19.70		
10	64QAM	25	25	19.85	19.82	19.68		
10	64QAM	50	0	19.83	19.80	19.63		
Channel				20775	21100	21425	Tune-up limit (dBm)	MPR (dB)
Frequency (MHz)				2502.5	2535	2567.5		
5	QPSK	1	0	22.68	22.63	22.52	24	0
5	QPSK	1	12	22.71	22.68	22.53		
5	QPSK	1	24	22.70	22.68	22.57		
5	QPSK	12	0	21.76	21.72	21.60	23	1
5	QPSK	12	7	21.79	21.78	21.63		
5	QPSK	12	13	21.78	21.76	21.62		
5	QPSK	25	0	21.73	21.72	21.59		
5	16QAM	1	0	21.99	21.99	21.88	23	1
5	16QAM	1	12	22.03	22.00	21.94		
5	16QAM	1	24	22.01	22.03	21.87		
5	16QAM	12	0	20.83	20.82	20.69	22	2
5	16QAM	12	7	20.87	20.82	20.74		
5	16QAM	12	13	20.83	20.82	20.73		
5	16QAM	25	0	20.80	20.83	20.71		
5	64QAM	1	0	20.90	20.91	20.74	22	2
5	64QAM	1	12	20.94	20.93	20.82		
5	64QAM	1	24	20.97	20.90	20.79		
5	64QAM	12	0	19.81	19.81	19.67	21	3
5	64QAM	12	7	19.85	19.82	19.73		
5	64QAM	12	13	19.83	19.78	19.71		
5	64QAM	25	0	19.80	19.82	19.68		



<LTE Band 66>

BW [MHz]	Modulation	RB Size	RB Offset	Power Low Ch. / Freq.	Power Middle Ch. / Freq.	Power High Ch. / Freq.	Tune-up limit (dBm)	MPR (dB)
Channel				132072	132322	132572		
Frequency (MHz)				1720	1745	1770		
20	QPSK	1	0	22.56	22.50	22.48	24	0
20	QPSK	1	49	22.54	22.40	22.45		
20	QPSK	1	99	22.41	22.30	22.27		
20	QPSK	50	0	21.59	21.48	21.48	23	1
20	QPSK	50	24	21.57	21.48	21.47		
20	QPSK	50	50	21.51	21.41	21.39		
20	QPSK	100	0	21.55	21.44	21.44	23	1
20	16QAM	1	0	22.01	21.91	21.87		
20	16QAM	1	49	21.99	21.87	21.81		
20	16QAM	1	99	21.82	21.76	21.77	22	2
20	16QAM	50	0	20.71	20.62	20.58		
20	16QAM	50	24	20.69	20.64	20.60		
20	16QAM	50	50	20.64	20.53	20.55	22	2
20	16QAM	100	0	20.69	20.55	20.56		
20	64QAM	1	0	20.94	20.80	20.80		
20	64QAM	1	49	20.89	20.74	20.72	22	2
20	64QAM	1	99	20.70	20.64	20.67		
20	64QAM	50	0	19.70	19.60	19.55		
20	64QAM	50	24	19.66	19.55	19.56	21	3
20	64QAM	50	50	19.61	19.50	19.50		
20	64QAM	100	0	19.68	19.55	19.60		
Channel				132047	132322	132597		
Frequency (MHz)				1717.5	1745	1772.5		
15	QPSK	1	0	22.51	22.45	22.40	24	0
15	QPSK	1	37	22.49	22.41	22.36		
15	QPSK	1	74	22.46	22.32	22.27		
15	QPSK	36	0	21.53	21.40	21.44	23	1
15	QPSK	36	20	21.53	21.42	21.45		
15	QPSK	36	39	21.47	21.39	21.39		
15	QPSK	75	0	21.52	21.44	21.36	23	1
15	16QAM	1	0	22.01	21.85	21.85		
15	16QAM	1	37	21.96	21.81	21.78		
15	16QAM	1	74	21.86	21.75	21.71	22	2
15	16QAM	36	0	20.68	20.58	20.57		
15	16QAM	36	20	20.68	20.58	20.54		
15	16QAM	36	39	20.62	20.50	20.52	22	2
15	16QAM	75	0	20.66	20.51	20.53		
15	64QAM	1	0	20.85	20.74	20.79		
15	64QAM	1	37	20.87	20.72	20.63	22	2
15	64QAM	1	74	20.76	20.61	20.60		
15	64QAM	36	0	19.69	19.57	19.54		
15	64QAM	36	20	19.66	19.57	19.57	21	3
15	64QAM	36	39	19.61	19.48	19.53		
15	64QAM	75	0	19.65	19.51	19.55		



Channel				132022	132322	132622	Tune-up limit (dBm)	MPR (dB)
Frequency (MHz)				1715	1745	1775		
10	QPSK	1	0	22.41	22.48	22.46	24	0
10	QPSK	1	25	22.40	22.42	22.43		
10	QPSK	1	49	22.47	22.34	22.33		
10	QPSK	25	0	21.59	21.47	21.42	23	1
10	QPSK	25	12	21.57	21.48	21.41		
10	QPSK	25	25	21.54	21.38	21.38		
10	QPSK	50	0	21.55	21.46	21.40		
10	16QAM	1	0	22.01	21.92	21.89	23	1
10	16QAM	1	25	21.99	21.85	21.83		
10	16QAM	1	49	21.87	21.82	21.75		
10	16QAM	25	0	20.70	20.62	20.58	22	2
10	16QAM	25	12	20.71	20.60	20.56		
10	16QAM	25	25	20.67	20.52	20.52		
10	16QAM	50	0	20.75	20.56	20.57		
10	64QAM	1	0	20.85	20.75	20.74	22	2
10	64QAM	1	25	20.88	20.77	20.67		
10	64QAM	1	49	20.82	20.66	20.64		
10	64QAM	25	0	19.70	19.60	19.56	21	3
10	64QAM	25	12	19.70	19.59	19.55		
10	64QAM	25	25	19.65	19.53	19.52		
10	64QAM	50	0	19.67	19.56	19.53		
Channel				131997	132322	132647	Tune-up limit (dBm)	MPR (dB)
Frequency (MHz)				1712.5	1745	1777.5		
5	QPSK	1	0	22.30	22.37	22.35	24	0
5	QPSK	1	12	22.21	22.21	22.32		
5	QPSK	1	24	22.26	22.23	22.23		
5	QPSK	12	0	21.45	21.36	21.31	23	1
5	QPSK	12	7	21.46	21.36	21.30		
5	QPSK	12	13	21.40	21.27	21.21		
5	QPSK	25	0	21.44	21.35	21.29		
5	16QAM	1	0	21.90	21.95	21.78	23	1
5	16QAM	1	12	21.87	21.74	21.68		
5	16QAM	1	24	21.76	21.71	21.64		
5	16QAM	12	0	20.56	20.65	20.65	22	2
5	16QAM	12	7	20.60	20.49	20.45		
5	16QAM	12	13	20.56	20.54	20.41		
5	16QAM	25	0	20.64	20.45	20.65		
5	64QAM	1	0	20.68	20.64	20.63	22	2
5	64QAM	1	12	20.77	20.58	20.56		
5	64QAM	1	24	20.56	20.55	20.51		
5	64QAM	12	0	19.59	19.49	19.45	21	3
5	64QAM	12	7	19.56	19.52	19.45		
5	64QAM	12	13	19.54	19.42	19.41		
5	64QAM	25	0	19.56	19.45	19.42		



Channel				131987	132322	132657	Tune-up limit (dBm)	MPR (dB)
Frequency (MHz)				1711.5	1745	1778.5		
3	QPSK	1	0	22.33	22.40	22.38	24	0
3	QPSK	1	8	22.32	22.34	22.35		
3	QPSK	1	14	22.39	22.26	22.25		
3	QPSK	8	0	21.51	21.39	21.34	23	1
3	QPSK	8	4	21.49	21.40	21.33		
3	QPSK	8	7	21.46	21.30	21.30		
3	QPSK	15	0	21.47	21.38	21.32	23	1
3	16QAM	1	0	21.93	21.84	21.81		
3	16QAM	1	8	21.91	21.77	21.75		
3	16QAM	1	14	21.79	21.74	21.67	22	2
3	16QAM	8	0	20.62	20.54	20.50		
3	16QAM	8	4	20.63	20.52	20.48		
3	16QAM	8	7	20.59	20.44	20.44	22	2
3	16QAM	15	0	20.67	20.48	20.49		
3	64QAM	1	0	20.77	20.67	20.66		
3	64QAM	1	8	20.80	20.69	20.59	22	2
3	64QAM	1	14	20.74	20.58	20.56		
3	64QAM	8	0	19.62	19.52	19.48		
3	64QAM	8	4	19.62	19.51	19.47	21	3
3	64QAM	8	7	19.57	19.45	19.44		
3	64QAM	15	0	19.59	19.48	19.45		
Channel				131979	132322	132665	Tune-up limit (dBm)	MPR (dB)
Frequency (MHz)				1710.7	1745	1779.3		
1.4	QPSK	1	0	22.33	22.35	22.38	24	0
1.4	QPSK	1	3	22.35	22.34	22.36		
1.4	QPSK	1	5	22.39	22.26	22.25		
1.4	QPSK	3	0	22.31	22.30	22.31		
1.4	QPSK	3	1	22.21	22.35	22.21		
1.4	QPSK	3	3	22.13	22.19	22.32	23	1
1.4	QPSK	6	0	21.47	21.38	21.32		
1.4	16QAM	1	0	21.99	21.84	21.78	23	1
1.4	16QAM	1	3	21.91	21.68	21.75		
1.4	16QAM	1	5	21.80	21.74	21.71		
1.4	16QAM	3	0	21.81	21.74	21.65		
1.4	16QAM	3	1	21.82	21.83	21.85		
1.4	16QAM	3	3	21.80	21.69	21.65	22	2
1.4	16QAM	6	0	20.70	20.48	20.49		
1.4	64QAM	1	0	20.77	20.56	20.72	22	2
1.4	64QAM	1	3	20.80	20.69	20.59		
1.4	64QAM	1	5	20.84	20.58	20.56		
1.4	64QAM	3	0	20.78	20.45	20.45		
1.4	64QAM	3	1	20.74	20.60	20.35		
1.4	64QAM	3	3	20.65	20.51	20.45	21	3
1.4	64QAM	6	0	19.61	19.48	19.45		



**<Reduced Power Mode for P-Sensor On/Hotspot On>**

**<LTE Band 2>**

BW [MHz]	Modulation	RB Size	RB Offset	Power Low Ch. / Freq.	Power Middle Ch. / Freq.	Power High Ch. / Freq.	Tune-up limit (dBm)	MPR (dB)
Channel				18700	18900	19100		
Frequency (MHz)				1860	1880	1900		
20	QPSK	1	0	15.06	15.42	15.02	16	0
20	QPSK	1	49	14.95	15.01	14.96		
20	QPSK	1	99	14.97	15.02	14.99		
20	QPSK	50	0	15.05	15.19	15.00	16	0
20	QPSK	50	24	14.80	14.95	14.82		
20	QPSK	50	50	14.92	14.88	14.81		
20	QPSK	100	0	14.93	15.10	14.83	16	0
20	16QAM	1	0	15.32	15.40	15.34		
20	16QAM	1	49	15.12	15.13	15.04		
20	16QAM	1	99	15.40	15.37	15.09	16	0
20	16QAM	50	0	14.96	15.06	15.00		
20	16QAM	50	24	14.94	15.01	14.95		
20	16QAM	50	50	14.97	15.02	14.95	16	0
20	16QAM	100	0	15.03	15.01	14.94		
20	64QAM	1	0	15.28	15.35	15.17		
20	64QAM	1	49	14.94	15.11	15.03	16	0
20	64QAM	1	99	15.24	15.26	15.01		
20	64QAM	50	0	15.00	15.07	15.01		
20	64QAM	50	24	14.94	15.02	14.98	16	0
20	64QAM	50	50	15.00	15.02	14.94		
20	64QAM	100	0	15.02	15.03	14.96		
Channel				18675	18900	19125	Tune-up limit (dBm)	MPR (dB)
Frequency (MHz)				1857.5	1880	1902.5		
15	QPSK	1	0	14.87	14.99	14.91	16	0
15	QPSK	1	37	14.72	14.80	14.73		
15	QPSK	1	74	14.74	14.87	14.83		
15	QPSK	36	0	14.83	14.93	14.90	16	0
15	QPSK	36	20	14.80	14.96	14.85		
15	QPSK	36	39	14.81	14.88	14.83		
15	QPSK	75	0	14.82	14.95	14.89	16	0
15	16QAM	1	0	15.17	15.34	15.29		
15	16QAM	1	37	15.08	15.13	15.11		
15	16QAM	1	74	15.07	15.21	15.20	16	0
15	16QAM	36	0	15.00	15.08	14.97		
15	16QAM	36	20	14.98	15.05	14.98		
15	16QAM	36	39	14.88	15.04	14.96	16	0
15	16QAM	75	0	14.90	15.01	14.95		
15	64QAM	1	0	15.09	15.25	15.23		
15	64QAM	1	37	15.01	15.13	15.08	16	0
15	64QAM	1	74	15.10	15.21	15.09		
15	64QAM	36	0	14.98	15.11	14.98		
15	64QAM	36	20	14.96	15.06	15.01	16	0
15	64QAM	36	39	14.90	15.07	14.95		
15	64QAM	75	0	14.93	15.02	14.98		



Channel				18650	18900	19150	Tune-up limit (dBm)	MPR (dB)
Frequency (MHz)				1855	1880	1905		
10	QPSK	1	0	15.07	15.14	14.89	16	0
10	QPSK	1	25	14.77	14.90	14.77		
10	QPSK	1	49	14.98	15.07	14.77		
10	QPSK	25	0	14.83	14.97	14.86	16	0
10	QPSK	25	12	14.87	14.94	14.87		
10	QPSK	25	25	14.79	14.94	14.82		
10	QPSK	50	0	14.84	14.93	14.88	16	0
10	16QAM	1	0	15.40	15.34	15.11		
10	16QAM	1	25	15.20	15.27	15.16		
10	16QAM	1	49	15.38	15.41	15.06	16	0
10	16QAM	25	0	14.96	15.06	14.96		
10	16QAM	25	12	14.95	15.06	14.98		
10	16QAM	25	25	14.91	15.06	14.94	16	0
10	16QAM	50	0	14.95	15.03	14.95		
10	64QAM	1	0	15.28	15.41	15.10		
10	64QAM	1	25	15.05	15.13	15.02	16	0
10	64QAM	1	49	15.30	15.37	15.07		
10	64QAM	25	0	14.98	15.07	15.01		
10	64QAM	25	12	14.99	15.10	14.96	16	0
10	64QAM	25	25	14.97	15.05	14.95		
10	64QAM	50	0	14.98	15.04	14.95		
Channel				18625	18900	19175	Tune-up limit (dBm)	MPR (dB)
Frequency (MHz)				1852.5	1880	1907.5		
5	QPSK	1	0	14.82	14.92	14.80	16	0
5	QPSK	1	12	14.78	14.86	14.77		
5	QPSK	1	24	14.78	14.87	14.76		
5	QPSK	12	0	14.85	14.93	14.87	16	0
5	QPSK	12	7	14.78	14.88	14.82		
5	QPSK	12	13	14.80	14.88	14.79		
5	QPSK	25	0	14.84	14.87	14.79	16	0
5	16QAM	1	0	15.16	15.19	15.15		
5	16QAM	1	12	15.06	15.15	15.09		
5	16QAM	1	24	15.08	15.19	15.17	16	0
5	16QAM	12	0	14.95	15.00	14.93		
5	16QAM	12	7	14.91	15.01	14.90		
5	16QAM	12	13	14.89	15.01	14.92	16	0
5	16QAM	25	0	14.90	15.02	14.93		
5	64QAM	1	0	15.11	15.24	15.09		
5	64QAM	1	12	14.99	15.08	15.06	16	0
5	64QAM	1	24	15.06	15.20	14.97		
5	64QAM	12	0	15.01	15.07	14.94		
5	64QAM	12	7	14.93	15.08	14.96	16	0
5	64QAM	12	13	14.99	15.06	14.96		
5	64QAM	25	0	14.94	15.03	14.91		



Channel				18615	18900	19185	Tune-up limit (dBm)	MPR (dB)
Frequency (MHz)				1851.5	1880	1908.5		
3	QPSK	1	0	14.77	14.85	14.74	16	0
3	QPSK	1	8	14.70	14.86	14.72		
3	QPSK	1	14	14.73	14.81	14.74		
3	QPSK	8	0	14.79	14.86	14.83	16	0
3	QPSK	8	4	14.78	14.93	14.77		
3	QPSK	8	7	14.75	14.85	14.76		
3	QPSK	15	0	14.77	14.85	14.74		
3	16QAM	1	0	15.10	15.26	15.13	16	0
3	16QAM	1	8	15.08	15.12	15.13		
3	16QAM	1	14	15.16	15.12	15.01		
3	16QAM	8	0	14.95	15.03	14.95	16	0
3	16QAM	8	4	14.94	15.05	15.00		
3	16QAM	8	7	14.96	15.03	14.91		
3	16QAM	15	0	14.92	14.93	14.90		
3	64QAM	1	0	15.02	15.15	15.01	16	0
3	64QAM	1	8	15.00	15.12	15.07		
3	64QAM	1	14	15.06	15.11	14.98		
3	64QAM	8	0	14.93	15.04	14.92	16	0
3	64QAM	8	4	14.93	15.02	14.96		
3	64QAM	8	7	14.90	14.99	14.88		
3	64QAM	15	0	14.88	14.98	14.87		
Channel				18607	18900	19193	Tune-up limit (dBm)	MPR (dB)
Frequency (MHz)				1850.7	1880	1909.3		
1.4	QPSK	1	0	14.68	14.72	14.65	16	0
1.4	QPSK	1	3	14.70	14.84	14.75		
1.4	QPSK	1	5	14.63	14.78	14.65		
1.4	QPSK	3	0	14.68	14.73	14.70		
1.4	QPSK	3	1	14.71	14.83	14.75		
1.4	QPSK	3	3	14.65	14.77	14.69		
1.4	QPSK	6	0	14.67	14.77	14.67	16	0
1.4	16QAM	1	0	15.09	15.12	14.98	16	0
1.4	16QAM	1	3	15.12	15.19	15.15		
1.4	16QAM	1	5	14.93	15.13	14.90		
1.4	16QAM	3	0	14.77	14.85	14.85		
1.4	16QAM	3	1	14.84	14.93	14.85		
1.4	16QAM	3	3	14.83	14.89	14.75		
1.4	16QAM	6	0	14.91	14.94	14.88	16	0
1.4	64QAM	1	0	15.00	15.05	14.89	16	0
1.4	64QAM	1	3	15.04	15.08	14.91		
1.4	64QAM	1	5	14.96	15.05	14.85		
1.4	64QAM	3	0	14.96	14.94	14.90		
1.4	64QAM	3	1	14.88	15.05	14.95		
1.4	64QAM	3	3	14.83	14.97	14.91		
1.4	64QAM	6	0	14.77	14.87	14.79	16	0



<LTE Band 4>

BW [MHz]	Modulation	RB Size	RB Offset	Power Low Ch. / Freq.	Power Middle Ch. / Freq.	Power High Ch. / Freq.	Tune-up limit (dBm)	MPR (dB)
Channel				20050	20175	20300		
Frequency (MHz)				1720	1732.5	1745		
20	QPSK	1	0	14.61	15.06	14.64	16	0
20	QPSK	1	49	14.63	14.64	14.58		
20	QPSK	1	99	14.60	14.60	14.59		
20	QPSK	50	0	14.62	14.93	14.69	16	0
20	QPSK	50	24	14.72	14.73	14.64		
20	QPSK	50	50	14.72	14.62	14.66		
20	QPSK	100	0	14.72	14.88	14.68	16	0
20	16QAM	1	0	14.89	14.88	15.01		
20	16QAM	1	49	15.04	15.03	14.95		
20	16QAM	1	99	14.98	15.00	15.02	16	0
20	16QAM	50	0	14.73	14.82	14.73		
20	16QAM	50	24	14.89	14.78	14.79		
20	16QAM	50	50	14.74	14.77	14.71	16	0
20	16QAM	100	0	14.80	14.79	14.70		
20	64QAM	1	0	14.85	14.83	14.93		
20	64QAM	1	49	14.93	14.96	14.82	16	0
20	64QAM	1	99	14.79	14.89	14.79		
20	64QAM	50	0	14.77	14.82	14.80		
20	64QAM	50	24	14.89	14.83	14.81	16	0
20	64QAM	50	50	14.85	14.77	14.74		
20	64QAM	100	0	14.82	14.78	14.73		
Channel				20025	20175	20325	Tune-up limit (dBm)	MPR (dB)
Frequency (MHz)				1717.5	1732.5	1747.5		
15	QPSK	1	0	14.60	14.71	14.63	16	0
15	QPSK	1	37	14.59	14.68	14.60		
15	QPSK	1	74	14.70	14.61	14.57		
15	QPSK	36	0	14.68	14.69	14.67	16	0
15	QPSK	36	20	14.68	14.71	14.68		
15	QPSK	36	39	14.73	14.67	14.65		
15	QPSK	75	0	14.75	14.68	14.66	16	0
15	16QAM	1	0	15.05	15.03	15.01		
15	16QAM	1	37	14.91	14.92	15.00		
15	16QAM	1	74	15.05	14.92	14.88	16	0
15	16QAM	36	0	14.76	14.74	14.73		
15	16QAM	36	20	14.77	14.85	14.82		
15	16QAM	36	39	14.84	14.78	14.79	16	0
15	16QAM	75	0	14.87	14.81	14.79		
15	64QAM	1	0	14.90	15.00	14.93		
15	64QAM	1	37	14.86	14.96	14.86	16	0
15	64QAM	1	74	14.93	14.78	14.91		
15	64QAM	36	0	14.82	14.83	14.78		
15	64QAM	36	20	14.85	14.86	14.83	16	0
15	64QAM	36	39	14.91	14.80	14.76		
15	64QAM	75	0	14.83	14.80	14.76		





Channel				20000	20175	20350	Tune-up limit (dBm)	MPR (dB)
Frequency (MHz)				1715	1732.5	1750		
10	QPSK	1	0	14.63	14.72	14.65	16	0
10	QPSK	1	25	14.59	14.67	14.62		
10	QPSK	1	49	14.58	14.60	14.61		
10	QPSK	25	0	14.60	14.67	14.62	16	0
10	QPSK	25	12	14.62	14.73	14.70		
10	QPSK	25	25	14.60	14.64	14.66		
10	QPSK	50	0	14.65	14.69	14.62	16	0
10	16QAM	1	0	14.98	14.98	15.02		
10	16QAM	1	25	14.89	15.03	14.92		
10	16QAM	1	49	14.98	14.94	14.98	16	0
10	16QAM	25	0	14.73	14.82	14.76		
10	16QAM	25	12	14.73	14.80	14.75		
10	16QAM	25	25	14.73	14.78	14.75	16	0
10	16QAM	50	0	14.75	14.76	14.77		
10	64QAM	1	0	14.95	15.02	14.88		
10	64QAM	1	25	14.87	15.01	14.83	16	0
10	64QAM	1	49	14.91	14.88	14.86		
10	64QAM	25	0	14.84	14.77	14.76		
10	64QAM	25	12	14.82	14.81	14.76	16	0
10	64QAM	25	25	14.75	14.78	14.72		
10	64QAM	50	0	14.79	14.83	14.77		
Channel				19975	20175	20375	Tune-up limit (dBm)	MPR (dB)
Frequency (MHz)				1712.5	1732.5	1752.5		
5	QPSK	1	0	14.61	14.66	14.61	16	0
5	QPSK	1	12	14.60	14.63	14.60		
5	QPSK	1	24	14.58	14.59	14.58		
5	QPSK	12	0	14.61	14.68	14.69	16	0
5	QPSK	12	7	14.62	14.66	14.67		
5	QPSK	12	13	14.65	14.63	14.61		
5	QPSK	25	0	14.60	14.68	14.62	16	0
5	16QAM	1	0	15.01	14.96	14.97		
5	16QAM	1	12	15.02	14.93	15.05		
5	16QAM	1	24	14.98	15.02	14.95	16	0
5	16QAM	12	0	14.74	14.76	14.72		
5	16QAM	12	7	14.80	14.82	14.77		
5	16QAM	12	13	14.76	14.77	14.74	16	0
5	16QAM	25	0	14.72	14.73	14.73		
5	64QAM	1	0	14.90	14.93	14.88		
5	64QAM	1	12	14.92	14.97	14.93	16	0
5	64QAM	1	24	14.91	14.93	14.89		
5	64QAM	12	0	14.83	14.85	14.84		
5	64QAM	12	7	14.84	14.82	14.86	16	0
5	64QAM	12	13	14.83	14.83	14.81		
5	64QAM	25	0	14.74	14.74	14.76		



Channel				19965	20175	20385	Tune-up limit (dBm)	MPR (dB)
Frequency (MHz)				1711.5	1732.5	1753.5		
3	QPSK	1	0	14.60	14.66	14.61	16	0
3	QPSK	1	8	14.59	14.65	14.62		
3	QPSK	1	14	14.62	14.62	14.62		
3	QPSK	8	0	14.64	14.68	14.61	16	0
3	QPSK	8	4	14.65	14.70	14.69		
3	QPSK	8	7	14.62	14.67	14.67		
3	QPSK	15	0	14.64	14.69	14.65		
3	16QAM	1	0	14.94	15.06	14.98	16	0
3	16QAM	1	8	15.05	15.01	15.04		
3	16QAM	1	14	14.83	14.91	14.88		
3	16QAM	8	0	14.78	14.87	14.82	16	0
3	16QAM	8	4	14.81	14.88	14.85		
3	16QAM	8	7	14.85	14.81	14.80		
3	16QAM	15	0	14.77	14.77	14.74		
3	64QAM	1	0	14.92	15.00	14.92	16	0
3	64QAM	1	8	15.01	14.91	14.93		
3	64QAM	1	14	14.99	14.94	14.93		
3	64QAM	8	0	14.80	14.83	14.80	16	0
3	64QAM	8	4	14.87	14.86	14.85		
3	64QAM	8	7	14.84	14.80	14.86		
3	64QAM	15	0	14.78	14.79	14.77		
Channel				19957	20175	20393	Tune-up limit (dBm)	MPR (dB)
Frequency (MHz)				1710.7	1732.5	1754.3		
1.4	QPSK	1	0	14.56	14.61	14.57	16	0
1.4	QPSK	1	3	14.62	14.66	14.64		
1.4	QPSK	1	5	14.54	14.59	14.59		
1.4	QPSK	3	0	14.63	14.63	14.63		
1.4	QPSK	3	1	14.66	14.67	14.65		
1.4	QPSK	3	3	14.64	14.64	14.64		
1.4	QPSK	6	0	14.59	14.63	14.58	16	0
1.4	16QAM	1	0	14.92	15.01	14.99	16	0
1.4	16QAM	1	3	15.06	15.02	15.00		
1.4	16QAM	1	5	14.91	15.04	14.90		
1.4	16QAM	3	0	14.78	14.74	14.78		
1.4	16QAM	3	1	14.79	14.76	14.72		
1.4	16QAM	3	3	14.72	14.74	14.74		
1.4	16QAM	6	0	14.82	14.83	14.82	16	0
1.4	64QAM	1	0	14.95	14.94	14.80	16	0
1.4	64QAM	1	3	15.00	14.97	15.00		
1.4	64QAM	1	5	14.92	14.97	14.88		
1.4	64QAM	3	0	14.85	14.87	14.78		
1.4	64QAM	3	1	14.91	14.87	14.96		
1.4	64QAM	3	3	14.87	14.85	14.79		
1.4	64QAM	6	0	14.78	14.74	14.63	16	0



<LTE Band 7>

BW [MHz]	Modulation	RB Size	RB Offset	Power Low Ch. / Freq.	Power Middle Ch. / Freq.	Power High Ch. / Freq.	Tune-up limit (dBm)	MPR (dB)
Channel				20850	21100	21350		
Frequency (MHz)				2510	2535	2560		
20	QPSK	1	0	17.54	17.55	17.58	19	0
20	QPSK	1	49	17.57	17.61	17.53		
20	QPSK	1	99	18.00	17.74	17.66		
20	QPSK	50	0	17.61	17.56	17.54	19	0
20	QPSK	50	24	17.66	17.60	17.54		
20	QPSK	50	50	17.97	17.89	17.75		
20	QPSK	100	0	17.88	17.74	17.70	19	0
20	16QAM	1	0	17.83	17.85	17.87		
20	16QAM	1	49	17.96	17.95	17.84		
20	16QAM	1	99	17.99	17.80	17.85	19	0
20	16QAM	50	0	17.70	17.69	17.62		
20	16QAM	50	24	17.71	17.75	17.66		
20	16QAM	50	50	17.71	17.67	17.57	19	0
20	16QAM	100	0	17.70	17.66	17.59		
20	64QAM	1	0	17.86	17.72	17.76		
20	64QAM	1	49	17.79	17.80	17.76	19	0
20	64QAM	1	99	17.82	17.64	17.63		
20	64QAM	50	0	17.70	17.65	17.58		
20	64QAM	50	24	17.72	17.77	17.57	19	0
20	64QAM	50	50	17.74	17.69	17.60		
20	64QAM	100	0	17.68	17.64	17.55		
Channel				20825	21100	21375	Tune-up limit (dBm)	MPR (dB)
Frequency (MHz)				2507.5	2535	2562.5		
15	QPSK	1	0	17.57	17.51	17.49	19	0
15	QPSK	1	37	17.41	17.57	17.45		
15	QPSK	1	74	17.55	17.46	17.38		
15	QPSK	36	0	17.58	17.59	17.52	19	0
15	QPSK	36	20	17.65	17.61	17.50		
15	QPSK	36	39	17.57	17.57	17.51		
15	QPSK	75	0	17.58	17.58	17.52	19	0
15	16QAM	1	0	17.92	17.96	17.86		
15	16QAM	1	37	17.88	17.91	17.86		
15	16QAM	1	74	17.99	17.83	17.78	19	0
15	16QAM	36	0	17.67	17.71	17.65		
15	16QAM	36	20	17.75	17.78	17.65		
15	16QAM	36	39	17.71	17.69	17.61	19	0
15	16QAM	75	0	17.72	17.71	17.63		
15	64QAM	1	0	17.79	17.88	17.72		
15	64QAM	1	37	17.86	17.84	17.82	19	0
15	64QAM	1	74	17.85	17.74	17.62		
15	64QAM	36	0	17.70	17.69	17.61		
15	64QAM	36	20	17.79	17.77	17.65	19	0
15	64QAM	36	39	17.74	17.70	17.58		
15	64QAM	75	0	17.72	17.68	17.57		



Channel				20800	21100	21400	Tune-up limit (dBm)	MPR (dB)
Frequency (MHz)				2505	2535	2565		
10	QPSK	1	0	17.61	17.58	17.47	19	0
10	QPSK	1	25	17.65	17.59	17.47		
10	QPSK	1	49	17.52	17.58	17.43		
10	QPSK	25	0	17.62	17.62	17.52	19	0
10	QPSK	25	12	17.64	17.60	17.51		
10	QPSK	25	25	17.65	17.62	17.51		
10	QPSK	50	0	17.63	17.65	17.54	19	0
10	16QAM	1	0	17.98	17.98	17.90		
10	16QAM	1	25	17.93	17.93	17.88		
10	16QAM	1	49	17.89	17.98	17.82	19	0
10	16QAM	25	0	17.72	17.73	17.67		
10	16QAM	25	12	17.75	17.78	17.66		
10	16QAM	25	25	17.77	17.73	17.60	19	0
10	16QAM	50	0	17.73	17.73	17.63		
10	64QAM	1	0	17.84	17.84	17.81		
10	64QAM	1	25	17.88	17.84	17.82	19	0
10	64QAM	1	49	17.78	17.79	17.77		
10	64QAM	25	0	17.73	17.73	17.64		
10	64QAM	25	12	17.78	17.75	17.65	19	0
10	64QAM	25	25	17.68	17.75	17.59		
10	64QAM	50	0	17.76	17.75	17.63		
Channel				20775	21100	21425	Tune-up limit (dBm)	MPR (dB)
Frequency (MHz)				2502.5	2535	2567.5		
5	QPSK	1	0	17.60	17.61	17.46	19	0
5	QPSK	1	12	17.63	17.63	17.52		
5	QPSK	1	24	17.58	17.60	17.48		
5	QPSK	12	0	17.62	17.65	17.54	19	0
5	QPSK	12	7	17.68	17.66	17.53		
5	QPSK	12	13	17.66	17.62	17.52		
5	QPSK	25	0	17.60	17.65	17.50	19	0
5	16QAM	1	0	17.96	17.95	17.76		
5	16QAM	1	12	17.94	17.92	17.90		
5	16QAM	1	24	17.93	17.92	17.82	19	0
5	16QAM	12	0	17.76	17.79	17.64		
5	16QAM	12	7	17.75	17.72	17.67		
5	16QAM	12	13	17.78	17.75	17.61	19	0
5	16QAM	25	0	17.72	17.73	17.62		
5	64QAM	1	0	17.86	17.93	17.81		
5	64QAM	1	12	17.80	17.90	17.75	19	0
5	64QAM	1	24	17.78	17.79	17.68		
5	64QAM	12	0	17.79	17.79	17.66		
5	64QAM	12	7	17.83	17.82	17.70	19	0
5	64QAM	12	13	17.84	17.78	17.64		
5	64QAM	25	0	17.74	17.74	17.61		



<LTE Band 66>

BW [MHz]	Modulation	RB Size	RB Offset	Power Low Ch. / Freq.	Power Middle Ch. / Freq.	Power High Ch. / Freq.	Tune-up limit (dBm)	MPR (dB)
Channel				132072	132322	132572		
Frequency (MHz)				1720	1745	1770		
20	QPSK	1	0	15.20	14.93	14.86	16	0
20	QPSK	1	49	14.79	14.73	14.78		
20	QPSK	1	99	14.85	14.75	14.76		
20	QPSK	50	0	15.05	14.89	14.85	16	0
20	QPSK	50	24	14.83	14.76	14.71		
20	QPSK	50	50	14.77	14.72	14.71		
20	QPSK	100	0	14.95	14.76	14.69	16	0
20	16QAM	1	0	15.14	15.15	15.01		
20	16QAM	1	49	15.17	15.02	14.97		
20	16QAM	1	99	15.08	15.08	15.03	16	0
20	16QAM	50	0	14.96	14.85	14.83		
20	16QAM	50	24	14.92	14.91	14.85		
20	16QAM	50	50	14.87	14.83	14.80	16	0
20	16QAM	100	0	14.91	14.81	14.78		
20	64QAM	1	0	15.11	14.92	14.90		
20	64QAM	1	49	15.05	15.00	15.00	16	0
20	64QAM	1	99	15.00	14.96	14.91		
20	64QAM	50	0	14.96	14.86	14.84		
20	64QAM	50	24	14.92	14.91	14.89	16	0
20	64QAM	50	50	14.88	14.84	14.85		
20	64QAM	100	0	14.92	14.84	14.81		
Channel				132047	132322	132597	Tune-up limit (dBm)	MPR (dB)
Frequency (MHz)				1717.5	1745	1772.5		
15	QPSK	1	0	14.78	14.69	14.65	16	0
15	QPSK	1	37	14.79	14.71	14.67		
15	QPSK	1	74	14.67	14.61	14.63		
15	QPSK	36	0	14.82	14.72	14.70	16	0
15	QPSK	36	20	14.83	14.76	14.76		
15	QPSK	36	39	14.78	14.73	14.69		
15	QPSK	75	0	14.80	14.73	14.75	16	0
15	16QAM	1	0	15.13	15.15	14.99		
15	16QAM	1	37	15.14	15.05	15.08		
15	16QAM	1	74	15.06	15.03	14.97	16	0
15	16QAM	36	0	14.91	14.83	14.85		
15	16QAM	36	20	14.96	14.84	14.83		
15	16QAM	36	39	14.89	14.80	14.77	16	0
15	16QAM	75	0	14.91	14.87	14.83		
15	64QAM	1	0	15.08	14.97	14.90		
15	64QAM	1	37	15.02	14.91	14.89	16	0
15	64QAM	1	74	14.94	14.88	14.89		
15	64QAM	36	0	14.97	14.88	14.83		
15	64QAM	36	20	14.99	14.85	14.89	16	0
15	64QAM	36	39	14.91	14.83	14.85		
15	64QAM	75	0	14.89	14.83	14.82		



Channel				132022	132322	132622	Tune-up limit (dBm)	MPR (dB)
Frequency (MHz)				1715	1745	1775		
10	QPSK	1	0	14.80	14.74	14.70	16	0
10	QPSK	1	25	14.83	14.72	14.75		
10	QPSK	1	49	14.79	14.70	14.73		
10	QPSK	25	0	14.88	14.76	14.77	16	0
10	QPSK	25	12	14.86	14.74	14.77		
10	QPSK	25	25	14.84	14.70	14.73		
10	QPSK	50	0	14.85	14.77	14.78		
10	16QAM	1	0	15.10	15.05	15.07	16	0
10	16QAM	1	25	15.08	15.02	15.16		
10	16QAM	1	49	15.12	15.05	15.14		
10	16QAM	25	0	14.95	14.90	14.88	16	0
10	16QAM	25	12	15.01	14.89	14.88		
10	16QAM	25	25	14.92	14.83	14.91		
10	16QAM	50	0	14.97	14.88	14.90		
10	64QAM	1	0	15.18	15.02	15.09	16	0
10	64QAM	1	25	15.14	15.02	15.02		
10	64QAM	1	49	15.08	15.03	15.01		
10	64QAM	25	0	15.03	14.89	14.88	16	0
10	64QAM	25	12	15.03	14.89	14.94		
10	64QAM	25	25	14.96	14.85	14.88		
10	64QAM	50	0	14.97	14.87	14.87		
Channel				131997	132322	132647	Tune-up limit (dBm)	MPR (dB)
Frequency (MHz)				1712.5	1745	1777.5		
5	QPSK	1	0	14.79	14.69	14.68	16	0
5	QPSK	1	12	14.84	14.72	14.75		
5	QPSK	1	24	14.77	14.65	14.67		
5	QPSK	12	0	14.85	14.72	14.74	16	0
5	QPSK	12	7	14.88	14.75	14.76		
5	QPSK	12	13	14.82	14.69	14.73		
5	QPSK	25	0	14.85	14.73	14.70		
5	16QAM	1	0	15.11	15.04	14.96	16	0
5	16QAM	1	12	15.19	15.08	15.01		
5	16QAM	1	24	15.19	15.11	15.06		
5	16QAM	12	0	14.94	14.88	14.81	16	0
5	16QAM	12	7	15.04	14.86	14.87		
5	16QAM	12	13	14.98	14.85	14.85		
5	16QAM	25	0	14.96	14.82	14.78		
5	64QAM	1	0	15.14	14.99	14.92	16	0
5	64QAM	1	12	15.12	14.95	14.99		
5	64QAM	1	24	15.10	14.95	14.94		
5	64QAM	12	0	15.00	14.89	14.85	16	0
5	64QAM	12	7	15.05	14.92	14.91		
5	64QAM	12	13	14.97	14.88	14.90		
5	64QAM	25	0	14.98	14.86	14.84		



Channel				131987	132322	132657	Tune-up limit (dBm)	MPR (dB)
Frequency (MHz)				1711.5	1745	1778.5		
3	QPSK	1	0	14.83	14.68	14.70	16	0
3	QPSK	1	8	14.80	14.75	14.69		
3	QPSK	1	14	14.81	14.69	14.72		
3	QPSK	8	0	14.86	14.76	14.75	16	0
3	QPSK	8	4	14.87	14.76	14.73		
3	QPSK	8	7	14.86	14.71	14.76		
3	QPSK	15	0	14.86	14.72	14.73		
3	16QAM	1	0	15.09	15.09	14.97	16	0
3	16QAM	1	8	15.12	15.06	15.07		
3	16QAM	1	14	15.18	14.99	15.06		
3	16QAM	8	0	15.02	14.90	14.89	16	0
3	16QAM	8	4	15.04	14.92	14.89		
3	16QAM	8	7	15.04	14.92	14.90		
3	16QAM	15	0	14.99	14.90	14.85		
3	64QAM	1	0	15.07	15.07	14.89	16	0
3	64QAM	1	8	15.13	15.06	15.07		
3	64QAM	1	14	15.10	15.05	15.00		
3	64QAM	8	0	15.05	14.92	14.91	16	0
3	64QAM	8	4	15.06	14.94	14.89		
3	64QAM	8	7	14.97	14.89	14.86		
3	64QAM	15	0	14.95	14.88	14.88		
Channel				131979	132322	132665	Tune-up limit (dBm)	MPR (dB)
Frequency (MHz)				1710.7	1745	1779.3		
1.4	QPSK	1	0	14.77	14.66	14.64	16	0
1.4	QPSK	1	3	14.88	14.72	14.72		
1.4	QPSK	1	5	14.75	14.63	14.67		
1.4	QPSK	3	0	14.83	14.68	14.69		
1.4	QPSK	3	1	14.84	14.73	14.70		
1.4	QPSK	3	3	14.81	14.69	14.70		
1.4	QPSK	6	0	14.79	14.69	14.69	16	0
1.4	16QAM	1	0	15.17	15.06	15.05	16	0
1.4	16QAM	1	3	15.11	15.03	15.18		
1.4	16QAM	1	5	15.14	14.97	15.05		
1.4	16QAM	3	0	15.00	14.82	14.84		
1.4	16QAM	3	1	14.88	14.87	14.82		
1.4	16QAM	3	3	14.98	14.76	14.81	16	0
1.4	16QAM	6	0	15.00	14.89	14.88	16	0
1.4	64QAM	1	0	15.12	14.99	14.93	16	0
1.4	64QAM	1	3	15.17	15.10	15.05		
1.4	64QAM	1	5	15.10	14.88	14.85		
1.4	64QAM	3	0	15.08	14.96	14.91		
1.4	64QAM	3	1	15.09	14.98	14.94		
1.4	64QAM	3	3	15.06	14.98	14.93		
1.4	64QAM	6	0	14.93	14.83	14.79	16	0



<Reduced Power Mode for Handheld On>

<LTE Band 2>

BW [MHz]	Modulation	RB Size	RB Offset	Power Low Ch. / Freq.	Power Middle Ch. / Freq.	Power High Ch. / Freq.	Tune-up limit (dBm)	MPR (dB)
Channel				18700	18900	19100		
Frequency (MHz)				1860	1880	1900		
20	QPSK	1	0	19.86	19.93	19.67	21	0
20	QPSK	1	49	19.45	19.48	19.46		
20	QPSK	1	99	19.47	19.51	19.45		
20	QPSK	50	0	19.30	19.66	19.39	21	0
20	QPSK	50	24	19.31	19.41	19.39		
20	QPSK	50	50	19.39	19.40	19.32		
20	QPSK	100	0	19.45	19.60	19.37		
20	16QAM	1	0	19.88	19.89	19.79	21	0
20	16QAM	1	49	19.62	19.77	19.67		
20	16QAM	1	99	19.79	19.90	19.66		
20	16QAM	50	0	19.46	19.57	19.49	21	0
20	16QAM	50	24	19.43	19.54	19.46		
20	16QAM	50	50	19.50	19.52	19.43		
20	16QAM	100	0	19.49	19.55	19.43		
20	64QAM	1	0	19.86	19.92	19.78	21	0
20	64QAM	1	49	19.48	19.63	19.66		
20	64QAM	1	99	19.86	19.84	19.60		
20	64QAM	50	0	19.48	19.62	19.55	21	0
20	64QAM	50	24	19.43	19.59	19.51		
20	64QAM	50	50	19.55	19.56	19.51		
20	64QAM	100	0	19.53	19.55	19.55		
Channel				18675	18900	19125	Tune-up limit (dBm)	MPR (dB)
Frequency (MHz)				1857.5	1880	1902.5		
15	QPSK	1	0	19.36	19.47	19.42	21	0
15	QPSK	1	37	19.24	19.41	19.30		
15	QPSK	1	74	19.27	19.41	19.36		
15	QPSK	36	0	19.33	19.46	19.37	21	0
15	QPSK	36	20	19.31	19.48	19.40		
15	QPSK	36	39	19.32	19.42	19.37		
15	QPSK	75	0	19.33	19.43	19.36		
15	16QAM	1	0	19.75	19.81	19.74	21	0
15	16QAM	1	37	19.60	19.79	19.63		
15	16QAM	1	74	19.74	19.70	19.74		
15	16QAM	36	0	19.47	19.55	19.47	21	0
15	16QAM	36	20	19.46	19.56	19.47		
15	16QAM	36	39	19.43	19.55	19.41		
15	16QAM	75	0	19.42	19.52	19.48		
15	64QAM	1	0	19.78	19.88	19.73	21	0
15	64QAM	1	37	19.62	19.64	19.62		
15	64QAM	1	74	19.63	19.71	19.67		
15	64QAM	36	0	19.59	19.60	19.56	21	0
15	64QAM	36	20	19.49	19.61	19.56		
15	64QAM	36	39	19.47	19.57	19.49		
15	64QAM	75	0	19.47	19.57	19.51		





Channel				18650	18900	19150	Tune-up limit (dBm)	MPR (dB)
Frequency (MHz)				1855	1880	1905		
10	QPSK	1	0	19.50	19.61	19.35	21	0
10	QPSK	1	25	19.24	19.39	19.25		
10	QPSK	1	49	19.47	19.59	19.28		
10	QPSK	25	0	19.31	19.42	19.31	21	0
10	QPSK	25	12	19.28	19.44	19.35		
10	QPSK	25	25	19.28	19.43	19.27		
10	QPSK	50	0	19.30	19.43	19.32	21	0
10	16QAM	1	0	19.90	19.84	19.74		
10	16QAM	1	25	19.67	19.79	19.61		
10	16QAM	1	49	19.89	19.82	19.60	21	0
10	16QAM	25	0	19.40	19.56	19.45		
10	16QAM	25	12	19.40	19.52	19.44		
10	16QAM	25	25	19.42	19.51	19.42	21	0
10	16QAM	50	0	19.41	19.54	19.42		
10	64QAM	1	0	19.82	19.86	19.59		
10	64QAM	1	25	19.68	19.60	19.60	21	0
10	64QAM	1	49	19.83	19.84	19.52		
10	64QAM	25	0	19.52	19.55	19.49		
10	64QAM	25	12	19.47	19.56	19.46	21	0
10	64QAM	25	25	19.45	19.55	19.44		
10	64QAM	50	0	19.49	19.58	19.44		
Channel				18625	18900	19175	Tune-up limit (dBm)	MPR (dB)
Frequency (MHz)				1852.5	1880	1907.5		
5	QPSK	1	0	19.32	19.39	19.32	21	0
5	QPSK	1	12	19.23	19.34	19.23		
5	QPSK	1	24	19.23	19.35	19.24		
5	QPSK	12	0	19.31	19.37	19.30	21	0
5	QPSK	12	7	19.31	19.38	19.36		
5	QPSK	12	13	19.30	19.35	19.31		
5	QPSK	25	0	19.28	19.38	19.29	21	0
5	16QAM	1	0	19.69	19.77	19.67		
5	16QAM	1	12	19.56	19.68	19.59		
5	16QAM	1	24	19.65	19.74	19.59	21	0
5	16QAM	12	0	19.43	19.46	19.41		
5	16QAM	12	7	19.35	19.48	19.41		
5	16QAM	12	13	19.42	19.47	19.39	21	0
5	16QAM	25	0	19.32	19.44	19.42		
5	64QAM	1	0	19.58	19.73	19.62		
5	64QAM	1	12	19.58	19.73	19.66	21	0
5	64QAM	1	24	19.56	19.65	19.52		
5	64QAM	12	0	19.48	19.59	19.48		
5	64QAM	12	7	19.48	19.55	19.48	21	0
5	64QAM	12	13	19.49	19.54	19.47		
5	64QAM	25	0	19.42	19.52	19.41		



Channel				18615	18900	19185	Tune-up limit (dBm)	MPR (dB)
Frequency (MHz)				1851.5	1880	1908.5		
3	QPSK	1	0	19.22	19.35	19.26	21	0
3	QPSK	1	8	19.18	19.31	19.21		
3	QPSK	1	14	19.19	19.27	19.21		
3	QPSK	8	0	19.25	19.37	19.28	21	0
3	QPSK	8	4	19.28	19.39	19.27		
3	QPSK	8	7	19.24	19.32	19.28		
3	QPSK	15	0	19.21	19.32	19.25	21	0
3	16QAM	1	0	19.59	19.75	19.61		
3	16QAM	1	8	19.53	19.61	19.61		
3	16QAM	1	14	19.62	19.69	19.56	21	0
3	16QAM	8	0	19.41	19.52	19.45		
3	16QAM	8	4	19.42	19.52	19.45		
3	16QAM	8	7	19.40	19.47	19.40	21	0
3	16QAM	15	0	19.34	19.38	19.40		
3	64QAM	1	0	19.52	19.66	19.58		
3	64QAM	1	8	19.58	19.64	19.54	21	0
3	64QAM	1	14	19.46	19.64	19.59		
3	64QAM	8	0	19.45	19.50	19.46		
3	64QAM	8	4	19.47	19.54	19.46	21	0
3	64QAM	8	7	19.47	19.50	19.46		
3	64QAM	15	0	19.36	19.42	19.41		
Channel				18607	18900	19193	Tune-up limit (dBm)	MPR (dB)
Frequency (MHz)				1850.7	1880	1909.3		
1.4	QPSK	1	0	19.18	19.28	19.18	21	0
1.4	QPSK	1	3	19.21	19.35	19.22		
1.4	QPSK	1	5	19.12	19.23	19.16		
1.4	QPSK	3	0	19.19	19.33	19.24		
1.4	QPSK	3	1	19.20	19.32	19.27		
1.4	QPSK	3	3	19.15	19.28	19.24	21	0
1.4	QPSK	6	0	19.17	19.30	19.21		
1.4	16QAM	1	0	19.49	19.70	19.46	21	0
1.4	16QAM	1	3	19.57	19.77	19.57		
1.4	16QAM	1	5	19.62	19.68	19.49		
1.4	16QAM	3	0	19.34	19.32	19.26		
1.4	16QAM	3	1	19.37	19.45	19.39		
1.4	16QAM	3	3	19.29	19.43	19.30	21	0
1.4	16QAM	6	0	19.33	19.51	19.40		
1.4	64QAM	1	0	19.52	19.60	19.54	21	0
1.4	64QAM	1	3	19.46	19.56	19.56		
1.4	64QAM	1	5	19.49	19.57	19.52		
1.4	64QAM	3	0	19.48	19.51	19.46		
1.4	64QAM	3	1	19.49	19.57	19.50		
1.4	64QAM	3	3	19.46	19.52	19.47	21	0
1.4	64QAM	6	0	19.30	19.39	19.30		



<LTE Band 4>

BW [MHz]	Modulation	RB Size	RB Offset	Power Low Ch. / Freq.	Power Middle Ch. / Freq.	Power High Ch. / Freq.	Tune-up limit (dBm)	MPR (dB)
Channel				20050	20175	20300		
Frequency (MHz)				1720	1732.5	1745		
20	QPSK	1	0	20.67	20.74	20.65	22	0
20	QPSK	1	49	20.81	21.13	20.83		
20	QPSK	1	99	20.66	20.65	20.67		
20	QPSK	50	0	20.65	20.76	20.64	22	0
20	QPSK	50	24	20.72	20.70	20.68		
20	QPSK	50	50	20.70	20.67	20.68		
20	QPSK	100	0	20.75	20.77	20.70	22	0
20	16QAM	1	0	21.09	21.08	21.08		
20	16QAM	1	49	21.11	21.03	21.10		
20	16QAM	1	99	21.11	21.03	21.04	22	0
20	16QAM	50	0	20.28	20.32	20.28		
20	16QAM	50	24	20.39	20.36	20.32		
20	16QAM	50	50	20.33	20.29	20.25	22	0
20	16QAM	100	0	20.37	20.28	20.26		
20	64QAM	1	0	20.45	20.47	20.47		
20	64QAM	1	49	20.55	20.56	20.47	22	0
20	64QAM	1	99	20.62	20.54	20.54		
20	64QAM	50	0	19.34	19.36	19.31		
20	64QAM	50	24	19.42	19.38	19.31	21	1
20	64QAM	50	50	19.37	19.29	19.30		
20	64QAM	100	0	19.40	19.30	19.31		
Channel				20025	20175	20325	Tune-up limit (dBm)	MPR (dB)
Frequency (MHz)				1717.5	1732.5	1747.5		
15	QPSK	1	0	20.65	20.71	20.65	22	0
15	QPSK	1	37	20.69	20.65	20.63		
15	QPSK	1	74	20.71	20.61	20.59		
15	QPSK	36	0	20.68	20.73	20.68	22	0
15	QPSK	36	20	20.66	20.74	20.67		
15	QPSK	36	39	20.77	20.65	20.64		
15	QPSK	75	0	20.77	20.69	20.65	22	0
15	16QAM	1	0	21.07	21.12	21.10		
15	16QAM	1	37	21.02	21.03	21.04		
15	16QAM	1	74	21.07	21.05	21.07	22	0
15	16QAM	36	0	20.32	20.31	20.26		
15	16QAM	36	20	20.32	20.38	20.31		
15	16QAM	36	39	20.36	20.28	20.25	22	0
15	16QAM	75	0	20.35	20.32	20.25		
15	64QAM	1	0	20.60	20.65	20.52		
15	64QAM	1	37	20.53	20.61	20.48	22	0
15	64QAM	1	74	20.53	20.48	20.44		
15	64QAM	36	0	19.36	19.39	19.29		
15	64QAM	36	20	19.37	19.36	19.35	21	1
15	64QAM	36	39	19.43	19.36	19.28		
15	64QAM	75	0	19.38	19.29	19.26		



Channel				20000	20175	20350	Tune-up limit (dBm)	MPR (dB)
Frequency (MHz)				1715	1732.5	1750		
10	QPSK	1	0	20.66	20.71	20.63	22	0
10	QPSK	1	25	20.69	20.65	20.60		
10	QPSK	1	49	20.63	20.62	20.63		
10	QPSK	25	0	20.63	20.70	20.63	22	0
10	QPSK	25	12	20.63	20.68	20.71		
10	QPSK	25	25	20.61	20.66	20.66		
10	QPSK	50	0	20.63	20.72	20.62	22	0
10	16QAM	1	0	21.06	21.06	21.05		
10	16QAM	1	25	21.04	21.10	21.04		
10	16QAM	1	49	20.99	21.03	21.08	22	0
10	16QAM	25	0	20.30	20.35	20.27		
10	16QAM	25	12	20.30	20.29	20.29		
10	16QAM	25	25	20.27	20.25	20.23	22	0
10	16QAM	50	0	20.30	20.30	20.28		
10	64QAM	1	0	20.57	20.60	20.49		
10	64QAM	1	25	20.50	20.57	20.56	22	0
10	64QAM	1	49	20.39	20.50	20.46		
10	64QAM	25	0	19.33	19.35	19.29		
10	64QAM	25	12	19.36	19.32	19.31	21	1
10	64QAM	25	25	19.31	19.28	19.29		
10	64QAM	50	0	19.26	19.32	19.25		
Channel				19975	20175	20375	Tune-up limit (dBm)	MPR (dB)
Frequency (MHz)				1712.5	1732.5	1752.5		
5	QPSK	1	0	20.63	20.62	20.63	22	0
5	QPSK	1	12	20.59	20.68	20.63		
5	QPSK	1	24	20.59	20.61	20.62		
5	QPSK	12	0	20.63	20.65	20.67	22	0
5	QPSK	12	7	20.67	20.72	20.70		
5	QPSK	12	13	20.66	20.66	20.66		
5	QPSK	25	0	20.62	20.63	20.62	22	0
5	16QAM	1	0	21.12	21.07	20.94		
5	16QAM	1	12	21.06	21.04	21.04		
5	16QAM	1	24	20.95	20.97	20.94	22	0
5	16QAM	12	0	20.31	20.32	20.29		
5	16QAM	12	7	20.37	20.36	20.35		
5	16QAM	12	13	20.29	20.30	20.27	22	0
5	16QAM	25	0	20.25	20.31	20.23		
5	64QAM	1	0	20.52	20.47	20.44		
5	64QAM	1	12	20.46	20.57	20.49	22	0
5	64QAM	1	24	20.45	20.41	20.44		
5	64QAM	12	0	19.38	19.35	19.33		
5	64QAM	12	7	19.39	19.36	19.33	21	1
5	64QAM	12	13	19.39	19.33	19.28		
5	64QAM	25	0	19.30	19.29	19.26		



Channel				19965	20175	20385	Tune-up limit (dBm)	MPR (dB)
Frequency (MHz)				1711.5	1732.5	1753.5		
3	QPSK	1	0	20.62	20.64	20.64	22	0
3	QPSK	1	8	20.58	20.65	20.65		
3	QPSK	1	14	20.60	20.64	20.60		
3	QPSK	8	0	20.69	20.71	20.66	22	0
3	QPSK	8	4	20.72	20.72	20.70		
3	QPSK	8	7	20.67	20.70	20.69		
3	QPSK	15	0	20.63	20.67	20.68		
3	16QAM	1	0	21.11	21.00	20.99		
3	16QAM	1	8	21.05	21.10	21.04	22	0
3	16QAM	1	14	21.09	21.12	21.02		
3	16QAM	8	0	20.37	20.34	20.32		
3	16QAM	8	4	20.43	20.39	20.36	22	0
3	16QAM	8	7	20.37	20.36	20.35		
3	16QAM	15	0	20.29	20.28	20.28		
3	64QAM	1	0	20.52	20.52	20.47		
3	64QAM	1	8	20.56	20.57	20.51		
3	64QAM	1	14	20.38	20.52	20.40	21	1
3	64QAM	8	0	19.42	19.38	19.32		
3	64QAM	8	4	19.43	19.42	19.38		
3	64QAM	8	7	19.42	19.36	19.31		
3	64QAM	15	0	19.31	19.34	19.28		
Channel				19957	20175	20393	Tune-up limit (dBm)	MPR (dB)
Frequency (MHz)				1710.7	1732.5	1754.3		
1.4	QPSK	1	0	20.58	20.60	20.55	22	0
1.4	QPSK	1	3	20.70	20.67	20.64		
1.4	QPSK	1	5	20.62	20.62	20.55		
1.4	QPSK	3	0	20.67	20.63	20.61		
1.4	QPSK	3	1	20.68	20.71	20.66		
1.4	QPSK	3	3	20.67	20.64	20.62		
1.4	QPSK	6	0	20.62	20.65	20.65	22	0
1.4	16QAM	1	0	21.10	20.96	21.01	22	0
1.4	16QAM	1	3	21.00	21.05	21.09		
1.4	16QAM	1	5	21.11	20.93	21.00		
1.4	16QAM	3	0	20.77	20.81	20.78		
1.4	16QAM	3	1	20.87	20.80	20.83		
1.4	16QAM	3	3	20.77	20.75	20.80		
1.4	16QAM	6	0	20.34	20.38	20.32	22	0
1.4	64QAM	1	0	20.37	20.45	20.36	22	0
1.4	64QAM	1	3	20.63	20.53	20.48		
1.4	64QAM	1	5	20.31	20.46	20.39		
1.4	64QAM	3	0	20.44	20.42	20.40		
1.4	64QAM	3	1	20.46	20.46	20.43		
1.4	64QAM	3	3	20.49	20.39	20.35		
1.4	64QAM	6	0	19.27	19.25	19.24		



<LTE Band 7>

BW [MHz]	Modulation	RB Size	RB Offset	Power Low Ch. / Freq.	Power Middle Ch. / Freq.	Power High Ch. / Freq.	Tune-up limit (dBm)	MPR (dB)
Channel				20850	21100	21350		
Frequency (MHz)				2510	2535	2560		
20	QPSK	1	0	20.04	20.04	20.07	21.5	0
20	QPSK	1	49	20.06	20.13	20.05		
20	QPSK	1	99	20.50	20.14	20.19		
20	QPSK	50	0	20.09	20.09	20.03	21.5	0
20	QPSK	50	24	20.18	20.16	20.06		
20	QPSK	50	50	20.35	20.13	20.07		
20	QPSK	100	0	20.21	20.14	20.03	21.5	0
20	16QAM	1	0	20.34	20.43	20.29		
20	16QAM	1	49	20.32	20.49	20.44		
20	16QAM	1	99	20.33	20.27	20.30	21.5	0
20	16QAM	50	0	20.20	20.22	20.12		
20	16QAM	50	24	20.25	20.27	20.18		
20	16QAM	50	50	20.20	20.22	20.14	21.5	0
20	16QAM	100	0	20.22	20.20	20.11		
20	64QAM	1	0	20.40	20.44	20.30		
20	64QAM	1	49	20.39	20.37	20.35	21.5	0
20	64QAM	1	99	20.35	20.28	20.13		
20	64QAM	50	0	19.73	19.78	19.68		
20	64QAM	50	24	19.79	19.75	19.69	21	0.5
20	64QAM	50	50	19.75	19.71	19.62		
20	64QAM	100	0	19.72	19.70	19.62		
Channel				20825	21100	21375	Tune-up limit (dBm)	MPR (dB)
Frequency (MHz)				2507.5	2535	2562.5		
15	QPSK	1	0	20.07	20.06	19.97	21.5	0
15	QPSK	1	37	19.98	20.10	20.03		
15	QPSK	1	74	20.05	19.92	19.91		
15	QPSK	36	0	20.11	20.08	19.99	21.5	0
15	QPSK	36	20	20.15	20.12	20.05		
15	QPSK	36	39	20.10	20.07	19.97		
15	QPSK	75	0	20.13	20.07	19.97	21.5	0
15	16QAM	1	0	20.36	20.43	20.38		
15	16QAM	1	37	20.28	20.35	20.30		
15	16QAM	1	74	20.42	20.37	20.26	21.5	0
15	16QAM	36	0	20.18	20.21	20.12		
15	16QAM	36	20	20.22	20.24	20.22		
15	16QAM	36	39	20.24	20.21	20.13	21.5	0
15	16QAM	75	0	20.21	20.22	20.12		
15	64QAM	1	0	20.42	20.41	20.25		
15	64QAM	1	37	20.25	20.45	20.25	21.5	0
15	64QAM	1	74	20.42	20.26	20.23		
15	64QAM	36	0	19.75	19.72	19.65		
15	64QAM	36	20	19.75	19.74	19.67	21	0.5
15	64QAM	36	39	19.77	19.73	19.63		
15	64QAM	75	0	19.70	19.71	19.62		



Channel				20800	21100	21400	Tune-up limit (dBm)	MPR (dB)
Frequency (MHz)				2505	2535	2565		
10	QPSK	1	0	20.05	20.04	19.93	21.5	0
10	QPSK	1	25	20.12	20.07	20.00		
10	QPSK	1	49	19.94	19.99	19.88		
10	QPSK	25	0	20.11	20.09	20.00	21.5	0
10	QPSK	25	12	20.11	20.14	20.01		
10	QPSK	25	25	20.11	20.08	19.95		
10	QPSK	50	0	20.10	20.07	19.95	21.5	0
10	16QAM	1	0	20.35	20.37	20.28		
10	16QAM	1	25	20.45	20.36	20.40		
10	16QAM	1	49	20.29	20.35	20.33	21.5	0
10	16QAM	25	0	20.17	20.17	20.12		
10	16QAM	25	12	20.20	20.22	20.13		
10	16QAM	25	25	20.18	20.14	20.13	21.5	0
10	16QAM	50	0	20.17	20.23	20.14		
10	64QAM	1	0	20.30	20.38	20.29		
10	64QAM	1	25	20.45	20.46	20.31	21.5	0
10	64QAM	1	49	20.20	20.24	20.19		
10	64QAM	25	0	19.73	19.69	19.62		
10	64QAM	25	12	19.76	19.74	19.64	21	0.5
10	64QAM	25	25	19.70	19.72	19.59		
10	64QAM	50	0	19.75	19.72	19.62		
Channel				20775	21100	21425	Tune-up limit (dBm)	MPR (dB)
Frequency (MHz)				2502.5	2535	2567.5		
5	QPSK	1	0	20.06	20.03	19.97	21.5	0
5	QPSK	1	12	19.98	20.08	19.91		
5	QPSK	1	24	20.06	20.08	19.90		
5	QPSK	12	0	20.12	20.11	19.97	21.5	0
5	QPSK	12	7	20.12	20.14	20.02		
5	QPSK	12	13	20.11	20.13	19.96		
5	QPSK	25	0	20.10	20.09	19.97	21.5	0
5	16QAM	1	0	20.33	20.36	20.33		
5	16QAM	1	12	20.33	20.28	20.29		
5	16QAM	1	24	20.32	20.39	20.27	21.5	0
5	16QAM	12	0	20.16	20.15	20.13		
5	16QAM	12	7	20.20	20.23	20.18		
5	16QAM	12	13	20.19	20.19	20.14	21.5	0
5	16QAM	25	0	20.22	20.16	20.10		
5	64QAM	1	0	20.36	20.37	20.26		
5	64QAM	1	12	20.35	20.35	20.26	21.5	0
5	64QAM	1	24	20.38	20.28	20.27		
5	64QAM	12	0	19.74	19.75	19.67		
5	64QAM	12	7	19.76	19.83	19.72	21	0.5
5	64QAM	12	13	19.75	19.74	19.67		
5	64QAM	25	0	19.71	19.71	19.62		



<LTE Band 66>

BW [MHz]	Modulation	RB Size	RB Offset	Power Low Ch. / Freq.	Power Middle Ch. / Freq.	Power High Ch. / Freq.	Tune-up limit (dBm)	MPR (dB)
Channel				132072	132322	132572		
Frequency (MHz)				1720	1745	1770		
20	QPSK	1	0	21.25	21.11	21.03	22	0
20	QPSK	1	49	20.79	20.79	20.79		
20	QPSK	1	99	20.96	20.83	20.85		
20	QPSK	50	0	21.10	20.91	20.94	22	0
20	QPSK	50	24	20.84	20.75	20.74		
20	QPSK	50	50	20.74	20.74	20.72		
20	QPSK	100	0	21.08	20.96	20.91		
20	16QAM	1	0	21.23	21.18	21.19	22	0
20	16QAM	1	49	21.23	21.08	21.17		
20	16QAM	1	99	21.16	21.16	21.15		
20	16QAM	50	0	20.47	20.36	20.34	22	0
20	16QAM	50	24	20.45	20.39	20.40		
20	16QAM	50	50	20.37	20.34	20.34		
20	16QAM	100	0	20.37	20.38	20.33		
20	64QAM	1	0	20.66	20.51	20.62	22	0
20	64QAM	1	49	20.66	20.66	20.63		
20	64QAM	1	99	20.69	20.48	20.55		
20	64QAM	50	0	19.49	19.37	19.36	21	1
20	64QAM	50	24	19.52	19.42	19.42		
20	64QAM	50	50	19.42	19.37	19.39		
20	64QAM	100	0	19.45	19.39	19.39		
Channel				132047	132322	132597	Tune-up limit (dBm)	MPR (dB)
Frequency (MHz)				1717.5	1745	1772.5		
15	QPSK	1	0	20.82	20.68	20.67	22	0
15	QPSK	1	37	20.78	20.72	20.70		
15	QPSK	1	74	20.74	20.65	20.62		
15	QPSK	36	0	20.83	20.73	20.70	22	0
15	QPSK	36	20	20.81	20.75	20.73		
15	QPSK	36	39	20.78	20.71	20.71		
15	QPSK	75	0	20.84	20.71	20.72		
15	16QAM	1	0	21.24	21.07	21.06	22	0
15	16QAM	1	37	21.22	21.22	21.05		
15	16QAM	1	74	21.12	21.10	21.14		
15	16QAM	36	0	20.47	20.32	20.35	22	0
15	16QAM	36	20	20.49	20.39	20.39		
15	16QAM	36	39	20.42	20.30	20.36		
15	16QAM	75	0	20.40	20.36	20.34		
15	64QAM	1	0	20.67	20.56	20.59	22	0
15	64QAM	1	37	20.70	20.64	20.63		
15	64QAM	1	74	20.58	20.49	20.44		
15	64QAM	36	0	19.53	19.40	19.40	21	1
15	64QAM	36	20	19.57	19.37	19.43		
15	64QAM	36	39	19.48	19.34	19.44		
15	64QAM	75	0	19.44	19.36	19.38		





Channel				132022	132322	132622	Tune-up limit (dBm)	MPR (dB)
Frequency (MHz)				1715	1745	1775		
10	QPSK	1	0	20.83	20.73	20.77	22	0
10	QPSK	1	25	20.82	20.75	20.74		
10	QPSK	1	49	20.72	20.67	20.70		
10	QPSK	25	0	20.82	20.76	20.71	22	0
10	QPSK	25	12	20.82	20.76	20.72		
10	QPSK	25	25	20.80	20.72	20.73		
10	QPSK	50	0	20.81	20.71	20.73	22	0
10	16QAM	1	0	21.14	21.17	21.07		
10	16QAM	1	25	21.20	21.24	21.11		
10	16QAM	1	49	21.21	21.06	21.22	22	0
10	16QAM	25	0	20.47	20.38	20.40		
10	16QAM	25	12	20.49	20.41	20.42		
10	16QAM	25	25	20.50	20.33	20.36	22	0
10	16QAM	50	0	20.45	20.35	20.38		
10	64QAM	1	0	20.75	20.54	20.60		
10	64QAM	1	25	20.81	20.58	20.47	22	0
10	64QAM	1	49	20.59	20.58	20.58		
10	64QAM	25	0	19.49	19.39	19.41		
10	64QAM	25	12	19.51	19.40	19.42	21	1
10	64QAM	25	25	19.52	19.36	19.44		
10	64QAM	50	0	19.51	19.37	19.40		
Channel				131997	132322	132647	Tune-up limit (dBm)	MPR (dB)
Frequency (MHz)				1712.5	1745	1777.5		
5	QPSK	1	0	20.88	20.75	20.67	22	0
5	QPSK	1	12	20.88	20.72	20.79		
5	QPSK	1	24	20.81	20.65	20.63		
5	QPSK	12	0	20.88	20.75	20.78	22	0
5	QPSK	12	7	20.87	20.76	20.78		
5	QPSK	12	13	20.84	20.74	20.73		
5	QPSK	25	0	20.83	20.73	20.71	22	0
5	16QAM	1	0	21.14	21.08	21.12		
5	16QAM	1	12	21.20	21.12	21.21		
5	16QAM	1	24	21.13	21.07	21.15	22	0
5	16QAM	12	0	20.53	20.40	20.40		
5	16QAM	12	7	20.55	20.41	20.48		
5	16QAM	12	13	20.54	20.38	20.38	22	0
5	16QAM	25	0	20.49	20.39	20.39		
5	64QAM	1	0	20.67	20.49	20.54		
5	64QAM	1	12	20.72	20.59	20.60	22	0
5	64QAM	1	24	20.69	20.48	20.46		
5	64QAM	12	0	19.58	19.46	19.47		
5	64QAM	12	7	19.69	19.47	19.52	21	1
5	64QAM	12	13	19.58	19.44	19.44		
5	64QAM	25	0	19.54	19.38	19.41		



Channel				131987	132322	132657	Tune-up limit (dBm)	MPR (dB)
Frequency (MHz)				1711.5	1745	1778.5		
3	QPSK	1	0	20.83	20.73	20.68	22	0
3	QPSK	1	8	20.86	20.71	20.76		
3	QPSK	1	14	20.72	20.70	20.72		
3	QPSK	8	0	20.85	20.74	20.78	22	0
3	QPSK	8	4	20.89	20.76	20.75		
3	QPSK	8	7	20.87	20.74	20.72		
3	QPSK	15	0	20.83	20.74	20.71	22	0
3	16QAM	1	0	21.10	21.14	21.11		
3	16QAM	1	8	21.10	21.09	21.11		
3	16QAM	1	14	21.12	21.04	21.09	22	0
3	16QAM	8	0	20.60	20.41	20.42		
3	16QAM	8	4	20.62	20.45	20.49		
3	16QAM	8	7	20.60	20.45	20.43	22	0
3	16QAM	15	0	20.49	20.35	20.39		
3	64QAM	1	0	20.64	20.45	20.60		
3	64QAM	1	8	20.67	20.64	20.61	22	0
3	64QAM	1	14	20.62	20.65	20.46		
3	64QAM	8	0	19.60	19.42	19.47		
3	64QAM	8	4	19.67	19.46	19.51	21	1
3	64QAM	8	7	19.60	19.41	19.44		
3	64QAM	15	0	19.52	19.38	19.34		
Channel				131979	132322	132665	Tune-up limit (dBm)	MPR (dB)
Frequency (MHz)				1710.7	1745	1779.3		
1.4	QPSK	1	0	20.75	20.62	20.61	22	0
1.4	QPSK	1	3	20.76	20.71	20.69		
1.4	QPSK	1	5	20.76	20.67	20.67		
1.4	QPSK	3	0	20.82	20.66	20.70		
1.4	QPSK	3	1	20.83	20.74	20.70		
1.4	QPSK	3	3	20.81	20.70	20.72		
1.4	QPSK	6	0	20.79	20.69	20.69	22	0
1.4	16QAM	1	0	21.18	21.04	21.09	22	0
1.4	16QAM	1	3	21.18	21.10	21.14		
1.4	16QAM	1	5	21.19	21.15	20.98		
1.4	16QAM	3	0	20.96	20.89	20.86		
1.4	16QAM	3	1	21.04	20.87	20.85		
1.4	16QAM	3	3	21.03	20.86	20.83		
1.4	16QAM	6	0	20.54	20.39	20.38	22	0
1.4	64QAM	1	0	20.64	20.50	20.47	22	0
1.4	64QAM	1	3	20.71	20.57	20.57		
1.4	64QAM	1	5	20.69	20.49	20.53		
1.4	64QAM	3	0	20.58	20.51	20.50		
1.4	64QAM	3	1	20.72	20.47	20.60		
1.4	64QAM	3	3	20.60	20.48	20.50		
1.4	64QAM	6	0	19.40	19.35	19.35	21	1

### <WLAN Conducted Power>

#### General Note:

1. Per KDB 248227 D01v02r02, SAR test reduction is determined according to 802.11 transmission mode configurations and certain exposure conditions with multiple test positions. In the 2.4 GHz band, separate SAR procedures are applied to DSSS and OFDM configurations to simplify DSSS test requirements. For OFDM, in both 2.4 and 5 GHz bands, an initial test configuration must be determined for each standalone and aggregated frequency band, according to the transmission mode configuration with the highest maximum output power specified for production units to perform SAR measurements. If the same highest maximum output power applies to different combinations of channel bandwidths, modulations and data rates, additional procedures are applied to determine which test configurations require SAR measurement. When applicable, an initial test position may be applied to reduce the number of SAR measurements required for next to the ear, UMPC mini-tablet or hotspot mode configurations with multiple test positions.
2. For 2.4 GHz 802.11b DSSS, either the initial test position procedure for multiple exposure test positions or the DSSS procedure for fixed exposure position is applied; these are mutually exclusive. For 2.4 GHz and 5 GHz OFDM configurations, the initial test configuration is applied to measure SAR using either the initial test position procedure for multiple exposure test position configurations or the initial test configuration procedures for fixed exposure test conditions. Based on the reported SAR of the measured configurations and maximum output power of the transmission mode configurations that are not included in the initial test configuration, the subsequent test configuration and initial test position procedures are applied to determine if SAR measurements are required for the remaining OFDM transmission configurations. In general, the number of test channels that require SAR measurement is minimized based on maximum output power measured for the test sample(s).
3. For OFDM transmission configurations in the 2.4 GHz and 5 GHz bands, When the same maximum power is specified for multiple transmission modes in a frequency band, the largest channel bandwidth, lowest order modulation, lowest data rate and lowest order 802.11a/g/n/ac mode is used for SAR measurement, on the highest measured output power channel for each frequency band.
4. DSSS and OFDM configurations are considered separately according to the required SAR procedures. SAR is measured in the initial test position using the 802.11 transmission mode configuration required by the DSSS procedure or initial test configuration and subsequent test configuration(s) according to the OFDM procedures.18 The initial test position procedure is described in the following:
  - a. When the reported SAR of the initial test position is  $\leq 0.4$  W/kg, further SAR measurement is not required for the other test positions in that exposure configuration and 802.11 transmission mode combinations within the frequency band or aggregated band.
  - b. When the reported SAR of the test position is  $> 0.4$  W/kg, SAR is repeated for the 802.11 transmission mode configuration tested in the initial test position to measure the subsequent next closet/smallest test separation distance and maximum coupling test position on the highest maximum output power channel, until the report SAR is  $\leq 0.8$  W/kg or all required test position are tested.
  - c. For all positions/configurations, when the reported SAR is  $> 0.8$  W/kg, SAR is measured for these test positions/configurations on the subsequent next highest measured output power channel(s) until the reported SAR is  $\leq 1.2$  W/kg or all required channels are tested.



<2.4GHz WLAN>

	Mode	Channel	Frequency (MHz)	Average power (dBm)	Tune-Up Limit	Duty Cycle %
2.4GHz WLAN	802.11b 1Mbps	1	2412	18.93	19.50	98.63
		6	2437	17.82	19.50	
		11	2462	18.69	19.50	
	802.11g 6Mbps	1	2412	17.08	18.00	97.46
		6	2437	16.54	18.00	
		11	2462	14.40	16.00	
	802.11n-HT20 MCS0	1	2412	16.16	17.00	97.30
		6	2437	15.60	17.00	
		11	2462	13.23	15.00	

<2.4GHz Bluetooth>

General Note:

1. For 2.4GHz Bluetooth SAR testing was selected 1Mbps, due to its highest average power.
2. The Bluetooth duty cycle is 77.36 % as following figure, according to 2016 Oct. TCB workshop for Bluetooth SAR scaling need further consideration and the theoretical duty cycle is 83.3%, therefore the actual duty cycle will be scaled up to the theoretical value of Bluetooth reported SAR calculation

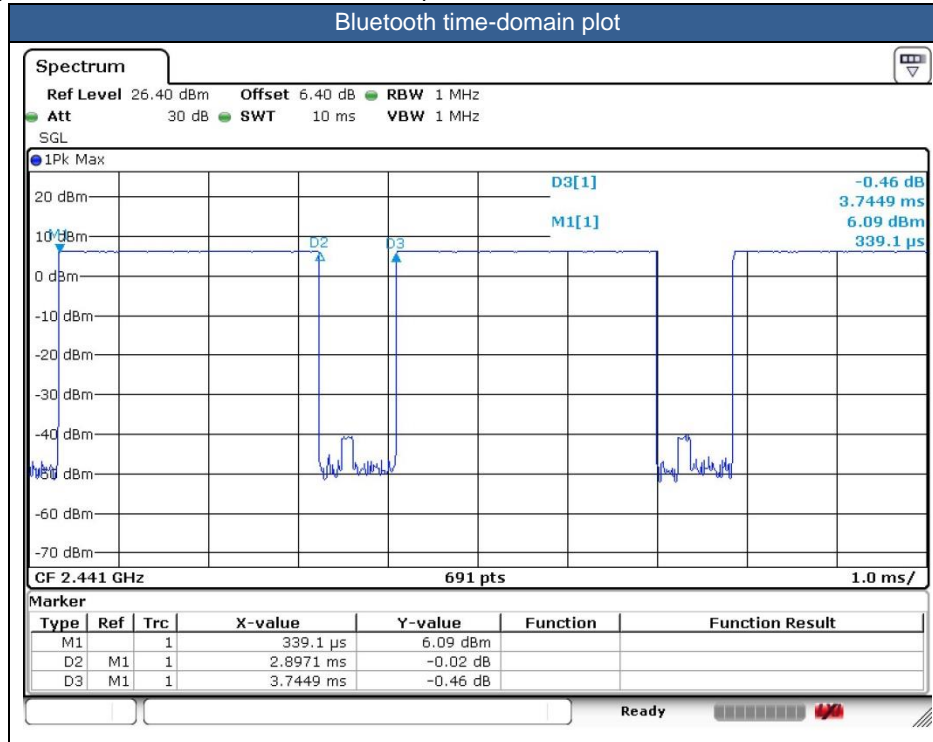

Mode	Channel	Frequency (MHz)	Average power (dBm)
			1Mbps
BR/EDR	CH 00	2402	6.17
	CH 39	2441	5.38
	CH 78	2480	<b>7.06</b>
Tune-up limit (dBm)			8.00

Mode	Channel	Frequency (MHz)	Average power (dBm)
			GFSK
v4.0/5.0 LE	CH 00	2402	<b>2.10</b>
	CH 19	2440	0.54
	CH 39	2480	1.35
Tune-up Limit			3.00

### 14. Antenna Location

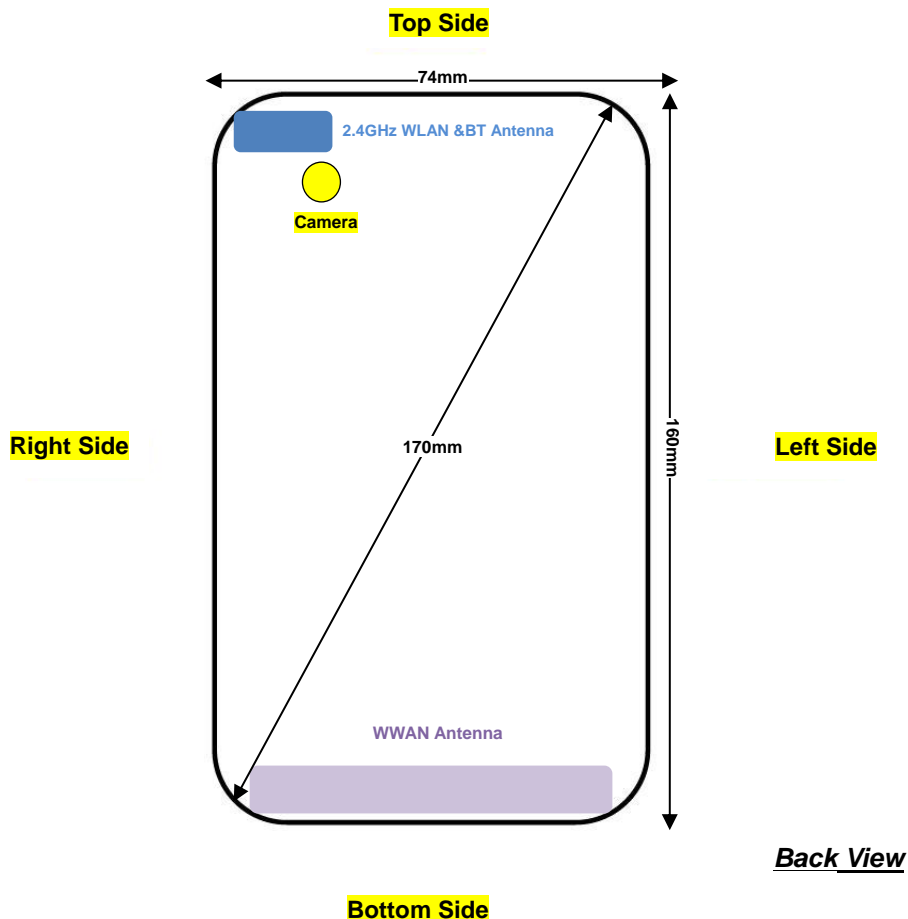

Distance of the Antenna to the EUT surface/edge						
Antennas	Back	Front	Top Side	Bottom Side	Right Side	Left Side
WWAN Antenna	≤ 25mm	≤ 25mm	>25mm	≤ 25mm	≤ 25mm	≤ 25mm
2.4GHz WLAN & BT	≤ 25mm	≤ 25mm	≤ 25mm	>25mm	≤ 25mm	>25mm

Positions for SAR tests; Hotspot mode						
Antennas	Back	Front	Top Side	Bottom Side	Right Side	Left Side
WWAN Antenna	Yes	Yes	No	Yes	Yes	Yes
2.4GHz WLAN & BT	Yes	Yes	Yes	No	Yes	No

**General Note:**

- Referring to KDB 941225 D06 v02r01, when the overall device length and width are ≥ 9cm\*5cm, the test distance is 10 mm. SAR must be measured for all sides and surfaces with a transmitting antenna located within 25mm from that surface or edge.

## 15. SAR Test Results

### General Note:

1. Per KDB 447498 D01v06, the reported SAR is the measured SAR value adjusted for maximum tune-up tolerance.
  - a. Tune-up scaling Factor = tune-up limit power (mW) / EUT RF power (mW), where tune-up limit is the maximum rated power among all production units.
  - b. For SAR testing of WLAN signal with non-100% duty cycle, the measured SAR is scaled-up by the duty cycle scaling factor which is equal to "1/(duty cycle)"
  - c. For WWAN: Reported SAR(W/kg)= Measured SAR(W/kg)\*Tune-up Scaling Factor
  - d. For BT/WLAN: Reported SAR(W/kg)= Measured SAR(W/kg)\* Duty Cycle scaling factor \* Tune-up scaling factor
2. Per KDB 447498 D01v06, for each exposure position, testing of other required channels within the operating mode of a frequency band is not required when the *reported* 1-g or 10-g SAR for the mid-band or highest output power channel is:
  - $\leq 0.8$  W/kg or 2.0 W/kg, for 1-g or 10-g respectively, when the transmission band is  $\leq 100$  MHz
  - $\leq 0.6$  W/kg or 1.5 W/kg, for 1-g or 10-g respectively, when the transmission band is between 100 MHz and 200 MHz
  - $\leq 0.4$  W/kg or 1.0 W/kg, for 1-g or 10-g respectively, when the transmission band is  $\geq 200$  MHz
3. Per KDB 865664 D01v01r04, for each frequency band, repeated SAR measurement is required when the measured SAR is  $\geq 0.8$ W/kg. Per KDB 865664 D01v01r04, if the extremity repeated SAR is necessary, the same procedures should be adapted for measurements according to extremity and occupational exposure limits by applying a factor of 2.5 for extremity exposure and a factor of 5 for occupational exposure to the corresponding SAR thresholds.
4. Per KDB648474 D04v01r03, when the reported SAR for a body-worn accessory, measured without a headset connected to the handset, is  $> 1.2$  W/kg, the highest reported SAR configuration for that wireless mode and frequency band should be repeated for that body-worn accessory with a headset attached to the handset. When headset SAR is less than or equal than without headset SAR, no need to verify the remaining channels for headset SAR.
5. The device employs proximity sensors that detect the presence of the user's body at the front or back faces of the device. When front or back body worn condition is detected, GSM850/1900, WCDMA band II/IV/V and LTE band 2/4/7/66 reduced power will be active. (P-sensor can't work at detecting presence of the user's body at the four edges of the device.)
6. P-sensor can detect handheld state, WCDMA band II/IV, and LTE band 2/4/7/66 for front/back/bottom sides of product specific 10g SAR condition reduced powers will be active.
7. When hotspot mode is enabled, power reduction will be activated to limit the maximum power of GSM850/1900, WCDMA band II/IV/V and LTE band 2/4/7/66.
8. Per KDB648474 D04v01r03, for smart phones with a display diagonal dimension  $> 15.0$  cm or an overall diagonal dimension  $> 16.0$  cm, when hotspot mode applies, 10-g extremity SAR is required only for the surfaces and edges with hotspot mode 1-g reported SAR  $> 1.2$  W/kg, however, when power reduction applies to hotspot mode the measured SAR must be scaled to the maximum output power (for handheld on state, the maximum full power means reduced power), including tolerance, allowed for phablet modes to compare with the 1.2 W/kg SAR test reduction threshold.
  - a. For this device SAR for WWAN transmitter scaled to maximum output power mode for product specific 10g SAR is higher than 1.2W/kg of GSM850/1900, WCDMA band II/IV/V, LTE Band 2/4/7/66, therefore product specific 10g SAR is necessary.
  - b. When 10-g product specific 10g SAR is considered, SAR thresholds is specified in the procedures for SAR test reduction and exclusion should be multiplied by 2.5.

**GSM Note:**

1. Per KDB 941225 D01v03r01, for SAR test reduction for GSM / GPRS / EDGE modes is determined by the source-based time-averaged output power including tune-up tolerance. The mode with highest specified time-averaged output power should be tested for SAR compliance in the applicable exposure conditions. For modes with the same specified maximum output power and tolerance, the higher number time-slot configuration should be tested. Therefore, the GPRS 2Tx slots for GSM850/GSM1900 are considered as the primary mode.
2. Other configurations of GSM / GPRS / EDGE are considered as secondary modes. The 3G SAR test reduction procedure is applied, when the maximum output power and tune-up tolerance specified for production units in a secondary mode is  $\leq$  ¼ dB higher than the primary mode, SAR measurement is not required for the secondary mode.

**WCDMA Note:**

1. Per KDB 941225 D01v03r01, for SAR testing is measured using a 12.2 kbps RMC with TPC bits configured to all "1's".
2. Per KDB 941225 D01v03r01, RMC 12.2kbps setting is used to evaluate SAR. The maximum output power and tune-up tolerance specified for production units in HSDPA / HSUPA / DC-HSDPA is  $\leq$  ¼ dB higher than RMC 12.2Kbps or when the highest reported SAR of the RMC12.2Kbps is scaled by the ratio of specified maximum output power and tune-up tolerance of HSDPA / HSUPA / DC-HSDPA to RMC12.2Kbps and the adjusted SAR is  $\leq$  1.2 W/kg, SAR measurement is not required for HSDPA / HSUPA / DC-HSDPA, and according to the following RF output power, the output power results of the secondary modes (HSDPA / HSUPA / DC-HSDPA) are less than ¼ dB higher than the primary modes; therefore, SAR measurement is not required for HSDPA / HSUPA / DC-HSDPA.

**LTE Note:**

1. Per KDB 941225 D05v02r05, start with the largest channel bandwidth and measure SAR for QPSK with 1 RB allocation, using the RB offset and required test channel combination with the highest maximum output power for RB offsets at the upper edge, middle and lower edge of each required test channel.
2. Per KDB 941225 D05v02r05, 50% RB allocation for QPSK SAR testing follows 1RB QPSK allocation procedure.
3. Per KDB 941225 D05v02r05, for QPSK with 100% RB allocation, SAR is not required when the highest maximum output power for 100 % RB allocation is less than the highest maximum output power in 50% and 1 RB allocations and the highest reported SAR for 1 RB and 50% RB allocation are  $\leq$  0.8 W/kg. Otherwise, SAR is measured for the highest output power channel; and if the reported SAR is  $>$  1.45 W/kg, the remaining required test channels must also be tested.
4. Per KDB 941225 D05v02r05, 16QAM/64QAM output power for each RB allocation configuration is  $>$  not ½ dB higher than the same configuration in QPSK and the reported SAR for the QPSK configuration is  $\leq$  1.45 W/kg; Per KDB 941225 D05v02r05, 16QAM/64QAM SAR testing is not required.
5. Per KDB 941225 D05v02r05, smaller bandwidth output power for each RB allocation configuration is  $>$  not ½ dB higher than the same configuration in the largest supported bandwidth, and the reported SAR for the largest supported bandwidth is  $\leq$  1.45 W/kg; Per KDB 941225 D05v02r05, smaller bandwidth SAR testing is not required.
6. For LTE B4 / B5 the maximum bandwidth does not support three non-overlapping channels, per KDB 941225 D05v02r05, when a device supports overlapping channel assignment in a channel bandwidth configuration, the middle channel of the group of overlapping channels should be selected for testing.
7. LTE B4 SAR test was covered by B66; according to April 2015 TCB workshop, SAR test for overlapping LTE bands can be reduced if
  - c. the maximum output power, including tolerance, for the smaller band is  $\leq$  the larger band to qualify for the SAR test exclusion
  - d. the channel bandwidth and other operating parameters for the smaller band are fully supported by the larger band





**WLAN Note:**

1. Per KDB 248227 D01v02r02, for 2.4GHz 802.11g/n SAR testing is not required when the highest reported SAR for DSSS is adjusted by the ratio of OFDM to DSSS specified maximum output power and the adjusted SAR is  $\leq 1.2$  W/kg.
2. When the reported SAR of the test position is  $> 0.4$  W/kg, SAR is repeated for the 802.11 transmission mode configuration tested in the initial test position to measure the subsequent next closet/smallest test separation distance and maximum coupling test position on the highest maximum output power channel, until the report SAR is  $\leq 0.8$  W/kg or all required test position are tested.
3. For all positions / configurations, when the reported SAR is  $> 0.8$  W/kg, SAR is measured for these test positions / configurations on the subsequent next highest measured output power channel(s) until the reported SAR is  $\leq 1.2$  W/kg or all required channels are tested.
4. During SAR testing the WLAN transmission was verified using a spectrum analyzer.



**15.1 Head SAR**

**<GSM SAR>**

Plot No.	Band	Mode	Test Position	Power Mode	Ch.	Freq. (MHz)	Average Power (dBm)	Tune-Up Limit (dBm)	Tune-up Scaling Factor	Power Drift (dB)	Measured 1g SAR (W/kg)	Reported 1g SAR (W/kg)
01	GSM850	GPRS 2 Tx slots	Right Cheek	Full	251	848.8	30.52	31.50	1.253	-0.07	0.442	<b>0.554</b>
	GSM850	GPRS 2 Tx slots	Right Tilted	Full	251	848.8	30.52	31.50	1.253	-0.02	0.232	0.291
	GSM850	GPRS 2 Tx slots	Left Cheek	Full	251	848.8	30.52	31.50	1.253	0.09	0.428	0.536
	GSM850	GPRS 2 Tx slots	Left Tilted	Full	251	848.8	30.52	31.50	1.253	-0.01	0.233	0.292
02	GSM1900	GPRS 2 Tx slots	Right Cheek	Full	661	1880	27.72	28.50	1.197	0.09	0.129	<b>0.154</b>
	GSM1900	GPRS 2 Tx slots	Right Tilted	Full	661	1880	27.72	28.50	1.197	-0.12	0.095	0.114
	GSM1900	GPRS 2 Tx slots	Left Cheek	Full	661	1880	27.72	28.50	1.197	-0.04	0.103	0.123
	GSM1900	GPRS 2 Tx slots	Left Tilted	Full	661	1880	27.72	28.50	1.197	0.04	0.079	0.094

**<WCDMA SAR>**

Plot No.	Band	Mode	Test Position	Power Mode	Ch.	Freq. (MHz)	Average Power (dBm)	Tune-Up Limit (dBm)	Tune-up Scaling Factor	Power Drift (dB)	Measured 1g SAR (W/kg)	Reported 1g SAR (W/kg)
03	WCDMA II	RMC 12.2Kbps	Right Cheek	Full	9400	1880	22.78	24.00	1.324	0.02	0.219	<b>0.290</b>
	WCDMA II	RMC 12.2Kbps	Right Tilted	Full	9400	1880	22.78	24.00	1.324	0.05	0.176	0.233
	WCDMA II	RMC 12.2Kbps	Left Cheek	Full	9400	1880	22.78	24.00	1.324	0.01	0.175	0.232
	WCDMA II	RMC 12.2Kbps	Left Tilted	Full	9400	1880	22.78	24.00	1.324	0.19	0.130	0.172
04	WCDMA IV	RMC 12.2Kbps	Right Cheek	Full	1413	1732.6	22.71	24.00	1.346	0.09	0.127	<b>0.171</b>
	WCDMA IV	RMC 12.2Kbps	Right Tilted	Full	1413	1732.6	22.71	24.00	1.346	0.06	0.086	0.116
	WCDMA IV	RMC 12.2Kbps	Left Cheek	Full	1413	1732.6	22.71	24.00	1.346	0.01	0.080	0.108
	WCDMA IV	RMC 12.2Kbps	Left Tilted	Full	1413	1732.6	22.71	24.00	1.346	-0.01	0.065	0.088
05	WCDMA V	RMC 12.2Kbps	Right Cheek	Full	4182	836.4	22.72	24.00	1.343	-0.17	0.403	<b>0.541</b>
	WCDMA V	RMC 12.2Kbps	Right Tilted	Full	4182	836.4	22.72	24.00	1.343	0.01	0.199	0.267
	WCDMA V	RMC 12.2Kbps	Left Cheek	Full	4182	836.4	22.72	24.00	1.343	-0.08	0.371	0.498
	WCDMA V	RMC 12.2Kbps	Left Tilted	Full	4182	836.4	22.72	24.00	1.343	0.02	0.183	0.246



<FDD LTE SAR>

Plot No.	Band	BW (MHz)	Modulation	RB Size	RB Offset	Test Position	Power Mode	Ch.	Freq. (MHz)	Average Power (dBm)	Tune-Up Limit (dBm)	Tune-up Scaling Factor	Power Drift (dB)	Measured 1g SAR (W/kg)	Reported 1g SAR (W/kg)
06	LTE Band 2	20M	QPSK	1	0	Right Cheek	Full	18900	1880	22.89	24.00	1.291	0.01	0.221	<b>0.285</b>
	LTE Band 2	20M	QPSK	50	0	Right Cheek	Full	18900	1880	21.67	23.00	1.358	0.02	0.114	0.155
	LTE Band 2	20M	QPSK	1	0	Right Tilted	Full	18900	1880	22.89	24.00	1.291	0.01	0.181	0.234
	LTE Band 2	20M	QPSK	50	0	Right Tilted	Full	18900	1880	21.67	23.00	1.358	0.11	0.091	0.124
	LTE Band 2	20M	QPSK	1	0	Left Cheek	Full	18900	1880	22.89	24.00	1.291	0.06	0.213	0.275
	LTE Band 2	20M	QPSK	50	0	Left Cheek	Full	18900	1880	21.67	23.00	1.358	0.04	0.103	0.140
	LTE Band 2	20M	QPSK	1	0	Left Tilted	Full	18900	1880	22.89	24.00	1.291	0.06	0.140	0.181
	LTE Band 2	20M	QPSK	50	0	Left Tilted	Full	18900	1880	21.67	23.00	1.358	0.07	0.071	0.096
07	LTE Band 5	10M	QPSK	1	0	Right Cheek	Full	20525	836.5	22.76	24.00	1.330	-0.09	0.607	<b>0.808</b>
	LTE Band 5	10M	QPSK	25	0	Right Cheek	Full	20525	836.5	21.67	23.00	1.358	0.01	0.327	0.444
	LTE Band 5	10M	QPSK	50	0	Right Cheek	Full	20525	836.5	21.64	23.00	1.368	0.04	0.208	0.284
	LTE Band 5	10M	QPSK	1	0	Right Tilted	Full	20525	836.5	22.76	24.00	1.330	0.03	0.270	0.359
	LTE Band 5	10M	QPSK	25	0	Right Tilted	Full	20525	836.5	21.67	23.00	1.358	0.01	0.152	0.206
	LTE Band 5	10M	QPSK	1	0	Left Cheek	Full	20525	836.5	22.76	24.00	1.330	-0.11	0.607	0.808
	LTE Band 5	10M	QPSK	25	0	Left Cheek	Full	20525	836.5	21.67	23.00	1.358	-0.1	0.321	0.436
	LTE Band 5	10M	QPSK	50	0	Left Cheek	Full	20525	836.5	21.64	23.00	1.368	0.07	0.207	0.283
	LTE Band 5	10M	QPSK	1	0	Left Tilted	Full	20525	836.5	22.76	24.00	1.330	0.05	0.312	0.415
	LTE Band 5	10M	QPSK	25	0	Left Tilted	Full	20525	836.5	21.67	23.00	1.358	-0.06	0.180	0.244
	LTE Band 7	20M	QPSK	1	99	Right Cheek	Full	20850	2510	22.76	24.00	1.330	0.06	0.112	0.149
	LTE Band 7	20M	QPSK	50	50	Right Cheek	Full	20850	2510	21.80	23.00	1.318	0.06	0.037	0.048
LTE Band 7	20M	QPSK	1	99	Right Tilted	Full	20850	2510	22.76	24.00	1.330	0.01	0.041	0.054	
LTE Band 7	20M	QPSK	50	50	Right Tilted	Full	20850	2510	21.80	23.00	1.318	0.08	0.025	0.032	
08	LTE Band 7	20M	QPSK	1	99	Left Cheek	Full	20850	2510	22.76	24.00	1.330	0.06	0.173	<b>0.230</b>
	LTE Band 7	20M	QPSK	50	50	Left Cheek	Full	20850	2510	21.80	23.00	1.318	-0.08	0.054	0.072
	LTE Band 7	20M	QPSK	1	99	Left Tilted	Full	20850	2510	22.76	24.00	1.330	-0.09	0.071	0.095
	LTE Band 7	20M	QPSK	50	50	Left Tilted	Full	20850	2510	21.80	23.00	1.318	0.03	0.040	0.053
09	LTE Band 66	20M	QPSK	1	0	Right Cheek	Full	132072	1720	22.56	24.00	1.393	-0.05	0.086	<b>0.120</b>
	LTE Band 66	20M	QPSK	50	0	Right Cheek	Full	132072	1720	21.59	23.00	1.384	0.06	0.059	0.081
	LTE Band 66	20M	QPSK	1	0	Right Tilted	Full	132072	1720	22.56	24.00	1.393	0.03	0.045	0.062
	LTE Band 66	20M	QPSK	50	0	Right Tilted	Full	132072	1720	21.59	23.00	1.384	0.07	0.038	0.053
	LTE Band 66	20M	QPSK	1	0	Left Cheek	Full	132072	1720	22.56	24.00	1.393	0.04	0.031	0.043
	LTE Band 66	20M	QPSK	50	0	Left Cheek	Full	132072	1720	21.59	23.00	1.384	0.08	0.022	0.031
	LTE Band 66	20M	QPSK	1	0	Left Tilted	Full	132072	1720	22.56	24.00	1.393	0.01	0.038	0.052
	LTE Band 66	20M	QPSK	50	0	Left Tilted	Full	132072	1720	21.59	23.00	1.384	-0.02	0.027	0.037



<WLAN 2.4GHz SAR>

Plot No.	Band	Mode	Test Position	Ch.	Freq. (MHz)	Average Power (dBm)	Tune-Up Limit (dBm)	Tune-up Scaling Factor	Duty Cycle %	Duty Cycle Scaling Factor	Power Drift (dB)	Measured 1g SAR (W/kg)	Reported 1g SAR (W/kg)
	WLAN2.4GHz	802.11b 1Mbps	Right Cheek	1	2412	18.93	19.50	1.140	98.63	1.014	0.01	0.274	0.317
	WLAN2.4GHz	802.11b 1Mbps	Right Tilted	1	2412	18.93	19.50	1.140	98.63	1.014	0.06	0.214	0.247
10	WLAN2.4GHz	802.11b 1Mbps	Left Cheek	1	2412	18.93	19.50	1.140	98.63	1.014	-0.07	0.888	1.027
	WLAN2.4GHz	802.11b 1Mbps	Left Tilted	1	2412	18.93	19.50	1.140	98.63	1.014	0.01	0.666	0.770
	WLAN2.4GHz	802.11b 1Mbps	Left Cheek	11	2462	18.69	19.50	1.205	98.63	1.014	-0.04	0.779	0.952

<Bluetooth SAR>

Plot No.	Band	Mode	Test Position	Ch.	Freq. (MHz)	Average Power (dBm)	Tune-Up Limit (dBm)	Tune-up Scaling Factor	Duty Cycle %	Duty Cycle Scaling Factor	Power Drift (dB)	Measured 1g SAR (W/kg)	Reported 1g SAR (W/kg)
	Bluetooth	1Mbps	Right Cheek	78	2480	7.06	8.00	1.242	77.36	1.077	0.02	0.014	0.019
	Bluetooth	1Mbps	Right Tilted	78	2480	7.06	8.00	1.242	77.36	1.077	0.05	0.011	0.015
11	Bluetooth	1Mbps	Left Cheek	78	2480	7.06	8.00	1.242	77.36	1.077	-0.02	0.033	0.045
	Bluetooth	1Mbps	Left Tilted	78	2480	7.06	8.00	1.242	77.36	1.077	0.02	0.032	0.043



**15.2 Hotspot SAR**

**<GSM SAR>**

Plot No.	Band	Mode	Test Position	Gap (mm)	Power Mode	Ch.	Freq. (MHz)	Average Power (dBm)	Tune-Up Limit (dBm)	Tune-up Scaling Factor	Power Drift (dB)	Measured 1g SAR (W/kg)	Reported 1g SAR (W/kg)
	GSM850	GPRS 2 Tx slots	Front	5	Reduced	251	848.8	29.37	30.00	1.156	0.02	0.719	0.831
	GSM850	GPRS 2 Tx slots	Front	5	Reduced	128	824.2	29.05	30.00	1.245	-0.02	0.655	0.815
	GSM850	GPRS 2 Tx slots	Front	5	Reduced	189	836.4	29.07	30.00	1.239	-0.01	0.410	0.508
12	GSM850	GPRS 2 Tx slots	Back	5	Reduced	251	848.8	29.37	30.00	1.156	-0.04	1.200	<b>1.387</b>
	GSM850	GPRS 2 Tx slots	Back	5	Reduced	128	824.2	29.05	30.00	1.245	0.02	0.753	0.937
	GSM850	GPRS 2 Tx slots	Back	5	Reduced	189	836.4	29.07	30.00	1.239	0.08	1.090	1.350
	GSM850	GPRS 2 Tx slots	Left Side	5	Reduced	251	848.8	29.37	30.00	1.156	0.02	0.594	0.687
	GSM850	GPRS 2 Tx slots	Right Side	5	Reduced	251	848.8	29.37	30.00	1.156	-0.03	0.606	0.701
	GSM850	GPRS 2 Tx slots	Bottom Side	5	Reduced	251	848.8	29.37	30.00	1.156	-0.02	0.282	0.326
	GSM1900	GPRS 2 Tx slots	Front	5	Reduced	661	1880	23.12	24.00	1.225	-0.03	0.326	0.399
13	GSM1900	GPRS 2 Tx slots	Back	5	Reduced	661	1880	23.12	24.00	1.225	-0.15	1.150	<b>1.408</b>
	GSM1900	GPRS 2 Tx slots	Back	5	Reduced	512	1850.2	23.09	24.00	1.233	-0.04	0.893	1.101
	GSM1900	GPRS 2 Tx slots	Back	5	Reduced	810	1909.8	22.84	24.00	1.306	-0.16	1.050	1.371
	GSM1900	GPRS 2 Tx slots	Left Side	5	Reduced	661	1880	23.12	24.00	1.225	0.02	0.066	0.080
	GSM1900	GPRS 2 Tx slots	Right Side	5	Reduced	661	1880	23.12	24.00	1.225	0.03	0.074	0.091
	GSM1900	GPRS 2 Tx slots	Bottom Side	5	Reduced	661	1880	23.12	24.00	1.225	0.19	0.712	0.872
	GSM1900	GPRS 2 Tx slots	Bottom Side	5	Reduced	512	1850.2	23.09	24.00	1.233	-0.02	0.587	0.724
	GSM1900	GPRS 2 Tx slots	Bottom Side	5	Reduced	810	1909.8	22.84	24.00	1.306	0.01	0.665	0.869



<WCDMA SAR>

Plot No.	Band	Mode	Test Position	Gap (mm)	Power Mode	Ch.	Freq. (MHz)	Average Power (dBm)	Tune-Up Limit (dBm)	Tune-up Scaling Factor	Power Drift (dB)	Measured 1g SAR (W/kg)	Reported 1g SAR (W/kg)
	WCDMA II	RMC 12.2Kbps	Front	5	Reduced	9400	1880	14.89	16.50	1.449	-0.05	0.237	0.343
14	WCDMA II	RMC 12.2Kbps	Back	5	Reduced	9400	1880	14.89	16.50	1.449	-0.17	0.928	1.344
	WCDMA II	RMC 12.2Kbps	Back	5	Reduced	9262	1852.4	14.68	16.50	1.521	0.04	0.785	1.194
	WCDMA II	RMC 12.2Kbps	Back	5	Reduced	9538	1907.6	14.86	16.50	1.459	-0.08	0.882	1.287
	WCDMA II	RMC 12.2Kbps	Left Side	5	Reduced	9400	1880	14.89	16.50	1.449	0.03	0.052	0.075
	WCDMA II	RMC 12.2Kbps	Right Side	5	Reduced	9400	1880	14.89	16.50	1.449	0.05	0.059	0.085
	WCDMA II	RMC 12.2Kbps	Bottom Side	5	Reduced	9400	1880	14.89	16.50	1.449	0.03	0.620	0.898
	WCDMA II	RMC 12.2Kbps	Bottom Side	5	Reduced	9262	1852.4	14.68	16.50	1.521	-0.08	0.474	0.721
	WCDMA II	RMC 12.2Kbps	Bottom Side	5	Reduced	9538	1907.6	14.86	16.50	1.459	0.05	0.700	1.021
	WCDMA IV	RMC 12.2Kbps	Front	5	Reduced	1413	1732.6	14.12	15.50	1.374	0.09	0.301	0.414
15	WCDMA IV	RMC 12.2Kbps	Back	5	Reduced	1413	1732.6	14.12	15.50	1.374	0.02	1.000	1.374
	WCDMA IV	RMC 12.2Kbps	Back	5	Reduced	1312	1712.4	14.07	15.50	1.390	-0.06	0.966	1.343
	WCDMA IV	RMC 12.2Kbps	Back	5	Reduced	1513	1752.6	14.10	15.50	1.380	0.02	0.906	1.251
	WCDMA IV	RMC 12.2Kbps	Left Side	5	Reduced	1413	1732.6	14.12	15.50	1.374	0.03	0.033	0.045
	WCDMA IV	RMC 12.2Kbps	Right Side	5	Reduced	1413	1732.6	14.12	15.50	1.374	0.03	0.065	0.090
	WCDMA IV	RMC 12.2Kbps	Bottom Side	5	Reduced	1413	1732.6	14.12	15.50	1.374	0.02	0.963	1.323
	WCDMA IV	RMC 12.2Kbps	Bottom Side	5	Reduced	1312	1712.4	14.07	15.50	1.390	0.03	0.900	1.251
	WCDMA IV	RMC 12.2Kbps	Bottom Side	5	Reduced	1513	1752.6	14.10	15.50	1.380	0.03	0.860	1.187
	WCDMA V	RMC 12.2Kbps	Front	5	Reduced	4182	836.4	22.16	23.00	1.213	0.02	0.558	0.677
	WCDMA V	RMC 12.2Kbps	Back	5	Reduced	4182	836.4	22.16	23.00	1.213	-0.09	1.010	1.226
	WCDMA V	RMC 12.2Kbps	Back	5	Reduced	4132	826.4	22.09	23.00	1.233	0.02	0.937	1.155
16	WCDMA V	RMC 12.2Kbps	Back	5	Reduced	4233	846.6	22.08	23.00	1.236	-0.03	1.050	1.298
	WCDMA V	RMC 12.2Kbps	Left Side	5	Reduced	4182	836.4	22.16	23.00	1.213	-0.01	0.540	0.655
	WCDMA V	RMC 12.2Kbps	Right Side	5	Reduced	4182	836.4	22.16	23.00	1.213	-0.03	0.548	0.665
	WCDMA V	RMC 12.2Kbps	Bottom Side	5	Reduced	4182	836.4	22.16	23.00	1.213	-0.06	0.167	0.203



<LTE SAR>

Plot No.	Band	BW (MHz)	Modulation	RB Size	RB Offset	Test Position	Gap (mm)	Power Mode	Ch.	Freq. (MHz)	Average Power (dBm)	Tune-Up Limit (dBm)	Tune-up Scaling Factor	Power Drift (dB)	Measured 1g SAR (W/kg)	Reported 1g SAR (W/kg)
	LTE Band 2	20M	QPSK	1	0	Front	5	Reduced	18900	1880	15.42	16.00	1.143	-0.04	0.334	0.382
	LTE Band 2	20M	QPSK	50	0	Front	5	Reduced	18900	1880	15.19	16.00	1.205	-0.03	0.335	0.404
	LTE Band 2	20M	QPSK	1	0	Back	5	Reduced	18900	1880	15.42	16.00	1.143	-0.07	1.020	1.166
	LTE Band 2	20M	QPSK	1	0	Back	5	Reduced	18700	1860	15.06	16.00	1.242	0.12	0.893	1.109
	LTE Band 2	20M	QPSK	1	0	Back	5	Reduced	19100	1900	15.02	16.00	1.253	0.08	1.000	1.253
	LTE Band 2	20M	QPSK	50	0	Back	5	Reduced	18900	1880	15.19	16.00	1.205	0.13	1.100	1.326
	LTE Band 2	20M	QPSK	50	0	Back	5	Reduced	18700	1860	15.05	16.00	1.245	0.03	0.995	1.238
17	LTE Band 2	20M	QPSK	50	0	Back	5	Reduced	19100	1900	15.00	16.00	1.259	-0.08	1.100	1.385
	LTE Band 2	20M	QPSK	100	0	Back	5	Reduced	18900	1880	15.10	16.00	1.230	-0.05	1.090	1.341
	LTE Band 2	20M	QPSK	1	0	Left Side	5	Reduced	18900	1880	15.42	16.00	1.143	0.04	0.078	0.089
	LTE Band 2	20M	QPSK	50	0	Left Side	5	Reduced	18900	1880	15.19	16.00	1.205	0.06	0.066	0.080
	LTE Band 2	20M	QPSK	1	0	Right Side	5	Reduced	18900	1880	15.42	16.00	1.143	0.03	0.066	0.075
	LTE Band 2	20M	QPSK	50	0	Right Side	5	Reduced	18900	1880	15.19	16.00	1.205	0.09	0.064	0.077
	LTE Band 2	20M	QPSK	1	0	Bottom Side	5	Reduced	18900	1880	15.42	16.00	1.143	0.18	0.675	0.771
	LTE Band 2	20M	QPSK	50	0	Bottom Side	5	Reduced	18900	1880	15.19	16.00	1.205	0.16	0.672	0.810
	LTE Band 2	20M	QPSK	50	0	Bottom Side	5	Reduced	18700	1860	15.05	16.00	1.245	0.02	0.503	0.626
	LTE Band 2	20M	QPSK	50	0	Bottom Side	5	Reduced	19100	1900	15.00	16.00	1.259	0.13	0.723	0.910
	LTE Band 2	20M	QPSK	100	0	Bottom Side	5	Reduced	18900	1880	15.10	16.00	1.230	0.06	0.672	0.827
	LTE Band 5	10M	QPSK	1	0	Front	5	Full	20525	836.5	22.76	24.00	1.330	-0.08	0.506	0.673
	LTE Band 5	10M	QPSK	25	0	Front	5	Full	20525	836.5	21.67	23.00	1.358	-0.08	0.288	0.391
18	LTE Band 5	10M	QPSK	1	0	Back	5	Full	20525	836.5	22.76	24.00	1.330	-0.06	1.040	1.384
	LTE Band 5	10M	QPSK	25	0	Back	5	Full	20525	836.5	21.67	23.00	1.358	-0.09	0.562	0.763
	LTE Band 5	10M	QPSK	50	0	Back	5	Full	20525	836.5	21.64	23.00	1.368	-0.01	0.560	0.766
	LTE Band 5	10M	QPSK	1	0	Left Side	5	Full	20525	836.5	22.76	24.00	1.330	0.17	0.566	0.753
	LTE Band 5	10M	QPSK	25	0	Left Side	5	Full	20525	836.5	21.67	23.00	1.358	-0.03	0.321	0.436
	LTE Band 5	10M	QPSK	1	0	Right Side	5	Full	20525	836.5	22.76	24.00	1.330	0.04	0.590	0.785
	LTE Band 5	10M	QPSK	25	0	Right Side	5	Full	20525	836.5	21.67	23.00	1.358	-0.05	0.333	0.452
	LTE Band 5	10M	QPSK	1	0	Bottom Side	5	Full	20525	836.5	22.76	24.00	1.330	-0.09	0.171	0.228
	LTE Band 5	10M	QPSK	25	0	Bottom Side	5	Full	20525	836.5	21.67	23.00	1.358	-0.03	0.107	0.145
	LTE Band 7	20M	QPSK	1	99	Front	5	Reduced	20850	2510	18.00	19.00	1.259	-0.04	0.300	0.378
	LTE Band 7	20M	QPSK	50	50	Front	5	Reduced	20850	2510	17.97	19.00	1.268	-0.07	0.300	0.380
	LTE Band 7	20M	QPSK	1	99	Back	5	Reduced	20850	2510	18.00	19.00	1.259	-0.08	0.905	1.139
	LTE Band 7	20M	QPSK	1	99	Back	5	Reduced	21100	2535	17.74	19.00	1.337	-0.01	0.958	1.280
	LTE Band 7	20M	QPSK	1	99	Back	5	Reduced	21350	2560	17.66	19.00	1.361	-0.06	0.971	1.322
	LTE Band 7	20M	QPSK	50	50	Back	5	Reduced	20850	2510	17.97	19.00	1.268	-0.03	0.915	1.160
	LTE Band 7	20M	QPSK	50	50	Back	5	Reduced	21100	2535	17.89	19.00	1.291	0.06	0.976	1.260
19	LTE Band 7	20M	QPSK	50	50	Back	5	Reduced	21350	2560	17.75	19.00	1.334	0.01	1.000	1.334
	LTE Band 7	20M	QPSK	100	0	Back	5	Reduced	20850	2510	17.88	19.00	1.294	-0.07	0.912	1.180
	LTE Band 7	20M	QPSK	1	99	Left Side	5	Reduced	20850	2510	18.00	19.00	1.259	0.03	0.105	0.132
	LTE Band 7	20M	QPSK	50	50	Left Side	5	Reduced	20850	2510	17.97	19.00	1.268	-0.06	0.104	0.132
	LTE Band 7	20M	QPSK	1	99	Right Side	5	Reduced	20850	2510	18.00	19.00	1.259	0.02	0.137	0.172
	LTE Band 7	20M	QPSK	50	50	Right Side	5	Reduced	20850	2510	17.97	19.00	1.268	0.03	0.138	0.175
	LTE Band 7	20M	QPSK	1	99	Bottom Side	5	Reduced	20850	2510	18.00	19.00	1.259	-0.09	0.598	0.753
	LTE Band 7	20M	QPSK	50	50	Bottom Side	5	Reduced	20850	2510	17.97	19.00	1.268	0.03	0.616	0.781



**FCC SAR Test Report**

**Report No. : FA902103**

Plot No.	Band	BW (MHz)	Modulation	RB Size	RB Offset	Test Position	Gap (mm)	Power Mode	Ch.	Freq. (MHz)	Average Power (dBm)	Tune-Up Limit (dBm)	Tune-up Scaling Factor	Power Drift (dB)	Measured 1g SAR (W/kg)	Reported 1g SAR (W/kg)
	LTE Band 66	20M	QPSK	1	0	Front	5	Reduced	132072	1720	15.20	16.00	1.202	-0.08	0.316	0.380
	LTE Band 66	20M	QPSK	50	0	Front	5	Reduced	132072	1720	15.05	16.00	1.245	-0.08	0.325	0.404
	LTE Band 66	20M	QPSK	1	0	Back	5	Reduced	132072	1720	15.20	16.00	1.202	-0.04	0.984	1.183
20	LTE Band 66	20M	QPSK	1	0	Back	5	Reduced	132322	1745	14.93	16.00	1.279	-0.04	1.020	<b>1.305</b>
	LTE Band 66	20M	QPSK	1	0	Back	5	Reduced	132572	1770	14.86	16.00	1.300	-0.02	0.927	1.205
	LTE Band 66	20M	QPSK	50	0	Back	5	Reduced	132072	1720	15.05	16.00	1.245	-0.11	0.986	1.227
	LTE Band 66	20M	QPSK	50	0	Back	5	Reduced	132322	1745	14.89	16.00	1.291	0.03	1.000	1.291
	LTE Band 66	20M	QPSK	50	0	Back	5	Reduced	132572	1770	14.85	16.00	1.303	0.09	0.892	1.162
	LTE Band 66	20M	QPSK	100	0	Back	5	Reduced	132072	1720	14.95	16.00	1.274	0.05	0.992	1.263
	LTE Band 66	20M	QPSK	1	0	Left Side	5	Reduced	132072	1720	15.20	16.00	1.202	0.01	0.034	0.041
	LTE Band 66	20M	QPSK	50	0	Left Side	5	Reduced	132072	1720	15.05	16.00	1.245	0.02	0.034	0.043
	LTE Band 66	20M	QPSK	1	0	Right Side	5	Reduced	132072	1720	15.20	16.00	1.202	0.13	0.064	0.077
	LTE Band 66	20M	QPSK	50	0	Right Side	5	Reduced	132072	1720	15.05	16.00	1.245	0.01	0.064	0.080
	LTE Band 66	20M	QPSK	1	0	Bottom Side	5	Reduced	132072	1720	15.20	16.00	1.202	0.08	0.863	1.038
	LTE Band 66	20M	QPSK	1	0	Bottom Side	5	Reduced	132322	1745	14.93	16.00	1.279	0.06	0.923	1.181
	LTE Band 66	20M	QPSK	1	0	Bottom Side	5	Reduced	132572	1770	14.86	16.00	1.300	-0.04	0.815	1.060
	LTE Band 66	20M	QPSK	50	0	Bottom Side	5	Reduced	132072	1720	15.05	16.00	1.245	0.09	0.892	1.110
	LTE Band 66	20M	QPSK	50	0	Bottom Side	5	Reduced	132322	1745	14.89	16.00	1.291	0.01	0.900	1.162
	LTE Band 66	20M	QPSK	50	0	Bottom Side	5	Reduced	132572	1770	14.85	16.00	1.303	-0.03	0.805	1.049
	LTE Band 66	20M	QPSK	100	0	Bottom Side	5	Reduced	132072	1720	14.95	16.00	1.274	0.09	0.896	1.141

**<WLAN 2.4GHz SAR>**

Plot No.	Band	Mode	Test Position	Gap (mm)	Power Mode	Ch.	Freq. (MHz)	Average Power (dBm)	Tune-Up Limit (dBm)	Tune-up Scaling Factor	Duty Cycle %	Duty Cycle Scaling Factor	Power Drift (dB)	Measured 1g SAR (W/kg)	Reported 1g SAR (W/kg)
	WLAN2.4GHz	802.11b 1Mbps	Front	5	Full	1	2412	18.93	19.50	1.140	98.63	1.014	0.01	0.450	0.520
	WLAN2.4GHz	802.11b 1Mbps	Back	5	Full	1	2412	18.93	19.50	1.140	98.63	1.014	-0.09	0.785	0.908
	WLAN2.4GHz	802.11b 1Mbps	Right Side	5	Full	1	2412	18.93	19.50	1.140	98.63	1.014	0.08	0.616	0.712
	WLAN2.4GHz	802.11b 1Mbps	Top Side	5	Full	1	2412	18.93	19.50	1.140	98.63	1.014	0.01	0.339	0.392
21	WLAN2.4GHz	802.11b 1Mbps	Back	5	Full	11	2462	18.69	19.50	1.205	98.63	1.014	-0.19	0.839	<b>1.025</b>

**<Bluetooth SAR>**

Plot No.	Band	Mode	Test Position	Gap (mm)	Ch.	Freq. (MHz)	Average Power (dBm)	Tune-Up Limit (dBm)	Tune-up Scaling Factor	Duty Cycle %	Duty Cycle Scaling Factor	Power Drift (dB)	Measured 1g SAR (W/kg)	Reported 1g SAR (W/kg)
	Bluetooth	1Mbps	Front	5	78	2480	7.06	8.00	1.242	77.36	1.077	0.03	0.017	0.023
22	Bluetooth	1Mbps	Back	5	78	2480	7.06	8.00	1.242	77.36	1.077	-0.09	0.049	<b>0.066</b>
	Bluetooth	1Mbps	Right Side	5	78	2480	7.06	8.00	1.242	77.36	1.077	0.04	0.034	0.046
	Bluetooth	1Mbps	Top Side	5	78	2480	7.06	8.00	1.242	77.36	1.077	0.05	0.020	0.027





**15.3 Body Worn Accessory SAR**

**<GSM SAR>**

Plot No.	Band	Mode	Test Position	Gap (mm)	Headset	Power Mode	Ch.	Freq. (MHz)	Average Power (dBm)	Tune-Up Limit (dBm)	Tune-up Scaling Factor	Power Drift (dB)	Measured 1g SAR (W/kg)	Reported 1g SAR (W/kg)
	GSM850	GPRS 2 Tx slots	Front	5	-	Reduced	251	848.8	29.37	30.00	1.156	0.02	0.719	0.831
	GSM850	GPRS 2 Tx slots	Front	5	-	Reduced	128	824.2	29.05	30.00	1.245	-0.02	0.655	0.815
	GSM850	GPRS 2 Tx slots	Front	5	-	Reduced	189	836.4	29.07	30.00	1.239	-0.01	0.410	0.508
23	GSM850	GPRS 2 Tx slots	Back	5	-	Reduced	251	848.8	29.37	30.00	1.156	-0.04	1.200	<b>1.387</b>
	GSM850	GPRS 2 Tx slots	Back	5	-	Reduced	128	824.2	29.05	30.00	1.245	0.02	0.753	0.937
	GSM850	GPRS 2 Tx slots	Back	5	-	Reduced	189	836.4	29.07	30.00	1.239	0.08	1.090	1.350
	GSM850	GPRS 2 Tx slots	Back	5	Headset	Reduced	251	848.8	29.37	30.00	1.156	-0.07	1.070	1.237
	GSM1900	GPRS 2 Tx slots	Front	5	-	Reduced	661	1880	23.12	24.00	1.225	-0.03	0.326	0.399
24	GSM1900	GPRS 2 Tx slots	Back	5	-	Reduced	661	1880	23.12	24.00	1.225	-0.15	1.150	<b>1.408</b>
	GSM1900	GPRS 2 Tx slots	Back	5	-	Reduced	512	1850.2	23.09	24.00	1.233	-0.04	0.893	1.101
	GSM1900	GPRS 2 Tx slots	Back	5	-	Reduced	810	1909.8	22.84	24.00	1.306	-0.16	1.050	1.371
	GSM1900	GPRS 2 Tx slots	Back	5	Headset	Reduced	661	1880	23.12	24.00	1.225	0.12	1.090	1.335

**<WCDMA SAR>**

Plot No.	Band	Mode	Test Position	Gap (mm)	Headset	Power Mode	Ch.	Freq. (MHz)	Average Power (dBm)	Tune-Up Limit (dBm)	Tune-up Scaling Factor	Power Drift (dB)	Measured 1g SAR (W/kg)	Reported 1g SAR (W/kg)
	WCDMA II	RMC 12.2Kbps	Front	5	-	Reduced	9400	1880	14.89	16.50	1.449	-0.05	0.237	0.343
25	WCDMA II	RMC 12.2Kbps	Back	5	-	Reduced	9400	1880	14.89	16.50	1.449	-0.17	0.928	<b>1.344</b>
	WCDMA II	RMC 12.2Kbps	Back	5	-	Reduced	9262	1852.4	14.68	16.50	1.521	0.04	0.785	1.194
	WCDMA II	RMC 12.2Kbps	Back	5	-	Reduced	9538	1907.6	14.86	16.50	1.459	-0.08	0.882	1.287
	WCDMA II	RMC 12.2Kbps	Back	5	Headset	Reduced	9400	1880	14.89	16.50	1.449	0.02	0.900	1.304
	WCDMA IV	RMC 12.2Kbps	Front	5	-	Reduced	1413	1732.6	14.12	15.50	1.374	0.09	0.301	0.414
	WCDMA IV	RMC 12.2Kbps	Back	5	-	Reduced	1413	1732.6	14.12	15.50	1.374	0.02	1.000	1.374
	WCDMA IV	RMC 12.2Kbps	Back	5	-	Reduced	1312	1712.4	14.07	15.50	1.390	-0.06	0.966	1.343
	WCDMA IV	RMC 12.2Kbps	Back	5	-	Reduced	1513	1752.6	14.10	15.50	1.380	0.02	0.906	1.251
26	WCDMA IV	RMC 12.2Kbps	Back	5	Headset	Reduced	1413	1732.6	14.12	15.50	1.374	0.09	1.050	<b>1.443</b>
	WCDMA IV	RMC 12.2Kbps	Back	5	Headset	Reduced	1312	1712.4	14.07	15.50	1.390	0.02	1.010	1.404
	WCDMA IV	RMC 12.2Kbps	Back	5	Headset	Reduced	1513	1752.6	14.10	15.50	1.380	0.05	0.986	1.361
	WCDMA V	RMC 12.2Kbps	Front	5	-	Reduced	4182	836.4	22.16	23.00	1.213	0.02	0.558	0.677
	WCDMA V	RMC 12.2Kbps	Back	5	-	Reduced	4182	836.4	22.16	23.00	1.213	-0.09	1.010	1.226
	WCDMA V	RMC 12.2Kbps	Back	5	-	Reduced	4132	826.4	22.09	23.00	1.233	0.02	0.937	1.155
27	WCDMA V	RMC 12.2Kbps	Back	5	-	Reduced	4233	846.6	22.08	23.00	1.236	-0.03	1.050	<b>1.298</b>
	WCDMA V	RMC 12.2Kbps	Back	5	Headset	Reduced	4233	846.6	22.08	23.00	1.236	-0.04	0.986	1.219



<LTE SAR>

Plot No.	Band	BW (MHz)	Modulation	RB Size	RB Offset	Test Position	Gap (mm)	Headset	Power Mode	Ch.	Freq. (MHz)	Average Power (dBm)	Tune-Up Limit (dBm)	Tune-up Scaling Factor	Power Drift (dB)	Measured 1g SAR (W/kg)	Reported 1g SAR (W/kg)
	LTE Band 2	20M	QPSK	1	0	Front	5	-	Reduced	18900	1880	15.42	16.00	1.143	-0.04	0.334	0.382
	LTE Band 2	20M	QPSK	50	0	Front	5	-	Reduced	18900	1880	15.19	16.00	1.205	-0.03	0.335	0.404
	LTE Band 2	20M	QPSK	1	0	Back	5	-	Reduced	18900	1880	15.42	16.00	1.143	-0.07	1.020	1.166
	LTE Band 2	20M	QPSK	1	0	Back	5	-	Reduced	18700	1860	15.06	16.00	1.242	0.12	0.893	1.109
	LTE Band 2	20M	QPSK	1	0	Back	5	-	Reduced	19100	1900	15.02	16.00	1.253	0.08	1.000	1.253
	LTE Band 2	20M	QPSK	50	0	Back	5	-	Reduced	18900	1880	15.19	16.00	1.205	0.13	1.100	1.326
	LTE Band 2	20M	QPSK	50	0	Back	5	-	Reduced	18700	1860	15.05	16.00	1.245	0.03	0.995	1.238
28	LTE Band 2	20M	QPSK	50	0	Back	5	-	Reduced	19100	1900	15.00	16.00	1.259	-0.08	1.100	1.385
	LTE Band 2	20M	QPSK	100	0	Back	5	-	Reduced	18900	1880	15.10	16.00	1.230	-0.05	1.090	1.341
	LTE Band 2	20M	QPSK	50	0	Back	5	Headset	Reduced	19100	1900	15.00	16.00	1.259	0.03	1.040	1.309
	LTE Band 5	10M	QPSK	1	0	Front	5	-	Full	20525	836.5	22.76	24.00	1.330	-0.08	0.506	0.673
	LTE Band 5	10M	QPSK	25	0	Front	5	-	Full	20525	836.5	21.67	23.00	1.358	-0.08	0.288	0.391
29	LTE Band 5	10M	QPSK	1	0	Back	5	-	Full	20525	836.5	22.76	24.00	1.330	-0.06	1.040	1.384
	LTE Band 5	10M	QPSK	25	0	Back	5	-	Full	20525	836.5	21.67	23.00	1.358	-0.09	0.562	0.763
	LTE Band 5	10M	QPSK	50	0	Back	5	-	Full	20525	836.5	21.64	23.00	1.368	-0.01	0.560	0.766
	LTE Band 5	10M	QPSK	1	0	Back	5	Headset	Full	20525	836.5	22.76	24.00	1.330	-0.07	1.020	1.357
	LTE Band 7	20M	QPSK	1	99	Front	5	-	Reduced	20850	2510	18.00	19.00	1.259	-0.04	0.300	0.378
	LTE Band 7	20M	QPSK	50	50	Front	5	-	Reduced	20850	2510	17.97	19.00	1.268	-0.07	0.300	0.380
	LTE Band 7	20M	QPSK	1	99	Back	5	-	Reduced	20850	2510	18.00	19.00	1.259	-0.08	0.905	1.139
	LTE Band 7	20M	QPSK	1	99	Back	5	-	Reduced	21100	2535	17.74	19.00	1.337	-0.01	0.958	1.280
	LTE Band 7	20M	QPSK	1	99	Back	5	-	Reduced	21350	2560	17.66	19.00	1.361	-0.06	0.971	1.322
	LTE Band 7	20M	QPSK	50	50	Back	5	-	Reduced	20850	2510	17.97	19.00	1.268	-0.03	0.915	1.160
	LTE Band 7	20M	QPSK	50	50	Back	5	-	Reduced	21100	2535	17.89	19.00	1.291	0.06	0.976	1.260
30	LTE Band 7	20M	QPSK	50	50	Back	5	-	Reduced	21350	2560	17.75	19.00	1.334	0.01	1.000	1.334
	LTE Band 7	20M	QPSK	100	0	Back	5	-	Reduced	20850	2510	17.88	19.00	1.294	-0.07	0.912	1.180
	LTE Band 7	20M	QPSK	50	50	Back	5	Headset	Reduced	21350	2560	17.75	19.00	1.334	-0.01	0.990	1.320
	LTE Band 66	20M	QPSK	1	0	Front	5	-	Reduced	132072	1720	15.20	16.00	1.202	-0.08	0.316	0.380
	LTE Band 66	20M	QPSK	50	0	Front	5	-	Reduced	132072	1720	15.05	16.00	1.245	-0.08	0.325	0.404
	LTE Band 66	20M	QPSK	1	0	Back	5	-	Reduced	132072	1720	15.20	16.00	1.202	-0.04	0.984	1.183
31	LTE Band 66	20M	QPSK	1	0	Back	5	-	Reduced	132322	1745	14.93	16.00	1.279	-0.04	1.020	1.305
	LTE Band 66	20M	QPSK	1	0	Back	5	-	Reduced	132572	1770	14.86	16.00	1.300	-0.02	0.927	1.205
	LTE Band 66	20M	QPSK	50	0	Back	5	-	Reduced	132072	1720	15.05	16.00	1.245	-0.11	0.986	1.227
	LTE Band 66	20M	QPSK	50	0	Back	5	-	Reduced	132322	1745	14.89	16.00	1.291	0.03	1.000	1.291
	LTE Band 66	20M	QPSK	50	0	Back	5	-	Reduced	132572	1770	14.85	16.00	1.303	0.09	0.892	1.162
	LTE Band 66	20M	QPSK	100	0	Back	5	-	Reduced	132072	1720	14.95	16.00	1.274	0.05	0.992	1.263
	LTE Band 66	20M	QPSK	1	0	Back	5	Headset	Reduced	132322	1745	14.93	16.00	1.279	0.04	0.828	1.059



<WLAN 2.4GHz SAR>

Plot No.	Band	Mode	Test Position	Gap (mm)	Headset	Power Mode	Ch.	Freq. (MHz)	Average Power (dBm)	Tune-Up Limit (dBm)	Tune-up Scaling Factor	Duty Cycle %	Duty Cycle Scaling Factor	Power Drift (dB)	Measured 1g SAR (W/kg)	Reported 1g SAR (W/kg)
	WLAN2.4GHz	802.11b 1Mbps	Front	5	-	Full	1	2412	18.93	19.50	1.140	98.63	1.014	0.01	0.450	0.520
	WLAN2.4GHz	802.11b 1Mbps	Back	5	-	Full	1	2412	18.93	19.50	1.140	98.63	1.014	-0.09	0.785	0.908
32	WLAN2.4GHz	802.11b 1Mbps	Back	5	-	Full	11	2462	18.69	19.50	1.205	98.63	1.014	-0.19	0.839	1.025

<Bluetooth SAR>

Plot No.	Band	Mode	Test Position	Gap (mm)	Headset	Ch.	Freq. (MHz)	Average Power (dBm)	Tune-Up Limit (dBm)	Tune-up Scaling Factor	Duty Cycle %	Duty Cycle Scaling Factor	Power Drift (dB)	Measured 1g SAR (W/kg)	Reported 1g SAR (W/kg)
	Bluetooth	1Mbps	Front	5	-	78	2480	7.06	8.00	1.242	77.36	1.077	0.03	0.017	0.023
33	Bluetooth	1Mbps	Back	5	-	78	2480	7.06	8.00	1.242	77.36	1.077	-0.09	0.049	0.066



**15.4 Product specific 10g SAR**

**<GSM SAR>**

Plot No.	Band	Mode	Test Position	Gap (mm)	Power Mode	Ch.	Freq. (MHz)	Average Power (dBm)	Tune-Up Limit (dBm)	Tune-up Scaling Factor	Power Drift (dB)	Measured 10g SAR (W/kg)	Reported 10g SAR (W/kg)
34	GSM850	GPRS 2 Tx slots	Back	0	Full	251	848.8	30.52	31.50	1.253	0.03	1.370	<b>1.717</b>
	GSM1900	GPRS 2 Tx slots	Back	0	Full	661	1880	27.72	28.50	1.197	0.04	2.040	2.441
35	GSM1900	GPRS 2 Tx slots	Back	0	Full	512	1850.2	27.58	28.50	1.236	0.04	2.640	<b>3.263</b>
	GSM1900	GPRS 2 Tx slots	Back	0	Full	810	1909.8	27.59	28.50	1.233	0.08	1.890	2.331
	GSM1900	GPRS 2 Tx slots	Bottom Side	0	Full	661	1880	27.72	28.50	1.197	0.05	1.990	2.382
	GSM1900	GPRS 2 Tx slots	Bottom Side	0	Full	512	1850.2	27.58	28.50	1.236	0.09	1.550	1.916
	GSM1900	GPRS 2 Tx slots	Bottom Side	0	Full	810	1909.8	27.59	28.50	1.233	0.09	2.030	2.503

**<WCDMA SAR>**

Plot No.	Band	Mode	Test Position	Gap (mm)	Power Mode	Ch.	Freq. (MHz)	Average Power (dBm)	Tune-Up Limit (dBm)	Tune-up Scaling Factor	Power Drift (dB)	Measured 10g SAR (W/kg)	Reported 10g SAR (W/kg)
36	WCDMA II	RMC 12.2Kbps	Back	0	Reduced	9400	1880	20.38	21.50	1.294	0.14	2.600	<b>3.365</b>
	WCDMA II	RMC 12.2Kbps	Back	0	Reduced	9262	1852.4	20.21	21.50	1.346	0.02	2.490	3.351
	WCDMA II	RMC 12.2Kbps	Back	0	Reduced	9538	1907.6	20.36	21.50	1.300	0.04	2.230	2.899
	WCDMA II	RMC 12.2Kbps	Bottom Side	0	Reduced	9400	1880	20.38	21.50	1.294	0.03	2.010	2.601
	WCDMA II	RMC 12.2Kbps	Bottom Side	0	Reduced	9262	1852.4	20.21	21.50	1.346	0.08	1.690	2.275
	WCDMA II	RMC 12.2Kbps	Bottom Side	0	Reduced	9538	1907.6	20.36	21.50	1.300	0.02	2.140	2.782
	WCDMA IV	RMC 12.2Kbps	Front	0	Reduced	1413	1732.6	20.35	21.00	1.161	0.09	1.440	1.672
	WCDMA IV	RMC 12.2Kbps	Back	0	Reduced	1413	1732.6	20.35	21.00	1.161	-0.02	2.700	3.136
	WCDMA IV	RMC 12.2Kbps	Back	0	Reduced	1312	1712.4	20.31	21.00	1.172	-0.04	2.420	2.837
	WCDMA IV	RMC 12.2Kbps	Back	0	Reduced	1513	1752.6	20.29	21.00	1.178	0.08	2.420	2.850
	WCDMA IV	RMC 12.2Kbps	Bottom Side	0	Reduced	1413	1732.6	20.35	21.00	1.161	-0.05	2.980	3.461
37	WCDMA IV	RMC 12.2Kbps	Bottom Side	0	Reduced	1312	1712.4	20.31	21.00	1.172	-0.05	2.960	<b>3.470</b>
	WCDMA IV	RMC 12.2Kbps	Bottom Side	0	Reduced	1513	1752.6	20.29	21.00	1.178	-0.04	2.810	3.309
	WCDMA V	RMC 12.2Kbps	Back	0	Full	4182	836.4	22.72	24.00	1.343	0.08	2.120	2.847
	WCDMA V	RMC 12.2Kbps	Back	0	Full	4132	826.4	22.63	24.00	1.371	0.03	2.100	2.879
38	WCDMA V	RMC 12.2Kbps	Back	0	Full	4233	846.6	22.58	24.00	1.387	0.05	2.140	<b>2.968</b>



<LTE SAR>

Plot No.	Band	BW (MHz)	Modulation	RB Size	RB Offset	Test Position	Gap (mm)	Power Mode	Ch.	Freq. (MHz)	Average Power (dBm)	Tune-Up Limit (dBm)	Tune-up Scaling Factor	Power Drift (dB)	Measured 10g SAR (W/kg)	Reported 10g SAR (W/kg)
	LTE Band 2	20M	QPSK	1	0	Front	0	Reduced	18900	1880	19.93	21.00	1.279	0.08	0.894	1.144
	LTE Band 2	20M	QPSK	50	0	Front	0	Reduced	18900	1880	19.66	21.00	1.361	0.12	0.862	1.174
	LTE Band 2	20M	QPSK	1	0	Back	0	Reduced	18900	1880	19.93	21.00	1.279	0.04	2.250	2.879
	LTE Band 2	20M	QPSK	1	0	Back	0	Reduced	18700	1860	19.86	21.00	1.300	0.07	2.460	3.198
	LTE Band 2	20M	QPSK	1	0	Back	0	Reduced	19100	1900	19.67	21.00	1.358	-0.06	2.100	2.852
	LTE Band 2	20M	QPSK	50	0	Back	0	Reduced	18900	1880	19.66	21.00	1.361	0.05	2.180	2.968
39	LTE Band 2	20M	QPSK	50	0	Back	0	Reduced	18700	1860	19.30	21.00	1.479	0.08	2.290	3.387
	LTE Band 2	20M	QPSK	50	0	Back	0	Reduced	19100	1900	19.39	21.00	1.449	0.01	2.070	2.999
	LTE Band 2	20M	QPSK	100	0	Back	0	Reduced	18900	1880	19.60	21.00	1.380	0.06	2.140	2.954
	LTE Band 2	20M	QPSK	1	0	Bottom Side	0	Reduced	18900	1880	19.93	21.00	1.279	0.02	1.670	2.137
	LTE Band 2	20M	QPSK	1	0	Bottom Side	0	Reduced	18700	1860	19.86	21.00	1.300	-0.05	1.260	1.638
	LTE Band 2	20M	QPSK	1	0	Bottom Side	0	Reduced	19100	1900	19.67	21.00	1.358	0.03	1.710	2.323
	LTE Band 2	20M	QPSK	50	0	Bottom Side	0	Reduced	18900	1880	19.66	21.00	1.361	0.02	1.590	2.165
	LTE Band 2	20M	QPSK	50	0	Bottom Side	0	Reduced	18700	1860	19.30	21.00	1.479	0.06	1.250	1.849
	LTE Band 2	20M	QPSK	50	0	Bottom Side	0	Reduced	19100	1900	19.39	21.00	1.449	0.06	1.560	2.260
	LTE Band 2	20M	QPSK	100	0	Bottom Side	0	Reduced	18900	1880	19.60	21.00	1.380	0.02	1.700	2.347
40	LTE Band 5	10M	QPSK	1	0	Back	0	Full	20525	836.5	22.76	24.00	1.330	0.02	1.500	1.996
	LTE Band 5	10M	QPSK	25	0	Back	0	Full	20525	836.5	21.67	23.00	1.358	0.06	1.140	1.548
	LTE Band 7	20M	QPSK	1	99	Back	0	Reduced	20850	2510	20.50	21.50	1.259	0.08	2.390	3.009
	LTE Band 7	20M	QPSK	1	99	Back	0	Reduced	21100	2535	20.14	21.50	1.368	-0.07	2.320	3.173
	LTE Band 7	20M	QPSK	1	99	Back	0	Reduced	21350	2560	20.19	21.50	1.352	0.03	2.360	3.191
	LTE Band 7	20M	QPSK	50	50	Back	0	Reduced	20850	2510	20.35	21.50	1.303	0.02	2.460	3.206
	LTE Band 7	20M	QPSK	50	50	Back	0	Reduced	21100	2535	20.13	21.50	1.371	0.06	2.490	3.413
41	LTE Band 7	20M	QPSK	50	50	Back	0	Reduced	21350	2560	20.07	21.50	1.390	0.09	2.490	3.461
	LTE Band 7	20M	QPSK	100	0	Back	0	Reduced	20850	2510	20.21	21.50	1.346	0.03	2.460	3.311
	LTE Band 7	20M	QPSK	1	99	Bottom Side	0	Reduced	20850	2510	20.50	21.50	1.259	0.16	1.400	1.762
	LTE Band 7	20M	QPSK	50	50	Bottom Side	0	Reduced	20850	2510	20.35	21.50	1.303	0.02	1.460	1.903
	LTE Band 66	20M	QPSK	1	0	Front	0	Reduced	132072	1720	21.25	22.00	1.189	0.09	1.410	1.676
	LTE Band 66	20M	QPSK	50	0	Front	0	Reduced	132072	1720	21.10	22.00	1.230	0.03	1.360	1.673
	LTE Band 66	20M	QPSK	1	0	Back	0	Reduced	132072	1720	21.25	22.00	1.189	0.06	2.070	2.460
	LTE Band 66	20M	QPSK	1	0	Back	0	Reduced	132322	1745	21.11	22.00	1.227	0.01	1.930	2.369
	LTE Band 66	20M	QPSK	1	0	Back	0	Reduced	132572	1770	21.03	22.00	1.250	0.02	1.840	2.300
	LTE Band 66	20M	QPSK	50	0	Back	0	Reduced	132072	1720	21.10	22.00	1.230	0.05	1.950	2.399
	LTE Band 66	20M	QPSK	50	0	Back	0	Reduced	132322	1745	20.91	22.00	1.285	0.03	1.820	2.339
	LTE Band 66	20M	QPSK	50	0	Back	0	Reduced	132572	1770	20.94	22.00	1.276	0.07	1.730	2.208
	LTE Band 66	20M	QPSK	100	0	Back	0	Reduced	132072	1720	21.08	22.00	1.236	0.06	1.900	2.348
	LTE Band 66	20M	QPSK	1	0	Bottom Side	0	Reduced	132072	1720	21.25	22.00	1.189	0.18	2.700	3.209
	LTE Band 66	20M	QPSK	1	0	Bottom Side	0	Reduced	132322	1745	21.11	22.00	1.227	0.15	2.760	3.388
	LTE Band 66	20M	QPSK	1	0	Bottom Side	0	Reduced	132572	1770	21.03	22.00	1.250	-0.03	2.260	2.826
	LTE Band 66	20M	QPSK	50	0	Bottom Side	0	Reduced	132072	1720	21.10	22.00	1.230	0.08	2.680	3.297
42	LTE Band 66	20M	QPSK	50	0	Bottom Side	0	Reduced	132322	1745	20.91	22.00	1.285	0.02	2.670	3.432
	LTE Band 66	20M	QPSK	50	0	Bottom Side	0	Reduced	132572	1770	20.94	22.00	1.276	0.03	2.470	3.153
	LTE Band 66	20M	QPSK	100	0	Bottom Side	0	Reduced	132072	1720	21.08	22.00	1.236	0.02	2.670	3.300



**15.5 Repeated SAR Measurement**

**<1g SAR>**

No.	Band	Mode	BW (MHz)	Modulation	RB Size	RB Offset	Test Position	Gap (mm)	Headset	Power Mode	Ch.	Freq. (MHz)	Average Power (dBm)	Tune-Up Limit (dBm)	Tune-up Scaling Factor	Duty Cycle %	Duty Cycle Scaling Factor	Power Drift (dB)	Measured 1g SAR (W/kg)	Ratio	Reported 1g SAR (W/kg)
1st	WLAN2.4GHz	802.11b 1Mbps	-	-	-	-	Left Cheek	0	-	Full	1	2412	18.93	19.50	1.140	98.63	1.014	-0.07	0.888	1	1.027
2nd	WLAN2.4GHz	802.11b 1Mbps	-	-	-	-	Left Cheek	0	-	Full	1	2412	18.93	19.50	1.140	98.63	1.014	0.02	0.879	1.010	1.016
1st	GSM850	GPRS 2 Tx slots	-	-	-	-	Back	5	-	Reduced	251	848.8	29.37	30.00	1.156	-	1.000	-0.04	1.200	1	1.387
2nd	GSM850	GPRS 2 Tx slots	-	-	-	-	Back	5	-	Reduced	251	848.8	29.37	30.00	1.156	-	1.000	0.04	1.170	1.026	1.353
1st	GSM1900	GPRS 2 Tx slots	-	-	-	-	Back	5	-	Reduced	661	1880	23.12	24.00	1.225	-	1.000	-0.15	1.150	1	1.408
2nd	GSM1900	GPRS 2 Tx slots	-	-	-	-	Back	5	-	Reduced	661	1880	23.12	24.00	1.225	-	1.000	0.03	1.140	1.009	1.396
1st	LTE Band 7	-	20M	QPSK	50	50	Back	5	-	Reduced	21350	2560	17.75	19.00	1.334	-	1.000	0.01	1.000	1	1.334
2nd	LTE Band 7	-	20M	QPSK	50	50	Back	5	-	Reduced	21350	2560	17.75	19.00	1.334	-	1.000	-0.03	0.960	1.042	1.280
1st	WCDMA IV	RMC 12.2Kbps	-	-	-	-	Back	5	Headset	Reduced	1413	1732.6	14.12	15.50	1.374	-	1.000	0.09	1.050	1	1.443
2nd	WCDMA IV	RMC 12.2Kbps	-	-	-	-	Back	5	Headset	Reduced	1413	1732.6	14.12	15.50	1.374	-	1.000	-0.02	1.030	1.019	1.415

**<10g SAR>**

No.	Band	Mode	BW (MHz)	Modulation	RB Size	RB Offset	Test Position	Gap (mm)	Power Mode	Ch.	Freq. (MHz)	Average Power (dBm)	Tune-Up Limit (dBm)	Tune-up Scaling Factor	Duty Cycle %	Duty Cycle Scaling Factor	Power Drift (dB)	Measured 10g SAR (W/kg)	Ratio	Reported 10g SAR (W/kg)
1st	GSM1900	GPRS 2 Tx slots	-	-	-	-	Back	0	Full	512	1850.2	27.58	28.50	1.236	1.000	1.000	0.04	2.640	1	3.263
2nd	GSM1900	GPRS 2 Tx slots	-	-	-	-	Back	0	Full	512	1850.2	27.58	28.50	1.236	1.000	1.000	-0.02	2.600	1.015	3.213
1st	WCDMA IV	RMC 12.2Kbps	-	-	-	-	Bottom Side	0	Reduced	1312	1712.4	20.31	21.00	1.172	1.000	1.000	-0.05	2.960	1	3.470
2nd	WCDMA IV	RMC 12.2Kbps	-	-	-	-	Bottom Side	0	Reduced	1312	1712.4	20.31	21.00	1.172	1.000	1.000	0.06	2.940	1.007	3.446
1st	WCDMA V	RMC 12.2Kbps	-	-	-	-	Back	0	Full	4233	846.6	22.58	24.00	1.387	1.000	1.000	0.05	2.140	1	2.968
2nd	WCDMA V	RMC 12.2Kbps	-	-	-	-	Back	0	Full	4233	846.6	22.58	24.00	1.387	1.000	1.000	-0.02	2.130	1.005	2.954
1st	LTE Band 7	-	20M	QPSK	50	50	Back	0	Reduced	21350	2560	20.07	21.50	1.390	1.000	1.000	0.09	2.490	1	3.461
2nd	LTE Band 7	-	20M	QPSK	50	50	Back	0	Reduced	21350	2560	20.07	21.50	1.390	1.000	1.000	-0.002	2.460	1.012	3.419

**General Note:**

1. Per KDB 865664 D01v01r04, for each frequency band, repeated SAR measurement is required only when the measured SAR is  $\geq 0.8W/kg$ .
2. Per KDB 865664 D01v01r04, if the ratio among the repeated measurement is  $\leq 1.2$  and the measured SAR  $< 1.45W/kg$ , only one repeated measurement is required.
3. Per KDB 865664 D01v01r04, if the extremity repeated SAR is necessary, the same procedures should be adapted for measurements according to extremity and occupational exposure limits by applying a factor of 2.5 for extremity exposure and a factor of 5 for occupational exposure to the corresponding SAR thresholds.
4. The ratio is the difference in percentage between original and repeated *measured SAR*.
5. All measurement SAR result is scaled-up to account for tune-up tolerance and is compliant.

## 16. Simultaneous Transmission Analysis

No.	Simultaneous Transmission Configurations	Portable Handset			
		Head	Body-worn	Hotspot	Product specific 10g SAR
1.	GSM Voice + WLAN2.4GHz	Yes	Yes		
2.	GPRS/EDGE + WLAN2.4GHz	Yes	Yes	Yes	Yes
3.	WCDMA + WLAN2.4GHz	Yes	Yes	Yes	Yes
4.	LTE + WLAN2.4GHz	Yes	Yes	Yes	Yes
5.	GSM Voice + Bluetooth	Yes	Yes		
6.	GPRS/EDGE + Bluetooth	Yes	Yes	Yes	Yes
7.	WCDMA + Bluetooth	Yes	Yes	Yes	Yes
8.	LTE + Bluetooth	Yes	Yes	Yes	Yes

### General Note:

1. This device supports VoIP in GPRS, EGPRS, WCDMA and LTE (e.g. for 3rd-party VoIP), LTE supports VoLTE operation.
2. EUT will choose each GSM, WCDMA and LTE according to the network signal condition; therefore, they will not operate simultaneously at any moment.
3. This device 2.4GHz WLAN support hotspot operation and Bluetooth support tethering applications.
4. WLAN 2.4GHz and Bluetooth share the same antenna so can't transmit simultaneously.
5. The reported SAR summation is calculated based on the same configuration and test position.
6. Per KDB 447498 D01v06, simultaneous transmission SAR is compliant if,
  - i) 1g Scalar SAR summation < 1.6W/kg and 10g Scalar SAR summation < 4.0W/kg.
  - ii)  $SPLSR = (SAR1 + SAR2)^{1.5} / (\text{min. separation distance, mm})$ , and the peak separation distance is determined from the square root of  $[(x1-x2)^2 + (y1-y2)^2 + (z1-z2)^2]$ , where (x1, y1, z1) and (x2, y2, z2) are the coordinates of the extrapolated peak SAR locations in the zoom scan.
  - iii) If  $SPLSR \leq 0.04$  for 1g SAR and  $SPLSR \leq 0.10$  for 10g SAR, simultaneously transmission SAR measurement is not necessary.
  - iv) Simultaneously transmission SAR measurement, and the reported multi-band 1g SAR < 1.6W/kg and 10g SAR < 4.0W/kg.
  - v) The SPLSR calculated results please refer to section 16.4.



**16.1 Head Exposure Conditions**

WWAN Band		Exposure Position	1	2	3	1+2		1+3 Summed 1g SAR (W/kg)	
			WWAN	2.4GHz WLAN	Bluetooth	Summed 1g SAR (W/kg)	Case No		SPLSR
			1g SAR (W/kg)	1g SAR (W/kg)	1g SAR (W/kg)				
GSM	GSM850	Right Cheek	0.554	0.317	0.019	0.87			0.57
		Right Tilted	0.291	0.247	0.015	0.54			0.31
		Left Cheek	0.536	1.027	0.045	1.56			0.58
		Left Tilted	0.292	0.770	0.043	1.06			0.34
	GSM1900	Right Cheek	0.154	0.317	0.019	0.47			0.17
		Right Tilted	0.114	0.247	0.015	0.36			0.13
		Left Cheek	0.123	1.027	0.045	1.15			0.17
		Left Tilted	0.094	0.770	0.043	0.86			0.14
WCDMA	WCDMA II	Right Cheek	0.290	0.317	0.019	0.61			0.31
		Right Tilted	0.233	0.247	0.015	0.48			0.25
		Left Cheek	0.232	1.027	0.045	1.26			0.28
		Left Tilted	0.172	0.770	0.043	0.94			0.22
	WCDMA IV	Right Cheek	0.171	0.317	0.019	0.49			0.19
		Right Tilted	0.116	0.247	0.015	0.36			0.13
		Left Cheek	0.108	1.027	0.045	1.14			0.15
		Left Tilted	0.088	0.770	0.043	0.86			0.13
	WCDMA V	Right Cheek	0.541	0.317	0.019	0.86			0.56
		Right Tilted	0.267	0.247	0.015	0.51			0.28
		Left Cheek	0.498	1.027	0.045	1.53			0.54
		Left Tilted	0.246	0.770	0.043	1.02			0.29
LTE	LTE Band 2	Right Cheek	0.285	0.317	0.019	0.60			0.30
		Right Tilted	0.234	0.247	0.015	0.48			0.25
		Left Cheek	0.275	1.027	0.045	1.30			0.32
		Left Tilted	0.181	0.770	0.043	0.95			0.22
	LTE Band 5	Right Cheek	0.808	0.317	0.019	1.13			0.83
		Right Tilted	0.359	0.247	0.015	0.61			0.37
		Left Cheek	0.808	1.027	0.045	1.84	#01	0.03	0.85
		Left Tilted	0.415	0.770	0.043	1.19			0.46
	LTE Band 7	Right Cheek	0.149	0.317	0.019	0.47			0.17
		Right Tilted	0.054	0.247	0.015	0.30			0.07
		Left Cheek	0.230	1.027	0.045	1.26			0.28
		Left Tilted	0.095	0.770	0.043	0.87			0.14
	LTE Band 66	Right Cheek	0.120	0.317	0.019	0.44			0.14
		Right Tilted	0.062	0.247	0.015	0.31			0.08
		Left Cheek	0.043	1.027	0.045	1.07			0.09
		Left Tilted	0.052	0.770	0.043	0.82			0.10





16.2 Hotspot Exposure Conditions

WWAN Band		Exposure Position	1	2	3	1+2			1+3 Summed 1g SAR (W/kg)
			WWAN	2.4GHz WLAN	Bluetooth	Summed 1g SAR (W/kg)	Case No	SPLSR	
			1g SAR (W/kg)	1g SAR (W/kg)	1g SAR (W/kg)				
GSM	GSM850	Front	0.831	0.520	0.023	1.35			0.85
		Back	1.387	1.025	0.066	2.41	#02	0.03	1.45
		Left side	0.687			0.69			0.69
		Right side	0.701	0.712	0.046	1.41			0.75
		Top side		0.392	0.027	0.39			0.03
		Bottom side	0.326			0.33			0.33
	GSM1900	Front	0.399	0.520	0.023	0.92			0.42
		Back	1.408	1.025	0.066	2.43	#03	0.02	1.47
		Left side	0.080			0.08			0.08
		Right side	0.091	0.712	0.046	0.80			0.14
		Top side		0.392	0.027	0.39			0.03
		Bottom side	0.872			0.87			0.87
WCDMA	WCDMA II	Front	0.343	0.520	0.023	0.86			0.37
		Back	1.344	1.025	0.066	2.37	#04	0.02	1.41
		Left side	0.075			0.08			0.08
		Right side	0.085	0.712	0.046	0.80			0.13
		Top side		0.392	0.027	0.39			0.03
		Bottom side	1.021			1.02			1.02
	WCDMA IV	Front	0.414	0.520	0.023	0.93			0.44
		Back	1.374	1.025	0.066	2.40	#05	0.02	1.44
		Left side	0.045			0.05			0.05
		Right side	0.090	0.712	0.046	0.80			0.14
		Top side		0.392	0.027	0.39			0.03
		Bottom side	1.323			1.32			1.32
	WCDMA V	Front	0.677	0.520	0.023	1.20			0.70
		Back	1.298	1.025	0.066	2.32	#06	0.02	1.36
		Left side	0.655			0.66			0.66
		Right side	0.665	0.712	0.046	1.38			0.71
		Top side		0.392	0.027	0.39			0.03
		Bottom side	0.203			0.20			0.20
LTE	LTE Band 2	Front	0.404	0.520	0.023	0.92			0.43
		Back	1.385	1.025	0.066	2.41	#07	0.02	1.45
		Left side	0.089			0.09			0.09
		Right side	0.077	0.712	0.046	0.79			0.12
		Top side		0.392	0.027	0.39			0.03
		Bottom side	0.910			0.91			0.91
	LTE Band 5	Front	0.673	0.520	0.023	1.19			0.70
		Back	1.384	1.025	0.066	2.41	#08	0.03	1.45
		Left side	0.753			0.75			0.75
		Right side	0.785	0.712	0.046	1.50			0.83
		Top side		0.392	0.027	0.39			0.03
		Bottom side	0.228			0.23			0.23
	LTE Band 7	Front	0.380	0.520	0.023	0.90			0.40
		Back	1.334	1.025	0.066	2.36	#09	0.02	1.40
		Left side	0.132			0.13			0.13
		Right side	0.175	0.712	0.046	0.89			0.22
		Top side		0.392	0.027	0.39			0.03
		Bottom side	0.781			0.78			0.78



WWAN Band		Exposure Position	1	2	3	1+2			1+3 Summed 1g SAR (W/kg)
			WWAN	2.4GHz WLAN	Bluetooth	Summed 1g SAR (W/kg)	Case No	SPLSR	
			1g SAR (W/kg)	1g SAR (W/kg)	1g SAR (W/kg)				
LTE	LTE Band 66	Front	0.404	0.520	0.023	0.92			0.43
		Back	1.305	1.025	0.066	<b>2.33</b>	<b>#10</b>	<b>0.02</b>	1.37
		Left side	0.043			0.04			0.04
		Right side	0.080	0.712	0.046	0.79			0.13
		Top side		0.392	0.027	0.39			0.03
		Bottom side	1.181			1.18			1.18

**16.3 Body-Worn Accessory Exposure Conditions**

WWAN Band		Exposure Position	1	2	3	1+2		1+3 Summed 1g SAR (W/kg)	
			WWAN	2.4GHz WLAN	Bluetooth	Summed 1g SAR (W/kg)	Case No		SPLSR
			1g SAR (W/kg)	1g SAR (W/kg)	1g SAR (W/kg)				
GSM	GSM850	Front	0.831	0.520	0.023	1.35			0.85
		Back	1.387	1.025	0.066	<b>2.41</b>	<b>#02</b>	<b>0.03</b>	1.45
		Back with Headset	1.237			1.24			1.24
	GSM1900	Front	0.399	0.520	0.023	0.92			0.42
		Back	1.408	1.025	0.066	<b>2.43</b>	<b>#03</b>	<b>0.02</b>	1.47
		Back with Headset	1.335			1.34			1.34
WCDMA	WCDMA II	Front	0.343	0.520	0.023	0.86			0.37
		Back	1.344	1.025	0.066	<b>2.37</b>	<b>#04</b>	<b>0.02</b>	1.41
		Back with Headset	1.304			1.30			1.30
	WCDMA IV	Front	0.414	0.520	0.023	0.93			0.44
		Back	1.374	1.025	0.066	<b>2.40</b>	<b>#05</b>	<b>0.02</b>	1.44
		Back with Headset	1.443			1.44			1.44
	WCDMA V	Front	0.677	0.520	0.023	1.20			0.70
		Back	1.298	1.025	0.066	<b>2.32</b>	<b>#06</b>	<b>0.02</b>	1.36
		Back with Headset	1.219			1.22			1.22
LTE	LTE Band 2	Front	0.404	0.520	0.023	0.92			0.43
		Back	1.385	1.025	0.066	<b>2.41</b>	<b>#07</b>	<b>0.02</b>	1.45
		Back with Headset	1.309			1.31			1.31
	LTE Band 5	Front	0.673	0.520	0.023	1.19			0.70
		Back	1.384	1.025	0.066	<b>2.41</b>	<b>#08</b>	<b>0.03</b>	1.45
		Back with Headset	1.357			1.36			1.36
	LTE Band 7	Front	0.380	0.520	0.023	0.90			0.40
		Back	1.334	1.025	0.066	<b>2.36</b>	<b>#09</b>	<b>0.02</b>	1.40
		Back with Headset	1.320			1.32			1.32
	LTE Band 66	Front	0.404	0.520	0.023	0.92			0.43
		Back	1.305	1.025	0.066	<b>2.33</b>	<b>#10</b>	<b>0.02</b>	1.37
		Back with Headset	1.059			1.06			1.06

### 16.4 SPLSR Evaluation and Analysis

**General Note:**

1. When standalone SAR is measured for both antennas in the pair, the peak location separation distance is computed by the square root of  $[(x1-x2)^2 + (y1-y2)^2 + (z1-z2)^2]$ , where (x1, y1, z1) and (x2, y2, z2) are the coordinates in the area scans or extrapolated peak SAR locations in the zoom scans, as appropriate.
2.  $SPLSR = (SAR1 + SAR2)1.5 / (\text{min. separation distance, mm})$ . If  $SPLSR \leq 0.04$  for 1g SAR and  $SPLSR \leq 0.10$  for 10g SAR, simultaneously transmission SAR measurement is not necessary.

Case #01	Band	Position	SAR (W/kg)	Gap (mm)	SAR peak location (mm)			3D distance (mm)	Summed SAR (W/kg)	SPLSR Results	Simultaneous SAR
					X	Y	Z				
	LTE Band 5	Left Cheek	0.808	0mm	47.99	-39.86	-2.59	73.8	1.84	0.03	Not required
	WLAN2.4GHz		1.027	0mm	1.93	17.8	-0.24				

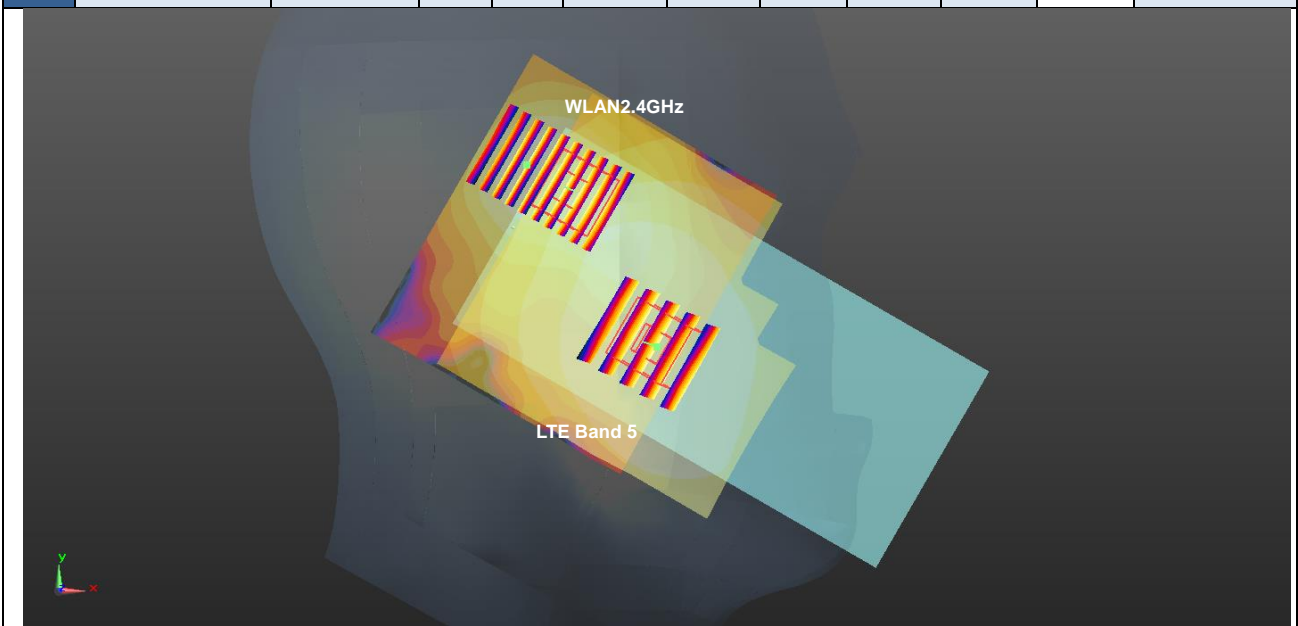

Case #02	Band	Position	SAR (W/kg)	Gap (mm)	SAR peak location (mm)			3D distance (mm)	Summed SAR (W/kg)	SPLSR Results	Simultaneous SAR
					X	Y	Z				
Case #02	GSM850 Cube0	Back	1.387	5mm	-6.3	-68.6	-1.86	144.2	2.41	0.03	Not required
	WLAN2.4GHz		1.025	5mm	-27.6	74	-0.68				
	GSM850 Cube1	Back	1.168	5mm	-8	-70.3	-1.85	145.6	2.19	0.02	Not required
	WLAN2.4GHz		1.025	5mm	-27.6	74	-0.68				

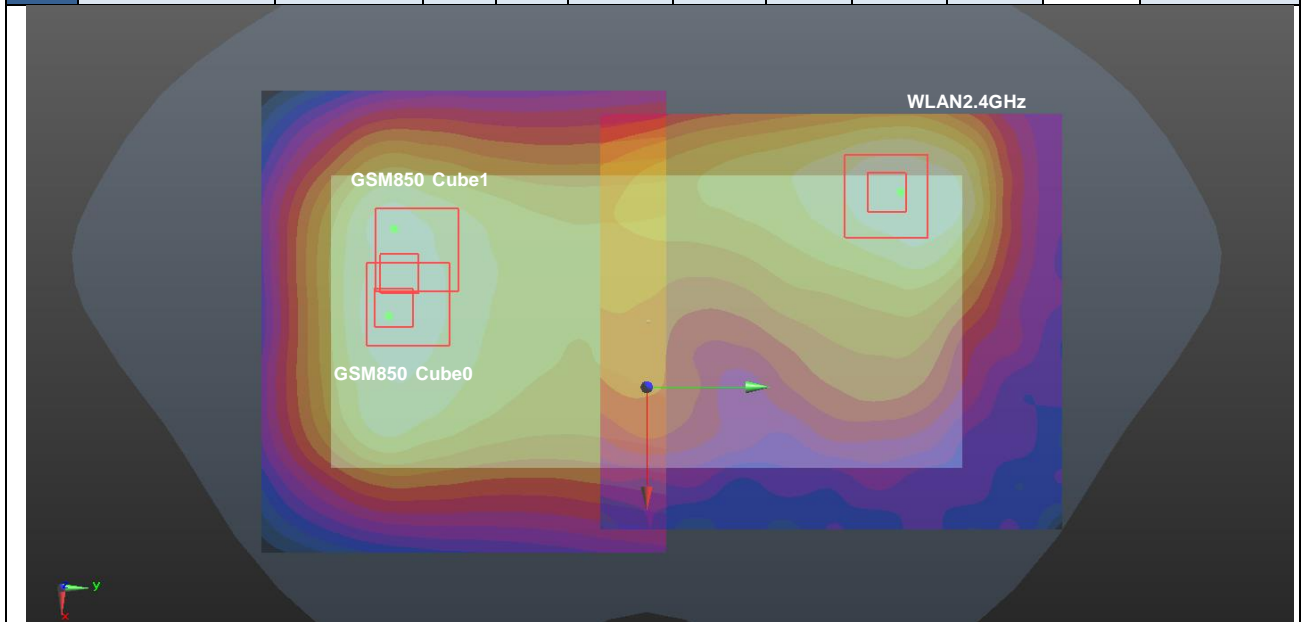

Case #03	Band	Position	SAR (W/kg)	Gap (mm)	SAR peak location (mm)			3D distance (mm)	Summed SAR (W/kg)	SPLSR Results	Simultaneous SAR
					X	Y	Z				
	GSM1900	Back	1.408	5mm	11.9	-75.9	-0.75	155.0	2.43	0.02	Not required
	WLAN2.4GHz		1.025	5mm	-27.6	74	-0.68				

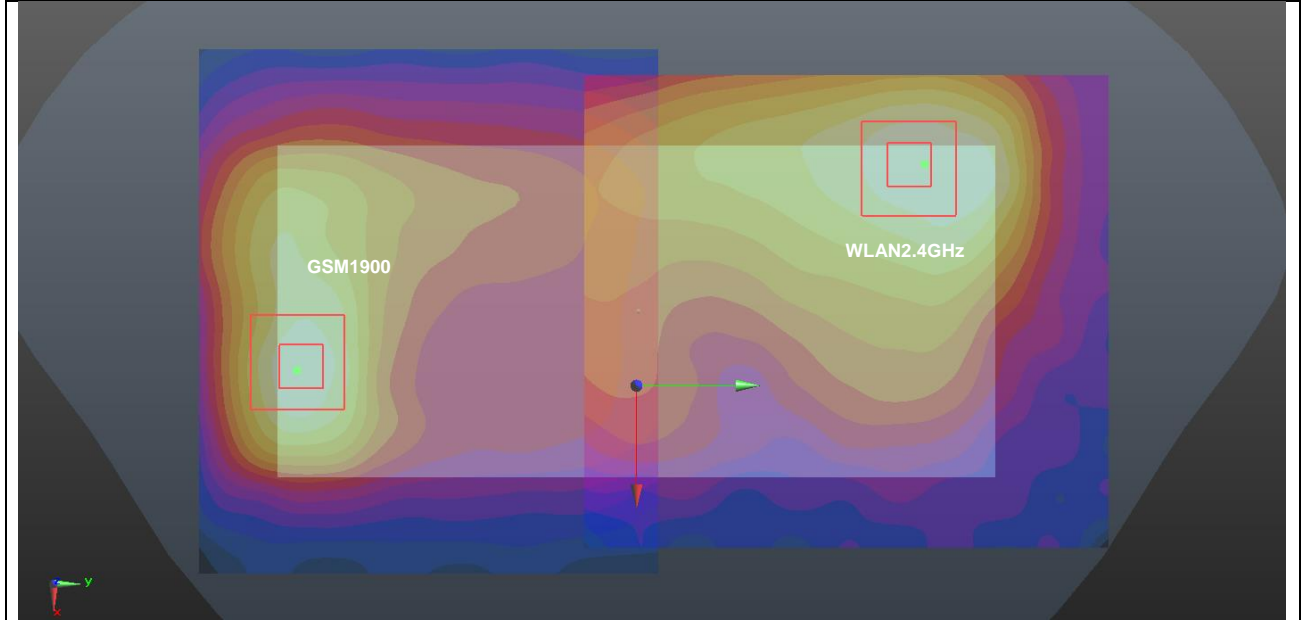

Case #04	Band	Position	SAR (W/kg)	Gap (mm)	SAR peak location (mm)			3D distance (mm)	Summed SAR (W/kg)	SPLSR Results	Simultaneous SAR
					X	Y	Z				
	WCDMA II	Back	1.344	5mm	10.5	-78	-0.77	156.7	2.37	0.02	Not required
	WLAN2.4GHz		1.025	5mm	-27.6	74	-0.68				

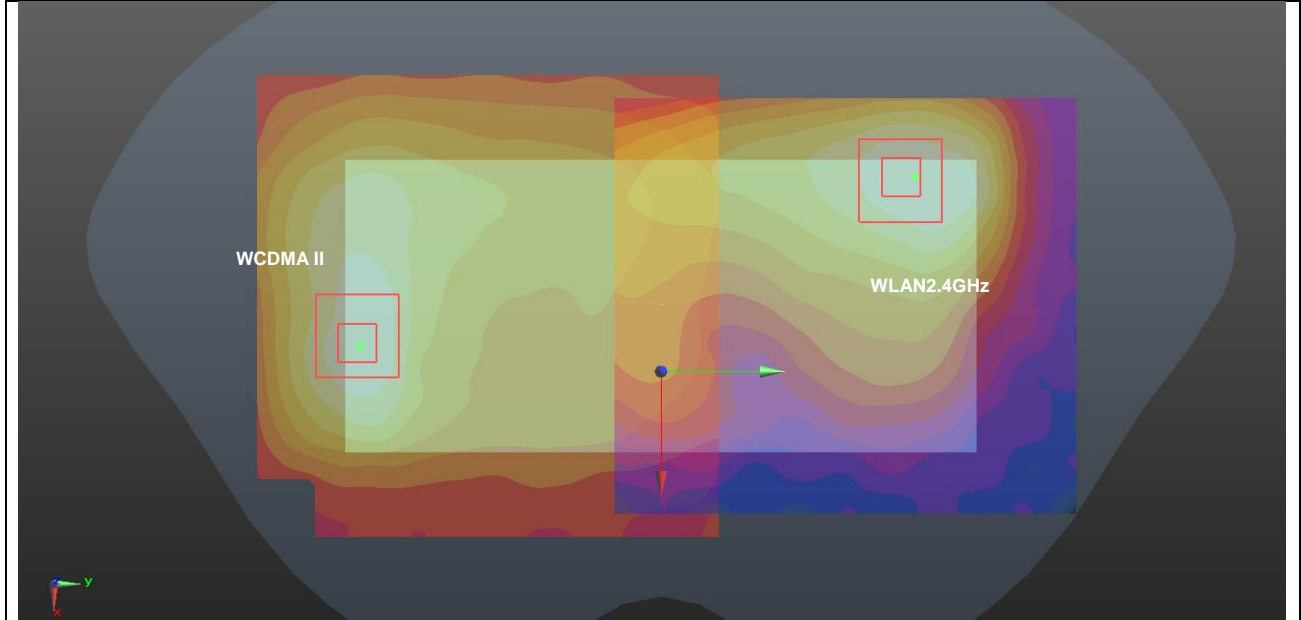

Case #05	Band	Position	SAR (W/kg)	Gap (mm)	SAR peak location (mm)			3D distance (mm)	Summed SAR (W/kg)	SPLSR Results	Simultaneous SAR
					X	Y	Z				
	WCDMA IV	Back	1.374	5mm	-16.7	-81.1	-0.77	155.5	2.40	0.02	Not required
	WLAN2.4GHz		1.025	5mm	-27.6	74	-0.68				

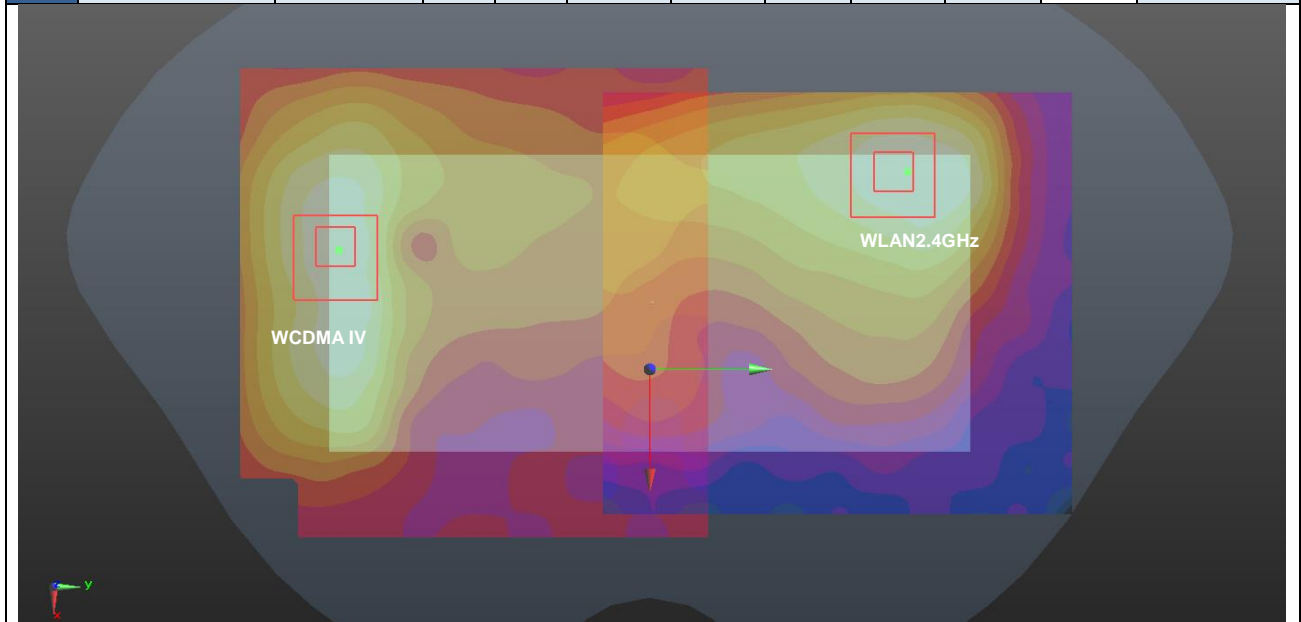



Case #06	Band	Position	SAR (W/kg)	Gap (mm)	SAR peak location (mm)			3D distance (mm)	Summed SAR (W/kg)	SPLSR Results	Simultaneous SAR
					X	Y	Z				
Case #06	WCDMA V Cube0	Back	1.298	5mm	-10.8	-70.2	-1.08	145.2	2.32	0.02	Not required
	WLAN2.4GHz		1.025	5mm	-27.6	74	-0.68				
	WCDMA V Cube1	Back	1.067	5mm	-15.5	-71.8	-1.05	146.3	2.09	0.02	Not required
	WLAN2.4GHz		1.025	5mm	-27.6	74	-0.68				

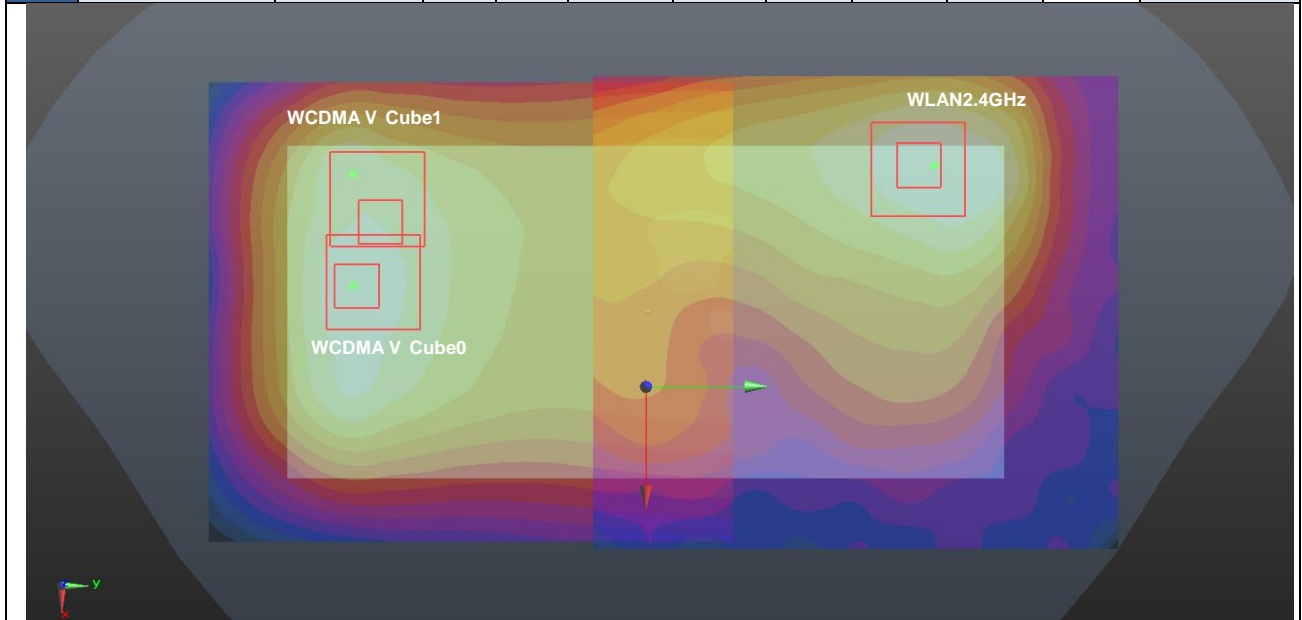

Case #07	Band	Position	SAR (W/kg)	Gap (mm)	SAR peak location (mm)			3D distance (mm)	Summed SAR (W/kg)	SPLSR Results	Simultaneous SAR
					X	Y	Z				
	LTE Band 2	Back	1.385	5mm	8.8	-76.6	-1.61	154.9	2.41	0.02	Not required
	WLAN2.4GHz		1.025	5mm	-27.6	74	-0.68				

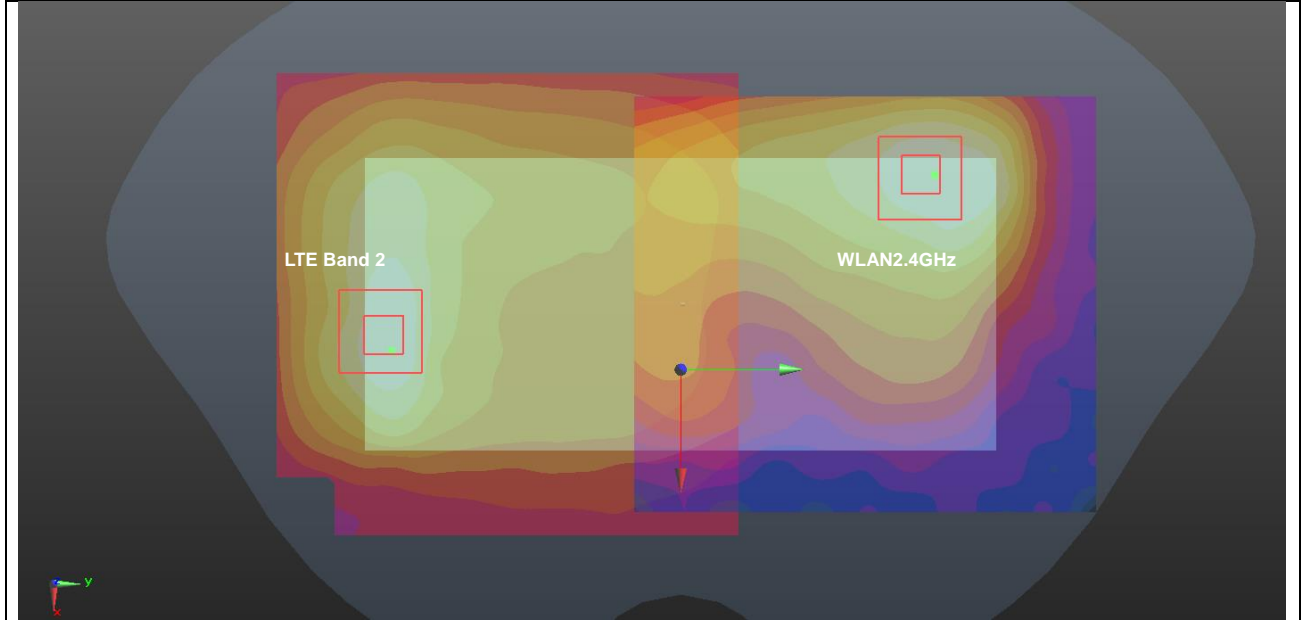

Case #08	Band	Position	SAR (W/kg)	Gap (mm)	SAR peak location (mm)			3D distance (mm)	Summed SAR (W/kg)	SPLSR Results	Simultaneous SAR
					X	Y	Z				
	LTE Band 5	Back	1.384	5mm	0.2	-72.1	-0.98	148.7	2.41	0.03	Not required
	WLAN2.4GHz		1.025	5mm	-27.6	74	-0.68				

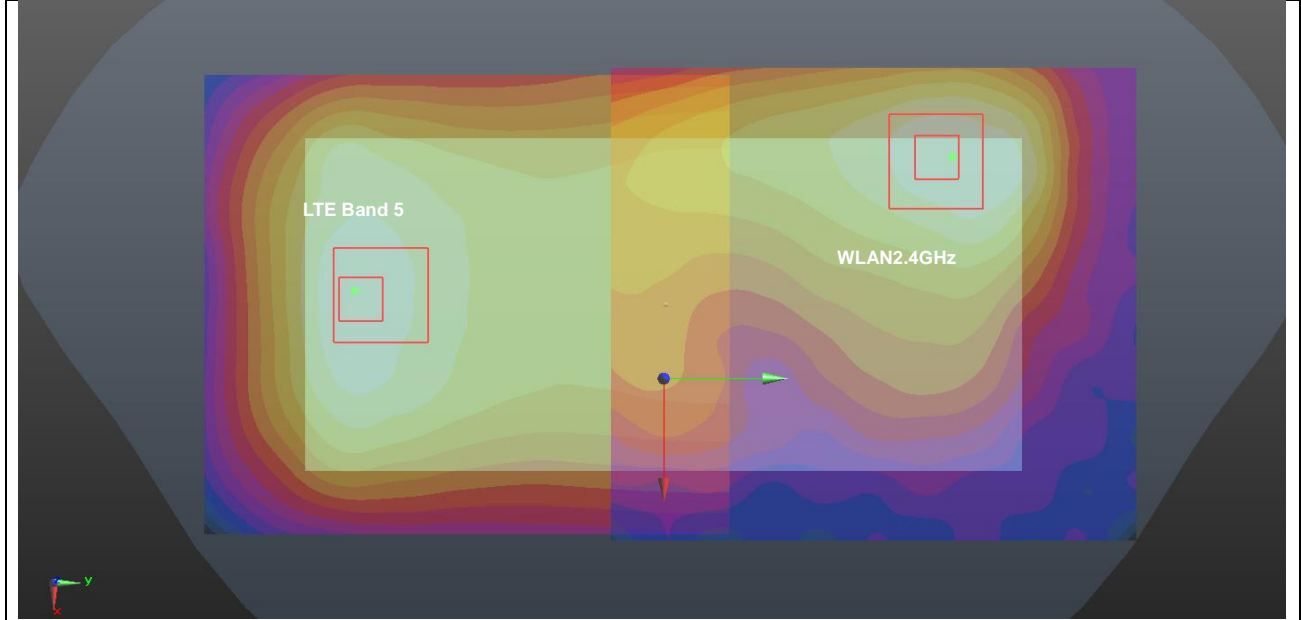

Case #09	Band	Position	SAR (W/kg)	Gap (mm)	SAR peak location (mm)			3D distance (mm)	Summed SAR (W/kg)	SPLSR Results	Simultaneous SAR
					X	Y	Z				
	LTE Band 7	Back	1.334	5mm	8	-72.6	-1.45	150.9	2.36	0.02	Not required
	WLAN2.4GHz		1.025	5mm	-27.6	74	-0.68				

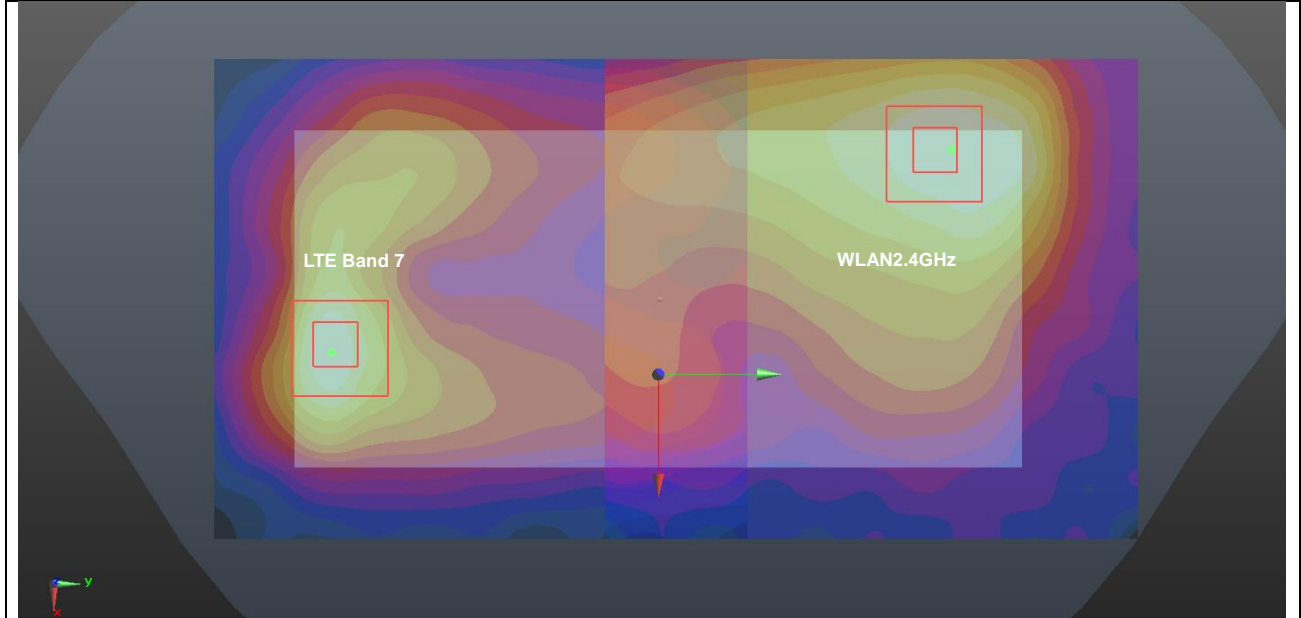

Case #10	Band	Position	SAR (W/kg)	Gap (mm)	SAR peak location (mm)			3D distance (mm)	Summed SAR (W/kg)	SPLSR Results	Simultaneous SAR
					X	Y	Z				
	LTE Band 66	Back	1.305	5mm	-14.5	-82.7	-0.74	157.2	2.33	0.02	Not required
	WLAN2.4GHz		1.025	5mm	-27.6	74	-0.68				

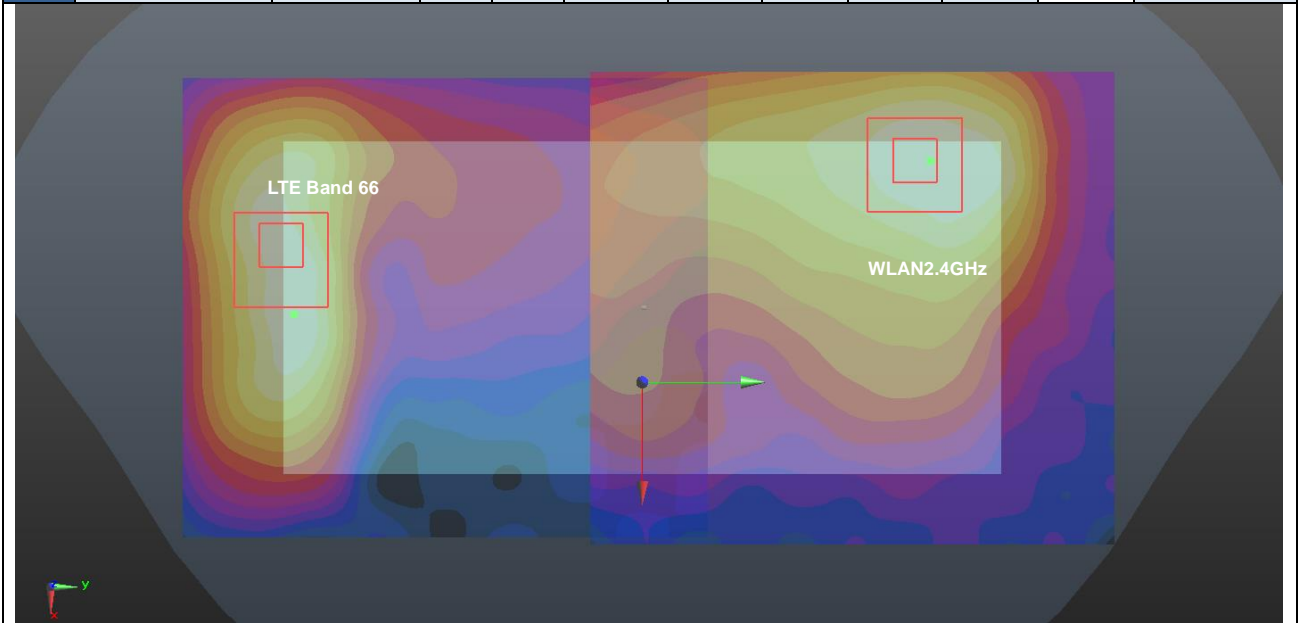

**Test Engineer:** Nick Hu, Yuan Zhao, Jiaxing Chang, Yuankai Kong



## **17. Uncertainty Assessment**

Per KDB 865664 D01 SAR measurement 100MHz to 6GHz, when the highest measured 1-g SAR within a frequency band is < 1.5 W/kg and the measured 10-g SAR within a frequency band is < 3.75 W/kg. The expanded SAR measurement uncertainty must be  $\leq 30\%$ , for a confidence interval of  $k = 2$ . If these conditions are met, extensive SAR measurement uncertainty analysis described in IEEE Std 1528-2013 is not required in SAR reports submitted for equipment approval. For this device, the highest measured 1-g SAR is less 1.5W/kg and highest measured 10-g SAR is less 3.75W/kg. Therefore, the measurement uncertainty table is not required in this report.

## 18. References

- [1] FCC 47 CFR Part 2 “Frequency Allocations and Radio Treaty Matters; General Rules and Regulations”
- [2] ANSI/IEEE Std. C95.1-1992, “IEEE Standard for Safety Levels with Respect to Human Exposure to Radio Frequency Electromagnetic Fields, 3 kHz to 300 GHz”, September 1992
- [3] IEEE Std. 1528-2013, “IEEE Recommended Practice for Determining the Peak Spatial-Average Specific Absorption Rate (SAR) in the Human Head from Wireless Communications Devices: Measurement Techniques”, Sep 2013
- [4] SPEAG DASY System Handbook
- [5] FCC KDB 865664 D01 v01r04, "SAR Measurement Requirements for 100 MHz to 6 GHz", Aug 2015.
- [6] FCC KDB 865664 D02 v01r02, “RF Exposure Compliance Reporting and Documentation Considerations” Oct 2015.
- [7] FCC KDB 447498 D01 v06, “Mobile and Portable Device RF Exposure Procedures and Equipment Authorization Policies”, Oct 2015
- [8] FCC KDB 648474 D04 v01r03, “SAR Evaluation Considerations for Wireless Handsets”, Oct 2015.
- [9] FCC KDB 248227 D01 v02r02, “SAR Guidance for IEEE 802.11 (WiFi) Transmitters”, Oct 2015.
- [10] FCC KDB 616217 D04 v01r02, “SAR Evaluation Considerations for Laptop, Notebook, Netbook and Tablet Computers”, Oct 2015
- [11] FCC KDB 941225 D01 v03r01, “3G SAR MEAUREMENT PROCEDURES”, Oct 2015
- [12] FCC KDB 941225 D05 v02r05, “SAR Evaluation Considerations for LTE Devices”, Dec 2015
- [13] FCC KDB 941225 D06 v02r01, "SAR Evaluation Procedures for Portable Devices with Wireless Router Capabilities", Oct 2015.

-----THE END-----



## **Appendix A. Plots of System Performance Check**

The plots are shown as follows.



**System Check\_Head\_835MHz**

**DUT: D835V2 - SN:4d151**

Communication System: UID 0, CW (0); Frequency: 835 MHz; Duty Cycle: 1:1

Medium: HSL\_850 Medium parameters used:  $f = 835 \text{ MHz}$ ;  $\sigma = 0.929 \text{ S/m}$ ;  $\epsilon_r = 42.225$ ;  $\rho = 1000 \text{ kg/m}^3$

Ambient Temperature :  $23.3 \text{ }^\circ\text{C}$ ; Liquid Temperature :  $22.7 \text{ }^\circ\text{C}$

DASY5 Configuration:

- Probe: EX3DV4 - SN3935; ConvF(10.48, 10.48, 10.48); Calibrated: 2018.11.26
- Sensor-Surface: 1.4mm (Mechanical Surface Detection)
- Electronics: DAE4 Sn690; Calibrated: 2019.1.23
- Phantom: SAM2; Type: SAM; Serial: TP-1754
- Measurement SW: DASY52, Version 52.10 (1); SEMCAD X Version 14.6.11 (7439)

**Pin=250mW/Area Scan (61x61x1):** Interpolated grid:  $dx=1.500 \text{ mm}$ ,  $dy=1.500 \text{ mm}$

Maximum value of SAR (interpolated) =  $3.28 \text{ W/kg}$

**Pin=250mW/Zoom Scan (5x5x7)/Cube 0:** Measurement grid:  $dx=8\text{mm}$ ,  $dy=8\text{mm}$ ,  $dz=5\text{mm}$

Reference Value =  $61.75 \text{ V/m}$ ; Power Drift =  $-0.04 \text{ dB}$

Peak SAR (extrapolated) =  $3.72 \text{ W/kg}$

**SAR(1 g) =  $2.46 \text{ W/kg}$ ; SAR(10 g) =  $1.61 \text{ W/kg}$**

Maximum value of SAR (measured) =  $3.30 \text{ W/kg}$

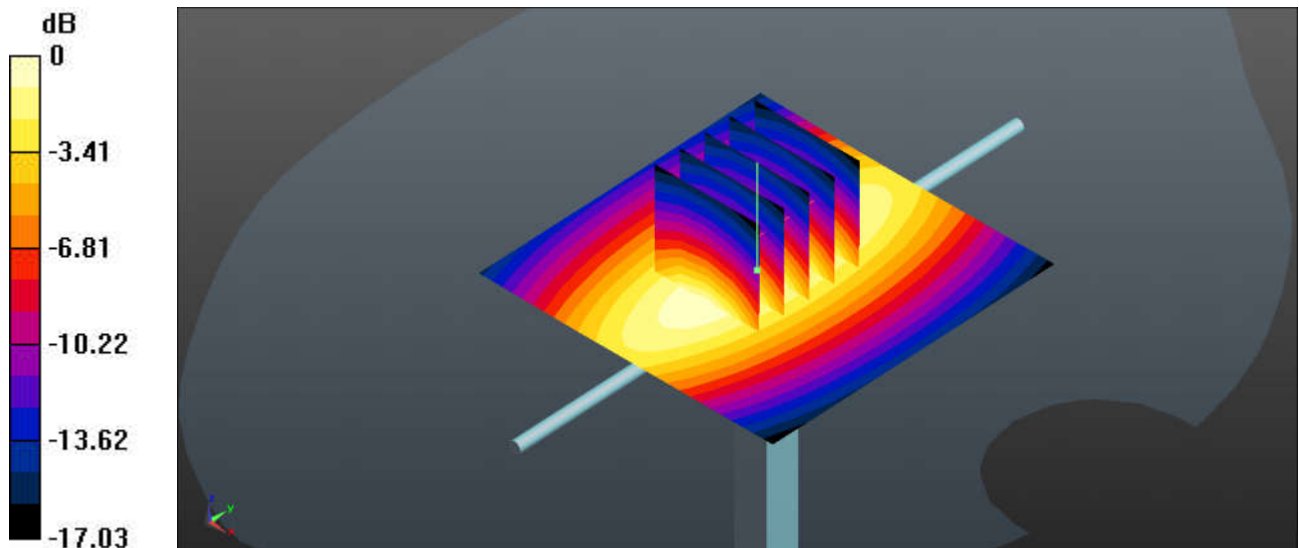

0 dB =  $3.28 \text{ W/kg} = 5.16 \text{ dBW/kg}$

### System Check\_Head\_1750MHz

**DUT: D1750V2 - SN:1090**

Communication System: UID 0, CW (0); Frequency: 1750 MHz; Duty Cycle: 1:1

Medium: HSL\_1750 Medium parameters used:  $f = 1750$  MHz;  $\sigma = 1.382$  S/m;  $\epsilon_r = 39.7$ ;  $\rho = 1000$  kg/m<sup>3</sup>

Ambient Temperature : 23.2 °C; Liquid Temperature : 22.9 °C

DASY5 Configuration:

- Probe: EX3DV4 - SN3935; ConvF(8.91, 8.91, 8.91); Calibrated: 2018.11.26
- Sensor-Surface: 1.4mm (Mechanical Surface Detection)
- Electronics: DAE4 Sn690; Calibrated: 2019.1.23
- Phantom: SAM2; Type: SAM; Serial: TP-1754
- Measurement SW: DASY52, Version 52.10 (1); SEMCAD X Version 14.6.11 (7439)

**Pin=250mW/Area Scan (61x61x1):** Interpolated grid: dx=1.500 mm, dy=1.500 mm

Maximum value of SAR (interpolated) = 14.2 W/kg

**Pin=250mW/Zoom Scan (5x5x7)/Cube 0:** Measurement grid: dx=8mm, dy=8mm, dz=5mm

Reference Value = 100.9 V/m; Power Drift = 0.01 dB

Peak SAR (extrapolated) = 16.4 W/kg

**SAR(1 g) = 9.34 W/kg; SAR(10 g) = 5.08 W/kg**

Maximum value of SAR (measured) = 13.9 W/kg

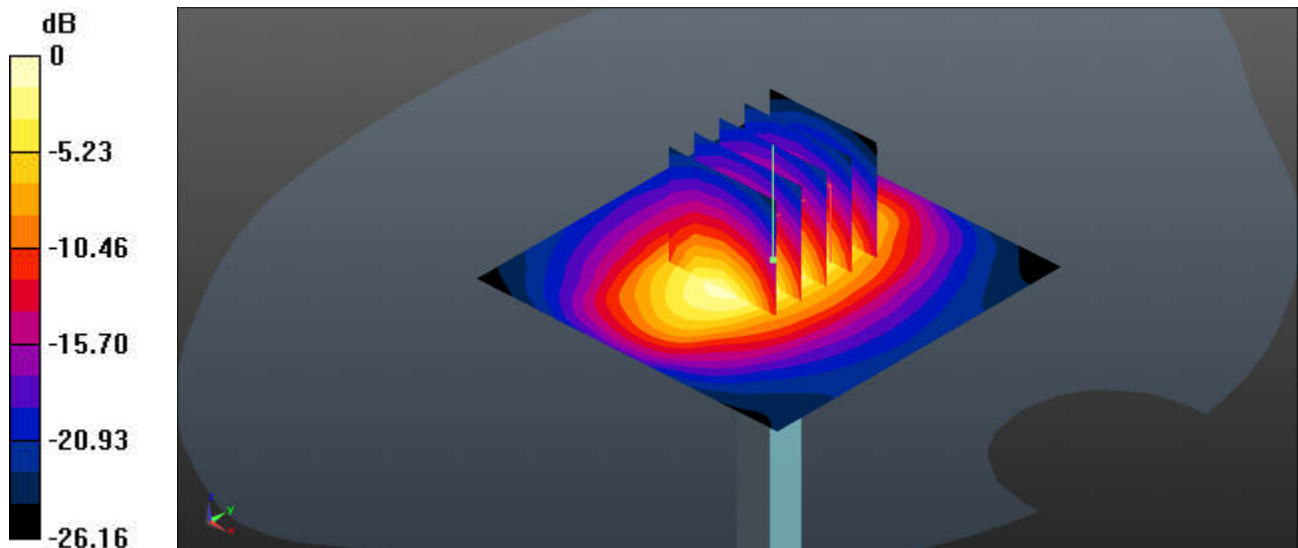

0 dB = 14.2 W/kg = 11.52 dBW/kg

**System Check\_Head\_1900MHz**

**DUT: D1900V2 - SN:5d170**

Communication System: UID 0, CW (0); Frequency: 1900 MHz; Duty Cycle: 1:1  
 Medium: HSL\_1900 Medium parameters used:  $f = 1900$  MHz;  $\sigma = 1.349$  S/m;  $\epsilon_r = 41.433$ ;  $\rho = 1000$  kg/m<sup>3</sup>  
 Ambient Temperature : 23.3 °C; Liquid Temperature : 22.7 °C

DASY5 Configuration:

- Probe: EX3DV4 - SN3935; ConvF(8.5, 8.5, 8.5); Calibrated: 2018.11.26
- Sensor-Surface: 1.4mm (Mechanical Surface Detection)
- Electronics: DAE4 Sn690; Calibrated: 2019.1.23
- Phantom: SAM2; Type: SAM; Serial: TP-1754
- Measurement SW: DASY52, Version 52.10 (1); SEMCAD X Version 14.6.11 (7439)

**Pin=250mW/Area Scan (61x61x1):** Interpolated grid: dx=1.500 mm, dy=1.500 mm  
 Maximum value of SAR (interpolated) = 13.9 W/kg

**Pin=250mW/Zoom Scan (5x5x7)/Cube 0:** Measurement grid: dx=8mm, dy=8mm, dz=5mm  
 Reference Value = 88.27 V/m; Power Drift = -0.02 dB  
 Peak SAR (extrapolated) = 17.6 W/kg  
**SAR(1 g) = 9.55 W/kg; SAR(10 g) = 4.98 W/kg**  
 Maximum value of SAR (measured) = 13.7 W/kg

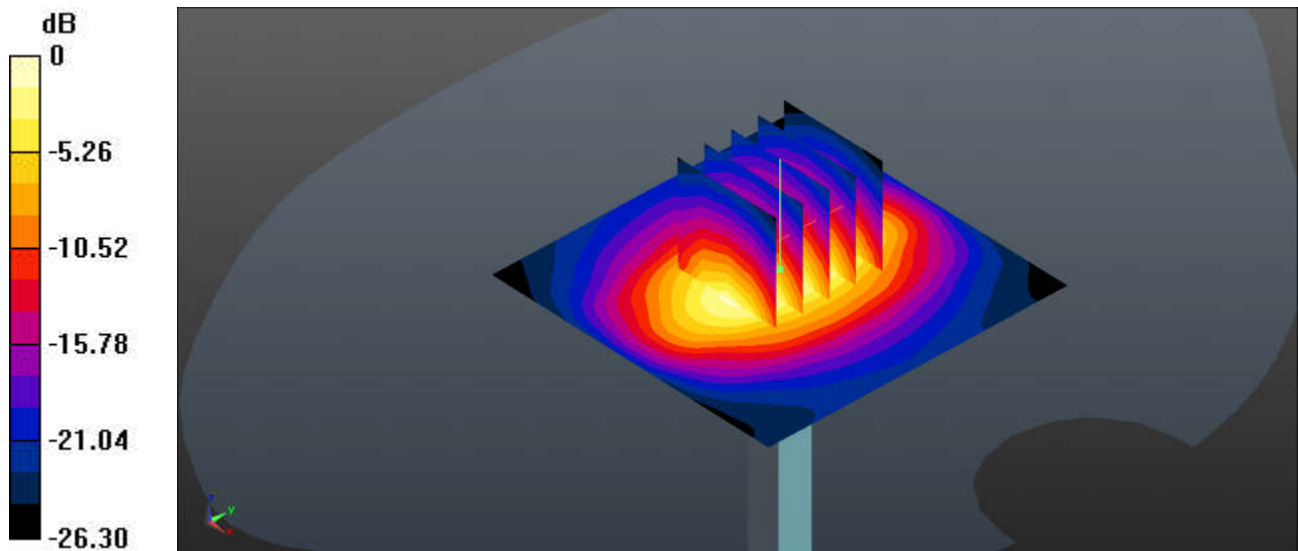

0 dB = 13.9 W/kg = 11.43 dBW/kg

### System Check\_Head\_2450MHz

#### DUT: D2450V2 - SN:908

Communication System: UID 0, CW (0); Frequency: 2450 MHz; Duty Cycle: 1:1

Medium: HSL\_2450 Medium parameters used:  $f = 2450$  MHz;  $\sigma = 1.808$  S/m;  $\epsilon_r = 38.325$ ;  $\rho = 1000$  kg/m<sup>3</sup>

Ambient Temperature : 23.2 °C; Liquid Temperature : 22.6 °C

#### DASY5 Configuration:

- Probe: EX3DV4 - SN3935; ConvF(7.69, 7.69, 7.69); Calibrated: 2018.11.26
- Sensor-Surface: 1.4mm (Mechanical Surface Detection)
- Electronics: DAE4 Sn690; Calibrated: 2019.1.23
- Phantom: SAM1; Type: SAM; Serial: TP-1753
- Measurement SW: DASY52, Version 52.10 (1); SEMCAD X Version 14.6.11 (7439)

**Pin=250mW/Area Scan (71x71x1):** Interpolated grid: dx=1.200 mm, dy=1.200 mm

Maximum value of SAR (interpolated) = 19.9 W/kg

**Pin=250mW/Zoom Scan (7x7x7)/Cube 0:** Measurement grid: dx=5mm, dy=5mm, dz=5mm

Reference Value = 83.43 V/m; Power Drift = 0.09 dB

Peak SAR (extrapolated) = 26.6 W/kg

**SAR(1 g) = 12.6 W/kg; SAR(10 g) = 5.77 W/kg**

Maximum value of SAR (measured) = 19.4 W/kg

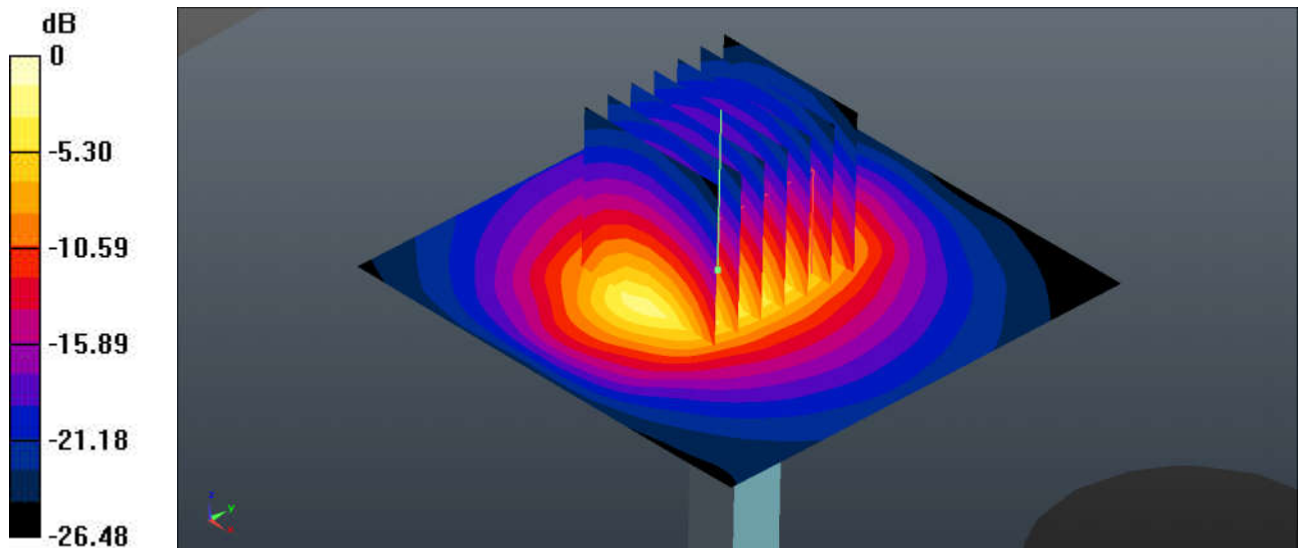

0 dB = 19.9 W/kg = 12.99 dBW/kg

**System Check\_Head\_2600MHz**

**DUT: D2600V2 - SN:1061**

Communication System: UID 0, CW (0); Frequency: 2600 MHz;Duty Cycle: 1:1  
 Medium: HSL\_2600 Medium parameters used:  $f = 2600$  MHz;  $\sigma = 2.039$  S/m;  $\epsilon_r = 39.681$ ;  $\rho = 1000$  kg/m<sup>3</sup>  
 Ambient Temperature : 23.3 °C; Liquid Temperature : 22.9 °C

DASY5 Configuration:

- Probe: EX3DV4 - SN3935; ConvF(7.38, 7.38, 7.38); Calibrated: 2018.11.26
- Sensor-Surface: 1.4mm (Mechanical Surface Detection)
- Electronics: DAE4 Sn690; Calibrated: 2019.1.23
- Phantom: SAM1; Type: SAM; Serial: TP-1753
- Measurement SW: DASY52, Version 52.10 (1); SEMCAD X Version 14.6.11 (7439)

**Pin=250mW/Area Scan (71x71x1):** Interpolated grid: dx=1.200 mm, dy=1.200 mm  
 Maximum value of SAR (interpolated) = 23.3 W/kg

**Pin=250mW/Zoom Scan (7x7x7)/Cube 0:** Measurement grid: dx=5mm, dy=5mm, dz=5mm  
 Reference Value = 83.43 V/m; Power Drift = 0.07 dB  
 Peak SAR (extrapolated) = 31.1 W/kg  
**SAR(1 g) = 14.1 W/kg; SAR(10 g) = 6.22 W/kg**  
 Maximum value of SAR (measured) = 22.3 W/kg

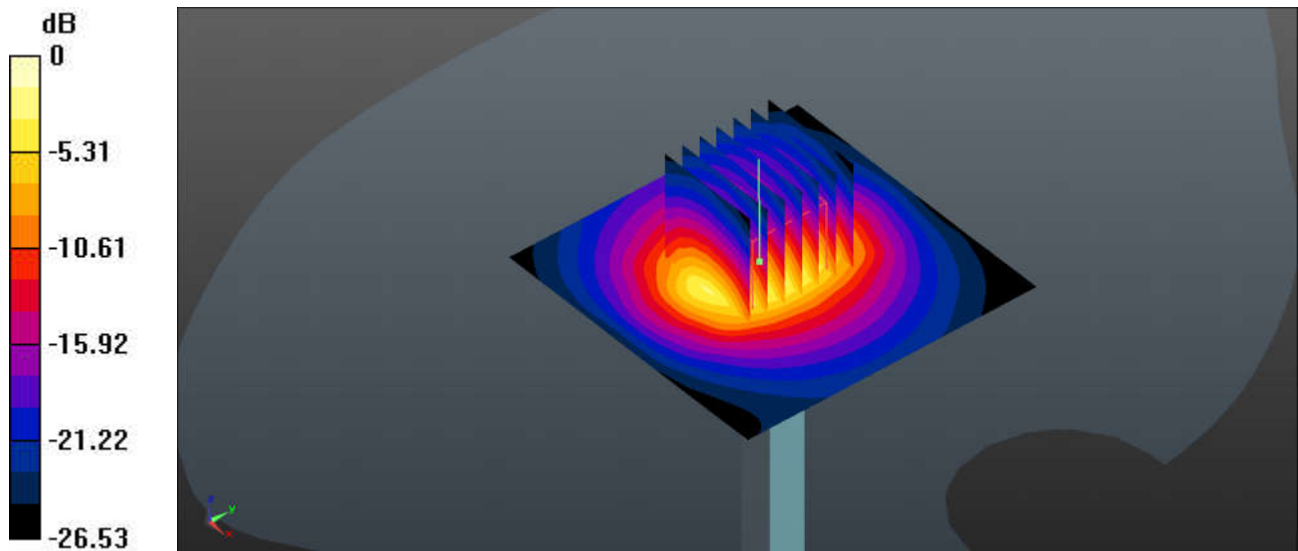

0 dB = 23.3 W/kg = 13.67 dBW/kg



**Appendix B. Plots of High SAR Measurement**

The plots are shown as follows.

**01\_GSM850\_GPRS 2 Tx slots\_Right Cheek\_0mm\_Ch251**

Communication System: UID 0, GSM850-2UP (0); Frequency: 848.8 MHz; Duty Cycle: 1:4.15  
 Medium: HSL\_850 Medium parameters used:  $f = 849$  MHz;  $\sigma = 0.943$  S/m;  $\epsilon_r = 42.081$ ;  $\rho = 1000$  kg/m<sup>3</sup>  
 Ambient Temperature : 23.3 °C; Liquid Temperature : 22.7 °C

DASY5 Configuration:

- Probe: EX3DV4 - SN3935; ConvF(10.48, 10.48, 10.48); Calibrated: 2018.11.26
- Sensor-Surface: 1.4mm (Mechanical Surface Detection)
- Electronics: DAE4 Sn690; Calibrated: 2019.1.23
- Phantom: SAM2; Type: SAM; Serial: TP-1754
- Measurement SW: DASY52, Version 52.10 (1); SEMCAD X Version 14.6.11 (7439)

**Ch251/Area Scan (81x81x1):** Interpolated grid: dx=1.500 mm, dy=1.500 mm

Maximum value of SAR (interpolated) = 0.530 W/kg

**Ch251/Zoom Scan (7x6x7)/Cube 0:** Measurement grid: dx=8mm, dy=8mm, dz=5mm

Reference Value = 7.185 V/m; Power Drift = -0.07 dB

Peak SAR (extrapolated) = 0.572 W/kg

**SAR(1 g) = 0.442 W/kg; SAR(10 g) = 0.345 W/kg**

Maximum value of SAR (measured) = 0.521 W/kg

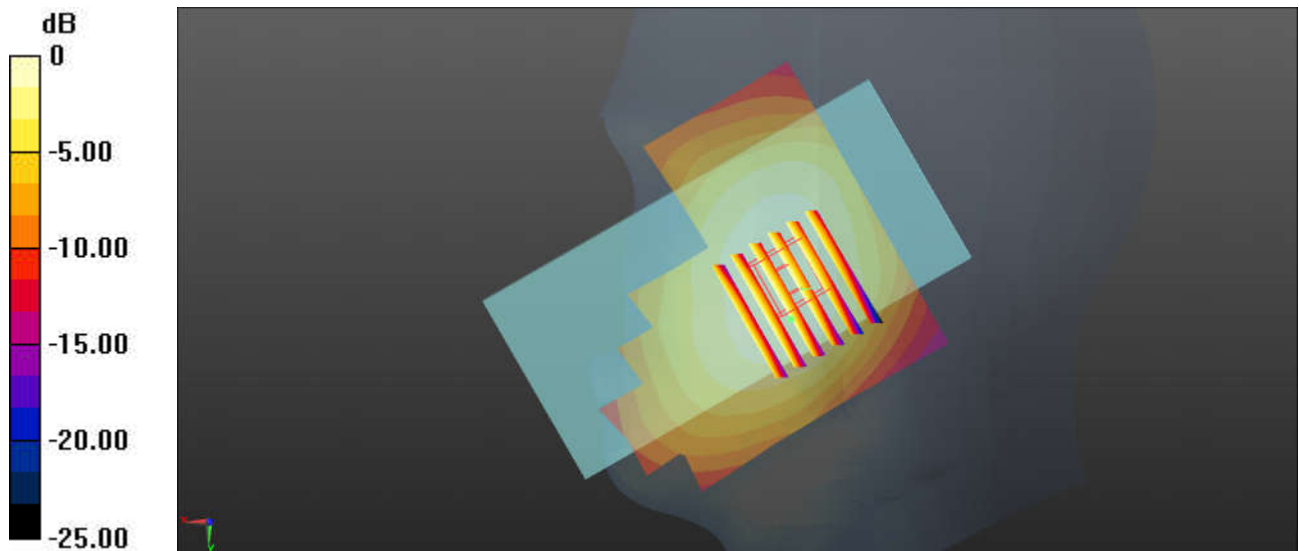

0 dB = 0.530 W/kg = -2.76 dBW/kg

**02\_GSM1900\_GPRS 2 Tx slots\_Right Cheek\_0mm\_Ch661**

Communication System: UID 0, PCS-2UP (0); Frequency: 1880 MHz; Duty Cycle: 1:4.15  
 Medium: HSL\_1900 Medium parameters used:  $f = 1880$  MHz;  $\sigma = 1.326$  S/m;  $\epsilon_r = 41.529$ ;  $\rho = 1000$  kg/m<sup>3</sup>  
 Ambient Temperature : 23.3 °C; Liquid Temperature : 22.7 °C

DASY5 Configuration:

- Probe: EX3DV4 - SN3935; ConvF(8.5, 8.5, 8.5); Calibrated: 2018.11.26
- Sensor-Surface: 1.4mm (Mechanical Surface Detection)
- Electronics: DAE4 Sn690; Calibrated: 2019.1.23
- Phantom: SAM2; Type: SAM; Serial: TP-1754
- Measurement SW: DASY52, Version 52.10 (1); SEMCAD X Version 14.6.11 (7439)

**Ch661/Area Scan (71x71x1):** Interpolated grid: dx=1.500 mm, dy=1.500 mm

Maximum value of SAR (interpolated) = 0.150 W/kg

**Ch661/Zoom Scan (5x5x7)/Cube 0:** Measurement grid: dx=8mm, dy=8mm, dz=5mm

Reference Value = 1.931 V/m; Power Drift = 0.09 dB

Peak SAR (extrapolated) = 0.193 W/kg

**SAR(1 g) = 0.129 W/kg; SAR(10 g) = 0.084 W/kg**

Maximum value of SAR (measured) = 0.148 W/kg

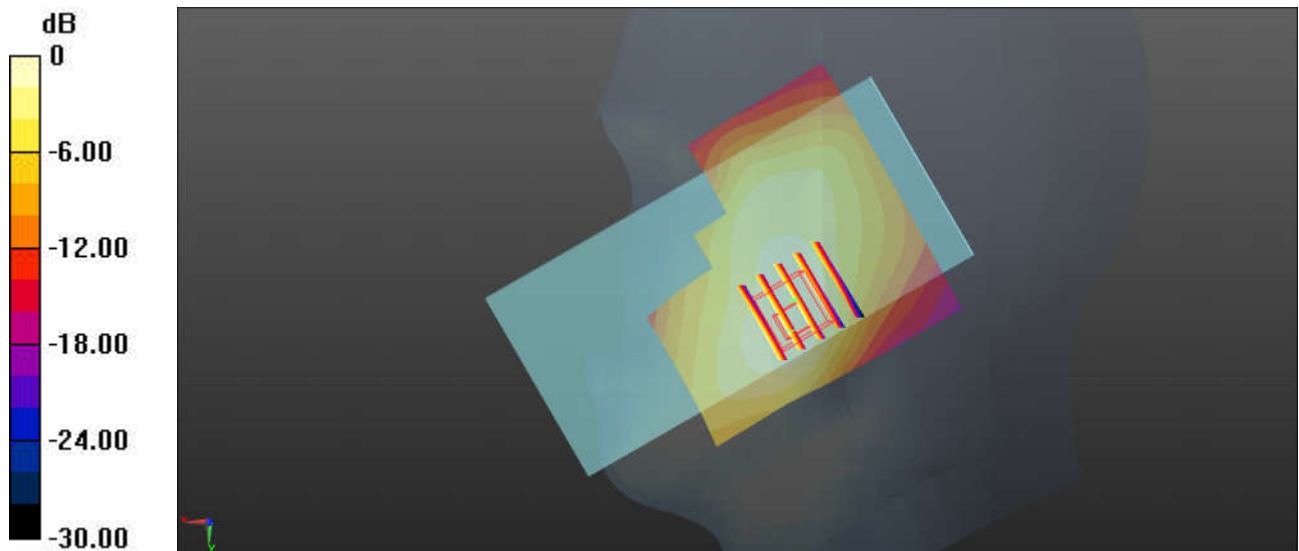

0 dB = 0.150 W/kg = -8.24 dBW/kg



**03\_WCDMA II\_RMC 12.2Kbps\_Right Cheek\_0mm\_Ch9400**

Communication System: UID 0, WCDMA (0); Frequency: 1880 MHz; Duty Cycle: 1:1  
 Medium: HSL\_1900 Medium parameters used:  $f = 1880$  MHz;  $\sigma = 1.326$  S/m;  $\epsilon_r = 41.529$ ;  $\rho = 1000$  kg/m<sup>3</sup>  
 Ambient Temperature : 23.3 °C ; Liquid Temperature : 22.7 °C

DASY5 Configuration:

- Probe: EX3DV4 - SN3935; ConvF(8.5, 8.5, 8.5); Calibrated: 2018.11.26
- Sensor-Surface: 1.4mm (Mechanical Surface Detection)
- Electronics: DAE4 Sn690; Calibrated: 2019.1.23
- Phantom: SAM2; Type: SAM; Serial: TP-1754
- Measurement SW: DASY52, Version 52.10 (1); SEMCAD X Version 14.6.11 (7439)

**Ch9400/Area Scan (71x71x1):** Interpolated grid: dx=1.500 mm, dy=1.500 mm

Maximum value of SAR (interpolated) = 0.255 W/kg

**Ch9400/Zoom Scan (5x5x7)/Cube 0:** Measurement grid: dx=8mm, dy=8mm, dz=5mm

Reference Value = 2.648 V/m; Power Drift = 0.02 dB

Peak SAR (extrapolated) = 0.313 W/kg

**SAR(1 g) = 0.219 W/kg; SAR(10 g) = 0.142 W/kg**

Maximum value of SAR (measured) = 0.246 W/kg

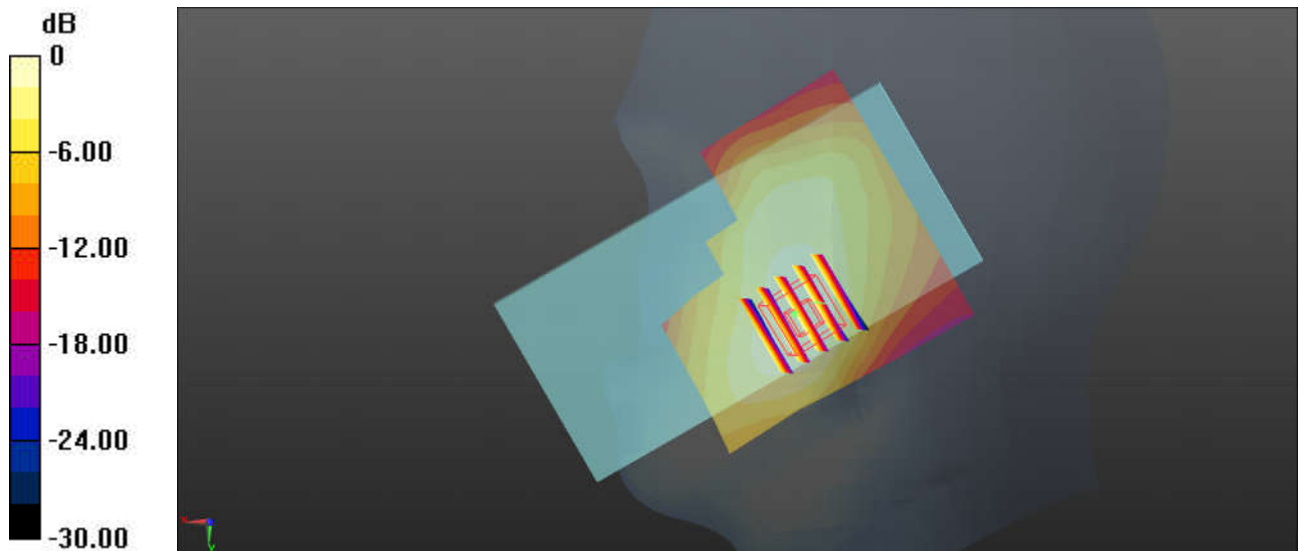

0 dB = 0.255 W/kg = -5.93 dBW/kg

**04\_WCDMA IV\_RMC 12.2Kbps\_Right Cheek\_0mm\_Ch1413**

Communication System: UID 0, WCDMA (0); Frequency: 1732.6 MHz; Duty Cycle: 1:1  
 Medium: HSL\_1750 Medium parameters used:  $f = 1733$  MHz;  $\sigma = 1.363$  S/m;  $\epsilon_r = 39.779$ ;  $\rho = 1000$  kg/m<sup>3</sup>  
 Ambient Temperature : 23.2 °C; Liquid Temperature : 22.9 °C

DASY5 Configuration:

- Probe: EX3DV4 - SN3935; ConvF(8.91, 8.91, 8.91); Calibrated: 2018.11.26
- Sensor-Surface: 1.4mm (Mechanical Surface Detection)
- Electronics: DAE4 Sn690; Calibrated: 2019.1.23
- Phantom: SAM2; Type: SAM; Serial: TP-1754
- Measurement SW: DASY52, Version 52.10 (1); SEMCAD X Version 14.6.11 (7439)

**Ch1413/Area Scan (71x71x1):** Interpolated grid: dx=1.500 mm, dy=1.500 mm

Maximum value of SAR (interpolated) = 0.144 W/kg

**Ch1413/Zoom Scan (5x5x7)/Cube 0:** Measurement grid: dx=8mm, dy=8mm, dz=5mm

Reference Value = 3.331 V/m; Power Drift = 0.09 dB

Peak SAR (extrapolated) = 0.184 W/kg

**SAR(1 g) = 0.127 W/kg; SAR(10 g) = 0.085 W/kg**

Maximum value of SAR (measured) = 0.146 W/kg

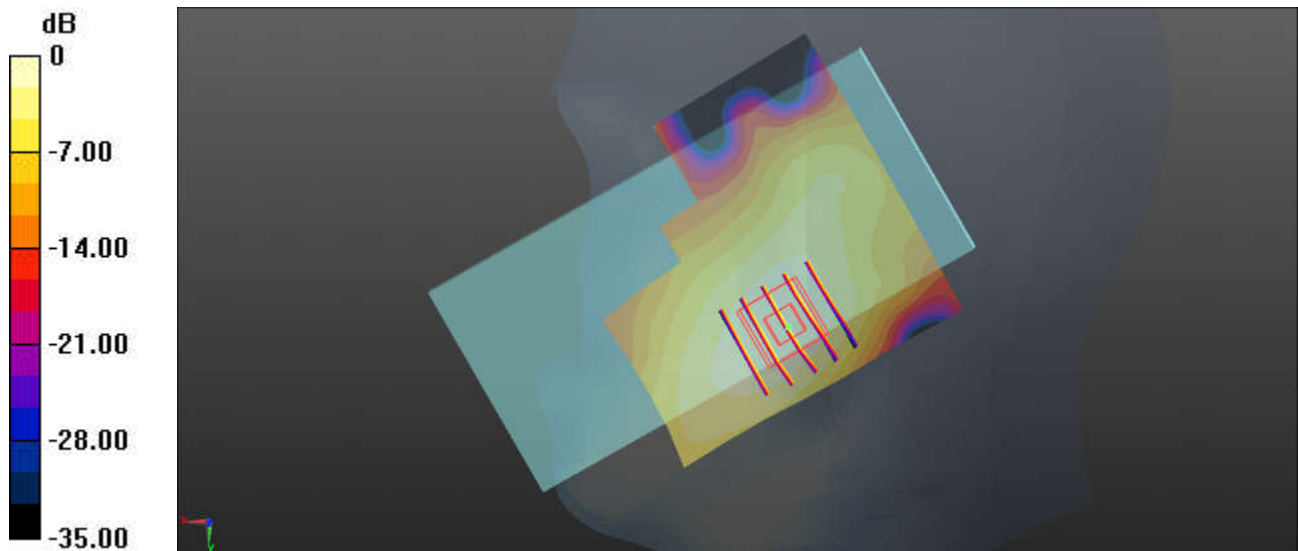

0 dB = 0.144 W/kg = -8.42 dBW/kg

**05\_WCDMA V\_RMC 12.2Kbps\_Right Cheek\_0mm\_Ch4182**

Communication System: UID 0, WCDMA (0); Frequency: 836.4 MHz; Duty Cycle: 1:1  
 Medium: HSL\_850 Medium parameters used:  $f = 836.4$  MHz;  $\sigma = 0.93$  S/m;  $\epsilon_r = 42.205$ ;  $\rho = 1000$  kg/m<sup>3</sup>  
 Ambient Temperature : 23.3 °C; Liquid Temperature : 22.7 °C

DASY5 Configuration:

- Probe: EX3DV4 - SN3935; ConvF(10.48, 10.48, 10.48); Calibrated: 2018.11.26
- Sensor-Surface: 1.4mm (Mechanical Surface Detection)
- Electronics: DAE4 Sn690; Calibrated: 2019.1.23
- Phantom: SAM2; Type: SAM; Serial: TP-1754
- Measurement SW: DASY52, Version 52.10 (1); SEMCAD X Version 14.6.11 (7439)

**Ch4182/Area Scan (71x71x1):** Interpolated grid: dx=1.500 mm, dy=1.500 mm

Maximum value of SAR (interpolated) = 0.478 W/kg

**Ch4182/Zoom Scan (6x5x7)/Cube 0:** Measurement grid: dx=8mm, dy=8mm, dz=5mm

Reference Value = 6.680 V/m; Power Drift = -0.17 dB

Peak SAR (extrapolated) = 0.508 W/kg

**SAR(1 g) = 0.403 W/kg; SAR(10 g) = 0.311 W/kg**

Maximum value of SAR (measured) = 0.468 W/kg

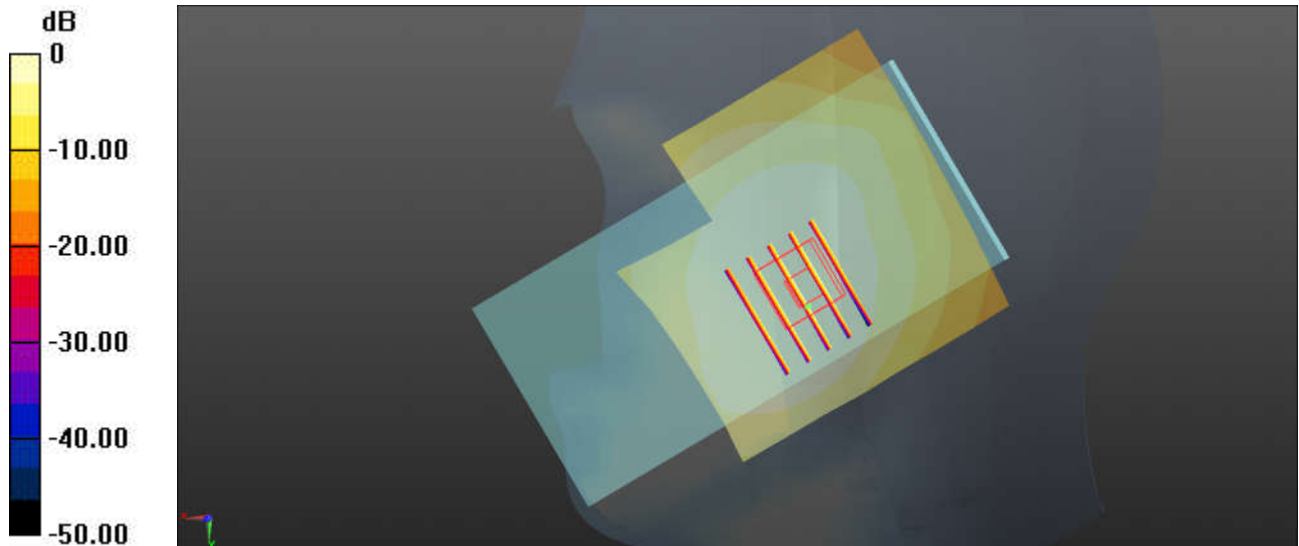

0 dB = 0.478 W/kg = -3.21 dBW/kg

**06\_LTE Band 2\_20M QPSK\_1RB\_0Offset\_Right Cheek\_0mm\_Ch18900**

Communication System: UID 0, LTE-FDD (0); Frequency: 1880 MHz; Duty Cycle: 1:1  
 Medium: HSL\_1900 Medium parameters used:  $f = 1880$  MHz;  $\sigma = 1.326$  S/m;  $\epsilon_r = 41.529$ ;  $\rho = 1000$  kg/m<sup>3</sup>  
 Ambient Temperature : 23.3 °C; Liquid Temperature : 22.7 °C

DASY5 Configuration:

- Probe: EX3DV4 - SN3935; ConvF(8.5, 8.5, 8.5); Calibrated: 2018.11.26
- Sensor-Surface: 1.4mm (Mechanical Surface Detection)
- Electronics: DAE4 Sn690; Calibrated: 2019.1.23
- Phantom: SAM2; Type: SAM; Serial: TP-1754
- Measurement SW: DASY52, Version 52.10 (1); SEMCAD X Version 14.6.11 (7439)

**Ch18900/Area Scan (71x71x1):** Interpolated grid: dx=1.500 mm, dy=1.500 mm

Maximum value of SAR (interpolated) = 0.259 W/kg

**Ch18900/Zoom Scan (5x5x7)/Cube 0:** Measurement grid: dx=8mm, dy=8mm, dz=5mm

Reference Value = 3.059 V/m; Power Drift = 0.01 dB

Peak SAR (extrapolated) = 0.321 W/kg

**SAR(1 g) = 0.221 W/kg; SAR(10 g) = 0.146 W/kg**

Maximum value of SAR (measured) = 0.254 W/kg

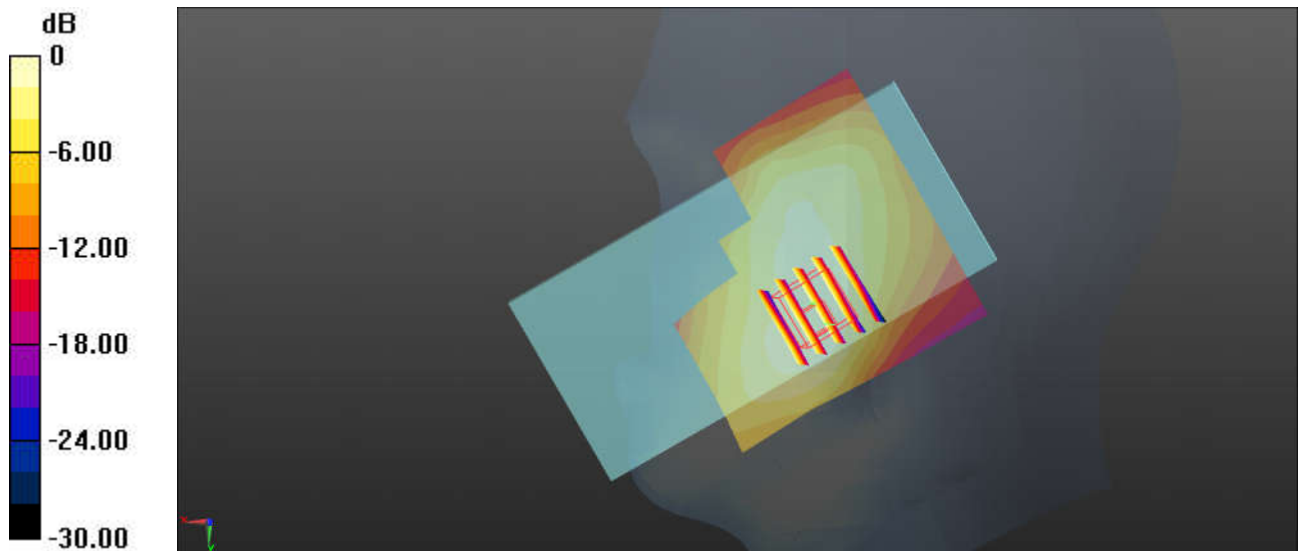

0 dB = 0.259 W/kg = -5.87 dBW/kg

**07\_LTE Band 5\_10M QPSK\_1RB\_0Offset\_Right Cheek\_0mm\_Ch20525**

Communication System: UID 0, LTE-FDD (0); Frequency: 836.5 MHz; Duty Cycle: 1:1  
 Medium: HSL\_850 Medium parameters used:  $f = 836.5$  MHz;  $\sigma = 0.931$  S/m;  $\epsilon_r = 42.204$ ;  $\rho = 1000$  kg/m<sup>3</sup>  
 Ambient Temperature : 23.3 °C; Liquid Temperature : 22.7 °C

DASY5 Configuration:

- Probe: EX3DV4 - SN3935; ConvF(10.48, 10.48, 10.48); Calibrated: 2018.11.26
- Sensor-Surface: 1.4mm (Mechanical Surface Detection)
- Electronics: DAE4 Sn690; Calibrated: 2019.1.23
- Phantom: SAM2; Type: SAM; Serial: TP-1754
- Measurement SW: DASY52, Version 52.10 (1); SEMCAD X Version 14.6.11 (7439)

**Ch20525/Area Scan (71x71x1):** Interpolated grid: dx=1.500 mm, dy=1.500 mm

Maximum value of SAR (interpolated) = 0.731 W/kg

**Ch20525/Zoom Scan (6x5x7)/Cube 0:** Measurement grid: dx=8mm, dy=8mm, dz=5mm

Reference Value = 8.519 V/m; Power Drift = -0.09 dB

Peak SAR (extrapolated) = 0.755 W/kg

**SAR(1 g) = 0.607 W/kg; SAR(10 g) = 0.474 W/kg**

Maximum value of SAR (measured) = 0.707 W/kg

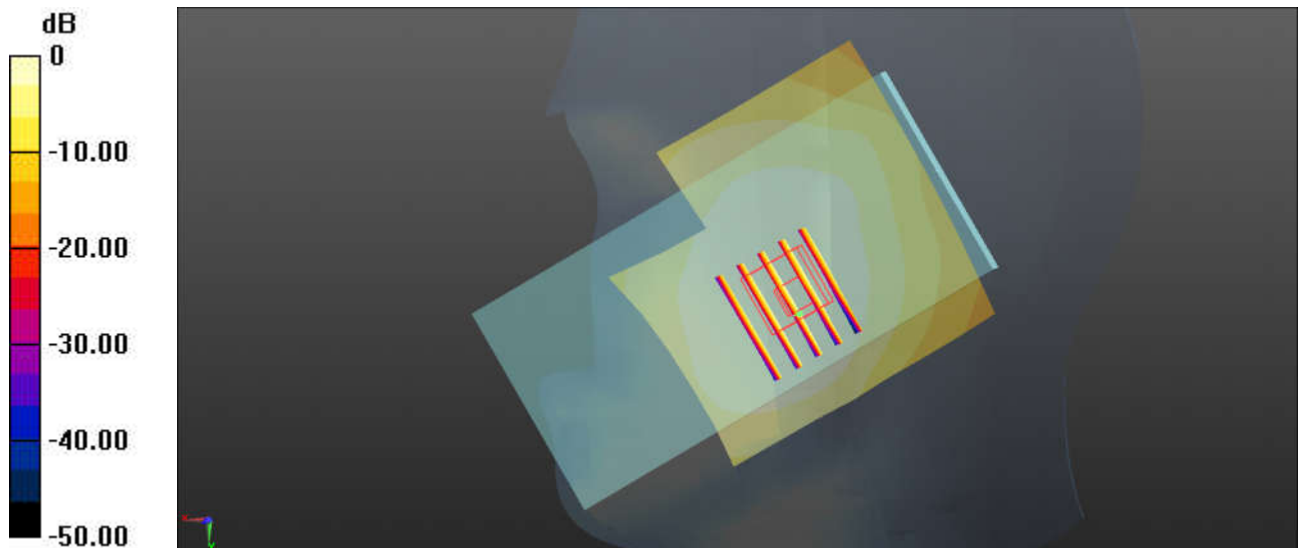

0 dB = 0.731 W/kg = -1.36 dBW/kg

**08\_LTE Band 7\_20M QPSK\_1RB\_99Offset\_Left Cheek\_0mm\_Ch20850**

Communication System: UID 0, LTE-FDD (0); Frequency: 2510 MHz; Duty Cycle: 1:1  
 Medium: HSL\_2600 Medium parameters used:  $f = 2510$  MHz;  $\sigma = 1.93$  S/m;  $\epsilon_r = 40.048$ ;  $\rho = 1000$  kg/m<sup>3</sup>  
 Ambient Temperature : 23.3 °C; Liquid Temperature : 22.9 °C

DASY5 Configuration:

- Probe: EX3DV4 - SN3935; ConvF(7.38, 7.38, 7.38); Calibrated: 2018.11.26
- Sensor-Surface: 1.4mm (Mechanical Surface Detection)
- Electronics: DAE4 Sn690; Calibrated: 2019.1.23
- Phantom: SAM1; Type: SAM; Serial: TP-1753
- Measurement SW: DASY52, Version 52.10 (1); SEMCAD X Version 14.6.11 (7439)

**Ch20850/Area Scan (91x101x1):** Interpolated grid: dx=1.200 mm, dy=1.200 mm  
 Maximum value of SAR (interpolated) = 0.216 W/kg

**Ch20850/Zoom Scan (7x8x7)/Cube 0:** Measurement grid: dx=5mm, dy=5mm, dz=5mm  
 Reference Value = 3.558 V/m; Power Drift = 0.06 dB  
 Peak SAR (extrapolated) = 0.309 W/kg  
**SAR(1 g) = 0.173 W/kg; SAR(10 g) = 0.091 W/kg**  
 Maximum value of SAR (measured) = 0.212 W/kg

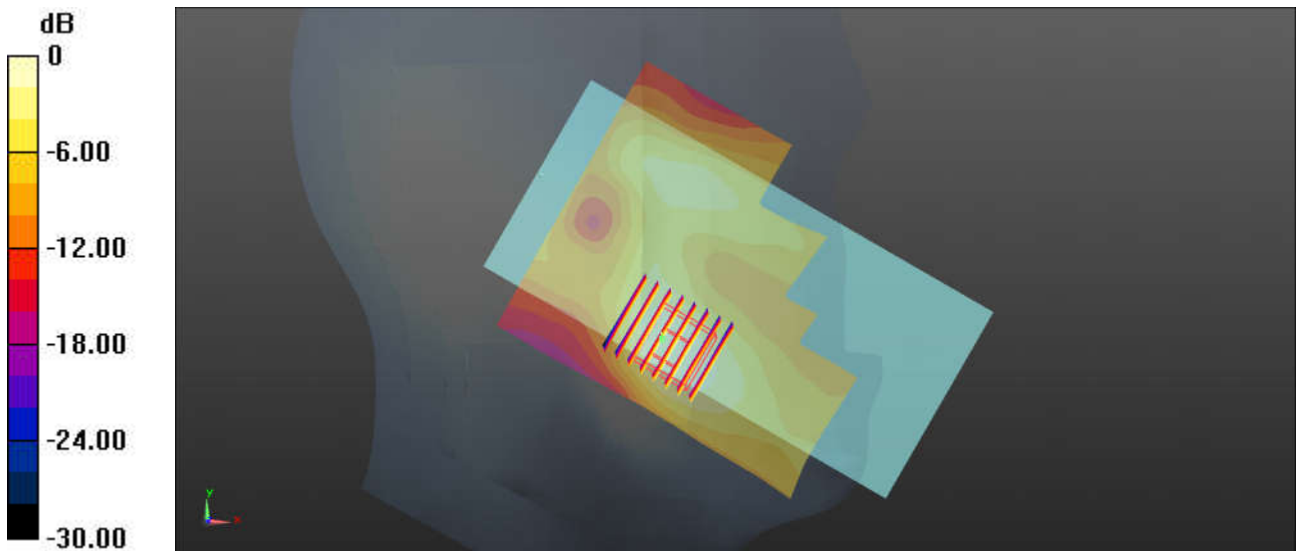

0 dB = 0.216 W/kg = -6.66 dBW/kg

**09\_LTE Band 66\_20M QPSK\_1RB\_0Offset\_Right Cheek\_0mm\_Ch132072**

Communication System: UID 0, LTE-FDD (0); Frequency: 1720 MHz; Duty Cycle: 1:1  
Medium: HSL\_1750 Medium parameters used:  $f = 1720$  MHz;  $\sigma = 1.35$  S/m;  $\epsilon_r = 39.852$ ;  $\rho = 1000$  kg/m<sup>3</sup>  
Ambient Temperature : 23.2 °C; Liquid Temperature : 22.9 °C

## DASY5 Configuration:

- Probe: EX3DV4 - SN3935; ConvF(8.91, 8.91, 8.91); Calibrated: 2018.11.26
- Sensor-Surface: 1.4mm (Mechanical Surface Detection)
- Electronics: DAE4 Sn690; Calibrated: 2019.1.23
- Phantom: SAM2; Type: SAM; Serial: TP-1754
- Measurement SW: DASY52, Version 52.10 (1); SEMCAD X Version 14.6.11 (7439)

**Ch132072/Area Scan (71x71x1):** Interpolated grid: dx=1.500 mm, dy=1.500 mm

Maximum value of SAR (interpolated) = 0.0987 W/kg

**Ch132072/Zoom Scan (5x5x7)/Cube 0:** Measurement grid: dx=8mm, dy=8mm, dz=5mm

Reference Value = 2.726 V/m; Power Drift = -0.05 dB

Peak SAR (extrapolated) = 0.125 W/kg

**SAR(1 g) = 0.086 W/kg; SAR(10 g) = 0.057 W/kg**

Maximum value of SAR (measured) = 0.0970 W/kg

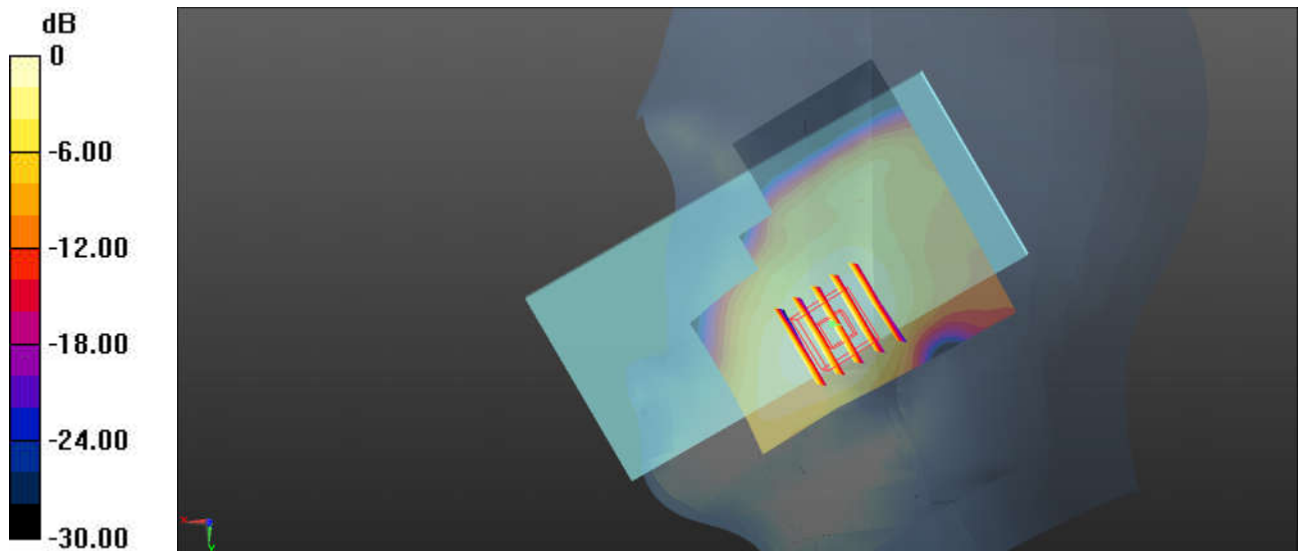

**10\_WLAN2.4GHz\_802.11b 1Mbps\_Left Cheek\_0mm\_Ch1**

Communication System: UID 0, 802.11b (0); Frequency: 2412 MHz; Duty Cycle: 1:1.014  
 Medium: HSL\_2450 Medium parameters used:  $f = 2412 \text{ MHz}$ ;  $\sigma = 1.766 \text{ S/m}$ ;  $\epsilon_r = 38.483$ ;  $\rho = 1000 \text{ kg/m}^3$   
 Ambient Temperature :  $23.2 \text{ }^\circ\text{C}$ ; Liquid Temperature :  $22.6 \text{ }^\circ\text{C}$

DASY5 Configuration:

- Probe: EX3DV4 - SN3935; ConvF(7.69, 7.69, 7.69); Calibrated: 2018.11.26
- Sensor-Surface: 1.4mm (Mechanical Surface Detection)
- Electronics: DAE4 Sn690; Calibrated: 2019.1.23
- Phantom: SAM1; Type: SAM; Serial: TP-1753
- Measurement SW: DASY52, Version 52.10 (1); SEMCAD X Version 14.6.11 (7439)

**Ch1/Area Scan (91x81x1):** Interpolated grid:  $dx=1.200 \text{ mm}$ ,  $dy=1.200 \text{ mm}$   
 Maximum value of SAR (interpolated) =  $1.32 \text{ W/kg}$

**Ch1/Zoom Scan (7x10x7)/Cube 0:** Measurement grid:  $dx=5\text{mm}$ ,  $dy=5\text{mm}$ ,  $dz=5\text{mm}$   
 Reference Value =  $15.83 \text{ V/m}$ ; Power Drift =  $-0.07 \text{ dB}$   
 Peak SAR (extrapolated) =  $1.70 \text{ W/kg}$   
**SAR(1 g) =  $0.888 \text{ W/kg}$ ; SAR(10 g) =  $0.447 \text{ W/kg}$**   
 Maximum value of SAR (measured) =  $1.40 \text{ W/kg}$

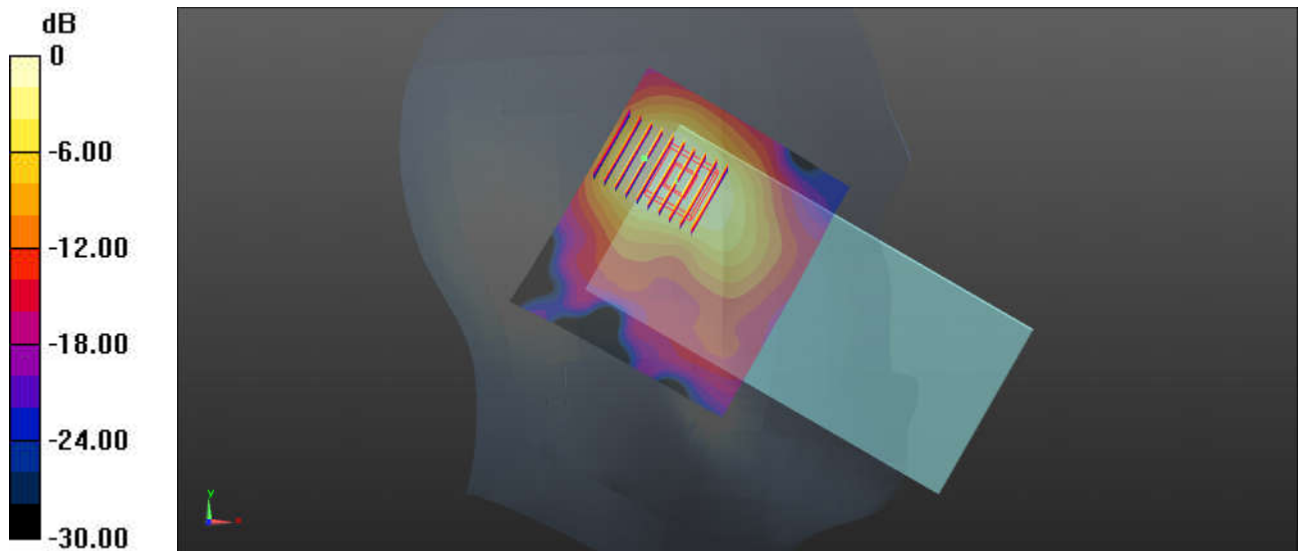

0 dB =  $1.32 \text{ W/kg} = 1.21 \text{ dBW/kg}$



## 11\_ Bluetooth\_1Mbps\_Left Cheek\_0mm\_Ch78

Communication System: UID 0, Bluetooth (0); Frequency: 2480 MHz; Duty Cycle: 1:1.293  
Medium: HSL\_2450 Medium parameters used:  $f = 2480$  MHz;  $\sigma = 1.843$  S/m;  $\epsilon_r = 38.207$ ;  $\rho = 1000$  kg/m<sup>3</sup>  
Ambient Temperature : 23.2 °C; Liquid Temperature : 22.6 °C

DASY5 Configuration:

- Probe: EX3DV4 - SN3935; ConvF(7.69, 7.69, 7.69); Calibrated: 2018.11.26
- Sensor-Surface: 1.4mm (Mechanical Surface Detection)
- Electronics: DAE4 Sn690; Calibrated: 2019.1.23
- Phantom: SAM1; Type: SAM; Serial: TP-1753
- Measurement SW: DASY52, Version 52.10 (1); SEMCAD X Version 14.6.11 (7439)

**Ch78/Area Scan (91x91x1):** Interpolated grid: dx=1.200 mm, dy=1.200 mm

Maximum value of SAR (interpolated) = 0.0531 W/kg

**Ch78/Zoom Scan (7x8x7)/Cube 0:** Measurement grid: dx=5mm, dy=5mm, dz=5mm

Reference Value = 2.612 V/m; Power Drift = -0.02 dB

Peak SAR (extrapolated) = 0.0720 W/kg

**SAR(1 g) = 0.033 W/kg; SAR(10 g) = 0.017 W/kg**

Maximum value of SAR (measured) = 0.0551 W/kg

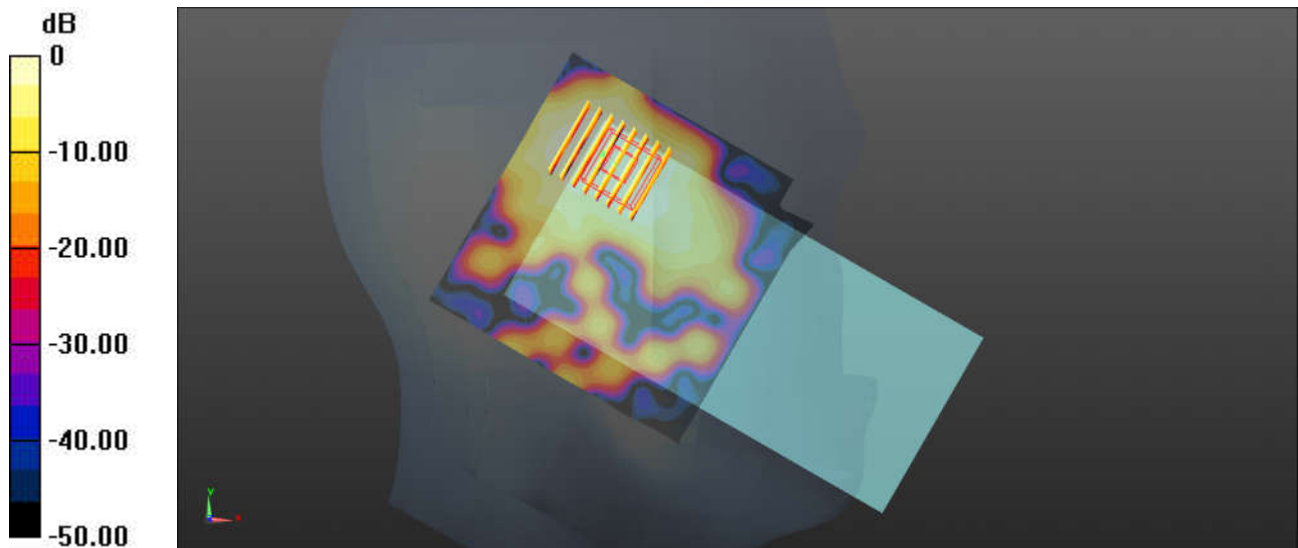

0 dB = 0.0531 W/kg = -12.75 dBW/kg

**12\_GSM850\_GPRS 2 Tx slots\_Back\_5mm\_Sensor on\_Ch251**

Communication System: UID 0, GSM850-2UP (0); Frequency: 848.8 MHz; Duty Cycle: 1:4.15  
 Medium: HSL\_850 Medium parameters used:  $f = 849 \text{ MHz}$ ;  $\sigma = 0.943 \text{ S/m}$ ;  $\epsilon_r = 42.081$ ;  $\rho = 1000 \text{ kg/m}^3$   
 Ambient Temperature :  $23.3 \text{ }^\circ\text{C}$ ; Liquid Temperature :  $22.7 \text{ }^\circ\text{C}$

DASY5 Configuration:

- Probe: EX3DV4 - SN3935; ConvF(10.48, 10.48, 10.48); Calibrated: 2018.11.26
- Sensor-Surface: 1.4mm (Mechanical Surface Detection)
- Electronics: DAE4 Sn690; Calibrated: 2019.1.23
- Phantom: SAM2; Type: SAM; Serial: TP-1754
- Measurement SW: DASY52, Version 52.10 (1); SEMCAD X Version 14.6.11 (7439)

**Ch251/Area Scan (81x71x1):** Interpolated grid:  $dx=1.500 \text{ mm}$ ,  $dy=1.500 \text{ mm}$   
 Maximum value of SAR (interpolated) =  $1.49 \text{ W/kg}$

**Ch251/Zoom Scan (6x6x7)/Cube 0:** Measurement grid:  $dx=8\text{mm}$ ,  $dy=8\text{mm}$ ,  $dz=5\text{mm}$   
 Reference Value =  $25.45 \text{ V/m}$ ; Power Drift =  $-0.04 \text{ dB}$   
 Peak SAR (extrapolated) =  $2.08 \text{ W/kg}$   
**SAR(1 g) =  $1.2 \text{ W/kg}$ ; SAR(10 g) =  $0.735 \text{ W/kg}$**   
 Maximum value of SAR (measured) =  $1.41 \text{ W/kg}$

**Ch251/Zoom Scan (6x6x7)/Cube 1:** Measurement grid:  $dx=8\text{mm}$ ,  $dy=8\text{mm}$ ,  $dz=5\text{mm}$   
 Reference Value =  $25.45 \text{ V/m}$ ; Power Drift =  $-0.04 \text{ dB}$   
 Peak SAR (extrapolated) =  $2.12 \text{ W/kg}$   
**SAR(1 g) =  $1.01 \text{ W/kg}$ ; SAR(10 g) =  $0.591 \text{ W/kg}$**   
 Maximum value of SAR (measured) =  $1.37 \text{ W/kg}$

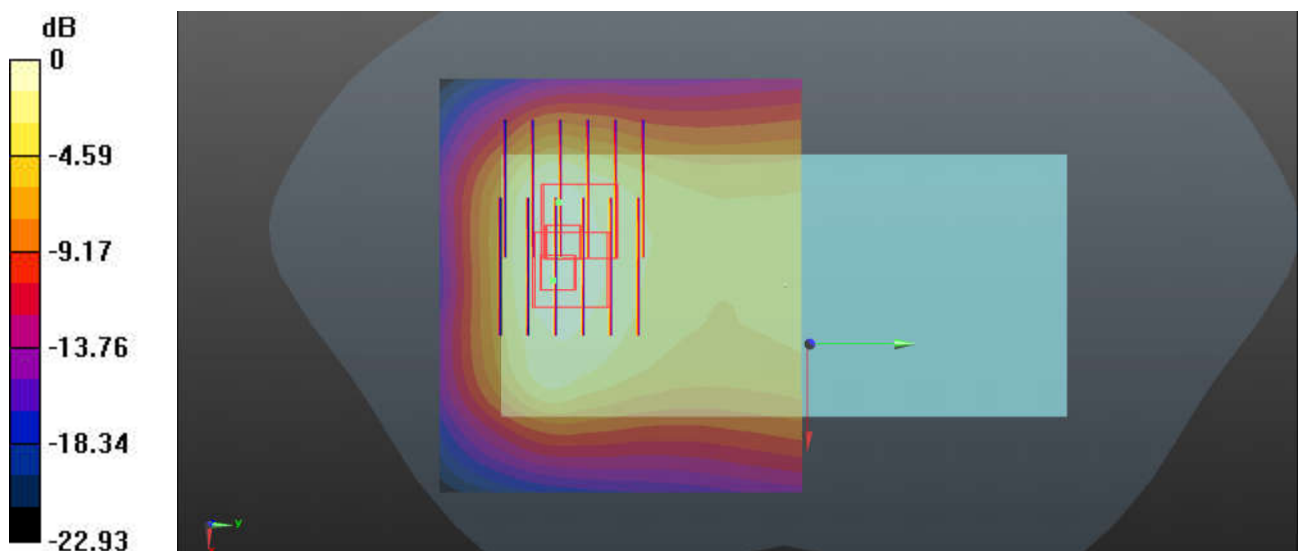

0 dB =  $1.49 \text{ W/kg} = 1.73 \text{ dBW/kg}$