

## System Check\_Head\_835MHz

**DUT: D835V2-4d167**

Communication System: CW; Frequency: 835 MHz; Duty Cycle: 1:1

Medium: HSL\_850\_190806 Medium parameters used:  $f = 835 \text{ MHz}$ ;  $\sigma = 0.886 \text{ S/m}$ ;  $\epsilon_r = 42.639$ ;  $\rho = 1000 \text{ kg/m}^3$

Ambient Temperature :  $23.3 \text{ }^\circ\text{C}$ ; Liquid Temperature :  $22.3 \text{ }^\circ\text{C}$

### DASY5 Configuration

- Probe: EX3DV4 - SN3642; ConvF(9.05, 9.05, 9.05) @ 835 MHz; Calibrated: 2019/4/29
- Sensor-Surface: 1.4mm (Mechanical Surface Detection)
- Electronics: DAE3 Sn360; Calibrated: 2018/10/29
- Phantom: Twin-SAM V5.0 (30deg probe tilt); Type: QD 000 P40 CD; Serial: 1885
- Measurement SW: DASY52, Version 52.10 (2); SEMCAD X Version 14.6.12 (7450)

**Pin=250mW/Area Scan (61x61x1):** Interpolated grid:  $dx=1.500 \text{ mm}$ ,  $dy=1.500 \text{ mm}$

Maximum value of SAR (interpolated) =  $3.23 \text{ W/kg}$

**Pin=250mW/Zoom Scan (5x5x7)/Cube 0:** Measurement grid:  $dx=8\text{mm}$ ,  $dy=8\text{mm}$ ,  $dz=5\text{mm}$

Reference Value =  $63.62 \text{ V/m}$ ; Power Drift =  $-0.17 \text{ dB}$

Peak SAR (extrapolated) =  $3.59 \text{ W/kg}$

**SAR(1 g) =  $2.37 \text{ W/kg}$ ; SAR(10 g) =  $1.55 \text{ W/kg}$**

Maximum value of SAR (measured) =  $3.20 \text{ W/kg}$

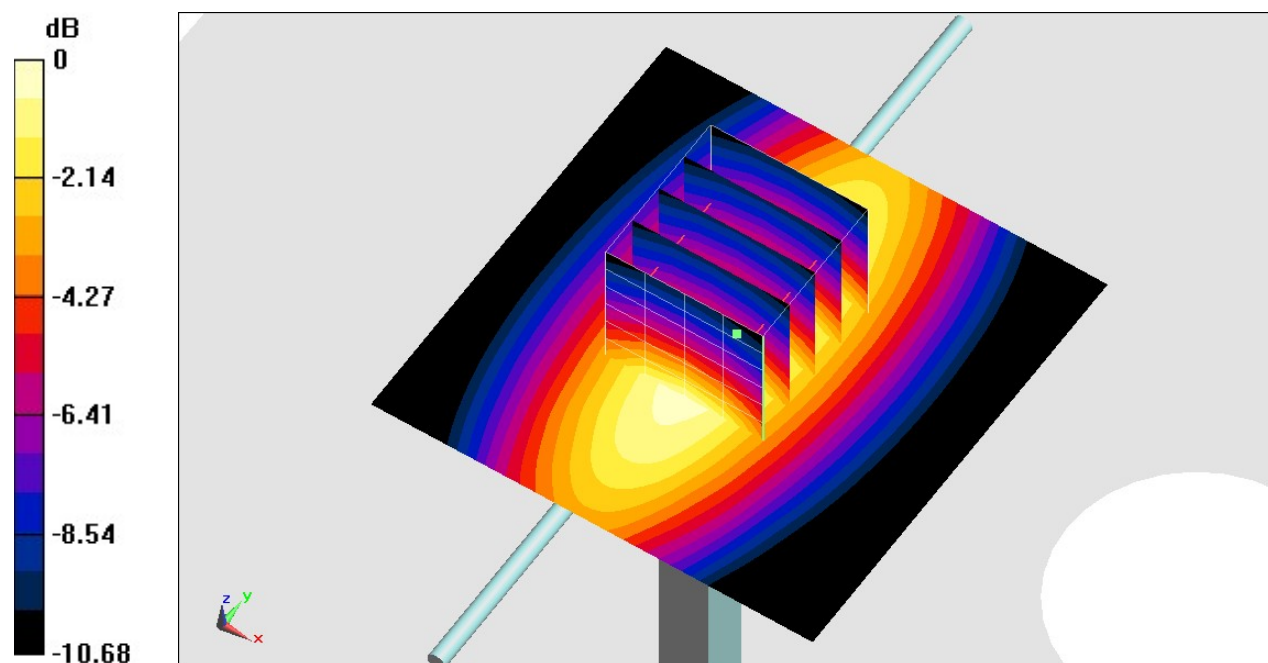

0 dB =  $3.20 \text{ W/kg} = 5.05 \text{ dBW/kg}$

## System Check\_Head\_835MHz

**DUT: D835V2-4d167**

Communication System: CW; Frequency: 835 MHz; Duty Cycle: 1:1

Medium: HSL\_850\_190808 Medium parameters used:  $f = 835 \text{ MHz}$ ;  $\sigma = 0.884 \text{ S/m}$ ;  $\epsilon_r = 42.539$ ;  $\rho = 1000 \text{ kg/m}^3$

Ambient Temperature :  $23.5 \text{ }^\circ\text{C}$ ; Liquid Temperature :  $22.5 \text{ }^\circ\text{C}$

### DASY5 Configuration

- Probe: ES3DV3 - SN3169; ConvF(6.42, 6.42, 6.42) @ 835 MHz; Calibrated: 2019/5/24
- Sensor-Surface: 3mm (Mechanical Surface Detection)
- Electronics: DAE4 Sn1326; Calibrated: 2018/9/18
- Phantom: Twin-SAM V5.0 (30deg probe tilt); Type: QD 000 P40 CD; Serial: 1885
- Measurement SW: DASY52, Version 52.10 (2); SEMCAD X Version 14.6.12 (7450)

**Pin=250mW/Area Scan (61x61x1):** Interpolated grid:  $dx=1.500 \text{ mm}$ ,  $dy=1.500 \text{ mm}$   
Maximum value of SAR (interpolated) =  $2.46 \text{ W/kg}$

**Pin=250mW/Zoom Scan (5x5x7)/Cube 0:** Measurement grid:  $dx=8\text{mm}$ ,  $dy=8\text{mm}$ ,  $dz=5\text{mm}$   
Reference Value =  $56.01 \text{ V/m}$ ; Power Drift =  $0.03 \text{ dB}$   
Peak SAR (extrapolated) =  $3.33 \text{ W/kg}$   
**SAR(1 g) = 2.26 W/kg; SAR(10 g) = 1.49 W/kg**  
Maximum value of SAR (measured) =  $2.65 \text{ W/kg}$

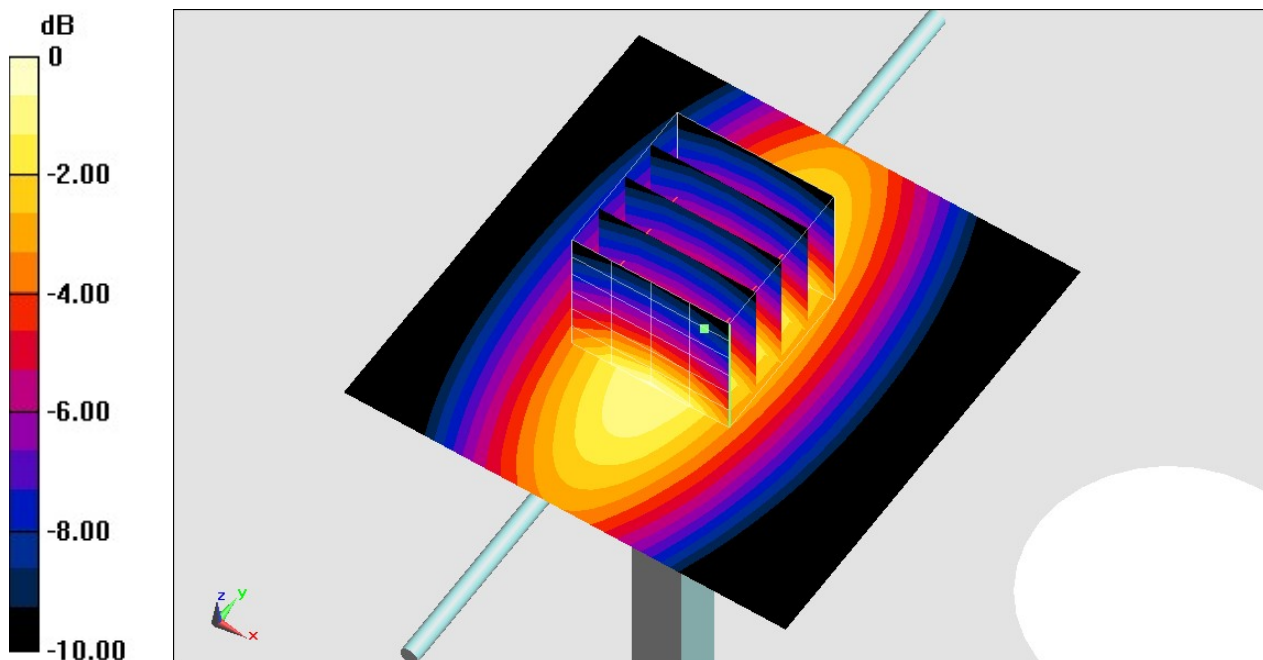

0 dB =  $2.65 \text{ W/kg} = 4.23 \text{ dBW/kg}$

## System Check\_Head\_835MHz

**DUT: D835V2-4d167**

Communication System: CW; Frequency: 835 MHz; Duty Cycle: 1:1

Medium: HSL\_850\_190816 Medium parameters used:  $f = 835$  MHz;  $\sigma = 0.888$  S/m;  $\epsilon_r = 42.159$ ;  $\rho = 1000$  kg/m<sup>3</sup>

Ambient Temperature : 23.3 °C ; Liquid Temperature : 22.3 °C

### DASY5 Configuration

- Probe: EX3DV4 - SN7346; ConvF(9.81, 9.81, 9.81) @ 835 MHz; Calibrated: 2019/4/25
- Sensor-Surface: 1.4mm (Mechanical Surface Detection)
- Electronics: DAE4 Sn1326; Calibrated: 2018/9/18
- Phantom: Twin-SAM V5.0 (30deg probe tilt); Type: QD 000 P40 CD; Serial: 1885
- Measurement SW: DASY52, Version 52.10 (2); SEMCAD X Version 14.6.12 (7450)

**Pin=250mW/Area Scan (61x61x1):** Interpolated grid: dx=1.500 mm, dy=1.500 mm  
Maximum value of SAR (interpolated) = 3.66 W/kg

**Pin=250mW/Zoom Scan (5x5x7)/Cube 0:** Measurement grid: dx=8mm, dy=8mm, dz=5mm  
Reference Value = 65.04 V/m; Power Drift = -0.13 dB  
Peak SAR (extrapolated) = 3.92 W/kg  
**SAR(1 g) = 2.42 W/kg; SAR(10 g) = 1.56 W/kg**  
Maximum value of SAR (measured) = 3.35 W/kg

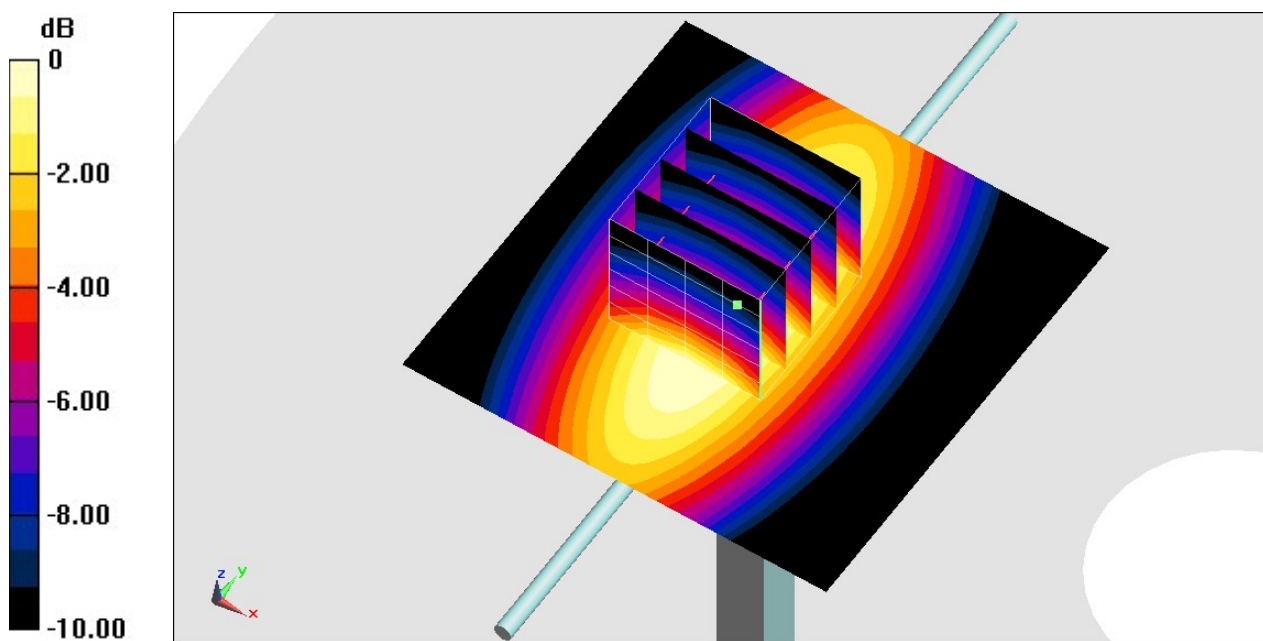

0 dB = 3.35 W/kg = 5.25 dBW/kg

## System Check\_Head\_1750MHz

### DUT: D1750V2-1112

Communication System: CW; Frequency: 1750 MHz; Duty Cycle: 1:1

Medium: HSL\_1750\_190812 Medium parameters used:  $f = 1750$  MHz;  $\sigma = 1.389$  S/m;  $\epsilon_r = 40.81$ ;  $\rho = 1000$  kg/m<sup>3</sup>

Ambient Temperature : 23.5 °C ; Liquid Temperature : 22.5 °C

DASY5 Configuration:

- Probe: EX3DV4 - SN3642; ConvF(8.18, 8.18, 8.18) @ 1750 MHz; Calibrated: 2019/4/29
- Sensor-Surface: 1.4mm (Mechanical Surface Detection)
- Electronics: DAE3 Sn360; Calibrated: 2018/10/29
- Phantom: SAM\_Left; Type: QD000P40CD; Serial: TP:1815
- Measurement SW: DASY52, Version 52.10 (2); SEMCAD X Version 14.6.12 (7470)

**Pin=250mW/Area Scan (61x61x1):** Interpolated grid: dx=1.500 mm, dy=1.500 mm  
Maximum value of SAR (interpolated) = 12.2 W/kg

**Pin=250mW/Zoom Scan (5x5x7)/Cube 0:** Measurement grid: dx=8mm, dy=8mm, dz=5mm  
Reference Value = 98.16 V/m; Power Drift = 0.12 dB  
Peak SAR (extrapolated) = 14.8 W/kg  
**SAR(1 g) = 8.45 W/kg; SAR(10 g) = 4.49 W/kg**  
Maximum value of SAR (measured) = 12.6 W/kg

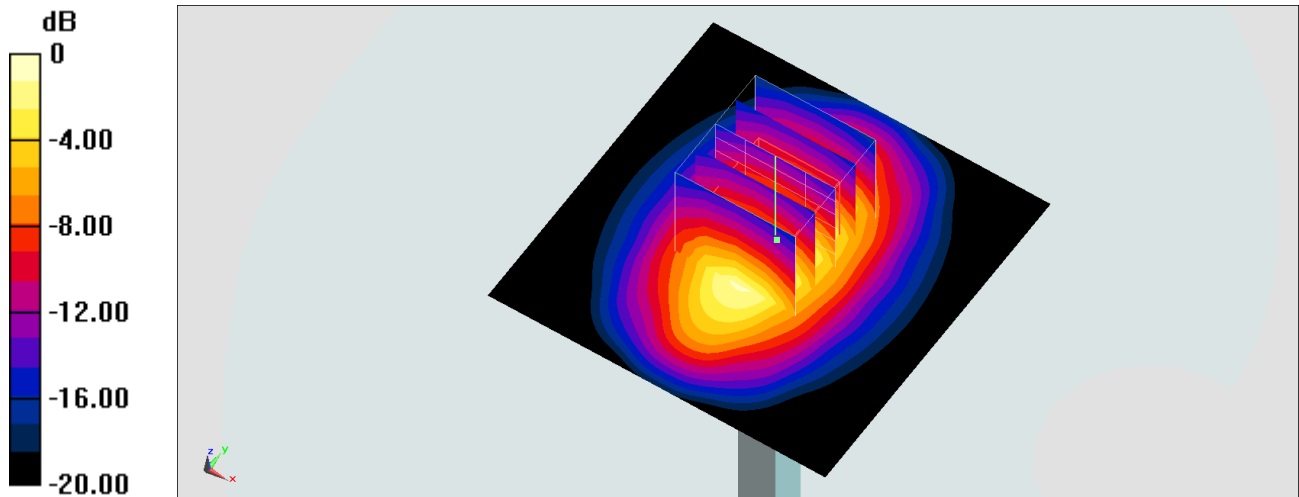

0 dB = 12.6 W/kg = 11.00 dBW/kg

## System Check\_Head\_1750MHz

### DUT: D1750V2-1112

Communication System: CW; Frequency: 1750 MHz; Duty Cycle: 1:1

Medium: HSL\_1750\_190814 Medium parameters used:  $f = 1750$  MHz;  $\sigma = 1.373$  S/m;  $\epsilon_r = 40.775$ ;  $\rho = 1000$  kg/m<sup>3</sup>

Ambient Temperature : 23.2 °C; Liquid Temperature : 22.2 °C

DASY5 Configuration:

- Probe: EX3DV4 - SN3642; ConvF(8.18, 8.18, 8.18) @ 1750 MHz; Calibrated: 2019/4/29
- Sensor-Surface: 1.4mm (Mechanical Surface Detection)
- Electronics: DAE3 Sn360; Calibrated: 2018/10/29
- Phantom: SAM\_Left; Type: QD000P40CD; Serial: TP:1815
- Measurement SW: DASY52, Version 52.10 (2); SEMCAD X Version 14.6.12 (7470)

**Pin=250mW/Area Scan (61x61x1):** Interpolated grid: dx=1.500 mm, dy=1.500 mm  
Maximum value of SAR (interpolated) = 12.1 W/kg

**Pin=250mW/Zoom Scan (5x5x7)/Cube 0:** Measurement grid: dx=8mm, dy=8mm, dz=5mm  
Reference Value = 98.16 V/m; Power Drift = 0.02 dB  
Peak SAR (extrapolated) = 14.7 W/kg  
**SAR(1 g) = 8.77 W/kg; SAR(10 g) = 4.53 W/kg**  
Maximum value of SAR (measured) = 12.5 W/kg

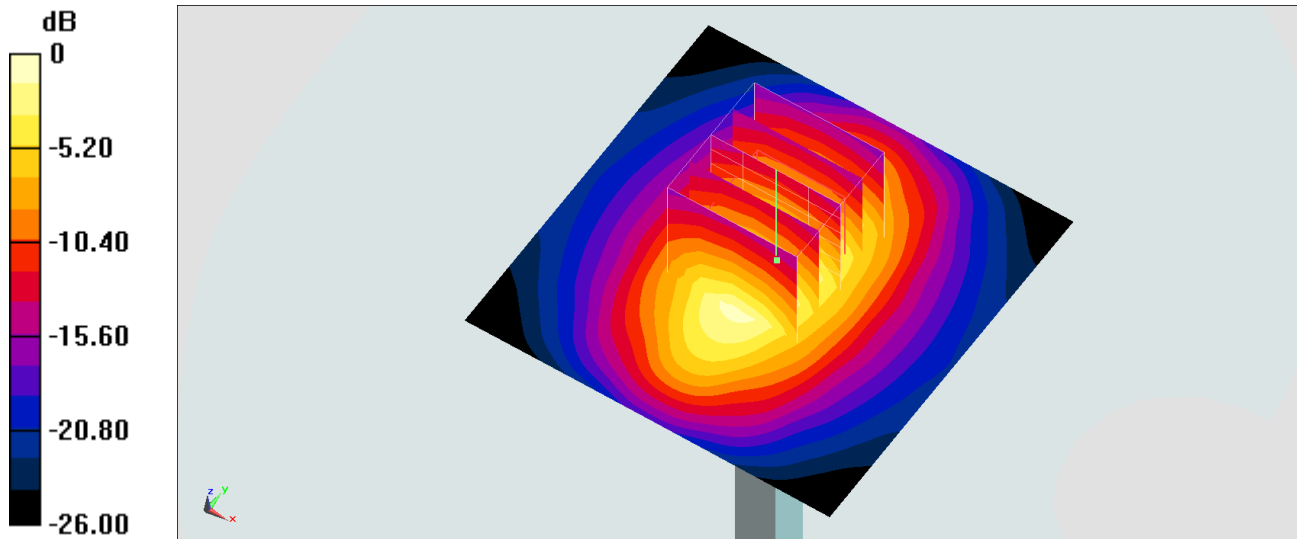

0 dB = 12.5 W/kg = 10.97 dBW/kg

## System Check\_Head\_1750MHz

### DUT: D1750V2-1112

Communication System: CW; Frequency: 1750 MHz; Duty Cycle: 1:1

Medium: HSL\_1750\_190815 Medium parameters used:  $f = 1750$  MHz;  $\sigma = 1.404$  S/m;  $\epsilon_r = 40.7$ ;  $\rho = 1000$  kg/m<sup>3</sup>

Ambient Temperature : 23.6 °C ; Liquid Temperature : 22.6 °C

DASY5 Configuration:

- Probe: EX3DV4 - SN3642; ConvF(8.18, 8.18, 8.18) @ 1750 MHz; Calibrated: 2019/4/29
- Sensor-Surface: 1.4mm (Mechanical Surface Detection)
- Electronics: DAE3 Sn360; Calibrated: 2018/10/29
- Phantom: SAM\_Left; Type: QD000P40CD; Serial: TP:1815
- Measurement SW: DASY52, Version 52.10 (2); SEMCAD X Version 14.6.12 (7470)

**Pin=250mW/Area Scan (61x61x1):** Interpolated grid: dx=1.500 mm, dy=1.500 mm  
Maximum value of SAR (interpolated) = 12.4 W/kg

**Pin=250mW/Zoom Scan (5x5x7)/Cube 0:** Measurement grid: dx=8mm, dy=8mm, dz=5mm  
Reference Value = 98.16 V/m; Power Drift = 0.05 dB  
Peak SAR (extrapolated) = 15.0 W/kg  
**SAR(1 g) = 8.54 W/kg; SAR(10 g) = 4.54 W/kg**  
Maximum value of SAR (measured) = 12.8 W/kg

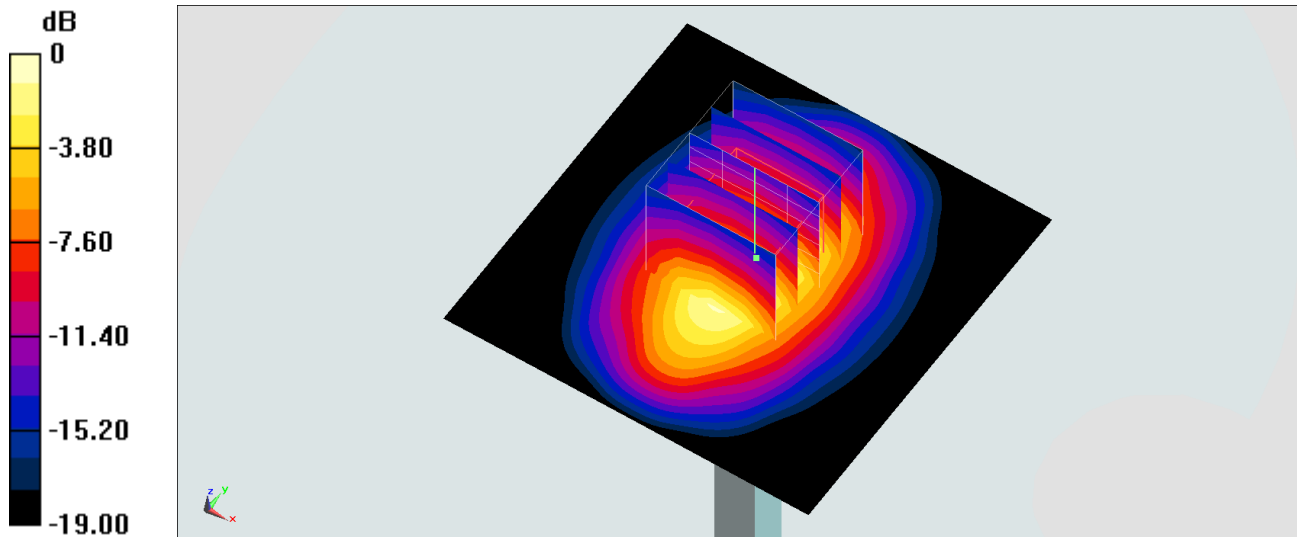

0 dB = 12.8 W/kg = 11.07 dBW/kg

## System Check\_Head\_1900MHz

### DUT: D1900V2-5d041

Communication System: CW; Frequency: 1900 MHz; Duty Cycle: 1:1

Medium: HSL\_1900\_190812 Medium parameters used:  $f = 1900$  MHz;  $\sigma = 1.415$  S/m;  $\epsilon_r = 38.515$ ;  $\rho = 1000$  kg/m<sup>3</sup>

Ambient Temperature : 23.5 °C; Liquid Temperature : 22.5 °C

DASY5 Configuration:

- Probe: EX3DV4 - SN3642; ConvF(7.91, 7.91, 7.91) @ 1900 MHz; Calibrated: 2019/4/29
- Sensor-Surface: 1.4mm (Mechanical Surface Detection)
- Electronics: DAE3 Sn360; Calibrated: 2018/10/29
- Phantom: SAM\_Left; Type: QD000P40CD; Serial: TP:1815
- Measurement SW: DASY52, Version 52.10 (2); SEMCAD X Version 14.6.12 (7470)

**Pin=250mW/Area Scan (61x61x1):** Interpolated grid: dx=1.500 mm, dy=1.500 mm  
Maximum value of SAR (interpolated) = 15.2 W/kg

**Pin=250mW/Zoom Scan (5x5x7)/Cube 0:** Measurement grid: dx=8mm, dy=8mm, dz=5mm  
Reference Value = 108.6 V/m; Power Drift = -0.07 dB  
Peak SAR (extrapolated) = 17.9 W/kg  
**SAR(1 g) = 9.6 W/kg; SAR(10 g) = 4.92 W/kg**  
Maximum value of SAR (measured) = 15.0 W/kg

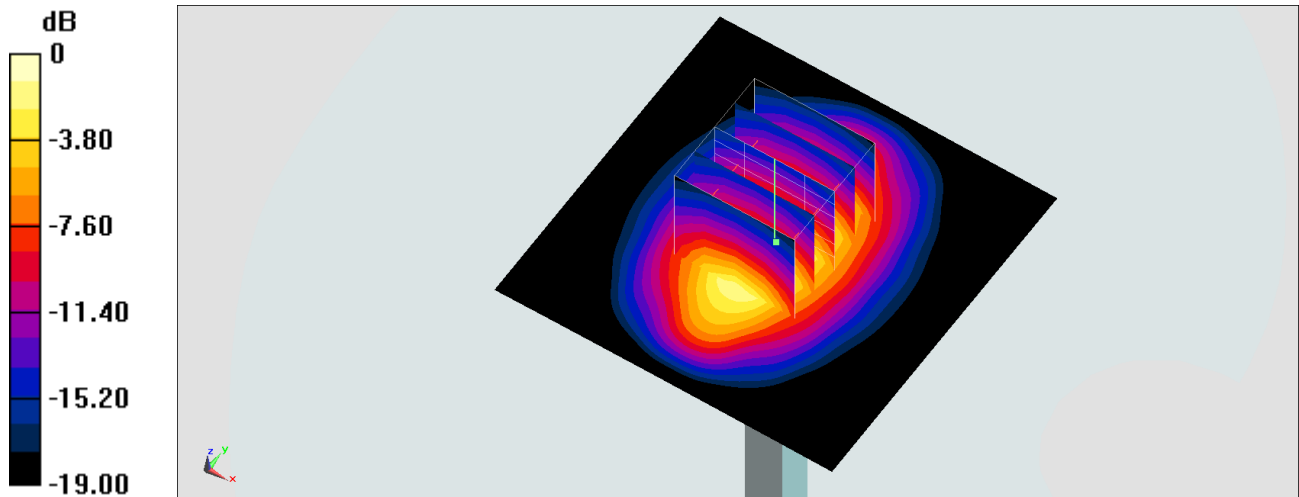

0 dB = 15.0 W/kg = 11.76 dBW/kg

## System Check\_Head\_1900MHz

### DUT: D1900V2-5d041

Communication System: CW; Frequency: 1900 MHz; Duty Cycle: 1:1

Medium: HSL\_1900\_190813 Medium parameters used:  $f = 1900$  MHz;  $\sigma = 1.448$  S/m;  $\epsilon_r = 38.266$ ;  $\rho = 1000$  kg/m<sup>3</sup>

Ambient Temperature : 23.2 °C ; Liquid Temperature : 22.2 °C

DASY5 Configuration:

- Probe: EX3DV4 - SN3642; ConvF(7.91, 7.91, 7.91) @ 1900 MHz; Calibrated: 2019/4/29
- Sensor-Surface: 1.4mm (Mechanical Surface Detection)
- Electronics: DAE3 Sn360; Calibrated: 2018/10/29
- Phantom: SAM\_Left; Type: QD000P40CD; Serial: TP:1815
- Measurement SW: DASY52, Version 52.10 (2); SEMCAD X Version 14.6.12 (7470)

**Pin=250mW/Area Scan (61x61x1):** Interpolated grid: dx=1.500 mm, dy=1.500 mm

Maximum value of SAR (interpolated) = 15.6 W/kg

**Pin=250mW/Zoom Scan (5x5x7)/Cube 0:** Measurement grid: dx=8mm, dy=8mm, dz=5mm

Reference Value = 108.6 V/m; Power Drift = 0.12 dB

Peak SAR (extrapolated) = 18.3 W/kg

**SAR(1 g) = 9.82 W/kg; SAR(10 g) = 5.03 W/kg**

Maximum value of SAR (measured) = 15.3 W/kg

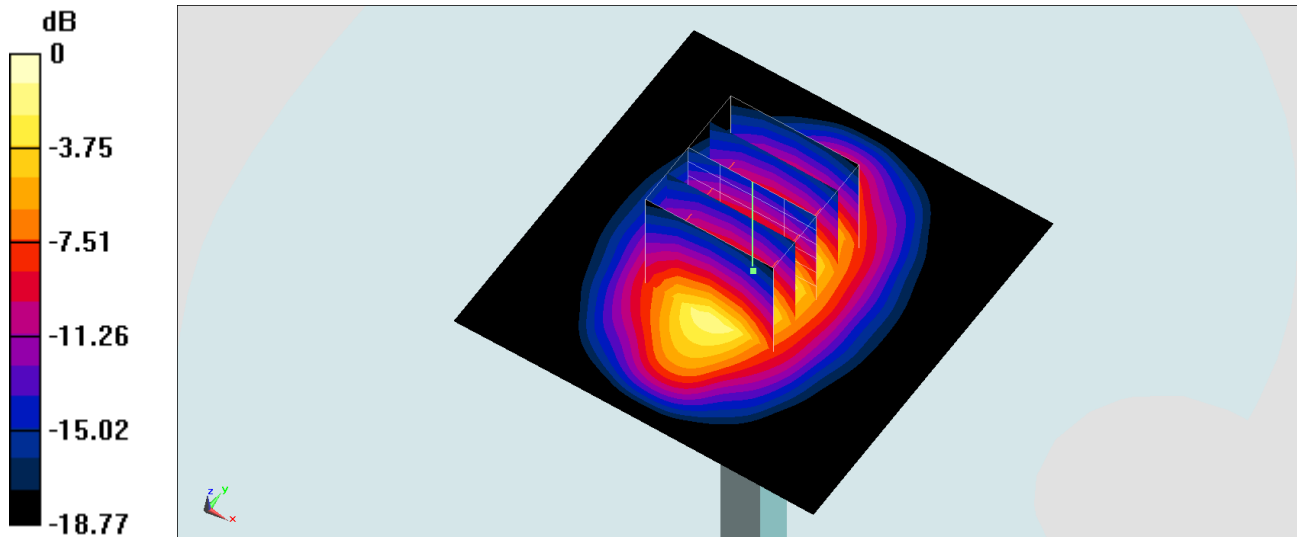

0 dB = 15.3 W/kg = 11.85 dBW/kg



## System Check\_Head\_1900MHz

### DUT: D1900V2-5d041

Communication System: CW; Frequency: 1900 MHz; Duty Cycle: 1:1

Medium: HSL\_1900\_190814 Medium parameters used:  $f = 1900$  MHz;  $\sigma = 1.424$  S/m;  $\epsilon_r = 38.958$ ;  $\rho = 1000$  kg/m<sup>3</sup>

Ambient Temperature : 23.2 °C; Liquid Temperature : 22.2 °C

DASY5 Configuration:

- Probe: EX3DV4 - SN3642; ConvF(7.91, 7.91, 7.91) @ 1900 MHz; Calibrated: 2019/4/29
- Sensor-Surface: 1.4mm (Mechanical Surface Detection)
- Electronics: DAE3 Sn360; Calibrated: 2018/10/29
- Phantom: SAM\_Left; Type: QD000P40CD; Serial: TP:1815
- Measurement SW: DASY52, Version 52.10 (2); SEMCAD X Version 14.6.12 (7470)

**Pin=250mW/Area Scan (61x61x1):** Interpolated grid: dx=1.500 mm, dy=1.500 mm

Maximum value of SAR (interpolated) = 15.3 W/kg

**Pin=250mW/Zoom Scan (5x5x7)/Cube 0:** Measurement grid: dx=8mm, dy=8mm, dz=5mm

Reference Value = 108.6 V/m; Power Drift = -0.07 dB

Peak SAR (extrapolated) = 18.0 W/kg

**SAR(1 g) = 9.66 W/kg; SAR(10 g) = 4.95 W/kg**

Maximum value of SAR (measured) = 15.1 W/kg

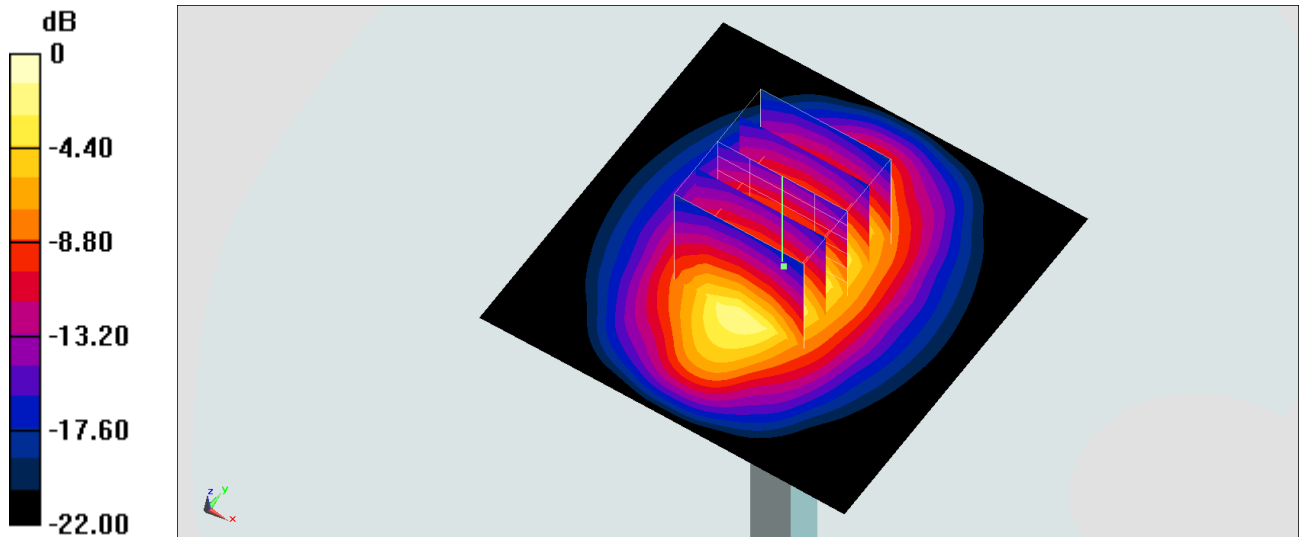

0 dB = 15.1 W/kg = 11.79 dBW/kg

## System Check\_Head\_1900MHz

### DUT: D1900V2-5d041

Communication System: CW; Frequency: 1900 MHz; Duty Cycle: 1:1

Medium: HSL\_1900\_190815 Medium parameters used:  $f = 1900$  MHz;  $\sigma = 1.384$  S/m;  $\epsilon_r = 40.37$ ;  $\rho = 1000$  kg/m<sup>3</sup>

Ambient Temperature : 23.6 °C ; Liquid Temperature : 22.6 °C

DASY5 Configuration:

- Probe: EX3DV4 - SN3642; ConvF(7.91, 7.91, 7.91) @ 1900 MHz; Calibrated: 2019/4/29
- Sensor-Surface: 1.4mm (Mechanical Surface Detection)
- Electronics: DAE3 Sn360; Calibrated: 2018/10/29
- Phantom: SAM\_Left; Type: QD000P40CD; Serial: TP:1815
- Measurement SW: DASY52, Version 52.10 (2); SEMCAD X Version 14.6.12 (7470)

**Pin=250mW/Area Scan (61x61x1):** Interpolated grid: dx=1.500 mm, dy=1.500 mm  
Maximum value of SAR (interpolated) = 14.9 W/kg

**Pin=250mW/Zoom Scan (5x5x7)/Cube 0:** Measurement grid: dx=8mm, dy=8mm, dz=5mm  
Reference Value = 108.6 V/m; Power Drift = -0.02 dB  
Peak SAR (extrapolated) = 17.5 W/kg  
**SAR(1 g) = 9.39 W/kg; SAR(10 g) = 4.81 W/kg**  
Maximum value of SAR (measured) = 14.6 W/kg

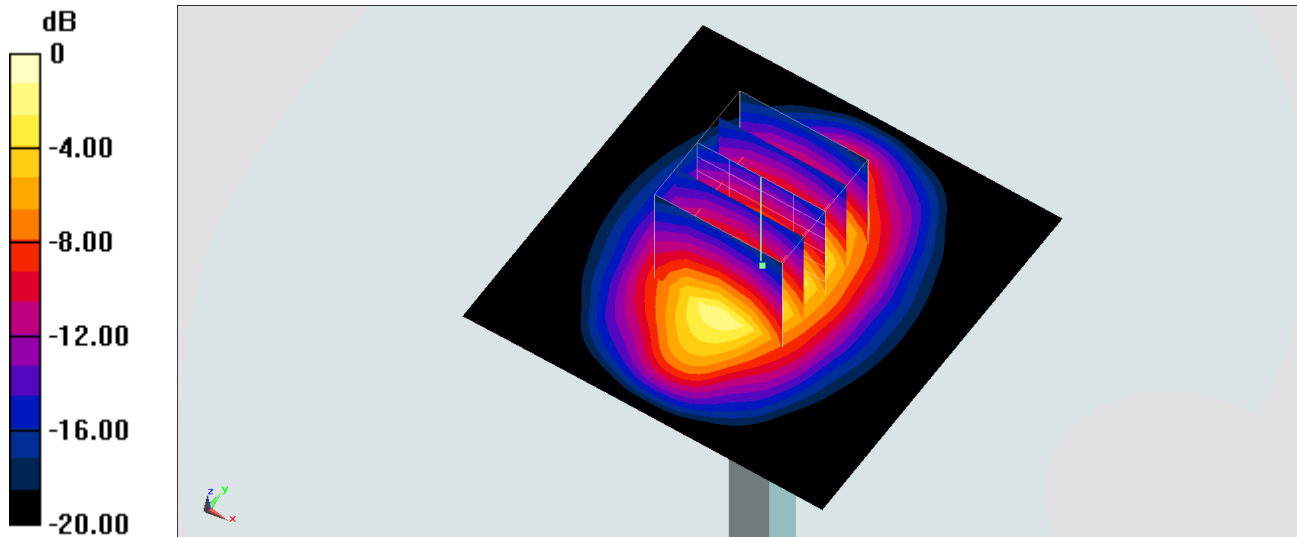

0 dB = 14.6 W/kg = 11.64 dBW/kg

## System Check\_Head\_2450MHz

### DUT: D2450V2-736

Communication System: CW; Frequency: 2450 MHz; Duty Cycle: 1:1

Medium: HSL\_2450\_190815 Medium parameters used :  $f = 2450$  MHz;  $\sigma = 1.835$  S/m;  $\epsilon_r = 38.775$ ;

$\rho = 1000$  kg/m<sup>3</sup>

Ambient Temperature : 23.8 °C ; Liquid Temperature : 22.8 °C

### DASY5 Configuration

- Probe: EX3DV4 - SN7346; ConvF(7.5, 7.5, 7.5) @ 2450 MHz; Calibrated: 2019/4/25

- Sensor-Surface: 1.4mm (Mechanical Surface Detection)

- Electronics: DAE4 Sn1326; Calibrated: 2018/9/18

- Phantom: Twin-SAM V5.0 (30deg probe tilt); Type: QD 000 P40 CD; Serial: 1885

- Measurement SW: DASY52, Version 52.10 (2); SEMCAD X Version 14.6.12 (7450)

**Pin=250mW/Area Scan (71x71x1):** Interpolated grid: dx=1.200 mm, dy=1.200 mm

Maximum value of SAR (interpolated) = 21.2 W/kg

**Pin=250mW/Zoom Scan (7x7x7)/Cube 0:** Measurement grid: dx=5mm, dy=5mm, dz=5mm

Reference Value = 111.7 V/m; Power Drift = -0.13 dB

Peak SAR (extrapolated) = 25.2 W/kg

**SAR(1 g) = 12.8 W/kg; SAR(10 g) = 6.04 W/kg**

Maximum value of SAR (measured) = 20.8 W/kg

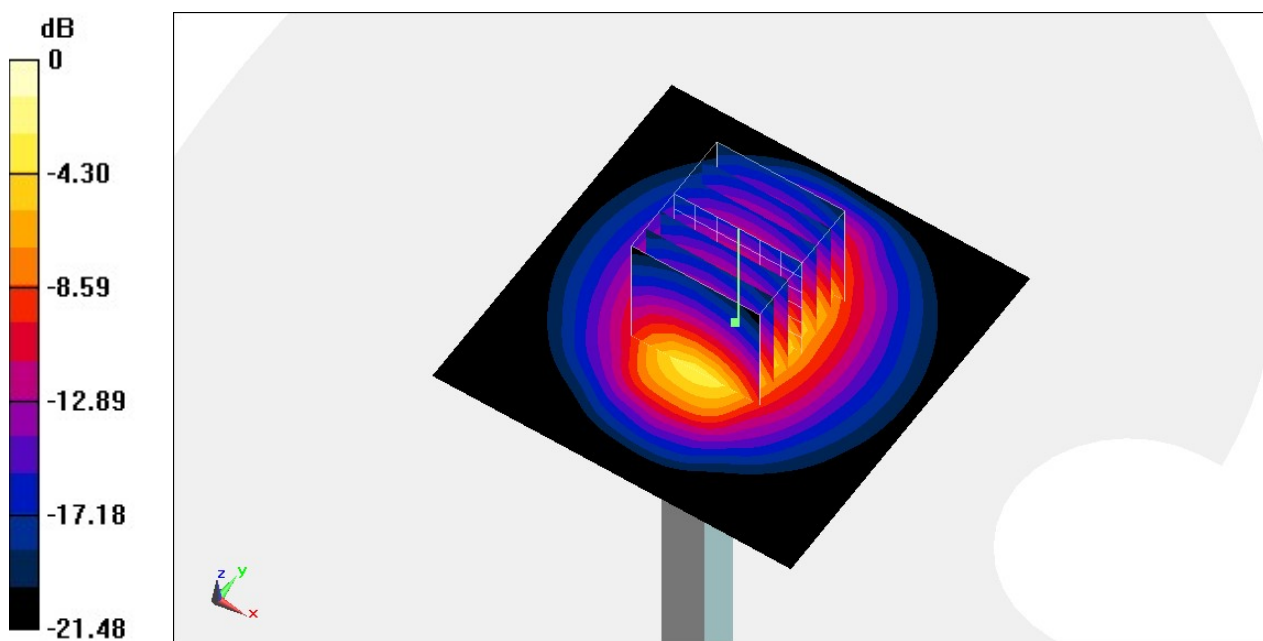

0 dB = 20.8 W/kg = 13.18 dBW/kg

## System Check\_Head\_2600MHz

### DUT: D2600V2-1008

Communication System: CW; Frequency: 2600 MHz; Duty Cycle: 1:1

Medium: HSL\_2600\_190809 Medium parameters used:  $f = 2600$  MHz;  $\sigma = 1.967$  S/m;  $\epsilon_r = 38.171$ ;  $\rho = 1000$  kg/m<sup>3</sup>

Ambient Temperature : 23.4 °C; Liquid Temperature : 22.4 °C

DASY5 Configuration:

- Probe: EX3DV4 - SN7306; ConvF(7.3, 7.3, 7.3) @ 2600 MHz; Calibrated: 2019/7/22
- Sensor-Surface: 1.4mm (Mechanical Surface Detection)
- Electronics: DAE3 Sn495; Calibrated: 2019/5/21
- Phantom: SAM\_Right; Type: QD000P40CD; Serial: 1884
- Measurement SW: DASY52, Version 52.10 (2); SEMCAD X Version 14.6.12 (7470)

**Pin=250mW/Area Scan (61x61x1):** Interpolated grid: dx=1.200 mm, dy=1.200 mm

Maximum value of SAR (interpolated) = 24.5 W/kg

**Pin=250mW/Zoom Scan (7x7x7)/Cube 0:** Measurement grid: dx=5mm, dy=5mm, dz=5mm

Reference Value = 113.8 V/m; Power Drift = -0.06 dB

Peak SAR (extrapolated) = 31.5 W/kg

**SAR(1 g) = 14.6 W/kg; SAR(10 g) = 6.44 W/kg**

Maximum value of SAR (measured) = 24.7 W/kg

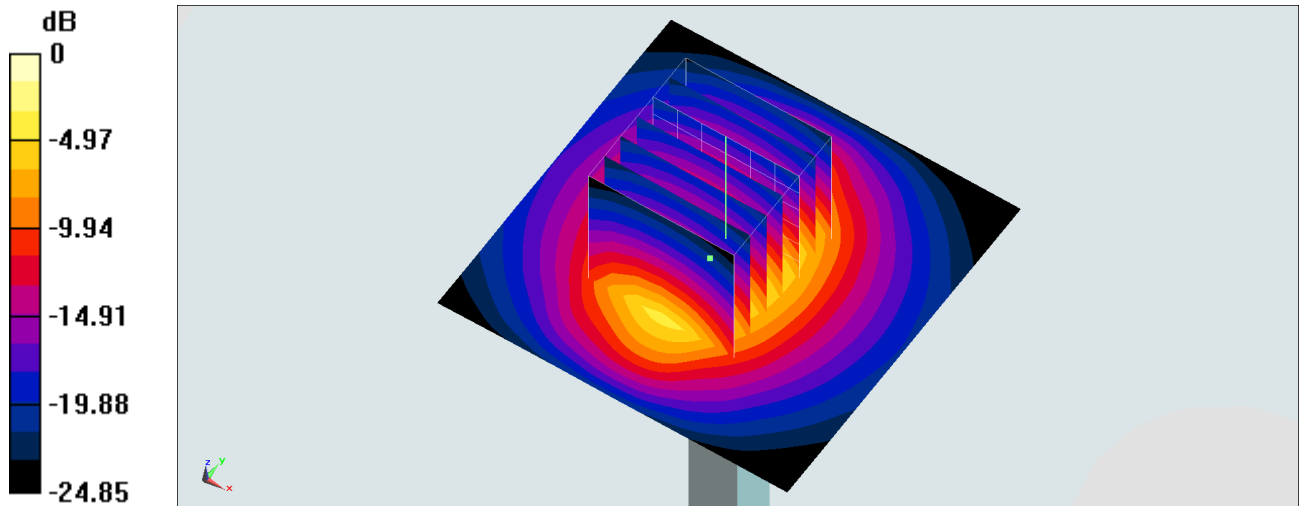

0 dB = 24.7 W/kg = 13.93 dBW/kg

## System Check\_Head\_2600MHz

### DUT: D2600V2-1008

Communication System: CW; Frequency: 2600 MHz; Duty Cycle: 1:1  
Medium: HSL\_2600\_190809 Medium parameters used:  $f = 2600$  MHz;  $\sigma = 1.967$  S/m;  $\epsilon_r = 38.722$ ;  
 $\rho = 1000$  kg/m<sup>3</sup>  
Ambient Temperature : 23.5 °C ; Liquid Temperature : 22.5 °C

### DASY5 Configuration

- Probe: ES3DV3 - SN3169; ConvF(4.38, 4.38, 4.38) @ 2600 MHz; Calibrated: 2019/5/24
- Sensor-Surface: 3mm (Mechanical Surface Detection)
- Electronics: DAE4 Sn1326; Calibrated: 2018/9/18
- Phantom: Twin-SAM V5.0 (30deg probe tilt); Type: QD 000 P40 CD; Serial: 1885
- Measurement SW: DASY52, Version 52.10 (2); SEMCAD X Version 14.6.12 (7450)

**Pin=250mW/Area Scan (81x81x1):** Interpolated grid: dx=1.200 mm, dy=1.200 mm  
Maximum value of SAR (interpolated) = 18.3 W/kg

**Pin=250mW/Zoom Scan (7x7x7)/Cube 0:** Measurement grid: dx=5mm, dy=5mm, dz=5mm  
Reference Value = 98.82 V/m; Power Drift = 0.05 dB  
Peak SAR (extrapolated) = 29.7 W/kg  
**SAR(1 g) = 13.7 W/kg; SAR(10 g) = 6.16 W/kg**  
Maximum value of SAR (measured) = 18.3 W/kg

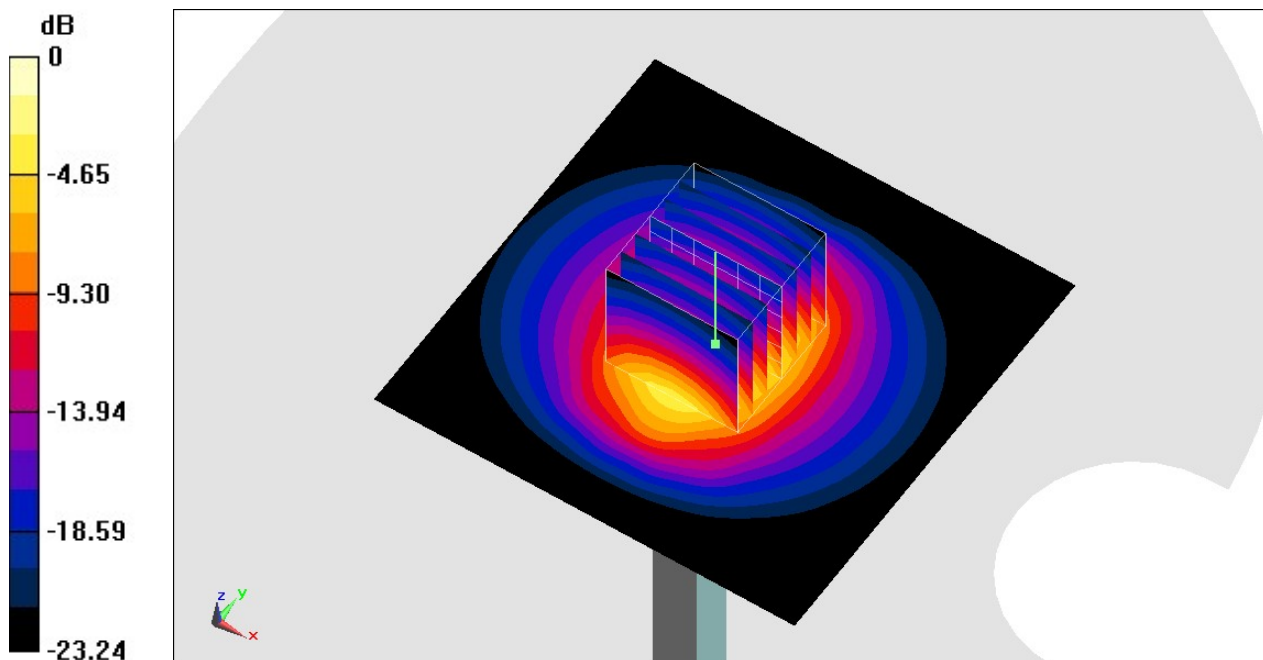

0 dB = 18.3 W/kg = 12.63 dBW/kg

## System Check\_Head\_2600MHz

### DUT: D2600V2-1008

Communication System: CW; Frequency: 2600 MHz; Duty Cycle: 1:1

Medium: HSL\_2600\_190814 Medium parameters used:  $f = 2600$  MHz;  $\sigma = 1.92$  S/m;  $\epsilon_r = 38.401$ ;  $\rho = 1000$  kg/m<sup>3</sup>

Ambient Temperature : 23.8 °C ; Liquid Temperature : 22.8 °C

### DASY5 Configuration

- Probe: EX3DV4 - SN7346; ConvF(7.31, 7.31, 7.31) @ 2600 MHz; Calibrated: 2019/4/25
- Sensor-Surface: 1.4mm (Mechanical Surface Detection)
- Electronics: DAE4 Sn1326; Calibrated: 2018/9/18
- Phantom: Twin-SAM V5.0 (30deg probe tilt); Type: QD 000 P40 CD; Serial: 1885
- Measurement SW: DASY52, Version 52.10 (2); SEMCAD X Version 14.6.12 (7450)

**Pin=250mW/Area Scan (71x71x1):** Interpolated grid: dx=1.200 mm, dy=1.200 mm  
Maximum value of SAR (interpolated) = 22.7 W/kg

**Pin=250mW/Zoom Scan (7x7x7)/Cube 0:** Measurement grid: dx=5mm, dy=5mm, dz=5mm  
Reference Value = 113.1 V/m; Power Drift = -0.17 dB  
Peak SAR (extrapolated) = 28.0 W/kg  
**SAR(1 g) = 14.2 W/kg; SAR(10 g) = 6.34 W/kg**  
Maximum value of SAR (measured) = 27.5 W/kg

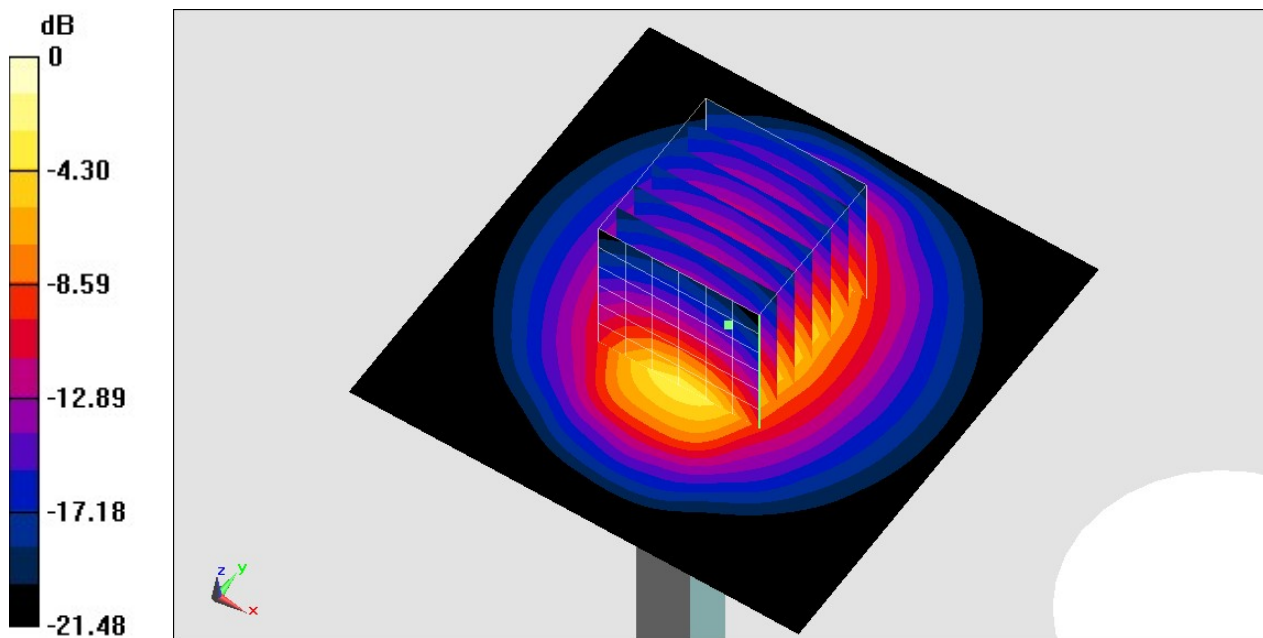

0 dB = 27.5 W/kg = 14.39 dBW/kg

## System Check\_Head\_5250MHz

### DUT: D5GHzV2-1006

Communication System: CW; Frequency: 5250 MHz; Duty Cycle: 1:1

Medium: HSL\_5G\_190816 Medium parameters used:  $f = 5250$  MHz;  $\sigma = 4.675$  S/m;  $\epsilon_r = 37.147$ ;  $\rho = 1000$  kg/m<sup>3</sup>

Ambient Temperature : 23.3 °C ; Liquid Temperature : 22.3 °C

DASY5 Configuration:

- Probe: EX3DV4 - SN3642; ConvF(4.54, 4.54, 4.54) @ 5250 MHz; Calibrated: 2019/4/29
- Sensor-Surface: 1.4mm (Mechanical Surface Detection)
- Electronics: DAE3 Sn360; Calibrated: 2018/10/29
- Phantom: SAM\_Right; Type: SAM; Serial: TP:1446
- Measurement SW: DASY52, Version 52.10 (2); SEMCAD X Version 14.6.12 (7470)

**Pin=100mW/Area Scan (71x71x1):** Interpolated grid: dx=1.000 mm, dy=1.000 mm  
Maximum value of SAR (interpolated) = 20.5 W/kg

**Pin=100mW/Zoom Scan (7x7x7)/Cube 0:** Measurement grid: dx=4mm, dy=4mm, dz=1.4mm  
Reference Value = 74.56 V/m; Power Drift = 0.03 dB  
Peak SAR (extrapolated) = 34.0 W/kg  
**SAR(1 g) = 8.52 W/kg; SAR(10 g) = 2.34 W/kg**  
Maximum value of SAR (measured) = 21.2 W/kg

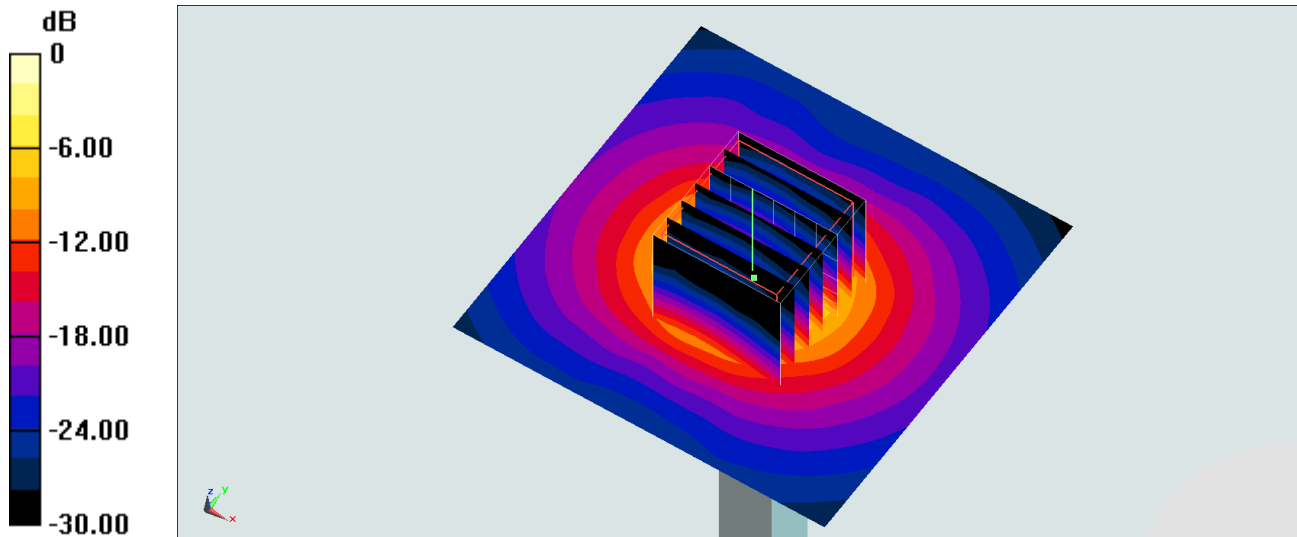

## System Check\_Head\_5250MHz

### DUT: D5GHzV2-1006

Communication System: CW; Frequency: 5250 MHz; Duty Cycle: 1:1

Medium: HSL\_5G\_190817 Medium parameters used:  $f = 5250$  MHz;  $\sigma = 4.694$  S/m;  $\epsilon_r = 36.305$ ;  $\rho = 1000$  kg/m<sup>3</sup>

Ambient Temperature : 23.7 °C ; Liquid Temperature : 22.7 °C

DASY5 Configuration:

- Probe: EX3DV4 - SN3642; ConvF(4.54, 4.54, 4.54) @ 5250 MHz; Calibrated: 2019/4/29
- Sensor-Surface: 1.4mm (Mechanical Surface Detection)
- Electronics: DAE3 Sn360; Calibrated: 2018/10/29
- Phantom: SAM\_Right; Type: SAM; Serial: TP:1446
- Measurement SW: DASY52, Version 52.10 (2); SEMCAD X Version 14.6.12 (7470)

**Pin=100mW/Area Scan (71x71x1):** Interpolated grid: dx=1.000 mm, dy=1.000 mm

Maximum value of SAR (interpolated) = 20.5 W/kg

**Pin=100mW/Zoom Scan (7x7x7)/Cube 0:** Measurement grid: dx=4mm, dy=4mm, dz=1.4mm

Reference Value = 74.56 V/m; Power Drift = 0.13 dB

Peak SAR (extrapolated) = 34.1 W/kg

**SAR(1 g) = 8.55 W/kg; SAR(10 g) = 2.35 W/kg**

Maximum value of SAR (measured) = 21.3 W/kg

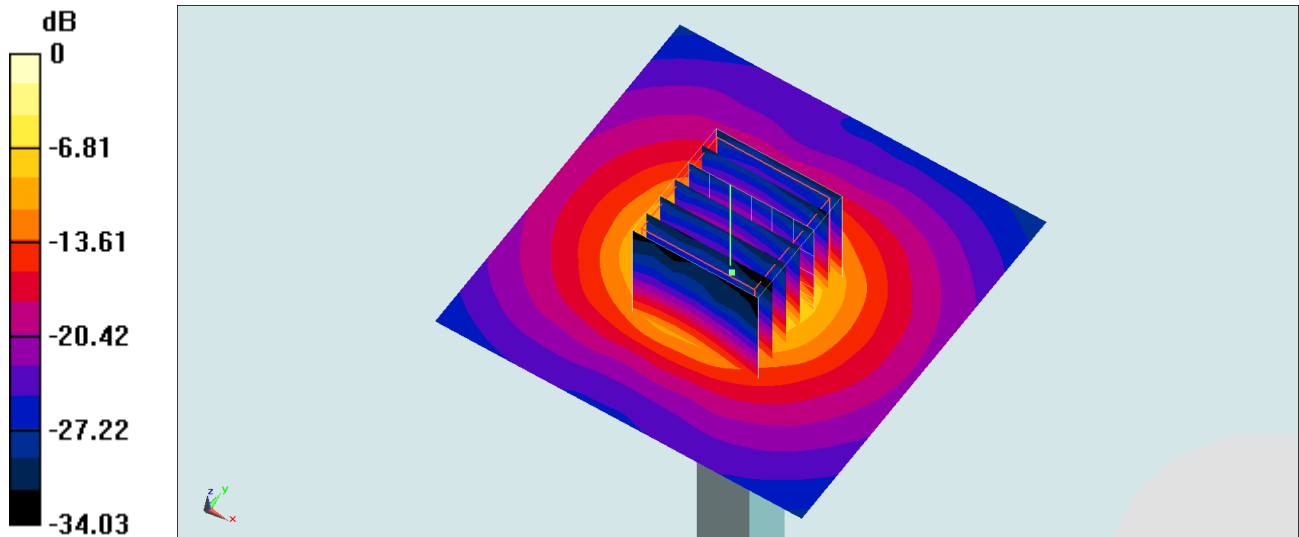

0 dB = 21.3 W/kg = 13.28 dBW/kg



## System Check\_Head\_5600MHz

### DUT: D5GHzV2-1006

Communication System: CW; Frequency: 5600 MHz; Duty Cycle: 1:1

Medium: HSL\_5G\_190816 Medium parameters used:  $f = 5600$  MHz;  $\sigma = 5.067$  S/m;  $\epsilon_r = 36.805$ ;  $\rho = 1000$  kg/m<sup>3</sup>

Ambient Temperature : 23.3 °C; Liquid Temperature : 22.3 °C

DASY5 Configuration:

- Probe: EX3DV4 - SN3642; ConvF(4.28, 4.28, 4.28) @ 5600 MHz; Calibrated: 2019/4/29
- Sensor-Surface: 1.4mm (Mechanical Surface Detection)
- Electronics: DAE3 Sn360; Calibrated: 2018/10/29
- Phantom: SAM\_Right; Type: SAM; Serial: TP:1446
- Measurement SW: DASY52, Version 52.10 (2); SEMCAD X Version 14.6.12 (7470)

**Pin=100mW/Area Scan (71x71x1):** Interpolated grid: dx=1.000 mm, dy=1.000 mm  
Maximum value of SAR (interpolated) = 21.8 W/kg

**Pin=100mW/Zoom Scan (7x7x7)/Cube 0:** Measurement grid: dx=4mm, dy=4mm, dz=1.4mm  
Reference Value = 72.98 V/m; Power Drift = 0.03 dB  
Peak SAR (extrapolated) = 37.2 W/kg  
**SAR(1 g) = 8.65 W/kg; SAR(10 g) = 2.35 W/kg**  
Maximum value of SAR (measured) = 22.0 W/kg

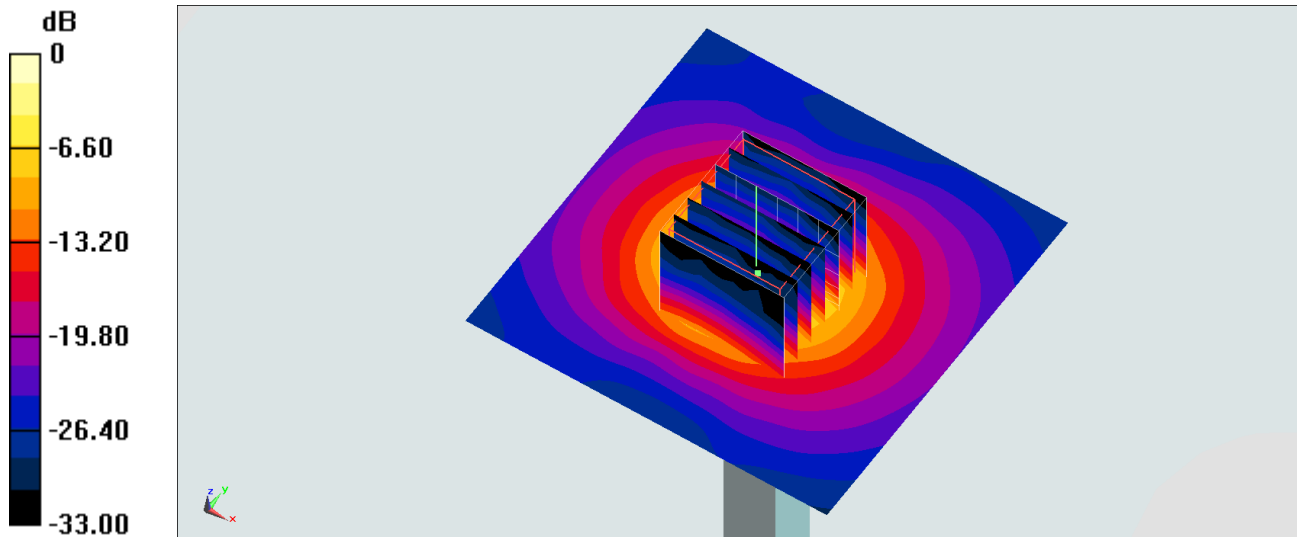

0 dB = 22.0 W/kg = 13.42 dBW/kg

## System Check\_Head\_5600MHz

### DUT: D5GHzV2-1006

Communication System: CW; Frequency: 5600 MHz; Duty Cycle: 1:1

Medium: HSL\_5G\_190817 Medium parameters used:  $f = 5600$  MHz;  $\sigma = 5.032$  S/m;  $\epsilon_r = 35.852$ ;  $\rho = 1000$  kg/m<sup>3</sup>

Ambient Temperature : 23.7 °C; Liquid Temperature : 22.7 °C

DASY5 Configuration:

- Probe: EX3DV4 - SN3642; ConvF(4.28, 4.28, 4.28) @ 5600 MHz; Calibrated: 2019/4/29
- Sensor-Surface: 1.4mm (Mechanical Surface Detection)
- Electronics: DAE3 Sn360; Calibrated: 2018/10/29
- Phantom: SAM\_Right; Type: SAM; Serial: TP:1446
- Measurement SW: DASY52, Version 52.10 (2); SEMCAD X Version 14.6.12 (7470)

**Pin=100mW/Area Scan (71x71x1):** Interpolated grid: dx=1.000 mm, dy=1.000 mm  
Maximum value of SAR (interpolated) = 21.7 W/kg

**Pin=100mW/Zoom Scan (7x7x7)/Cube 0:** Measurement grid: dx=4mm, dy=4mm, dz=1.4mm  
Reference Value = 72.98 V/m; Power Drift = 0.14 dB  
Peak SAR (extrapolated) = 37.0 W/kg  
**SAR(1 g) = 8.59 W/kg; SAR(10 g) = 2.34 W/kg**  
Maximum value of SAR (measured) = 21.9 W/kg

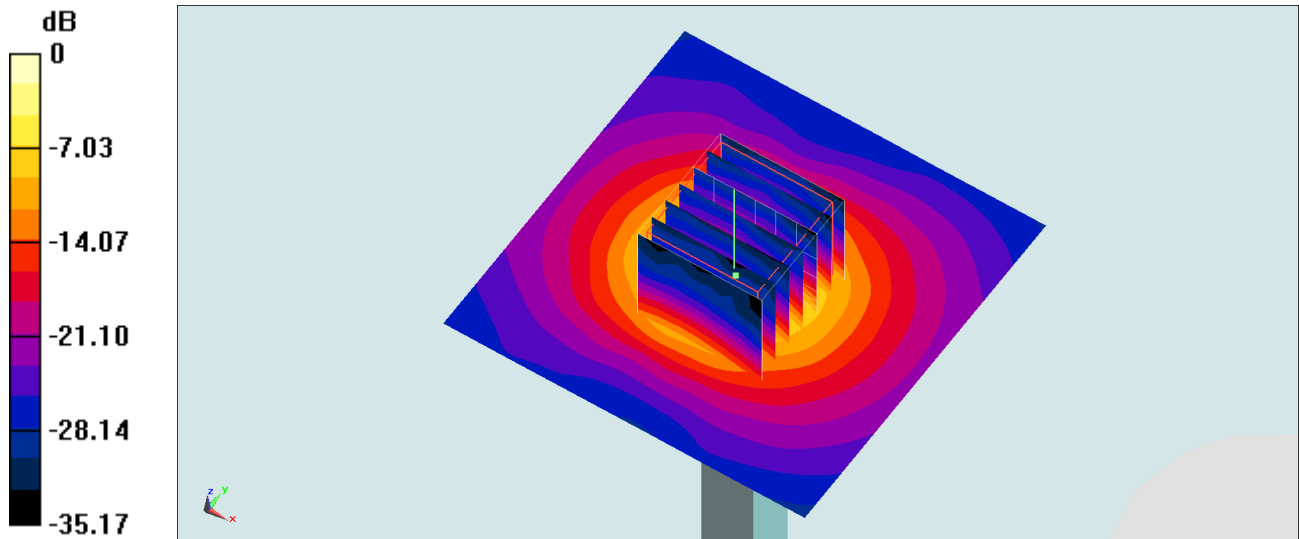

0 dB = 21.9 W/kg = 13.40 dBW/kg

## System Check\_Head\_5750MHz

### DUT: D5GHzV2-1006

Communication System: CW; Frequency: 5750 MHz; Duty Cycle: 1:1

Medium: HSL\_5G\_190816 Medium parameters used:  $f = 5750$  MHz;  $\sigma = 5.222$  S/m;  $\epsilon_r = 36.347$ ;  $\rho = 1000$  kg/m<sup>3</sup>

Ambient Temperature : 23.3 °C; Liquid Temperature : 22.3 °C

DASY5 Configuration:

- Probe: EX3DV4 - SN3642; ConvF(4.36, 4.36, 4.36) @ 5750 MHz; Calibrated: 2019/4/29
- Sensor-Surface: 1.4mm (Mechanical Surface Detection)
- Electronics: DAE3 Sn360; Calibrated: 2018/10/29
- Phantom: SAM\_Right; Type: SAM; Serial: TP:1446
- Measurement SW: DASY52, Version 52.10 (2); SEMCAD X Version 14.6.12 (7470)

**Pin=100mW/Area Scan (71x71x1):** Interpolated grid: dx=1.000 mm, dy=1.000 mm

Maximum value of SAR (interpolated) = 19.9 W/kg

**Pin=100mW/Zoom Scan (7x7x7)/Cube 0:** Measurement grid: dx=4mm, dy=4mm, dz=1.4mm

Reference Value = 66.98 V/m; Power Drift = -0.15 dB

Peak SAR (extrapolated) = 38.0 W/kg

**SAR(1 g) = 7.98 W/kg; SAR(10 g) = 2.14 W/kg**

Maximum value of SAR (measured) = 21.3 W/kg

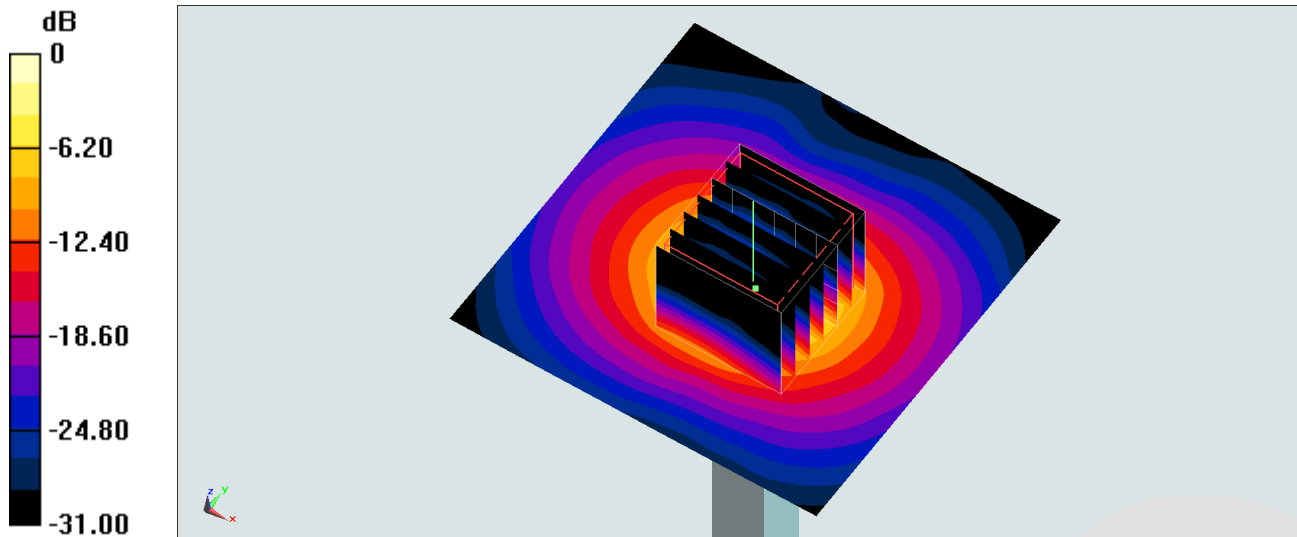

0 dB = 21.3 W/kg = 13.28 dBW/kg