



FCC RADIO TEST REPORT

FCC ID : IHDT56XS1
Equipment : Mobile Cellular Phone
Brand Name : Motorola
Model Name : XT1980-4
Applicant : Motorola Mobility LLC
222 W, Merchandise Mart Plaza, Chicago IL 60654 USA
Manufacturer : Motorola Mobility LLC
222 W, Merchandise Mart Plaza, Chicago IL 60654 USA
Standard : FCC Part 15 Subpart C §15.247

The product was received on Mar. 05, 2019 and testing was started from Mar. 21, 2019 and completed on Mar. 29, 2019. We, SPORTON INTERNATIONAL INC. EMC & Wireless Communications Laboratory, would like to declare that the tested sample has been evaluated in accordance with the test procedures and has been in compliance with the applicable technical standards.

The report must not be used by the client to claim product certification, approval, or endorsement by TAF or any agency of government.

The test results in this partial report apply exclusively to the tested model / sample. Without written approval of SPORTON INTERNATIONAL INC. EMC & Wireless Communications Laboratory, the test report shall not be reproduced except in full.

Approved by: Jones Tsai

SPORTON INTERNATIONAL INC. EMC & Wireless Communications Laboratory
No. 52, Huaya 1st Rd., Guishan Dist., Taoyuan City, Taiwan (R.O.C.)



Table of Contents

History of this test report..... 3

Summary of Test Result..... 4

1 General Description..... 5

 1.1 Product Feature of Equipment Under Test..... 5

 1.2 Product Specification of Equipment Under Test..... 5

 1.3 Modification of EUT 5

 1.4 Testing Location 6

 1.5 Applicable Standards..... 6

2 Test Configuration of Equipment Under Test 7

 2.1 Carrier Frequency Channel 7

 2.2 Test Mode..... 8

 2.3 Connection Diagram of Test System..... 9

 2.4 Support Unit used in test configuration and system 11

 2.5 EUT Operation Test Setup 11

3 Test Result..... 12

 3.1 Radiated Band Edges and Spurious Emission Measurement 12

 3.2 AC Conducted Emission Measurement..... 16

4 List of Measuring Equipment 18

5 Uncertainty of Evaluation..... 19

Appendix A. AC Conducted Emission Test Result

Appendix B. Radiated Spurious Emission

Appendix C. Radiated Spurious Emission Plots

Appendix D. Duty Cycle Plots



History of this test report

Report No.	Version	Description	Issued Date
FR930415-06B	01	Initial issue of report	Apr. 10, 2019



Summary of Test Result

Report Clause	Ref Std. Clause	Test Items	Result (PASS/FAIL)	Remark
3.1	15.247(d)	Radiated Band Edges and Spurious Emission	Pass	Under limit 6.06 dB at 45.520 MHz
3.2	15.207	AC Conducted Emission	Pass	Under limit 10.19 dB at 0.211 MHz

Declaration of Conformity:
The test results with all measurement uncertainty excluded are presented in accordance with the regulation limits or requirements declared by manufacturers.
Comments and Explanations:
The declared of product specification for EUT presented in the report are provided by the manufacturer, and the manufacturer takes all the responsibilities for the accuracy of product specification.

Reviewed by: Wii Chang

Report Producer: Aileen Huang



1 General Description

1.1 Product Feature of Equipment Under Test

Product Feature	
Equipment	Mobile Cellular Phone
Brand Name	Motorola
Model Name	XT1980-4
FCC ID	IHDT56XS1
IMEI Code	Conduction : 352157100008509 Radiation : 352157100011206
EUT supports Radios application	CDMA/EV-DO/GSM/EGPRS/WCDMA/HSPA/LTE/GNSS/NFC/FM/WPC WLAN 11a/b/g/n HT20/HT40 WLAN 11ac VHT20/VHT40/VHT80 Bluetooth BR/EDR/LE
HW Version	DVT2
EUT Stage	Identical Prototype

Remark: The above EUT's information was declared by manufacturer.

Accessory List	
WPC Cover	Brand Name : Motorola
	Model Name : MD100W

1.2 Product Specification of Equipment Under Test

Standards-related Product Specification	
Tx/Rx Frequency Range	2402 MHz ~ 2480 MHz
Number of Channels	40
Carrier Frequency of Each Channel	40 Channel(37 hopping + 3 advertising channel)
Antenna Type / Gain	Loop Antenna with gain -8.0 dBi
Type of Modulation	Bluetooth LE : GFSK

1.3 Modification of EUT

No modifications are made to the EUT during all test items.



1.4 Testing Location

Test Site	SPORTON INTERNATIONAL INC.
Test Site Location	No.52, Huaya 1st Rd., Guishan Dist., Taoyuan City, Taiwan (R.O.C.) TEL: +886-3-327-3456 FAX: +886-3-328-4978
Test Site No.	Sporton Site No.
	CO05-HY

Note: The test site complies with ANSI C63.4 2014 requirement.

Test Site	SPORTON INTERNATIONAL INC.
Test Site Location	No.58, Aly. 75, Ln. 564, Wenhua 3rd, Rd., Guishan Dist., Taoyuan City, Taiwan (R.O.C.) TEL: +886-3-327-0868 FAX: +886-3-327-0855
Test Site No.	Sporton Site No.
	03CH11-HY

Note: The test site complies with ANSI C63.4 2014 requirement.

FCC Designation No. TW1190 and TW0007

1.5 Applicable Standards

According to the specifications of the manufacturer, the EUT must comply with the requirements of the following standards:

- ♦ FCC Part 15 Subpart C §15.247
- ♦ FCC KDB Publication No. 558074 D01 DTS Meas. Guidance v05r01
- ♦ FCC KDB 414788 D01 Radiated Test Site v01r01.
- ♦ ANSI C63.10-2013

Remark:

1. All test items were verified and recorded according to the standards and without any deviation during the test.
2. This EUT has also been tested and complied with the requirements of FCC Part 15, Subpart B, recorded in a separate test report.



2 Test Configuration of Equipment Under Test

2.1 Carrier Frequency Channel

Frequency Band	Channel	Freq. (MHz)	Channel	Freq. (MHz)
2400-2483.5 MHz	0	2402	21	2444
	1	2404	22	2446
	2	2406	23	2448
	3	2408	24	2450
	4	2410	25	2452
	5	2412	26	2454
	6	2414	27	2456
	7	2416	28	2458
	8	2418	29	2460
	9	2420	30	2462
	10	2422	31	2464
	11	2424	32	2466
	12	2426	33	2468
	13	2428	34	2470
	14	2430	35	2472
	15	2432	36	2474
	16	2434	37	2476
	17	2436	38	2478
	18	2438	39	2480
	19	2440	-	-
20	2442	-	-	



2.2 Test Mode

- a. The EUT has been associated with peripherals and configuration operated in a manner tended to maximize its emission characteristics in a typical application. Frequency range investigated: conduction emission (150 kHz to 30 MHz), radiation emission (9 kHz to the 10th harmonic of the highest fundamental frequency or to 40 GHz, whichever is lower).
- b. AC power line Conducted Emission was tested under maximum output power.

The following summary table is showing all test modes to demonstrate in compliance with the standard.

Summary table of Test Cases	
Test Item	Data Rate / Modulation
	Bluetooth – LE / GFSK
Radiated Test Cases	Mode 1:Bluetooth Tx CH39_2480 MHz_1Mbps for WPC Charging Mode Mode 2:Bluetooth Tx CH39_2480 MHz_1Mbps for PMA Charging Mode
AC Conducted Emission	Mode 1: GSM850 Idle + Bluetooth Link + WLAN Link + Camera + Battery + WPC Back Cover + LG Charging Pad + USB Cable (Charging from Adapter) + SIM 1 Mode 2: WCDMA Band V Idle + Bluetooth Link + WLAN Link + MPEG4 + Battery + WPC Back Cover + PMA Charging Pad + Adapter + SIM 1
Remark: The worst case of conducted emission is mode 2; only the test data of it was reported.	

2.3 Connection Diagram of Test System

<Bluetooth – LE Tx with WPC Charging Mode>

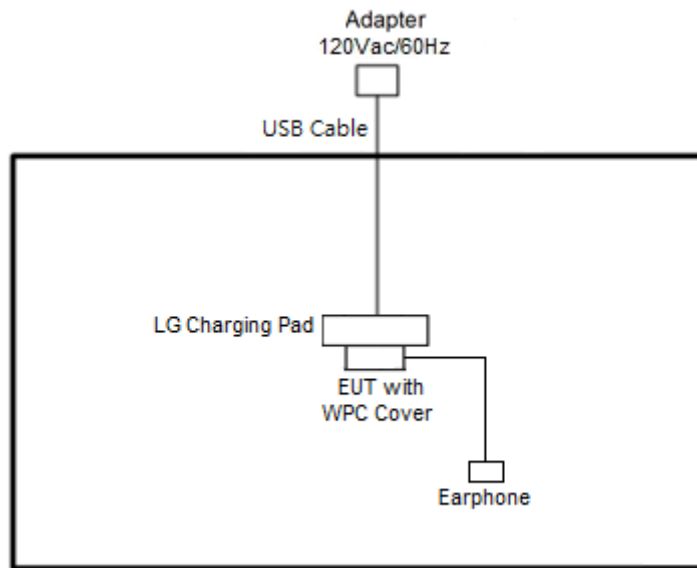

<Bluetooth – LE Tx with PMA Charging Mode>

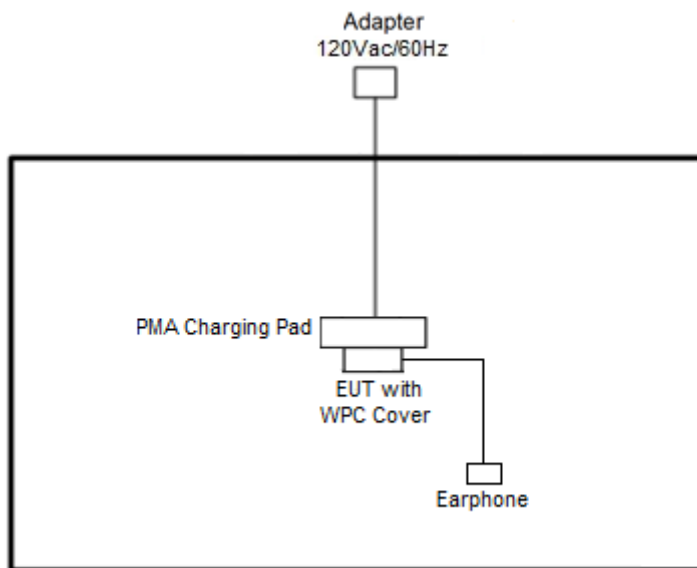

<AC Conducted Emission with WPC Charging Mode>

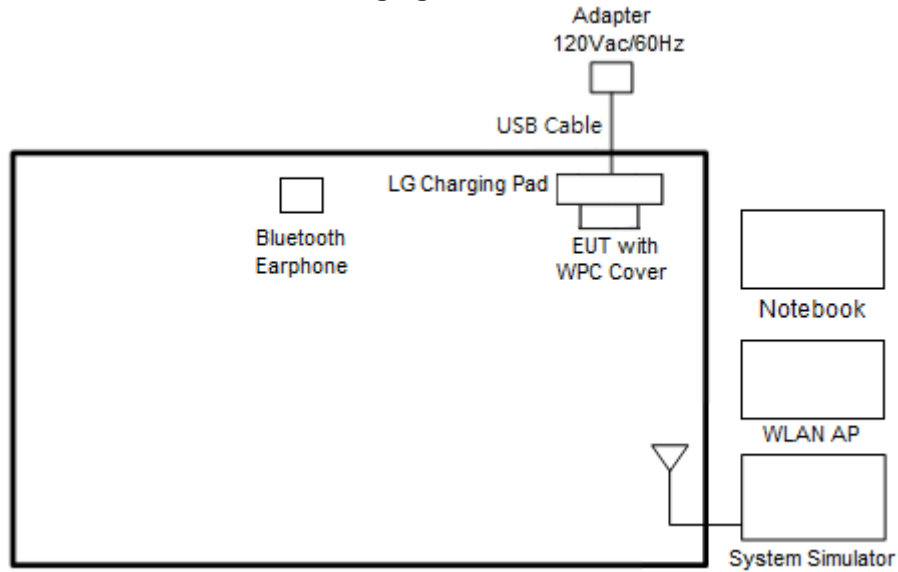

<AC Conducted Emissions with PMA Charging Mode>

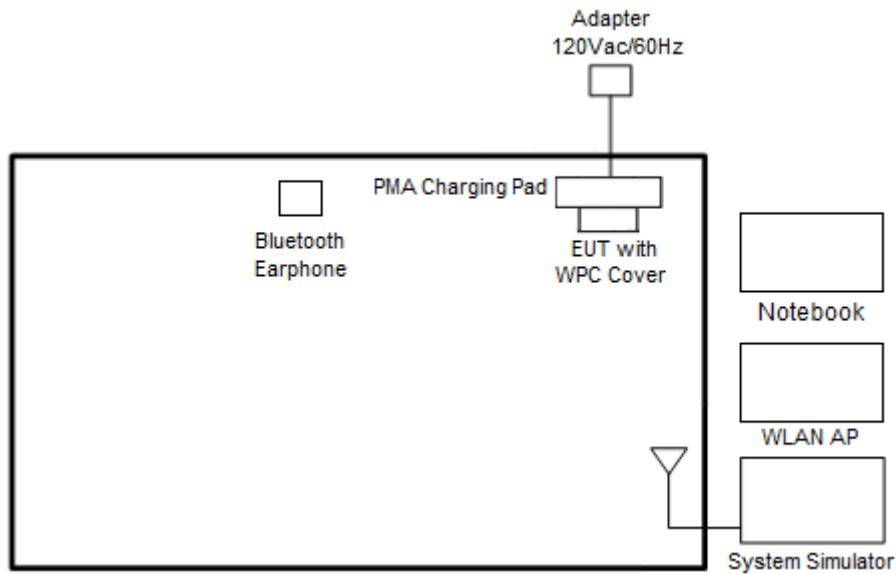



2.4 Support Unit used in test configuration and system

Item	Equipment	Trade Name	Model Name	FCC ID	Data Cable	Power Cord
1.	System Simulator	Anritsu	MT8820C	N/A	N/A	Unshielded, 1.8 m
2.	WLAN AP	ASUS	RT-AC66U	MSQ-RTAC66U	N/A	Unshielded,1.8m
3.	Bluetooth Earphone	Sony Ericsson	MW600	PY7DDA-2029	N/A	N/A
4.	Notebook	DELL	Latitude E6320	FCC DoC/ Contains FCC ID: QDS-BRCM1054	N/A	AC I/P: Unshielded, 1.2 m DC O/P: Shielded, 1.8 m
5.	LG Charging Pad	LG	WCD-110	FCC DoC	N/A	N/A
6.	PMA Charging Pad	DURACELL	M-018B518A	FCC DoC	N/A	N/A
7.	USB Cable	N/A	N/A	N/A	N/A	N/A
8.	Adapter	N/A	N/A	N/A	N/A	N/A
9.	Earphone	Moto	SH38C16618	FCC DoC	Unshielded, 1.0 m	N/A
10.	SD Card	SanDisk	MicroSD HC	FCC DoC	N/A	N/A

2.5 EUT Operation Test Setup

The RF test items, utility "QRCT" was installed in Notebook which was programmed in order to make the EUT get into the engineering modes to provide channel selection, power level, data rate and the application type and for continuous transmitting signals.



3 Test Result

3.1 Radiated Band Edges and Spurious Emission Measurement

3.1.1 Limit of Radiated Band Edges and Spurious Emission

In any 100 kHz bandwidth outside the intentional radiator frequency band, all harmonics/spurious must be at least 20 dB below the highest emission level within the authorized band. If the output power of this device was measured by spectrum analyzer, the attenuation under this paragraph shall be 30 dB instead of 20 dB. In addition, radiated emissions which fall in the restricted bands must also comply with the limits as below.

Frequency (MHz)	Field Strength (microvolts/meter)	Measurement Distance (meters)
0.009 – 0.490	2400/F(kHz)	300
0.490 – 1.705	24000/F(kHz)	30
1.705 – 30.0	30	30
30 – 88	100	3
88 – 216	150	3
216 - 960	200	3
Above 960	500	3

3.1.2 Measuring Instruments

See list of measuring equipment of this test report.

**3.1.3 Test Procedures**

1. The testing follows the ANSI C63.10 Section 11.12.1 Radiated emission measurements.
2. The EUT was arranged to its worst case and then tune the antenna tower (from 1 m to 4 m) and turntable (from 0 degree to 360 degrees) to find the maximum reading. A pre-amp and a high pass filter are used for the test in order to get better signal level.
3. The EUT was placed on a turntable with 0.8 meter for frequency below 1GHz and 1.5 meter for frequency above 1GHz respectively above ground.
4. The EUT was set 3 meters from the interference receiving antenna, which was mounted on the top of a variable height antenna tower.
5. Corrected Reading: Antenna Factor + Cable Loss + Read Level - Preamp Factor = Level
6. For testing below 1GHz, if the emission level of the EUT in peak mode was 3 dB lower than the limit specified, then peak values of EUT will be reported, otherwise, the emissions will be repeated one by one using the CISPR quasi-peak method and reported.
7. For testing above 1GHz, the emission level of the EUT in peak mode was 20dB lower than average limit (that means the emission level in average mode also complies with the limit in average mode), then peak values of EUT will be reported, otherwise, the emissions will be measured in average mode again and reported.
8. Use the following spectrum analyzer settings:
 - (1) Span shall wide enough to fully capture the emission being measured;
 - (2) Set RBW=100 kHz for $f < 1$ GHz; $VBW \geq RBW$; Sweep = auto; Detector function = peak; Trace = max hold;
 - (3) Set RBW = 1 MHz, VBW= 3MHz for $f \geq 1$ GHz for peak measurement.
For average measurement:
 - $VBW = 10$ Hz, when duty cycle is no less than 98 percent.
 - $VBW \geq 1/T$, when duty cycle is less than 98 percent where T is the minimum transmission duration over which the transmitter is on and is transmitting at its maximum power control level for the tested mode of operation.

3.1.4 Test Setup

For radiated emissions below 30MHz

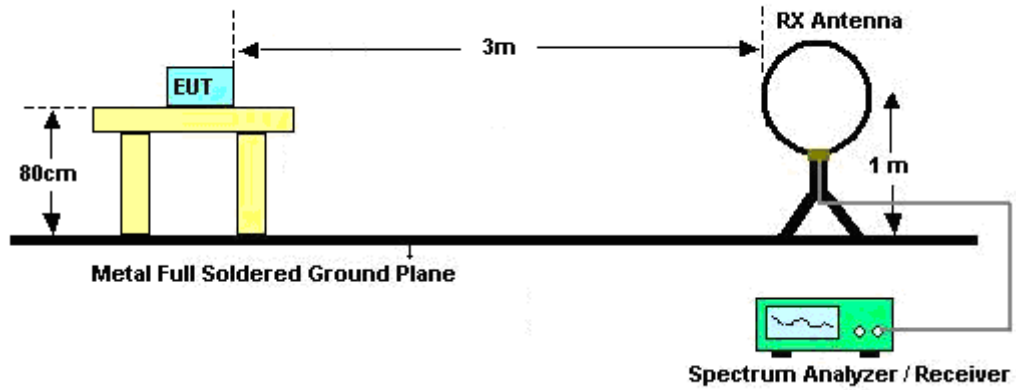

For radiated emissions from 30MHz to 1GHz

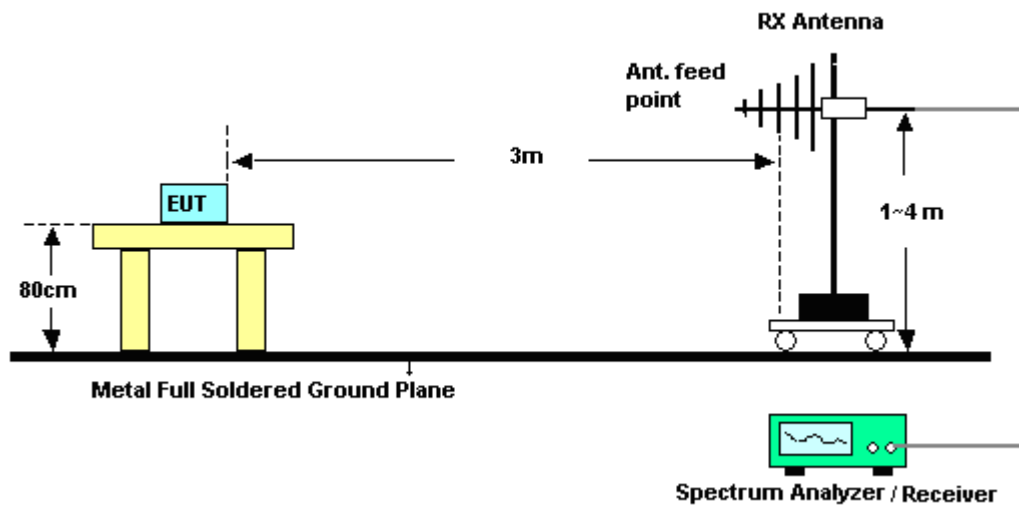

For radiated emissions above 1GHz

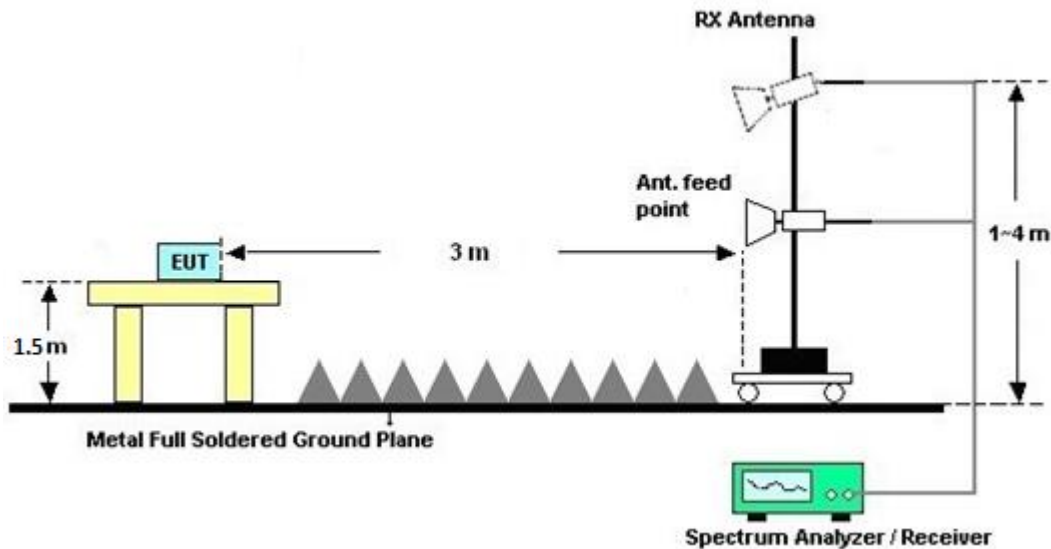

3.1.5 Test Results of Radiated Spurious Emissions (9 kHz ~ 30 MHz)

The low frequency, which started from 9 kHz to 30MHz, was pre-scanned and the result which was 20dB lower than the limit line was not reported.

There is a comparison data of both open-field test site and alternative test site - semi-Anechoic chamber according to 414788 D01 Radiated Test Site v01r01, and the result came out very similar.

3.1.6 Test Result of Radiated Spurious at Band Edges

Please refer to Appendix B and C.

3.1.7 Duty Cycle

Please refer to Appendix D.

3.1.8 Test Result of Radiated Spurious Emission (30MHz ~ 10th Harmonic)

Please refer to Appendix B and C.



3.2 AC Conducted Emission Measurement

3.2.1 Limit of AC Conducted Emission

For equipment that is designed to be connected to the public utility (AC) power line, the radio frequency voltage that is conducted back onto the AC power line on any frequency or frequencies within the band 150 kHz to 30 MHz shall not exceed the limits in the following table.

Frequency of emission (MHz)	Conducted limit (dB μ V)	
	Quasi-peak	Average
0.15-0.5	66 to 56*	56 to 46*
0.5-5	56	46
5-30	60	50

*Decreases with the logarithm of the frequency.

3.2.2 Measuring Instruments

See list of measuring equipment of this test report.

3.2.3 Test Procedures

1. The EUT was placed 0.4 meter from the conducting wall of the shielding room was kept at least 80 centimeters from any other grounded conducting surface.
2. Connect EUT to the power mains through a line impedance stabilization network (LISN).
3. All the support units are connecting to the other LISN.
4. The LISN provides 50 ohm coupling impedance for the measuring instrument.
5. The FCC states that a 50 ohm, 50 microhenry LISN should be used.
6. Both sides of AC line were checked for maximum conducted interference.
7. The frequency range from 150 kHz to 30 MHz was searched.
8. Set the test-receiver system to Peak Detect Function and specified bandwidth (IF Bandwidth = 9kHz) with Maximum Hold Mode. Then measurement is also conducted by Average Detector and Quasi-Peak Detector Function respectively.

3.2.4 Test Setup

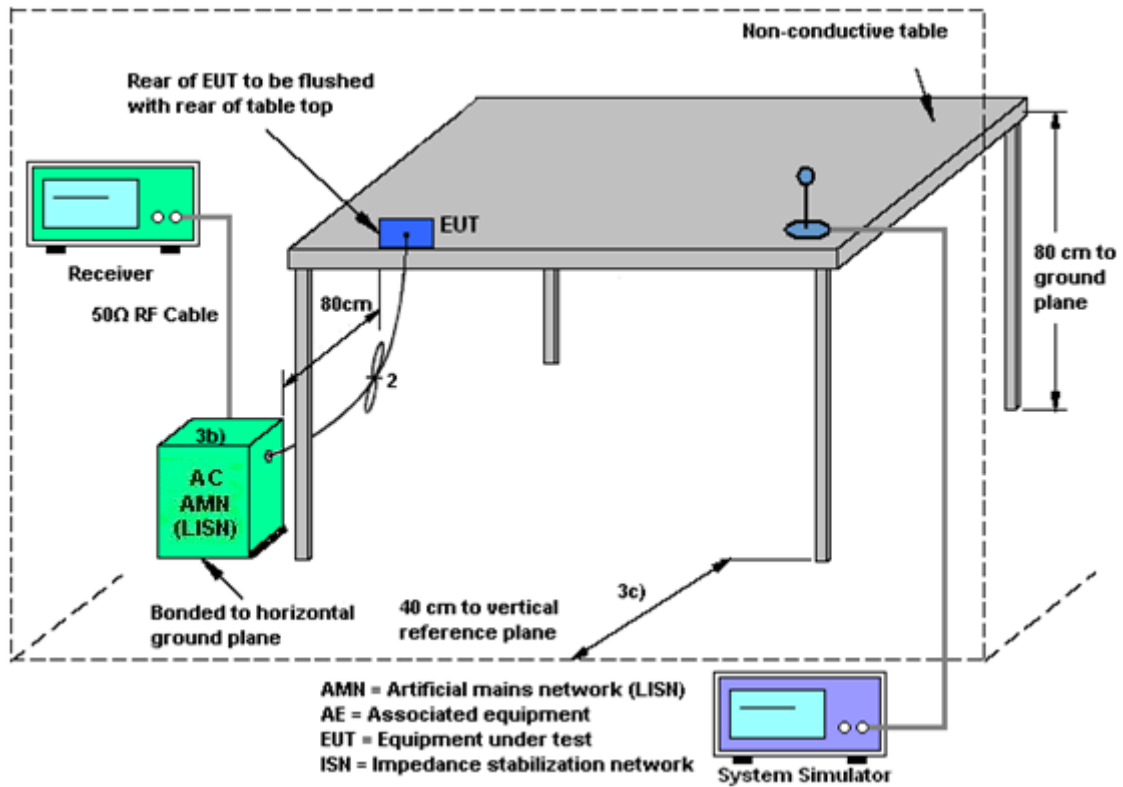

3.2.5 Test Result of AC Conducted Emission

Please refer to Appendix A.



4 List of Measuring Equipment

Instrument	Manufacturer	Model No.	Serial No.	Characteristics	Calibration Date	Test Date	Due Date	Remark
AC Power Source	ChainTek	APC-1000W	N/A	N/A	N/A	Mar. 29, 2019	N/A	Conduction (CO05-HY)
EMI Test Receiver	Rohde & Schwarz	ESR3	102388	9kHz~3.6GHz	Nov. 12, 2018	Mar. 29, 2019	Nov. 11, 2019	Conduction (CO05-HY)
LISN	Rohde & Schwarz	ENV216	100080	9kHz~30MHz	Nov. 14, 2018	Mar. 29, 2019	Nov. 13, 2019	Conduction (CO05-HY)
Software	Rohde & Schwarz	EMC32 V10.30	N/A	N/A	N/A	Mar. 29, 2019	N/A	Conduction (CO05-HY)
LF Cable	HUBER + SUHNER	RG-214/U	LF01	N/A	Dec. 31, 2018	Mar. 29, 2019	Dec. 30, 2019	Conduction (CO05-HY)
Pulse Limiter	Rohde & Schwarz	ESH3-Z2	100851	N/A	Dec. 31, 2018	Mar. 29, 2019	Dec. 30, 2019	Conduction (CO05-HY)
Amplifier	MITEQ	TTA1840-35-HG	1871923	18GHz~40GHz, VSWR : 2.5:1 max	Jul. 16, 2018	Mar. 21, 2019~ Mar. 27, 2019	Jul. 15, 2019	Radiation (03CH11-HY)
Amplifier	SONOMA	310N	187312	9kHz~1GHz	Dec. 04, 2018	Mar. 21, 2019~ Mar. 27, 2019	Dec. 03, 2019	Radiation (03CH11-HY)
Bilog Antenna	TESEQ	CBL 6111D&N-6-06	35414&AT-N0602	30MHz~1GHz	Oct. 13, 2018	Mar. 21, 2019~ Mar. 27, 2019	Oct. 12, 2019	Radiation (03CH11-HY)
Horn Antenna	SCHWARZBECK	BBHA 9120 D	9120D-1326	1GHz ~ 18GHz	Oct. 30, 2018	Mar. 21, 2019~ Mar. 27, 2019	Oct. 29, 2019	Radiation (03CH11-HY)
Loop Antenna	Rohde & Schwarz	HFH2-Z2	100488	9 kHz~30 MHz	Nov. 22, 2018	Mar. 21, 2019~ Mar. 27, 2019	Nov. 21, 2019	Radiation (03CH11-HY)
Preamplifier	Keysight	83017A	MY53270080	1GHz~26.5GHz	Nov. 14, 2018	Mar. 21, 2019~ Mar. 27, 2019	Nov. 13, 2020	Radiation (03CH11-HY)
Spectrum Analyzer	Keysight	N9010A	MY54200486	10Hz ~ 44GHz	Oct. 19, 2018	Mar. 21, 2019~ Mar. 27, 2019	Oct. 18, 2019	Radiation (03CH11-HY)
Antenna Mast	EMEC	AM-BS-4500-B	N/A	1~4m	N/A	Mar. 21, 2019~ Mar. 27, 2019	N/A	Radiation (03CH11-HY)
Turn Table	EMEC	TT 2000	N/A	0~360 Degree	N/A	Mar. 21, 2019~ Mar. 27, 2019	N/A	Radiation (03CH11-HY)
Preamplifier	Jet-Power	JPA0118-55-303K	1710001800054002	1GHz~18GHz	Apr. 17, 2018	Mar. 21, 2019~ Mar. 27, 2019	Apr. 16, 2019	Radiation (03CH11-HY)
SHF-EHF Horn Antenna	SCHWARZBECK	BBHA 9170	BBHA9170584	18GHz- 40GHz	Dec. 05, 2018	Mar. 21, 2019~ Mar. 27, 2019	Dec. 04, 2019	Radiation (03CH11-HY)
EMI Test Receiver	Keysight	N9038A(MXE)	MY53290045	N/A	Jan. 19, 2019	Mar. 21, 2019~ Mar. 27, 2019	Jan. 18, 2020	Radiation (03CH11-HY)
Software	Audix	E3 6.2009-8-24	RK-001042	N/A	N/A	Mar. 21, 2019~ Mar. 27, 2019	N/A	Radiation (03CH11-HY)
RF Cable	HUBER + SUHNER	SUCOFLEX 104	MY9837/4PE	9kHz-30MHz	Mar. 13, 2019	Mar. 21, 2019~ Mar. 27, 2019	Mar. 12, 2020	Radiation (03CH11-HY)
RF Cable	HUBER + SUHNER	SUCOFLEX 102	MY2859/2	30MHz-40GHz	Mar. 13, 2019	Mar. 21, 2019~ Mar. 27, 2019	Mar. 12, 2020	Radiation (03CH11-HY)
RF Cable	HUBER + SUHNER	SUCOFLEX 104	MY9837/4PE	30M-18G	Mar. 13, 2019	Mar. 21, 2019~ Mar. 27, 2019	Mar. 12, 2020	Radiation (03CH11-HY)
RF Cable	HUBER + SUHNER	SUCOFLEX 102	MY4274/2	30MHz-40GHz	Mar. 13, 2019	Mar. 21, 2019~ Mar. 27, 2019	Mar. 12, 2020	Radiation (03CH11-HY)
Filter	Wainwright	WHKX8-5872.5-6750-18000-40ST	SN3	6.75GHz High Pass	Sep. 17, 2018	Mar. 21, 2019~ Mar. 27, 2019	Sep. 16, 2019	Radiation (03CH11-HY)
Filter	Wainwright	WLK4-1000-1530-8000-40SS	SN11	1G Low Pass	Sep. 16, 2018	Mar. 21, 2019~ Mar. 27, 2019	Sep. 15, 2019	Radiation (03CH11-HY)
Filter	Wainwright	WHKX12-2700-3000-18000-60SS	SN3	2.7G High Pass	Sep. 16, 2018	Mar. 21, 2019~ Mar. 27, 2019	Sep. 15, 2019	Radiation (03CH11-HY)



5 Uncertainty of Evaluation

Uncertainty of Conducted Emission Measurement (150 kHz ~ 30 MHz)

Measuring Uncertainty for a Level of Confidence of 95% ($U = 2Uc(y)$)	2.2
---	-----

Uncertainty of Radiated Emission Measurement (30 MHz ~ 1000 MHz)

Measuring Uncertainty for a Level of Confidence of 95% ($U = 2Uc(y)$)	5.2
---	-----

Uncertainty of Radiated Emission Measurement (1000 MHz ~ 18000 MHz)

Measuring Uncertainty for a Level of Confidence of 95% ($U = 2Uc(y)$)	5.5
---	-----

Uncertainty of Radiated Emission Measurement (18000 MHz ~ 40000 MHz)

Measuring Uncertainty for a Level of Confidence of 95% ($U = 2Uc(y)$)	5.2
---	-----



Appendix A. AC Conducted Emission Test Results

Test Engineer : Rick Lin and Jimmy Chang	Temperature :	24~26°C
	Relative Humidity :	51~53%

EUT Information

Report NO : 930415-06
 Test Mode : Mode 2
 Test Voltage : 120Vac/60Hz
 Phase : Line

Full Spectrum

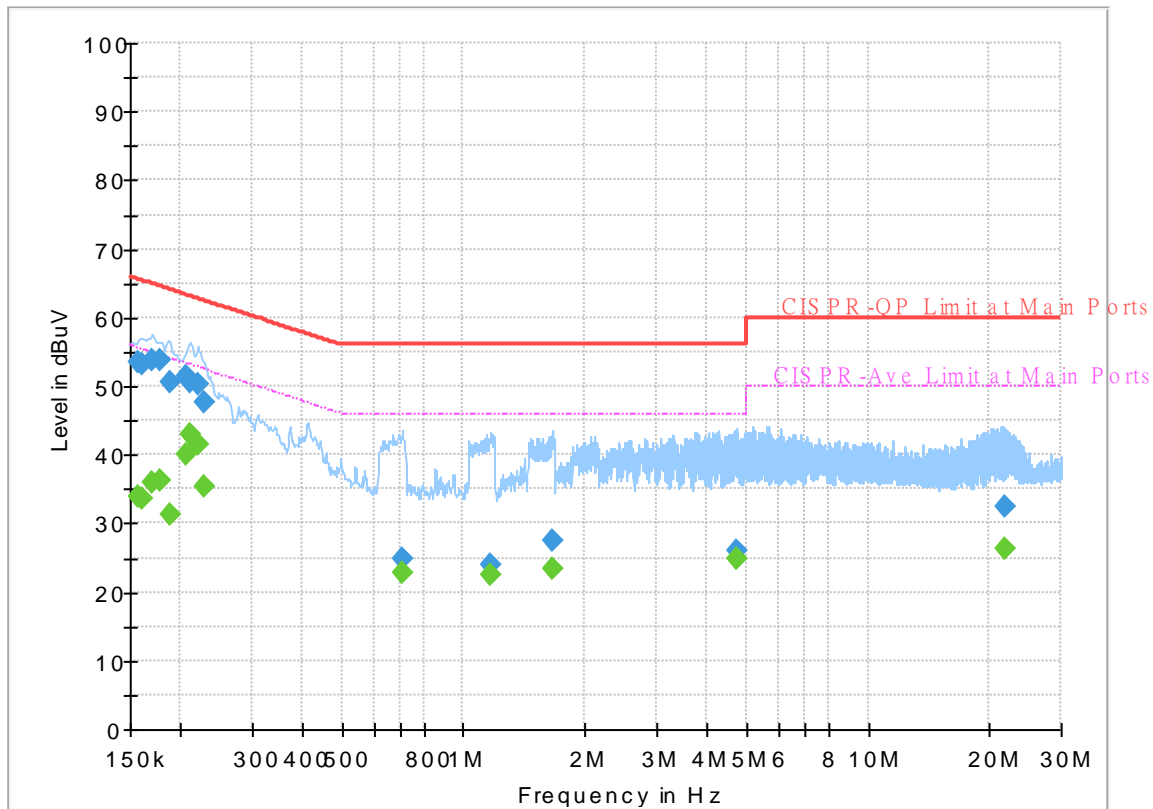

Final_Result

Frequency (MHz)	QuasiPeak (dBuV)	CAverage (dBuV)	Limit (dBuV)	Margin (dB)	Line	Filter	Corr. (dB)
0.156750	---	34.05	55.63	21.58	L1	OFF	19.5
0.156750	53.39	---	65.63	12.24	L1	OFF	19.5
0.161250	---	33.55	55.40	21.85	L1	OFF	19.5
0.161250	53.14	---	65.40	12.26	L1	OFF	19.5
0.170250	---	35.89	54.95	19.06	L1	OFF	19.5
0.170250	53.77	---	64.95	11.18	L1	OFF	19.5
0.177000	---	36.37	54.63	18.26	L1	OFF	19.5
0.177000	53.78	---	64.63	10.85	L1	OFF	19.5
0.188250	---	31.20	54.11	22.91	L1	OFF	19.5
0.188250	50.53	---	64.11	13.58	L1	OFF	19.5
0.206250	---	40.14	53.36	13.22	L1	OFF	19.5
0.206250	51.46	---	63.36	11.90	L1	OFF	19.5
0.210750	---	42.99	53.18	10.19	L1	OFF	19.5
0.210750	50.47	---	63.18	12.71	L1	OFF	19.5
0.219750	---	41.46	52.83	11.37	L1	OFF	19.5
0.219750	50.30	---	62.83	12.53	L1	OFF	19.5
0.228750	---	35.43	52.50	17.07	L1	OFF	19.5
0.228750	47.62	---	62.50	14.88	L1	OFF	19.5
0.705750	---	22.82	46.00	23.18	L1	OFF	19.6
0.705750	24.91	---	56.00	31.09	L1	OFF	19.6
1.164750	---	22.63	46.00	23.37	L1	OFF	19.6

1.164750	24.00	---	56.00	32.00	L1	OFF	19.6
1.662000	---	23.53	46.00	22.47	L1	OFF	19.6
1.662000	27.43	---	56.00	28.57	L1	OFF	19.6
4.724250	---	24.91	46.00	21.09	L1	OFF	19.7
4.724250	25.97	---	56.00	30.03	L1	OFF	19.7
21.864750	---	26.44	50.00	23.56	L1	OFF	20.3
21.864750	32.58	---	60.00	27.42	L1	OFF	20.3

EUT Information

Report NO : 930415-06
 Test Mode : Mode 2
 Test Voltage : 120Vac/60Hz
 Phase : Neutral

Full Spectrum

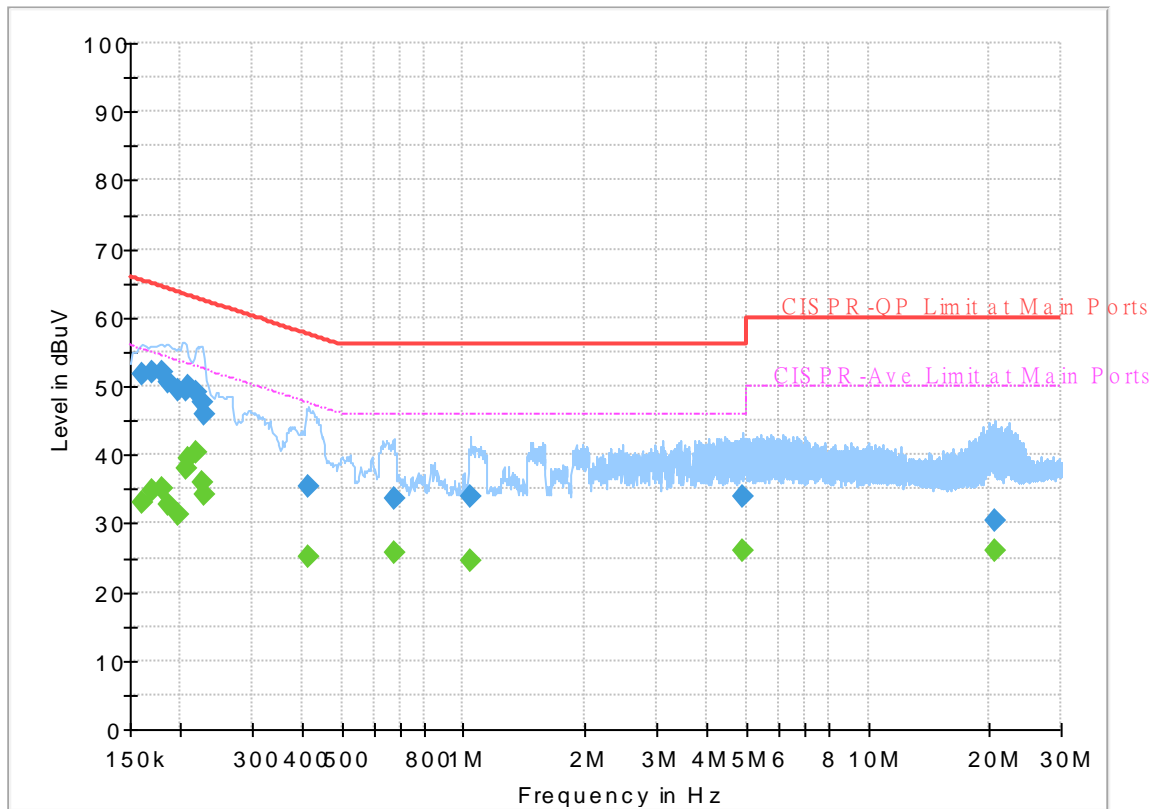

Final_Result

Frequency (MHz)	QuasiPeak (dBuV)	CAverage (dBuV)	Limit (dBuV)	Margin (dB)	Line	Filter	Corr. (dB)
0.161250	51.78	---	65.40	13.62	N	OFF	19.5
0.161250	---	32.95	55.40	22.45	N	OFF	19.5
0.170250	52.03	---	64.95	12.92	N	OFF	19.5
0.170250	---	34.78	54.95	20.17	N	OFF	19.5
0.179250	52.02	---	64.52	12.50	N	OFF	19.5
0.179250	---	34.95	54.52	19.57	N	OFF	19.5
0.186000	50.62	---	64.21	13.59	N	OFF	19.5
0.186000	---	32.64	54.21	21.57	N	OFF	19.5
0.197250	49.49	---	63.73	14.24	N	OFF	19.5
0.197250	---	31.20	53.73	22.53	N	OFF	19.5
0.206250	49.47	---	63.36	13.89	N	OFF	19.5
0.206250	---	38.07	53.36	15.29	N	OFF	19.5
0.208500	50.03	---	63.27	13.24	N	OFF	19.5
0.208500	---	39.48	53.27	13.79	N	OFF	19.5
0.217500	49.20	---	62.91	13.71	N	OFF	19.5
0.217500	---	40.45	52.91	12.46	N	OFF	19.5
0.226500	47.67	---	62.58	14.91	N	OFF	19.5
0.226500	---	35.85	52.58	16.73	N	OFF	19.5
0.228750	45.78	---	62.50	16.72	N	OFF	19.5
0.228750	---	34.18	52.50	18.32	N	OFF	19.5
0.415500	35.42	---	57.54	22.12	N	OFF	19.5

0.415500	---	25.19	47.54	22.35	N	OFF	19.5
0.674250	33.48	---	56.00	22.52	N	OFF	19.6
0.674250	---	25.71	46.00	20.29	N	OFF	19.6
1.043250	33.78	---	56.00	22.22	N	OFF	19.6
1.043250	---	24.68	46.00	21.32	N	OFF	19.6
4.884000	34.04	---	56.00	21.96	N	OFF	19.7
4.884000	---	26.01	46.00	19.99	N	OFF	19.7
20.586750	30.54	---	60.00	29.46	N	OFF	20.3
20.586750	---	26.09	50.00	23.91	N	OFF	20.3



Appendix B. Radiated Spurious Emission

Test Engineer :	Hao Shu and Ken Wu	Temperature :	21~26°C
		Relative Humidity :	50~56%

<WPC Charging Mode>

2.4GHz 2400~2483.5MHz

BLE_1Mbps (Band Edge @ 3m)

BLE	Note	Frequency (MHz)	Level (dBμV/m)	Over Limit (dB)	Limit Line (dBμV/m)	Read Level (dBμV)	Antenna Factor (dB/m)	Path Loss (dB)	Preamp Factor (dB)	Ant Pos (cm)	Table Pos (deg)	Peak Avg. (P/A)	Pol. (H/V)
BLE CH 39 2480MHz	*	2480	97.4	-	-	86.97	27.3	16.73	33.6	105	124	P	H
	*	2480	96.28	-	-	85.85	27.3	16.73	33.6	105	124	A	H
		2499.76	52.73	-21.27	74	42.27	27.3	16.75	33.59	105	124	P	H
		2487.24	43.63	-10.37	54	33.18	27.3	16.74	33.59	105	124	A	H
													H
													H
	*	2480	97.13	-	-	86.7	27.3	16.73	33.6	139	311	P	V
	*	2480	96.56	-	-	86.13	27.3	16.73	33.6	139	311	A	V
		2497.76	52.81	-21.19	74	42.35	27.3	16.75	33.59	139	311	P	V
		2498	43.59	-10.41	54	33.13	27.3	16.75	33.59	139	311	A	V
													V
													V
Remark	1. No other spurious found. 2. All results are PASS against Peak and Average limit line.												



2.4GHz 2400~2483.5MHz
BLE_1Mbps (Harmonic @ 3m)

BLE	Note	Frequency (MHz)	Level (dBμV/m)	Over Limit (dB)	Limit Line (dBμV/m)	Read Level (dBμV)	Antenna Factor (dB/m)	Path Loss (dB)	Preamp Factor (dB)	Ant Pos (cm)	Table Pos (deg)	Peak Avg. (P/A)	Pol. (H/V)
BLE CH 39 2480MHz		4960	39.27	-34.73	74	55.78	31.32	10.68	58.51	100	0	P	H
		7440	43.62	-30.38	74	52.72	36.48	13.08	58.66	100	0	P	H
													H
													H
		4960	39.53	-34.47	74	56.04	31.32	10.68	58.51	100	0	P	V
		7440	43.76	-30.24	74	52.86	36.48	13.08	58.66	100	0	P	V
													V
													V
Remark	1. No other spurious found. 2. All results are PASS against Peak and Average limit line.												



Emission below 1GHz
2.4GHz BLE_1Mbps (LF)

BLE	Note	Frequency	Level	Over	Limit	Read	Antenna	Path	Preamp	Ant	Table	Peak	Pol.	
		(MHz)	(dBμV/m)	(dB)	(dBμV/m)	(dBμV)	(dB/m)	(dB)	(dB)	(cm)	(deg)	(P/A)	(H/V)	
2.4GHz BLE LF		94.02	21.78	-21.72	43.5	37.75	15.04	1.32	32.33	-	-	P	H	
		177.44	23.33	-20.17	43.5	38.78	14.93	1.88	32.26	-	-	P	H	
		302.57	28.88	-17.12	46	39.58	19.1	2.38	32.18	-	-	P	H	
		498.51	25.24	-20.76	46	30.67	23.72	3.01	32.16	-	-	P	H	
		746.83	30.41	-15.59	46	30.84	27.77	3.81	32.01	-	-	P	H	
		940.83	33.58	-12.42	46	30.26	30	4.29	30.97	100	0	P	H	
													H	
													H	
													H	
													H	
													H	
													H	
			45.52	31.76	-8.24	40	46.91	16.32	0.9	32.37	100	0	P	V
			63.95	26.03	-13.97	40	45.69	11.61	1.09	32.36	-	-	P	V
			196.84	32.78	-10.72	43.5	48.28	14.8	1.94	32.24	-	-	P	V
			439.34	23.9	-22.1	46	30.42	22.8	2.84	32.16	-	-	P	V
			715.79	28.95	-17.05	46	30.45	26.91	3.68	32.09	-	-	P	V
			951.5	33.5	-12.5	46	29.43	30.64	4.31	30.88	-	-	P	V
														V
														V
													V	
													V	
													V	
													V	
Remark	1. No other spurious found. 2. All results are PASS against limit line.													



<PMA Charging Mode>

2.4GHz 2400~2483.5MHz

BLE_1Mbps (Band Edge @ 3m)

BLE	Note	Frequency (MHz)	Level (dBμV/m)	Over Limit (dB)	Limit Line (dBμV/m)	Read Level (dBμV)	Antenna Factor (dB/m)	Path Loss (dB)	Preamp Factor (dB)	Ant Pos (cm)	Table Pos (deg)	Peak Avg. (P/A)	Pol. (H/V)
BLE CH 39 2480MHz	*	2480	97.48	-	-	87.05	27.3	16.73	33.6	109	287	P	H
	*	2480	96.9	-	-	86.47	27.3	16.73	33.6	109	287	A	H
		2498.44	51.97	-22.03	74	41.51	27.3	16.75	33.59	109	287	P	H
		2498.96	43.32	-10.68	54	32.86	27.3	16.75	33.59	109	287	A	H
													H
													H
	*	2480	94.77	-	-	84.34	27.3	16.73	33.6	373	99	P	V
	*	2480	94.06	-	-	83.63	27.3	16.73	33.6	373	99	A	V
		2488.92	53.65	-20.35	74	43.2	27.3	16.74	33.59	373	99	P	V
		2498.76	43.33	-10.67	54	32.87	27.3	16.75	33.59	373	99	A	V
													V
													V
Remark	1. No other spurious found. 2. All results are PASS against Peak and Average limit line.												



2.4GHz 2400~2483.5MHz
BLE_1Mbps (Harmonic @ 3m)

BLE	Note	Frequency (MHz)	Level (dBμV/m)	Over Limit (dB)	Limit Line (dBμV/m)	Read Level (dBμV)	Antenna Factor (dB/m)	Path Loss (dB)	Preamp Factor (dB)	Ant Pos (cm)	Table Pos (deg)	Peak Avg. (P/A)	Pol. (H/V)
BLE CH 39 2480MHz		4960	39.35	-34.65	74	55.86	31.32	10.68	58.51	100	0	P	H
		7440	43.58	-30.42	74	52.68	36.48	13.08	58.66	100	0	P	H
													H
													H
		4960	39.64	-34.36	74	56.15	31.32	10.68	58.51	100	0	P	V
		7440	43.81	-30.19	74	52.91	36.48	13.08	58.66	100	0	P	V
													V
													V
Remark	1. No other spurious found. 2. All results are PASS against Peak and Average limit line.												



Emission below 1GHz
2.4GHz BLE_1Mbps (LF)

BLE	Note	Frequency	Level	Over	Limit	Read	Antenna	Path	Preamp	Ant	Table	Peak	Pol.	
		(MHz)	(dBμV/m)	(dB)	(dBμV/m)	(dBμV)	(dB/m)	(dB)	(dB)	(cm)	(deg)	(P/A)	(H/V)	
2.4GHz BLE LF		164.83	25.14	-18.36	43.5	39.8	15.82	1.79	32.27	-	-	P	H	
		196.84	31.5	-12	43.5	47	14.8	1.94	32.24	100	0	P	H	
		206.54	29.72	-13.78	43.5	45.08	14.9	1.98	32.24	-	-	P	H	
		348.16	32.76	-13.24	46	42.27	20.13	2.53	32.17	-	-	P	H	
		560.59	27.17	-18.83	46	30.05	26.07	3.24	32.19	-	-	P	H	
		945.68	33.45	-12.55	46	29.77	30.31	4.3	30.93	-	-	P	H	
														H
														H
														H
														H
														H
														H
			45.52	33.94	-6.06	40	49.09	16.32	0.9	32.37	100	0	P	V
			148.34	34.86	-8.64	43.5	48.55	16.95	1.64	32.28	-	-	P	V
			273.47	26.64	-19.36	46	37.8	18.78	2.26	32.2	-	-	P	V
			343.31	27.26	-18.74	46	36.93	19.99	2.51	32.17	-	-	P	V
			621.7	27.05	-18.95	46	30.03	25.8	3.41	32.19	-	-	P	V
			919.49	32.3	-13.7	46	30.12	29.11	4.24	31.17	-	-	P	V
														V
														V
													V	
													V	
													V	
													V	
Remark	3. No other spurious found. 4. All results are PASS against limit line.													



Note symbol

*	Fundamental Frequency which can be ignored. However, the level of any unwanted emissions shall not exceed the level of the fundamental frequency.
!	Test result is over limit line.
P/A	Peak or Average
H/V	Horizontal or Vertical



A calculation example for radiated spurious emission is shown as below:

BLE	Note	Frequency	Level	Over	Limit	Read	Antenna	Path	Preamp	Ant	Table	Peak	Pol.
		(MHz)	(dBμV/m)	(dB)	(dBμV/m)	(dBμV)	(dB/m)	(dB)	(dB)	(cm)	(deg)	(P/A)	(H/V)
BLE CH 00 2402MHz		2390	55.45	-18.55	74	54.51	32.22	4.58	35.86	103	308	P	H
		2390	43.54	-10.46	54	42.6	32.22	4.58	35.86	103	308	A	H

1. Path Loss(dB) = Cable loss(dB) + Filter loss(dB) + Attenuator loss(dB)
2. Level(dBμV/m) =
Antenna Factor(dB/m) + Path Loss(dB) + Read Level(dBμV) - Preamp Factor(dB)
3. Over Limit(dB) = Level(dBμV/m) – Limit Line(dBμV/m)

For Peak Limit @ 2390MHz:

1. Level(dBμV/m)
= Antenna Factor(dB/m) + Path Loss(dB) + Read Level(dBμV) - Preamp Factor(dB)
= 32.22(dB/m) + 4.58(dB) + 54.51(dBμV) – 35.86 (dB)
= 55.45 (dBμV/m)
2. Over Limit(dB)
= Level(dBμV/m) – Limit Line(dBμV/m)
= 55.45(dBμV/m) – 74(dBμV/m)
= -18.55(dB)

For Average Limit @ 2390MHz:

1. Level(dBμV/m)
= Antenna Factor(dB/m) + Path Loss(dB) + Read Level(dBμV) - Preamp Factor(dB)
= 32.22(dB/m) + 4.58(dB) + 42.6(dBμV) – 35.86 (dB)
= 43.54 (dBμV/m)
2. Over Limit(dB)
= Level(dBμV/m) – Limit Line(dBμV/m)
= 43.54(dBμV/m) – 54(dBμV/m)
= -10.46(dB)

Both peak and average measured complies with the limit line, so test result is “PASS”.



Appendix C. Radiated Spurious Emission Plots

Test Engineer :	Hao Shu, and Ken Wu	Temperature :	21~26°C
		Relative Humidity :	50~56%

<WPC Charging Mode>
2.4GHz 2400~2483.5MHz
BLE_1Mbps (Band Edge @ 3m)

BLE	2.4GHz 2400~2483.5MHz Band Edge @ 3m	
	BLE_1Mbps CH39 2480MHz	
	Horizontal	Fundamental
Peak	<p> Site : 03CH11-HY Condition : PEAK_BE_74 3m HORN 91200-HF HORIZONTAL Detector : RBW:1000.000kHz VBW:3000.000kHz SWT:Auto Project : 930415-06 </p>	<p> Site : 03CH11-HY Condition : PEAK_74 3m HORN 91200-HF HORIZONTAL Detector : RBW:1000.000kHz VBW:3000.000kHz SWT:Auto Project : 930415-06 </p>
Avg.	<p> Site : 03CH11-HY Condition : AVG_BE_54 3m HORN 91200-HF HORIZONTAL Detector : RBW:1000.000kHz VBW:3.000kHz SWT:Auto Project : 930415-06 </p>	<p> Site : 03CH11-HY Condition : AVG_54 3m HORN 91200-HF HORIZONTAL Detector : RBW:1000.000kHz VBW:3.000kHz SWT:Auto Project : 930415-06 </p>

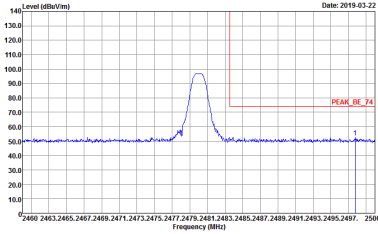
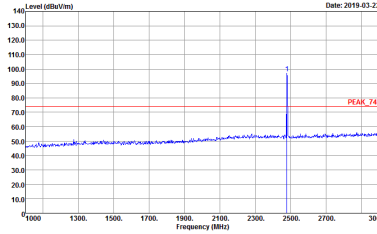
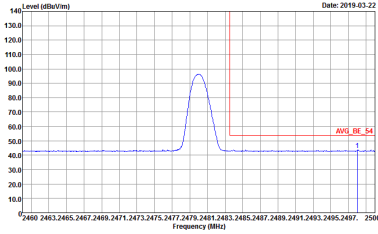
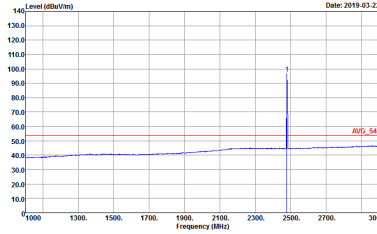

BLE	2.4GHz 2400~2483.5MHz Band Edge @ 3m	
BLE_1Mbps CH39 2480MHz		
	Vertical	Fundamental
Peak	 <p>Site : 03CH11-HY Condition : PEAK_BE_74 3m HORN 91200-HF VERTICAL RBW:1000.000KHz VBW:3000.000KHz SWT:Auto Detector : Peak Project : 930415-06</p>	 <p>Site : 03CH11-HY Condition : PEAK_74 3m HORN 91200-HF VERTICAL RBW:1000.000KHz VBW:3000.000KHz SWT:Auto Detector : Peak Project : 930415-06</p>
Avg.	 <p>Site : 03CH11-HY Condition : AVG_BE_54 3m HORN 91200-HF VERTICAL RBW:1000.000KHz VBW:3.000KHz SWT:Auto Detector : Peak Project : 930415-06</p>	 <p>Site : 03CH11-HY Condition : AVG_54 3m HORN 91200-HF VERTICAL RBW:1000.000KHz VBW:3.000KHz SWT:Auto Detector : Peak Project : 930415-06</p>

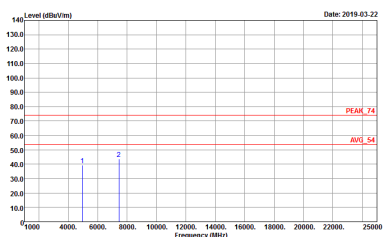
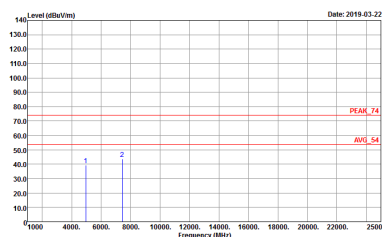

2.4GHz 2400~2483.5MHz
BLE_1Mbps (Harmonic @ 3m)

BLE	2.4GHz 2400~2483.5MHz Harmonic @ 3m	
BLE_1Mbps CH39 2480MHz		
	Horizontal	Vertical
Peak	 <p>Site : 03CH11-HF Condition : PEAK_74 3m HORN 91200-HF HORIZONTAL Detector : Peak Project : 930415-06</p>	 <p>Site : 03CH11-HF Condition : PEAK_74 3m HORN 91200-HF VERTICAL Detector : Peak Project : 930415-06</p>

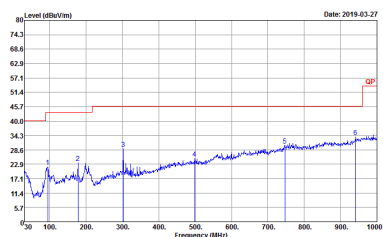
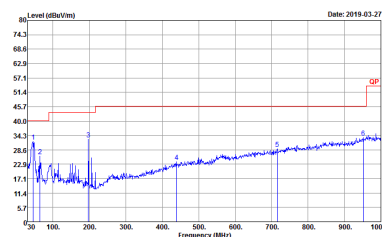

Emission below 1GHz
2.4GHz BLE_1Mbps (LF)

BLE	2.4GHz 2400~2483.5MHz	
	BLE_1Mbps LF	
	Horizontal	Vertical
QP / Peak	 <p data-bbox="430 779 686 828">Site : 03CH11-4FY Condition : QP_3m BT-LOG 6111D-LF_ETC HORIZONTAL Detector : Peak Project : 930415-06</p>	 <p data-bbox="901 779 1157 828">Site : 03CH11-4FY Condition : QP_3m BT-LOG 6111D-LF_ETC VERTICAL Detector : Peak Project : 930415-06</p>

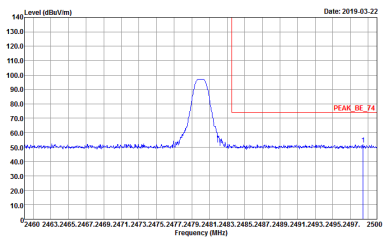
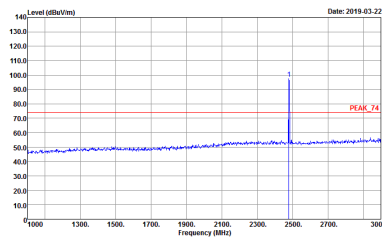
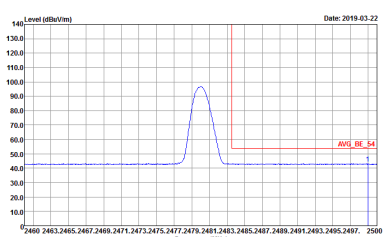
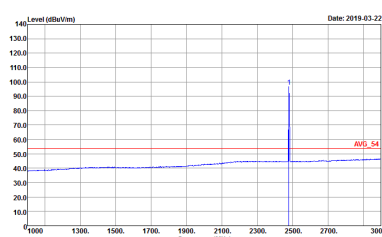

<PMA Charging Mode>
2.4GHz 2400~2483.5MHz
BLE_1Mbps (Band Edge @ 3m)

BLE	2.4GHz 2400~2483.5MHz Band Edge @ 3m	
	BLE_1Mbps CH39 2480MHz	
	Horizontal	Fundamental
<p align="center">Peak</p>	 <p> Date: 2019-03-22 Site : 03CH11-HY Condition : PEAK_BE_74 3m HORN 91200-HF HORIZONTAL Detector : Peak Project : 930415-06 </p>	 <p> Date: 2019-03-22 Site : 03CH11-HY Condition : PEAK_74 3m HORN 91200-HF HORIZONTAL Detector : Peak Project : 930415-06 </p>
<p align="center">Avg.</p>	 <p> Date: 2019-03-22 Site : 03CH11-HY Condition : AVG_BE_54 3m HORN 91200-HF HORIZONTAL Detector : Peak Project : 930415-06 </p>	 <p> Date: 2019-03-22 Site : 03CH11-HY Condition : AVG_54 3m HORN 91200-HF HORIZONTAL Detector : Peak Project : 930415-06 </p>

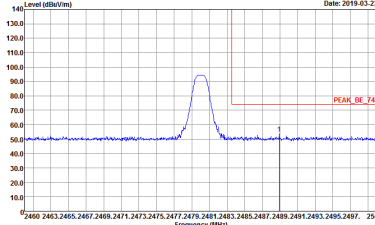
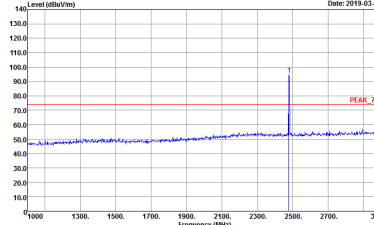
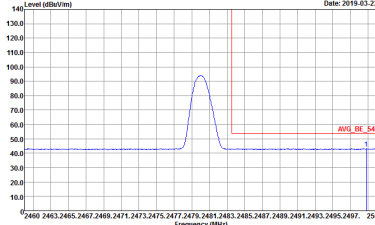
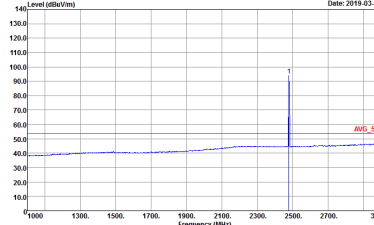

BLE	2.4GHz 2400~2483.5MHz Band Edge @ 3m	
BLE_1Mbps CH39 2480MHz		
	Vertical	Fundamental
Peak	 <p>Site : 03CH11-HY Condition : PEAK_BE_74 3m HORN 91200-HF VERTICAL RBW:1000.000kHz VBW:3000.000kHz SWT:Auto Detector : Peak Project : 930415-06</p>	 <p>Site : 03CH11-HY Condition : PEAK_74 3m HORN 91200-HF VERTICAL RBW:1000.000kHz VBW:3000.000kHz SWT:Auto Detector : Peak Project : 930415-06</p>
Avg.	 <p>Site : 03CH11-HY Condition : AVG_BE_54 3m HORN 91200-HF VERTICAL RBW:1000.000kHz VBW:3.000kHz SWT:Auto Detector : Peak Project : 930415-06</p>	 <p>Site : 03CH11-HY Condition : AVG_54 3m HORN 91200-HF VERTICAL RBW:1000.000kHz VBW:3.000kHz SWT:Auto Detector : Peak Project : 930415-06</p>



2.4GHz 2400~2483.5MHz

BLE_1Mbps (Harmonic @ 3m)

BLE	2.4GHz 2400~2483.5MHz Harmonic @ 3m	
	BLE_1Mbps CH39 2480MHz	
	Horizontal	Vertical
Peak	<p>Site : 03CH11-HF Condition : PEAK_74 3m HORN 91200-HF HORIZONTAL Detector : Peak Project : 930415-06</p>	<p>Site : 03CH11-HF Condition : PEAK_74 3m HORN 91200-HF VERTICAL Detector : Peak Project : 930415-06</p>



Emission below 1GHz
2.4GHz BLE_1Mbps (LF)

BLE	2.4GHz 2400~2483.5MHz	
	BLE_1Mbps (LF)	
	Horizontal	Vertical
QP / Peak	<p>Site : 03CH11-HY Condition : QP_3m BT-LOG 6111D-LF_ETC HORIZONTAL Detector : Peak Project : 930415-06</p>	<p>Site : 03CH11-HY Condition : QP_3m BT-LOG 6111D-LF_ETC VERTICAL Detector : Peak Project : 930415-06</p>

Appendix D. Duty Cycle Plots

Band	Duty Cycle (%)	T(us)	1/T(kHz)	VBW Setting	Duty Factor (dB)
Bluetooth –LE for 1Mbps	62.30	390.00	2.56	3kHz	2.06

Bluetooth – LE

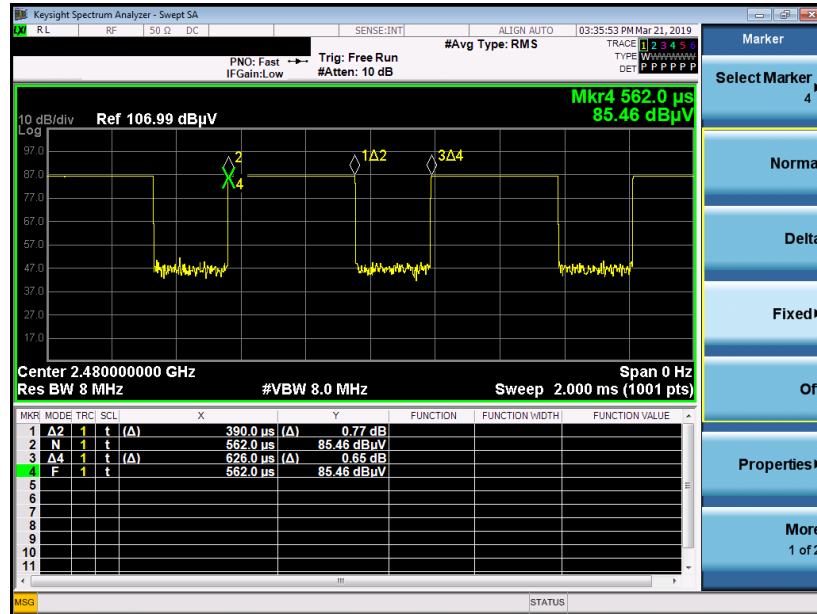

————THE END————