



# FCC RADIO TEST REPORT

**FCC ID** : IHDT56XS1  
**Equipment** : Mobile Cellular Phone  
**Brand Name** : Motorola  
**Model Name** : XT1980-4  
**Applicant** : Motorola Mobility LLC  
222 W, Merchandise Mart Plaza, Chicago IL 60654 USA  
**Manufacturer** : Motorola Mobility LLC  
222 W, Merchandise Mart Plaza, Chicago IL 60654 USA  
**Standard** : FCC Part 15 Subpart E §15.407

The product was received on Mar. 05, 2019 and testing was started from Mar. 21, 2019 and completed on Mar. 29, 2019. We, SPORTON INTERNATIONAL INC. EMC & Wireless Communications Laboratory, would like to declare that the tested sample has been evaluated in accordance with the test procedures and has been in compliance with the applicable technical standards.

The report must not be used by the client to claim product certification, approval, or endorsement by TAF or any agency of government.

The test results in this partial report apply exclusively to the tested model / sample. Without written approval of SPORTON INTERNATIONAL INC. EMC & Wireless Communications Laboratory, the test report shall not be reproduced except in full.

Approved by: Jones Tsai

**SPORTON INTERNATIONAL INC. EMC & Wireless Communications Laboratory**  
No. 52, Huaya 1st Rd., Guishan Dist., Taoyuan City, Taiwan (R.O.C.)



## Table of Contents

History of this test report.....	3
Summary of Test Result.....	4
<b>1 General Description .....</b>	<b>5</b>
1.1 Product Feature of Equipment Under Test.....	5
1.2 Product Specification of Equipment Under Test.....	5
1.3 Modification of EUT .....	5
1.4 Testing Location .....	6
1.5 Applicable Standards.....	6
<b>2 Test Configuration of Equipment Under Test .....</b>	<b>7</b>
2.1 Carrier Frequency and Channel .....	7
2.2 Test Mode.....	8
2.3 Connection Diagram of Test System.....	8
2.4 Support Unit used in test configuration and system .....	10
2.5 EUT Operation Test Setup .....	10
<b>3 Test Result .....</b>	<b>11</b>
3.1 Unwanted Emissions Measurement.....	11
3.2 AC Conducted Emission Measurement.....	16
<b>4 List of Measuring Equipment.....</b>	<b>18</b>
<b>5 Uncertainty of Evaluation .....</b>	<b>19</b>
<b>Appendix A. AC Conducted Emission Test Result</b>	
<b>Appendix B. Radiated Spurious Emission</b>	
<b>Appendix C. Radiated Spurious Emission Plots</b>	
<b>Appendix D. Duty Cycle Plots</b>	



### History of this test report

Report No.	Version	Description	Issued Date
FR930415-06E	01	Initial issue of report	Apr. 19, 2019



### Summary of Test Result

Report Clause	Ref Std. Clause	Test Items	Result (PASS/FAIL)	Remark
3.1	15.407(b)	Unwanted Emissions	Pass	Under limit 7.14 dB at 45.520 MHz
3.2	15.207	AC Conducted Emission	Pass	Under limit 9.03 dB at 0.213 MHz

**Declaration of Conformity:**

The test results with all measurement uncertainty excluded are presented in accordance with the regulation limits or requirements declared by manufacturers.

**Comments and Explanations:**

The declared of product specification for EUT presented in the report are provided by the manufacturer, and the manufacturer takes all the responsibilities for the accuracy of product specification.

**Reviewed by: Wii Chang**

**Report Producer: Natasha Hsieh**



# 1 General Description

## 1.1 Product Feature of Equipment Under Test

Product Feature	
Equipment	Mobile Cellular Phone
Brand Name	Motorola
Model Name	XT1980-4
FCC ID	IHDT56XS1
IMEI Code	Conduction : 352157100011156 Radiation : 352157100011040
EUT supports Radios application	CDMA/EV-DO/GSM/EGPRS/WCDMA/HSPA/LTE/GNSS/NFC/FM/WPC WLAN 11a/b/g/n HT20/HT40 WLAN 11ac VHT20/VHT40/VHT80 Bluetooth BR/EDR/LE
HW Version	DVT2
EUT Stage	Identical Prototype

Remark: The above EUT's information was declared by manufacturer.

Accessory List	
WPC Cover	Brand Name : Motorola
	Model Name : MD100W

## 1.2 Product Specification of Equipment Under Test

Standards-related Product Specification	
Tx/Rx Frequency Range	5180 MHz ~ 5240 MHz 5260 MHz ~ 5320 MHz 5500 MHz ~ 5700 MHz
Antenna Type / Gain	<5150 MHz ~ 5250 MHz> Loop Antenna with gain -8.0 dBi <5250 MHz ~ 5350 MHz> Loop Antenna with gain -8.0 dBi <5470 MHz ~ 5725 MHz> Loop Antenna with gain -8.0 dBi
Type of Modulation	802.11a/n : OFDM (BPSK / QPSK / 16QAM / 64QAM) 802.11ac: OFDM (BPSK / QPSK / 16QAM / 64QAM / 256QAM)

Note: The WLAN operation in 5600 MHz ~ 5650 MHz is notched.

## 1.3 Modification of EUT

No modifications are made to the EUT during all test items.



### 1.4 Testing Location

<b>Test Site</b>	SPORTON INTERNATIONAL INC.
<b>Test Site Location</b>	No.52, Huaya 1st Rd., Guishan Dist., Taoyuan City, Taiwan (R.O.C.) TEL: +886-3-327-3456 FAX: +886-3-328-4978
<b>Test Site No.</b>	<b>Sporton Site No.</b>
	CO05-HY

**Note:** The test site complies with ANSI C63.4 2014 requirement.

<b>Test Site</b>	SPORTON INTERNATIONAL INC.
<b>Test Site Location</b>	No.58, Aly. 75, Ln. 564, Wenhua 3rd, Rd., Guishan Dist., Taoyuan City, Taiwan (R.O.C.) TEL: +886-3-327-0868 FAX: +886-3-327-0855
<b>Test Site No.</b>	<b>Sporton Site No.</b>
	03CH11-HY

**Note:** The test site complies with ANSI C63.4 2014 requirement.

FCC Designation No. TW1190 and TW0007

### 1.5 Applicable Standards

According to the specifications of the manufacturer, the EUT must comply with the requirements of the following standards:

- ♦ FCC Part 15 Subpart E
- ♦ FCC KDB 789033 D02 General UNII Test Procedures New Rules v02r01.
- ♦ FCC KDB 414788 D01 Radiated Test Site v01r01.
- ♦ ANSI C63.10-2013

**Remark:**

1. All test items were verified and recorded according to the standards and without any deviation during the test.
2. This EUT has also been tested and complied with the requirements of FCC Part 15, Subpart B, recorded in a separate test report.



## 2 Test Configuration of Equipment Under Test

- a. The EUT has been associated with peripherals and configuration operated in a manner tended to maximize its emission characteristics in a typical application. Frequency range investigated: conduction emission (150 kHz to 30 MHz), radiation emission (9 kHz to the 10th harmonic of the highest fundamental frequency or to 40 GHz, whichever is lower).
- b. AC power line Conducted Emission was tested under maximum output power.

### 2.1 Carrier Frequency and Channel

Frequency Band	Channel	Freq. (MHz)	Channel	Freq. (MHz)
5150-5250 MHz Band 1 (U-NII-1)	36	5180	44	5220
	38*	5190	46*	5230
	40	5200	48	5240
	42 <sup>#</sup>	5210		

Frequency Band	Channel	Freq. (MHz)	Channel	Freq. (MHz)
5250-5350 MHz Band 2 (U-NII-2A)	52	5260	60	5300
	54*	5270	62*	5310
	56	5280	64	5320
	58 <sup>#</sup>	5290		

Frequency Band	Channel	Freq. (MHz)	Channel	Freq. (MHz)
5470-5725 MHz Band 3 (U-NII-2C)	100	5500	112	5560
	102*	5510	116	5580
	104	5520	132	5660
	106 <sup>#</sup>	5530	134*	5670
	108	5540	136	5680
	110*	5550	140	5700

**Note:**

1. The above Frequency and Channel in "\*" were 802.11n HT40 and 802.11ac VHT40.
2. The above Frequency and Channel in "<sup>#</sup>" were 802.11ac VHT80.

## 2.2 Test Mode

Final test modes are considering the modulation and worse data rates as below table.

Modulation	Data Rate
802.11a	6 Mbps

Test Cases	
AC Conducted Emission	Mode 1 : GSM1900 Idle + Bluetooth Link + WLAN Link + Camera + Battery + WPC Back Cover + LG Charging Pad + USB Cable (Charging from Adapter) + SIM 1
	Mode 2 : WCDMA Band V Idle + Bluetooth Link + WLAN Link + MPEG4 + Battery + WPC Back Cover + PMA Charging Pad + Adapter + SIM 1

**Remark:**

1. The worst case of conducted emission is mode 2; only the test data of it was reported.
2. For radiation emission, the tests were performed with WPC Back Cover+ LG Charging Pad.

Ch. #		Band III : 5470-5725MHz
		802.11a
H	High	140

## 2.3 Connection Diagram of Test System

<WLAN Tx with LG Charging Mode>

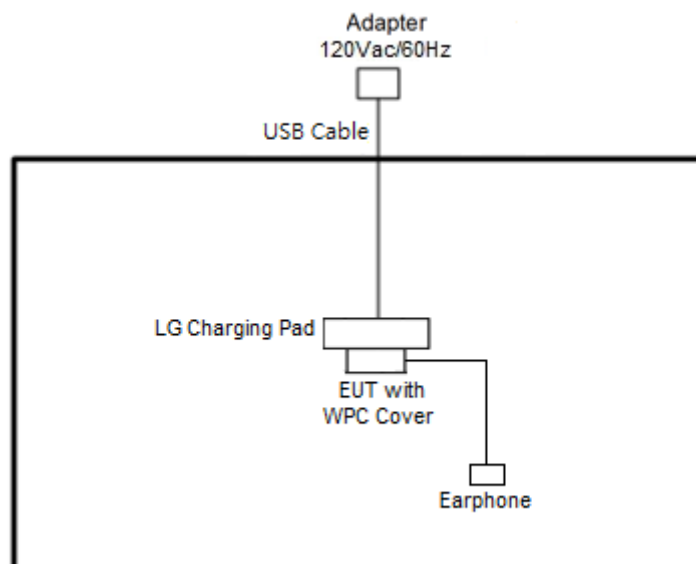



<AC Conducted Emission with WPC Charging Mode>

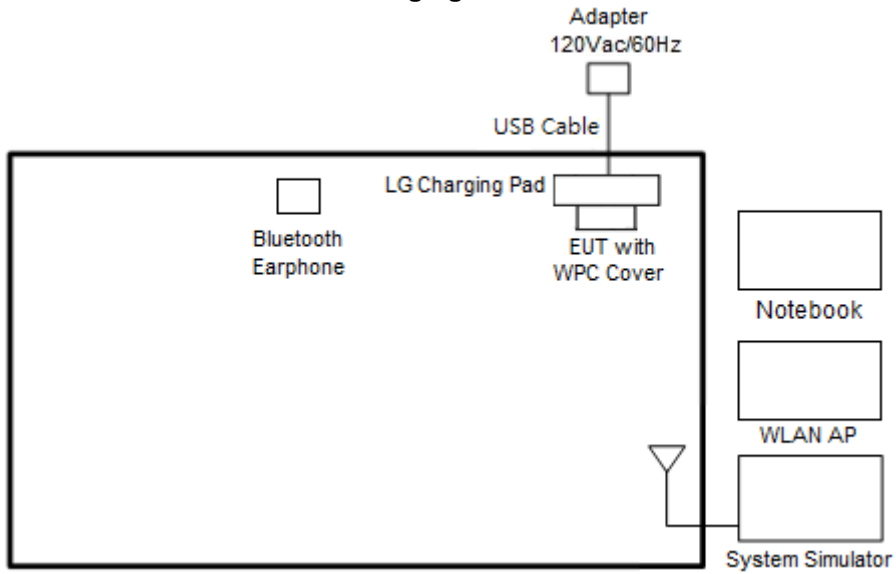

<AC Conducted Emissions with PMA Charging Mode>

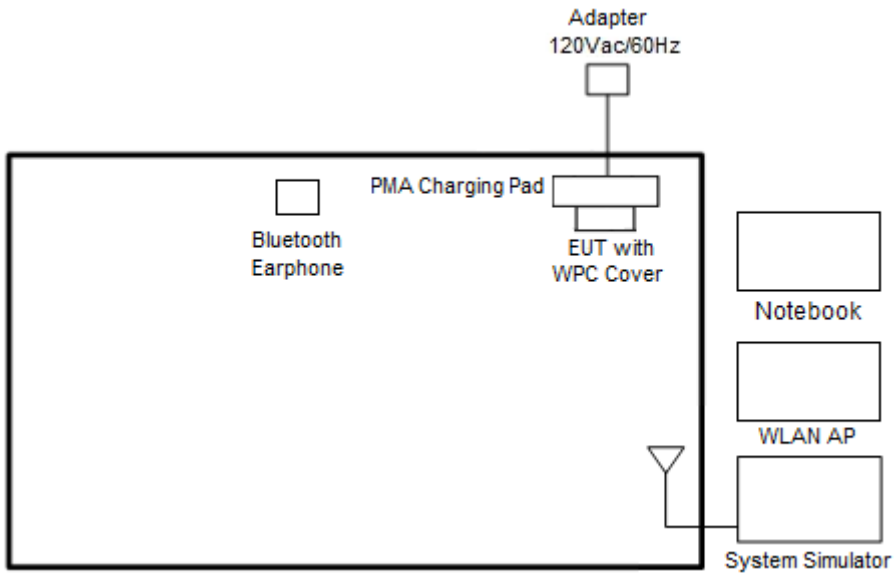



## 2.4 Support Unit used in test configuration and system

Item	Equipment	Trade Name	Model Name	FCC ID	Data Cable	Power Cord
1.	System Simulator	Anritsu	MT8820C	N/A	N/A	Unshielded, 1.8 m
2.	WLAN AP	ASUS	RT-AC66U	MSQ-RTAC66U	N/A	Unshielded,1.8m
3.	Bluetooth Earphone	Sony Ericsson	MW600	PY7DDA-2029	N/A	N/A
4.	SD Card	SanDisk	MicroSD HC	FCC DoC	N/A	N/A
5.	LG Charging Pad	LG	WCD-110	FCC DoC	N/A	N/A
6.	PMA Charging Pad	DURACELL	M-018B518A	FCC DoC	N/A	N/A
7.	USB Cable	N/A	N/A	N/A	N/A	N/A
8.	Adapter	N/A	N/A	N/A	N/A	N/A
9.	Earphone	Moto	SH38C16618	FCC DoC	Unshielded, 1.0 m	N/A

## 2.5 EUT Operation Test Setup

The RF test items, utility “QRCT” was installed in Notebook which was programmed in order to make the EUT get into the engineering modes to provide channel selection, power level, data rate and the application type and for continuous transmitting signals.



### 3 Test Result

#### 3.1 Unwanted Emissions Measurement

This section is to measure unwanted emissions through radiated measurement for band edge spurious emissions and out of band emissions measurement.

##### 3.1.1 Limit of Unwanted Emissions

- (1) For transmitters operating in the 5150-5250 MHz band: all emissions outside of the 5150-5350 MHz band shall not exceed an EIRP of -27dBm/MHz.

For transmitters operating in the 5250-5350 MHz band: all emissions outside of the 5150-5350 MHz band shall not exceed an EIRP of -27 dBm/MHz. Devices operating in the 5250-5350 MHz band that generate emissions in the 5150-5250 MHz band must meet all applicable technical requirements for operation in the 5150-5250 MHz band (including indoor use) or alternatively meet an out-of-band emission EIRP limit of -27 dBm/MHz in the 5150-5250 MHz band.

For transmitters operating in the 5470-5600 MHz and 5650-5725MHz band: all emissions outside of the 5470-5600 MHz and 5650-5725MHz band shall not exceed an EIRP of -27 dBm/MHz.

- (2) Unwanted spurious emissions fallen in restricted bands shall comply with the general field strength limits as below table,

Frequency (MHz)	Field Strength (microvolts/meter)	Measurement Distance (meters)
0.009 – 0.490	2400/F(kHz)	300
0.490 – 1.705	24000/F(kHz)	30
1.705 – 30.0	30	30
30 – 88	100	3
88 – 216	150	3
216 - 960	200	3
Above 960	500	3

**Note:** The following formula is used to convert the EIRP to field strength.

$$E = \frac{1000000\sqrt{30P}}{3} \mu\text{V/m, where P is the eirp (Watts)}$$

EIRP (dBm)	Field Strength at 3m (dBμV/m)
- 27	68.3



(3) KDB789033 D02 v02r01 G)2)c)

- (i) Section 15.407(b)(1) to (b)(3) specify the unwanted emission limits for the U-NII-1 and U-NII-2 bands. As specified, emissions above 1000 MHz that are outside of the restricted bands are subject to a peak emission limit of -27 dBm/MHz.<sup>3</sup>
- (ii) Section 15.407(b)(4) specifies the unwanted emission limit for the U-NII-3 band. A band emissions mask is specified in Section 15.407(b)(4)(i). The emission limits are in terms of a Peak detector. An alternative to the band emissions mask is specified in Section 15.407(b)(4)(ii). The alternative limits are based on the highest antenna gain specified in the filing. There are also marketing and importation restrictions for the devices using the alternative limit.<sup>4</sup>

**Note 3:** An out-of-band emission that complies with both the average and peak limits of Section 15.209 is not required to satisfy the -27 dBm/MHz peak emission limit.

**Note 4:** Only devices with antenna gains of 10 dBi or less may be approved using the emission limits specified in Section 15.247(d) till March 2, 2018; all other devices operating in this band must use the mask specified in Section 15.407(b)(4)(i).

### 3.1.2 Measuring Instruments

See list of measuring equipment of this test report.

### 3.1.3 Test Procedures

1. The testing follows FCC KDB 789033 D02 General UNII Test Procedures New Rules v02r01. Section G) Unwanted emissions measurement.

(1) Procedure for Unwanted Emissions Measurements Below 1000MHz

- RBW = 120 kHz
- VBW = 300 kHz
- Detector = Peak
- Trace mode = max hold

(2) Procedure for Peak Unwanted Emissions Measurements Above 1000 MHz

- RBW = 1 MHz
- VBW ≥ 3 MHz
- Detector = Peak
- Sweep time = auto
- Trace mode = max hold

(3) Procedures for Average Unwanted Emissions Measurements Above 1000MHz

- RBW = 1 MHz
- VBW = 10 Hz, when duty cycle is no less than 98 percent.
- VBW ≥ 1/T, when duty cycle is less than 98 percent where T is the minimum transmission duration over which the transmitter is on and is transmitting at its maximum power control level for the tested mode of operation.



2. The EUT was placed on a turntable with 0.8 meter for frequency below 1GHz and 1.5 meter for frequency above 1GHz respectively above ground.
3. The EUT was set 3 meters from the interference receiving antenna which was mounted on the top of a variable height antenna tower.
4. The antenna is a broadband antenna and its height is adjusted between one meter and four meters above ground to find the maximum value of the field strength for both horizontal polarization and vertical polarization of the antenna.
5. For each suspected emission, the EUT was arranged to its worst case and then adjust the antenna tower (from 1 m to 4 m) and turntable (from 0 degree to 360 degrees) to find the maximum reading.
6. For testing below 1GHz, if the emission level of the EUT in peak mode was 3 dB lower than the limit specified, then peak values of EUT will be reported, otherwise, the emissions will be repeated one by one using the CISPR quasi-peak method and reported.
7. For testing above 1GHz, the emission level of the EUT in peak mode was 20dB lower than average limit (that means the emission level in average mode also complies with the limit in average mode), then peak values of EUT will be reported, otherwise, the emissions will be measured in average mode again and reported.

### 3.1.4 Test Setup

For radiated emissions below 30MHz

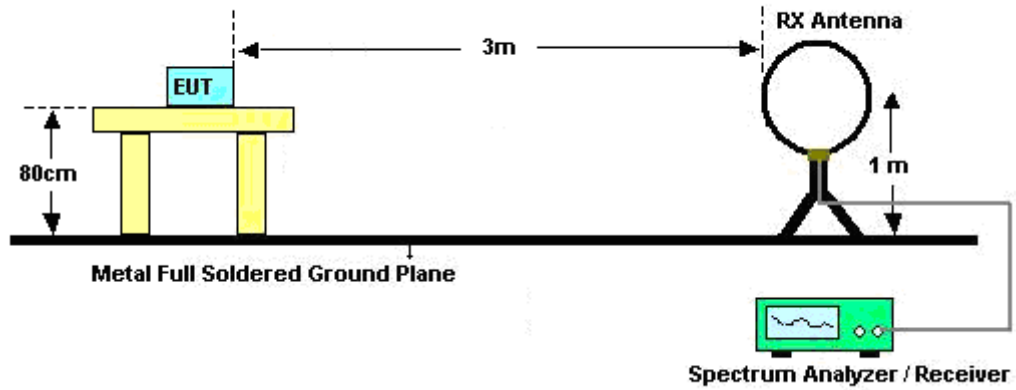

For radiated emissions from 30MHz to 1GHz

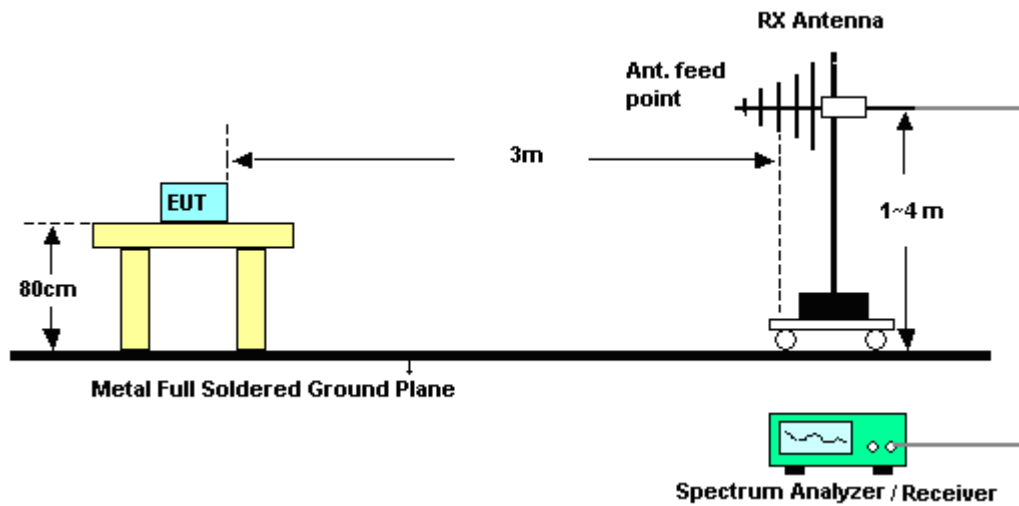

For radiated emissions above 1GHz

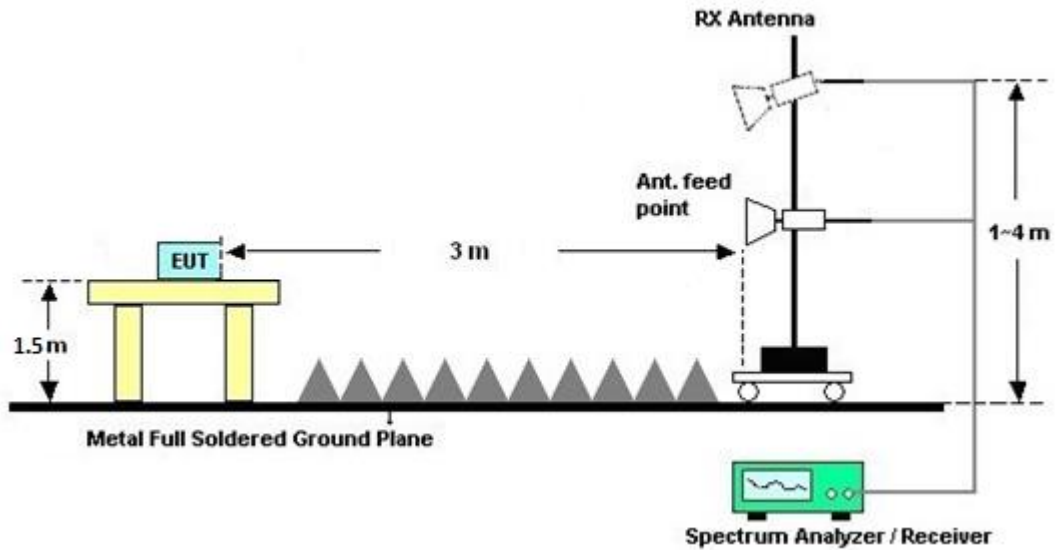

### 3.1.5 Test Results of Radiated Spurious Emissions (9 kHz ~ 30 MHz)

The low frequency, which started from 9 kHz to 30MHz, was pre-scanned and the result which was 20dB lower than the limit line was not reported.

There is a comparison data of both open-field test site and alternative test site - semi-Anechoic chamber according to 414788 D01 Radiated Test Site v01r01, and the result came out very similar.

### 3.1.6 Test Result of Radiated Spurious at Band Edges

Please refer to Appendix B and C.

### 3.1.7 Duty Cycle

Please refer to Appendix D.

### 3.1.8 Test Result of Radiated Spurious Emissions (30MHz ~ 10th Harmonic)

Please refer to Appendix B and C.



### 3.2 AC Conducted Emission Measurement

#### 3.2.1 Limit of AC Conducted Emission

For equipment that is designed to be connected to the public utility (AC) power line, the radio frequency voltage that is conducted back onto the AC power line on any frequency or frequencies within the band 150 kHz to 30 MHz shall not exceed the limits in the following table.

Frequency of emission (MHz)	Conducted limit (dB $\mu$ V)	
	Quasi-peak	Average
0.15-0.5	66 to 56*	56 to 46*
0.5-5	56	46
5-30	60	50

\*Decreases with the logarithm of the frequency.

#### 3.2.2 Measuring Instruments

See list of measuring equipment of this test report.

#### 3.2.3 Test Procedures

1. The EUT was placed 0.4 meter from the conducting wall of the shielding room was kept at least 80 centimeters from any other grounded conducting surface.
2. Connect EUT to the power mains through a line impedance stabilization network (LISN).
3. All the support units are connecting to the other LISN.
4. The LISN provides 50 ohm coupling impedance for the measuring instrument.
5. The FCC states that a 50 ohm, 50 microhenry LISN should be used.
6. Both sides of AC line were checked for maximum conducted interference.
7. The frequency range from 150 kHz to 30 MHz was searched.
8. Set the test-receiver system to Peak Detect Function and specified bandwidth with Maximum Hold Mode.



### 3.2.4 Test Setup

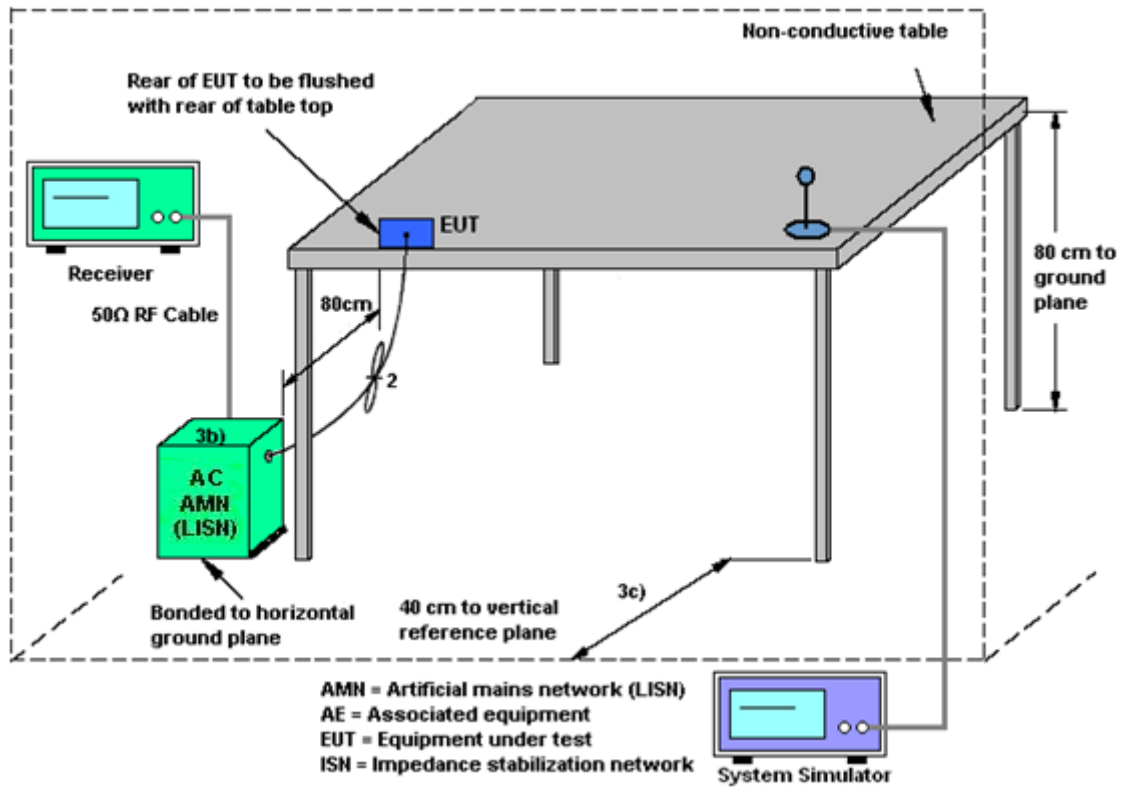

### 3.2.5 Test Result of AC Conducted Emission

Please refer to Appendix A.



## 4 List of Measuring Equipment

Instrument	Manufacturer	Model No.	Serial No.	Characteristics	Calibration Date	Test Date	Due Date	Remark
AC Power Source	ChainTek	APC-1000W	N/A	N/A	N/A	Mar. 29, 2019	N/A	Conduction (CO05-HY)
EMI Test Receiver	Rohde & Schwarz	ESR3	102388	9KHz~3.6GHz	Nov. 12, 2018	Mar. 29, 2019	Nov. 11, 2019	Conduction (CO05-HY)
LISN	Rohde & Schwarz	ENV216	100080	9kHz~30MHz	Nov. 14, 2018	Mar. 29, 2019	Nov. 13, 2019	Conduction (CO05-HY)
Software	Rohde & Schwarz	EMC32 V10.30	N/A	N/A	N/A	Mar. 29, 2019	N/A	Conduction (CO05-HY)
LF Cable	HUBER + SUHNER	RG-214/U	LF01	N/A	Dec. 31, 2018	Mar. 29, 2019	Dec. 30, 2019	Conduction (CO05-HY)
Pulse Limiter	Rohde & Schwarz	ESH3-Z2	100851	N/A	Dec. 31, 2018	Mar. 29, 2019	Dec. 30, 2019	Conduction (CO05-HY)
Amplifier	MITEQ	TTA1840-35-HG	1871923	18GHz~40GHz, VSWR : 2.5:1 max	Jul. 16, 2018	Mar. 21, 2019~ Mar. 27, 2019	Jul. 15, 2019	Radiation (03CH11-HY)
Amplifier	SONOMA	310N	187312	9kHz~1GHz	Dec. 04, 2018	Mar. 21, 2019~ Mar. 27, 2019	Dec. 03, 2019	Radiation (03CH11-HY)
Bilog Antenna	TESEQ	CBL 6111D&N-6-06	35414&AT-N0602	30MHz~1GHz	Oct. 13, 2018	Mar. 21, 2019~ Mar. 27, 2019	Oct. 12, 2019	Radiation (03CH11-HY)
Horn Antenna	SCHWARZBECK	BBHA 9120 D	9120D-1326	1GHz ~ 18GHz	Oct. 30, 2018	Mar. 21, 2019~ Mar. 27, 2019	Oct. 29, 2019	Radiation (03CH11-HY)
Loop Antenna	Rohde & Schwarz	HFH2-Z2	100488	9 kHz~30 MHz	Nov. 22, 2018	Mar. 21, 2019~ Mar. 27, 2019	Nov. 21, 2019	Radiation (03CH11-HY)
Preamplifier	Keysight	83017A	MY53270080	1GHz~26.5GHz	Nov. 14, 2018	Mar. 21, 2019~ Mar. 27, 2019	Nov. 13, 2020	Radiation (03CH11-HY)
Spectrum Analyzer	Keysight	N9010A	MY54200486	10Hz ~ 44GHz	Oct. 19, 2018	Mar. 21, 2019~ Mar. 27, 2019	Oct. 18, 2019	Radiation (03CH11-HY)
Antenna Mast	EMEC	AM-BS-4500-B	N/A	1~4m	N/A	Mar. 21, 2019~ Mar. 27, 2019	N/A	Radiation (03CH11-HY)
Turn Table	EMEC	TT 2000	N/A	0~360 Degree	N/A	Mar. 21, 2019~ Mar. 27, 2019	N/A	Radiation (03CH11-HY)
Preamplifier	Jet-Power	JPA0118-55-303K	1710001800054002	1GHz~18GHz	Apr. 17, 2018	Mar. 21, 2019~ Mar. 27, 2019	Apr. 16, 2019	Radiation (03CH11-HY)
SHF-EHF Horn Antenna	SCHWARZBECK	BBHA 9170	BBHA9170584	18GHz- 40GHz	Dec. 05, 2018	Mar. 21, 2019~ Mar. 27, 2019	Dec. 04, 2019	Radiation (03CH11-HY)
EMI Test Receiver	Keysight	N9038A(MXE)	MY53290045	N/A	Jan. 19, 2019	Mar. 21, 2019~ Mar. 27, 2019	Jan. 18, 2020	Radiation (03CH11-HY)
Software	Audix	E3 6.2009-8-24	RK-001042	N/A	N/A	Mar. 21, 2019~ Mar. 27, 2019	N/A	Radiation (03CH11-HY)
RF Cable	HUBER + SUHNER	SUCOFLEX 104	MY9837/4PE	9kHz-30MHz	Mar. 13, 2019	Mar. 21, 2019~ Mar. 27, 2019	Mar. 12, 2020	Radiation (03CH11-HY)
RF Cable	HUBER + SUHNER	SUCOFLEX 102	MY2859/2	30MHz-40GHz	Mar. 13, 2019	Mar. 21, 2019~ Mar. 27, 2019	Mar. 12, 2020	Radiation (03CH11-HY)
RF Cable	HUBER + SUHNER	SUCOFLEX 104	MY9837/4PE	30M-18G	Mar. 13, 2019	Mar. 21, 2019~ Mar. 27, 2019	Mar. 12, 2020	Radiation (03CH11-HY)
RF Cable	HUBER + SUHNER	SUCOFLEX 102	MY4274/2	30MHz-40GHz	Mar. 13, 2019	Mar. 21, 2019~ Mar. 27, 2019	Mar. 12, 2020	Radiation (03CH11-HY)
Filter	Wainwright	WHKX8-5872.5-6750-18000-40ST	SN3	6.75GHz High Pass	Sep. 17, 2018	Mar. 21, 2019~ Mar. 27, 2019	Sep. 16, 2019	Radiation (03CH11-HY)
Filter	Wainwright	WLK4-1000-1530-8000-40SS	SN11	1G Low Pass	Sep. 16, 2018	Mar. 21, 2019~ Mar. 27, 2019	Sep. 17, 2019	Radiation (03CH11-HY)
Filter	Wainwright	WHKX12-2700-3000-18000-60SS	SN3	2.7G High Pass	Sep. 16, 2018	Mar. 21, 2019~ Mar. 27, 2019	Sep. 17, 2019	Radiation (03CH11-HY)



## 5 Uncertainty of Evaluation

### Uncertainty of Conducted Emission Measurement (150kHz ~ 30MHz)

Measuring Uncertainty for a Level of Confidence of 95% ( $U = 2Uc(y)$ )	2.2
---	-----

### Uncertainty of Radiated Emission Measurement (30 MHz ~ 1000 MHz)

Measuring Uncertainty for a Level of Confidence of 95% ( $U = 2Uc(y)$ )	5.2
---	-----

### Uncertainty of Radiated Emission Measurement (1000 MHz ~ 18000 MHz)

Measuring Uncertainty for a Level of Confidence of 95% ( $U = 2Uc(y)$ )	5.5
---	-----

### Uncertainty of Radiated Emission Measurement (18000 MHz ~ 40000 MHz)

Measuring Uncertainty for a Level of Confidence of 95% ( $U = 2Uc(y)$ )	5.2
---	-----



## Appendix A. AC Conducted Emission Test Results

Test Engineer :	Rick Lin and Jimmy Chang	Temperature :	24~26°C
		Relative Humidity :	51~53%

# EUT Information

Report NO : 930415-06  
 Test Mode : Mode 2  
 Test Voltage : 120Vac/60Hz  
 Phase : Line

Full Spectrum

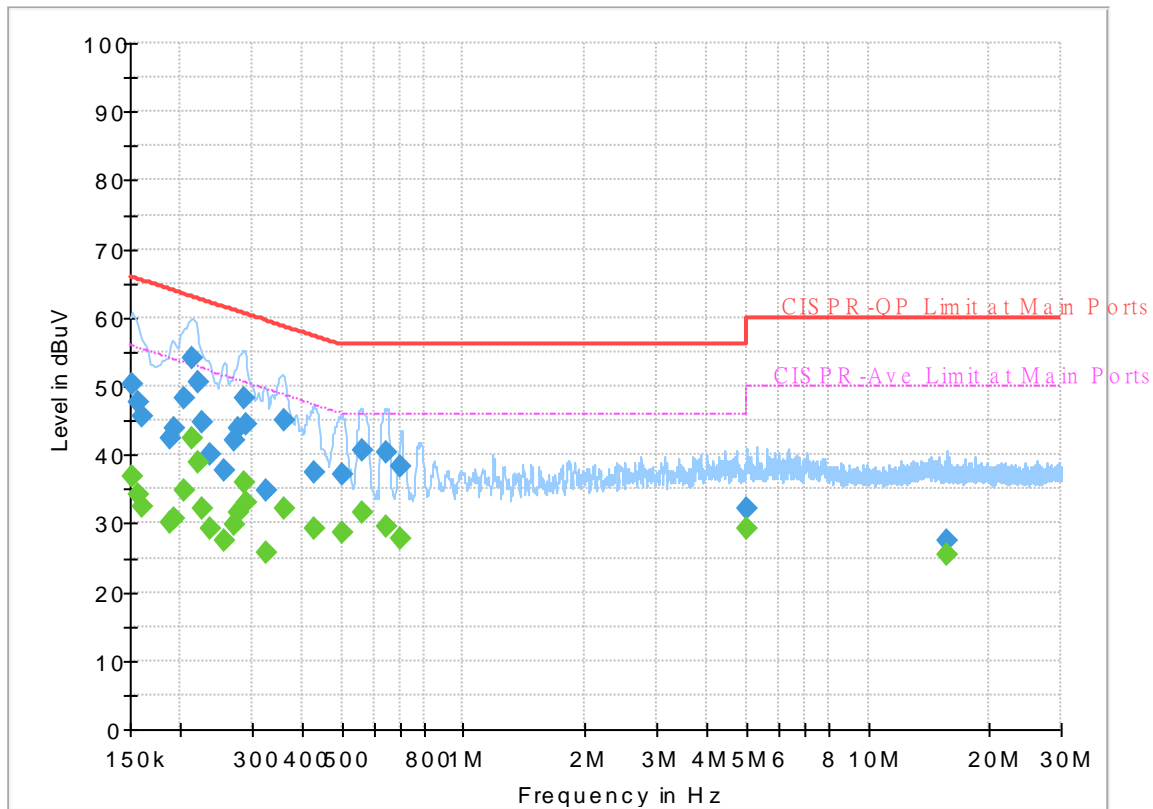

## Final\_Result

Frequency (MHz)	QuasiPeak (dBuV)	CAverage (dBuV)	Limit (dBuV)	Margin (dB)	Line	Filter	Corr. (dB)
0.152250	---	36.96	55.88	18.92	L1	OFF	19.5
0.152250	50.16	---	65.88	15.72	L1	OFF	19.5
0.156750	---	34.34	55.63	21.29	L1	OFF	19.5
0.156750	47.67	---	65.63	17.96	L1	OFF	19.5
0.161250	---	32.45	55.40	22.95	L1	OFF	19.5
0.161250	45.68	---	65.40	19.72	L1	OFF	19.5
0.188250	---	30.14	54.11	23.97	L1	OFF	19.5
0.188250	42.51	---	64.11	21.60	L1	OFF	19.5
0.192750	---	30.65	53.92	23.27	L1	OFF	19.5
0.192750	43.87	---	63.92	20.05	L1	OFF	19.5
0.204000	---	34.73	53.45	18.72	L1	OFF	19.5
0.204000	48.37	---	63.45	15.08	L1	OFF	19.5
0.213000	---	42.39	53.09	10.70	L1	OFF	19.5
0.213000	54.06	---	63.09	9.03	L1	OFF	19.5
0.219750	---	38.75	52.83	14.08	L1	OFF	19.5
0.219750	50.65	---	62.83	12.18	L1	OFF	19.5
0.226500	---	32.14	52.58	20.44	L1	OFF	19.5
0.226500	44.80	---	62.58	17.78	L1	OFF	19.5
0.237750	---	29.23	52.17	22.94	L1	OFF	19.5
0.237750	40.06	---	62.17	22.11	L1	OFF	19.5
0.255750	---	27.55	51.57	24.02	L1	OFF	19.5

0.255750	37.64	---	61.57	23.93	L1	OFF	19.5
0.271500	---	29.96	51.07	21.11	L1	OFF	19.5
0.271500	42.12	---	61.07	18.95	L1	OFF	19.5
0.276000	---	31.54	50.94	19.40	L1	OFF	19.5
0.276000	43.73	---	60.94	17.21	L1	OFF	19.5
0.287250	---	36.09	50.60	14.51	L1	OFF	19.5
0.287250	48.26	---	60.60	12.34	L1	OFF	19.5
0.291750	---	32.96	50.47	17.51	L1	OFF	19.5
0.291750	44.51	---	60.47	15.96	L1	OFF	19.5
0.325500	---	25.67	49.57	23.90	L1	OFF	19.5
0.325500	34.77	---	59.57	24.80	L1	OFF	19.5
0.359250	---	32.17	48.75	16.58	L1	OFF	19.5
0.359250	45.05	---	58.75	13.70	L1	OFF	19.5
0.426750	---	29.14	47.32	18.18	L1	OFF	19.5
0.426750	37.46	---	57.32	19.86	L1	OFF	19.5
0.501000	---	28.56	46.00	17.44	L1	OFF	19.5
0.501000	37.05	---	56.00	18.95	L1	OFF	19.5
0.559500	---	31.54	46.00	14.46	L1	OFF	19.5
0.559500	40.60	---	56.00	15.40	L1	OFF	19.5
0.642750	---	29.54	46.00	16.46	L1	OFF	19.6
0.642750	40.47	---	56.00	15.53	L1	OFF	19.6
0.699000	---	27.90	46.00	18.10	L1	OFF	19.6
0.699000	38.31	---	56.00	17.69	L1	OFF	19.6
5.005500	---	29.39	50.00	20.61	L1	OFF	19.7
5.005500	32.24	---	60.00	27.76	L1	OFF	19.7
15.612000	---	25.33	50.00	24.67	L1	OFF	20.1
15.612000	27.39	---	60.00	32.61	L1	OFF	20.1

# EUT Information

Report NO : 930415-06  
 Test Mode : Mode 2  
 Test Voltage : 120Vac/60Hz  
 Phase : Neutral

Full Spectrum

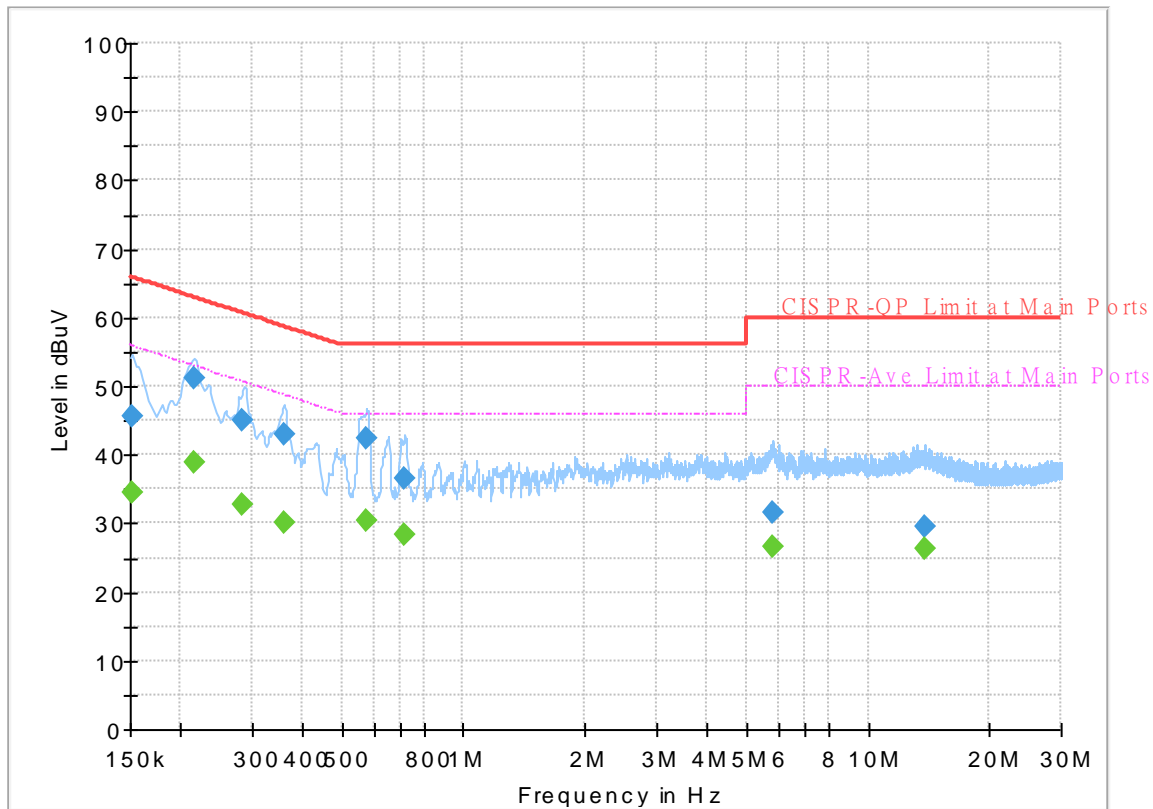

## Final\_Result

Frequency (MHz)	QuasiPeak (dBuV)	CAverage (dBuV)	Limit (dBuV)	Margin (dB)	Line	Filter	Corr. (dB)
0.152250	---	34.57	55.88	21.31	N	OFF	19.5
0.152250	45.63	---	65.88	20.25	N	OFF	19.5
0.215250	---	38.83	53.00	14.17	N	OFF	19.5
0.215250	51.18	---	63.00	11.82	N	OFF	19.5
0.285000	---	32.69	50.67	17.98	N	OFF	19.5
0.285000	44.95	---	60.67	15.72	N	OFF	19.5
0.359250	---	30.01	48.75	18.74	N	OFF	19.5
0.359250	42.93	---	58.75	15.82	N	OFF	19.5
0.575250	---	30.44	46.00	15.56	N	OFF	19.5
0.575250	42.34	---	56.00	13.66	N	OFF	19.5
0.717000	---	28.39	46.00	17.61	N	OFF	19.6
0.717000	36.67	---	56.00	19.33	N	OFF	19.6
5.820000	---	26.72	50.00	23.28	N	OFF	19.8
5.820000	31.69	---	60.00	28.31	N	OFF	19.8
13.809750	---	26.43	50.00	23.57	N	OFF	20.1
13.809750	29.56	---	60.00	30.44	N	OFF	20.1



### Appendix B. Radiated Spurious Emission

Test Engineer :	Hao Hsu and Ken Wu	Temperature :	21~26°C
		Relative Humidity :	50~56%

Band 3 - 5470~5725MHz

WIFI 802.11a (Band Edge @ 3m)

WIFI Ant. 1	Note	Frequency ( MHz )	Level ( dBμV/m )	Over Limit ( dB )	Limit Line ( dBμV/m )	Read Level ( dBμV )	Antenna Factor ( dB/m )	Path Loss ( dB )	Preamp Factor ( dB )	Ant Pos ( cm )	Table Pos ( deg )	Peak Avg. ( P/A )	Pol. ( H/V )
802.11a CH 140 5700MHz	*	5700	103.26	-	-	93.92	32	10.51	33.17	100	13	P	H
	*	5700	96.13	-	-	86.79	32	10.51	33.17	100	13	A	H
		5754.28	52.69	-15.51	68.2	43.23	32.11	10.54	33.19	100	13	P	H
													H
													H
													H
	*	5700	105.49	-	-	96.15	32	10.51	33.17	400	25	P	V
	*	5700	97.89	-	-	88.55	32	10.51	33.17	400	25	A	V
		5729.8	52.48	-15.72	68.2	43.07	32.06	10.53	33.18	400	25	P	V
													V
													V
													V
Remark	1. No other spurious found. 2. All results are PASS against Peak and Average limit line.												





**Band 3 - 5470~5725MHz**

**WIFI 802.11a (Harmonic @ 3m)**

WIFI Ant.	Note	Frequency	Level	Over Limit	Limit Line	Read Level	Antenna Factor	Path Loss	Preamp Factor	Ant Pos	Table Pos	Peak Avg.	Pol.	
1		( MHz )	( dBμV/m )	( dB )	( dBμV/m )	( dBμV )	( dB/m )	( dB )	( dB )	( cm )	( deg )	( P/A )	( H/V )	
802.11a CH 140 5700MHz		11400	46.45	-27.55	74	51.73	39.7	16.42	61.4	100	0	P	H	
		17100	48.45	-19.75	68.2	45.73	40.1	20.58	57.96	100	0	P	H	
													H	
													H	
			11400	47.02	-26.98	74	52.3	39.7	16.42	61.4	100	0	P	V
			17100	47.79	-20.41	68.2	45.07	40.1	20.58	57.96	100	0	P	V
														V
														V
Remark	1. No other spurious found. 2. All results are PASS against Peak and Average limit line.													



Emission below 1GHz

WIFI 802.11a (LF @ 3m)

WIFI Ant. 1	Note	Frequency ( MHz )	Level ( dBµV/m )	Over Limit ( dB )	Limit Line ( dBµV/m )	Read Level (dBµV)	Antenna Factor ( dB/m )	Path Loss ( dB )	Preamp Factor ( dB )	Ant Pos ( cm )	Table Pos ( deg )	Peak Avg. (P/A)	Pol. (H/V)	
802.11a LF		94.02	22.23	-21.27	43.5	38.2	15.04	1.32	32.33	-	-	P	H	
		177.44	31.65	-11.85	43.5	47.1	14.93	1.88	32.26	100	0	P	H	
		273.47	27.2	-18.8	46	38.36	18.78	2.26	32.2	-	-	P	H	
		566.41	27.47	-18.53	46	30.48	25.93	3.25	32.19	-	-	P	H	
		756.53	31.05	-14.95	46	31.34	27.87	3.83	31.99	-	-	P	H	
		951.5	33	-13	46	28.93	30.64	4.31	30.88	-	-	P	H	
														H
														H
														H
														H
														H
														H
														H
			45.52	32.86	-7.14	40	48.01	16.32	0.9	32.37	100	0	P	V
			62.98	24.59	-15.41	40	44.25	11.62	1.08	32.36	-	-	P	V
			92.08	23.35	-20.15	43.5	39.51	14.86	1.31	32.33	-	-	P	V
			196.84	25.14	-18.36	43.5	40.64	14.8	1.94	32.24	-	-	P	V
			302.57	26.17	-19.83	46	36.87	19.1	2.38	32.18	-	-	P	V
			940.83	32.68	-13.32	46	29.36	30	4.29	30.97	-	-	P	V
														V
													V	
													V	
													V	
													V	
													V	
Remark	1. No other spurious found. 2. All results are PASS against limit line.													



**Note symbol**

*	<b>Fundamental Frequency</b> which can be ignored. However, the level of any unwanted emissions shall not exceed the level of the fundamental frequency.
!	Test result is <b>over limit</b> line.
P/A	<b>Peak</b> or <b>Average</b>
H/V	<b>Horizontal</b> or <b>Vertical</b>



A calculation example for radiated spurious emission is shown as below:

WIFI Ant. 1	Note	Frequency ( MHz )	Level ( dBμV/m )	Over Limit ( dB )	Limit Line ( dBμV/m )	Read Level ( dBμV )	Antenna Factor ( dB/m )	Path Loss ( dB )	Preamp Factor ( dB )	Ant Pos ( cm )	Table Pos ( deg )	Peak Avg. ( P/A )	Pol. ( H/V )
802.11b		2390	55.45	-18.55	74	54.51	32.22	4.58	35.86	103	308	P	H
CH 01		2390	43.54	-10.46	54	42.6	32.22	4.58	35.86	103	308	A	H
2412MHz													

1. Path Loss(dB) = Cable loss(dB) + Filter loss(dB) + Attenuator loss(dB)
2. Level(dBμV/m) = Antenna Factor(dB/m) + Path Loss(dB) + Read Level(dBμV) - Preamp Factor(dB)
3. Over Limit(dB) = Level(dBμV/m) – Limit Line(dBμV/m)

**For Peak Limit @ 2390MHz:**

1. Level(dBμV/m)
  - = Antenna Factor(dB/m) + Path Loss(dB) + Read Level(dBμV) - Preamp Factor(dB)
  - = 32.22(dB/m) + 4.58(dB) + 54.51(dBμV) – 35.86 (dB)
  - = 55.45 (dBμV/m)
2. Over Limit(dB)
  - = Level(dBμV/m) – Limit Line(dBμV/m)
  - = 55.45(dBμV/m) – 74(dBμV/m)
  - = -18.55(dB)

**For Average Limit @ 2390MHz:**

1. Level(dBμV/m)
  - = Antenna Factor(dB/m) + Path Loss(dB) + Read Level(dBμV) - Preamp Factor(dB)
  - = 32.22(dB/m) + 4.58(dB) + 42.6(dBμV) – 35.86 (dB)
  - = 43.54 (dBμV/m)
2. Over Limit(dB) = Level(dBμV/m) – Limit Line(dBμV/m)
  - = 43.54(dBμV/m) – 54(dBμV/m)
  - = -10.46(dB)

**Both peak and average measured complies with the limit line, so test result is “PASS”.**



## Appendix C. Radiated Spurious Emission Plots

Test Engineer :	Hao Hsu and Ken Wu	Temperature :	21~26°C
		Relative Humidity :	50~56%

**Band 3 - 5470~5725MHz**  
**WIFI 802.11a (Band Edge @ 3m)**

WIFI	Band 3 5470~5725MHz Band Edge @ 3m	
ANT	802.11a CH140 5700MHz	
1	Horizontal	Fundamental
<b>Peak</b>	<p>Date: 2019-03-22</p> <p>Site : 03CHI1-HY Condition : PEAK_BE(UMI)_B3 3m HORN 9120d-HF HORIZONTAL RBW:1000.000KHz VBW:3000.000KHz SWT:Auto Detector : Peak Project : 930415-06</p>	<p>Date: 2019-03-22</p> <p>Site : 03CHI1-HY Condition : PEAK(UMI) 3m HORN 9120d-HF HORIZONTAL RBW:1000.000KHz VBW:3000.000KHz SWT:Auto Detector : Peak Project : 930415-06</p>

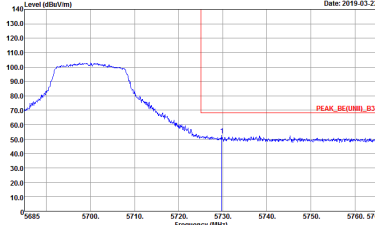
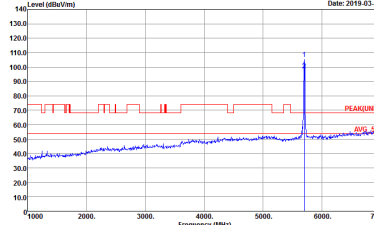

WIFI	Band 3 5470~5725MHz Band Edge @ 3m	
ANT	802.11a CH140 5700MHz	
1	Vertical	Fundamental
Peak	 <p>Date: 2019-03-22</p> <p>Site : 03CH11-HY            Condition : PEAK_BE[UNII]_B3 3m HORN 9120D-HF VERTICAL            RBW:1000.000KHz VBW:3000.000KHz SWT:Auto            Detector : Peak            Project : 930415-06</p>	 <p>Date: 2019-03-22</p> <p>Site : 03CH11-HY            Condition : PEAK[UNII] 3m HORN 9120D-HF VERTICAL            RBW:1000.000KHz VBW:3000.000KHz SWT:Auto            Detector : Peak            Project : 930415-06</p>



Band 3 - 5470~5725MHz
WIFI 802.11a (Harmonic @ 3m)

Table with 2 columns: Horizontal and Vertical. Each column contains a graph of Level (dBuV/m) vs Frequency (MHz) and associated test parameters like Site, Condition, Detector, and Project.

Peak
Avg.



Emission below 1GHz  
5GHz WIFI 802.11a (LF)

WIFI	5GHz WIFI	
ANT	802.11a LF	
1	Horizontal	Vertical
QP / Peak	<p>Site : 03CH11-HY Condition : QP 3m BT-LOG 6111D-LF_ETC HORIZONTAL Detector : Peak Project : 930415-06</p>	<p>Site : 03CH11-HY Condition : QP 3m BT-LOG 6111D-LF_ETC VERTICAL Detector : Peak Project : 930415-06</p>





### Appendix D. Duty Cycle Plots

Band	Duty Cycle (%)	T(us)	1/T(kHz)	VBW Setting
802.11a	98.28	-	-	10Hz

802.11a

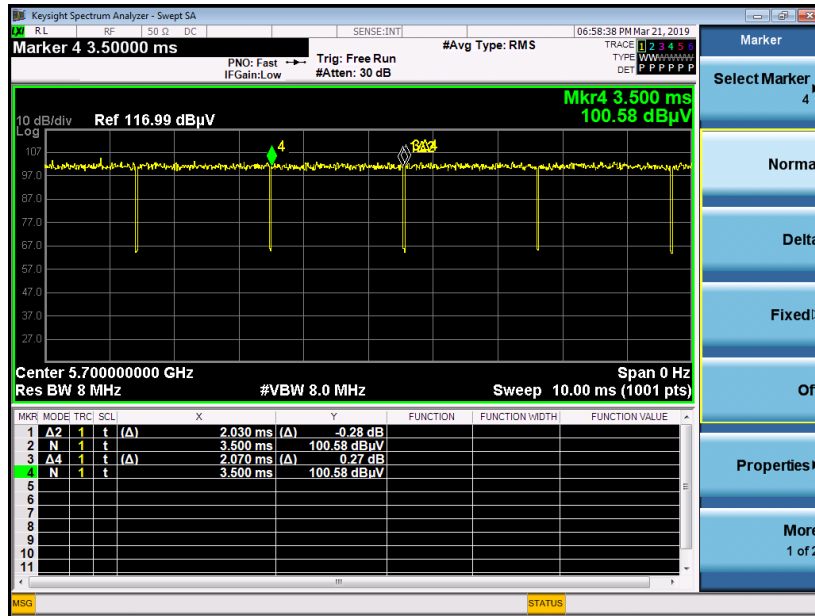

—————THE END—————