

# FCC SAR Test Report

APPLICANT : Motorola Mobility LLC  
EQUIPMENT : Mobile Cellular Phone  
BRAND NAME : Motorola  
FCC ID : IHDT56XJ1  
STANDARD : FCC 47 CFR Part 2 (2.1093)  
ANSI/IEEE C95.1-1992  
IEEE 1528-2013

We, Sporton International (Kunshan) Inc., would like to declare that the tested sample has been evaluated in accordance with the procedures and had been in compliance with the applicable technical standards.

The test results in this report apply exclusively to the tested model / sample. Without written approval of Sporton International (Kunshan) Inc., the test report shall not be reproduced except in full.



Approved by: Mark Qu / Manager



**Sporton International (Kunshan) Inc.**

**No.3-2 Ping-Xiang Rd, Kunshan Development Zone Kunshan City Jiangsu Province 215335 China**



Table of Contents

1. Statement of Compliance ..... 4

2. Administration Data ..... 5

3. Guidance Applied..... 5

4. Equipment Under Test (EUT) Information ..... 6

    4.1 General Information ..... 6

    4.2 Specification of Accessory ..... 7

    4.3 General LTE SAR Test and Reporting Considerations ..... 8

5. Proximity Sensor Triggering Test.....10

    5.1 Proximity sensor triggering distances(Per KDB616217§6.2) .....10

    5.2 Tilt angle influences to proximity sensor triggering(Per KDB616217 §6.4).....20

6. RF Exposure Limits.....21

    6.1 Uncontrolled Environment.....21

    6.2 Controlled Environment.....21

7. Specific Absorption Rate (SAR).....22

    7.1 Introduction .....22

    7.2 SAR Definition.....22

8. System Description and Setup .....23

    8.1 E-Field Probe .....24

    8.2 Data Acquisition Electronics (DAE) .....24

    8.3 Phantom.....25

    8.4 Device Holder.....26

9. Measurement Procedures .....27

    9.1 Spatial Peak SAR Evaluation .....27

    9.2 Power Reference Measurement.....28

    9.3 Area Scan .....28

    9.4 Zoom Scan.....29

    9.5 Volume Scan Procedures.....29

    9.6 Power Drift Monitoring.....29

10. Test Equipment List.....30

11. System Verification .....31

    11.1 Tissue Simulating Liquids .....31

    11.2 Tissue Verification .....32

    11.3 System Performance Check Results .....33

12. RF Exposure Positions .....34

    12.1 Ear and handset reference point.....34

    12.2 Definition of the cheek position .....35

    12.3 Definition of the tilt position .....36

    12.4 Body Worn Accessory .....37

    12.5 Product Specific 10g SAR Exposure.....38

    12.6 Wireless Router.....38

13. Conducted RF Output Power (Unit: dBm).....39

14. Antenna Location .....117

15. SAR Test Results .....118

    15.1 Head SAR .....121

    15.2 Hotspot SAR .....124

    15.3 Body Worn Accessory SAR.....129

    15.4 Product specific 10g SAR .....132

    15.5 Repeated SAR Measurement .....136

16. Simultaneous Transmission Analysis .....137

    16.1 Head Exposure Conditions .....138

    16.2 Hotspot Exposure Conditions.....140

    16.3 Body-Worn Accessory Exposure Conditions .....142

    16.4 Product specific 10g SAR Exposure Conditions.....143

    16.5 SPLSR Evaluation and Analysis.....144

17. Supplemental Tuner Tests Results.....155

    17.1 Supplemental Head SAR Results .....156

    17.2 Supplemental Body SAR Results.....157

18. Uncertainty Assessment .....158

19. References .....159

Appendix A. Plots of System Performance Check

Appendix B. Plots of High SAR Measurement

Appendix C. DASYS Calibration Certificate

Appendix D. Test Setup Photos



### Revision History

REPORT NO.	VERSION	DESCRIPTION	ISSUED DATE
FA851503-01	Rev. 01	Initial issue of report	Aug. 14, 2018



### 1. Statement of Compliance

The maximum results of Specific Absorption Rate (SAR) found during testing for **Motorola Mobility LLC, Mobile Cellular Phone**, are as follows.

Highest 1g SAR Summary						
Equipment Class	Frequency Band		Head (Separation 0mm)	Hotspot (Separation 5mm)	Body-worn (Separation 5mm)	Highest Simultaneous Transmission 1g SAR (W/kg)
			1g SAR (W/kg)			
Licensed	GSM	GSM850	0.26	0.92	0.92	1.58
		GSM1900	0.16	0.71	0.40	
	WCDMA	Band V	0.34	<b>1.18</b>	<b>1.18</b>	
		Band II	0.24	0.88	1.13	
	CDMA2000	BC0	0.47	0.77	0.83	
		BC1	0.29	0.93	1.16	
	LTE	Band 13	0.26	0.88	0.88	
		Band 5	0.33	<b>1.18</b>	<b>1.18</b>	
		Band 66/Band 4	0.57	<b>1.18</b>	1.17	
		Band 2	0.32	0.88	1.13	
Band 7		0.79	0.65	0.65		
DTS	WLAN	2.4GHz WLAN	0.47	0.37	0.37	1.55
NII		5GHz WLAN	<b>1.11</b>	0.91	1.16	1.58
DSS	Bluetooth	2.4GHz Bluetooth	0.44	0.32	0.32	1.49
Highest 10g SAR Summary						
Equipment Class	Frequency Band		Product Specific 10g SAR (W/kg) (Separation 0mm)			Highest Simultaneous Transmission 10g SAR (W/kg)
Licensed	GSM	GSM850	0.83			3.98
		GSM1900	3.39			
	WCDMA	Band V	0.67			
		Band II	3.36			
	CDMA2000	BC0	3.25			
		BC1	2.76			
	LTE	Band 13	2.41			
		Band 5	2.92			
		Band 66/Band 4	3.32			
		Band 2	<b>3.48</b>			
Band 7		3.47				
NII	WLAN	5GHz WLAN	1.50			3.98
Date of Testing:			2018/5/17 ~ 2018/7/30			
<b>Remark:</b> This device supports LTE B4 and B66. Since the supported frequency span for LTE B4 falls completely within the supports frequency span for LTE B66, both LTE bands have the same target power, and both LTE bands share the same transmission path; therefore, SAR was only assessed for LTE B66.						

This device is in compliance with Specific Absorption Rate (SAR) for general population/uncontrolled exposure limits (1.6 W/kg for Partial-Body 1g SAR, 4.0 W/kg for Product Specific 10g SAR) specified in FCC 47 CFR part 2 (2.1093) and ANSI/IEEE C95.1-1992, and had been tested in accordance with the measurement methods and procedures specified in IEEE 1528-2013 and FCC KDB publications.



## 2. Administration Data

Testing Laboratory	
Test Site	Sporton International (Kunshan) Inc.
Test Site Location	No.3-2 Ping-Xiang Rd, Kunshan Development Zone Kunshan City Jiangsu Province 215335 China TEL : +86-512-57900158 FAX : +86-512-57900958

Applicant	
Company Name	Motorola Mobility LLC
Address	222 W,Merchandise Mart Plaza, Chicago IL 60654 USA

Manufacturer	
Company Name	Motorola Mobility LLC
Address	222 W,Merchandise Mart Plaza, Chicago IL 60654 USA

## 3. Guidance Applied

The Specific Absorption Rate (SAR) testing specification, method, and procedure for this device is in accordance with the following standards:

- FCC 47 CFR Part 2 (2.1093)
- ANSI/IEEE C95.1-1992
- IEEE 1528-2013
- FCC KDB 865664 D01 SAR Measurement 100 MHz to 6 GHz v01r04
- FCC KDB 865664 D02 SAR Reporting v01r02
- FCC KDB 447498 D01 General RF Exposure Guidance v06
- FCC KDB 648474 D04 SAR Evaluation Considerations for Wireless Handsets v01r03
- FCC KDB 248227 D01 802.11 Wi-Fi SAR v02r02
- FCC KDB 941225 D01 3G SAR Procedures v03r01
- FCC KDB 941225 D05 SAR for LTE Devices v02r05
- FCC KDB 941225 D05A Rel.10 LTE SAR Test Guidance v01r02
- FCC KDB 941225 D06 Hotspot Mode SAR v02r01
- FCC KDB 616217 D04 SAR for laptop and tablets v01r02



## 4. Equipment Under Test (EUT) Information

### 4.1 General Information

Product Feature & Specification	
Equipment Name	Mobile Cellular Phone
Brand Name	Motorola
FCC ID	IHDT56XJ1
IMEI Code	355550090016176
Wireless Technology and Frequency Range	GSM850: 824.2 MHz ~ 848.8 MHz GSM1900: 1850.2 MHz ~ 1909.8 MHz WCDMA Band II: 1852.4 MHz ~ 1907.6 MHz WCDMA Band V: 826.4 MHz ~ 846.6 MHz CDMA2000 BC0: 824.7 MHz ~ 848.31 MHz CDMA 2000 BC1: 1851.25 MHz ~ 1908.75 MHz LTE Band 2: 1850.7 MHz ~ 1909.3 MHz LTE Band 4: 1710.7 MHz ~ 1754.3 MHz LTE Band 5: 824.7 MHz ~ 848.3 MHz LTE Band 7: 2502.5 MHz ~ 2567.5 MHz LTE Band 13: 779.5 MHz ~ 784.5 MHz LTE Band 66: 1710.7 MHz ~ 1779.3 MHz WLAN 2.4GHz Band: 2412 MHz ~ 2462 MHz WLAN 5.2GHz Band: 5180 MHz ~ 5240 MHz WLAN 5.3GHz Band: 5260 MHz ~ 5320 MHz WLAN 5.5GHz Band: 5500 MHz ~ 5720 MHz WLAN 5.8GHz Band: 5745 MHz ~ 5825 MHz Bluetooth: 2402 MHz ~ 2480 MHz NFC : 13.56 MHz
Mode	GSM/GPRS/EGPRS RMC/AMR 12.2Kbps HSDPA HSUPA DC-HSDPA HSPA+ (16QAM uplink is not supported) CDMA2000 : 1xRTT/1xEv-Do(Rev.0)/1xEv-Do(Rev.A) LTE: QPSK, 16QAM, 64QAM WLAN 2.4GHz 802.11b/g/n HT20 WLAN 5GHz 802.11a/n HT20/HT40 WLAN 5GHz 802.11ac VHT20/VHT40/VHT80 Bluetooth v3.0+EDR, Bluetooth v4.2 LE, Bluetooth v5.0 LE NFC
HW Version	DVT2
SW Version	fastboot_messi_verizon_oem_vzw_userdebug_8.1.0_ODX28.56_50ee_intcfg-test-keys_vzw
GSM / (E)GPRS Transfer mode	Class B – EUT cannot support Packet Switched and Circuit Switched Network simultaneously but can automatically switch between Packet and Circuit Switched Network.
EUT Stage	Identical Prototype
Remark:	<ol style="list-style-type: none"> <li>1. This device supports VoIP in GPRS, EGPRS, CDMA, WCDMA and LTE (e.g. for 3rd-party VoIP), LTE supports VoLTE operation.</li> <li>2. This device 2.4GHz WLAN support hotspot operation and Bluetooth support tethering applications.</li> <li>3. This device 2.4GHz WLAN/5.2GHz WLAN/5.8GHz WLAN support hotspot operation, and 5.2GHz WLAN/5.8GHz WLAN supports WiFi Direct (GC/GO), and 5.3GHz / 5.5GHz supports WiFi Direct (GC only).</li> <li>4. This device does not support DTM operation and supports GRPS/EGPRS mode up to multi-slot class 12.</li> <li>5. This device has two WWAN transmitter antennas. More details of the antennas can refer to antenna location chapter. WWAN antenna 1 frequency bands include GSM850/1900, WCDMA B2 / B5, CDMA BC0 / BC1 and LTE B2 / B4 / B5 / B13 / B66, WWAN antenna 2 frequency bands only includes LTE B7.</li> <li>6. The device employs proximity sensors that detect the presence of the user's body at the front or back faces of the device. When front or back body worn condition is detected, GSM850/1900, WCDMA B2 / B5, CDMA BC0 / BC1 and LTE B2 / B4 / B5 / B7 / B13 / B66 reduced power will be active. (P-sensor can't work at detecting presence of the user's body at the four edges of the device.)</li> <li>7. When hotspot mode is enabled, power reduction will be activated to limit the maximum power of GSM850/1900,</li> </ol>

- WCDMA B2 / B5, CDMA BC0 / BC1 and LTE B2 / B4 / B5 / B7 / B13 / B66.
8. For GSM850/1900, WCDMA B5, CDMA BC0 and LTE B5 / B7 / B13, this device hotspot reduced power and P-sensor reduced power level are the same. So only show one reduced power level for hotspot reduced power and P-sensor reduced power for this application.
  9. The device additionally employs proximity sensors that detect the presence of tissue near the currently active transmit antenna, the handheld reduced power table which at GSM1900, WCDMA B2, CDMA BC1 and LTE band LTE B2 / B4 / B7 / B66 reduced powers will be active.
  10. This device implements antenna tuning techniques for several WWAN operating modes and frequencies for the purpose of improving antenna efficiency over a broad range of frequencies. Specifically, these techniques are employed in the GSM1900, WCDMA B2 / B5, CDMA BC0 / BC1 and LTE B2 / B4 / B5 / B13 / B66 modes of WWAN antenna 1, and GSM1900 only GSM mode supports antenna tuning technique. In this report SAR was measured according to the normally required SAR configurations with the tuner active and worst tune state (auto tune) was used for SAR testing. The detail descriptions of the antenna tuner are included in the operational description and supplemental data for additional information on section 17.
  11. The device can match with several MODs and these Mods share similarities and maintain the requirements based on "FCC Moto Mods System Level Testing Guidance 16Jan2018 ". And similarity justifications which are "OpDes\_Justification about Phone only and Phone with MODs SAR result"," OpDes\_Justification For Moto Mods", "OpDes\_Justification For Moto Z 3rd Gen"," OpDes\_Passive Mods supplemental SAR Report" have been provided separately.
  12. This is a variant report, updated sensor on reduced power level for WCDMA B2/CDMA BC1 and LTE B2/ B4/B66. So, for body worn SAR, we re-test body worn SAR for these bands with new power level, All other test data please referred to Sporton Report Number FA851503.

## 4.2 Specification of Accessory

Specification of Accessory			
AC Adapter 1	Brand Name	Motorola (Salom)	Model Name SC-22
	Power Rating	I/P: 100-240 Vac, 500mA, O/P: 5Vdc,3000mA or 9Vdc,1600mA or 12Vdc,1200mA	
AC Adapter 2	Brand Name	Motorola (Chenyang)	Model Name SC-22
	Power Rating	I/P: 100-240 Vac, 500mA, O/P: 5Vdc,3000mA or 9Vdc,1600mA or 12Vdc,1200mA	
AC Adapter 3	Brand Name	Motorola (Salom)	Model Name SC-51
	Power Rating	I/P: 100-240 Vac, 600mA, O/P: 5Vdc,3000mA or 9Vdc,2000mA or 12Vdc,1500mA	
AC Adapter 4	Brand Name	Motorola (Chenyang)	Model Name SC-51
	Power Rating	I/P: 100-240 Vac, 600mA, O/P: 5Vdc,3000mA or 9Vdc,2000mA or 12Vdc,1500mA	
Battery	Brand Name	Motorola (Sunwoda)	Model Name JS40
	Power Rating	3.8Vdc,3000mAh	Type Li-ion
USB Cable 1	Brand Name	Motorola (Cabletech)	Model Name SKN6473A
	Signal Line Type	1.0 meter, shielded cable, without ferrite core	
USB Cable 2	Brand Name	Motorola (Luxshare)	Model Name SKN6473A
	Signal Line Type	1.0 meter, shielded cable, without ferrite core	
Audio Cable	Brand Name	Motorola (Luxshare)	Model Name SC18C27844
	Signal Line Type	0.08 meter, shielded cable, without ferrite core	



**4.3 General LTE SAR Test and Reporting Considerations**

Summarized necessary items addressed in KDB 941225 D05 v02r05																																																															
FCC ID	IHDT56XJ1																																																														
Equipment Name	Mobile Cellular Phone																																																														
Operating Frequency Range of each LTE transmission band	LTE Band 2: 1850.7 MHz ~ 1909.3 MHz LTE Band 4: 1710.7 MHz ~ 1754.3 MHz LTE Band 5: 824.7 MHz ~ 848.3 MHz LTE Band 7: 2502.5 MHz ~ 2567.5 MHz LTE Band 13: 779.5 MHz ~ 784.5 MHz LTE Band 66: 1710.7 MHz ~ 1779.3 MHz																																																														
Channel Bandwidth	LTE Band 2: 1.4MHz, 3MHz, 5MHz, 10MHz, 15MHz, 20MHz LTE Band 4: 1.4MHz, 3MHz, 5MHz, 10MHz, 15MHz, 20MHz LTE Band 5: 1.4MHz, 3MHz, 5MHz, 10MHz LTE Band 7: 5MHz, 10MHz, 15MHz, 20MHz LTE Band 13: 5MHz, 10MHz LTE Band 66: 1.4MHz, 3MHz, 5MHz, 10MHz, 15MHz, 20MHz																																																														
Uplink Modulations Used	QPSK, 16QAM and 64QAM																																																														
LTE Voice / Data requirements	Voice and Data																																																														
LTE Release Version	R11, Cat11																																																														
CA support	Yes, Downlink Only																																																														
LTE MPR permanently built-in by design	<p><b>Table 6.2.3-1: Maximum Power Reduction (MPR) for Power Class 1, 2 and 3</b></p> <table border="1"> <thead> <tr> <th rowspan="2">Modulation</th> <th colspan="6">Channel bandwidth / Transmission bandwidth (<math>N_{RB}</math>)</th> <th rowspan="2">MPR (dB)</th> </tr> <tr> <th>1.4 MHz</th> <th>3.0 MHz</th> <th>5 MHz</th> <th>10 MHz</th> <th>15 MHz</th> <th>20 MHz</th> </tr> </thead> <tbody> <tr> <td>QPSK</td> <td>&gt; 5</td> <td>&gt; 4</td> <td>&gt; 8</td> <td>&gt; 12</td> <td>&gt; 16</td> <td>&gt; 18</td> <td>≤ 1</td> </tr> <tr> <td>16 QAM</td> <td>≤ 5</td> <td>≤ 4</td> <td>≤ 8</td> <td>≤ 12</td> <td>≤ 16</td> <td>≤ 18</td> <td>≤ 1</td> </tr> <tr> <td>16 QAM</td> <td>&gt; 5</td> <td>&gt; 4</td> <td>&gt; 8</td> <td>&gt; 12</td> <td>&gt; 16</td> <td>&gt; 18</td> <td>≤ 2</td> </tr> <tr> <td>64 QAM</td> <td>≤ 5</td> <td>≤ 4</td> <td>≤ 8</td> <td>≤ 12</td> <td>≤ 16</td> <td>≤ 18</td> <td>≤ 2</td> </tr> <tr> <td>64 QAM</td> <td>&gt; 5</td> <td>&gt; 4</td> <td>&gt; 8</td> <td>&gt; 12</td> <td>&gt; 16</td> <td>&gt; 18</td> <td>≤ 3</td> </tr> <tr> <td>256 QAM</td> <td colspan="6">≥ 1</td> <td>≤ 5</td> </tr> </tbody> </table>	Modulation	Channel bandwidth / Transmission bandwidth ( $N_{RB}$ )						MPR (dB)	1.4 MHz	3.0 MHz	5 MHz	10 MHz	15 MHz	20 MHz	QPSK	> 5	> 4	> 8	> 12	> 16	> 18	≤ 1	16 QAM	≤ 5	≤ 4	≤ 8	≤ 12	≤ 16	≤ 18	≤ 1	16 QAM	> 5	> 4	> 8	> 12	> 16	> 18	≤ 2	64 QAM	≤ 5	≤ 4	≤ 8	≤ 12	≤ 16	≤ 18	≤ 2	64 QAM	> 5	> 4	> 8	> 12	> 16	> 18	≤ 3	256 QAM	≥ 1						≤ 5
Modulation	Channel bandwidth / Transmission bandwidth ( $N_{RB}$ )						MPR (dB)																																																								
	1.4 MHz	3.0 MHz	5 MHz	10 MHz	15 MHz	20 MHz																																																									
QPSK	> 5	> 4	> 8	> 12	> 16	> 18	≤ 1																																																								
16 QAM	≤ 5	≤ 4	≤ 8	≤ 12	≤ 16	≤ 18	≤ 1																																																								
16 QAM	> 5	> 4	> 8	> 12	> 16	> 18	≤ 2																																																								
64 QAM	≤ 5	≤ 4	≤ 8	≤ 12	≤ 16	≤ 18	≤ 2																																																								
64 QAM	> 5	> 4	> 8	> 12	> 16	> 18	≤ 3																																																								
256 QAM	≥ 1						≤ 5																																																								
LTE A-MPR	In the base station simulator configuration, Network Setting value is set to NS_01 to disable A-MPR during SAR testing and the LTE SAR tests was transmitting on all TTI frames (Maximum TTI)																																																														
Spectrum plots for RB configuration	A properly configured base station simulator was used for the SAR and power measurement; therefore, spectrum plots for each RB allocation and offset configuration are not included in the SAR report.																																																														
Power reduction applied to satisfy SAR compliance	Yes 1. The device employs proximity sensors that detect the presence of the user's body at the front or back faces of the device. When front or back body worn condition is detected, LTE B2 / B4 / B5 / B7 / B13 / B66 reduced power will be active. (P-sensor can't work at detecting presence of the user's body at the four edges of the device.) 2. When hotspot mode is enabled, power reduction will be activated to limit the maximum power of LTE B2 / B4 / B5 / B7 / B13 / B66. 3. The device additionally employs proximity sensors that detect the presence of tissue near the currently active transmit antenna, the handheld reduced power table which at LTE B2 / B4 / B7 / B66 reduced powers will be active.																																																														
LTE Carrier Aggregation Combinations	Inter-Band and Intra-Band possible combinations and the detail power verification please referred to section 13.																																																														
LTE Carrier Aggregation Additional Information	This device supports maximum of 3 carriers in the downlink. Additional following LTE Release features are not supported: Relay, HetNet, Enhanced MIMO, eICI, WiFi Offloading, MDH, eMBMA, Cross-Carrier Scheduling, Enhanced SC-FDMA.																																																														





Transmission (H, M, L) channel numbers and frequencies in each LTE band												
LTE Band 2												
	Bandwidth 1.4 MHz		Bandwidth 3 MHz		Bandwidth 5 MHz		Bandwidth 10 MHz		Bandwidth 15 MHz		Bandwidth 20 MHz	
	Ch. #	Freq. (MHz)	Ch. #	Freq. (MHz)	Ch. #	Freq. (MHz)	Ch. #	Freq. (MHz)	Ch. #	Freq. (MHz)	Ch. #	Freq. (MHz)
L	18607	1850.7	18615	1851.5	18625	1852.5	18650	1855	18675	1857.5	18700	1860
M	18900	1880	18900	1880	18900	1880	18900	1880	18900	1880	18900	1880
H	19193	1909.3	19185	1908.5	19175	1907.5	19150	1905	19125	1902.5	19100	1900
LTE Band 4												
	Bandwidth 1.4 MHz		Bandwidth 3 MHz		Bandwidth 5 MHz		Bandwidth 10 MHz		Bandwidth 15 MHz		Bandwidth 20 MHz	
	Ch. #	Freq. (MHz)	Ch. #	Freq. (MHz)	Ch. #	Freq. (MHz)	Ch. #	Freq. (MHz)	Ch. #	Freq. (MHz)	Ch. #	Freq. (MHz)
L	19957	1710.7	19965	1711.5	19975	1712.5	20000	1715	20025	1717.5	20050	1720
M	20175	1732.5	20175	1732.5	20175	1732.5	20175	1732.5	20175	1732.5	20175	1732.5
H	20393	1754.3	20385	1753.5	20375	1752.5	20350	1750	20325	1747.5	20300	1745
LTE Band 5												
	Bandwidth 1.4 MHz		Bandwidth 3 MHz		Bandwidth 5 MHz		Bandwidth 10 MHz					
	Ch. #	Freq. (MHz)	Ch. #	Freq. (MHz)	Ch. #	Freq. (MHz)	Ch. #	Freq. (MHz)	Ch. #	Freq. (MHz)	Ch. #	Freq. (MHz)
L	20407	824.7	20415	825.5	20425	826.5	20450	829				
M	20525	836.5	20525	836.5	20525	836.5	20525	836.5				
H	20643	848.3	20635	847.5	20625	846.5	20600	844				
LTE Band 7												
	Bandwidth 5 MHz		Bandwidth 10 MHz		Bandwidth 15 MHz		Bandwidth 20 MHz					
	Ch. #	Freq. (MHz)	Ch. #	Freq. (MHz)	Ch. #	Freq. (MHz)	Ch. #	Freq. (MHz)	Ch. #	Freq. (MHz)	Ch. #	Freq. (MHz)
L	20775	2502.5	20800	2505	20825	2507.5	20850	2510				
M	21100	2535	21100	2535	21100	2535	21100	2535				
H	21425	2567.5	21400	2565	21375	2562.5	21350	2560				
LTE Band 13												
	Bandwidth 5 MHz				Bandwidth 10 MHz							
	Channel #		Freq.(MHz)		Channel #		Freq.(MHz)		Channel #		Freq.(MHz)	
L	23205		779.5		23230		782					
M	23230		782									
H	23255		784.5									
LTE Band 66												
	Bandwidth 1.4 MHz		Bandwidth 3 MHz		Bandwidth 5 MHz		Bandwidth 10 MHz		Bandwidth 15 MHz		Bandwidth 20 MHz	
	Ch. #	Freq. (MHz)	Ch. #	Freq. (MHz)	Ch. #	Freq. (MHz)	Ch. #	Freq. (MHz)	Ch. #	Freq. (MHz)	Ch. #	Freq. (MHz)
L	131979	1710.7	131987	1711.5	131997	1712.5	132022	1715	132047	1717.5	132072	1720
M	132322	1745	132322	1745	132322	1745	132322	1745	132322	1745	132322	1745
H	132665	1779.3	132657	1778.5	132647	1777.5	132622	1775	132597	1772.5	132572	1770

## 5. Proximity Sensor Triggering Test

### 5.1 Proximity sensor triggering distances(Per KDB616217§6.2)

1. Proximity sensor triggering distance testing was performed according to the procedures outlined in KDB 616217 D04 section 6.2, and EUT moving further away from the flat phantom and EUT moving toward the flat phantom were both assessed and the tissue-equivalent medium for highest frequency (2600MHz) and lowest (850MHz) frequency was used for proximity sensor triggering testing.
2. Capacitive proximity sensors placed coincident with antenna elements at the top and bottom ends of the phone are utilized to determine when the device comes in proximity of the user's body at the front or back of the device.
3. The output power will reduce to body worn power level when top and bottom sensor pad be detected, the output power will reduce to handheld power level when bottom sensor pad only be detected.
4. The sensors used to detect the proximity of the user's body (Body-worn condition) at the front or back surface of the device use a detection threshold distance. The data shown in the sections below shows the distance(s). When the sensor is active, GSM850/1900, WCDMA B2 / B5, CDMA BC0 / BC1 and LTE B2 / B4 / B5 / B7 / B13 / B66 reduced power will be active.
5. The device additionally employs proximity sensors that detect the presence of tissue near the currently active transmit antenna (if that antenna may require reduced power relative the Default power table in order to meet extremity SAR limits). The control logic is such that, if the Body-Worn, At-Head or WiFi Hotspot conditions are not detected, but tissue (as a finger or hand, for example) is detected near the transmitting antenna, the handheld reduced power table which at GSM1900, WCDMA B2, CDMA BC1 and LTE band LTE B2 / B4 / B7 / B66 will be applied.

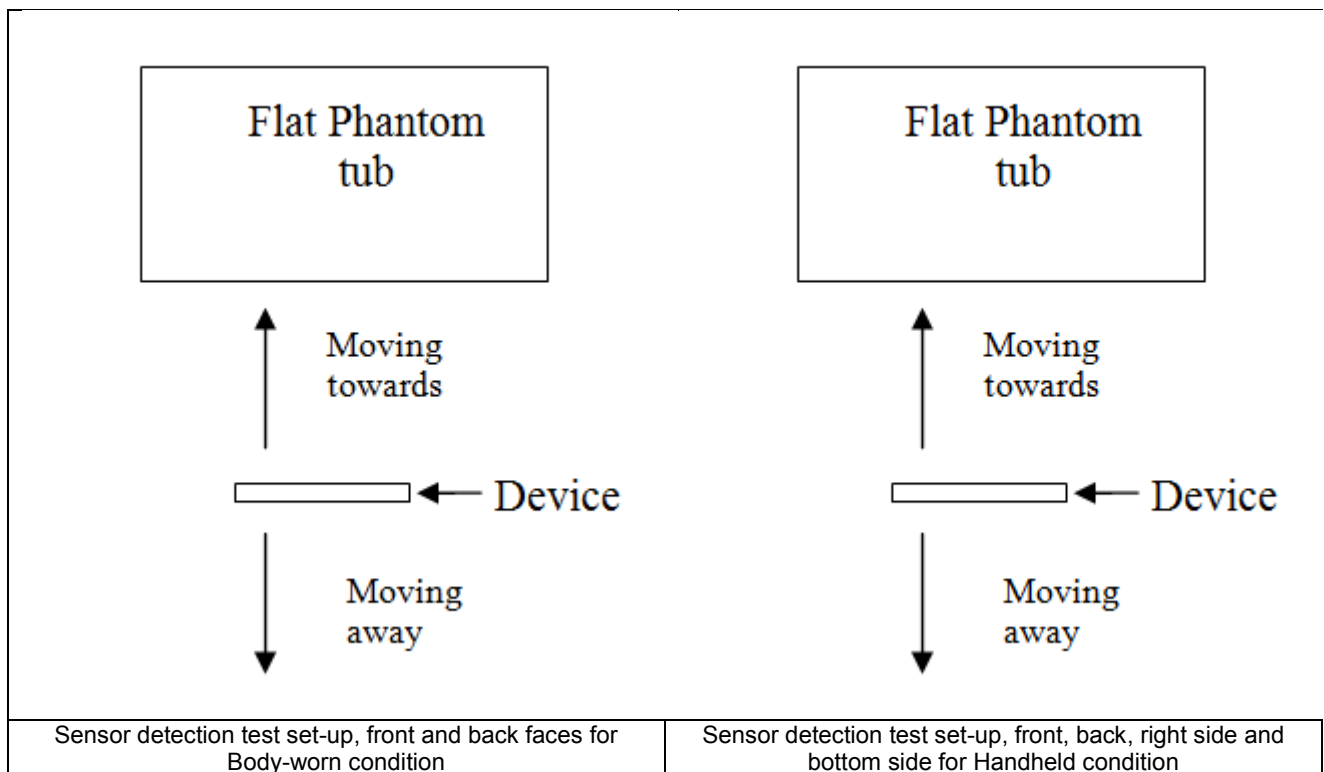



Proximity Sensor Triggering Distance (mm)				
Condition	Body-worn			
Frequency Band	GSM850/1900, WCDMA B2 / B5, CDMA BC0 / BC1 and LTE B2 / B4 / B5 / B7 / B13 / B66			
Position	Front		Back	
	Moving towards	Moving away	Moving towards	Moving away
Minimum	17	22	17	23

Proximity Sensor Triggering Distance (mm)												
Condition	Handheld											
Frequency Band	LTE B7						GSM1900, WCDMA B2, CDMA BC1 and LTE band LTE B2 / B4 / B66					
	Front		Back		Right Side		Front		Back		Bottom Side	
Position	Moving towards	Moving away	Moving towards	Moving away	Moving towards	Moving away	Moving towards	Moving away	Moving towards	Moving away	Moving towards	Moving away
Minimum	6	9	8	12	6	10	6	8	8	9	9	11

<Sensor Trigger Distance and Measured Power>

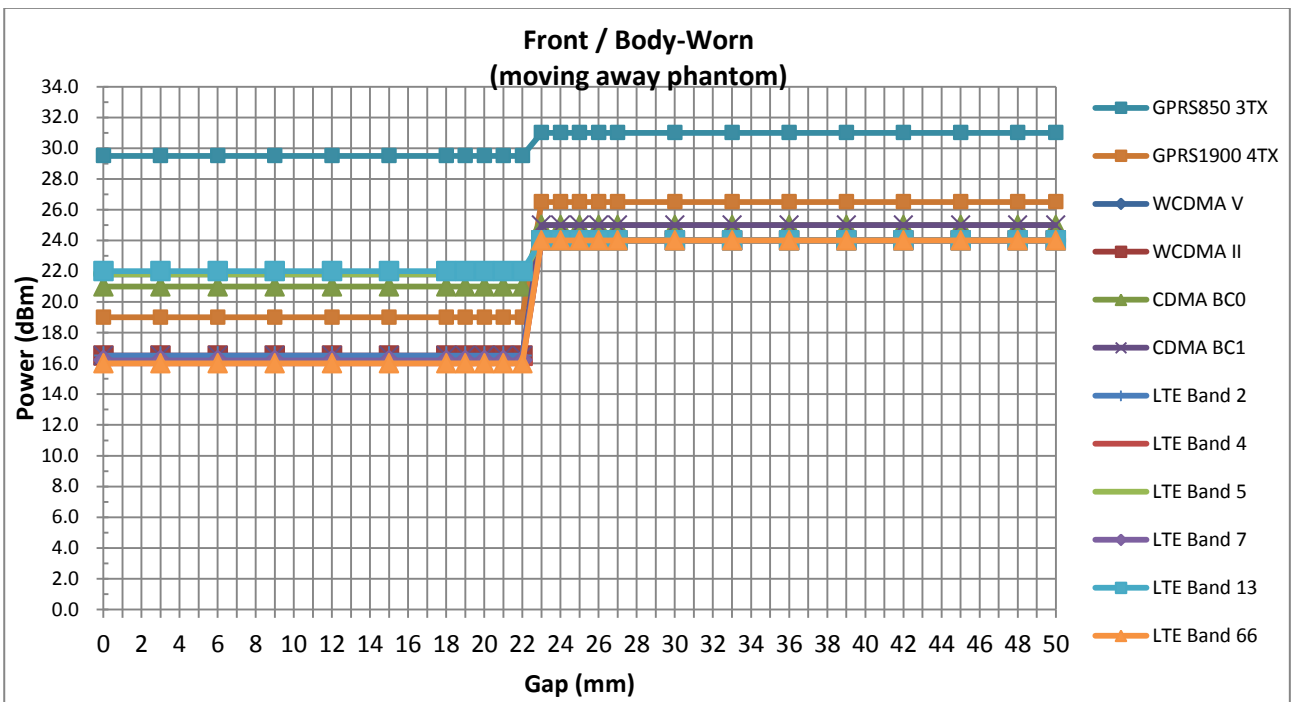
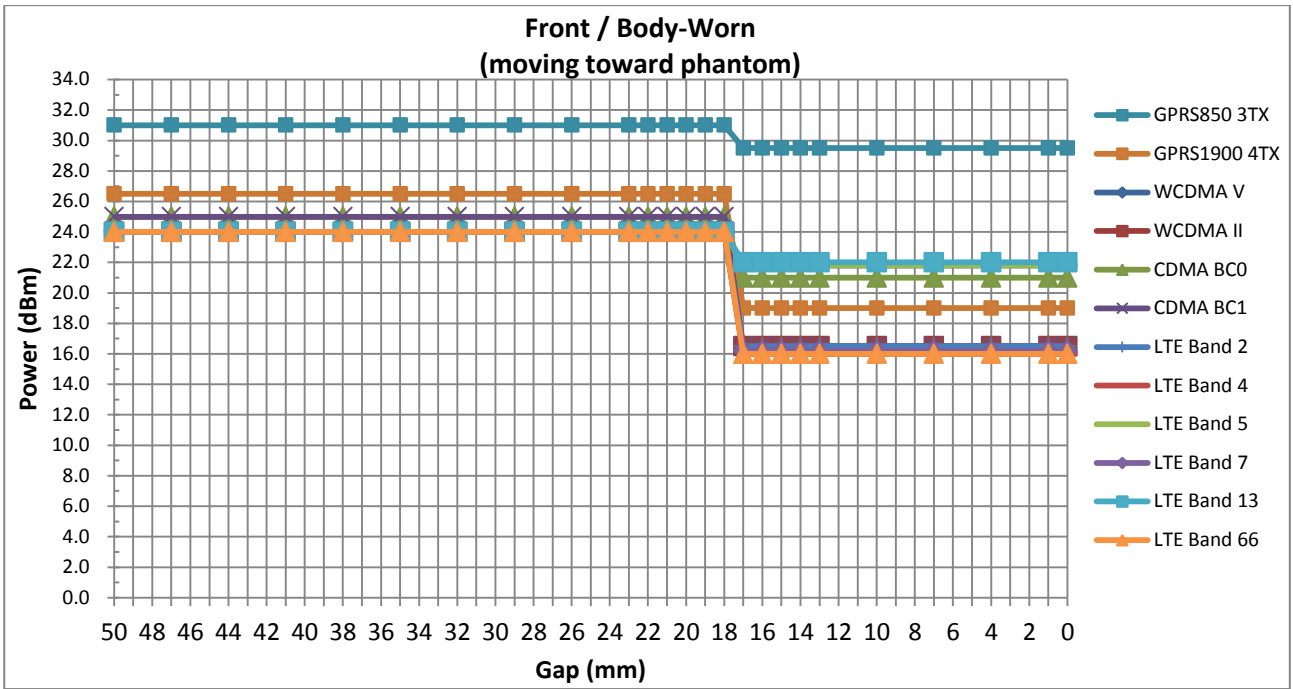

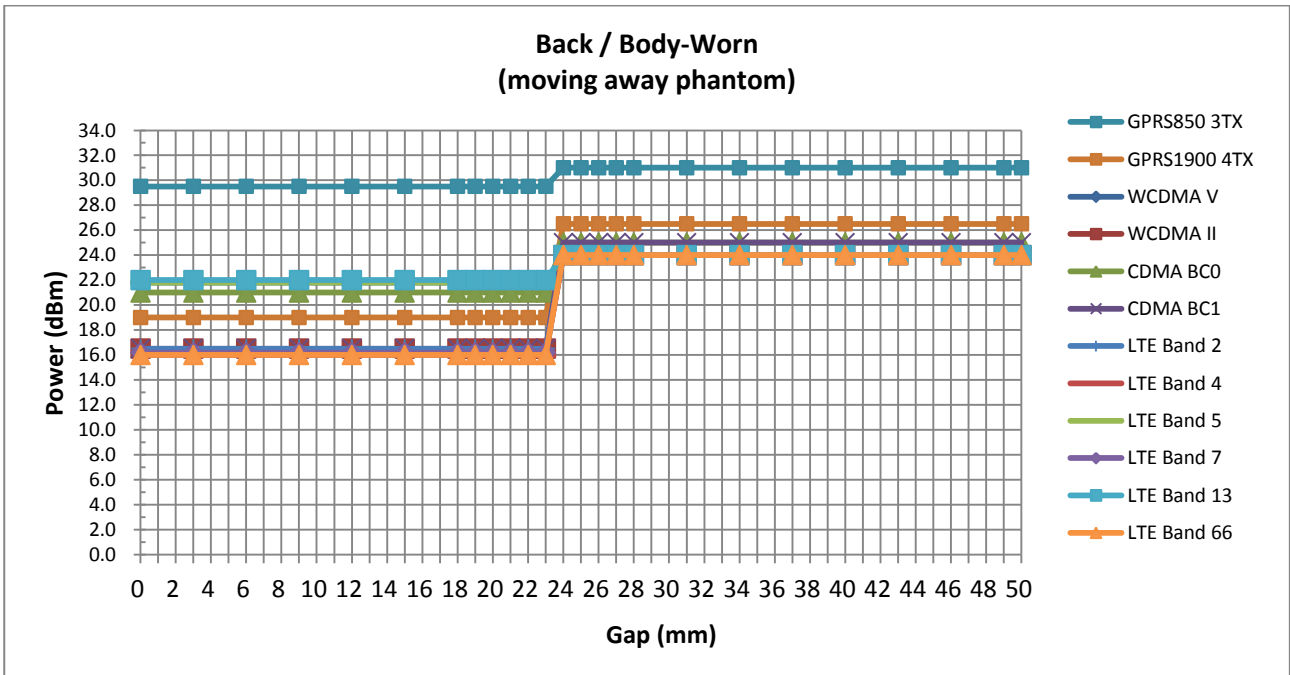
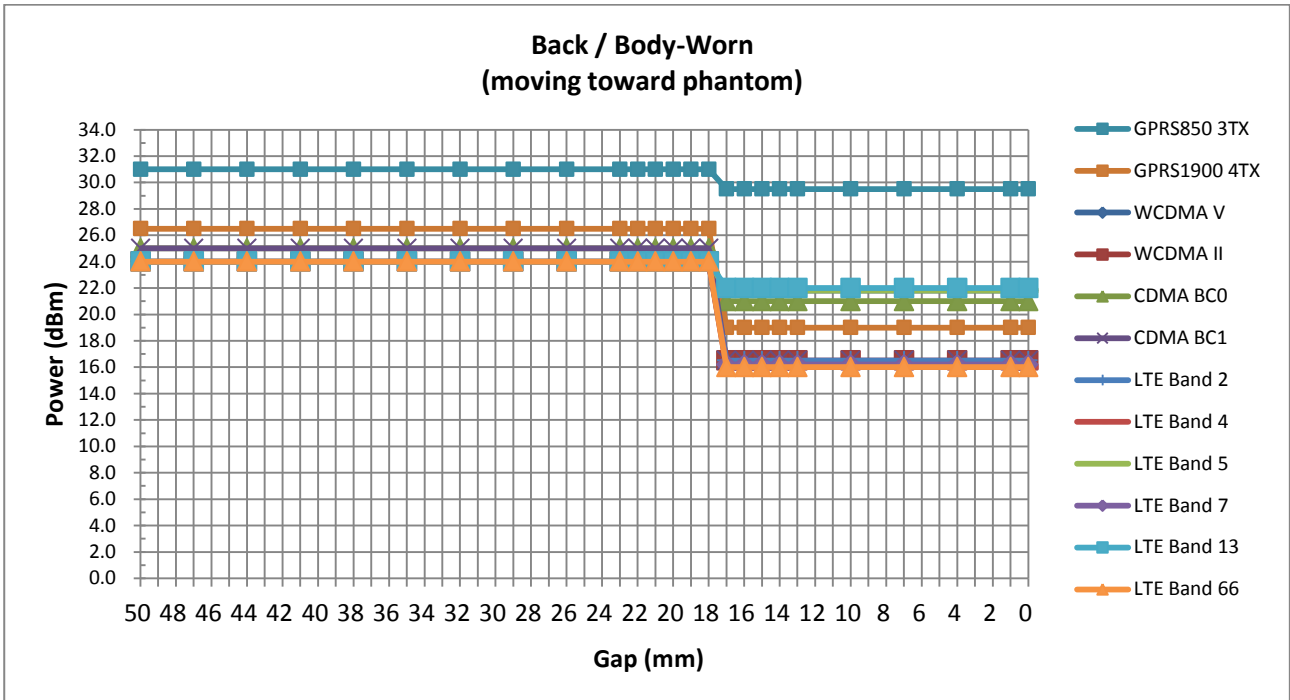

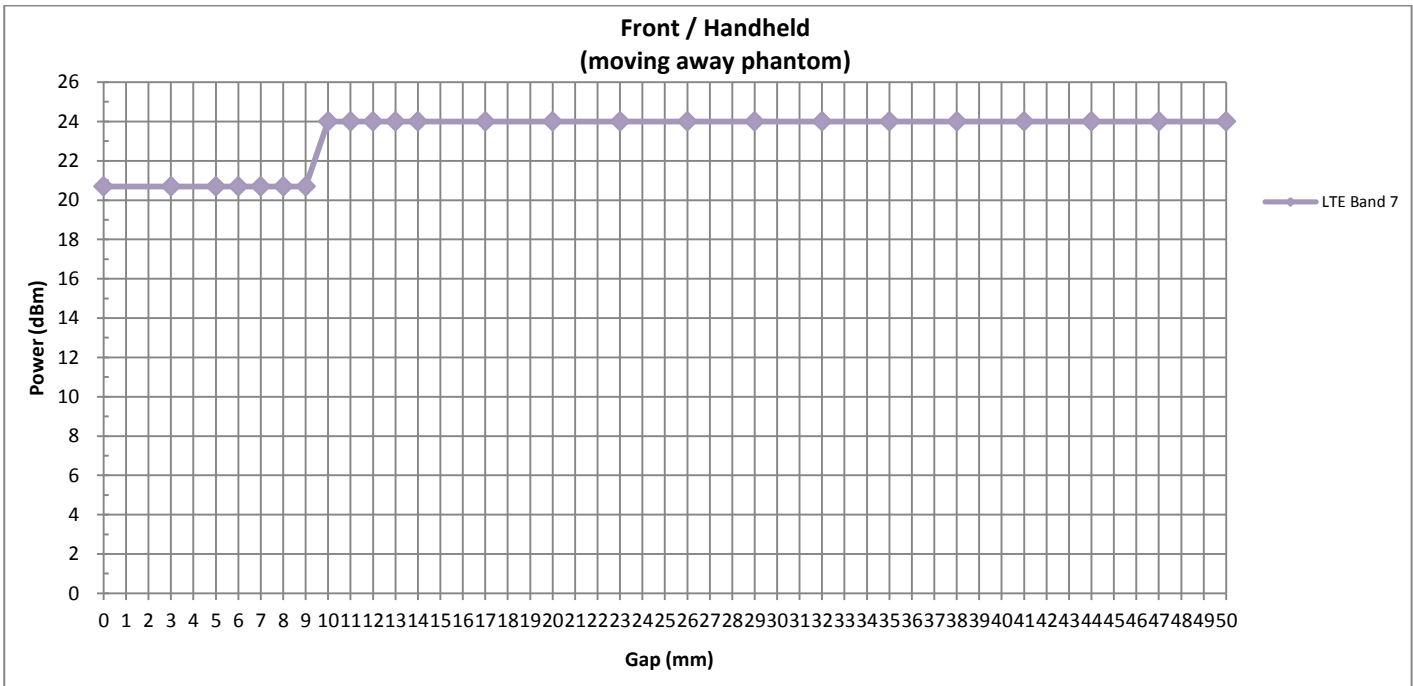
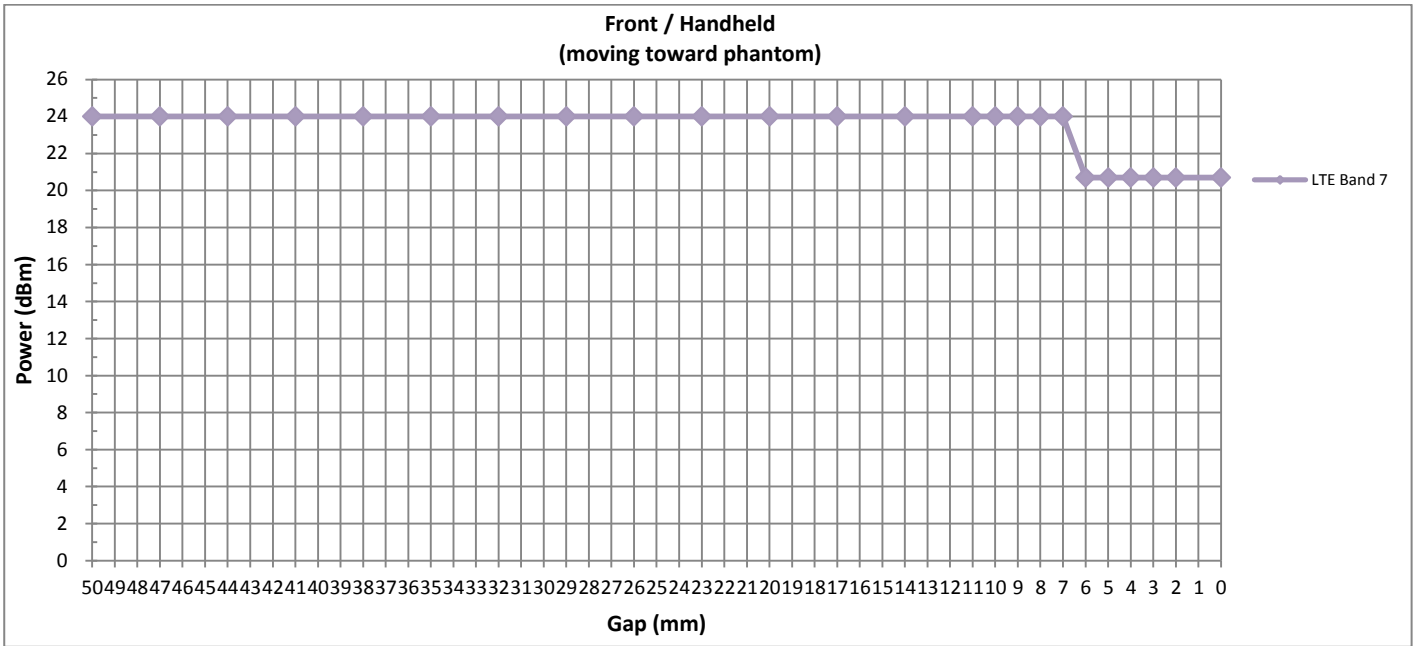

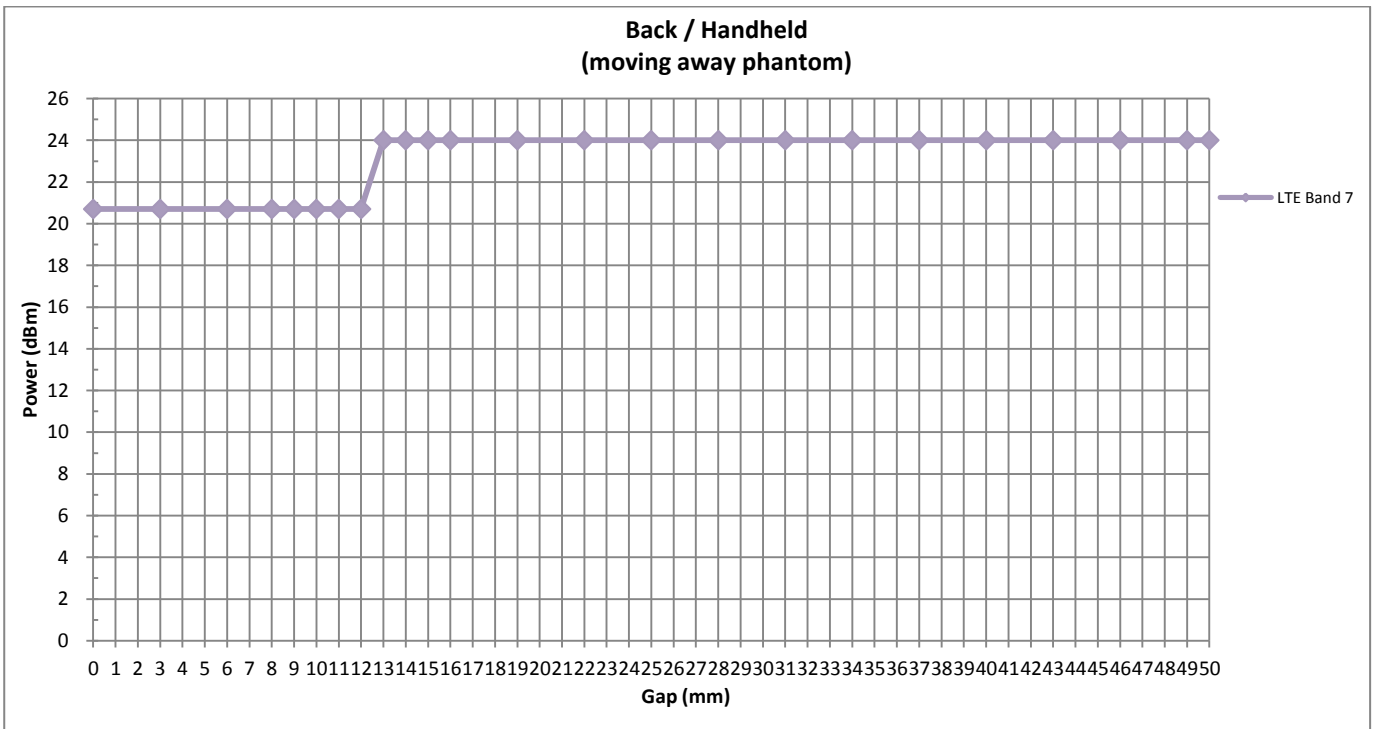
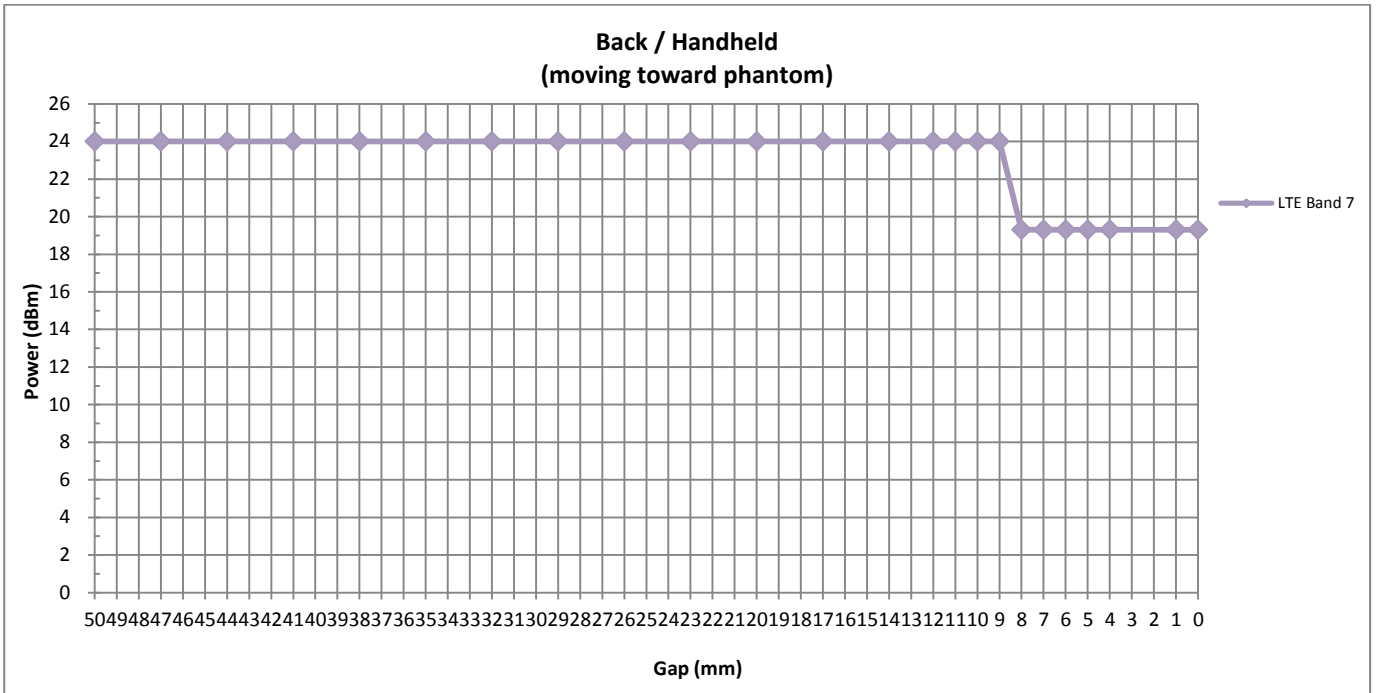

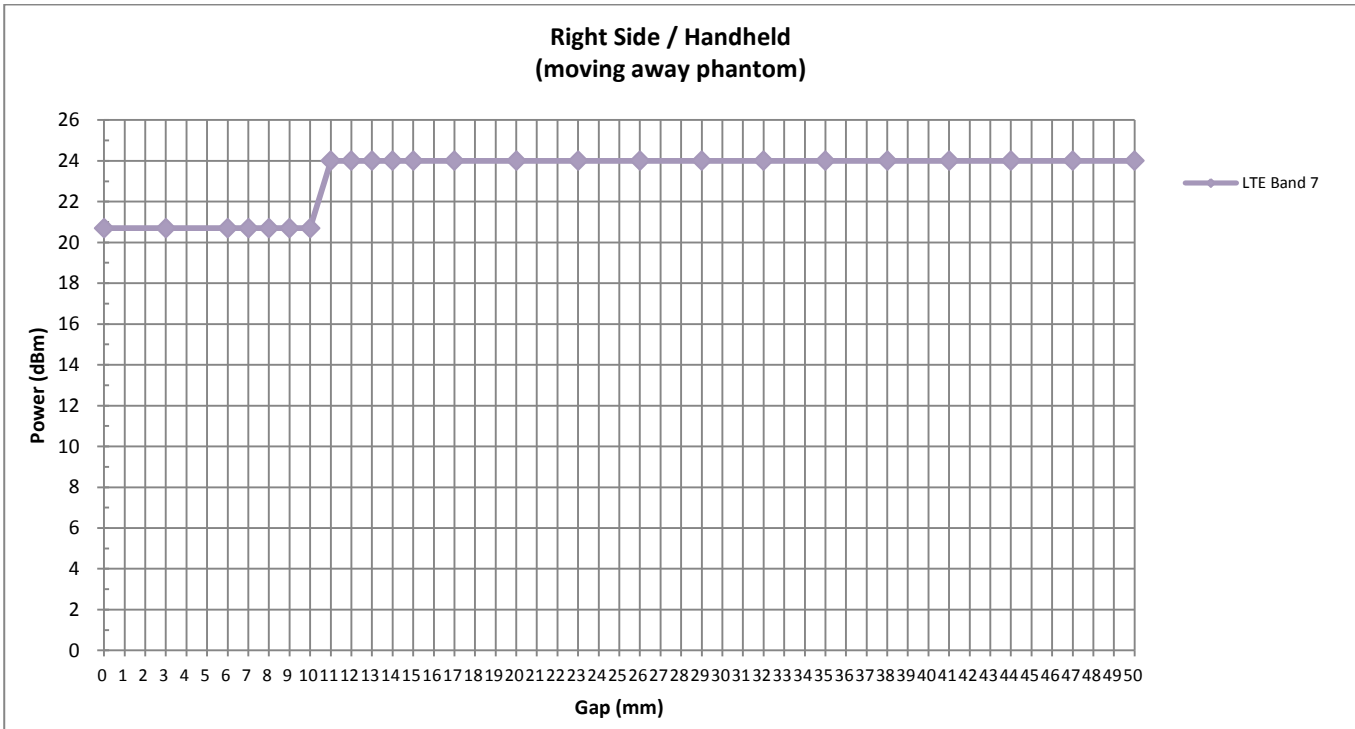
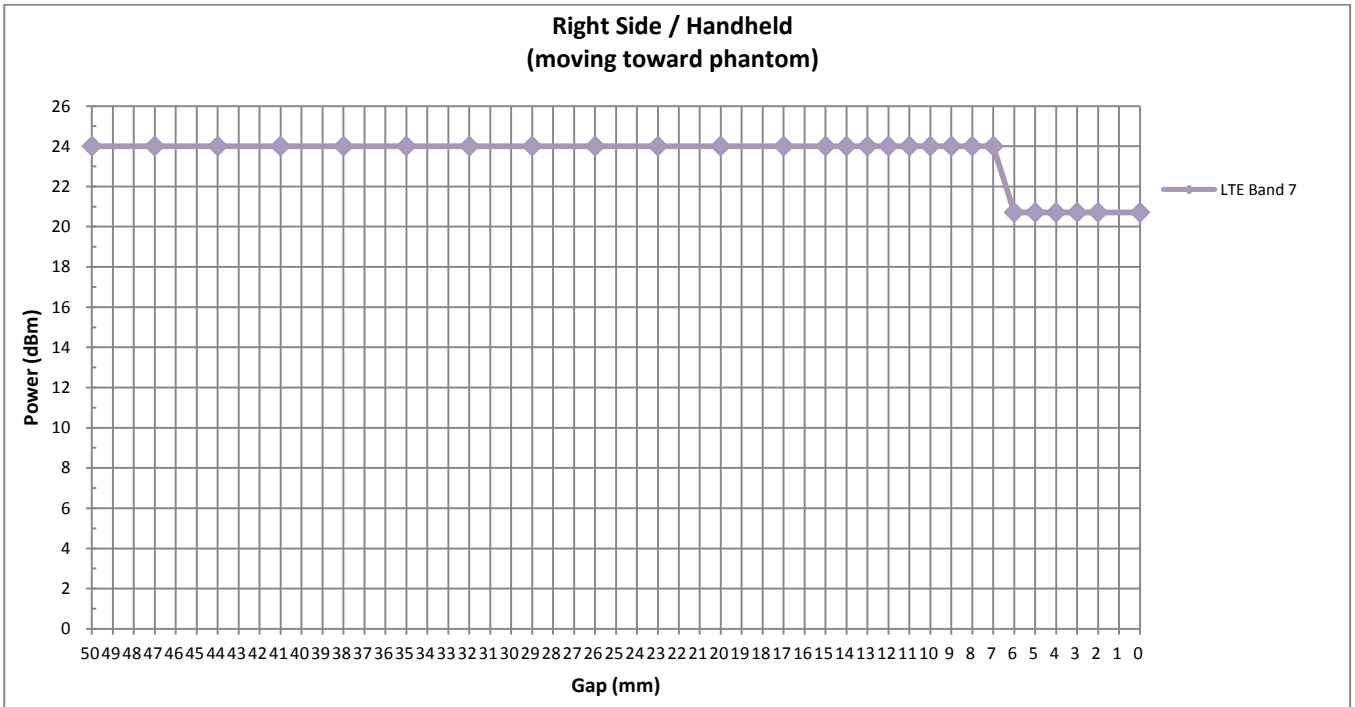





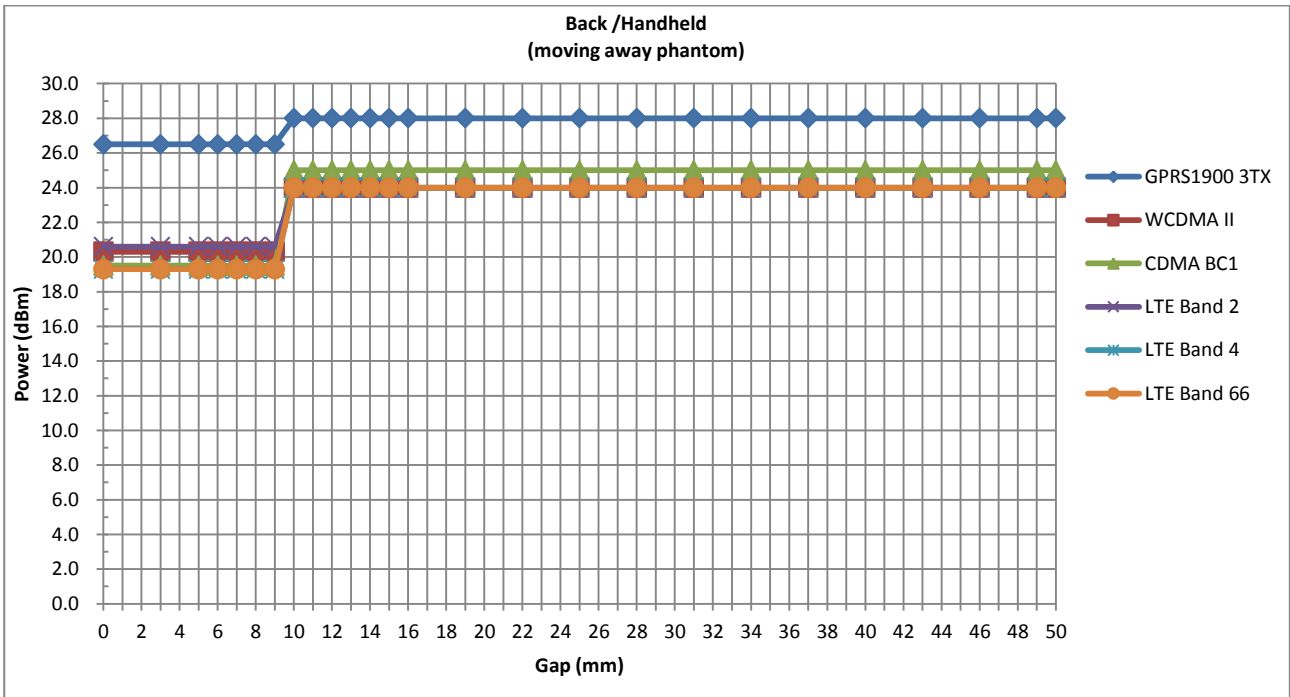
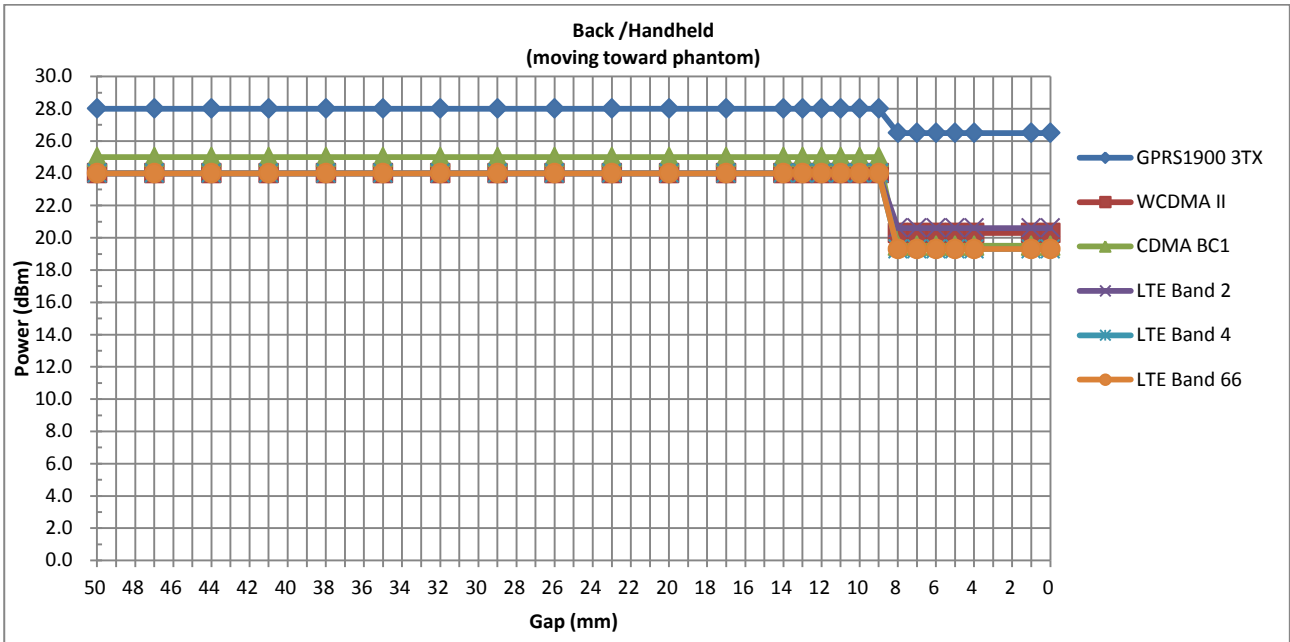

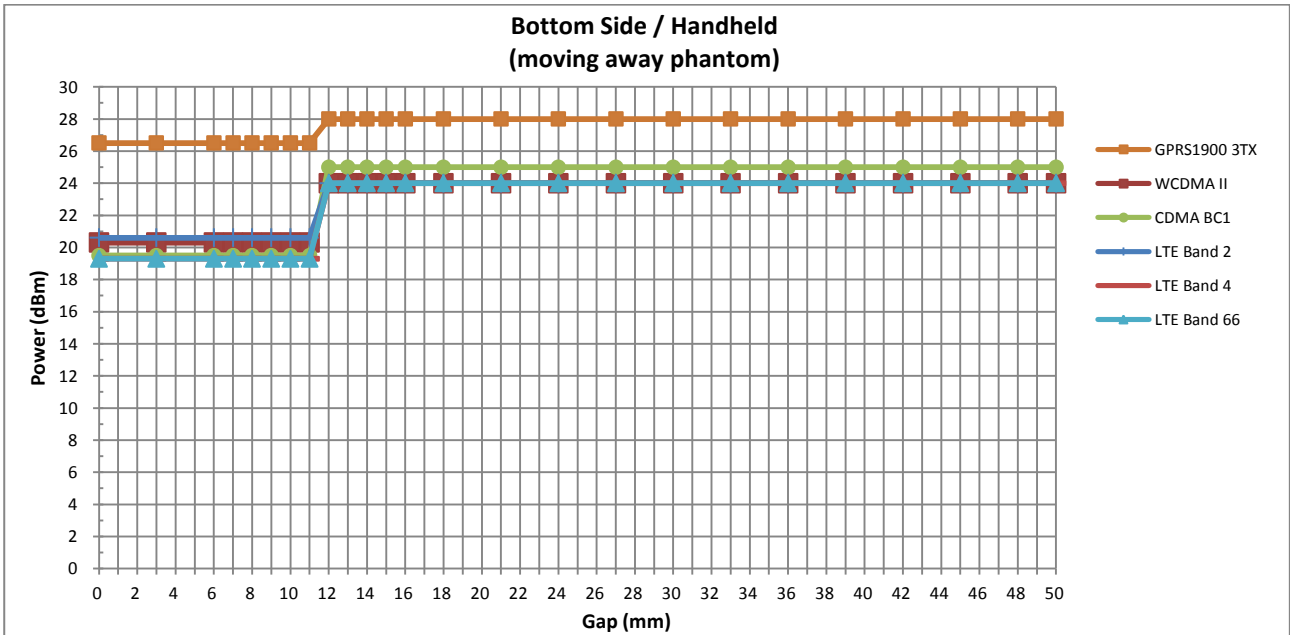
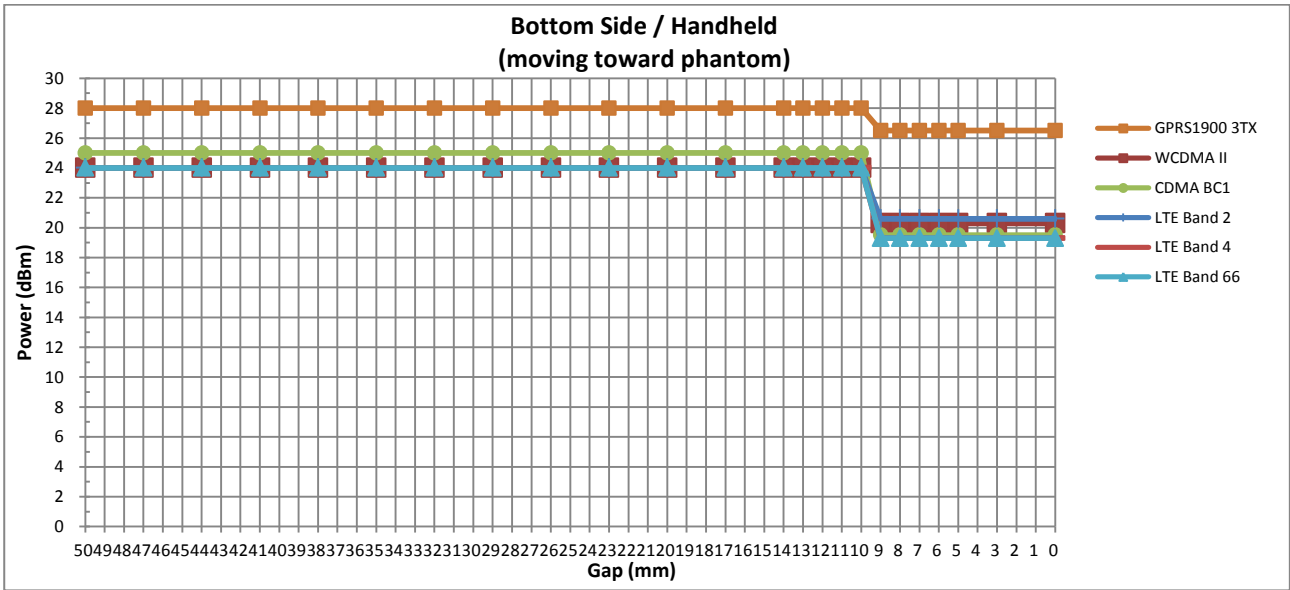

**5.2 Tilt angle influences to proximity sensor triggering(Per KDB616217 §6.4)**

The DUT was positioned directly below the flat phantom at the minimum measured trigger distance with bottom side parallel to the base of the flat phantom for each band.  
 The EUT was rotated about bottom side for angles up to +/- 45°. If the output power increased during the rotation the DUT was moved 1mm toward the phantom and the rotation repeated. This procedure was repeated until the power remained reduced for all angles up to +/- 45°.

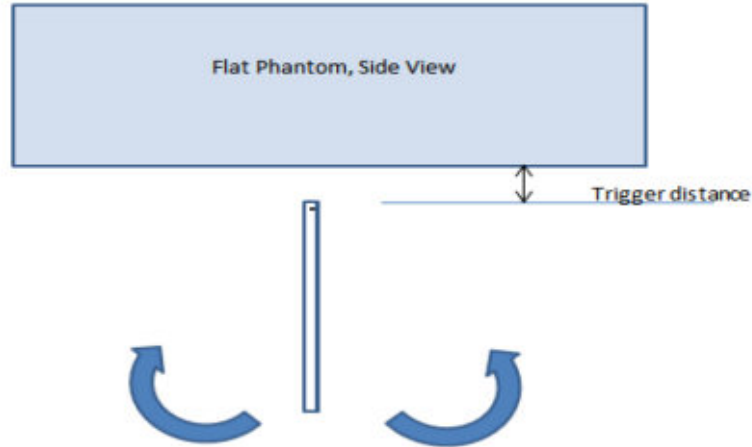

**Proximity Sensor Coverage Assesment(Right/Bottom Side)**

**Table: Summary of Tablet Tilt Angle Influence to Proximity Sensor Triggering (Right Side)**

Main ant Band(MHz)	Minimum trigger distance at which power reduction was maintained over ±45°	Power Reduction Status											
		-45°	-35°	-25°	-15°	-5°	0°	5°	15°	25°	35°	45°	
LTE Band 7	6mm	on	on	on	on	on	on	on	on	on	on	on	on

**Conclusion:** As is shown from the validation data, it can be ensured that the proximity sensor can be valid triggered for the DUT tilt coverage exposure condition.

**Table: Summary of Tablet Tilt Angle Influence to Proximity Sensor Triggering (Bottom Side)**

Main ant Band(MHz)	Minimum trigger distance at which power reduction was maintained over ±45°	Power Reduction Status											
		-45°	-35°	-25°	-15°	-5°	0°	5°	15°	25°	35°	45°	
GSM1900	9mm	on	on	on	on	on	on	on	on	on	on	on	on
WCDMA Band II	9mm	on	on	on	on	on	on	on	on	on	on	on	on
CDMA2000 BC1	9mm	on	on	on	on	on	on	on	on	on	on	on	on
LTE Band 2	9mm	on	on	on	on	on	on	on	on	on	on	on	on
LTE Band 4	9mm	on	on	on	on	on	on	on	on	on	on	on	on
LTE Band 66	9mm	on	on	on	on	on	on	on	on	on	on	on	on

**Conclusion:** As is shown from the validation data, it can be ensured that the proximity sensor can be valid triggered for the DUT tilt coverage exposure condition.

**6. RF Exposure Limits**

**6.1 Uncontrolled Environment**

Uncontrolled Environments are defined as locations where there is the exposure of individuals who have no knowledge or control of their exposure. The general population/uncontrolled exposure limits are applicable to situations in which the general public may be exposed or in which persons who are exposed as a consequence of their employment may not be made fully aware of the potential for exposure or cannot exercise control over their exposure. Members of the general public would come under this category when exposure is not employment-related; for example, in the case of a wireless transmitter that exposes persons in its vicinity.

**6.2 Controlled Environment**

Controlled Environments are defined as locations where there is exposure that may be incurred by persons who are aware of the potential for exposure, (i.e. as a result of employment or occupation). In general, occupational/controlled exposure limits are applicable to situations in which persons are exposed as a consequence of their employment, who have been made fully aware of the potential for exposure and can exercise control over their exposure. The exposure category is also applicable when the exposure is of a transient nature due to incidental passage through a location where the exposure levels may be higher than the general population/uncontrolled limits, but the exposed person is fully aware of the potential for exposure and can exercise control over his or her exposure by leaving the area or by some other appropriate means.

**Limits for Occupational/Controlled Exposure (W/kg)**

Whole-Body	Partial-Body	Hands, Wrists, Feet and Ankles
0.4	8.0	20.0

**Limits for General Population/Uncontrolled Exposure (W/kg)**

Whole-Body	Partial-Body	Hands, Wrists, Feet and Ankles
0.08	1.6	4.0

Whole-Body SAR is averaged over the entire body, partial-body SAR is averaged over any 1gram of tissue defined as a tissue volume in the shape of a cube. SAR for hands, wrists, feet and ankles is averaged over any 10 grams of tissue defined as a tissue volume in the shape of a cube.

## **7. Specific Absorption Rate (SAR)**

### **7.1 Introduction**

SAR is related to the rate at which energy is absorbed per unit mass in an object exposed to a radio field. The SAR distribution in a biological body is complicated and is usually carried out by experimental techniques or numerical modeling. The standard recommends limits for two tiers of groups, occupational/controlled and general population/uncontrolled, based on a person's awareness and ability to exercise control over his or her exposure. In general, occupational/controlled exposure limits are higher than the limits for general population/uncontrolled.

### **7.2 SAR Definition**

The SAR definition is the time derivative (rate) of the incremental energy (dW) absorbed by (dissipated in) an incremental mass (dm) contained in a volume element (dv) of a given density ( $\rho$ ). The equation description is as below:

$$\text{SAR} = \frac{d}{dt} \left( \frac{dW}{dm} \right) = \frac{d}{dt} \left( \frac{dW}{\rho dv} \right)$$

SAR is expressed in units of Watts per kilogram (W/kg)

$$\text{SAR} = \frac{\sigma |E|^2}{\rho}$$

Where:  $\sigma$  is the conductivity of the tissue,  $\rho$  is the mass density of the tissue and E is the RMS electrical field strength.

## 8. System Description and Setup

The DASY system used for performing compliance tests consists of the following items:

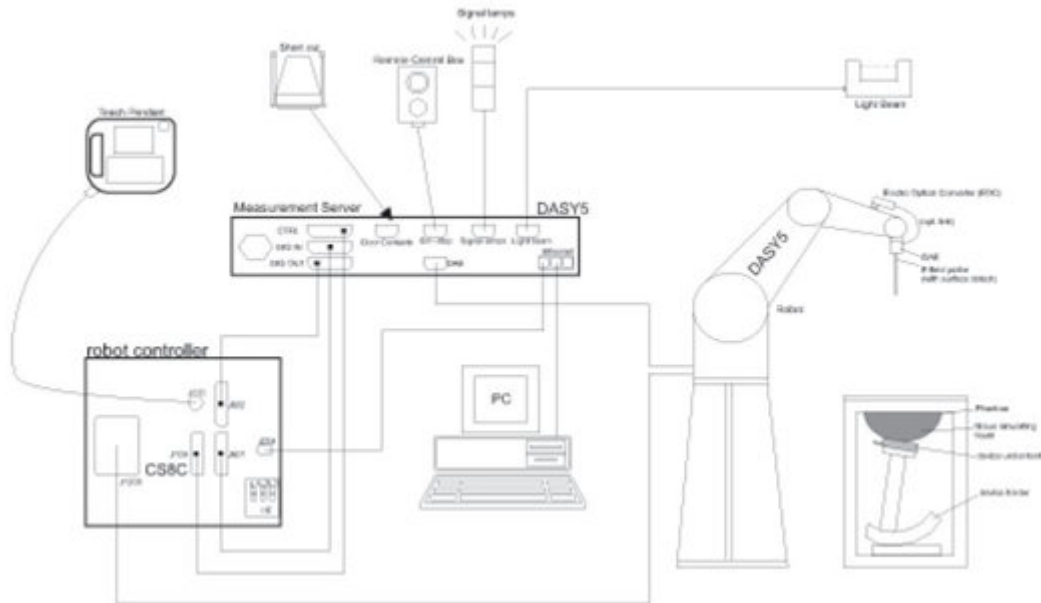

- A standard high precision 6-axis robot with controller, teach pendant and software. An arm extension for accommodating the data acquisition electronics (DAE).
- An isotropic Field probe optimized and calibrated for the targeted measurement.
- A data acquisition electronics (DAE) which performs the signal amplification, signal multiplexing, AD-conversion, offset measurements, mechanical surface detection, collision detection, etc. The unit is battery powered with standard or rechargeable batteries. The signal is optically transmitted to the EOC.
- The Electro-optical converter (EOC) performs the conversion from optical to electrical signals for the digital communication to the DAE. To use optical surface detection, a special version of the EOC is required. The EOC signal is transmitted to the measurement server.
- The function of the measurement server is to perform the time critical tasks such as signal filtering, control of the robot operation and fast movement interrupts.
- The Light Beam used is for probe alignment. This improves the (absolute) accuracy of the probe positioning.
- A computer running WinXP or Win7 and the DASY5 software.
- Remote control and teach pendant as well as additional circuitry for robot safety such as warning lamps, etc.
- The phantom, the device holder and other accessories according to the targeted measurement.

**8.1 E-Field Probe**

The SAR measurement is conducted with the dosimetric probe (manufactured by SPEAG).The probe is specially designed and calibrated for use in liquid with high permittivity. The dosimetric probe has special calibration in liquid at different frequency. This probe has a built in optical surface detection system to prevent from collision with phantom.

**<EX3DV4 Probe>**

Construction	Symmetric design with triangular core Built-in shielding against static charges PEEK enclosure material (resistant to organic solvents, e.g., DGBE)	
Frequency	10 MHz – >6 GHz Linearity: ±0.2 dB (30 MHz – 6 GHz)	
Directivity	±0.3 dB in TSL (rotation around probe axis) ±0.5 dB in TSL (rotation normal to probe axis)	
Dynamic Range	10 µW/g – >100 mW/g Linearity: ±0.2 dB (noise: typically <1 µW/g)	
Dimensions	Overall length: 337 mm (tip: 20 mm) Tip diameter: 2.5 mm (body: 12 mm) Typical distance from probe tip to dipole centers: 1 mm	

**8.2 Data Acquisition Electronics (DAE)**

The data acquisition electronics (DAE) consists of a highly sensitive electrometer-grade preamplifier with auto-zeroing, a channel and gain-switching multiplexer, a fast 16 bit AD-converter and a command decoder and control logic unit. Transmission to the measurement server is accomplished through an optical downlink for data and status information as well as an optical uplink for commands and the clock.

The input impedance of the DAE is 200 MOhm; the inputs are symmetrical and floating. Common mode rejection is above 80 dB.



Photo of DAE



**8.3 Phantom**

**<SAM Twin Phantom>**

Shell Thickness	2 ± 0.2 mm; Center ear point: 6 ± 0.2 mm
Filling Volume	Approx. 25 liters
Dimensions	Length: 1000 mm; Width: 500 mm; Height: adjustable feet
Measurement Areas	Left Hand, Right Hand, Flat Phantom



The bottom plate contains three pair of bolts for locking the device holder. The device holder positions are adjusted to the standard measurement positions in the three sections. A white cover is provided to tap the phantom during off-periods to prevent water evaporation and changes in the liquid parameters. On the phantom top, three reference markers are provided to identify the phantom position with respect to the robot.

**<ELI Phantom>**

Shell Thickness	2 ± 0.2 mm (sagging: <1%)
Filling Volume	Approx. 30 liters
Dimensions	Major ellipse axis: 600 mm Minor axis: 400 mm

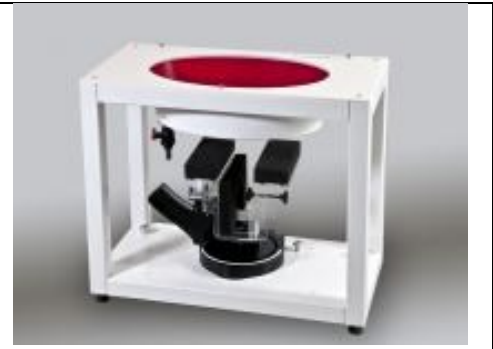

The ELI phantom is intended for compliance testing of handheld and body-mounted wireless devices in the frequency range of 30 MHz to 6 GHz. ELI4 is fully compatible with standard and all known tissue simulating liquids.

## 8.4 Device Holder

### <Mounting Device for Hand-Held Transmitter>

In combination with the Twin SAM V5.0/V5.0c or ELI phantoms, the Mounting Device for Hand-Held Transmitters enables rotation of the mounted transmitter device to specified spherical coordinates. At the heads, the rotation axis is at the ear opening. Transmitter devices can be easily and accurately positioned according to IEC 62209-1, IEEE 1528, FCC, or other specifications. The device holder can be locked for positioning at different phantom sections (left head, right head, flat). And upgrade kit to Mounting Device to enable easy mounting of wider devices like big smart-phones, e-books, small tablets, etc. It holds devices with width up to 140 mm.



Mounting Device for Hand-Held Transmitters



Mounting Device Adaptor for Wide-Phones

### <Mounting Device for Laptops and other Body-Worn Transmitters>

The extension is lightweight and made of POM, acrylic glass and foam. It fits easily on the upper part of the mounting device in place of the phone positioned. The extension is fully compatible with the SAM Twin and ELI phantoms.



Mounting Device for Laptops

## 9. Measurement Procedures

The measurement procedures are as follows:

### <Conducted power measurement>

- (a) For WWAN power measurement, use base station simulator to configure EUT WWAN transmission in conducted connection with RF cable, at maximum power in each supported wireless interface and frequency band.
- (b) Read the WWAN RF power level from the base station simulator.
- (c) For WLAN/BT power measurement, use engineering software to configure EUT WLAN/BT continuously transmission, at maximum RF power in each supported wireless interface and frequency band
- (d) Connect EUT RF port through RF cable to the power meter, and measure WLAN/BT output power

### <SAR measurement>

- (a) Use base station simulator to configure EUT WWAN transmission in radiated connection, and engineering software to configure EUT WLAN/BT continuously transmission, at maximum RF power, in the highest power channel.
- (b) Place the EUT in the positions as Appendix D demonstrates.
- (c) Set scan area, grid size and other setting on the DASY software.
- (d) Measure SAR results for the highest power channel on each testing position.
- (e) Find out the largest SAR result on these testing positions of each band
- (f) Measure SAR results for other channels in worst SAR testing position if the reported SAR of highest power channel is larger than 0.8 W/kg

According to the test standard, the recommended procedure for assessing the peak spatial-average SAR value consists of the following steps:

- (a) Power reference measurement
- (b) Area scan
- (c) Zoom scan
- (d) Power drift measurement

### 9.1 Spatial Peak SAR Evaluation

The procedure for spatial peak SAR evaluation has been implemented according to the test standard. It can be conducted for 1g and 10g, as well as for user-specific masses. The DASY software includes all numerical procedures necessary to evaluate the spatial peak SAR value.

The base for the evaluation is a "cube" measurement. The measured volume must include the 1g and 10g cubes with the highest averaged SAR values. For that purpose, the center of the measured volume is aligned to the interpolated peak SAR value of a previously performed area scan.

The entire evaluation of the spatial peak values is performed within the post-processing engine (SEMCAD). The system always gives the maximum values for the 1g and 10g cubes. The algorithm to find the cube with highest averaged SAR is divided into the following stages:

- (a) Extraction of the measured data (grid and values) from the Zoom Scan
- (b) Calculation of the SAR value at every measurement point based on all stored data (A/D values and measurement parameters)
- (c) Generation of a high-resolution mesh within the measured volume
- (d) Interpolation of all measured values from the measurement grid to the high-resolution grid
- (e) Extrapolation of the entire 3-D field distribution to the phantom surface over the distance from sensor to surface
- (f) Calculation of the averaged SAR within masses of 1g and 10g

**9.2 Power Reference Measurement**

The Power Reference Measurement and Power Drift Measurements are for monitoring the power drift of the device under test in the batch process. The minimum distance of probe sensors to surface determines the closest measurement point to phantom surface. This distance cannot be smaller than the distance of sensor calibration points to probe tip as defined in the probe properties.

**9.3 Area Scan**

The area scan is used as a fast scan in two dimensions to find the area of high field values, before doing a fine measurement around the hot spot. The sophisticated interpolation routines implemented in DASY software can find the maximum found in the scanned area, within a range of the global maximum. The range (in dB0 is specified in the standards for compliance testing. For example, a 2 dB range is required in IEEE standard 1528 and IEC 62209 standards, whereby 3 dB is a requirement when compliance is assessed in accordance with the ARIB standard (Japan), if only one zoom scan follows the area scan, then only the absolute maximum will be taken as reference. For cases where multiple maximums are detected, the number of zoom scans has to be increased accordingly.

Area scan parameters extracted from FCC KDB 865664 D01v01r04 SAR measurement 100 MHz to 6 GHz.

	≤ 3 GHz	> 3 GHz
Maximum distance from closest measurement point (geometric center of probe sensors) to phantom surface	5 ± 1 mm	$\frac{1}{2} \cdot \delta \cdot \ln(2) \pm 0.5$ mm
Maximum probe angle from probe axis to phantom surface normal at the measurement location	30° ± 1°	20° ± 1°
Maximum area scan spatial resolution: $\Delta x_{Area}, \Delta y_{Area}$	≤ 2 GHz: ≤ 15 mm 2 – 3 GHz: ≤ 12 mm	3 – 4 GHz: ≤ 12 mm 4 – 6 GHz: ≤ 10 mm
	When the x or y dimension of the test device, in the measurement plane orientation, is smaller than the above, the measurement resolution must be ≤ the corresponding x or y dimension of the test device with at least one measurement point on the test device.	

**9.4 Zoom Scan**

Zoom scans are used assess the peak spatial SAR values within a cubic averaging volume containing 1 gram and 10 gram of simulated tissue. The zoom scan measures points (refer to table below) within a cube shoes base faces are centered on the maxima found in a preceding area scan job within the same procedure. When the measurement is done, the zoom scan evaluates the averaged SAR for 1 gram and 10 gram and displays these values next to the job's label.

Zoom scan parameters extracted from FCC KDB 865664 D01v01r04 SAR measurement 100 MHz to 6 GHz.

		≤ 3 GHz	> 3 GHz	
Maximum zoom scan spatial resolution: $\Delta x_{Zoom}, \Delta y_{Zoom}$		$\leq 2$ GHz: $\leq 8$ mm 2 – 3 GHz: $\leq 5$ mm*	3 – 4 GHz: $\leq 5$ mm* 4 – 6 GHz: $\leq 4$ mm*	
Maximum zoom scan spatial resolution, normal to phantom surface	uniform grid: $\Delta z_{Zoom}(n)$	$\leq 5$ mm	3 – 4 GHz: $\leq 4$ mm 4 – 5 GHz: $\leq 3$ mm 5 – 6 GHz: $\leq 2$ mm	
	graded grid	$\Delta z_{Zoom}(1)$ : between 1 <sup>st</sup> two points closest to phantom surface	$\leq 4$ mm	3 – 4 GHz: $\leq 3$ mm 4 – 5 GHz: $\leq 2.5$ mm 5 – 6 GHz: $\leq 2$ mm
		$\Delta z_{Zoom}(n>1)$ : between subsequent points	$\leq 1.5 \cdot \Delta z_{Zoom}(n-1)$	
Minimum zoom scan volume	x, y, z	$\geq 30$ mm	3 – 4 GHz: $\geq 28$ mm 4 – 5 GHz: $\geq 25$ mm 5 – 6 GHz: $\geq 22$ mm	
Note: $\delta$ is the penetration depth of a plane-wave at normal incidence to the tissue medium; see draft standard IEEE P1528-2011 for details. * When zoom scan is required and the <i>reported</i> SAR from the <i>area scan based 1-g SAR estimation</i> procedures of KDB 447498 is $\leq 1.4$ W/kg, $\leq 8$ mm, $\leq 7$ mm and $\leq 5$ mm zoom scan resolution may be applied, respectively, for 2 GHz to 3 GHz, 3 GHz to 4 GHz and 4 GHz to 6 GHz.				

**9.5 Volume Scan Procedures**

The volume scan is used for assess overlapping SAR distributions for antennas transmitting in different frequency bands. It is equivalent to an oversized zoom scan used in standalone measurements. The measurement volume will be used to enclose all the simultaneous transmitting antennas. For antennas transmitting simultaneously in different frequency bands, the volume scan is measured separately in each frequency band. In order to sum correctly to compute the 1g aggregate SAR, the EUT remain in the same test position for all measurements and all volume scan use the same spatial resolution and grid spacing. When all volume scan were completed, the software, SEMCAD postprocessor can combine and subsequently superpose these measurement data to calculating the multiband SAR.

**9.6 Power Drift Monitoring**

All SAR testing is under the EUT install full charged battery and transmit maximum output power. In DASy measurement software, the power reference measurement and power drift measurement procedures are used for monitoring the power drift of EUT during SAR test. Both these procedures measure the field at a specified reference position before and after the SAR testing. The software will calculate the field difference in dB. If the power drifts more than 5%, the SAR will be retested.



**10. Test Equipment List**

Manufacturer	Name of Equipment	Type/Model	Serial Number	Calibration	
				Last Cal.	Due Date
SPEAG	750MHz System Validation Kit	D750V3	1065	2017/12/4	2018/12/3
SPEAG	835MHz System Validation Kit	D835V2	4d091	2017/12/5	2018/12/4
SPEAG	1750MHz System Validation Kit	D1750V2	1069	2017/12/5	2018/12/4
SPEAG	1900MHz System Validation Kit	D1900V2	5d118	2017/12/6	2018/12/5
SPEAG	2450MHz System Validation Kit	D2450V2	840	2017/12/7	2018/12/6
SPEAG	2600MHz System Validation Kit	D2600V2	1061	2017/12/7	2018/12/6
SPEAG	5000MHz System Validation Kit	D5GHzV2	1006	2017/9/26	2018/9/25
SPEAG	Data Acquisition Electronics	DAE4	1279	2018/1/3	2019/1/2
SPEAG	Data Acquisition Electronics	DAE4	1210	2018/5/28	2019/5/27
SPEAG	Dosimetric E-Field Probe	EX3DV4	3954	2018/1/31	2019/1/30
SPEAG	Dosimetric E-Field Probe	EX3DV4	3857	2018/5/31	2019/5/30
SPEAG	SAM Twin Phantom	QD 000 P40 CB	TP-1842	NCR	NCR
SPEAG	SAM Twin Phantom	QD 000 P40 CB	TP-1839	NCR	NCR
SPEAG	SAM Twin Phantom	QD 000 P40 CB	TP-1164	NCR	NCR
SPEAG	SAM Twin Phantom	QD 000 P40 CB	TP-1542	NCR	NCR
SPEAG	Phone Positioner	N/A	N/A	NCR	NCR
Anritsu	Radio communication analyzer	MT8820C	6201563814	2018/1/18	2019/1/17
Anritsu	Radio communication analyzer	MT8821C	6201432831	2018/4/11	2019/4/10
Agilent	Wireless Communication Test Set	E5515C	MY52102706	2018/4/17	2019/4/16
Agilent	ENA Series Network Analyzer	E5071C	MY46111157	2018/4/17	2019/4/16
SPEAG	DAK Kit	DAK3.5	1146	2017/7/18	2018/7/17
SPEAG	Dielectric Probe Kit	DAK-3.5	1138	2017/11/28	2018/11/27
R&S	Signal Generator	SML03	103818	2017/8/17	2018/8/16
Anritsu	Power Meter	ML2495A	1419002	2018/5/14	2019/5/13
Anritsu	Power Sensor	MA2411B	1339124	2018/5/14	2019/5/13
Anritsu	Power Meter	ML2495A	1218006	2017/10/6	2018/10/5
Anritsu	Power Sensor	MA2411B	1207363	2017/10/6	2018/10/5
R&S	CBT BLUETOOTH TESTER	CBT	100783	2017/8/8	2018/8/7
EXA	Spectrum Analyzer	FSV7	101742	2018/1/19	2019/1/18
Testo	Hygrometer	608-H1	1241332096	2017/8/21	2018/8/20
FLUKE	DIGITAC THERMOMETER	51II	97240029	2017/8/3	2018/8/2
ARRA	Power Divider	A3200-2	N/A		Note
MCL	Attenuation1	BW-S10W5+	N/A		Note
MCL	Attenuation2	BW-S10W5+	N/A		Note
MCL	Attenuation3	BW-S10W5+	N/A		Note
Agilent	Dual Directional Coupler	778D	50422		Note
PASTERNAK	Dual Directional Coupler	PE2214-10	N/A		Note
AR	Amplifier	5S1G4	333096		Note
mini-circuits	Amplifier	ZVE-3W-83+	162601250		Note

**Note:** Prior to system verification and validation, the path loss from the signal generator to the system check source and the power meter, which includes the amplifier, cable, attenuator and directional coupler, was measured by the network analyzer. The reading of the power meter was offset by the path loss difference between the path to the power meter and the path to the system check source to monitor the actual power level fed to the system check source.

## 11. System Verification

### 11.1 Tissue Simulating Liquids

For the measurement of the field distribution inside the SAM phantom with DASY, the phantom must be filled with around 25 liters of homogeneous body tissue simulating liquid. For head SAR testing, the liquid height from the ear reference point (ERP) of the phantom to the liquid top surface is larger than 15 cm, which is shown in Fig. 10.1. For body SAR testing, the liquid height from the center of the flat phantom to the liquid top surface is larger than 15 cm, which is shown in Fig. 10.2.

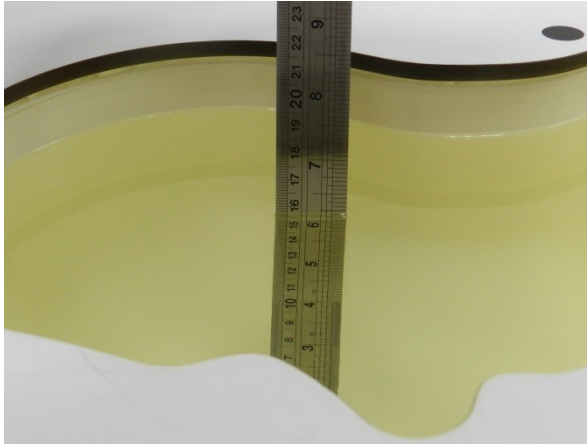

Fig 11.1 Photo of Liquid Height for Head SAR

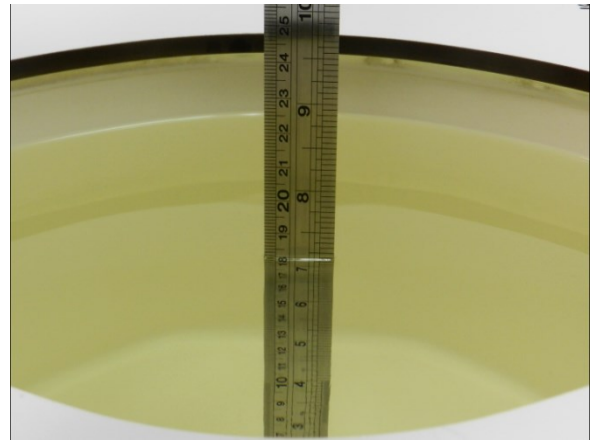

Fig 11.2 Photo of Liquid Height for Body SAR

**11.2 Tissue Verification**

The following tissue formulations are provided for reference only as some of the parameters have not been thoroughly verified. The composition of ingredients may be modified accordingly to achieve the desired target tissue parameters required for routine SAR evaluation.

Frequency (MHz)	Water (%)	Sugar (%)	Cellulose (%)	Salt (%)	Preventol (%)	DGBE (%)	Conductivity (σ)	Permittivity (ε <sub>r</sub> )
<b>For Head</b>								
750	41.1	57.0	0.2	1.4	0.2	0	0.89	41.9
835	40.3	57.9	0.2	1.4	0.2	0	0.90	41.5
1800, 1900, 2000	55.2	0	0	0.3	0	44.5	1.40	40.0
2450	55.0	0	0	0	0	45.0	1.80	39.2
2600	54.8	0	0	0.1	0	45.1	1.96	39.0
<b>For Body</b>								
750	51.7	47.2	0	0.9	0.1	0	0.96	55.5
835	50.8	48.2	0	0.9	0.1	0	0.97	55.2
1800, 1900, 2000	70.2	0	0	0.4	0	29.4	1.52	53.3
2450	68.6	0	0	0	0	31.4	1.95	52.7
2600	68.1	0	0	0.1	0	31.8	2.16	52.5

**Simulating Liquid for 5GHz, Manufactured by SPEAG**

Ingredients	(% by weight)
Water	64~78%
Mineral oil	11~18%
Emulsifiers	9~15%
Additives and Salt	2~3%

**<Tissue Dielectric Parameter Check Results>**

Frequency (MHz)	Tissue Type	Liquid Temp. (°C)	Conductivity (σ)	Permittivity (ε <sub>r</sub> )	Conductivity Target (σ)	Permittivity Target (ε <sub>r</sub> )	Delta (σ) (%)	Delta (ε <sub>r</sub> ) (%)	Limit (%)	Date
750	Head	22.6	0.912	42.825	0.89	41.90	2.47	2.21	±5	2018/5/20
835	Head	22.6	0.908	42.198	0.90	41.50	0.89	1.68	±5	2018/5/20
1750	Head	22.7	1.325	39.218	1.37	40.10	-3.28	-2.20	±5	2018/5/20
1900	Head	22.8	1.400	40.573	1.40	40.00	0.00	1.43	±5	2018/5/19
2450	Head	22.7	1.823	38.343	1.80	39.20	1.28	-2.19	±5	2018/5/27
2600	Head	22.8	1.997	37.741	1.96	39.00	1.89	-3.23	±5	2018/5/21
5250	Head	22.7	4.865	37.109	4.71	35.90	3.29	3.37	±5	2018/5/24
5600	Head	22.8	5.207	36.587	5.07	35.50	2.70	3.06	±5	2018/5/25
5750	Head	22.9	5.361	36.365	5.22	35.40	2.70	2.73	±5	2018/5/25
750	Body	22.8	0.968	56.659	0.96	55.50	0.83	2.09	±5	2018/5/17
835	Body	22.8	0.972	55.162	0.97	55.20	0.21	-0.07	±5	2018/5/17
1750	Body	22.7	1.443	54.693	1.49	53.40	-3.15	2.42	±5	2018/5/21
1900	Body	22.8	1.514	52.808	1.52	53.30	-0.39	-0.92	±5	2018/5/21
1750	Body	22.6	1.472	52.961	1.49	53.40	-1.21	-0.82	±5	2018/7/30
1900	Body	22.6	1.537	53.469	1.52	53.30	1.12	0.32	±5	2018/7/28
2450	Body	22.6	1.976	53.443	1.95	52.70	1.33	1.41	±5	2018/5/27
2600	Body	22.8	2.186	52.894	2.16	52.50	1.20	0.75	±5	2018/5/18
5250	Body	22.7	5.506	47.956	5.36	48.90	2.72	-1.93	±5	2018/5/23
5600	Body	22.8	5.954	47.367	5.77	48.50	3.19	-2.34	±5	2018/5/23
5750	Body	22.9	6.154	47.115	5.94	48.30	3.60	-2.45	±5	2018/5/24



**11.3 System Performance Check Results**

Comparing to the original SAR value provided by SPEAG, the verification data should be within its specification of 10 %. Below table shows the target SAR and measured SAR after normalized to 1W input power. The table below indicates the system performance check can meet the variation criterion and the plots can be referred to Appendix A of this report.

**<1g SAR>**

Date	Frequency (MHz)	Tissue Type	Input Power (mW)	Dipole S/N	Probe S/N	DAE S/N	Measured 1g SAR (W/kg)	Targeted 1g SAR (W/kg)	Normalized 1g SAR (W/kg)	Deviation (%)
2018/5/20	750	Head	250	1065	3954	1279	2.11	8.33	8.44	1.32
2018/5/20	835	Head	250	4d091	3954	1279	2.32	9.48	9.28	-2.11
2018/5/20	1750	Head	250	1069	3954	1279	8.62	37.00	34.48	-6.81
2018/5/19	1900	Head	250	5d118	3954	1279	9.05	39.70	36.20	-8.82
2018/5/27	2450	Head	250	840	3954	1279	12.20	52.60	48.80	-7.22
2018/5/21	2600	Head	250	1061	3954	1279	13.23	58.20	52.92	-9.07
2018/5/24	5250	Head	100	1006	3954	1279	7.68	78.30	76.80	-1.92
2018/5/25	5600	Head	100	1006	3954	1279	7.89	85.00	78.90	-7.18
2018/5/25	5750	Head	100	1006	3954	1279	7.31	78.50	73.10	-6.88
2018/5/17	750	Body	250	1065	3954	1279	2.13	8.72	8.52	-2.29
2018/5/17	835	Body	250	4d091	3954	1279	2.47	9.72	9.88	1.65
2018/5/21	1750	Body	250	1069	3954	1279	8.72	38.00	34.88	-8.21
2018/5/21	1900	Body	250	5d118	3954	1279	10.20	40.40	40.80	0.99
2018/7/30	1750	Body	250	1069	3857	1210	9.23	38.00	36.92	-2.84
2018/7/28	1900	Body	250	5d118	3857	1210	9.75	40.40	39.00	-3.47
2018/5/27	2450	Body	250	840	3954	1279	12.20	51.90	48.80	-5.97
2018/5/18	2600	Body	250	1061	3954	1279	14.40	56.40	57.60	2.13
2018/5/23	5250	Body	100	1006	3954	1279	7.53	77.00	75.30	-2.21
2018/5/23	5600	Body	100	1006	3954	1279	7.62	80.10	76.20	-4.87
2018/5/24	5750	Body	100	1006	3954	1279	7.45	75.10	74.50	-0.80

**<10g SAR>**

Date	Frequency (MHz)	Tissue Type	Input Power (mW)	Dipole S/N	Probe S/N	DAE S/N	Measured 10g SAR (W/kg)	Targeted 10g SAR (W/kg)	Normalized 10g SAR (W/kg)	Deviation (%)
2018/5/17	750	Body	250	1065	3954	1279	1.53	5.76	6.12	6.25
2018/5/17	835	Body	250	4d091	3954	1279	1.73	6.42	6.92	7.79
2018/5/21	1750	Body	250	1069	3954	1279	4.86	20.30	19.44	-4.24
2018/5/21	1900	Body	250	5d118	3954	1279	5.54	21.10	22.16	5.02
2018/5/18	2600	Body	250	1061	3954	1279	6.67	25.00	26.68	6.72
2018/5/23	5250	Body	100	1006	3954	1279	2.15	21.30	21.50	0.94
2018/5/23	5600	Body	100	1006	3954	1279	2.21	22.40	22.10	-1.34

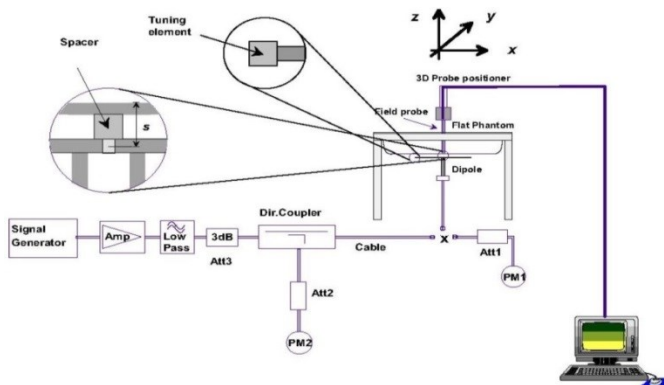

**Fig 11.3.1 System Performance Check Setup**



**Fig 11.3.2 Setup Photo**

## 12. RF Exposure Positions

### 12.1 Ear and handset reference point

Figure 12.1.1 shows the front, back, and side views of the SAM phantom. The center-of-mouth reference point is labeled "M," the left ear reference point (ERP) is marked "LE," and the right ERP is marked "RE." Each ERP is 15 mm along the B-M (back-mouth) line behind the entrance-to-ear-canal (EEC) point, as shown in Figure 12.1.2 The Reference Plane is defined as passing through the two ear reference points and point M. The line N-F (neck-front), also called the reference pivoting line, is normal to the Reference Plane and perpendicular to both a line passing through RE and LE and the B-M line (see Figure 12.1.3). Both N-F and B-M lines should be marked on the exterior of the phantom shell to facilitate handset positioning. Posterior to the N-F line the ear shape is a flat surface with 6 mm thickness at each ERP, and forward of the N-F line the ear is truncated, as illustrated in Figure 12.1.2. The ear truncation is introduced to preclude the ear lobe from interfering with handset tilt, which could lead to unstable positioning at the cheek.

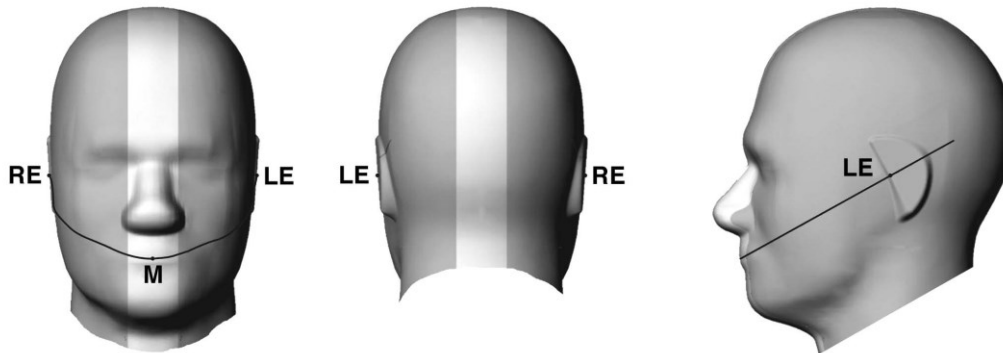

Fig 12.1.1 Front, back, and side views of SAM twin phantom

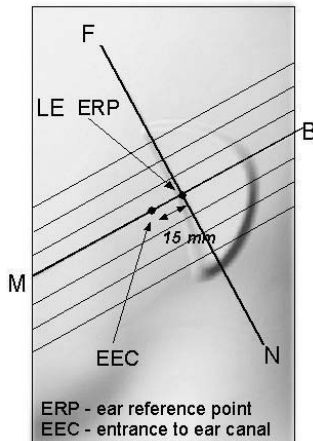

Fig 12.1.2 Close-up side view of phantom showing the ear region.

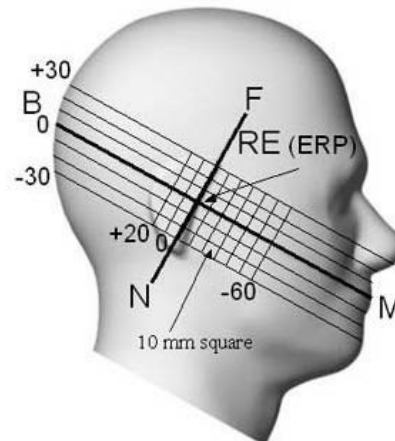

Fig 12.1.3 Side view of the phantom showing relevant markings and seven cross-sectional plane locations

## 12.2 Definition of the cheek position

1. Ready the handset for talk operation, if necessary. For example, for handsets with a cover piece (flip cover), open the cover. If the handset can transmit with the cover closed, both configurations must be tested.
2. Define two imaginary lines on the handset—the vertical centerline and the horizontal line. The vertical centerline passes through two points on the front side of the handset—the midpoint of the width  $w_t$  of the handset at the level of the acoustic output (point A in Figure 12.2.1 and Figure 12.2.2), and the midpoint of the width  $w_b$  of the bottom of the handset (point B). The horizontal line is perpendicular to the vertical centerline and passes through the center of the acoustic output (see Figure 12.2.1). The two lines intersect at point A. Note that for many handsets, point A coincides with the center of the acoustic output; however, the acoustic output may be located elsewhere on the horizontal line. Also note that the vertical centerline is not necessarily parallel to the front face of the handset (see Figure 12.2.2), especially for clamshell handsets, handsets with flip covers, and other irregularly-shaped handsets.
3. Position the handset close to the surface of the phantom such that point A is on the (virtual) extension of the line passing through points RE and LE on the phantom (see Figure 12.2.3), such that the plane defined by the vertical centerline and the horizontal line of the handset is approximately parallel to the sagittal plane of the phantom.
4. Translate the handset towards the phantom along the line passing through RE and LE until handset point A touches the pinna at the ERP.
5. While maintaining the handset in this plane, rotate it around the LE-RE line until the vertical centerline is in the plane normal to the plane containing B-M and N-F lines, i.e., the Reference Plane.
6. Rotate the handset around the vertical centerline until the handset (horizontal line) is parallel to the N-F line.
7. While maintaining the vertical centerline in the Reference Plane, keeping point A on the line passing through RE and LE, and maintaining the handset contact with the pinna, rotate the handset about the N-F line until any point on the handset is in contact with a phantom point below the pinna on the cheek. See Figure 12.2.3. The actual rotation angles should be documented in the test report.

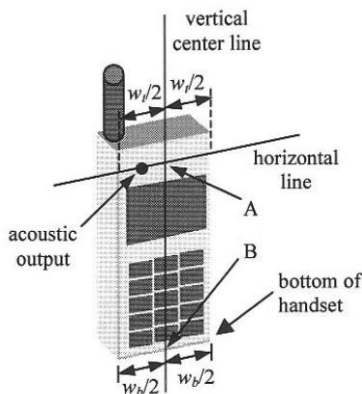

Fig 12.2.1 Handset vertical and horizontal reference lines—“fixed case”

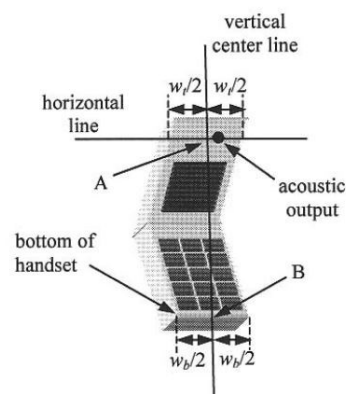

Fig 12.2.2 Handset vertical and horizontal reference lines—“clam-shell case”

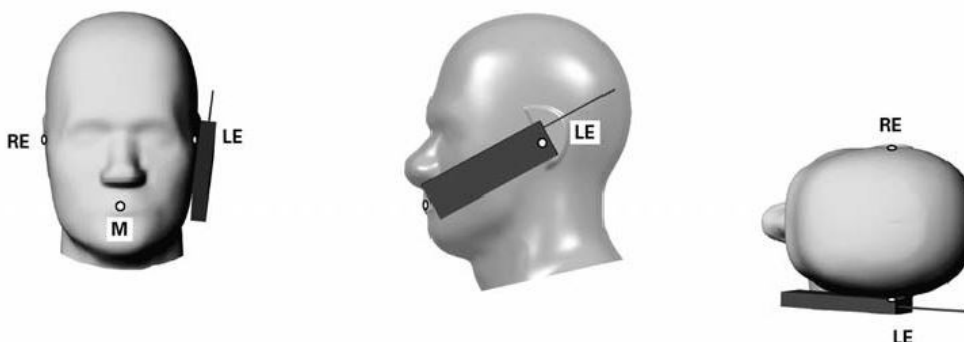
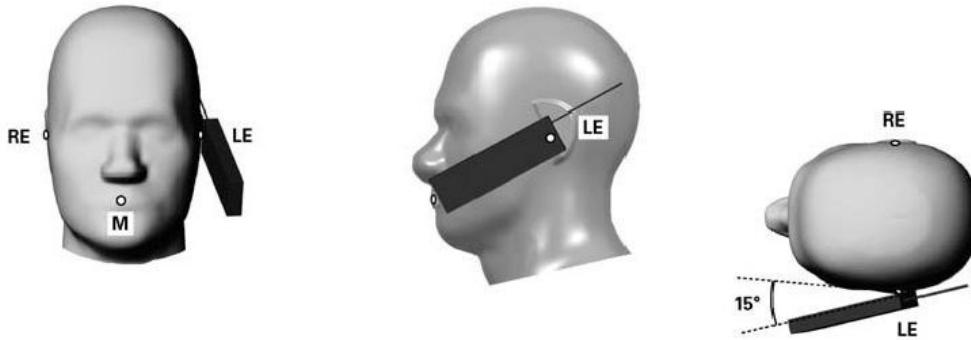

Fig 12.2.3 cheek or touch position. The reference points for the right ear (RE), left ear (LE), and mouth (M), which establish the Reference Plane for handset positioning, are indicated.

**12.3 Definition of the tilt position**

1. Ready the handset for talk operation, if necessary. For example, for handsets with a cover piece (flip cover), open the cover. If the handset can transmit with the cover closed, both configurations must be tested.
2. While maintaining the orientation of the handset, move the handset away from the pinna along the line passing through RE and LE far enough to allow a rotation of the handset away from the cheek by 15°.
3. Rotate the handset around the horizontal line by 15°.
4. While maintaining the orientation of the handset, move the handset towards the phantom on the line passing through RE and LE until any part of the handset touches the ear. The tilt position is obtained when the contact point is on the pinna. See Figure 12.3.1. If contact occurs at any location other than the pinna, e.g., the antenna at the back of the phantom head, the angle of the handset should be reduced. In this case, the tilt position is obtained if any point on the handset is in contact with the pinna and a second point



**Fig 12.3.1 Tilt position. The reference points for the right ear (RE), left ear (LE), and mouth (M), which define the Reference Plane for handset positioning, are indicated.**

## 12.4 Body Worn Accessory

Body-worn operating configurations are tested with the belt-clips and holsters attached to the device and positioned against a flat phantom in a normal use configuration (see Figure 12.4). Per KDB648474 D04v01r03, body-worn accessory exposure is typically related to voice mode operations when handsets are carried in body-worn accessories. The body-worn accessory procedures in FCC KDB 447498 D01v06 should be used to test for body-worn accessory SAR compliance, without a headset connected to it. This enables the test results for such configuration to be compatible with that required for hotspot mode when the body-worn accessory test separation distance is greater than or equal to that required for hotspot mode, when applicable. When the reported SAR for body-worn accessory, measured without a headset connected to the handset is  $> 1.2$  W/kg, the highest reported SAR configuration for that wireless mode and frequency band should be repeated for that body-worn accessory with a handset attached to the handset.

Accessories for body-worn operation configurations are divided into two categories: those that do not contain metallic components and those that do contain metallic components. When multiple accessories that do not contain metallic components are supplied with the device, the device is tested with only the accessory that dictates the closest spacing to the body. Then multiple accessories that contain metallic components are test with the device with each accessory. If multiple accessories share an identical metallic component (i.e. the same metallic belt-chip used with different holsters with no other metallic components) only the accessory that dictates the closest spacing to the body is tested.

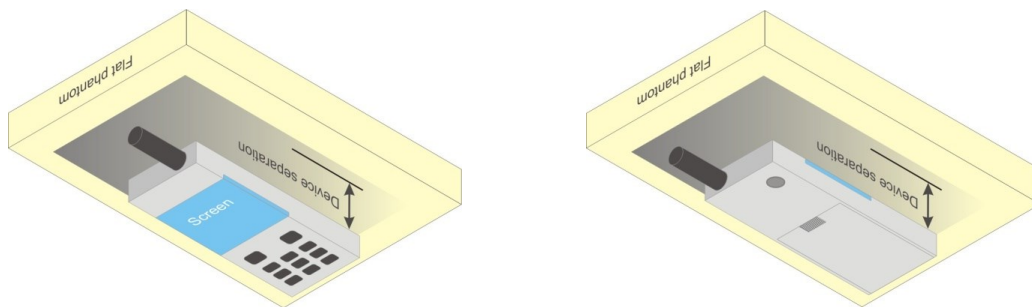

Fig 12.4 Body Worn Position



## **12.5 Product Specific 10g SAR Exposure**

For smart phones with a display diagonal dimension > 15.0 cm or an overall diagonal dimension > 16.0 cm that provide similar mobile web access and multimedia support found in mini-tablets or UMPC mini-tablets that support voice calls next to the ear, According to KDB648474 D04v01r03, the following phablet procedures should be applied to evaluate SAR compliance for each applicable wireless modes and frequency band. Devices marketed as phablets, regardless of form factors and operating characteristics must be tested as a phablet to determine SAR compliance

1. The normally required head and body-worn accessory SAR test procedures for handsets, including hotspot mode, must be applied.
2. The UMPC mini-tablet procedures must also be applied to test the SAR of all surfaces and edges with an antenna located at  $\leq 25$  mm from that surface or edge, in direct contact with a flat phantom, for 10-g extremity SAR according to the body-equivalent tissue dielectric parameters in KDB 865664 to address interactive hand use exposure conditions.6 The UMPC mini-tablet 1-g SAR at 5 mm is not required. When hotspot mode applies, 10-g extremity SAR is required only for the surfaces and edges with hotspot mode 1-g reported SAR > 1.2 W/kg.

## **12.6 Wireless Router**

Some battery-operated handsets have the capability to transmit and receive user through simultaneous transmission of WIFI simultaneously with a separate licensed transmitter. The FCC has provided guidance in FCC KDB Publication 941225 D06 v02r01 where SAR test considerations for handsets ( $L \times W \geq 9$  cm x 5 cm) are based on a composite test separation distance of 10mm from the front, back and edges of the device containing transmitting antennas within 2.5cm of their edges, determined from general mixed use conditions for this type of devices. Since the hotspot SAR results may overlap with the body-worn accessory SAR requirements, the more conservative configurations can be considered, thus excluding some body-worn accessory SAR tests.

When the user enables the personal wireless router functions for the handset, actual operations include simultaneous transmission of both the WIFI transmitter and another licensed transmitter. Both transmitters often do not transmit at the same transmitting frequency and thus cannot be evaluated for SAR under actual use conditions due to the limitations of the SAR assessment probes. Therefore, SAR must be evaluated for each frequency transmission and mode separately and spatially summed with the WIFI transmitter according to FCC KDB Publication 447498 D01v06 publication procedures. The "Portable Hotspot" feature on the handset was NOT activated during SAR assessments, to ensure the SAR measurements were evaluated for a single transmission frequency RF signal at a time.



### 13. Conducted RF Output Power (Unit: dBm)

#### <GSM Conducted Power>

**General Note:**

1. Per KDB 447498 D01v06, the maximum output power channel is used for SAR testing and for further SAR test reduction.
2. Per KDB 941225 D01v03r01, for SAR test reduction for GSM / GPRS / EDGE modes is determined by the source-based time-averaged output power including tune-up tolerance. The mode with highest specified time-averaged output power should be tested for SAR compliance in the applicable exposure conditions. For modes with the same specified maximum output power and tolerance, the higher number time-slot configuration should be tested. Therefore, the GPRS (3Tx slots) for GSM850/GSM1900 is considered as the primary mode.
3. Other configurations of GSM / GPRS / EDGE are considered as secondary modes. The 3G SAR test reduction procedure is applied, when the maximum output power and tune-up tolerance specified for production units in a secondary mode is  $\leq \frac{1}{4}$  dB higher than the primary mode, SAR measurement is not required for the secondary mode
4. Power reduction which is triggered by hotspot/P-Sensor is implemented in GSM850 band. For hotspot/P-Sensor mode SAR testing, GPRS 3Tx slots were set in reduced power due to its highest frame-average power.
5. Power reduction which is triggered by hotspot/P-Sensor/handheld mode is implemented in GSM1900 band. For hotspot/P-sensor mode SAR testing, GPRS 4Tx slots was set in reduced power due to its highest frame-average power, and for handheld mode SAR testing, GPRS 3Tx slots was set in reduced power due to its highest frame-average power.

#### <Full Power Mode>

GSM850 Tx Channel	Burst Average Power (dBm)			Tune-up Limit (dBm)	Frame-Average Power (dBm)			Tune-up Limit (dBm)	
	128	189	251		128	189	251		
Frequency (MHz)	824.2	836.4	848.8		824.2	836.4	848.8		
GSM 1 Tx slot	33.20	33.17	33.49	33.50	24.20	24.17	24.49	24.50	
GPRS 1 Tx slot	33.18	33.15	33.48	33.50	24.18	24.15	24.48	24.50	
GPRS 2 Tx slots	31.92	31.96	32.33	32.50	25.92	25.96	26.33	26.50	
GPRS 3 Tx slots	29.83	29.92	30.31	31.00	25.57	25.66	26.05	26.74	
GPRS 4 Tx slots	27.86	28.24	28.30	29.50	24.86	25.24	25.30	26.50	
EDGE 1 Tx slot	26.90	26.98	27.08	28.00	17.90	17.98	18.08	19.00	
EDGE 2 Tx slots	25.46	25.57	25.68	26.50	19.46	19.57	19.68	20.50	
EDGE 3 Tx slots	23.67	23.74	23.84	25.00	19.41	19.48	19.58	20.74	
EDGE 4 Tx slots	21.81	21.88	22.02	23.50	18.81	18.88	19.02	20.50	
GSM1900		Burst Average Power (dBm)			Tune-up Limit (dBm)	Frame-Average Power (dBm)			Tune-up Limit (dBm)
Tx Channel		512	661	810		512	661	810	
Frequency (MHz)		1850.2	1880	1909.8		1850.2	1880	1909.8	
GSM 1 Tx slot		29.83	29.95	29.99	30.50	20.83	20.95	20.99	21.50
GPRS 1 Tx slot		29.81	29.93	29.99	30.50	20.81	20.93	20.99	21.50
GPRS 2 Tx slots		28.48	28.66	28.72	29.50	22.48	22.66	22.72	23.50
GPRS 3 Tx slots		26.67	26.82	26.87	28.00	22.41	22.56	22.61	23.74
GPRS 4 Tx slots		24.78	24.91	25.05	26.50	21.78	21.91	22.05	23.50
EDGE 1 Tx slot		25.68	25.79	25.89	27.00	16.68	16.79	16.89	18.00
EDGE 2 Tx slots		24.22	24.36	24.47	25.50	18.22	18.36	18.47	19.50
EDGE 3 Tx slots		22.38	22.51	22.61	24.00	18.12	18.25	18.35	19.74
EDGE 4 Tx slots		20.50	20.65	20.81	22.50	17.50	17.65	17.81	19.50

**Remark:** The frame-averaged power is linearly scaled the maximum burst averaged power over 8 time slots.

The calculated method are shown as below:

- Frame-averaged power = Maximum burst averaged power (1 Tx Slot) - 9 dB
- Frame-averaged power = Maximum burst averaged power (2 Tx Slots) - 6 dB
- Frame-averaged power = Maximum burst averaged power (3 Tx Slots) - 4.26 dB
- Frame-averaged power = Maximum burst averaged power (4 Tx Slots) - 3 dB

**<Reduced Power Mode for Hotspot On/P-Sensor On>**

GSM850 Tx Channel	Burst Average Power (dBm)			Tune-up Limit (dBm)	Frame-Average Power (dBm)			Tune-up Limit (dBm)
	128	189	251		128	189	251	
Frequency (MHz)	824.2	836.4	848.8		824.2	836.4	848.8	
GSM 1 Tx slot	30.89	31.32	31.30	32.00	21.89	22.32	22.30	23.00
GPRS 1 Tx slot	30.87	31.30	31.28	32.00	21.87	22.30	22.28	23.00
GPRS 2 Tx slots	29.70	29.76	30.13	31.00	23.70	23.76	24.13	25.00
GPRS 3 Tx slots	27.95	28.23	28.30	29.50	23.69	23.97	24.04	25.24
GPRS 4 Tx slots	26.12	26.22	26.47	28.00	23.12	23.22	23.47	25.00
EDGE 1 Tx slot	26.05	26.05	26.16	28.00	17.05	17.05	17.16	19.00
EDGE 2 Tx slots	25.27	25.32	25.44	26.50	19.27	19.32	19.44	20.50
EDGE 3 Tx slots	23.50	23.52	23.59	25.00	19.24	19.26	19.33	20.74
EDGE 4 Tx slots	21.58	21.70	21.78	23.50	18.58	18.70	18.78	20.50
<b>GSM1900</b>								
Tx Channel	Burst Average Power (dBm)			Tune-up Limit (dBm)	Frame-Average Power (dBm)			Tune-up Limit (dBm)
	512	661	810		512	661	810	
Frequency (MHz)	1850.2	1880	1909.8		1850.2	1880	1909.8	
GSM 1 Tx slot	22.49	22.60	22.79	23.00	13.49	13.60	13.79	14.00
GPRS 1 Tx slot	22.48	22.59	22.77	23.00	13.48	13.59	13.77	14.00
GPRS 2 Tx slots	21.28	21.37	21.53	22.00	15.28	15.37	15.53	16.00
GPRS 3 Tx slots	19.11	19.19	19.38	20.00	14.85	14.93	15.12	15.74
GPRS 4 Tx slots	18.65	18.65	18.93	19.00	15.65	15.65	15.93	16.00
EDGE 1 Tx slot	20.23	20.37	20.42	21.00	11.23	11.37	11.42	12.00
EDGE 2 Tx slots	18.64	18.81	18.90	20.00	12.64	12.81	12.90	14.00
EDGE 3 Tx slots	16.36	16.41	16.51	18.00	12.10	12.15	12.25	13.74
EDGE 4 Tx slots	15.01	15.16	15.33	17.00	12.01	12.16	12.33	14.00

**Remark:** The frame-averaged power is linearly scaled the maximum burst averaged power over 8 time slots.

The calculated method are shown as below:

Frame-averaged power = Maximum burst averaged power (1 Tx Slot) - 9 dB

Frame-averaged power = Maximum burst averaged power (2 Tx Slots) - 6 dB

Frame-averaged power = Maximum burst averaged power (3 Tx Slots) - 4.26 dB

Frame-averaged power = Maximum burst averaged power (4 Tx Slots) - 3 dB

**<Reduced Power Mode for Handheld On>**

GSM1900 Tx Channel	Burst Average Power (dBm)			Tune-up Limit (dBm)	Frame-Average Power (dBm)			Tune-up Limit (dBm)
	512	661	810		512	661	810	
Frequency (MHz)	1850.2	1880	1909.8		1850.2	1880	1909.8	
GSM 1 Tx slot	27.76	27.92	27.99	29.00	18.76	18.92	18.99	20.00
GPRS 1 Tx slot	27.75	27.91	27.98	29.00	18.75	18.91	18.98	20.00
GPRS 2 Tx slots	26.48	26.62	26.66	28.00	20.48	20.62	20.66	22.00
GPRS 3 Tx slots	24.62	24.71	24.79	26.50	20.36	20.45	20.53	22.24
GPRS 4 Tx slots	23.02	23.12	23.07	25.00	20.02	20.12	20.07	22.00
EDGE 1 Tx slot	25.15	25.27	25.35	27.00	16.15	16.27	16.35	18.00
EDGE 2 Tx slots	23.93	24.02	24.09	25.50	17.93	18.02	18.09	19.50
EDGE 3 Tx slots	22.15	22.21	22.27	24.00	17.89	17.95	18.01	19.74
EDGE 4 Tx slots	20.57	20.53	20.64	22.50	17.57	17.33	17.64	19.50

**Remark:** The frame-averaged power is linearly scaled the maximum burst averaged power over 8 time slots.

The calculated method are shown as below:

Frame-averaged power = Maximum burst averaged power (1 Tx Slot) - 9 dB

Frame-averaged power = Maximum burst averaged power (2 Tx Slots) - 6 dB

Frame-averaged power = Maximum burst averaged power (3 Tx Slots) - 4.26 dB

Frame-averaged power = Maximum burst averaged power (4 Tx Slots) - 3 dB



**<WCDMA Conducted Power>**

1. The following tests were conducted according to the test requirements outlines in 3GPP TS 34.121 specification.
2. The procedures in KDB 941225 D01v03r01 are applied for 3GPP Rel. 6 HSPA to configure the device in the required sub-test mode(s) to determine SAR test exclusion.
3. For DC-HSDPA, the device was configured according to the H-Set 12, Fixed Reference Channel (FRC) configuration in Table C.8.1.12 of 3GPP TS 34.121-1, with the primary and the secondary serving HS-DSCH Cell enabled during the power measurement.

A summary of these settings are illustrated below:

**HSDPA Setup Configuration:**

- a. The EUT was connected to Base Station Agilent E5515C referred to the Setup Configuration.
- b. The RF path losses were compensated into the measurements.
- c. A call was established between EUT and Base Station with following setting:
  - i. Set Gain Factors ( $\beta_c$  and  $\beta_d$ ) and parameters were set according to each
  - ii. Specific sub-test in the following table, C10.1.4, quoted from the TS 34.121
  - iii. Set RMC 12.2Kbps + HSDPA mode.
  - iv. Set Cell Power = -86 dBm
  - v. Set HS-DSCH Configuration Type to FRC (H-set 1, QPSK)
  - vi. Select HSDPA Uplink Parameters
  - vii. Set Delta ACK, Delta NACK and Delta CQI = 8
  - viii. Set Ack-Nack Repetition Factor to 3
  - ix. Set CQI Feedback Cycle (k) to 4 ms
  - x. Set CQI Repetition Factor to 2
  - xi. Power Ctrl Mode = All Up bits
- d. The transmitted maximum output power was recorded.

**Table C.10.1.4:  $\beta$  values for transmitter characteristics tests with HS-DPCCH**

Sub-test	$\beta_c$	$\beta_d$	$\beta_d$ (SF)	$\beta_c/\beta_d$	$\beta_{HS}$ (Note 1, Note 2)	CM (dB) (Note 3)	MPR (dB) (Note 3)
1	2/15	15/15	64	2/15	4/15	0.0	0.0
2	12/15 (Note 4)	15/15 (Note 4)	64	12/15 (Note 4)	24/15	1.0	0.0
3	15/15	8/15	64	15/8	30/15	1.5	0.5
4	15/15	4/15	64	15/4	30/15	1.5	0.5

Note 1:  $\Delta_{ACK}, \Delta_{NACK}$  and  $\Delta_{CQI} = 30/15$  with  $\beta_{HS} = 30/15 * \beta_c$ .

Note 2: For the HS-DPCCH power mask requirement test in clause 5.2C, 5.7A, and the Error Vector Magnitude (EVM) with HS-DPCCH test in clause 5.13.1A, and HSDPA EVM with phase discontinuity in clause 5.13.1AA,  $\Delta_{ACK}$  and  $\Delta_{NACK} = 30/15$  with  $\beta_{HS} = 30/15 * \beta_c$ , and  $\Delta_{CQI} = 24/15$  with  $\beta_{HS} = 24/15 * \beta_c$ .

Note 3: CM = 1 for  $\beta_c/\beta_d = 12/15, \beta_{HS}/\beta_c = 24/15$ . For all other combinations of DPDCH, DPCCH and HS-DPCCH the MPR is based on the relative CM difference. This is applicable for only UEs that support HSDPA in release 6 and later releases.

Note 4: For subtest 2 the  $\beta_c/\beta_d$  ratio of 12/15 for the TFC during the measurement period (TF1, TF0) is achieved by setting the signalled gain factors for the reference TFC (TF1, TF1) to  $\beta_c = 11/15$  and  $\beta_d = 15/15$ .

**Setup Configuration**

**HSUPA Setup Configuration:**

- a. The EUT was connected to Base Station Agilent E5515C referred to the Setup Configuration.
- b. The RF path losses were compensated into the measurements.
- c. A call was established between EUT and Base Station with following setting \* :
  - i. Call Configs = 5.2B, 5.9B, 5.10B, and 5.13.2B with QPSK
  - ii. Set the Gain Factors ( $\beta_c$  and  $\beta_d$ ) and parameters (AG Index) were set according to each specific sub-test in the following table, C11.1.3, quoted from the TS 34.121
  - iii. Set Cell Power = -86 dBm
  - iv. Set Channel Type = 12.2k + HSPA
  - v. Set UE Target Power
  - vi. Power Ctrl Mode= Alternating bits
  - vii. Set and observe the E-TFCl
  - viii. Confirm that E-TFCl is equal to the target E-TFCl of 75 for sub-test 1, and other subtest's E-TFCl
- d. The transmitted maximum output power was recorded.

**Table C.11.1.3:  $\beta$  values for transmitter characteristics tests with HS-DPCCH and E-DCH**

Sub-test	$\beta_c$	$\beta_d$	$\beta_d$ (SF)	$\beta_c/\beta_d$	$\beta_{HS}$ (Note1)	$\beta_{ec}$	$\beta_{ed}$ (Note 4) (Note 5)	$\beta_{ed}$ (SF)	$\beta_{ed}$ (Codes)	CM (dB) (Note 2)	MPR (dB) (Note 2) (Note 6)	AG Index (Note 5)	E-TFCl
1	11/15 (Note 3)	15/15 (Note 3)	64	11/15 (Note 3)	22/15	209/25	1309/225	4	1	1.0	0.0	20	75
2	6/15	15/15	64	6/15	12/15	12/15	94/75	4	1	3.0	2.0	12	67
3	15/15	9/15	64	15/9	30/15	30/15	$\beta_{ed1}: 47/15$ $\beta_{ed2}: 47/15$	4	2	2.0	1.0	15	92
4	2/15	15/15	64	2/15	4/15	2/15	56/75	4	1	3.0	2.0	17	71
5	15/15	0	-	-	5/15	5/15	47/15	4	1	1.0	0.0	12	67

Note 1: For sub-test 1 to 4,  $\Delta_{ACK}$ ,  $\Delta_{NACK}$  and  $\Delta_{CQI} = 30/15$  with  $\beta_{hs} = 30/15 * \beta_c$ . For sub-test 5,  $\Delta_{ACK}$ ,  $\Delta_{NACK}$  and  $\Delta_{CQI} = 5/15$  with  $\beta_{hs} = 5/15 * \beta_c$ .

Note 2: CM = 1 for  $\beta_c/\beta_d = 12/15$ ,  $\beta_{hs}/\beta_c = 24/15$ . For all other combinations of DPDCH, DPCCH, HS-DPCCH, E-DPDCH and E-DPCCH the MPR is based on the relative CM difference.

Note 3: For subtest 1 the  $\beta_c/\beta_d$  ratio of 11/15 for the TFC during the measurement period (TF1, TF0) is achieved by setting the signalled gain factors for the reference TFC (TF1, TF1) to  $\beta_c = 10/15$  and  $\beta_d = 15/15$ .

Note 4: In case of testing by UE using E-DPDCH Physical Layer category 1, Sub-test 3 is omitted according to TS25.306 Table 5.1g.

Note 5:  $\beta_{ed}$  can not be set directly; it is set by Absolute Grant Value.

Note 6: For subtests 2, 3 and 4, UE may perform E-DPDCH power scaling at max power which could results in slightly smaller MPR values.

**Setup Configuration**

**DC-HSDPA 3GPP release 8 Setup Configuration:**

- a. The EUT was connected to Base Station Agilent E5515C referred to the Setup Configuration below
- b. The RF path losses were compensated into the measurements.
- c. A call was established between EUT and Base Station with following setting:
  - i. Set RMC 12.2Kbps + HSDPA mode.
  - ii. Set Cell Power = -25 dBm
  - iii. Set HS-DSCH Configuration Type to FRC (H-set 12, QPSK)
  - iv. Select HSDPA Uplink Parameters
  - v. Set Gain Factors ( $\beta_c$  and  $\beta_d$ ) and parameters were set according to each Specific sub-test in the following table, C10.1.4, quoted from the TS 34.121
    - a). Subtest 1:  $\beta_c/\beta_d=2/15$
    - b). Subtest 2:  $\beta_c/\beta_d=12/15$
    - c). Subtest 3:  $\beta_c/\beta_d=15/8$
    - d). Subtest 4:  $\beta_c/\beta_d=15/4$
  - vi. Set Delta ACK, Delta NACK and Delta CQI = 8
  - vii. Set Ack-Nack Repetition Factor to 3
  - viii. Set CQI Feedback Cycle (k) to 4 ms
  - ix. Set CQI Repetition Factor to 2
  - x. Power Ctrl Mode = All Up bits
- d. The transmitted maximum output power was recorded.

The following tests were conducted according to the test requirements outlines in 3GPP TS 34.121 specification. A summary of these settings are illustrated below:

**C.8.1.12 Fixed Reference Channel Definition H-Set 12**

**Table C.8.1.12: Fixed Reference Channel H-Set 12**

Parameter	Unit	Value
Nominal Avg. Inf. Bit Rate	kbps	60
Inter-TTI Distance	TTI's	1
Number of HARQ Processes	Processes	6
Information Bit Payload ( $N_{inf}$ )	Bits	120
Number Code Blocks	Blocks	1
Binary Channel Bits Per TTI	Bits	960
Total Available SML's in UE	SML's	19200
Number of SML's per HARQ Proc.	SML's	3200
Coding Rate		0.15
Number of Physical Channel Codes	Codes	1
Modulation		QPSK
Note 1: The RMC is intended to be used for DC-HSDPA mode and both cells shall transmit with identical parameters as listed in the table. Note 2: Maximum number of transmission is limited to 1, i.e., retransmission is not allowed. The redundancy and constellation version 0 shall be used.		

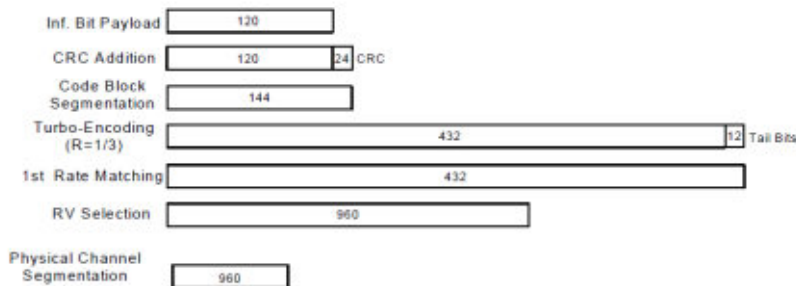

**Figure C.8.19: Coding rate for Fixed reference Channel H-Set 12 (QPSK)**

**Setup Configuration**



**<WCDMA Conducted Power>**

**General Note:**

1. Per KDB 941225 D01v03r01, for SAR testing is measured using a 12.2 kbps RMC with TPC bits configured to all "1's".
2. Per KDB 941225 D01v03r01, RMC 12.2kbps setting is used to evaluate SAR. The maximum output power and tune-up tolerance specified for production units in HSDPA / HSUPA / DC-HSDPA is  $\leq \frac{1}{4}$  dB higher than RMC 12.2Kbps or when the highest reported SAR of the RMC12.2Kbps is scaled by the ratio of specified maximum output power and tune-up tolerance of HSDPA / HSUPA / DC-HSDPA to RMC12.2Kbps and the adjusted SAR is  $\leq 1.2$  W/kg, SAR measurement is not required for HSDPA / HSUPA / DC-HSDPA, and according to the following RF output power, the output power results of the secondary modes (HSUPA, HSDPA, DC-HSDPA) are less than  $\frac{1}{4}$  dB higher than the primary modes; therefore, SAR measurement is not required for HSDPA / HSUPA / DC-HSDPA.

**<Full Power Mode>**

Band		WCDMA Band II			Tune-up Limit (dBm)	WCDMA Band V			Tune-up Limit (dBm)
Tx Channel		9262	9400	9538		4132	4182	4233	
Rx Channel		9662	9800	9938		4357	4407	4458	
Frequency (MHz)		1852.4	1880	1907.6		826.4	836.4	846.6	
3GPP Rel 99	AMR 12.2Kbps	23.14	23.16	23.51	24.00	23.19	23.29	23.13	24.00
3GPP Rel 99	RMC 12.2Kbps	23.15	23.17	23.52	24.00	23.20	23.30	23.14	24.00
3GPP Rel 6	HSDPA Subtest-1	22.05	22.05	22.32	23.00	21.99	21.94	22.03	23.00
3GPP Rel 6	HSDPA Subtest-2	22.10	22.05	22.35	23.00	22.00	21.77	22.10	23.00
3GPP Rel 6	HSDPA Subtest-3	21.57	21.51	21.80	22.50	21.48	21.79	21.58	22.50
3GPP Rel 6	HSDPA Subtest-4	21.59	21.50	21.83	22.50	21.47	21.20	21.63	22.50
3GPP Rel 8	DC-HSDPA Subtest-1	21.55	21.55	21.82	23.00	21.49	21.44	21.53	23.00
3GPP Rel 8	DC-HSDPA Subtest-2	21.60	21.55	21.85	23.00	21.48	21.25	21.58	23.00
3GPP Rel 8	DC-HSDPA Subtest-3	20.97	20.91	21.20	22.50	20.96	21.27	21.06	22.50
3GPP Rel 8	DC-HSDPA Subtest-4	20.98	20.89	21.22	22.50	20.96	20.69	21.12	22.50
3GPP Rel 6	HSUPA Subtest-1	21.89	22.02	22.17	23.00	21.92	21.92	21.91	23.00
3GPP Rel 6	HSUPA Subtest-2	19.99	20.05	20.27	21.00	19.93	19.95	19.96	21.00
3GPP Rel 6	HSUPA Subtest-3	21.02	21.09	21.24	22.00	20.94	20.93	20.92	22.00
3GPP Rel 6	HSUPA Subtest-4	20.02	20.06	20.28	21.00	19.97	20.03	19.94	21.00
3GPP Rel 6	HSUPA Subtest-5	22.10	22.10	22.30	23.00	21.80	21.90	21.79	23.00

**<Reduced Power Mode for Hotspot On/P-Sensor On>**

Band		WCDMA Band V			Tune-up Limit (dBm)
Tx Channel		4132	4182	4233	
Rx Channel		4357	4407	4458	
Frequency (MHz)		826.4	836.4	846.6	
3GPP Rel 99	AMR 12.2Kbps	20.68	20.75	20.72	21.80
3GPP Rel 99	RMC 12.2Kbps	20.69	20.76	20.74	21.80
3GPP Rel 6	HSDPA Subtest-1	19.47	19.49	19.51	20.00
3GPP Rel 6	HSDPA Subtest-2	19.47	19.50	19.52	20.00
3GPP Rel 6	HSDPA Subtest-3	18.96	19.02	18.99	19.50
3GPP Rel 6	HSDPA Subtest-4	18.95	18.97	19.00	19.50
3GPP Rel 8	DC-HSDPA Subtest-1	18.95	18.99	19.01	20.00
3GPP Rel 8	DC-HSDPA Subtest-2	18.97	19.00	19.02	20.00
3GPP Rel 8	DC-HSDPA Subtest-3	18.45	18.51	18.48	19.50
3GPP Rel 8	DC-HSDPA Subtest-4	18.43	18.45	18.48	19.50
3GPP Rel 6	HSUPA Subtest-1	19.39	19.49	19.48	20.00
3GPP Rel 6	HSUPA Subtest-2	17.41	17.46	17.44	18.00
3GPP Rel 6	HSUPA Subtest-3	18.44	18.49	18.43	19.00
3GPP Rel 6	HSUPA Subtest-4	17.40	17.33	17.50	18.00
3GPP Rel 6	HSUPA Subtest-5	19.40	19.50	19.40	20.00



**<Reduced Power Mode for Hotspot On >**

Band		WCDMA Band II			Tune-up Limit (dBm)
Tx Channel		9262	9400	9538	
Rx Channel		9662	9800	9938	
Frequency (MHz)		1852.4	1880	1907.6	
3GPP Rel 99	AMR 12.2Kbps	12.38	12.38	12.67	13.80
3GPP Rel 99	RMC 12.2Kbps	12.40	12.39	12.68	13.80
3GPP Rel 6	HSDPA Subtest-1	11.45	11.55	11.70	12.00
3GPP Rel 6	HSDPA Subtest-2	11.49	11.59	11.73	12.00
3GPP Rel 6	HSDPA Subtest-3	10.98	11.04	11.22	11.50
3GPP Rel 6	HSDPA Subtest-4	10.97	11.09	11.25	11.50
3GPP Rel 8	DC-HSDPA Subtest-1	10.93	11.03	11.18	12.00
3GPP Rel 8	DC-HSDPA Subtest-2	10.98	11.08	11.22	12.00
3GPP Rel 8	DC-HSDPA Subtest-3	10.44	10.50	10.68	11.50
3GPP Rel 8	DC-HSDPA Subtest-4	10.42	10.54	10.70	11.50
3GPP Rel 6	HSUPA Subtest-1	11.14	11.13	11.42	12.00
3GPP Rel 6	HSUPA Subtest-2	9.24	9.23	9.52	10.00
3GPP Rel 6	HSUPA Subtest-3	10.27	10.26	10.55	11.00
3GPP Rel 6	HSUPA Subtest-4	9.27	9.26	9.55	10.00
3GPP Rel 6	HSUPA Subtest-5	11.35	11.34	11.63	12.00

**<Reduced Power Mode for P-Sensor On>**

Band		WCDMA Band II			Tune-up Limit (dBm)
Tx Channel		9262	9400	9538	
Rx Channel		9662	9800	9938	
Frequency (MHz)		1852.4	1880	1907.6	
3GPP Rel 99	AMR 12.2Kbps	15.29	15.33	15.36	16.50
3GPP Rel 99	RMC 12.2Kbps	15.30	15.33	15.38	16.50
3GPP Rel 6	HSDPA Subtest-1	14.32	14.37	14.49	15.50
3GPP Rel 6	HSDPA Subtest-2	14.29	14.39	14.45	15.50
3GPP Rel 6	HSDPA Subtest-3	13.79	13.89	13.99	15.00
3GPP Rel 6	HSDPA Subtest-4	13.75	13.75	13.95	15.00
3GPP Rel 8	DC-HSDPA Subtest-1	13.78	13.86	13.99	15.50
3GPP Rel 8	DC-HSDPA Subtest-2	13.75	13.86	14.02	15.50
3GPP Rel 8	DC-HSDPA Subtest-3	13.20	13.39	13.47	15.00
3GPP Rel 8	DC-HSDPA Subtest-4	13.19	13.34	13.50	15.00
3GPP Rel 6	HSUPA Subtest-1	14.28	14.33	14.47	15.50
3GPP Rel 6	HSUPA Subtest-2	12.34	12.39	12.49	13.50
3GPP Rel 6	HSUPA Subtest-3	13.32	13.34	13.36	14.50
3GPP Rel 6	HSUPA Subtest-4	12.28	12.32	12.37	13.50
3GPP Rel 6	HSUPA Subtest-5	14.26	14.40	14.30	15.50

**<Reduced Power Mode for Handheld On>**

Band		WCDMA Band II			Tune-up Limit (dBm)
Tx Channel		9262	9400	9538	
Rx Channel		9662	9800	9938	
Frequency (MHz)		1852.4	1880	1907.6	
3GPP Rel 99	AMR 12.2Kbps	18.95	19.00	19.30	20.30
3GPP Rel 99	RMC 12.2Kbps	18.96	19.02	19.31	20.30
3GPP Rel 6	HSDPA Subtest-1	18.29	18.37	18.50	19.00
3GPP Rel 6	HSDPA Subtest-2	18.28	18.36	18.50	19.00
3GPP Rel 6	HSDPA Subtest-3	17.72	17.89	17.99	18.50
3GPP Rel 6	HSDPA Subtest-4	17.76	17.87	18.03	18.50
3GPP Rel 8	DC-HSDPA Subtest-1	17.78	17.86	17.99	19.00
3GPP Rel 8	DC-HSDPA Subtest-2	17.78	17.86	18.00	19.00
3GPP Rel 8	DC-HSDPA Subtest-3	17.20	17.37	17.47	18.50
3GPP Rel 8	DC-HSDPA Subtest-4	17.23	17.34	17.50	18.50
3GPP Rel 6	HSUPA Subtest-1	18.19	18.33	18.47	19.00
3GPP Rel 6	HSUPA Subtest-2	16.21	16.35	16.49	17.00
3GPP Rel 6	HSUPA Subtest-3	17.32	17.34	17.36	18.00
3GPP Rel 6	HSUPA Subtest-4	16.27	16.32	16.37	17.00
3GPP Rel 6	HSUPA Subtest-5	18.30	18.30	18.30	19.00



**<CDMA2000 Conducted Power>**

**General Note:**

1. Per KDB 941225 D01v03r01, SAR for head exposure is measured in RC3 with the handset configured to transmit at full rate in SO55.
2. Per KDB 941225 D01v03r01, in Hotspot mode EUT is treated as data device and SAR is tested with Ev-Do Rev 0 (RTAP 153.6kbps) as the primary mode.
3. Per KDB 941225 D01v03r01, for Body-worn accessory SAR is measured in RC3 with the handset configured in TDSO/SO32 to transmit at full rate on FCH only with all other code channels disabled. The body-worn accessory procedures in KDB Publication 447498 are applied. The 3G SAR test reduction procedure is applied to the multiple code channel configuration (FCH+SCH), with FCH only as the primary mode.

**<Full Power Mode>**

Band	CDMA2000 BC0			Tune-up Limit (dBm)	CDMA2000 BC1			Tune-up Limit (dBm)
	Tx Channel	1013	384		777	25	600	
Frequency (MHz)	824.7	836.52	848.31		1851.25	1880	1908.75	
RC1 SO55	23.94	24.09	24.14	25.00	23.79	23.83	23.99	25.00
RC3 SO55	23.93	24.11	24.15	25.00	23.70	23.75	23.91	25.00
RC3 SO32 (F+SCH)	23.92	24.08	24.14	25.00	23.70	23.74	23.81	25.00
RC3 SO32 (+SCH)	23.82	23.97	24.06	25.00	23.68	23.74	23.90	25.00
RTAP 153.6Kbps	23.95	24.04	24.11	25.00	23.77	23.86	23.97	25.00
RETAP 4096Bits	23.84	24.02	24.10	25.00	23.76	23.87	23.96	25.00

**<Reduced Power Mode for Hotspot On/P-Sensor On>**

Band	CDMA2000 BC0			Tune-up Limit (dBm)
	Tx Channel	1013	384	
Frequency (MHz)	824.7	836.52	848.31	
RC1 SO55	19.56	19.74	19.91	21.00
RC3 SO55	19.57	19.72	19.90	21.00
RC3 SO32 (F+SCH)	19.60	19.75	19.92	21.00
RC3 SO32 (+SCH)	19.58	19.70	19.90	21.00
RTAP 153.6Kbps	19.54	19.73	19.89	21.00
RETAP 4096Bits	19.57	19.72	19.91	21.00



**<Reduced Power Mode for Hotspot On >**

Band	CDMA2000 BC1			Tune-up Limit (dBm)
	25	600	1175	
Tx Channel	1851.25	1880	1908.75	
Frequency (MHz)	1851.25	1880	1908.75	
RC1 SO55	12.72	12.80	12.90	14.00
RC3 SO55	12.67	12.83	12.99	14.00
RC3 SO32 (F+SCH)	12.65	12.77	12.95	14.00
RC3 SO32 (+SCH)	12.70	12.72	12.91	14.00
RTAP 153.6Kbps	12.66	12.75	12.88	14.00
RETAP 4096Bits	12.65	12.72	12.85	14.00

**<Reduced Power Mode for P-Sensor On >**

Band	CDMA2000 BC1			Tune-up Limit (dBm)
	25	600	1175	
Tx Channel	1851.25	1880	1908.75	
Frequency (MHz)	1851.25	1880	1908.75	
RC1 SO55	15.20	15.30	15.48	16.50
RC3 SO55	15.28	15.35	15.58	16.50
RC3 SO32 (F+SCH)	15.33	15.28	15.50	16.50
RC3 SO32 (+SCH)	15.24	15.20	15.48	16.50
RTAP 153.6Kbps	15.19	15.22	15.49	16.50
RETAP 4096Bits	15.18	15.20	15.45	16.50

**<Reduced Power Mode for Handheld On >**

Band	CDMA2000 BC1			Tune-up Limit (dBm)
	25	600	1175	
Tx Channel	1851.25	1880	1908.75	
Frequency (MHz)	1851.25	1880	1908.75	
RC1 SO55	18.05	18.14	18.36	19.50
RC3 SO55	18.10	18.17	18.37	19.50
RC3 SO32 (F+SCH)	18.02	18.15	18.32	19.50
RC3 SO32 (+SCH)	18.01	18.12	18.34	19.50
RTAP 153.6Kbps	18.07	18.16	18.36	19.50
RETAP 4096Bits	18.03	18.11	18.33	19.50

**<LTE Conducted Power>**

**General Note:**

1. Anritsu MT8820C base station simulator was used to setup the connection with EUT; the frequency band, channel bandwidth, RB allocation configuration, modulation type are set in the base station simulator to configure EUT transmitting at maximum power and at different configurations which are requested to be reported to FCC, for conducted power measurement and SAR testing.
2. Per KDB 941225 D05v02r05, when a properly configured base station simulator is used for the SAR and power measurements, spectrum plots for each RB allocation and offset configuration is not required.
3. Per KDB 941225 D05v02r05, start with the largest channel bandwidth and measure SAR for QPSK with 1 RB allocation, using the RB offset and required test channel combination with the highest maximum output power for RB offsets at the upper edge, middle and lower edge of each required test channel.
4. Per KDB 941225 D05v02r05, 50% RB allocation for QPSK SAR testing follows 1RB QPSK allocation procedure.
5. Per KDB 941225 D05v02r05, For QPSK with 100% RB allocation, SAR is not required when the highest maximum output power for 100 % RB allocation is less than the highest maximum output power in 50% and 1 RB allocations and the highest reported SAR for 1 RB and 50% RB allocation are  $\leq 0.8$  W/kg. Otherwise, SAR is measured for the highest output power channel; and if the reported SAR is  $> 1.45$  W/kg, the remaining required test channels must also be tested.
6. Per KDB 941225 D05v02r05, 16QAM/64QAM output power for each RB allocation configuration is  $>$  not  $\frac{1}{2}$  dB higher than the same configuration in QPSK and the reported SAR for the QPSK configuration is  $\leq 1.45$  W/kg; Per KDB 941225 D05v02r05, 16QAM/64QA SAR testing is not required.
7. Per KDB 941225 D05v02r05, Smaller bandwidth output power for each RB allocation configuration is  $>$  not  $\frac{1}{2}$  dB higher than the same configuration in the largest supported bandwidth, and the reported SAR for the largest supported bandwidth is  $\leq 1.45$  W/kg; Per KDB 941225 D05v02r05, smaller bandwidth SAR testing is not required.
8. For LTE B4 / B5 the maximum bandwidth does not support three non-overlapping channels, per KDB 941225 D05v02r05, when a device supports overlapping channel assignment in a channel bandwidth configuration, the middle channel of the group of overlapping channels should be selected for testing.
9. LTE B4 SAR test was covered by B66; according to April 2015 TCB workshop, SAR test for overlapping LTE bands can be reduced if
  - a. the maximum output power, including tolerance, for the smaller band is  $\leq$  the larger band to qualify for the SAR test exclusion
  - b. the channel bandwidth and other operating parameters for the smaller band are fully supported by the larger band
10. According to 2017 TCB workshop, for 64 QAM and 16 QAM should be verified by checking the signal constellation with a call box to avoid incorrect maximum power levels due to MPR and other requirements associated with signal modulation, and the following figure is taken from the "Fundamental Measurement >> Modulation Analysis >> constellation" mode of the device connect to the MT8821C base station, therefore, the device 64QAM and 16QAM signal modulation are correct.

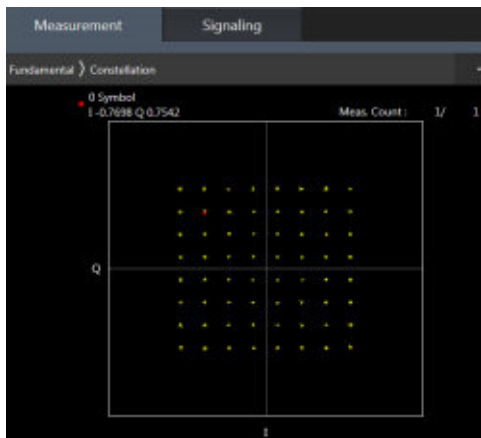

**64QAM**



**16QAM**



<Full Power Mode>

<LTE Band 2>

BW [MHz]	Modulation	RB Size	RB Offset	Power Low Ch. / Freq.	Power Middle Ch. / Freq.	Power High Ch. / Freq.	Tune-up limit (dBm)	MPR (dB)
Channel				18700	18900	19100		
Frequency (MHz)				1860	1880	1900		
20	QPSK	1	0	23.17	23.28	23.33	24	0
20	QPSK	1	49	22.79	22.89	23.19		
20	QPSK	1	99	23.00	22.94	23.16		
20	QPSK	50	0	21.98	22.14	22.38	23	1
20	QPSK	50	24	21.80	22.01	22.29		
20	QPSK	50	50	21.79	22.02	22.33		
20	QPSK	100	0	21.96	22.00	22.34	23	1
20	16QAM	1	0	22.27	22.74	22.81		
20	16QAM	1	49	21.95	22.39	22.69		
20	16QAM	1	99	22.35	22.51	22.78	22	2
20	16QAM	50	0	20.93	21.11	21.34		
20	16QAM	50	24	20.85	20.99	21.35		
20	16QAM	50	50	20.75	20.98	21.36	22	2
20	16QAM	100	0	20.81	20.97	21.33		
20	64QAM	1	0	21.20	21.68	21.11		
20	64QAM	1	49	21.16	21.22	21.13	22	2
20	64QAM	1	99	21.19	21.29	21.02		
20	64QAM	50	0	19.90	20.08	20.45		
20	64QAM	50	24	19.93	20.05	20.41	21	3
20	64QAM	50	50	19.82	19.93	20.43		
20	64QAM	100	0	19.87	20.02	20.41		
Channel				18675	18900	19125		
Frequency (MHz)				1857.5	1880	1902.5		
15	QPSK	1	0	22.91	23.03	23.31	24	0
15	QPSK	1	37	22.74	22.85	23.16		
15	QPSK	1	74	22.71	22.91	23.18		
15	QPSK	36	0	21.90	22.03	22.34	23	1
15	QPSK	36	20	21.89	22.02	22.33		
15	QPSK	36	39	21.81	21.99	22.28		
15	QPSK	75	0	21.87	22.01	22.34	23	1
15	16QAM	1	0	22.19	22.29	22.55		
15	16QAM	1	37	21.98	22.15	22.44		
15	16QAM	1	74	21.93	22.17	22.44	22	2
15	16QAM	36	0	20.94	21.08	21.33		
15	16QAM	36	20	20.87	21.02	21.33		
15	16QAM	36	39	20.80	20.97	21.26	22	2
15	16QAM	75	0	20.86	21.01	21.33		
15	64QAM	1	0	21.24	21.30	21.61		
15	64QAM	1	37	20.97	21.20	21.43	22	2
15	64QAM	1	74	20.93	21.14	21.44		
15	64QAM	36	0	19.93	20.07	20.40		
15	64QAM	36	20	19.90	20.06	20.34	21	3
15	64QAM	36	39	19.84	20.02	20.32		
15	64QAM	75	0	19.89	20.02	20.32		



Channel				18650	18900	19150	Tune-up limit (dBm)	MPR (dB)
Frequency (MHz)				1855	1880	1905		
10	QPSK	1	0	23.09	23.18	23.29	24	0
10	QPSK	1	25	22.74	22.89	23.19		
10	QPSK	1	49	22.90	23.08	23.21		
10	QPSK	25	0	21.87	22.02	22.32	23	1
10	QPSK	25	12	21.83	21.96	22.30		
10	QPSK	25	25	21.83	21.98	22.29		
10	QPSK	50	0	21.85	21.99	22.31		
10	16QAM	1	0	22.26	22.40	22.49	23	1
10	16QAM	1	25	21.98	22.16	22.43		
10	16QAM	1	49	22.07	22.31	22.42		
10	16QAM	25	0	20.93	21.04	21.32	22	2
10	16QAM	25	12	20.85	21.05	21.32		
10	16QAM	25	25	20.83	20.98	21.28		
10	16QAM	50	0	20.89	21.01	21.30		
10	64QAM	1	0	21.34	21.35	21.46	22	2
10	64QAM	1	25	21.02	21.07	21.42		
10	64QAM	1	49	21.18	21.26	21.41		
10	64QAM	25	0	19.90	20.02	20.36	21	3
10	64QAM	25	12	19.88	19.99	20.33		
10	64QAM	25	25	19.84	20.00	20.29		
10	64QAM	50	0	19.87	20.02	20.31		
Channel				18625	18900	19175	Tune-up limit (dBm)	MPR (dB)
Frequency (MHz)				1852.5	1880	1907.5		
5	QPSK	1	0	22.83	22.95	23.24	24	0
5	QPSK	1	12	22.73	22.85	23.23		
5	QPSK	1	24	22.75	22.91	23.20		
5	QPSK	12	0	21.85	21.95	22.28	23	1
5	QPSK	12	7	21.85	21.97	22.31		
5	QPSK	12	13	21.80	21.96	22.28		
5	QPSK	25	0	21.77	21.94	22.29		
5	16QAM	1	0	22.06	22.24	22.50	23	1
5	16QAM	1	12	22.00	22.18	22.46		
5	16QAM	1	24	22.03	22.22	22.43		
5	16QAM	12	0	20.86	21.02	21.29	22	2
5	16QAM	12	7	20.85	21.02	21.33		
5	16QAM	12	13	20.80	20.96	21.29		
5	16QAM	25	0	20.83	20.95	21.29		
5	64QAM	1	0	20.98	21.17	21.49	22	2
5	64QAM	1	12	20.89	21.06	21.40		
5	64QAM	1	24	20.91	21.10	21.36		
5	64QAM	12	0	19.90	20.06	20.33	21	3
5	64QAM	12	7	19.86	20.01	20.36		
5	64QAM	12	13	19.86	20.00	20.31		
5	64QAM	25	0	19.83	19.99	20.29		



Channel				18615	18900	19185	Tune-up limit (dBm)	MPR (dB)
Frequency (MHz)				1851.5	1880	1908.5		
3	QPSK	1	0	22.73	22.85	23.22	24	0
3	QPSK	1	8	22.91	22.94	22.93		
3	QPSK	1	14	22.84	22.83	22.76		
3	QPSK	8	0	22.70	22.45	22.56	23	1
3	QPSK	8	4	22.73	22.30	22.26		
3	QPSK	8	7	21.77	21.82	22.23		
3	QPSK	15	0	21.79	21.75	22.23		
3	16QAM	1	0	22.01	21.95	22.35	23	1
3	16QAM	1	8	22.07	21.98	22.44		
3	16QAM	1	14	21.97	22.05	22.25		
3	16QAM	8	0	20.84	20.85	21.34	22	2
3	16QAM	8	4	20.85	20.86	21.32		
3	16QAM	8	7	20.82	20.71	21.31		
3	16QAM	15	0	20.85	20.95	21.29		
3	64QAM	1	0	21.38	21.34	21.81	22	2
3	64QAM	1	8	21.40	21.34	21.96		
3	64QAM	1	14	21.30	21.57	21.82		
3	64QAM	8	0	20.42	20.34	20.67	21	3
3	64QAM	8	4	20.40	20.40	20.70		
3	64QAM	8	7	20.39	20.34	20.68		
3	64QAM	15	0	20.45	20.80	20.40		
Channel				18607	18900	19193	Tune-up limit (dBm)	MPR (dB)
Frequency (MHz)				1850.7	1880	1909.3		
1.4	QPSK	1	0	22.70	22.81	23.07	24	0
1.4	QPSK	1	3	22.70	22.82	23.13		
1.4	QPSK	1	5	22.76	22.76	23.04		
1.4	QPSK	3	0	22.72	22.84	23.15		
1.4	QPSK	3	1	22.71	22.89	23.25		
1.4	QPSK	3	3	22.71	22.90	23.19		
1.4	QPSK	6	0	21.72	21.86	22.14	23	1
1.4	16QAM	1	0	21.91	21.95	22.32	23	1
1.4	16QAM	1	3	21.95	22.10	22.41		
1.4	16QAM	1	5	21.87	21.98	22.29		
1.4	16QAM	3	0	21.71	21.92	22.17		
1.4	16QAM	3	1	21.76	21.92	22.23		
1.4	16QAM	3	3	21.77	21.95	22.19		
1.4	16QAM	6	0	20.76	20.93	21.23	22	2
1.4	64QAM	1	0	21.80	21.42	21.75	22	2
1.4	64QAM	1	3	21.30	21.49	21.78		
1.4	64QAM	1	5	21.45	21.37	21.71		
1.4	64QAM	3	0	21.45	21.38	21.66		
1.4	64QAM	3	1	21.80	21.41	21.78		
1.4	64QAM	3	3	21.44	21.39	21.74		
1.4	64QAM	6	0	20.36	20.32	20.58	21	3



<LTE Band 4>

BW [MHz]	Modulation	RB Size	RB Offset	Power Low Ch. / Freq.	Power Middle Ch. / Freq.	Power High Ch. / Freq.	Tune-up limit (dBm)	MPR (dB)
Channel				20050	20175	20300		
Frequency (MHz)				1720	1732.5	1745		
20	QPSK	1	0	23.17	23.23	23.21	24	0
20	QPSK	1	49	22.90	22.92	23.02		
20	QPSK	1	99	22.98	22.93	23.05		
20	QPSK	50	0	21.96	22.12	22.22	23	1
20	QPSK	50	24	21.95	22.05	22.08		
20	QPSK	50	50	22.03	21.95	22.17		
20	QPSK	100	0	21.98	22.07	22.10	23	1
20	16QAM	1	0	22.36	22.46	22.45		
20	16QAM	1	49	22.13	22.17	22.29		
20	16QAM	1	99	22.11	22.21	22.34	22	2
20	16QAM	50	0	21.10	21.17	21.22		
20	16QAM	50	24	21.02	21.02	21.13		
20	16QAM	50	50	21.02	20.99	21.16	22	2
20	16QAM	100	0	21.01	21.04	21.14		
20	64QAM	1	0	21.43	21.37	21.40		
20	64QAM	1	49	21.07	21.09	21.27	22	2
20	64QAM	1	99	21.19	21.12	21.26		
20	64QAM	50	0	20.09	20.13	20.26		
20	64QAM	50	24	20.01	20.06	20.16	21	3
20	64QAM	50	50	20.03	19.96	20.18		
20	64QAM	100	0	20.01	20.05	20.13		
Channel				20025	20175	20325	Tune-up limit (dBm)	MPR (dB)
Frequency (MHz)				1717.5	1732.5	1747.5		
15	QPSK	1	0	23.10	23.12	23.22	24	0
15	QPSK	1	37	22.89	22.90	22.99		
15	QPSK	1	74	22.93	22.94	23.06		
15	QPSK	36	0	22.04	22.13	22.13	23	1
15	QPSK	36	20	21.99	22.07	22.12		
15	QPSK	36	39	22.02	21.99	22.16		
15	QPSK	75	0	21.98	22.03	22.07	23	1
15	16QAM	1	0	22.38	22.48	22.44		
15	16QAM	1	37	22.21	22.18	22.31		
15	16QAM	1	74	22.21	22.30	22.40	22	2
15	16QAM	36	0	21.04	21.10	21.16		
15	16QAM	36	20	20.95	21.04	21.07		
15	16QAM	36	39	21.00	20.99	21.14	22	2
15	16QAM	75	0	20.97	21.06	21.11		
15	64QAM	1	0	21.26	21.42	21.53		
15	64QAM	1	37	20.99	21.17	21.31	22	2
15	64QAM	1	74	21.07	21.26	21.35		
15	64QAM	36	0	20.05	20.12	20.16		
15	64QAM	36	20	20.01	20.06	20.12	21	3
15	64QAM	36	39	20.04	19.97	20.20		
15	64QAM	75	0	19.97	20.05	20.11		



Channel				20000	20175	20350	Tune-up limit (dBm)	MPR (dB)
Frequency (MHz)				1715	1732.5	1750		
10	QPSK	1	0	22.92	23.10	23.13	24	0
10	QPSK	1	25	22.83	22.94	23.10		
10	QPSK	1	49	22.73	22.93	23.07		
10	QPSK	25	0	21.88	22.03	22.10	23	1
10	QPSK	25	12	21.83	22.02	22.19		
10	QPSK	25	25	21.80	21.96	22.11		
10	QPSK	50	0	21.84	21.99	22.17	23	1
10	16QAM	1	0	22.16	22.31	22.38		
10	16QAM	1	25	22.08	22.17	22.39		
10	16QAM	1	49	22.06	22.14	22.36	22	2
10	16QAM	25	0	20.89	21.05	21.05		
10	16QAM	25	12	20.90	21.01	21.14		
10	16QAM	25	25	20.81	20.99	21.13	22	2
10	16QAM	50	0	20.87	20.99	21.15		
10	64QAM	1	0	21.09	21.19	21.33		
10	64QAM	1	25	20.94	21.03	21.33	22	2
10	64QAM	1	49	20.89	20.99	21.23		
10	64QAM	25	0	19.93	20.08	20.09		
10	64QAM	25	12	19.89	20.03	20.18	21	3
10	64QAM	25	25	19.91	19.97	20.13		
10	64QAM	50	0	19.94	20.02	20.17		
Channel				19975	20175	20375	Tune-up limit (dBm)	MPR (dB)
Frequency (MHz)				1712.5	1732.5	1752.5		
5	QPSK	1	0	22.86	23.00	23.12	24	0
5	QPSK	1	12	22.82	22.95	23.10		
5	QPSK	1	24	22.80	22.93	23.08		
5	QPSK	12	0	21.88	22.01	22.10	23	1
5	QPSK	12	7	21.83	21.99	22.12		
5	QPSK	12	13	21.81	21.94	22.09		
5	QPSK	25	0	21.84	21.99	22.10	23	1
5	16QAM	1	0	22.11	22.22	22.43		
5	16QAM	1	12	22.10	22.18	22.36		
5	16QAM	1	24	22.04	22.11	22.34	22	2
5	16QAM	12	0	20.86	21.01	21.14		
5	16QAM	12	7	20.89	20.99	21.15		
5	16QAM	12	13	20.80	20.97	21.12	22	2
5	16QAM	25	0	20.81	20.96	21.14		
5	64QAM	1	0	21.06	21.20	21.32		
5	64QAM	1	12	21.00	21.13	21.22	22	2
5	64QAM	1	24	20.98	21.07	21.24		
5	64QAM	12	0	19.91	20.03	20.17		
5	64QAM	12	7	19.91	20.04	20.20	21	3
5	64QAM	12	13	19.96	20.02	20.16		
5	64QAM	25	0	19.89	19.99	20.16		



Channel				19965	20175	20385	Tune-up limit (dBm)	MPR (dB)
Frequency (MHz)				1711.5	1732.5	1753.5		
3	QPSK	1	0	22.90	22.93	23.09	24	0
3	QPSK	1	8	22.80	22.97	23.14		
3	QPSK	1	14	23.01	23.00	23.02		
3	QPSK	8	0	22.05	22.13	22.10	23	1
3	QPSK	8	4	22.05	22.15	22.08		
3	QPSK	8	7	21.88	21.94	22.03		
3	QPSK	15	0	21.91	21.95	22.11	23	1
3	16QAM	1	0	22.22	22.18	22.32		
3	16QAM	1	8	22.28	22.27	22.48		
3	16QAM	1	14	22.13	22.15	22.33	22	2
3	16QAM	8	0	20.99	20.99	21.17		
3	16QAM	8	4	20.97	21.03	21.17		
3	16QAM	8	7	20.94	20.97	21.12	22	2
3	16QAM	15	0	20.92	20.94	21.11		
3	64QAM	1	0	21.10	21.11	21.23		
3	64QAM	1	8	21.16	21.21	21.35	22	2
3	64QAM	1	14	21.03	21.04	21.21		
3	64QAM	8	0	19.95	19.99	20.17		
3	64QAM	8	4	19.95	20.04	20.15	21	3
3	64QAM	8	7	19.92	19.99	20.11		
3	64QAM	15	0	19.95	19.97	20.07		
Channel				19957	20175	20393	Tune-up limit (dBm)	MPR (dB)
Frequency (MHz)				1710.7	1732.5	1754.3		
1.4	QPSK	1	0	22.81	22.83	22.97	24	0
1.4	QPSK	1	3	22.79	22.89	23.03		
1.4	QPSK	1	5	22.77	22.81	22.97		
1.4	QPSK	3	0	22.83	22.87	23.04	23	1
1.4	QPSK	3	1	22.89	22.92	23.07		
1.4	QPSK	3	3	22.83	22.93	23.07		
1.4	QPSK	6	0	21.80	21.89	22.03	23	1
1.4	16QAM	1	0	22.04	22.03	22.28	23	1
1.4	16QAM	1	3	22.09	22.10	22.23		
1.4	16QAM	1	5	22.04	21.99	22.15		
1.4	16QAM	3	0	21.89	21.85	22.07	23	1
1.4	16QAM	3	1	21.89	21.90	22.12		
1.4	16QAM	3	3	21.88	21.90	22.11		
1.4	16QAM	6	0	20.86	20.96	21.09	22	2
1.4	64QAM	1	0	21.05	21.02	21.23	22	2
1.4	64QAM	1	3	21.03	21.07	21.27		
1.4	64QAM	1	5	21.15	21.00	21.22		
1.4	64QAM	3	0	21.26	21.50	21.16	22	2
1.4	64QAM	3	1	21.04	21.04	21.25		
1.4	64QAM	3	3	21.04	21.05	21.19		
1.4	64QAM	6	0	20.15	20.10	20.06	21	3





<LTE Band 5>

BW [MHz]	Modulation	RB Size	RB Offset	Power Low Ch. / Freq.	Power Middle Ch. / Freq.	Power High Ch. / Freq.	Tune-up limit (dBm)	MPR (dB)
Channel				20450	20525	20600		
Frequency (MHz)				829	836.5	844		
10	QPSK	1	0	22.86	22.88	22.99	24	0
10	QPSK	1	25	22.83	23.00	23.30		
10	QPSK	1	49	22.80	22.97	22.99		
10	QPSK	25	0	22.05	22.03	22.04	23	1
10	QPSK	25	12	22.03	22.00	22.01		
10	QPSK	25	25	22.02	21.92	22.07		
10	QPSK	50	0	21.97	21.94	22.10	23	1
10	16QAM	1	0	22.17	22.13	22.37		
10	16QAM	1	25	22.15	22.20	22.27		
10	16QAM	1	49	22.20	22.19	22.32	22	2
10	16QAM	25	0	20.97	20.86	21.01		
10	16QAM	25	12	20.98	20.95	21.03		
10	16QAM	25	25	21.03	20.89	21.07	22	2
10	16QAM	50	0	21.01	20.96	21.11		
10	64QAM	1	0	21.11	21.07	21.25		
10	64QAM	1	25	21.04	21.11	21.14	22	2
10	64QAM	1	49	21.10	21.11	21.19		
10	64QAM	25	0	20.02	19.93	20.02		
10	64QAM	25	12	20.01	19.96	20.06	21	3
10	64QAM	25	25	20.01	19.93	20.07		
10	64QAM	50	0	19.98	19.94	20.12		
Channel				20425	20525	20625	Tune-up limit (dBm)	MPR (dB)
Frequency (MHz)				826.5	836.5	846.5		
5	QPSK	1	0	22.78	22.84	22.96	24	0
5	QPSK	1	12	22.86	22.88	22.99		
5	QPSK	1	24	22.82	22.86	22.99		
5	QPSK	12	0	21.77	21.97	22.07	23	1
5	QPSK	12	7	21.87	21.95	22.07		
5	QPSK	12	13	21.86	21.91	22.06		
5	QPSK	25	0	21.85	21.96	22.06	23	1
5	16QAM	1	0	22.10	22.11	22.21		
5	16QAM	1	12	22.11	22.17	22.29		
5	16QAM	1	24	22.02	22.17	22.27	22	2
5	16QAM	12	0	20.81	20.97	21.09		
5	16QAM	12	7	20.91	21.00	21.09		
5	16QAM	12	13	20.85	20.96	21.04	22	2
5	16QAM	25	0	20.88	20.94	21.05		
5	64QAM	1	0	20.96	20.99	21.16		
5	64QAM	1	12	21.02	21.05	21.18	22	2
5	64QAM	1	24	21.00	21.02	21.19		
5	64QAM	12	0	19.84	20.05	20.13		
5	64QAM	12	7	19.96	19.99	20.12	21	3
5	64QAM	12	13	19.94	19.95	20.13		
5	64QAM	25	0	19.92	19.99	20.07		



Channel				20415	20525	20635	Tune-up limit (dBm)	MPR (dB)
Frequency (MHz)				825.5	836.5	847.5		
3	QPSK	1	0	22.75	22.97	23.03	24	0
3	QPSK	1	8	22.85	22.96	23.06		
3	QPSK	1	14	22.81	22.86	22.94		
3	QPSK	8	0	21.76	21.88	21.93	23	1
3	QPSK	8	4	21.78	21.91	21.98		
3	QPSK	8	7	21.89	21.89	21.94		
3	QPSK	15	0	21.74	21.93	21.98	23	1
3	16QAM	1	0	22.04	22.27	22.28		
3	16QAM	1	8	22.09	22.29	22.36		
3	16QAM	1	14	22.02	22.23	22.27	22	2
3	16QAM	8	0	20.83	20.99	21.00		
3	16QAM	8	4	20.85	21.00	21.02		
3	16QAM	8	7	20.95	20.97	20.98	22	2
3	16QAM	15	0	20.79	20.94	20.93		
3	64QAM	1	0	20.91	21.10	21.06		
3	64QAM	1	8	21.02	21.18	21.13	22	2
3	64QAM	1	14	21.02	21.05	21.03		
3	64QAM	8	0	19.84	20.01	19.97		
3	64QAM	8	4	19.84	19.97	19.99	21	3
3	64QAM	8	7	19.92	19.94	19.98		
3	64QAM	15	0	19.81	19.90	19.94		
Channel				20407	20525	20643	Tune-up limit (dBm)	MPR (dB)
Frequency (MHz)				824.7	836.5	848.3		
1.4	QPSK	1	0	23.25	22.83	22.91	24	0
1.4	QPSK	1	3	22.72	22.92	22.98		
1.4	QPSK	1	5	22.80	22.85	22.91		
1.4	QPSK	3	0	22.73	22.84	22.95		
1.4	QPSK	3	1	22.77	22.92	23.01		
1.4	QPSK	3	3	22.76	22.90	23.05	23	1
1.4	QPSK	6	0	21.74	21.85	21.95	23	1
1.4	16QAM	1	0	21.92	22.16	22.19		
1.4	16QAM	1	3	22.01	22.20	22.19		
1.4	16QAM	1	5	21.87	22.16	22.12		
1.4	16QAM	3	0	21.77	21.86	21.94		
1.4	16QAM	3	1	21.82	21.94	21.99	23	1
1.4	16QAM	3	3	21.76	21.91	21.95		
1.4	16QAM	6	0	20.76	20.94	20.96		
1.4	64QAM	1	0	21.11	21.30	21.40		
1.4	64QAM	1	3	21.14	21.36	21.54		
1.4	64QAM	1	5	21.07	21.27	21.42	22	2
1.4	64QAM	3	0	21.12	21.30	21.39		
1.4	64QAM	3	1	21.16	21.28	21.42		
1.4	64QAM	3	3	21.13	21.26	21.46		
1.4	64QAM	6	0	20.05	20.17	20.25		
1.4	64QAM	6	0	20.05	20.17	20.25	21	3



<LTE Band 7>

BW [MHz]	Modulation	RB Size	RB Offset	Power Low Ch. / Freq.	Power Middle Ch. / Freq.	Power High Ch. / Freq.	Tune-up limit (dBm)	MPR (dB)
Channel				20850	21100	21350		
Frequency (MHz)				2510	2535	2560		
20	QPSK	1	0	22.95	22.88	22.90	24	0
20	QPSK	1	49	22.79	22.75	22.73		
20	QPSK	1	99	22.84	22.74	22.75		
20	QPSK	50	0	21.89	21.88	21.88	23	1
20	QPSK	50	24	21.84	21.84	21.84		
20	QPSK	50	50	21.83	21.77	21.79		
20	QPSK	100	0	21.89	21.83	21.83		
20	16QAM	1	0	22.28	22.15	22.16	23	1
20	16QAM	1	49	22.07	21.99	21.99		
20	16QAM	1	99	22.00	21.99	22.02		
20	16QAM	50	0	20.95	20.86	20.91	22	2
20	16QAM	50	24	20.89	20.84	20.88		
20	16QAM	50	50	20.84	20.80	20.82		
20	16QAM	100	0	20.87	20.79	20.84		
20	64QAM	1	0	21.10	21.19	21.20	22	2
20	64QAM	1	49	21.07	20.99	21.02		
20	64QAM	1	99	20.95	20.98	20.90		
20	64QAM	50	0	19.94	19.88	19.91	21	3
20	64QAM	50	24	19.92	19.86	19.86		
20	64QAM	50	50	19.85	19.78	19.83		
20	64QAM	100	0	19.87	19.82	19.88		
Channel				20825	21100	21375	Tune-up limit (dBm)	MPR (dB)
Frequency (MHz)				2507.5	2535	2562.5		
15	QPSK	1	0	22.92	22.86	22.88	24	0
15	QPSK	1	37	22.79	22.74	22.76		
15	QPSK	1	74	22.79	22.73	22.80		
15	QPSK	36	0	21.89	21.84	21.84	23	1
15	QPSK	36	20	21.84	21.83	21.87		
15	QPSK	36	39	21.81	21.81	21.82		
15	QPSK	75	0	21.84	21.81	21.85		
15	16QAM	1	0	22.17	22.13	22.16	23	1
15	16QAM	1	37	22.07	22.05	22.08		
15	16QAM	1	74	22.05	22.04	22.06		
15	16QAM	36	0	20.89	20.85	20.88	22	2
15	16QAM	36	20	20.87	20.84	20.84		
15	16QAM	36	39	20.81	20.78	20.81		
15	16QAM	75	0	20.85	20.79	20.83		
15	64QAM	1	0	21.09	21.00	21.01	22	2
15	64QAM	1	37	20.99	20.82	20.91		
15	64QAM	1	74	20.94	20.89	20.92		
15	64QAM	36	0	19.88	19.88	19.89	21	3
15	64QAM	36	20	19.91	19.85	19.88		
15	64QAM	36	39	19.83	19.80	19.83		
15	64QAM	75	0	19.85	19.79	19.84		



Channel				20800	21100	21400	Tune-up limit (dBm)	MPR (dB)		
Frequency (MHz)				2505	2535	2565				
10	QPSK	1	0	22.85	22.80	22.84	24	0		
10	QPSK	1	25	22.76	22.76	22.79				
10	QPSK	1	49	22.75	22.72	22.78				
10	QPSK	25	0	21.85	21.82	21.83	23	1		
10	QPSK	25	12	21.84	21.81	21.84				
10	QPSK	25	25	21.79	21.77	21.81				
10	QPSK	50	0	21.83	21.78	21.86	23	1		
10	16QAM	1	0	22.16	22.11	22.13				
10	16QAM	1	25	22.12	22.08	22.11				
10	16QAM	1	49	22.09	22.02	22.08	22	2		
10	16QAM	25	0	20.87	20.81	20.87				
10	16QAM	25	12	20.86	20.81	20.89				
10	16QAM	25	25	20.80	20.78	20.86	22	2		
10	16QAM	50	0	20.86	20.81	20.82				
10	64QAM	1	0	20.99	20.94	20.94				
10	64QAM	1	25	20.93	20.89	20.90	22	2		
10	64QAM	1	49	20.93	20.85	20.93				
10	64QAM	25	0	19.87	19.84	19.88				
10	64QAM	25	12	19.91	19.89	19.89	21	3		
10	64QAM	25	25	19.82	19.83	19.85				
10	64QAM	25	25	19.82	19.83	19.85				
10	64QAM	50	0	19.87	19.82	19.85	21	3		
Channel				20775	21100	21425			Tune-up limit (dBm)	MPR (dB)
Frequency (MHz)				2502.5	2535	2567.5				
5	QPSK	1	0	22.79	22.79	22.78	24	0		
5	QPSK	1	12	22.82	22.73	22.76				
5	QPSK	1	24	22.78	22.73	22.81				
5	QPSK	12	0	21.82	21.80	21.85	23	1		
5	QPSK	12	7	21.89	21.83	21.88				
5	QPSK	12	13	21.84	21.79	21.85				
5	QPSK	25	0	21.83	21.78	21.86	23	1		
5	16QAM	1	0	22.05	22.06	22.04				
5	16QAM	1	12	22.04	22.04	22.05				
5	16QAM	1	24	22.01	21.96	22.03	22	2		
5	16QAM	12	0	20.83	20.81	20.84				
5	16QAM	12	7	20.89	20.81	20.86				
5	16QAM	12	13	20.87	20.78	20.87	22	2		
5	16QAM	25	0	20.85	20.78	20.81				
5	64QAM	1	0	21.00	21.00	21.01				
5	64QAM	1	12	20.94	20.97	21.01	22	2		
5	64QAM	1	24	20.94	20.93	20.99				
5	64QAM	12	0	19.93	19.83	19.87				
5	64QAM	12	7	19.92	19.86	19.90	21	3		
5	64QAM	12	13	19.91	19.84	19.91				
5	64QAM	25	0	19.85	19.78	19.84				



<LTE Band 13>

BW [MHz]	Modulation	RB Size	RB Offset	Power Low Ch. / Freq.	Power Middle Ch. / Freq.	Power High Ch. / Freq.	Tune-up limit (dBm)	MPR (dB)
Channel				23230				
Frequency (MHz)				782				
10	QPSK	1	0		23.00		24	0
10	QPSK	1	25		22.85			
10	QPSK	1	49		22.78			
10	QPSK	25	0		21.92		23	1
10	QPSK	25	12		21.91			
10	QPSK	25	25		21.86			
10	QPSK	50	0		21.89		23	1
10	16QAM	1	0		22.13			
10	16QAM	1	25		22.07			
10	16QAM	1	49		21.97		22	2
10	16QAM	25	0		20.95			
10	16QAM	25	12		20.91			
10	16QAM	25	25		20.86		22	2
10	16QAM	50	0		20.90			
10	64QAM	1	0		21.16			
10	64QAM	1	25		21.07		22	2
10	64QAM	1	49		20.97			
10	64QAM	25	0		19.98			
10	64QAM	25	12		19.94		21	3
10	64QAM	25	25		19.84			
10	64QAM	50	0		19.90			
Channel				23205	23230	23255	Tune-up limit (dBm)	MPR (dB)
Frequency (MHz)				779.5	782	784.5		
5	QPSK	1	0	22.93	22.88	22.97	24	0
5	QPSK	1	12	22.88	22.80	22.90		
5	QPSK	1	24	22.86	22.82	22.72		
5	QPSK	12	0	21.94	21.91	21.99	23	1
5	QPSK	12	7	21.92	21.92	21.93		
5	QPSK	12	13	21.92	21.86	21.92		
5	QPSK	25	0	21.89	21.84	21.91	23	1
5	16QAM	1	0	22.25	22.16	22.25		
5	16QAM	1	12	22.11	22.11	22.16		
5	16QAM	1	24	22.16	22.09	22.14	22	2
5	16QAM	12	0	20.96	20.92	21.00		
5	16QAM	12	7	20.92	20.92	21.00		
5	16QAM	12	13	20.92	20.89	20.91	22	2
5	16QAM	25	0	20.93	20.86	20.95		
5	64QAM	1	0	21.17	21.05	21.13		
5	64QAM	1	12	21.02	21.02	21.08	22	2
5	64QAM	1	24	21.03	20.97	21.04		
5	64QAM	12	0	19.96	19.92	20.00		
5	64QAM	12	7	19.99	19.92	20.02	21	3
5	64QAM	12	13	19.97	19.90	20.00		
5	64QAM	25	0	19.94	19.87	19.96		



<LTE Band 66>

BW [MHz]	Modulation	RB Size	RB Offset	Power Low Ch. / Freq.	Power Middle Ch. / Freq.	Power High Ch. / Freq.	Tune-up limit (dBm)	MPR (dB)
Channel				132072	132322	132572		
Frequency (MHz)				1720	1745	1770		
20	QPSK	1	0	22.83	22.95	23.10		
20	QPSK	1	49	22.87	22.80	22.83	24	0
20	QPSK	1	99	22.71	22.74	22.88		
20	QPSK	50	0	21.85	22.01	22.03		
20	QPSK	50	24	21.79	21.91	21.95	23	1
20	QPSK	50	50	21.82	21.82	21.86		
20	QPSK	100	0	21.80	21.92	21.95		
20	16QAM	1	0	22.22	22.20	22.49	23	1
20	16QAM	1	49	21.93	22.10	22.16		
20	16QAM	1	99	21.95	22.02	21.99		
20	16QAM	50	0	20.91	21.05	21.07	22	2
20	16QAM	50	24	20.83	20.96	20.95		
20	16QAM	50	50	20.81	20.87	20.83		
20	16QAM	100	0	20.79	20.96	20.99	22	2
20	64QAM	1	0	21.20	21.20	21.28		
20	64QAM	1	49	20.93	21.08	20.98		
20	64QAM	1	99	20.92	20.95	20.86	21	3
20	64QAM	50	0	19.91	20.08	20.08		
20	64QAM	50	24	19.83	19.96	19.96		
20	64QAM	50	50	19.82	19.88	19.87	21	3
20	64QAM	100	0	19.81	19.93	19.98		
Channel				132047	132322	132597		
Frequency (MHz)				1717.5	1745	1772.5	Tune-up limit (dBm)	MPR (dB)
15	QPSK	1	0	22.92	23.03	23.04	24	0
15	QPSK	1	37	22.79	22.81	22.82		
15	QPSK	1	74	22.74	22.78	22.73		
15	QPSK	36	0	21.86	22.02	22.02	23	1
15	QPSK	36	20	21.78	21.96	21.95		
15	QPSK	36	39	21.76	21.84	21.86		
15	QPSK	75	0	21.82	21.93	21.93	23	1
15	16QAM	1	0	22.16	22.30	22.35		
15	16QAM	1	37	21.93	22.06	22.10		
15	16QAM	1	74	21.97	22.06	21.99	22	2
15	16QAM	36	0	20.84	20.98	21.04		
15	16QAM	36	20	20.79	20.92	20.97		
15	16QAM	36	39	20.72	20.86	20.86	22	2
15	16QAM	75	0	20.80	20.95	20.94		
15	64QAM	1	0	21.17	21.25	21.33		
15	64QAM	1	37	20.89	21.04	21.04	22	2
15	64QAM	1	74	20.96	20.96	20.98		
15	64QAM	36	0	19.89	20.06	20.04		
15	64QAM	36	20	19.85	20.00	19.94	21	3
15	64QAM	36	39	19.78	19.88	19.89		
15	64QAM	75	0	19.79	19.89	19.96		



Channel				132022	132322	132622	Tune-up limit (dBm)	MPR (dB)
Frequency (MHz)				1715	1745	1775		
10	QPSK	1	0	22.85	22.98	22.97	24	0
10	QPSK	1	25	22.74	22.86	22.88		
10	QPSK	1	49	22.75	22.81	22.78		
10	QPSK	25	0	21.83	21.95	21.95	23	1
10	QPSK	25	12	21.82	21.88	21.93		
10	QPSK	25	25	21.72	21.89	21.87		
10	QPSK	50	0	21.80	21.89	21.92	23	1
10	16QAM	1	0	22.08	22.29	22.20		
10	16QAM	1	25	21.99	22.12	22.05		
10	16QAM	1	49	21.98	22.11	21.97	22	2
10	16QAM	25	0	20.80	20.95	20.94		
10	16QAM	25	12	20.80	20.93	20.92		
10	16QAM	25	25	20.78	20.86	20.86	22	2
10	16QAM	50	0	20.81	20.91	20.92		
10	64QAM	1	0	21.06	21.09	21.10		
10	64QAM	1	25	20.95	21.07	20.97	22	2
10	64QAM	1	49	20.87	20.96	20.94		
10	64QAM	25	0	19.85	19.98	19.97		
10	64QAM	25	12	19.84	19.93	19.95	21	3
10	64QAM	25	25	19.74	19.90	19.85		
10	64QAM	50	0	19.79	19.92	19.90		
Channel				131997	132322	132647	Tune-up limit (dBm)	MPR (dB)
Frequency (MHz)				1712.5	1745	1777.5		
5	QPSK	1	0	22.79	22.90	22.90	24	0
5	QPSK	1	12	22.73	22.86	22.83		
5	QPSK	1	24	22.72	22.84	22.80		
5	QPSK	12	0	21.83	21.91	21.94	23	1
5	QPSK	12	7	21.77	21.94	21.89		
5	QPSK	12	13	21.74	21.84	21.83		
5	QPSK	25	0	21.77	21.89	21.88	23	1
5	16QAM	1	0	21.99	22.15	22.09		
5	16QAM	1	12	21.98	22.13	22.06		
5	16QAM	1	24	21.98	22.10	22.00	22	2
5	16QAM	12	0	20.80	20.90	20.93		
5	16QAM	12	7	20.84	20.94	20.91		
5	16QAM	12	13	20.81	20.90	20.85	22	2
5	16QAM	25	0	20.80	20.92	20.88		
5	64QAM	1	0	20.99	21.14	21.12		
5	64QAM	1	12	20.87	21.02	21.03	22	2
5	64QAM	1	24	20.87	21.02	20.97		
5	64QAM	12	0	19.86	19.95	19.93		
5	64QAM	12	7	19.85	19.95	19.91	21	3
5	64QAM	12	13	19.81	19.93	19.92		
5	64QAM	25	0	19.79	19.88	19.87		



Channel				131987	132322	132657	Tune-up limit (dBm)	MPR (dB)
Frequency (MHz)				1711.5	1745	1778.5		
3	QPSK	1	0	22.78	22.87	22.70	24	0
3	QPSK	1	8	22.85	22.92	22.80		
3	QPSK	1	14	22.78	22.79	22.76		
3	QPSK	8	0	21.71	21.74	21.76	23	1
3	QPSK	8	4	21.76	21.75	21.79		
3	QPSK	8	7	21.72	21.89	21.73		
3	QPSK	15	0	21.76	21.86	21.75	23	1
3	16QAM	1	0	21.97	22.13	21.99		
3	16QAM	1	8	22.11	22.25	22.06		
3	16QAM	1	14	21.96	22.12	21.91	22	2
3	16QAM	8	0	20.84	20.91	20.81		
3	16QAM	8	4	20.84	20.92	20.82		
3	16QAM	8	7	20.81	20.92	20.78	22	2
3	16QAM	15	0	20.75	20.89	20.77		
3	64QAM	1	0	20.93	21.01	20.89		
3	64QAM	1	8	20.93	21.10	20.97	22	2
3	64QAM	1	14	20.85	20.99	20.90		
3	64QAM	8	0	19.82	19.93	19.81		
3	64QAM	8	4	19.83	19.93	19.80	21	3
3	64QAM	8	7	19.80	19.91	19.78		
3	64QAM	15	0	19.75	19.90	19.76		
Channel				131979	132322	132665	Tune-up limit (dBm)	MPR (dB)
Frequency (MHz)				1710.7	1745	1779.3		
1.4	QPSK	1	0	22.72	22.77	22.76	24	0
1.4	QPSK	1	3	22.78	22.84	22.78		
1.4	QPSK	1	5	22.76	22.76	22.77		
1.4	QPSK	3	0	22.72	22.85	22.80	23	1
1.4	QPSK	3	1	22.79	22.91	22.91		
1.4	QPSK	3	3	22.78	22.90	22.86		
1.4	QPSK	6	0	22.70	21.85	21.78	23	1
1.4	16QAM	1	0	21.91	22.03	21.90		
1.4	16QAM	1	3	22.02	22.13	21.94		
1.4	16QAM	1	5	21.92	22.04	21.88	23	1
1.4	16QAM	3	0	21.70	21.88	21.84		
1.4	16QAM	3	1	21.77	21.93	21.90		
1.4	16QAM	3	3	21.74	21.91	21.82	22	2
1.4	16QAM	6	0	20.77	20.89	20.86		
1.4	64QAM	1	0	21.03	21.28	21.24		
1.4	64QAM	1	3	21.10	21.24	21.24	22	2
1.4	64QAM	1	5	21.07	21.19	21.19		
1.4	64QAM	3	0	21.00	21.12	21.13		
1.4	64QAM	3	1	21.10	21.16	21.19	22	2
1.4	64QAM	3	3	21.11	21.17	21.18		
1.4	64QAM	6	0	20.19	20.04	20.08		
1.4	64QAM	6	0	20.19	20.04	20.08	21	3





**<Reduced Power Mode for Hotspot On/P-Sensor On>**

**<LTE Band 5>**

BW [MHz]	Modulation	RB Size	RB Offset	Power Low Ch. / Freq.	Power Middle Ch. / Freq.	Power High Ch. / Freq.	Tune-up limit (dBm)	MPR (dB)
Channel				20450	20525	20600		
Frequency (MHz)				829	836.5	844		
10	QPSK	1	0	20.74	20.70	20.96	21.8	0
10	QPSK	1	25	20.85	20.76	21.02		
10	QPSK	1	49	20.60	20.59	20.95		
10	QPSK	25	0	20.78	20.85	20.97	21.8	0
10	QPSK	25	12	20.84	20.97	20.97		
10	QPSK	25	25	20.88	20.86	21.02		
10	QPSK	50	0	20.80	20.90	21.03	21.8	0
10	16QAM	1	0	21.04	21.11	21.31		
10	16QAM	1	25	21.05	21.16	21.21		
10	16QAM	1	49	21.03	21.18	21.28	21.8	0
10	16QAM	25	0	20.85	20.86	21.02		
10	16QAM	25	12	20.84	20.92	20.99		
10	16QAM	25	25	20.90	20.87	21.04	21.8	0
10	16QAM	50	0	20.82	20.93	21.08		
10	64QAM	1	0	20.91	21.05	21.20		
10	64QAM	1	25	20.89	21.06	21.09	21.8	0
10	64QAM	1	49	21.00	21.06	21.14		
10	64QAM	25	0	20.09	20.10	20.23		
10	64QAM	25	12	20.08	20.18	20.21	21.8	0
10	64QAM	25	25	20.11	20.10	20.26		
10	64QAM	50	0	20.05	20.16	20.31		
Channel				20425	20525	20625	Tune-up limit (dBm)	MPR (dB)
Frequency (MHz)				826.5	836.5	846.5		
5	QPSK	1	0	20.64	20.79	20.82	21.8	0
5	QPSK	1	12	20.56	20.58	20.80		
5	QPSK	1	24	20.60	20.60	20.55		
5	QPSK	12	0	20.60	20.94	20.80	21.8	0
5	QPSK	12	7	20.66	20.90	20.92		
5	QPSK	12	13	20.72	20.92	20.90		
5	QPSK	25	0	20.73	20.90	20.90	21.8	0
5	16QAM	1	0	20.84	21.08	21.11		
5	16QAM	1	12	20.90	21.15	21.15		
5	16QAM	1	24	20.88	21.13	21.24	21.8	0
5	16QAM	12	0	20.69	20.95	20.93		
5	16QAM	12	7	20.78	20.94	20.94		
5	16QAM	12	13	20.73	20.90	20.90	21.8	0
5	16QAM	25	0	20.76	20.92	20.91		
5	64QAM	1	0	20.83	21.01	21.01		
5	64QAM	1	12	20.85	21.05	21.09	21.8	0
5	64QAM	1	24	20.85	21.01	21.08		
5	64QAM	12	0	19.92	20.15	20.18		
5	64QAM	12	7	20.04	20.18	20.21	21.8	0
5	64QAM	12	13	20.01	20.14	20.18		
5	64QAM	25	0	19.98	20.10	20.12		



Channel				20415	20525	20635	Tune-up limit (dBm)	MPR (dB)
Frequency (MHz)				825.5	836.5	847.5		
3	QPSK	1	0	20.65	20.84	20.87	21.8	0
3	QPSK	1	8	20.85	20.92	20.92		
3	QPSK	1	14	20.69	20.78	20.81		
3	QPSK	8	0	20.63	20.80	20.90	21.8	0
3	QPSK	8	4	20.67	20.89	20.91		
3	QPSK	8	7	20.76	20.87	20.89		
3	QPSK	15	0	20.60	20.86	20.88	21.8	0
3	16QAM	1	0	20.88	21.16	21.17		
3	16QAM	1	8	20.92	21.22	21.26		
3	16QAM	1	14	20.86	21.14	21.20	21.8	0
3	16QAM	8	0	20.73	20.96	20.97		
3	16QAM	8	4	20.72	20.98	20.99		
3	16QAM	8	7	20.77	20.94	20.96	21.8	0
3	16QAM	15	0	20.67	20.92	20.90		
3	64QAM	1	0	20.79	21.05	21.10		
3	64QAM	1	8	20.87	21.13	21.21	21.8	0
3	64QAM	1	14	20.84	21.03	21.03		
3	64QAM	8	0	19.91	20.16	20.15		
3	64QAM	8	4	19.92	20.17	20.16	21.8	0
3	64QAM	8	7	20.02	20.13	20.14		
3	64QAM	15	0	19.84	20.11	20.12		
Channel				20407	20525	20643	Tune-up limit (dBm)	MPR (dB)
Frequency (MHz)				824.7	836.5	848.3		
1.4	QPSK	1	0	20.54	20.73	20.78	21.8	0
1.4	QPSK	1	3	20.58	20.80	20.81		
1.4	QPSK	1	5	20.52	20.74	20.73		
1.4	QPSK	3	0	20.57	20.82	20.81	21.8	0
1.4	QPSK	3	1	20.62	20.87	20.85		
1.4	QPSK	3	3	20.61	20.84	20.85		
1.4	QPSK	6	0	20.59	20.85	20.81	21.8	0
1.4	16QAM	1	0	20.80	21.13	21.12	21.8	0
1.4	16QAM	1	3	20.85	21.13	21.22		
1.4	16QAM	1	5	20.73	21.03	21.12		
1.4	16QAM	3	0	20.56	20.85	20.85	21.8	0
1.4	16QAM	3	1	20.63	20.89	20.92		
1.4	16QAM	3	3	20.60	20.89	20.92		
1.4	16QAM	6	0	20.64	20.89	20.89	21.8	0
1.4	64QAM	1	0	20.76	20.97	21.05	21.8	0
1.4	64QAM	1	3	20.79	21.03	21.11		
1.4	64QAM	1	5	20.73	20.99	21.02		
1.4	64QAM	3	0	20.75	20.99	21.03	21.8	0
1.4	64QAM	3	1	20.81	21.05	21.04		
1.4	64QAM	3	3	20.78	21.02	21.03		
1.4	64QAM	6	0	19.81	20.04	20.00	21.8	0



<LTE Band 7>

BW [MHz]	Modulation	RB Size	RB Offset	Power Low Ch. / Freq.	Power Middle Ch. / Freq.	Power High Ch. / Freq.	Tune-up limit (dBm)	MPR (dB)
Channel				20850	21100	21350		
Frequency (MHz)				2510	2535	2560		
20	QPSK	1	0	15.27	15.16	15.21	16.2	0
20	QPSK	1	49	15.04	15.02	15.08		
20	QPSK	1	99	15.03	15.08	15.08		
20	QPSK	50	0	15.25	15.11	15.22	16.2	0
20	QPSK	50	24	15.16	15.09	15.22		
20	QPSK	50	50	15.10	15.05	15.16		
20	QPSK	100	0	15.20	15.07	15.17	16.2	0
20	16QAM	1	0	15.55	15.40	15.50		
20	16QAM	1	49	15.33	15.30	15.37		
20	16QAM	1	99	15.20	15.27	15.36	16.2	0
20	16QAM	50	0	15.22	15.13	15.26		
20	16QAM	50	24	15.16	15.11	15.25		
20	16QAM	50	50	15.13	15.04	15.15	16.2	0
20	16QAM	100	0	15.11	15.07	15.19		
20	64QAM	1	0	15.44	15.41	15.39		
20	64QAM	1	49	15.30	15.17	15.27	16.2	0
20	64QAM	1	99	15.19	15.23	15.27		
20	64QAM	50	0	15.23	15.13	15.29		
20	64QAM	50	24	15.17	15.11	15.22	16.2	0
20	64QAM	50	50	15.17	15.12	15.21		
20	64QAM	100	0	15.19	15.09	15.23		
Channel				20825	21100	21375	Tune-up limit (dBm)	MPR (dB)
Frequency (MHz)				2507.5	2535	2562.5		
15	QPSK	1	0	15.14	15.09	15.22	16.2	0
15	QPSK	1	37	15.02	15.03	15.08		
15	QPSK	1	74	15.05	15.03	15.10		
15	QPSK	36	0	15.15	15.11	15.22	16.2	0
15	QPSK	36	20	15.11	15.12	15.19		
15	QPSK	36	39	15.06	15.04	15.17		
15	QPSK	75	0	15.11	15.08	15.19	16.2	0
15	16QAM	1	0	15.42	15.39	15.45		
15	16QAM	1	37	15.34	15.27	15.34		
15	16QAM	1	74	15.28	15.26	15.35	16.2	0
15	16QAM	36	0	15.17	15.12	15.24		
15	16QAM	36	20	15.15	15.13	15.21		
15	16QAM	36	39	15.08	15.05	15.16	16.2	0
15	16QAM	75	0	15.13	15.08	15.18		
15	64QAM	1	0	15.39	15.32	15.41		
15	64QAM	1	37	15.25	15.22	15.29	16.2	0
15	64QAM	1	74	15.22	15.23	15.33		
15	64QAM	36	0	15.18	15.15	15.27		
15	64QAM	36	20	15.18	15.16	15.27	16.2	0
15	64QAM	36	39	15.12	15.08	15.24		
15	64QAM	75	0	15.13	15.08	15.21		



Channel				20800	21100	21400	Tune-up limit (dBm)	MPR (dB)
Frequency (MHz)				2505	2535	2565		
10	QPSK	1	0	15.11	15.03	15.16	16.2	0
10	QPSK	1	25	15.04	15.09	15.11		
10	QPSK	1	49	15.01	15.01	15.09		
10	QPSK	25	0	15.10	15.09	15.17	16.2	0
10	QPSK	25	12	15.11	15.05	15.18		
10	QPSK	25	25	15.07	15.02	15.14		
10	QPSK	50	0	15.07	15.05	15.18	16.2	0
10	16QAM	1	0	15.37	15.31	15.41		
10	16QAM	1	25	15.33	15.24	15.35		
10	16QAM	1	49	15.28	15.25	15.34	16.2	0
10	16QAM	25	0	15.13	15.09	15.18		
10	16QAM	25	12	15.15	15.06	15.20		
10	16QAM	25	25	15.10	15.03	15.17	16.2	0
10	16QAM	50	0	15.10	15.06	15.18		
10	64QAM	1	0	15.28	15.21	15.34		
10	64QAM	1	25	15.23	15.21	15.27	16.2	0
10	64QAM	1	49	15.18	15.20	15.26		
10	64QAM	25	0	15.14	15.10	15.23		
10	64QAM	25	12	15.15	15.12	15.22	16.2	0
10	64QAM	25	25	15.08	15.04	15.16		
10	64QAM	50	0	15.14	15.07	15.24		
Channel				20775	21100	21425	Tune-up limit (dBm)	MPR (dB)
Frequency (MHz)				2502.5	2535	2567.5		
5	QPSK	1	0	15.03	15.03	15.15	16.2	0
5	QPSK	1	12	15.03	15.01	15.11		
5	QPSK	1	24	15.09	15.01	15.09		
5	QPSK	12	0	15.11	15.06	15.15	16.2	0
5	QPSK	12	7	15.13	15.10	15.22		
5	QPSK	12	13	15.10	15.03	15.16		
5	QPSK	25	0	15.10	15.02	15.18	16.2	0
5	16QAM	1	0	15.32	15.30	15.37		
5	16QAM	1	12	15.34	15.27	15.39		
5	16QAM	1	24	15.28	15.27	15.34	16.2	0
5	16QAM	12	0	15.14	15.08	15.22		
5	16QAM	12	7	15.15	15.12	15.22		
5	16QAM	12	13	15.13	15.06	15.21	16.2	0
5	16QAM	25	0	15.10	15.05	15.18		
5	64QAM	1	0	15.24	15.23	15.33		
5	64QAM	1	12	15.23	15.18	15.30	16.2	0
5	64QAM	1	24	15.18	15.18	15.26		
5	64QAM	12	0	15.18	15.12	15.25		
5	64QAM	12	7	15.18	15.17	15.26	16.2	0
5	64QAM	12	13	15.18	15.11	15.26		
5	64QAM	25	0	15.12	15.05	15.21		



<LTE Band 13>

BW [MHz]	Modulation	RB Size	RB Offset	Power Low Ch. / Freq.	Power Middle Ch. / Freq.	Power High Ch. / Freq.	Tune-up limit (dBm)	MPR (dB)
Channel				23230				
Frequency (MHz)				782				
10	QPSK	1	0		21.14		22	0
10	QPSK	1	25		21.09			
10	QPSK	1	49		20.98			
10	QPSK	25	0		21.12		22	0
10	QPSK	25	12		21.05			
10	QPSK	25	25		21.10			
10	QPSK	50	0		21.14		22	0
10	16QAM	1	0		21.43			
10	16QAM	1	25		21.29			
10	16QAM	1	49		21.20		22	0
10	16QAM	25	0		21.13			
10	16QAM	25	12		21.11			
10	16QAM	25	25		21.06		22	0
10	16QAM	50	0		21.12			
10	64QAM	1	0		21.34			
10	64QAM	1	25		21.24		22	0
10	64QAM	1	49		21.15			
10	64QAM	25	0		20.17			
10	64QAM	25	12		20.15		22	0
10	64QAM	25	25		20.07			
10	64QAM	50	0		20.11			
Channel				23205	23230	23255	Tune-up limit (dBm)	MPR (dB)
Frequency (MHz)				779.5	782	784.5		
5	QPSK	1	0	21.15	21.10	21.07	22	0
5	QPSK	1	12	21.10	21.06	21.00		
5	QPSK	1	24	21.08	21.01	20.96		
5	QPSK	12	0	21.20	21.15	21.10	22	0
5	QPSK	12	7	21.17	21.14	21.13		
5	QPSK	12	13	21.14	21.09	21.05		
5	QPSK	25	0	21.15	21.12	21.09	22	0
5	16QAM	1	0	21.42	21.31	21.36		
5	16QAM	1	12	21.37	21.34	21.27		
5	16QAM	1	24	21.30	21.27	21.26	22	0
5	16QAM	12	0	21.20	21.16	21.08		
5	16QAM	12	7	21.13	21.13	21.09		
5	16QAM	12	13	21.14	21.10	21.05	22	0
5	16QAM	25	0	21.15	21.08	21.05		
5	64QAM	1	0	21.37	21.27	21.25		
5	64QAM	1	12	21.29	21.19	21.20	22	0
5	64QAM	1	24	21.24	21.17	21.15		
5	64QAM	12	0	20.19	20.15	20.12		
5	64QAM	12	7	20.20	20.15	20.14	22	0
5	64QAM	12	13	20.19	20.12	20.08		
5	64QAM	25	0	20.14	20.10	20.10		

**<Reduced Power Mode for Hotspot On >**

**<LTE Band 2>**

BW [MHz]	Modulation	RB Size	RB Offset	Power Low Ch. / Freq.	Power Middle Ch. / Freq.	Power High Ch. / Freq.	Tune-up limit (dBm)	MPR (dB)
Channel				18700	18900	19100		
Frequency (MHz)				1860	1880	1900		
20	QPSK	1	0	12.82	13.00	13.08	14	0
20	QPSK	1	49	12.42	12.64	12.99		
20	QPSK	1	99	12.64	12.81	13.03		
20	QPSK	50	0	12.62	12.83	13.17	14	0
20	QPSK	50	24	12.58	12.74	13.11		
20	QPSK	50	50	12.49	12.72	13.11		
20	QPSK	100	0	12.59	12.77	13.12	14	0
20	16QAM	1	0	13.10	13.28	13.29		
20	16QAM	1	49	12.68	12.92	13.30		
20	16QAM	1	99	13.00	13.05	13.36	14	0
20	16QAM	50	0	12.67	12.86	13.19		
20	16QAM	50	24	12.58	12.81	13.15		
20	16QAM	50	50	12.52	12.73	13.11	14	0
20	16QAM	100	0	12.61	12.77	13.13		
20	64QAM	1	0	12.99	13.21	13.31		
20	64QAM	1	49	12.62	12.84	13.21	14	0
20	64QAM	1	99	12.84	13.02	13.27		
20	64QAM	50	0	12.65	12.85	13.19		
20	64QAM	50	24	12.61	12.80	13.15	14	0
20	64QAM	50	50	12.54	12.75	13.10		
20	64QAM	100	0	12.58	12.78	13.15		
Channel				18675	18900	19125	Tune-up limit (dBm)	MPR (dB)
Frequency (MHz)				1857.5	1880	1902.5		
15	QPSK	1	0	12.63	12.81	13.15	14	0
15	QPSK	1	37	12.44	12.64	13.01		
15	QPSK	1	74	12.41	12.67	13.06		
15	QPSK	36	0	12.58	12.80	13.12	14	0
15	QPSK	36	20	12.53	12.74	13.11		
15	QPSK	36	39	12.51	12.70	13.09		
15	QPSK	75	0	12.55	12.77	13.09	14	0
15	16QAM	1	0	12.91	13.15	13.43		
15	16QAM	1	37	12.73	12.96	13.32		
15	16QAM	1	74	12.70	12.95	13.34	14	0
15	16QAM	36	0	12.60	12.80	13.15		
15	16QAM	36	20	12.59	12.79	13.12		
15	16QAM	36	39	12.54	12.74	13.12	14	0
15	16QAM	75	0	12.60	12.77	13.11		
15	64QAM	1	0	12.89	13.00	13.34		
15	64QAM	1	37	12.66	12.85	13.22	14	0
15	64QAM	1	74	12.63	12.87	13.27		
15	64QAM	36	0	12.61	12.84	13.16		
15	64QAM	36	20	12.58	12.81	13.13	14	0
15	64QAM	36	39	12.53	12.76	13.12		
15	64QAM	75	0	12.53	12.76	13.11		



Channel				18650	18900	19150	Tune-up limit (dBm)	MPR (dB)
Frequency (MHz)				1855	1880	1905		
10	QPSK	1	0	12.73	12.95	13.09	14	0
10	QPSK	1	25	12.44	12.62	13.00		
10	QPSK	1	49	12.63	12.85	13.03		
10	QPSK	25	0	12.54	12.75	13.14	14	0
10	QPSK	25	12	12.50	12.71	13.11		
10	QPSK	25	25	12.50	12.69	13.07		
10	QPSK	50	0	12.52	12.73	13.12	14	0
10	16QAM	1	0	13.04	13.28	13.41		
10	16QAM	1	25	12.71	12.95	13.34		
10	16QAM	1	49	12.92	13.16	13.33	14	0
10	16QAM	25	0	12.59	12.78	13.14		
10	16QAM	25	12	12.58	12.77	13.09		
10	16QAM	25	25	12.51	12.71	13.12	14	0
10	16QAM	50	0	12.55	12.76	13.11		
10	64QAM	1	0	12.93	13.17	13.31		
10	64QAM	1	25	12.60	12.82	13.22	14	0
10	64QAM	1	49	12.77	13.04	13.22		
10	64QAM	25	0	12.58	12.77	13.13		
10	64QAM	25	12	12.55	12.79	13.11	14	0
10	64QAM	25	25	12.52	12.75	13.10		
10	64QAM	50	0	12.55	12.74	13.10		
Channel				18625	18900	19175	Tune-up limit (dBm)	MPR (dB)
Frequency (MHz)				1852.5	1880	1907.5		
5	QPSK	1	0	12.50	12.70	13.09	14	0
5	QPSK	1	12	12.41	12.64	13.02		
5	QPSK	1	24	12.46	12.63	13.04		
5	QPSK	12	0	12.53	12.73	13.12	14	0
5	QPSK	12	7	12.51	12.71	13.13		
5	QPSK	12	13	12.49	12.72	13.09		
5	QPSK	25	0	12.48	12.70	13.09	14	0
5	16QAM	1	0	12.78	12.99	13.38		
5	16QAM	1	12	12.73	12.95	13.35		
5	16QAM	1	24	12.72	12.92	13.27	14	0
5	16QAM	12	0	12.55	12.77	13.12		
5	16QAM	12	7	12.56	12.73	13.13		
5	16QAM	12	13	12.50	12.75	13.13	14	0
5	16QAM	25	0	12.54	12.73	13.08		
5	64QAM	1	0	12.69	12.89	13.26		
5	64QAM	1	12	12.59	12.82	13.20	14	0
5	64QAM	1	24	12.59	12.84	13.19		
5	64QAM	12	0	12.57	12.79	13.14		
5	64QAM	12	7	12.57	12.76	13.16	14	0
5	64QAM	12	13	12.53	12.78	13.15		
5	64QAM	25	0	12.53	12.74	13.09		



Channel				18615	18900	19185	Tune-up limit (dBm)	MPR (dB)
Frequency (MHz)				1851.5	1880	1908.5		
3	QPSK	1	0	12.46	12.63	13.05	14	0
3	QPSK	1	8	12.53	12.70	13.11		
3	QPSK	1	14	12.40	12.59	13.03		
3	QPSK	8	0	12.48	12.66	13.05	14	0
3	QPSK	8	4	12.47	12.71	13.11		
3	QPSK	8	7	12.47	12.65	13.07		
3	QPSK	15	0	12.47	12.69	13.07	14	0
3	16QAM	1	0	12.71	12.94	13.35		
3	16QAM	1	8	12.80	13.04	13.46		
3	16QAM	1	14	12.64	12.91	13.32	14	0
3	16QAM	8	0	12.55	12.76	13.12		
3	16QAM	8	4	12.58	12.79	13.15		
3	16QAM	8	7	12.58	12.74	13.11	14	0
3	16QAM	15	0	12.53	12.71	13.09		
3	64QAM	1	0	12.61	12.85	13.19		
3	64QAM	1	8	12.69	12.93	13.31	14	0
3	64QAM	1	14	12.61	12.80	13.19		
3	64QAM	8	0	12.53	12.74	13.12		
3	64QAM	8	4	12.52	12.74	13.14	14	0
3	64QAM	8	7	12.50	12.74	13.10		
3	64QAM	15	0	12.50	12.71	13.08		
Channel				18607	18900	19193	Tune-up limit (dBm)	MPR (dB)
Frequency (MHz)				1850.7	1880	1909.3		
1.4	QPSK	1	0	12.36	12.59	12.97	14	0
1.4	QPSK	1	3	12.44	12.62	13.00		
1.4	QPSK	1	5	12.36	12.56	12.97		
1.4	QPSK	3	0	12.41	12.65	13.02	14	0
1.4	QPSK	3	1	12.47	12.70	13.04		
1.4	QPSK	3	3	12.44	12.63	13.05		
1.4	QPSK	6	0	12.42	12.62	12.99	14	0
1.4	16QAM	1	0	12.64	12.86	13.25	14	0
1.4	16QAM	1	3	12.68	12.92	13.29		
1.4	16QAM	1	5	12.64	12.84	13.23		
1.4	16QAM	3	0	12.47	12.65	13.03	14	0
1.4	16QAM	3	1	12.51	12.67	13.06		
1.4	16QAM	3	3	12.45	12.68	13.08		
1.4	16QAM	6	0	12.50	12.68	13.07	14	0
1.4	64QAM	1	0	12.52	12.75	13.12	14	0
1.4	64QAM	1	3	12.57	12.83	13.23		
1.4	64QAM	1	5	12.52	12.74	13.10		
1.4	64QAM	3	0	12.50	12.78	13.13	14	0
1.4	64QAM	3	1	12.58	12.84	13.15		
1.4	64QAM	3	3	12.56	12.77	13.17		
1.4	64QAM	6	0	12.42	12.63	13.01	14	0





<LTE Band 4>

BW [MHz]	Modulation	RB Size	RB Offset	Power Low Ch. / Freq.	Power Middle Ch. / Freq.	Power High Ch. / Freq.	Tune-up limit (dBm)	MPR (dB)
Channel				20050	20175	20300		
Frequency (MHz)				1720	1732.5	1745		
20	QPSK	1	0	14.40	14.50	14.46	15.3	0
20	QPSK	1	49	14.35	14.46	14.40		
20	QPSK	1	99	14.60	14.49	14.26		
20	QPSK	50	0	14.39	14.50	14.20	15.3	0
20	QPSK	50	24	14.24	14.32	14.19		
20	QPSK	50	50	14.30	14.25	14.41		
20	QPSK	100	0	14.28	14.33	14.40		
20	16QAM	1	0	14.68	14.73	14.72	15.3	0
20	16QAM	1	49	14.41	14.41	14.54		
20	16QAM	1	99	14.40	14.42	14.51		
20	16QAM	50	0	14.38	14.43	14.50	15.3	0
20	16QAM	50	24	14.24	14.31	14.39		
20	16QAM	50	50	14.25	14.22	14.39		
20	16QAM	100	0	14.29	14.31	14.38		
20	64QAM	1	0	14.64	14.72	14.62	15.3	0
20	64QAM	1	49	14.38	14.45	14.44		
20	64QAM	1	99	14.36	14.46	14.40		
20	64QAM	50	0	14.37	14.44	14.54	15.3	0
20	64QAM	50	24	14.31	14.36	14.41		
20	64QAM	50	50	14.33	14.27	14.43		
20	64QAM	100	0	14.30	14.37	14.41		
Channel				20025	20175	20325	Tune-up limit (dBm)	MPR (dB)
Frequency (MHz)				1717.5	1732.5	1747.5		
15	QPSK	1	0	14.36	14.40	14.48	15.3	0
15	QPSK	1	37	14.12	14.15	14.24		
15	QPSK	1	74	14.19	14.25	14.30		
15	QPSK	36	0	14.30	14.33	14.45	15.3	0
15	QPSK	36	20	14.24	14.31	14.33		
15	QPSK	36	39	14.26	14.23	14.39		
15	QPSK	75	0	14.22	14.31	14.34		
15	16QAM	1	0	14.66	14.65	14.70	15.3	0
15	16QAM	1	37	14.43	14.42	14.48		
15	16QAM	1	74	14.48	14.48	14.55		
15	16QAM	36	0	14.33	14.36	14.43	15.3	0
15	16QAM	36	20	14.27	14.31	14.39		
15	16QAM	36	39	14.30	14.23	14.36		
15	16QAM	75	0	14.25	14.29	14.33		
15	64QAM	1	0	14.56	14.62	14.69	15.3	0
15	64QAM	1	37	14.33	14.41	14.43		
15	64QAM	1	74	14.36	14.48	14.47		
15	64QAM	36	0	14.37	14.43	14.48	15.3	0
15	64QAM	36	20	14.29	14.35	14.44		
15	64QAM	36	39	14.30	14.26	14.46		
15	64QAM	75	0	14.25	14.33	14.38		



Channel				20000	20175	20350	Tune-up limit (dBm)	MPR (dB)
Frequency (MHz)				1715	1732.5	1750		
10	QPSK	1	0	14.17	14.30	14.40	15.3	0
10	QPSK	1	25	14.19	14.17	14.49		
10	QPSK	1	49	14.20	14.16	14.40		
10	QPSK	25	0	14.29	13.95	14.28	15.3	0
10	QPSK	25	12	14.27	14.30	14.44		
10	QPSK	25	25	14.21	14.37	14.39		
10	QPSK	50	0	14.24	14.29	14.43	15.3	0
10	16QAM	1	0	14.53	14.54	14.62		
10	16QAM	1	25	14.46	14.37	14.58		
10	16QAM	1	49	14.41	14.36	14.51	15.3	0
10	16QAM	25	0	14.28	14.32	14.36		
10	16QAM	25	12	14.27	14.29	14.43		
10	16QAM	25	25	14.24	14.27	14.38	15.3	0
10	16QAM	50	0	14.27	14.26	14.40		
10	64QAM	1	0	14.46	14.49	14.60		
10	64QAM	1	25	14.33	14.36	14.53	15.3	0
10	64QAM	1	49	14.33	14.31	14.51		
10	64QAM	25	0	14.32	14.34	14.43		
10	64QAM	25	12	14.29	14.34	14.47	15.3	0
10	64QAM	25	25	14.24	14.28	14.39		
10	64QAM	50	0	14.25	14.34	14.45		
Channel				19975	20175	20375	Tune-up limit (dBm)	MPR (dB)
Frequency (MHz)				1712.5	1732.5	1752.5		
5	QPSK	1	0	14.22	14.29	14.41	15.3	0
5	QPSK	1	12	14.15	14.12	14.19		
5	QPSK	1	24	14.15	14.17	14.28		
5	QPSK	12	0	13.95	14.30	14.18	15.3	0
5	QPSK	12	7	14.27	14.30	14.45		
5	QPSK	12	13	14.20	14.25	14.34		
5	QPSK	25	0	14.24	14.26	14.37	15.3	0
5	16QAM	1	0	14.53	14.47	14.64		
5	16QAM	1	12	14.44	14.41	14.55		
5	16QAM	1	24	14.39	14.39	14.56	15.3	0
5	16QAM	12	0	14.27	14.27	14.43		
5	16QAM	12	7	14.28	14.27	14.43		
5	16QAM	12	13	14.24	14.23	14.39	15.3	0
5	16QAM	25	0	14.26	14.25	14.36		
5	64QAM	1	0	14.45	14.45	14.60		
5	64QAM	1	12	14.36	14.39	14.51	15.3	0
5	64QAM	1	24	14.34	14.35	14.47		
5	64QAM	12	0	14.33	14.34	14.47		
5	64QAM	12	7	14.29	14.35	14.47	15.3	0
5	64QAM	12	13	14.27	14.34	14.42		
5	64QAM	25	0	14.24	14.25	14.44		



Channel				19965	20175	20385	Tune-up limit (dBm)	MPR (dB)
Frequency (MHz)				1711.5	1732.5	1753.5		
3	QPSK	1	0	14.57	14.22	14.33	15.3	0
3	QPSK	1	8	14.15	14.29	14.37		
3	QPSK	1	14	14.50	14.20	14.20		
3	QPSK	8	0	14.21	14.12	14.35	15.3	0
3	QPSK	8	4	14.25	14.25	14.30		
3	QPSK	8	7	14.19	14.48	14.28		
3	QPSK	15	0	14.19	14.26	14.40	15.3	0
3	16QAM	1	0	14.44	14.42	14.53		
3	16QAM	1	8	14.52	14.48	14.64		
3	16QAM	1	14	14.37	14.36	14.52	15.3	0
3	16QAM	8	0	14.31	14.31	14.43		
3	16QAM	8	4	14.30	14.30	14.44		
3	16QAM	8	7	14.29	14.27	14.42	15.3	0
3	16QAM	15	0	14.21	14.24	14.39		
3	64QAM	1	0	14.38	14.41	14.54		
3	64QAM	1	8	14.45	14.45	14.59	15.3	0
3	64QAM	1	14	14.34	14.36	14.50		
3	64QAM	8	0	14.29	14.32	14.43		
3	64QAM	8	4	14.27	14.32	14.46	15.3	0
3	64QAM	8	7	14.26	14.30	14.43		
3	64QAM	15	0	14.24	14.28	14.38		
Channel				19957	20175	20393	Tune-up limit (dBm)	MPR (dB)
Frequency (MHz)				1710.7	1732.5	1754.3		
1.4	QPSK	1	0	14.12	14.12	14.26	15.3	0
1.4	QPSK	1	3	14.14	14.18	14.32		
1.4	QPSK	1	5	14.07	14.12	14.25		
1.4	QPSK	3	0	14.15	14.20	14.27		
1.4	QPSK	3	1	14.20	14.23	14.34		
1.4	QPSK	3	3	14.20	14.21	14.33	15.3	0
1.4	QPSK	6	0	14.16	14.20	14.30		
1.4	16QAM	1	0	14.40	14.37	14.51	15.3	0
1.4	16QAM	1	3	14.50	14.45	14.56		
1.4	16QAM	1	5	14.37	14.32	14.48		
1.4	16QAM	3	0	14.17	14.16	14.32		
1.4	16QAM	3	1	14.22	14.19	14.37		
1.4	16QAM	3	3	14.22	14.17	14.35	15.3	0
1.4	16QAM	6	0	14.24	14.21	14.38		
1.4	64QAM	1	0	14.27	14.32	14.44	15.3	0
1.4	64QAM	1	3	14.37	14.34	14.51		
1.4	64QAM	1	5	14.32	14.28	14.46		
1.4	64QAM	3	0	14.31	14.32	14.41		
1.4	64QAM	3	1	14.33	14.36	14.46		
1.4	64QAM	3	3	14.35	14.32	14.47		
1.4	64QAM	6	0	14.16	14.20	14.31	15.3	0



<LTE Band 66>

BW [MHz]	Modulation	RB Size	RB Offset	Power Low Ch. / Freq.	Power Middle Ch. / Freq.	Power High Ch. / Freq.	Tune-up limit (dBm)	MPR (dB)
Channel				132072	132322	132572	15.3	0
Frequency (MHz)				1720	1745	1770		
20	QPSK	1	0	14.47	14.47	14.53	15.3	0
20	QPSK	1	49	14.15	14.25	14.19		
20	QPSK	1	99	14.17	14.13	14.06		
20	QPSK	50	0	14.40	14.46	14.48	15.3	0
20	QPSK	50	24	14.26	14.38	14.35		
20	QPSK	50	50	14.31	14.30	14.23		
20	QPSK	100	0	14.30	14.41	14.43		
20	16QAM	1	0	14.52	14.51	14.60	15.3	0
20	16QAM	1	49	14.21	14.33	14.27		
20	16QAM	1	99	14.22	14.23	14.16		
20	16QAM	50	0	14.22	14.33	14.29	15.3	0
20	16QAM	50	24	14.14	14.26	14.19		
20	16QAM	50	50	14.12	14.12	14.06		
20	16QAM	100	0	14.08	14.20	14.17		
20	64QAM	1	0	14.42	14.54	14.56	15.3	0
20	64QAM	1	49	14.14	14.33	14.24		
20	64QAM	1	99	14.13	14.19	14.09		
20	64QAM	50	0	14.24	14.34	14.29	15.3	0
20	64QAM	50	24	14.14	14.20	14.20		
20	64QAM	50	50	14.16	14.14	14.09		
20	64QAM	100	0	14.11	14.22	14.20		
Channel				132047	132322	132597	15.3	0
Frequency (MHz)				1717.5	1745	1772.5		
15	QPSK	1	0	14.20	14.28	14.27	15.3	0
15	QPSK	1	37	13.97	14.06	13.97		
15	QPSK	1	74	14.02	13.99	13.90		
15	QPSK	36	0	14.17	14.23	14.17	15.3	0
15	QPSK	36	20	14.07	14.19	14.12		
15	QPSK	36	39	13.98	14.11	14.04		
15	QPSK	75	0	14.07	14.15	14.12		
15	16QAM	1	0	14.50	14.58	14.53	15.3	0
15	16QAM	1	37	14.25	14.32	14.29		
15	16QAM	1	74	14.29	14.28	14.22		
15	16QAM	36	0	14.19	14.31	14.21	15.3	0
15	16QAM	36	20	14.12	14.21	14.16		
15	16QAM	36	39	14.03	14.13	14.05		
15	16QAM	75	0	14.11	14.22	14.15		
15	64QAM	1	0	14.44	14.51	14.43	15.3	0
15	64QAM	1	37	14.19	14.27	14.16		
15	64QAM	1	74	14.25	14.26	14.11		
15	64QAM	36	0	14.21	14.34	14.25	15.3	0
15	64QAM	36	20	14.15	14.23	14.15		
15	64QAM	36	39	14.08	14.17	14.08		
15	64QAM	75	0	14.12	14.23	14.14		



Channel				132022	132322	132622	Tune-up limit (dBm)	MPR (dB)
Frequency (MHz)				1715	1745	1775		
10	QPSK	1	0	14.14	14.21	14.14	15.3	0
10	QPSK	1	25	13.98	14.05	14.01		
10	QPSK	1	49	13.96	14.02	13.92		
10	QPSK	25	0	14.14	14.20	14.10	15.3	0
10	QPSK	25	12	14.07	14.12	14.08		
10	QPSK	25	25	14.01	14.10	14.03		
10	QPSK	50	0	14.08	14.13	14.07	15.3	0
10	16QAM	1	0	14.40	14.51	14.43		
10	16QAM	1	25	14.24	14.39	14.28		
10	16QAM	1	49	14.21	14.30	14.16	15.3	0
10	16QAM	25	0	14.13	14.23	14.14		
10	16QAM	25	12	14.13	14.21	14.14		
10	16QAM	25	25	14.03	14.15	14.06	15.3	0
10	16QAM	50	0	14.10	14.20	14.10		
10	64QAM	1	0	14.28	14.36	14.35		
10	64QAM	1	25	14.14	14.21	14.18	15.3	0
10	64QAM	1	49	14.09	14.17	14.12		
10	64QAM	25	0	14.16	14.27	14.17		
10	64QAM	25	12	14.13	14.22	14.12	15.3	0
10	64QAM	25	25	14.04	14.14	14.04		
10	64QAM	50	0	14.13	14.22	14.13		
Channel				131997	132322	132647	Tune-up limit (dBm)	MPR (dB)
Frequency (MHz)				1712.5	1745	1777.5		
5	QPSK	1	0	14.05	14.14	14.04	15.3	0
5	QPSK	1	12	14.00	14.06	13.97		
5	QPSK	1	24	13.96	14.03	13.93		
5	QPSK	12	0	14.11	14.17	14.03	15.3	0
5	QPSK	12	7	14.06	14.15	14.04		
5	QPSK	12	13	14.05	14.10	14.02		
5	QPSK	25	0	14.07	14.09	14.02	15.3	0
5	16QAM	1	0	14.31	14.36	14.31		
5	16QAM	1	12	14.25	14.32	14.25		
5	16QAM	1	24	14.20	14.30	14.18	15.3	0
5	16QAM	12	0	14.13	14.17	14.08		
5	16QAM	12	7	14.09	14.17	14.04		
5	16QAM	12	13	14.07	14.16	14.02	15.3	0
5	16QAM	25	0	14.09	14.18	14.04		
5	64QAM	1	0	14.24	14.33	14.22		
5	64QAM	1	12	14.15	14.23	14.15	15.3	0
5	64QAM	1	24	14.15	14.24	14.13		
5	64QAM	12	0	14.15	14.22	14.13		
5	64QAM	12	7	14.13	14.23	14.10	15.3	0
5	64QAM	12	13	14.11	14.20	14.06		
5	64QAM	25	0	14.09	14.17	14.06		



Channel				131987	132322	132657	Tune-up limit (dBm)	MPR (dB)
Frequency (MHz)				1711.5	1745	1778.5		
3	QPSK	1	0	14.03	14.09	13.98	15.3	0
3	QPSK	1	8	14.09	14.16	14.06		
3	QPSK	1	14	13.96	14.00	13.92		
3	QPSK	8	0	14.06	14.11	13.99	15.3	0
3	QPSK	8	4	14.04	14.15	14.06		
3	QPSK	8	7	14.03	14.11	13.98		
3	QPSK	15	0	14.01	14.12	14.01	15.3	0
3	16QAM	1	0	14.31	14.34	14.26		
3	16QAM	1	8	14.39	14.43	14.31		
3	16QAM	1	14	14.23	14.28	14.18	15.3	0
3	16QAM	8	0	14.11	14.20	14.10		
3	16QAM	8	4	14.12	14.20	14.12		
3	16QAM	8	7	14.07	14.16	14.07	15.3	0
3	16QAM	15	0	14.10	14.14	14.07		
3	64QAM	1	0	14.17	14.26	14.21		
3	64QAM	1	8	14.23	14.33	14.25	15.3	0
3	64QAM	1	14	14.12	14.21	14.15		
3	64QAM	8	0	14.10	14.19	14.11		
3	64QAM	8	4	14.10	14.19	14.08	15.3	0
3	64QAM	8	7	14.07	14.15	14.06		
3	64QAM	15	0	14.08	14.13	14.06		
Channel				131979	132322	132665	Tune-up limit (dBm)	MPR (dB)
Frequency (MHz)				1710.7	1745	1779.3		
1.4	QPSK	1	0	13.95	13.97	13.88	15.3	0
1.4	QPSK	1	3	13.96	14.02	13.94		
1.4	QPSK	1	5	13.91	13.94	13.85		
1.4	QPSK	3	0	13.97	14.00	13.92	15.3	0
1.4	QPSK	3	1	14.03	14.10	13.94		
1.4	QPSK	3	3	14.02	14.03	13.95		
1.4	QPSK	6	0	13.99	14.04	13.95	15.3	0
1.4	16QAM	1	0	14.18	14.25	14.18	15.3	0
1.4	16QAM	1	3	14.27	14.33	14.20		
1.4	16QAM	1	5	14.13	14.21	14.13		
1.4	16QAM	3	0	13.97	14.06	13.98	15.3	0
1.4	16QAM	3	1	14.02	14.09	14.02		
1.4	16QAM	3	3	14.01	14.09	13.99		
1.4	16QAM	6	0	14.04	14.13	14.00	15.3	0
1.4	64QAM	1	0	14.10	14.19	14.10	15.3	0
1.4	64QAM	1	3	14.21	14.22	14.14		
1.4	64QAM	1	5	14.11	14.17	14.10		
1.4	64QAM	3	0	14.08	14.20	14.07	15.3	0
1.4	64QAM	3	1	14.13	14.24	14.12		
1.4	64QAM	3	3	14.14	14.23	14.10		
1.4	64QAM	6	0	13.97	14.06	13.96	15.3	0



**<Reduced Power Mode for P-Sensor On>**

**<LTE Band 2>**

BW [MHz]	Modulation	RB Size	RB Offset	Power Low Ch. / Freq.	Power Middle Ch. / Freq.	Power High Ch. / Freq.	Tune-up limit (dBm)	MPR (dB)
Channel				18700	18900	19100	16.5	0
Frequency (MHz)				1860	1880	1900		
20	QPSK	1	0	15.55	15.62	15.78	16.5	0
20	QPSK	1	49	15.40	15.48	15.67		
20	QPSK	1	99	15.48	15.57	15.66		
20	QPSK	50	0	15.47	15.66	15.86	16.5	0
20	QPSK	50	24	15.44	15.58	15.81		
20	QPSK	50	50	15.43	15.53	15.77		
20	QPSK	100	0	15.42	15.59	15.81	16.5	0
20	16QAM	1	0	15.99	15.89	15.99		
20	16QAM	1	49	15.70	15.87	16.09		
20	16QAM	1	99	15.79	15.93	16.06	16.5	0
20	16QAM	50	0	15.53	15.68	15.92		
20	16QAM	50	24	15.51	15.59	15.83		
20	16QAM	50	50	15.42	15.54	15.73	16.5	0
20	16QAM	100	0	15.42	15.58	15.81		
20	64QAM	1	0	15.85	15.96	16.02		
20	64QAM	1	49	15.50	15.64	15.90	16.5	0
20	64QAM	1	99	15.64	15.71	15.84		
20	64QAM	50	0	15.47	15.60	15.90		
20	64QAM	50	24	15.48	15.62	15.79	16.5	0
20	64QAM	50	50	15.42	15.65	15.50		
20	64QAM	100	0	15.41	15.57	15.55		
Channel				18675	18900	19125	16.5	0
Frequency (MHz)				1857.5	1880	1902.5		
15	QPSK	1	0	15.52	15.73	15.91	16.5	0
15	QPSK	1	37	15.26	15.49	15.73		
15	QPSK	1	74	15.33	15.47	15.71		
15	QPSK	36	0	15.43	15.62	15.84	16.5	0
15	QPSK	36	20	15.38	15.55	15.80		
15	QPSK	36	39	15.40	15.49	15.73		
15	QPSK	75	0	15.38	15.56	15.78	16.5	0
15	16QAM	1	0	15.88	16.04	16.11		
15	16QAM	1	37	15.63	15.88	16.06		
15	16QAM	1	74	15.68	15.78	16.05	16.5	0
15	16QAM	36	0	15.46	15.64	15.83		
15	16QAM	36	20	15.43	15.61	15.77		
15	16QAM	36	39	15.41	15.51	15.70	16.5	0
15	16QAM	75	0	15.39	15.58	15.81		
15	64QAM	1	0	15.72	15.89	16.05		
15	64QAM	1	37	15.47	15.70	15.85	16.5	0
15	64QAM	1	74	15.56	15.60	15.85		
15	64QAM	36	0	15.45	15.62	15.84		
15	64QAM	36	20	15.42	15.56	15.77	16.5	0
15	64QAM	36	39	15.40	15.51	15.67		
15	64QAM	75	0	15.36	15.58	15.79		



Channel				18650	18900	19150	Tune-up limit (dBm)	MPR (dB)
Frequency (MHz)				1855	1880	1905		
10	QPSK	1	0	15.64	15.77	15.80	16.5	0
10	QPSK	1	25	15.31	15.48	15.71		
10	QPSK	1	49	15.58	15.64	15.66		
10	QPSK	25	0	15.39	15.56	15.79	16.5	0
10	QPSK	25	12	15.34	15.54	15.74		
10	QPSK	25	25	15.32	15.51	15.71		
10	QPSK	50	0	15.36	15.54	15.76	16.5	0
10	16QAM	1	0	15.96	16.01	16.01		
10	16QAM	1	25	15.56	15.83	16.03		
10	16QAM	1	49	15.84	15.99	15.97	16.5	0
10	16QAM	25	0	15.41	15.56	15.76		
10	16QAM	25	12	15.37	15.55	15.73		
10	16QAM	25	25	15.35	15.51	15.70	16.5	0
10	16QAM	50	0	15.40	15.58	15.78		
10	64QAM	1	0	15.77	15.92	15.90		
10	64QAM	1	25	15.44	15.65	15.79	16.5	0
10	64QAM	1	49	15.65	15.77	15.76		
10	64QAM	25	0	15.43	15.60	15.79		
10	64QAM	25	12	15.38	15.55	15.75	16.5	0
10	64QAM	25	25	15.33	15.52	15.70		
10	64QAM	50	0	15.39	15.55	15.75		
Channel				18625	18900	19175	Tune-up limit (dBm)	MPR (dB)
Frequency (MHz)				1852.5	1880	1907.5		
5	QPSK	1	0	15.35	15.54	15.70	16.5	0
5	QPSK	1	12	15.28	15.42	15.62		
5	QPSK	1	24	15.28	15.43	15.64		
5	QPSK	12	0	15.35	15.53	15.74	16.5	0
5	QPSK	12	7	15.36	15.50	15.73		
5	QPSK	12	13	15.32	15.47	15.72		
5	QPSK	25	0	15.33	15.49	15.70	16.5	0
5	16QAM	1	0	15.75	15.93	15.89		
5	16QAM	1	12	15.65	15.87	16.02		
5	16QAM	1	24	15.61	15.86	16.08	16.5	0
5	16QAM	12	0	15.40	15.55	15.74		
5	16QAM	12	7	15.37	15.55	15.79		
5	16QAM	12	13	15.34	15.53	15.74	16.5	0
5	16QAM	25	0	15.35	15.49	15.74		
5	64QAM	1	0	15.51	15.67	15.90		
5	64QAM	1	12	15.46	15.57	15.86	16.5	0
5	64QAM	1	24	15.43	15.58	15.81		
5	64QAM	12	0	15.35	15.53	15.72		
5	64QAM	12	7	15.35	15.54	15.75	16.5	0
5	64QAM	12	13	15.35	15.51	15.73		
5	64QAM	25	0	15.35	15.50	15.73		





Channel				18615	18900	19185	Tune-up limit (dBm)	MPR (dB)
Frequency (MHz)				1851.5	1880	1908.5		
3	QPSK	1	0	15.29	15.45	15.66	16.5	0
3	QPSK	1	8	15.25	15.45	15.62		
3	QPSK	1	14	15.27	15.42	15.64		
3	QPSK	8	0	15.30	15.49	15.66	16.5	0
3	QPSK	8	4	15.35	15.48	15.71		
3	QPSK	8	7	15.31	15.44	15.66		
3	QPSK	15	0	15.32	15.49	15.69	16.5	0
3	16QAM	1	0	15.64	15.93	16.01		
3	16QAM	1	8	15.67	15.88	16.07		
3	16QAM	1	14	15.61	15.82	16.03	16.5	0
3	16QAM	8	0	15.39	15.59	15.80		
3	16QAM	8	4	15.42	15.61	15.76		
3	16QAM	8	7	15.39	15.55	15.75	16.5	0
3	16QAM	15	0	15.36	15.50	15.72		
3	64QAM	1	0	15.44	15.63	15.86		
3	64QAM	1	8	15.40	15.61	15.82	16.5	0
3	64QAM	1	14	15.38	15.57	15.78		
3	64QAM	8	0	15.35	15.49	15.73		
3	64QAM	8	4	15.38	15.54	15.74	16.5	0
3	64QAM	8	7	15.31	15.49	15.70		
3	64QAM	15	0	15.33	15.52	15.71		
Channel				18607	18900	19193	Tune-up limit (dBm)	MPR (dB)
Frequency (MHz)				1850.7	1880	1909.3		
1.4	QPSK	1	0	15.21	15.42	15.62	16.5	0
1.4	QPSK	1	3	15.30	15.48	15.65		
1.4	QPSK	1	5	15.25	15.36	15.60		
1.4	QPSK	3	0	15.29	15.41	15.65		
1.4	QPSK	3	1	15.30	15.49	15.68		
1.4	QPSK	3	3	15.29	15.42	15.61	16.5	0
1.4	QPSK	6	0	15.28	15.42	15.62		
1.4	16QAM	1	0	15.54	15.80	16.02	16.5	0
1.4	16QAM	1	3	15.62	15.90	16.05		
1.4	16QAM	1	5	15.57	15.80	16.00		
1.4	16QAM	3	0	15.31	15.49	15.71		
1.4	16QAM	3	1	15.36	15.50	15.70		
1.4	16QAM	3	3	15.32	15.45	15.64	16.5	0
1.4	16QAM	6	0	15.34	15.44	15.67		
1.4	64QAM	1	0	15.40	15.60	15.80	16.5	0
1.4	64QAM	1	3	15.51	15.59	15.84		
1.4	64QAM	1	5	15.38	15.52	15.73		
1.4	64QAM	3	0	15.31	15.42	15.63		
1.4	64QAM	3	1	15.34	15.51	15.68		
1.4	64QAM	3	3	15.24	15.41	15.59		
1.4	64QAM	6	0	15.27	15.41	15.62	16.5	0



<LTE Band 4>

BW [MHz]	Modulation	RB Size	RB Offset	Power Low Ch. / Freq.	Power Middle Ch. / Freq.	Power High Ch. / Freq.	Tune-up limit (dBm)	MPR (dB)
Channel				20050	20175	20300		
Frequency (MHz)				1720	1732.5	1745		
20	QPSK	1	0	15.49	15.44	15.47	16	0
20	QPSK	1	49	15.25	15.25	15.32		
20	QPSK	1	99	15.24	15.19	15.24		
20	QPSK	50	0	15.44	15.43	15.42	16	0
20	QPSK	50	24	15.36	15.36	15.46		
20	QPSK	50	50	15.34	15.32	15.37		
20	QPSK	100	0	15.38	15.35	15.42	16	0
20	16QAM	1	0	15.85	15.79	15.76		
20	16QAM	1	49	15.61	15.54	15.63		
20	16QAM	1	99	15.51	15.52	15.58	16	0
20	16QAM	50	0	15.50	15.47	15.50		
20	16QAM	50	24	15.42	15.39	15.45		
20	16QAM	50	50	15.36	15.34	15.40	16	0
20	16QAM	100	0	15.40	15.38	15.47		
20	64QAM	1	0	15.72	15.66	15.65		
20	64QAM	1	49	15.47	15.42	15.51	16	0
20	64QAM	1	99	15.43	15.38	15.45		
20	64QAM	50	0	15.45	15.46	15.49		
20	64QAM	50	24	15.43	15.39	15.46	16	0
20	64QAM	50	50	15.33	15.34	15.42		
20	64QAM	100	0	15.44	15.39	15.47		
Channel				20025	20175	20325	Tune-up limit (dBm)	MPR (dB)
Frequency (MHz)				1717.5	1732.5	1747.5		
15	QPSK	1	0	15.43	15.43	15.44	16	0
15	QPSK	1	37	15.25	15.22	15.31		
15	QPSK	1	74	15.27	15.24	15.32		
15	QPSK	36	0	15.42	15.38	15.47	16	0
15	QPSK	36	20	15.34	15.32	15.42		
15	QPSK	36	39	15.30	15.31	15.39		
15	QPSK	75	0	15.33	15.37	15.39	16	0
15	16QAM	1	0	15.80	15.77	15.73		
15	16QAM	1	37	15.59	15.55	15.65		
15	16QAM	1	74	15.59	15.55	15.62	16	0
15	16QAM	36	0	15.45	15.43	15.54		
15	16QAM	36	20	15.41	15.36	15.47		
15	16QAM	36	39	15.36	15.33	15.38	16	0
15	16QAM	75	0	15.42	15.42	15.45		
15	64QAM	1	0	15.61	15.62	15.66		
15	64QAM	1	37	15.43	15.42	15.53	16	0
15	64QAM	1	74	15.46	15.41	15.51		
15	64QAM	36	0	15.43	15.41	15.52		
15	64QAM	36	20	15.40	15.35	15.47	16	0
15	64QAM	36	39	15.33	15.34	15.35		
15	64QAM	75	0	15.42	15.37	15.44		



Channel				20000	20175	20350	Tune-up limit (dBm)	MPR (dB)
Frequency (MHz)				1715	1732.5	1750		
10	QPSK	1	0	15.37	15.35	15.45	16	0
10	QPSK	1	25	15.29	15.25	15.30		
10	QPSK	1	49	15.22	15.20	15.26		
10	QPSK	25	0	15.40	15.37	15.43	16	0
10	QPSK	25	12	15.31	15.30	15.36		
10	QPSK	25	25	15.32	15.27	15.35		
10	QPSK	50	0	15.33	15.31	15.38	16	0
10	16QAM	1	0	15.73	15.66	15.75		
10	16QAM	1	25	15.60	15.53	15.63		
10	16QAM	1	49	15.56	15.53	15.59	16	0
10	16QAM	25	0	15.42	15.37	15.44		
10	16QAM	25	12	15.41	15.34	15.42		
10	16QAM	25	25	15.35	15.31	15.36	16	0
10	16QAM	50	0	15.37	15.38	15.45		
10	64QAM	1	0	15.60	15.56	15.62		
10	64QAM	1	25	15.50	15.47	15.51	16	0
10	64QAM	1	49	15.44	15.43	15.45		
10	64QAM	25	0	15.39	15.36	15.44		
10	64QAM	25	12	15.41	15.36	15.41	16	0
10	64QAM	25	25	15.33	15.30	15.35		
10	64QAM	50	0	15.35	15.35	15.43		
Channel				19975	20175	20375	Tune-up limit (dBm)	MPR (dB)
Frequency (MHz)				1712.5	1732.5	1752.5		
5	QPSK	1	0	15.33	15.32	15.40	16	0
5	QPSK	1	12	15.27	15.24	15.30		
5	QPSK	1	24	15.31	15.25	15.31		
5	QPSK	12	0	15.37	15.35	15.39	16	0
5	QPSK	12	7	15.39	15.34	15.38		
5	QPSK	12	13	15.32	15.29	15.36		
5	QPSK	25	0	15.32	15.31	15.39	16	0
5	16QAM	1	0	15.65	15.58	15.73		
5	16QAM	1	12	15.60	15.53	15.66		
5	16QAM	1	24	15.59	15.50	15.65	16	0
5	16QAM	12	0	15.41	15.36	15.44		
5	16QAM	12	7	15.41	15.39	15.44		
5	16QAM	12	13	15.39	15.35	15.43	16	0
5	16QAM	25	0	15.39	15.38	15.40		
5	64QAM	1	0	15.55	15.52	15.55		
5	64QAM	1	12	15.47	15.45	15.47	16	0
5	64QAM	1	24	15.46	15.45	15.48		
5	64QAM	12	0	15.38	15.34	15.41		
5	64QAM	12	7	15.40	15.38	15.42	16	0
5	64QAM	12	13	15.39	15.34	15.41		
5	64QAM	25	0	15.37	15.33	15.37		



Channel				19965	20175	20385	Tune-up limit (dBm)	MPR (dB)
Frequency (MHz)				1711.5	1732.5	1753.5		
3	QPSK	1	0	15.28	15.25	15.34	16	0
3	QPSK	1	8	15.27	15.24	15.28		
3	QPSK	1	14	15.26	15.23	15.29		
3	QPSK	8	0	15.34	15.28	15.36	16	0
3	QPSK	8	4	15.33	15.33	15.38		
3	QPSK	8	7	15.32	15.30	15.33		
3	QPSK	15	0	15.29	15.29	15.38		
3	16QAM	1	0	15.61	15.51	15.66	16	0
3	16QAM	1	8	15.61	15.51	15.60		
3	16QAM	1	14	15.53	15.49	15.58		
3	16QAM	8	0	15.44	15.37	15.46	16	0
3	16QAM	8	4	15.41	15.43	15.46		
3	16QAM	8	7	15.40	15.39	15.44		
3	16QAM	15	0	15.35	15.36	15.38		
3	64QAM	1	0	15.48	15.48	15.49	16	0
3	64QAM	1	8	15.50	15.45	15.48		
3	64QAM	1	14	15.50	15.45	15.45		
3	64QAM	8	0	15.37	15.33	15.43	16	0
3	64QAM	8	4	15.37	15.38	15.40		
3	64QAM	8	7	15.35	15.35	15.40		
3	64QAM	15	0	15.35	15.34	15.39		
Channel				19957	20175	20393	Tune-up limit (dBm)	MPR (dB)
Frequency (MHz)				1710.7	1732.5	1754.3		
1.4	QPSK	1	0	15.19	15.17	15.26	16	0
1.4	QPSK	1	3	15.30	15.24	15.33		
1.4	QPSK	1	5	15.22	15.16	15.20		
1.4	QPSK	3	0	15.24	15.19	15.29		
1.4	QPSK	3	1	15.28	15.23	15.35		
1.4	QPSK	3	3	15.25	15.22	15.30		
1.4	QPSK	6	0	15.23	15.23	15.31	16	0
1.4	16QAM	1	0	15.51	15.44	15.54	16	0
1.4	16QAM	1	3	15.58	15.50	15.61		
1.4	16QAM	1	5	15.50	15.41	15.53		
1.4	16QAM	3	0	15.31	15.27	15.32		
1.4	16QAM	3	1	15.36	15.29	15.39		
1.4	16QAM	3	3	15.26	15.23	15.31		
1.4	16QAM	6	0	15.34	15.30	15.41	16	0
1.4	64QAM	1	0	15.43	15.34	15.41	16	0
1.4	64QAM	1	3	15.54	15.41	15.51		
1.4	64QAM	1	5	15.42	15.32	15.46		
1.4	64QAM	3	0	15.31	15.27	15.36		
1.4	64QAM	3	1	15.38	15.32	15.41		
1.4	64QAM	3	3	15.31	15.29	15.35		
1.4	64QAM	6	0	15.26	15.23	15.32	16	0



<LTE Band 66>

BW [MHz]	Modulation	RB Size	RB Offset	Power Low Ch. / Freq.	Power Middle Ch. / Freq.	Power High Ch. / Freq.	Tune-up limit (dBm)	MPR (dB)
Channel				132072	132322	132572		
Frequency (MHz)				1720	1745	1770		
20	QPSK	1	0	15.79	15.74	15.71	16	0
20	QPSK	1	49	15.35	15.31	15.31		
20	QPSK	1	99	15.31	15.35	15.29		
20	QPSK	50	0	15.78	15.70	15.65	16	0
20	QPSK	50	24	15.50	15.42	15.41		
20	QPSK	50	50	15.40	15.39	15.31		
20	QPSK	100	0	15.63	15.45	15.39	16	0
20	16QAM	1	0	15.93	15.86	15.84		
20	16QAM	1	49	15.63	15.64	15.59		
20	16QAM	1	99	15.63	15.56	15.52	16	0
20	16QAM	50	0	15.60	15.58	15.50		
20	16QAM	50	24	15.50	15.46	15.45		
20	16QAM	50	50	15.49	15.42	15.32	16	0
20	16QAM	100	0	15.51	15.47	15.41		
20	64QAM	1	0	15.78	15.76	15.76		
20	64QAM	1	49	15.55	15.51	15.47	16	0
20	64QAM	1	99	15.55	15.50	15.38		
20	64QAM	50	0	15.58	15.58	15.47		
20	64QAM	50	24	15.49	15.51	15.43	16	0
20	64QAM	50	50	15.46	15.40	15.33		
20	64QAM	100	0	15.51	15.46	15.43		
Channel				132047	132322	132597	Tune-up limit (dBm)	MPR (dB)
Frequency (MHz)				1717.5	1745	1772.5		
15	QPSK	1	0	15.61	15.51	15.48	16	0
15	QPSK	1	37	15.39	15.30	15.26		
15	QPSK	1	74	15.36	15.34	15.20		
15	QPSK	36	0	15.50	15.49	15.43	16	0
15	QPSK	36	20	15.48	15.44	15.34		
15	QPSK	36	39	15.43	15.39	15.28		
15	QPSK	75	0	15.47	15.42	15.41	16	0
15	16QAM	1	0	15.90	15.84	15.80		
15	16QAM	1	37	15.72	15.68	15.50		
15	16QAM	1	74	15.69	15.65	15.54	16	0
15	16QAM	36	0	15.56	15.53	15.50		
15	16QAM	36	20	15.48	15.48	15.38		
15	16QAM	36	39	15.42	15.43	15.30	16	0
15	16QAM	75	0	15.50	15.45	15.40		
15	64QAM	1	0	15.78	15.72	15.72		
15	64QAM	1	37	15.59	15.54	15.46	16	0
15	64QAM	1	74	15.56	15.53	15.41		
15	64QAM	36	0	15.55	15.50	15.48		
15	64QAM	36	20	15.47	15.46	15.41	16	0
15	64QAM	36	39	15.41	15.40	15.32		
15	64QAM	75	0	15.50	15.45	15.39		



Channel				132022	132322	132622	Tune-up limit (dBm)	MPR (dB)
Frequency (MHz)				1715	1745	1775		
10	QPSK	1	0	15.45	15.43	15.34	16	0
10	QPSK	1	25	15.13	15.32	15.16		
10	QPSK	1	49	15.33	15.27	15.13		
10	QPSK	25	0	15.46	15.45	15.32	16	0
10	QPSK	25	12	15.41	15.42	15.31		
10	QPSK	25	25	15.41	15.35	15.24		
10	QPSK	50	0	15.42	15.42	15.29	16	0
10	16QAM	1	0	15.85	15.73	15.61		
10	16QAM	1	25	15.70	15.62	15.49		
10	16QAM	1	49	15.68	15.57	15.41	16	0
10	16QAM	25	0	15.52	15.49	15.37		
10	16QAM	25	12	15.48	15.46	15.37		
10	16QAM	25	25	15.45	15.38	15.31	16	0
10	16QAM	50	0	15.49	15.47	15.36		
10	64QAM	1	0	15.65	15.62	15.58		
10	64QAM	1	25	15.50	15.51	15.39	16	0
10	64QAM	1	49	15.47	15.42	15.34		
10	64QAM	25	0	15.49	15.46	15.37		
10	64QAM	25	12	15.50	15.44	15.35	16	0
10	64QAM	25	25	15.43	15.42	15.32		
10	64QAM	50	0	15.49	15.46	15.34		
Channel				131997	132322	132647	Tune-up limit (dBm)	MPR (dB)
Frequency (MHz)				1712.5	1745	1777.5		
5	QPSK	1	0	15.43	15.38	15.28	16	0
5	QPSK	1	12	15.38	15.33	15.22		
5	QPSK	1	24	15.36	15.31	15.21		
5	QPSK	12	0	15.44	15.40	15.31	16	0
5	QPSK	12	7	15.43	15.40	15.32		
5	QPSK	12	13	15.42	15.39	15.25		
5	QPSK	25	0	15.45	15.38	15.28	16	0
5	16QAM	1	0	15.79	15.72	15.61		
5	16QAM	1	12	15.74	15.69	15.55		
5	16QAM	1	24	15.73	15.67	15.53	16	0
5	16QAM	12	0	15.52	15.47	15.34		
5	16QAM	12	7	15.53	15.48	15.31		
5	16QAM	12	13	15.46	15.42	15.30	16	0
5	16QAM	25	0	15.45	15.43	15.30		
5	64QAM	1	0	15.62	15.60	15.52		
5	64QAM	1	12	15.60	15.51	15.40	16	0
5	64QAM	1	24	15.58	15.49	15.42		
5	64QAM	12	0	15.48	15.43	15.32		
5	64QAM	12	7	15.51	15.44	15.34	16	0
5	64QAM	12	13	15.46	15.39	15.32		
5	64QAM	25	0	15.44	15.40	15.29		



Channel				131987	132322	132657	Tune-up limit (dBm)	MPR (dB)
Frequency (MHz)				1711.5	1745	1778.5		
3	QPSK	1	0	15.28	15.23	15.17	16	0
3	QPSK	1	8	15.27	15.24	15.09		
3	QPSK	1	14	15.25	15.22	15.16		
3	QPSK	8	0	15.33	15.31	15.22	16	0
3	QPSK	8	4	15.39	15.30	15.18		
3	QPSK	8	7	15.30	15.27	15.15		
3	QPSK	15	0	15.35	15.27	15.20	16	0
3	16QAM	1	0	15.63	15.61	15.46		
3	16QAM	1	8	15.58	15.57	15.47		
3	16QAM	1	14	15.58	15.50	15.43	16	0
3	16QAM	8	0	15.42	15.40	15.27		
3	16QAM	8	4	15.43	15.42	15.31		
3	16QAM	8	7	15.42	15.34	15.25	16	0
3	16QAM	15	0	15.37	15.34	15.24		
3	64QAM	1	0	15.48	15.45	15.31		
3	64QAM	1	8	15.44	15.39	15.30	16	0
3	64QAM	1	14	15.45	15.42	15.28		
3	64QAM	8	0	15.39	15.35	15.20		
3	64QAM	8	4	15.39	15.35	15.25	16	0
3	64QAM	8	7	15.36	15.32	15.21		
3	64QAM	15	0	15.35	15.29	15.21		
Channel				131979	132322	132665	Tune-up limit (dBm)	MPR (dB)
Frequency (MHz)				1710.7	1745	1779.3		
1.4	QPSK	1	0	15.26	15.21	15.11	16	0
1.4	QPSK	1	3	15.32	15.26	15.19		
1.4	QPSK	1	5	15.22	15.20	15.09		
1.4	QPSK	3	0	15.31	15.22	15.13	16	0
1.4	QPSK	3	1	15.35	15.30	15.20		
1.4	QPSK	3	3	15.27	15.25	15.14		
1.4	QPSK	6	0	15.30	15.27	15.16	16	0
1.4	16QAM	1	0	15.59	15.48	15.42	16	0
1.4	16QAM	1	3	15.68	15.55	15.49		
1.4	16QAM	1	5	15.54	15.49	15.36		
1.4	16QAM	3	0	15.36	15.27	15.23	16	0
1.4	16QAM	3	1	15.39	15.34	15.22		
1.4	16QAM	3	3	15.34	15.30	15.17		
1.4	16QAM	6	0	15.39	15.34	15.25	16	0
1.4	64QAM	1	0	15.49	15.38	15.33	16	0
1.4	64QAM	1	3	15.54	15.49	15.36		
1.4	64QAM	1	5	15.47	15.40	15.30		
1.4	64QAM	3	0	15.39	15.29	15.22	16	0
1.4	64QAM	3	1	15.41	15.37	15.27		
1.4	64QAM	3	3	15.37	15.30	15.20		
1.4	64QAM	6	0	15.31	15.27	15.17	16	0



**<Reduced Power Mode for Handheld On>**

**<LTE Band 2>**

BW [MHz]	Modulation	RB Size	RB Offset	Power Low Ch. / Freq.	Power Middle Ch. / Freq.	Power High Ch. / Freq.	Tune-up limit (dBm)	MPR (dB)
Channel				18700	18900	19100	20.6	0
Frequency (MHz)				1860	1880	1900		
20	QPSK	1	0	19.49	19.62	19.74	20.6	0
20	QPSK	1	49	19.13	19.31	19.66		
20	QPSK	1	99	19.35	19.46	19.68		
20	QPSK	50	0	19.30	19.48	19.80	20.6	0
20	QPSK	50	24	19.24	19.42	19.76		
20	QPSK	50	50	19.18	19.37	19.75		
20	QPSK	100	0	19.23	19.46	19.77	20.6	0
20	16QAM	1	0	19.85	19.96	20.05		
20	16QAM	1	49	19.47	19.64	20.00		
20	16QAM	1	99	19.68	19.81	20.02	20.6	0
20	16QAM	50	0	19.36	19.52	19.84		
20	16QAM	50	24	19.26	19.41	19.80		
20	16QAM	50	50	19.20	19.39	19.74	20.6	0
20	16QAM	100	0	19.23	19.42	19.76		
20	64QAM	1	0	19.78	19.91	19.95		
20	64QAM	1	49	19.34	19.53	19.89	20.6	0
20	64QAM	1	99	19.55	19.73	19.87		
20	64QAM	50	0	19.35	19.53	19.87		
20	64QAM	50	24	19.26	19.46	19.82	20.6	0
20	64QAM	50	50	19.21	19.43	19.80		
20	64QAM	100	0	19.30	19.48	19.81		
Channel				18675	18900	19125	20.6	0
Frequency (MHz)				1857.5	1880	1902.5		
15	QPSK	1	0	19.35	19.51	19.79	20.6	0
15	QPSK	1	37	19.13	19.35	19.67		
15	QPSK	1	74	19.11	19.41	19.76		
15	QPSK	36	0	19.26	19.45	19.82	20.6	0
15	QPSK	36	20	19.21	19.45	19.78		
15	QPSK	36	39	19.15	19.39	19.73		
15	QPSK	75	0	19.21	19.43	19.78	20.6	0
15	16QAM	1	0	19.66	19.82	20.14		
15	16QAM	1	37	19.46	19.62	20.03		
15	16QAM	1	74	19.45	19.69	20.03	20.6	0
15	16QAM	36	0	19.30	19.45	19.77		
15	16QAM	36	20	19.23	19.43	19.74		
15	16QAM	36	39	19.19	19.40	19.74	20.6	0
15	16QAM	75	0	19.23	19.41	19.77		
15	64QAM	1	0	19.60	19.74	20.03		
15	64QAM	1	37	19.40	19.58	19.89	20.6	0
15	64QAM	1	74	19.39	19.56	19.92		
15	64QAM	36	0	19.33	19.52	19.84		
15	64QAM	36	20	19.28	19.48	19.83	20.6	0
15	64QAM	36	39	19.23	19.45	19.78		
15	64QAM	75	0	19.23	19.45	19.79		





Channel				18650	18900	19150	Tune-up limit (dBm)	MPR (dB)
Frequency (MHz)				1855	1880	1905		
10	QPSK	1	0	19.52	19.61	19.74	20.6	0
10	QPSK	1	25	19.16	19.31	19.66		
10	QPSK	1	49	19.31	19.53	19.67		
10	QPSK	25	0	19.23	19.41	19.76	20.6	0
10	QPSK	25	12	19.19	19.41	19.74		
10	QPSK	25	25	19.16	19.37	19.73		
10	QPSK	50	0	19.20	19.40	19.76	20.6	0
10	16QAM	1	0	19.76	19.92	20.02		
10	16QAM	1	25	19.42	19.67	19.98		
10	16QAM	1	49	19.62	19.84	19.96	20.6	0
10	16QAM	25	0	19.26	19.43	19.72		
10	16QAM	25	12	19.24	19.38	19.75		
10	16QAM	25	25	19.20	19.37	19.69	20.6	0
10	16QAM	50	0	19.23	19.42	19.77		
10	64QAM	1	0	19.68	19.89	19.99		
10	64QAM	1	25	19.40	19.60	19.92	20.6	0
10	64QAM	1	49	19.56	19.76	19.89		
10	64QAM	25	0	19.29	19.46	19.82		
10	64QAM	25	12	19.24	19.43	19.80	20.6	0
10	64QAM	25	25	19.23	19.40	19.77		
10	64QAM	50	0	19.26	19.44	19.82		
Channel				18625	18900	19175	Tune-up limit (dBm)	MPR (dB)
Frequency (MHz)				1852.5	1880	1907.5		
5	QPSK	1	0	19.16	19.37	19.74	20.6	0
5	QPSK	1	12	19.10	19.30	19.67		
5	QPSK	1	24	19.14	19.33	19.70		
5	QPSK	12	0	19.19	19.41	19.76	20.6	0
5	QPSK	12	7	19.19	19.37	19.72		
5	QPSK	12	13	19.16	19.36	19.72		
5	QPSK	25	0	19.17	19.38	19.74	20.6	0
5	16QAM	1	0	19.51	19.76	20.07		
5	16QAM	1	12	19.44	19.68	20.04		
5	16QAM	1	24	19.47	19.71	20.03	20.6	0
5	16QAM	12	0	19.24	19.39	19.76		
5	16QAM	12	7	19.22	19.38	19.77		
5	16QAM	12	13	19.19	19.38	19.77	20.6	0
5	16QAM	25	0	19.18	19.38	19.75		
5	64QAM	1	0	19.47	19.66	19.97		
5	64QAM	1	12	19.35	19.58	19.94	20.6	0
5	64QAM	1	24	19.36	19.58	19.92		
5	64QAM	12	0	19.28	19.44	19.80		
5	64QAM	12	7	19.27	19.42	19.80	20.6	0
5	64QAM	12	13	19.27	19.44	19.79		
5	64QAM	25	0	19.22	19.40	19.78		



Channel				18615	18900	19185	Tune-up limit (dBm)	MPR (dB)
Frequency (MHz)				1851.5	1880	1908.5		
3	QPSK	1	0	19.12	19.30	19.46	20.6	0
3	QPSK	1	8	19.09	19.27	19.80		
3	QPSK	1	14	19.10	19.26	19.76		
3	QPSK	8	0	19.13	19.28	19.74	20.6	0
3	QPSK	8	4	19.20	19.29	19.78		
3	QPSK	8	7	19.16	19.35	19.71		
3	QPSK	15	0	19.13	19.36	19.71	20.6	0
3	16QAM	1	0	19.44	19.67	20.03		
3	16QAM	1	8	19.55	19.76	20.03		
3	16QAM	1	14	19.45	19.65	20.03	20.6	0
3	16QAM	8	0	19.22	19.39	19.75		
3	16QAM	8	4	19.24	19.42	19.81		
3	16QAM	8	7	19.18	19.38	19.76	20.6	0
3	16QAM	15	0	19.19	19.36	19.73		
3	64QAM	1	0	19.34	19.36	19.89		
3	64QAM	1	8	19.46	19.65	19.97	20.6	0
3	64QAM	1	14	19.35	19.54	19.89		
3	64QAM	8	0	19.23	19.43	19.79		
3	64QAM	8	4	19.24	19.43	19.78	20.6	0
3	64QAM	8	7	19.19	19.38	19.73		
3	64QAM	15	0	19.21	19.38	19.75		
Channel				18607	18900	19193	Tune-up limit (dBm)	MPR (dB)
Frequency (MHz)				1850.7	1880	1909.3		
1.4	QPSK	1	0	19.06	19.24	19.62	20.6	0
1.4	QPSK	1	3	19.13	19.35	19.72		
1.4	QPSK	1	5	19.04	19.25	19.59		
1.4	QPSK	3	0	19.09	19.31	19.65	20.6	0
1.4	QPSK	3	1	19.13	19.33	19.69		
1.4	QPSK	3	3	19.14	19.34	19.71		
1.4	QPSK	6	0	19.10	19.26	19.66	20.6	0
1.4	16QAM	1	0	19.42	19.57	19.91	20.6	0
1.4	16QAM	1	3	19.45	19.66	19.98		
1.4	16QAM	1	5	19.38	19.62	19.91		
1.4	16QAM	3	0	19.15	19.35	19.65	20.6	0
1.4	16QAM	3	1	19.19	19.39	19.74		
1.4	16QAM	3	3	19.16	19.36	19.70		
1.4	16QAM	6	0	19.17	19.35	19.71	20.6	0
1.4	64QAM	1	0	19.29	19.43	19.86	20.6	0
1.4	64QAM	1	3	19.33	19.52	19.92		
1.4	64QAM	1	5	19.27	19.44	19.84		
1.4	64QAM	3	0	19.27	19.50	19.81	20.6	0
1.4	64QAM	3	1	19.34	19.53	19.85		
1.4	64QAM	3	3	19.32	19.52	19.88		
1.4	64QAM	6	0	19.14	19.31	19.63	20.6	0



<LTE Band 4>

BW [MHz]	Modulation	RB Size	RB Offset	Power Low Ch. / Freq.	Power Middle Ch. / Freq.	Power High Ch. / Freq.	Tune-up limit (dBm)	MPR (dB)
Channel				20050	20175	20300		
Frequency (MHz)				1720	1732.5	1745		
20	QPSK	1	0	18.39	18.46	18.42	19.3	0
20	QPSK	1	49	18.13	18.17	18.21		
20	QPSK	1	99	18.15	18.15	18.21		
20	QPSK	50	0	18.32	18.37	18.47	19.3	0
20	QPSK	50	24	18.22	18.31	18.32		
20	QPSK	50	50	18.27	18.20	18.33		
20	QPSK	100	0	18.24	18.30	18.32	19.3	0
20	16QAM	1	0	18.71	18.70	18.69		
20	16QAM	1	49	18.38	18.42	18.56		
20	16QAM	1	99	18.40	18.49	18.55	19.3	0
20	16QAM	50	0	18.32	18.39	18.48		
20	16QAM	50	24	18.21	18.29	18.40		
20	16QAM	50	50	18.24	18.18	18.37	19.3	0
20	16QAM	100	0	18.22	18.26	18.40		
20	64QAM	1	0	18.51	18.61	18.54		
20	64QAM	1	49	18.27	18.31	18.38	19.3	0
20	64QAM	1	99	18.27	18.31	18.41		
20	64QAM	50	0	18.31	18.38	18.45		
20	64QAM	50	24	18.20	18.27	18.37	19.3	0
20	64QAM	50	50	18.22	18.18	18.35		
20	64QAM	100	0	18.22	18.27	18.40		
Channel				20025	20175	20325	Tune-up limit (dBm)	MPR (dB)
Frequency (MHz)				1717.5	1732.5	1747.5		
15	QPSK	1	0	18.35	18.42	18.47	19.3	0
15	QPSK	1	37	18.12	18.18	18.19		
15	QPSK	1	74	18.20	18.23	18.26		
15	QPSK	36	0	18.26	18.36	18.36	19.3	0
15	QPSK	36	20	18.21	18.27	18.29		
15	QPSK	36	39	18.27	18.21	18.31		
15	QPSK	75	0	18.20	18.29	18.31	19.3	0
15	16QAM	1	0	18.65	18.68	18.77		
15	16QAM	1	37	18.42	18.44	18.53		
15	16QAM	1	74	18.45	18.53	18.56	19.3	0
15	16QAM	36	0	18.30	18.36	18.45		
15	16QAM	36	20	18.22	18.24	18.37		
15	16QAM	36	39	18.28	18.17	18.37	19.3	0
15	16QAM	75	0	18.20	18.26	18.32		
15	64QAM	1	0	18.55	18.54	18.67		
15	64QAM	1	37	18.27	18.29	18.38	19.3	0
15	64QAM	1	74	18.34	18.39	18.43		
15	64QAM	36	0	18.27	18.34	18.43		
15	64QAM	36	20	18.22	18.23	18.37	19.3	0
15	64QAM	36	39	18.28	18.17	18.37		
15	64QAM	75	0	18.21	18.26	18.31		



Channel				20000	20175	20350	Tune-up limit (dBm)	MPR (dB)
Frequency (MHz)				1715	1732.5	1750		
10	QPSK	1	0	18.27	18.31	18.32	19.3	0
10	QPSK	1	25	18.13	18.18	18.27		
10	QPSK	1	49	18.10	18.13	18.21		
10	QPSK	25	0	18.23	18.29	18.30	19.3	0
10	QPSK	25	12	18.20	18.27	18.33		
10	QPSK	25	25	18.17	18.20	18.31		
10	QPSK	50	0	18.20	18.26	18.36	19.3	0
10	16QAM	1	0	18.58	18.54	18.66		
10	16QAM	1	25	18.42	18.41	18.61		
10	16QAM	1	49	18.37	18.37	18.53	19.3	0
10	16QAM	25	0	18.25	18.26	18.33		
10	16QAM	25	12	18.21	18.27	18.40		
10	16QAM	25	25	18.17	18.20	18.34	19.3	0
10	16QAM	50	0	18.21	18.24	18.39		
10	64QAM	1	0	18.39	18.42	18.47		
10	64QAM	1	25	18.27	18.34	18.47	19.3	0
10	64QAM	1	49	18.24	18.25	18.40		
10	64QAM	25	0	18.23	18.24	18.34		
10	64QAM	25	12	18.21	18.26	18.43	19.3	0
10	64QAM	25	25	18.16	18.17	18.33		
10	64QAM	50	0	18.19	18.23	18.37		
Channel				19975	20175	20375	Tune-up limit (dBm)	MPR (dB)
Frequency (MHz)				1712.5	1732.5	1752.5		
5	QPSK	1	0	18.22	18.23	18.37	19.3	0
5	QPSK	1	12	18.15	18.15	18.27		
5	QPSK	1	24	18.11	18.12	18.24		
5	QPSK	12	0	18.21	18.24	18.31	19.3	0
5	QPSK	12	7	18.24	18.23	18.32		
5	QPSK	12	13	18.21	18.20	18.28		
5	QPSK	25	0	18.19	18.23	18.31	19.3	0
5	16QAM	1	0	18.50	18.48	18.67		
5	16QAM	1	12	18.44	18.42	18.61		
5	16QAM	1	24	18.42	18.39	18.60	19.3	0
5	16QAM	12	0	18.22	18.23	18.37		
5	16QAM	12	7	18.25	18.24	18.40		
5	16QAM	12	13	18.20	18.20	18.31	19.3	0
5	16QAM	25	0	18.22	18.23	18.34		
5	64QAM	1	0	18.42	18.42	18.54		
5	64QAM	1	12	18.32	18.32	18.48	19.3	0
5	64QAM	1	24	18.32	18.32	18.42		
5	64QAM	12	0	18.25	18.29	18.38		
5	64QAM	12	7	18.27	18.28	18.37	19.3	0
5	64QAM	12	13	18.25	18.26	18.34		
5	64QAM	25	0	18.24	18.24	18.30		



Channel				19965	20175	20385	Tune-up limit (dBm)	MPR (dB)
Frequency (MHz)				1711.5	1732.5	1753.5		
3	QPSK	1	0	18.17	18.19	18.28	19.3	0
3	QPSK	1	8	18.21	18.23	18.35		
3	QPSK	1	14	18.10	18.15	18.22		
3	QPSK	8	0	18.20	18.23	18.31	19.3	0
3	QPSK	8	4	18.18	18.22	18.31		
3	QPSK	8	7	18.16	18.22	18.25		
3	QPSK	15	0	18.17	18.18	18.32	19.3	0
3	16QAM	1	0	18.43	18.41	18.64		
3	16QAM	1	8	18.52	18.55	18.73		
3	16QAM	1	14	18.41	18.41	18.58	19.3	0
3	16QAM	8	0	18.26	18.24	18.40		
3	16QAM	8	4	18.24	18.28	18.42		
3	16QAM	8	7	18.22	18.23	18.38	19.3	0
3	16QAM	15	0	18.17	18.22	18.35		
3	64QAM	1	0	18.39	18.35	18.46		
3	64QAM	1	8	18.45	18.43	18.53	19.3	0
3	64QAM	1	14	18.30	18.33	18.41		
3	64QAM	8	0	18.25	18.28	18.34		
3	64QAM	8	4	18.21	18.26	18.32	19.3	0
3	64QAM	8	7	18.20	18.25	18.32		
3	64QAM	15	0	18.23	18.19	18.28		
Channel				19957	20175	20393	Tune-up limit (dBm)	MPR (dB)
Frequency (MHz)				1710.7	1732.5	1754.3		
1.4	QPSK	1	0	18.07	18.07	18.20	19.3	0
1.4	QPSK	1	3	18.17	18.19	18.26		
1.4	QPSK	1	5	18.03	18.09	18.19		
1.4	QPSK	3	0	18.09	18.12	18.23		
1.4	QPSK	3	1	18.14	18.19	18.28		
1.4	QPSK	3	3	18.14	18.20	18.27		
1.4	QPSK	6	0	18.10	18.16	18.23	19.3	0
1.4	16QAM	1	0	18.34	18.37	18.53	19.3	0
1.4	16QAM	1	3	18.42	18.40	18.61		
1.4	16QAM	1	5	18.34	18.31	18.51		
1.4	16QAM	3	0	18.14	18.17	18.27		
1.4	16QAM	3	1	18.19	18.19	18.33		
1.4	16QAM	3	3	18.19	18.22	18.32		
1.4	16QAM	6	0	18.18	18.16	18.32	19.3	0
1.4	64QAM	1	0	18.28	18.29	18.40	19.3	0
1.4	64QAM	1	3	18.36	18.32	18.41		
1.4	64QAM	1	5	18.27	18.22	18.35		
1.4	64QAM	3	0	18.28	18.34	18.38		
1.4	64QAM	3	1	18.33	18.35	18.42		
1.4	64QAM	3	3	18.30	18.32	18.42		
1.4	64QAM	6	0	18.13	18.16	18.24	19.3	0



<LTE Band 7>

BW [MHz]	Modulation	RB Size	RB Offset	Power Low Ch. / Freq.	Power Middle Ch. / Freq.	Power High Ch. / Freq.	Tune-up limit (dBm)	MPR (dB)
Channel				20850	21100	21350	20.7	0
Frequency (MHz)				2510	2535	2560		
20	QPSK	1	0	19.85	19.75	19.84	20.7	0
20	QPSK	1	49	19.60	19.57	19.64		
20	QPSK	1	99	19.51	19.55	19.68		
20	QPSK	50	0	19.83	19.72	19.80	20.7	0
20	QPSK	50	24	19.73	19.70	19.77		
20	QPSK	50	50	19.67	19.64	19.73		
20	QPSK	100	0	19.82	19.69	19.77		
20	16QAM	1	0	20.12	20.00	20.11	20.7	0
20	16QAM	1	49	19.94	19.88	19.96		
20	16QAM	1	99	19.82	19.88	19.99		
20	16QAM	50	0	19.80	19.75	19.84	20.7	0
20	16QAM	50	24	19.77	19.73	19.84		
20	16QAM	50	50	19.72	19.68	19.78		
20	16QAM	100	0	19.74	19.71	19.79		
20	64QAM	1	0	20.00	19.93	20.04	20.7	0
20	64QAM	1	49	19.87	19.78	19.83		
20	64QAM	1	99	19.72	19.77	19.87		
20	64QAM	50	0	19.78	19.73	19.81	20.7	0
20	64QAM	50	24	19.73	19.67	19.80		
20	64QAM	50	50	19.67	19.62	19.76		
20	64QAM	100	0	19.72	19.66	19.80		
Channel				20825	21100	21375	20.7	0
Frequency (MHz)				2507.5	2535	2562.5		
15	QPSK	1	0	19.73	19.68	19.78	20.7	0
15	QPSK	1	37	19.61	19.54	19.68		
15	QPSK	1	74	19.60	19.53	19.66		
15	QPSK	36	0	19.73	19.66	19.77	20.7	0
15	QPSK	36	20	19.72	19.65	19.81		
15	QPSK	36	39	19.69	19.59	19.77		
15	QPSK	75	0	19.71	19.62	19.78		
15	16QAM	1	0	20.06	19.98	20.06	20.7	0
15	16QAM	1	37	19.91	19.84	19.96		
15	16QAM	1	74	19.90	19.89	19.99		
15	16QAM	36	0	19.75	19.71	19.84	20.7	0
15	16QAM	36	20	19.75	19.70	19.79		
15	16QAM	36	39	19.69	19.68	19.75		
15	16QAM	75	0	19.71	19.71	19.82		
15	64QAM	1	0	19.93	19.88	19.98	20.7	0
15	64QAM	1	37	19.77	19.78	19.85		
15	64QAM	1	74	19.80	19.76	19.86		
15	64QAM	36	0	19.75	19.68	19.83	20.7	0
15	64QAM	36	20	19.73	19.68	19.83		
15	64QAM	36	39	19.69	19.63	19.80		
15	64QAM	75	0	19.69	19.63	19.78		



Channel				20800	21100	21400	Tune-up limit (dBm)	MPR (dB)
Frequency (MHz)				2505	2535	2565		
10	QPSK	1	0	19.64	19.65	19.77	20.7	0
10	QPSK	1	25	19.62	19.56	19.69		
10	QPSK	1	49	19.57	19.53	19.65		
10	QPSK	25	0	19.68	19.61	19.78	20.7	0
10	QPSK	25	12	19.65	19.63	19.78		
10	QPSK	25	25	19.62	19.63	19.73		
10	QPSK	50	0	19.68	19.59	19.73	20.7	0
10	16QAM	1	0	19.96	19.95	20.04		
10	16QAM	1	25	19.92	19.86	19.96		
10	16QAM	1	49	19.85	19.84	19.98	20.7	0
10	16QAM	25	0	19.71	19.66	19.76		
10	16QAM	25	12	19.72	19.66	19.80		
10	16QAM	25	25	19.65	19.66	19.77	20.7	0
10	16QAM	50	0	19.73	19.69	19.78		
10	64QAM	1	0	19.85	19.76	19.93		
10	64QAM	1	25	19.78	19.73	19.90	20.7	0
10	64QAM	1	49	19.80	19.72	19.89		
10	64QAM	25	0	19.69	19.64	19.79		
10	64QAM	25	12	19.74	19.67	19.78	20.7	0
10	64QAM	25	25	19.68	19.59	19.73		
10	64QAM	50	0	19.68	19.62	19.80		
Channel				20775	21100	21425	Tune-up limit (dBm)	MPR (dB)
Frequency (MHz)				2502.5	2535	2567.5		
5	QPSK	1	0	19.63	19.56	19.72	20.7	0
5	QPSK	1	12	19.61	19.56	19.71		
5	QPSK	1	24	19.59	19.52	19.68		
5	QPSK	12	0	19.69	19.63	19.73	20.7	0
5	QPSK	12	7	19.67	19.66	19.73		
5	QPSK	12	13	19.63	19.59	19.75		
5	QPSK	25	0	19.63	19.59	19.77	20.7	0
5	16QAM	1	0	19.90	19.91	20.02		
5	16QAM	1	12	19.93	19.89	20.03		
5	16QAM	1	24	19.90	19.82	20.00	20.7	0
5	16QAM	12	0	19.72	19.67	19.80		
5	16QAM	12	7	19.71	19.69	19.81		
5	16QAM	12	13	19.68	19.63	19.81	20.7	0
5	16QAM	25	0	19.67	19.61	19.74		
5	64QAM	1	0	19.81	19.74	19.87		
5	64QAM	1	12	19.78	19.74	19.89	20.7	0
5	64QAM	1	24	19.74	19.71	19.83		
5	64QAM	12	0	19.70	19.67	19.78		
5	64QAM	12	7	19.73	19.68	19.85	20.7	0
5	64QAM	12	13	19.72	19.66	19.78		
5	64QAM	25	0	19.69	19.63	19.76		



<LTE Band 66>

BW [MHz]	Modulation	RB Size	RB Offset	Power Low Ch. / Freq.	Power Middle Ch. / Freq.	Power High Ch. / Freq.	Tune-up limit (dBm)	MPR (dB)
Channel				132072	132322	132572	19.3	0
Frequency (MHz)				1720	1745	1770		
20	QPSK	1	0	18.25	18.29	18.33	19.3	0
20	QPSK	1	49	17.99	18.07	17.91		
20	QPSK	1	99	17.96	17.94	17.77		
20	QPSK	50	0	18.16	18.27	18.29	19.3	0
20	QPSK	50	24	18.06	18.21	18.04		
20	QPSK	50	50	18.10	18.10	17.96		
20	QPSK	100	0	18.07	18.21	18.27		
20	16QAM	1	0	18.58	18.54	18.54	19.3	0
20	16QAM	1	49	18.30	18.34	18.22		
20	16QAM	1	99	18.24	18.23	18.09		
20	16QAM	50	0	18.20	18.31	18.17	19.3	0
20	16QAM	50	24	18.12	18.22	18.04		
20	16QAM	50	50	18.10	18.10	17.94		
20	16QAM	100	0	18.08	18.23	18.05		
20	64QAM	1	0	18.40	18.48	18.48	19.3	0
20	64QAM	1	49	18.13	18.32	18.15		
20	64QAM	1	99	18.17	18.17	17.97		
20	64QAM	50	0	18.20	18.29	18.16	19.3	0
20	64QAM	50	24	18.10	18.20	18.04		
20	64QAM	50	50	18.13	18.10	17.96		
20	64QAM	100	0	18.10	18.24	18.07		
Channel				132047	132322	132597	19.3	0
Frequency (MHz)				1717.5	1745	1772.5		
15	QPSK	1	0	18.22	18.31	18.16	19.3	0
15	QPSK	1	37	17.97	18.06	17.90		
15	QPSK	1	74	18.04	18.01	17.83		
15	QPSK	36	0	18.16	18.26	18.08	19.3	0
15	QPSK	36	20	18.10	18.17	18.03		
15	QPSK	36	39	18.02	18.11	17.94		
15	QPSK	75	0	18.10	18.15	18.00		
15	16QAM	1	0	18.54	18.64	18.47	19.3	0
15	16QAM	1	37	18.32	18.42	18.19		
15	16QAM	1	74	18.34	18.33	18.14		
15	16QAM	36	0	18.17	18.28	18.10	19.3	0
15	16QAM	36	20	18.14	18.19	18.04		
15	16QAM	36	39	18.06	18.14	17.92		
15	16QAM	75	0	18.07	18.18	18.01		
15	64QAM	1	0	18.39	18.46	18.37	19.3	0
15	64QAM	1	37	18.16	18.22	18.10		
15	64QAM	1	74	18.19	18.18	18.03		
15	64QAM	36	0	18.17	18.28	18.12	19.3	0
15	64QAM	36	20	18.11	18.22	18.05		
15	64QAM	36	39	18.03	18.13	17.98		
15	64QAM	75	0	18.08	18.18	18.02		





Channel				132022	132322	132622	Tune-up limit (dBm)	MPR (dB)
Frequency (MHz)				1715	1745	1775		
10	QPSK	1	0	18.13	18.23	18.01	19.3	0
10	QPSK	1	25	18.02	18.09	17.89		
10	QPSK	1	49	17.95	18.01	17.81		
10	QPSK	25	0	18.12	18.19	18.03	19.3	0
10	QPSK	25	12	18.04	18.14	17.94		
10	QPSK	25	25	17.99	18.12	17.90		
10	QPSK	50	0	18.07	18.15	17.93	19.3	0
10	16QAM	1	0	18.50	18.51	18.34		
10	16QAM	1	25	18.34	18.37	18.19		
10	16QAM	1	49	18.27	18.30	18.12	19.3	0
10	16QAM	25	0	18.14	18.20	18.02		
10	16QAM	25	12	18.08	18.16	17.95		
10	16QAM	25	25	18.04	18.10	17.91	19.3	0
10	16QAM	50	0	18.11	18.17	17.97		
10	64QAM	1	0	18.28	18.38	18.21		
10	64QAM	1	25	18.12	18.29	18.06	19.3	0
10	64QAM	1	49	18.10	18.23	18.00		
10	64QAM	25	0	18.13	18.20	18.04		
10	64QAM	25	12	18.09	18.18	18.00	19.3	0
10	64QAM	25	25	18.05	18.13	17.92		
10	64QAM	50	0	18.10	18.16	17.98		
Channel				131997	132322	132647	Tune-up limit (dBm)	MPR (dB)
Frequency (MHz)				1712.5	1745	1777.5		
5	QPSK	1	0	18.05	18.13	17.95	19.3	0
5	QPSK	1	12	17.98	18.06	17.88		
5	QPSK	1	24	17.95	18.05	17.82		
5	QPSK	12	0	18.05	18.17	17.96	19.3	0
5	QPSK	12	7	18.05	18.11	17.92		
5	QPSK	12	13	18.03	18.09	17.90		
5	QPSK	25	0	18.06	18.11	17.92	19.3	0
5	16QAM	1	0	18.39	18.49	18.24		
5	16QAM	1	12	18.32	18.39	18.15		
5	16QAM	1	24	18.28	18.36	18.13	19.3	0
5	16QAM	12	0	18.09	18.14	17.98		
5	16QAM	12	7	18.09	18.14	17.94		
5	16QAM	12	13	18.03	18.12	17.91	19.3	0
5	16QAM	25	0	18.06	18.13	17.93		
5	64QAM	1	0	18.26	18.32	18.14		
5	64QAM	1	12	18.19	18.22	18.04	19.3	0
5	64QAM	1	24	18.17	18.21	18.02		
5	64QAM	12	0	18.13	18.18	18.00		
5	64QAM	12	7	18.09	18.17	18.00	19.3	0
5	64QAM	12	13	18.07	18.17	17.95		
5	64QAM	25	0	18.05	18.12	17.94		



Channel				131987	132322	132657	Tune-up limit (dBm)	MPR (dB)
Frequency (MHz)				1711.5	1745	1778.5		
3	QPSK	1	0	18.02	18.06	17.89	19.3	0
3	QPSK	1	8	18.06	18.18	17.87		
3	QPSK	1	14	18.02	18.07	17.94		
3	QPSK	8	0	18.05	18.10	17.88	19.3	0
3	QPSK	8	4	18.04	18.10	17.90		
3	QPSK	8	7	18.00	18.10	17.88		
3	QPSK	15	0	18.05	18.10	17.92	19.3	0
3	16QAM	1	0	18.31	18.36	18.22		
3	16QAM	1	8	18.41	18.46	18.26		
3	16QAM	1	14	18.26	18.33	18.15	19.3	0
3	16QAM	8	0	18.12	18.20	18.00		
3	16QAM	8	4	18.13	18.19	17.98		
3	16QAM	8	7	18.11	18.13	17.96	19.3	0
3	16QAM	15	0	18.04	18.11	17.89		
3	64QAM	1	0	18.23	18.27	18.12		
3	64QAM	1	8	18.27	18.33	18.13	19.3	0
3	64QAM	1	14	18.18	18.20	18.00		
3	64QAM	8	0	18.07	18.15	17.96		
3	64QAM	8	4	18.10	18.16	17.95	19.3	0
3	64QAM	8	7	18.05	18.14	17.93		
3	64QAM	15	0	18.05	18.13	17.91		
Channel				131979	132322	132665	Tune-up limit (dBm)	MPR (dB)
Frequency (MHz)				1710.7	1745	1779.3		
1.4	QPSK	1	0	17.90	17.99	17.81	19.3	0
1.4	QPSK	1	3	17.99	18.06	17.85		
1.4	QPSK	1	5	17.89	17.96	17.75		
1.4	QPSK	3	0	17.97	18.03	17.84	19.3	0
1.4	QPSK	3	1	18.01	18.08	17.88		
1.4	QPSK	3	3	17.99	18.07	17.87		
1.4	QPSK	6	0	17.93	18.03	17.82	19.3	0
1.4	16QAM	1	0	18.26	18.24	18.10	19.3	0
1.4	16QAM	1	3	18.29	18.33	18.17		
1.4	16QAM	1	5	18.21	18.26	18.06		
1.4	16QAM	3	0	17.99	18.06	17.88	19.3	0
1.4	16QAM	3	1	18.02	18.10	17.89		
1.4	16QAM	3	3	18.01	18.11	17.87		
1.4	16QAM	6	0	18.03	18.09	17.91	19.3	0
1.4	64QAM	1	0	18.11	18.20	18.02	19.3	0
1.4	64QAM	1	3	18.18	18.22	18.04		
1.4	64QAM	1	5	18.11	18.17	17.98		
1.4	64QAM	3	0	18.11	18.21	17.99	19.3	0
1.4	64QAM	3	1	18.15	18.27	18.04		
1.4	64QAM	3	3	18.14	18.24	18.02		
1.4	64QAM	6	0	17.97	18.04	17.87	19.3	0



<LTE Carrier Aggregation>

General Note:

This device supports Carrier Aggregation on downlink for inter and intra band. For the device supports bands and bandwidths and configurations are provided as follow table was according to 3GPP.

<Inter-Band for Two Carrier Combination>

E-UTRA CA configuration / Bandwidth combination set										
E-UTRA CA Configuration	Uplink CA configurations	E- UTRA Bands	1.4 MHz	3 MHz	5 MHz	10 MHz	15 MHz	20 MHz	Maximum aggregated bandwidth [MHz]	Bandwidth combination set
CA_2A-4A	-	2	Yes	Yes	Yes	Yes	Yes	Yes	40	0
		4			Yes	Yes	Yes	Yes		
		2			Yes	Yes			20	1
		4			Yes	Yes				
		2			Yes	Yes	Yes	Yes	40	2
4			Yes	Yes	Yes	Yes				
CA_2A-5A	-	2			Yes	Yes	Yes	Yes	30	0
		5			Yes	Yes				
		2			Yes	Yes			20	1
		5			Yes	Yes				
CA_2A-13A	-	2			Yes	Yes	Yes	Yes	30	0
		13				Yes				
		2			Yes	Yes			20	1
13				Yes						
CA_2A-46A	-	2			Yes	Yes	Yes	Yes	40	0
		46						Yes		
CA_2A-66A	-	2	Yes	Yes	Yes	Yes	Yes	Yes	40	0
		66			Yes	Yes	Yes	Yes		
		2			Yes	Yes			20	1
		66			Yes	Yes				
		2			Yes	Yes	Yes	Yes	40	2
66			Yes	Yes	Yes	Yes				
CA_4A-5A	-	4			Yes	Yes			20	0
		5			Yes	Yes				
		4			Yes	Yes	Yes	Yes	30	0
		5			Yes	Yes				
CA_4A-13A	-	4			Yes	Yes	Yes	Yes	30	0
		13				Yes				
		4			Yes	Yes			20	1
		13				Yes				
CA_4A-46A	-	4			Yes	Yes	Yes	Yes	40	0
		46						Yes		
CA_5A-66A	-	5			Yes	Yes			30	0
		66			Yes	Yes	Yes	Yes		
CA_13A-46A	-	13			Yes	Yes			30	0
		46						Yes		
CA_13A-66A	-	13			Yes	Yes			30	0
		66			Yes	Yes	Yes	Yes		
CA_66A-46A	-	66			Yes	Yes	Yes	Yes	40	0
		46						Yes		



<Inter-Band for Three Carrier Combination>

E-UTRA CA configuration / Bandwidth combination set										
E-UTRA CA Configuration	Uplink CA configurations	E-UTRA Bands	1.4 MHz	3 MHz	5 MHz	10 MHz	15 MHz	20 MHz	Maximum aggregated bandwidth [MHz]	Bandwidth combination set
CA_2A-2A-4A	-	2	See CA_2A-2A Bandwidth Combination Set 0 in Table 5.6A.1-3				60	0		
		4			Yes	Yes			Yes	Yes
CA_2A-4A-4A	-	2			Yes	Yes	Yes	Yes	60	0
		4	See CA_4A-4A Bandwidth Combination Set 0 in Table 5.6A.1-3							
CA_2A-2A-5A	-	2	See CA_2A-2A Bandwidth Combination Set 0 in Table 5.6A.1-3				50	0		
		5			Yes	Yes				
CA_2A-2A-13A	-	2	See CA_2A-2A Bandwidth Combination Set 0 in Table 5.6A.1-3				50	0		
		13				Yes				
CA_2A-46A-46A	-	2			Yes	Yes	Yes	Yes	60	0
		46	See CA_46A-46A Bandwidth Combination Set 0 in Table 5.6A.1-3							
CA_2A-46C	-	2			Yes	Yes	Yes	Yes	60	0
		46	See CA_46C Bandwidth Combination Set 0 in Table 5.6A.1-1							
CA_2A-2A-66A	-	2	See CA_2A-2A Bandwidth Combination Set 0 in Table 5.6A.1-3				60	0		
		66			Yes	Yes			Yes	Yes
CA_2A-66A-66A	-	2			Yes	Yes	Yes	Yes	60	0
		66	See CA_66A-66A Bandwidth Combination Set 0 in Table 5.6A.1-3							
CA_2A-66B	-	2			Yes	Yes	Yes	Yes	40	0
		66	See CA_66B Bandwidth Combination Set 0 in Table 5.6A.1-1							
CA_2A-66C	-	2			Yes	Yes	Yes	Yes	60	0
		66	See CA_66C Bandwidth Combination Set 0 in Table 5.6A.1-1							
CA_2A-4A-5A	-	2			Yes	Yes	Yes	Yes	50	0
		4			Yes	Yes	Yes	Yes		
		5			Yes	Yes				
CA_2A-4A-13A	-	2			Yes	Yes	Yes	Yes	50	0
		4			Yes	Yes	Yes	Yes		
		13				Yes				
CA_2A-5A-66A	-	2			Yes	Yes	Yes	Yes	50	0
		5			Yes	Yes				
		66			Yes	Yes	Yes	Yes		
CA_2A-13A-66A	-	2			Yes	Yes	Yes	Yes	50	0
		13			Yes	Yes				
		66			Yes	Yes	Yes	Yes		



E-UTRA CA configuration / Bandwidth combination set										
E-UTRA CA Configuration	Uplink CA configurations	E-UTRA Bands	1.4 MHz	3 MHz	5 MHz	10 MHz	15 MHz	20 MHz	Maximum aggregated bandwidth [MHz]	Bandwidth combination set
CA_4A-4A-5A	-	4	See CA_4A-4A Bandwidth Combination Set 0 in Table 5.6A.1-3						50	0
		5			Yes	Yes				
CA_4A-4A-13A	-	4	See CA_4A-4A Bandwidth Combination Set 0 in Table 5.6A.1-3						50	0
		13				Yes				
CA_4A-46A-46A	-	4			Yes	Yes	Yes	Yes	60	0
		46	See CA_46A-46A Bandwidth Combination Set 0 in Table 5.6A.1-3							
CA_4A-46C	-	4			Yes	Yes	Yes	Yes	60	0
		46	See CA_46C Bandwidth Combination Set 0 in Table 5.6A.1-1							
CA_5A-66A-66A	-	5			Yes	Yes			50	0
		66	See CA_66A-66A Bandwidth Combination Set 0 in Table 5.6A.1-3							
CA_5A-66B	-	5			Yes	Yes			30	0
		66	See CA_66B Bandwidth Combination Set 0 in Table 5.6A.1-1							
CA_5A-66C	-	5			Yes	Yes			50	0
		66	See CA_66C Bandwidth Combination Set 0 in Table 5.6A.1-1							
CA_13A-66A-66A	-	13			Yes	Yes			50	0
		66	See CA_66A-66A Bandwidth Combination Set 0 in Table 5.6A.1-3							
CA_13A-66B	-	13			Yes	Yes			30	0
		66	See CA_66B Bandwidth Combination Set 0 in Table 5.6A.1-1							
CA_13A-66C	-	13			Yes	Yes			50	0
		66	See CA_66C Bandwidth Combination Set 0 in Table 5.6A.1-1							
CA_66A-46C	-	66			Yes	Yes	Yes	Yes	60	0
		46	See CA_46C Bandwidth Combination Set 0 in Table 5.6A.1-1							

**<Intra-Band Carrier Combination> (Contiguous)**

E-UTRA CA configuration / Bandwidth combination set							
E-UTRA CA configuration	Uplink CA configurations	Component carriers in order of increasing carrier frequency				Maximum aggregated bandwidth [MHz]	Bandwidth combination set
		Channel bandwidths for carrier [MHz]	Channel bandwidths for carrier [MHz]	Channel bandwidths for carrier [MHz]	Channel bandwidths for carrier [MHz]		
CA_5B	-	5, 10	10			20	0
		10	5				
		3	5			8	1
		5	3				
CA_66B	-	5	5, 10, 15			20	0
		10	5, 10				
		15	5				
CA_66C	-	5	20			40	0
		10	15, 20				
		15	10, 15, 20				
		20	5, 10, 15, 20				

**<Intra-Band Carrier Combination> (Non-Contiguous)**

E-UTRA CA configuration / Bandwidth combination set							
E-UTRA CA configuration	Uplink CA configurations	Component carriers in order of increasing carrier frequency				Maximum aggregated bandwidth [MHz]	Bandwidth combination set
		Channel bandwidths for carrier [MHz]	Channel bandwidths for carrier [MHz]	Channel bandwidths for carrier [MHz]	Channel bandwidths for carrier [MHz]		
CA_2A-2A	-	5, 10, 15, 20	5, 10, 15, 20			40	0
CA_4A-4A	-	5, 10, 15, 20	5, 10, 15, 20			40	0
		5, 10	5, 10			20	1
CA_66A-66A	-	5, 10, 15, 20	5, 10, 15, 20			40	0
CA_66A-66C	-	5, 10, 15, 20	See CA_66C Bandwidth Combination Set 0 in Table 5.6A.1-1			60	0
		See CA_66C Bandwidth Combination Set 0 in Table 5.6A.1-1			5, 10, 15, 20		

**<DL CA power measurement>**

**General Note:**

1. This device supports Carrier Aggregation on downlink for inter and intra band. For the device supports bands and bandwidths and configurations are provided as follow table was according to 3GPP.
2. In applying the existing power measurement procedures of KDB 941225 D05A for DL CA SAR test exclusion, only the subset with the largest number of combinations of frequency bands and CCs in each row need combination, and for this device that only yellow highlighted cells need power measurement.

Index	2CC	Restriction	Completely Covered by Measurement Superset	Index	3CC	Restriction	Completely Covered by Measurement Superset
2CC #1	CA_2A-4A		3CC #2	3CC #1	CA_2A-2A-4A		No
2CC #2	CA_2A-5A		3CC #3	3CC #2	CA_2A-4A-4A		No
2CC #3	CA_2A-13A		3CC #4	3CC #3	CA_2A-2A-5A		No
2CC #4	CA_2A-46A	B46 SCC Only	3CC #5	3CC #4	CA_2A-2A-13A		No
2CC #5	CA_2A-66A		3CC #8	3CC #5	CA_2A-46A-46A	B46 SCC Only	No
2CC #6	CA_2A-2A		3CC #1	3CC #6	CA_2A-46C	B46 SCC Only	No
2CC #7	CA_4A-5A		3CC #11	3CC #7	CA_2A-2A-66A		No
2CC #8	CA_4A-13A		3CC #12	3CC #8	CA_2A-66A-66A		No
2CC #9	CA_4A-46A	B46 SCC Only	3CC #17	3CC #9	CA_2A-66B		No
2CC #10	CA_4A-4A		3CC #15	3CC #10	CA_2A-66C		No
2CC #11	CA_5A-66A		3CC #19	3CC #11	CA_2A-4A-5A		No
2CC #12	CA_5B		No	3CC #12	CA_2A-4A-13A		No
2CC #13	CA_13A-46A	B46 SCC Only	No	3CC #13	CA_2A-5A-66A		No
2CC #14	CA_13A-66A		3CC #22	3CC #14	CA_2A-13A-66A		No
2CC #15	CA_66A-46A	B46 SCC Only	3CC #25	3CC #15	CA_4A-4A-5A		No
2CC #16	CA_66A-66A		3CC #8	3CC #16	CA_4A-4A-13A		No
2CC #17	CA_66B		3CC #9	3CC #17	CA_4A-46A-46A	B46 SCC Only	No
2CC #18	CA_66C		3CC #10	3CC #18	CA_4A-46C	B46 SCC Only	No
				3CC #19	CA_5A-66A-66A		No
				3CC #20	CA_5A-66B		No
				3CC #21	CA_5A-66C		No
				3CC #22	CA_13A-66A-66A		No
				3CC #23	CA_13A-66B		No
				3CC #24	CA_13A-66C		No
				3CC #25	CA_66A-46C	B46 SCC Only	No
				3CC #26	CA_66A-66C		No

### LTE Carrier Aggregation Conducted Power (Downlink)

#### General Note:

- i. According to KDB941225 D05A v01r02, Uplink maximum output power measurement with downlink carrier aggregation active should be measured, using the highest output channel measured without downlink carrier aggregation, to confirm that uplink maximum output power with downlink carrier aggregation active remains within the specified tune-up tolerance limits and not more than ¼ dB higher than the maximum output measured without downlink carrier aggregation active.
- ii. Uplink maximum output power with downlink carrier aggregation active does not show more than ¼ dB higher than the maximum output power without downlink carrier aggregation active, therefore SAR evaluation with downlink carrier aggregation active can be excluded.
- iii. The device supports downlink carrier aggregation only. Uplink carrier aggregation is not supported. For power measurement were control and acknowledge data is sent on uplink channels that operate identical to specifications when downlink carrier aggregation is inactive.
- iv. Selected highest measured power when downlink carrier aggregation is inactive for conducted power comparison with downlink carrier aggregation is active, to confirm that when downlink carrier aggregation is active uplink maximum output power remains within the specified tune-up tolerance limits and not more than ¼ dB higher than the maximum output power measured when downlink carrier aggregation inactive.
- v. For inter-band CA, the SCC selected highest bandwidth and near the middle of its transmission band. For SCC DL RB size and offset will base on the PCC corresponding RB allocation.
- vi. For non-contiguous intra-band CA, the SCC selected to provide maximum separation from the PCC and must remain fully within the downlink transmission band. For SCC DL RB size and offset will base on the PCC corresponding RB allocation.
- vii. For Intra-band, contiguous CA, the downlink channels selected to perform the uplink power measurement must satisfy 3GPP channel spacing (5.4.1A of 3GPP TS 36.521 or equivalent) and channel bandwidth (5.4.2A) requirements.

$$\text{Nominal channel spacing} = \left\lceil \frac{BW_{\text{Channel}(1)} + BW_{\text{Channel}(2)} - 0.1|BW_{\text{Channel}(1)} - BW_{\text{Channel}(2)}|}{0.6} \right\rceil 0.3 \text{ [MHz]}$$





**<Full Power Mode>**

**<Two Carrier power verification>**

Configure	CA Configuration (BCS)	PCC							SCC				Power	
		LTE Band	BW (MHz)	UL Freq. (MHz)	UL Channel	Mod.	UL# RB	UL RB Offset	LTE Band	BW (MHz)	DL Freq. (MHz)	DL Channel	With CA Tx. Power (dBm)	Without CA Tx. Power (dBm)
Inter-Band	CA_13A-46A	13	10M	782	23230	QPSK	1	0	46	20M	5540	50690	22.92	23.00
Intra-Band Contiguous	CA_5B	5	10M	844	20600	QPSK	1	25	5	10M	879.1	2501	23.28	23.30

**<Three Carrier power verification>**

Configure	CA Configuration (BCS)	PCC							SCC1				SCC2				Power	
		LTE Band	BW (MHz)	UL Freq. (MHz)	UL Channel	Mod.	UL# RB	UL RB Offset	LTE Band	BW (MHz)	DL Freq. (MHz)	DL Channel	LTE Band	BW (MHz)	DL Freq. (MHz)	DL Channel	With CA Tx. Power (dBm)	Without CA Tx. Power (dBm)
Inter-Band	CA_2A-2A-4A	2	20M	1900	19100	QPSK	1	0	2	5M	1932.5	625	4	20M	2132.5	2175	23.21	23.33
		4	20M	1732.5	20175	QPSK	1	0	2	20M	1960	900	2	5M	1987.5	1175	23.12	23.23
	CA_2A-4A-4A	2	20M	1900	19100	QPSK	1	0	4	20M	2132.5	2175	4	5M	2152.5	2375	23.26	23.33
		4	20M	1732.5	20175	QPSK	1	0	4	5M	2152.5	2375	2	20M	1960	900	23.16	23.23
	CA_2A-2A-5A	2	20M	1900	19100	QPSK	1	0	2	5M	1932.5	625	5	10M	881.5	2525	23.25	23.33
		5	10M	844	20600	QPSK	1	25	2	20M	1960	900	2	5M	1987.5	1175	23.16	23.30
	CA_2A-2A-13A	2	20M	1900	19100	QPSK	1	0	2	5M	1932.5	625	13	10M	751	5230	23.21	23.33
		13	10M	782	23230	QPSK	1	0	2	20M	1960	900	2	5M	1987.5	1175	23.18	23.00
	CA_2A-46A-46A	2	20M	1900	19100	QPSK	1	0	46	20M	5540	50690	46	20M	5160	46890	23.31	23.33
		2	20M	1900	19100	QPSK	1	0	46	20M	5540	50690	46	20M	5559.8	50888	23.28	23.33
	CA_2A-2A-66A	2	20M	1900	19100	QPSK	1	0	2	5M	1932.5	625	66	20M	2155	66886	23.25	23.33
		66	20M	1770	132572	QPSK	1	0	2	20M	1960	900	2	5M	1987.5	1175	23.03	23.10
	CA_2A-66A-66A	2	20M	1900	19100	QPSK	1	0	66	20M	2155	66886	66	5M	2197.5	67311	23.28	23.33
		66	20M	1770	132572	QPSK	1	0	66	5M	2112.5	66461	2	20M	1960	900	23.06	23.10
	CA_2A-66B	2	20M	1900	19100	QPSK	1	0	66	15M	2155	66886	66	5M	2164.3	66979	23.26	23.33
		66	15M	1772.5	132597	QPSK	1	0	66	5M	2188.2	67218	2	20M	1960	900	22.96	23.04
	CA_2A-66C	2	20M	1900	19100	QPSK	1	0	66	20M	2155	66886	66	20M	2174.8	67084	23.29	23.33
		66	20M	1770	132572	QPSK	1	0	66	20M	2170.2	67038	2	20M	1960	900	23.05	23.10
	CA_2A-4A-5A	2	20M	1900	19100	QPSK	1	0	4	20M	2132.5	2175	5	10M	881.5	2525	23.25	23.33
		4	20M	1732.5	20175	QPSK	1	0	5	10M	881.5	2525	2	20M	1960	900	23.13	23.23
		5	10M	844	20600	QPSK	1	25	2	20M	1960	900	4	20M	2132.5	2175	23.21	23.30
	CA_2A-4A-13A	2	20M	1900	19100	QPSK	1	0	4	20M	2132.5	2175	13	10M	751	5230	23.26	23.33
		4	20M	1732.5	20175	QPSK	1	0	13	10M	751	5230	2	20M	1960	900	23.26	23.23
		13	10M	782	23230	QPSK	1	0	2	20M	1960	900	4	20M	2132.5	2175	22.94	23.00
	CA_2A-5A-66A	2	20M	1900	19100	QPSK	1	0	5	10M	881.5	2525	66	20M	2155	66886	23.21	23.33
		5	10M	844	20600	QPSK	1	25	66	20M	2155	66886	2	20M	1960	900	23.26	23.30
		66	20M	1770	132572	QPSK	1	0	2	20M	1960	900	5	10M	881.5	2525	23.01	23.10
	CA_2A-13A-66A	2	20M	1900	19100	QPSK	1	0	13	10M	751	5230	66	20M	2155	66886	23.26	23.33
		13	10M	782	23230	QPSK	1	0	66	20M	2155	66886	2	20M	1960	900	22.95	23.00
		66	20M	1770	132572	QPSK	1	0	2	20M	1960	900	13	10M	751	5230	23.02	23.10
CA_4A-4A-5A	4	20M	1732.5	20175	QPSK	1	0	4	5M	2152.5	2375	5	10M	881.5	2525	23.16	23.23	
	5	10M	844	20600	QPSK	1	25	4	20M	2132.5	2175	4	5M	2152.5	2375	23.21	23.30	
CA_4A-4A-13A	4	20M	1732.5	20175	QPSK	1	0	4	5M	2152.5	2375	13	10M	751	5230	23.12	23.23	
	13	10M	782	23230	QPSK	1	0	4	20M	2132.5	2175	4	5M	2152.5	2375	22.94	23.00	
CA_4A-46A-46A	4	20M	1732.5	20175	QPSK	1	0	46	20M	5540	50690	46	20M	5160	46890	23.22	23.23	
	4	20M	1732.5	20175	QPSK	1	0	46	20M	5540	50690	46	20M	5559.8	50888	23.18	23.23	



Configure	CA Configuration (BCS)	PCC							SCC1				SCC2				Power		
		LTE Band	BW (MHz)	UL Freq. (MHz)	UL Channel	Mod.	UL# RB	UL RB Offset	LTE Band	BW (MHz)	DL Freq. (MHz)	DL Channel	LTE Band	BW (MHz)	DL Freq. (MHz)	DL Channel	With CA Tx. Power (dBm)	Without CA Tx. Power (dBm)	
Inter-Band	CA_5A-66A-66A	5	10M	844	20600	QPSK	1	25	66	20M	2155	66886	66	5M	2197.5	67311	23.21	23.30	
		66	20M	1770	132572	QPSK	1	0	66	5M	2112.5	66461	5	10M	881.5	2525	23.04	23.10	
	CA_5A-66B	5	10M	844	20600	QPSK	1	25	66	15M	2155	66886	66	5M	2164.3	66979	23.24	23.30	
		66	15M	1772.5	132597	QPSK	1	0	66	5M	2188.2	67218	5	10M	881.5	2525	22.98	23.04	
	CA_5A-66C	5	10M	844	20600	QPSK	1	25	66	20M	2155	66886	66	20M	2174.8	67084	23.09	23.30	
		66	20M	1770	132572	QPSK	1	0	66	20M	2170.2	67038	5	10M	881.5	2525	22.94	23.10	
	CA_13A-66A-66A	13	10M	782	23230	QPSK	1	0	66	20M	2155	66886	66	5M	2197.5	67311	22.95	23.00	
		66	20M	1770	132572	QPSK	1	0	66	5M	2112.5	66461	13	10M	751	5230	22.98	23.10	
	CA_13A-66B	13	10M	782	23230	QPSK	1	0	66	15M	2155	66886	66	5M	2164.3	66979	22.97	23.00	
		66	15M	1772.5	132597	QPSK	1	0	66	5M	2188.2	67218	13	10M	751	5230	22.94	23.04	
	CA_13A-66C	13	10M	782	23230	QPSK	1	0	66	20M	2155	66886	66	20M	2174.8	67084	22.95	23.00	
		66	20M	1770	132572	QPSK	1	0	66	20M	2170.2	67038	13	10M	751	5230	22.91	23.10	
	CA_66A-46C	66	20M	1770	132572	QPSK	1	0	46	20M	5540	50690	46	20M	5559.8	50888	23.08	23.10	
		66	20M	1770	132572	QPSK	1	0	66	5M	2112.5	66461	66	20M	2124.2	66578	23.05	23.10	
Intra-Band	Non-Contiguous	CA_66A-66C	66	20M	1770	132572	QPSK	1	0	66	20M	2170.2	67038	66	5M	2112.5	66461	22.98	23.10
			66	20M	1770	132572	QPSK	1	0	66	20M	2170.2	67038	66	5M	2112.5	66461	22.98	23.10



<Reduced Power Mode for Hotspot On >

<Two Carrier power verification>

Configure	CA Configuration (BCS)	PCC							SCC				Power	
		LTE Band	BW (MHz)	UL Freq. (MHz)	UL Channel	Mod.	UL# RB	UL RB Offset	LTE Band	BW (MHz)	DL Freq. (MHz)	DL Channel	With CA Tx. Power (dBm)	Without CA Tx. Power (dBm)
Inter-Band	CA_13A-46A	13	10M	782	23230	16QAM	1	0	46	20M	5540	50690	21.36	21.43
Intra-Band Contiguous	CA_5B	5	10M	844	20600	16QAM	1	0	5	10M	879.1	2501	21.28	21.31

<Three Carrier power verification>

Configure	CA Configuration (BCS)	PCC							SCC1				SCC2				Power	
		LTE Band	BW (MHz)	UL Freq. (MHz)	UL Channel	Mod.	UL# RB	UL RB Offset	LTE Band	BW (MHz)	DL Freq. (MHz)	DL Channel	LTE Band	BW (MHz)	DL Freq. (MHz)	DL Channel	With CA Tx. Power (dBm)	Without CA Tx. Power (dBm)
Inter-Band	CA_2A-2A-4A	2	20M	1900	19100	16QAM	1	99	2	5M	1932.5	625	4	20M	2132.5	2175	13.26	13.36
		4	20M	1732.5	20175	16QAM	1	0	2	20M	1960	900	2	5M	1987.5	1175	14.59	14.73
	CA_2A-4A-4A	2	20M	1900	19100	16QAM	1	99	4	20M	2132.5	2175	4	5M	2152.5	2375	13.25	13.36
		4	20M	1732.5	20175	16QAM	1	0	4	5M	2152.5	2375	2	20M	1960	900	14.61	14.73
	CA_2A-2A-5A	2	20M	1900	19100	16QAM	1	99	2	5M	1932.5	625	5	10M	881.5	2525	13.29	13.36
		5	10M	844	20600	16QAM	1	0	2	20M	1960	900	2	5M	1987.5	1175	21.24	21.31
	CA_2A-2A-13A	2	20M	1900	19100	16QAM	1	99	2	5M	1932.5	625	13	10M	751	5230	13.23	13.36
		13	10M	782	23230	16QAM	1	0	2	20M	1960	900	2	5M	1987.5	1175	21.31	21.43
	CA_2A-46A-46A	2	20M	1900	19100	16QAM	1	99	46	20M	5540	50690	46	20M	5160	46890	13.31	13.36
	CA_2A-46C	2	20M	1900	19100	16QAM	1	99	46	20M	5540	50690	46	20M	5559.8	50888	13.28	13.36
	CA_2A-2A-66A	2	20M	1900	19100	16QAM	1	99	2	5M	1932.5	625	66	20M	2155	66886	13.28	13.36
		66	20M	1770	132572	16QAM	1	0	2	20M	1960	900	2	5M	1987.5	1175	14.52	14.60
	CA_2A-66A-66A	2	20M	1900	19100	16QAM	1	99	66	20M	2155	66886	66	5M	2197.5	67311	13.32	13.36
		66	20M	1770	132572	16QAM	1	0	66	5M	2112.5	66461	2	20M	1960	900	14.66	14.60
	CA_2A-66B	2	20M	1900	19100	16QAM	1	99	66	15M	2155	66886	66	5M	2164.3	66979	13.28	13.36
		66	15M	1745	132322	16QAM	1	0	66	5M	2145.7	66793	2	20M	1960	900	14.51	14.58
	CA_2A-66C	2	20M	1900	19100	16QAM	1	99	66	20M	2155	66886	66	20M	2174.8	67084	13.24	13.36
		66	20M	1770	132572	16QAM	1	0	66	20M	2170.2	67038	2	20M	1960	900	14.57	14.60
	CA_2A-4A-5A	2	20M	1900	19100	16QAM	1	99	4	20M	2132.5	2175	5	10M	881.5	2525	13.26	13.36
		4	20M	1732.5	20175	16QAM	1	0	5	10M	881.5	2525	2	20M	1960	900	14.69	14.73
		5	10M	844	20600	16QAM	1	0	2	20M	1960	900	4	20M	2132.5	2175	21.26	21.31
	CA_2A-4A-13A	2	20M	1900	19100	16QAM	1	99	4	20M	2132.5	2175	13	10M	751	5230	13.29	13.36
		4	20M	1732.5	20175	16QAM	1	0	13	10M	751	5230	2	20M	1960	900	14.65	14.73
		13	10M	782	23230	16QAM	1	0	2	20M	1960	900	4	20M	2132.5	2175	21.35	21.43
	CA_2A-5A-66A	2	20M	1900	19100	16QAM	1	99	5	10M	881.5	2525	66	20M	2155	66886	13.31	13.36
		5	10M	844	20600	16QAM	1	0	66	20M	2155	66886	2	20M	1960	900	21.26	21.31
		66	20M	1770	132572	16QAM	1	0	2	20M	1960	900	5	10M	881.5	2525	14.62	14.60
	CA_2A-13A-66A	2	20M	1900	19100	16QAM	1	99	13	10M	751	5230	66	20M	2155	66886	13.29	13.36
		13	10M	782	23230	16QAM	1	0	66	20M	2155	66886	2	20M	1960	900	21.40	21.43
		66	20M	1770	132572	16QAM	1	0	2	20M	1960	900	13	10M	751	5230	14.62	14.60
CA_4A-4A-5A	4	20M	1732.5	20175	16QAM	1	0	4	5M	2152.5	2375	5	10M	881.5	2525	14.68	14.73	
	5	10M	844	20600	16QAM	1	0	4	20M	2132.5	2175	4	5M	2152.5	2375	21.29	21.31	
CA_4A-4A-13A	4	20M	1732.5	20175	16QAM	1	0	4	5M	2152.5	2375	13	10M	751	5230	14.69	14.73	
	13	10M	782	23230	16QAM	1	0	4	20M	2132.5	2175	4	5M	2152.5	2375	21.36	21.43	
CA_4A-46A-46A	4	20M	1732.5	20175	16QAM	1	0	46	20M	5540	50690	46	20M	5160	46890	14.68	14.73	
CA_4A-46C	4	20M	1732.5	20175	16QAM	1	0	46	20M	5540	50690	46	20M	5559.8	50888	14.77	14.73	



Configure	CA Configuration (BCS)	PCC							SCC1				SCC2				Power		
		LTE Band	BW (MHz)	UL Freq. (MHz)	UL Channel	Mod.	UL# RB	UL RB Offset	LTE Band	BW (MHz)	DL Freq. (MHz)	DL Channel	LTE Band	BW (MHz)	DL Freq. (MHz)	DL Channel	With CA Tx. Power (dBm)	Without CA Tx. Power (dBm)	
Inter-Band	CA_5A-66A-66A	5	10M	844	20600	16QAM	1	0	66	20M	2155	66886	66	5M	2197.5	67311	21.29	21.31	
		66	20M	1770	132572	16QAM	1	0	66	5M	2112.5	66461	5	10M	881.5	2525	14.63	14.60	
	CA_5A-66B	5	10M	844	20600	16QAM	1	0	66	15M	2155	66886	66	5M	2164.3	66979	21.25	21.31	
		66	15M	1745	132322	16QAM	1	0	66	5M	2145.7	66793	5	10M	881.5	2525	14.62	14.58	
	CA_5A-66C	5	10M	844	20600	16QAM	1	0	66	20M	2155	66886	66	20M	2174.8	67084	21.24	21.31	
		66	20M	1770	132572	16QAM	1	0	66	20M	2170.2	67038	5	10M	881.5	2525	14.67	14.60	
	CA_13A-66A-66A	13	10M	782	23230	16QAM	1	0	66	20M	2155	66886	66	5M	2197.5	67311	21.37	21.43	
		66	20M	1770	132572	16QAM	1	0	66	5M	2112.5	66461	13	10M	751	5230	14.64	14.60	
	CA_13A-66B	13	10M	782	23230	16QAM	1	0	66	15M	2155	66886	66	5M	2164.3	66979	21.41	21.43	
		66	15M	1745	132322	16QAM	1	0	66	5M	2145.7	66793	13	10M	751	5230	14.56	14.58	
	CA_13A-66C	13	10M	782	23230	16QAM	1	0	66	20M	2155	66886	66	20M	2174.8	67084	21.42	21.43	
		66	20M	1770	132572	16QAM	1	0	66	20M	2170.2	67038	13	10M	751	5230	14.59	14.60	
	CA_66A-46C	66	20M	1770	132572	16QAM	1	0	46	20M	5540	50690	46	20M	5559.8	50888	14.58	14.60	
		66	20M	1770	132572	16QAM	1	0	66	5M	2112.5	66461	66	20M	2124.2	66578	14.61	14.60	
Intra-Band	Non-Contiguous	CA_66A-66C	66	20M	1770	132572	16QAM	1	0	66	20M	2170.2	67038	66	5M	2112.5	66461	14.67	14.60



**<Reduced Power Mode for P-Sensor On>**

**<Two Carrier power verification>**

Configure	CA Configuration (BCS)	PCC							SCC				Power	
		LTE Band	BW (MHz)	UL Freq. (MHz)	UL Channel	Mod.	UL# RB	UL RB Offset	LTE Band	BW (MHz)	DL Freq. (MHz)	DL Channel	With CA Tx. Power (dBm)	Without CA Tx. Power (dBm)
Inter-Band	CA_13A-46A	13	10M	782	23230	16QAM	1	0	46	20M	5540	50690	21.36	21.43
Intra-Band Contiguous	CA_5B	5	10M	844	20600	16QAM	1	0	5	10M	879.1	2501	21.28	21.31

**<Three Carrier power verification>**

Configure	CA Configuration (BCS)	PCC							SCC1				SCC2				Power	
		LTE Band	BW (MHz)	UL Freq. (MHz)	UL Channel	Mod.	UL# RB	UL RB Offset	LTE Band	BW (MHz)	DL Freq. (MHz)	DL Channel	LTE Band	BW (MHz)	DL Freq. (MHz)	DL Channel	With CA Tx. Power (dBm)	Without CA Tx. Power (dBm)
Inter-Band	CA_2A-2A-4A	2	20M	1900	19100	64QAM	1	49	2	5M	1932.5	625	4	20M	2132.5	2175	15.85	15.90
		4	20M	1720	20050	16QAM	1	0	2	20M	1960	900	2	5M	1987.5	1175	15.82	15.85
	CA_2A-4A-4A	2	20M	1900	19100	64QAM	1	49	4	20M	2132.5	2175	4	5M	2152.5	2375	15.82	15.90
		4	20M	1732.5	20175	16QAM	1	0	4	5M	2152.5	2375	2	20M	1960	900	15.81	15.85
	CA_2A-2A-5A	2	20M	1900	19100	64QAM	1	49	2	5M	1932.5	625	5	10M	881.5	2525	15.78	15.90
		5	10M	844	20600	16QAM	1	0	2	20M	1960	900	2	5M	1987.5	1175	21.2	21.31
	CA_2A-2A-13A	2	20M	1900	19100	64QAM	1	49	2	5M	1932.5	625	13	10M	751	5230	15.87	15.90
		13	10M	782	23230	16QAM	1	0	2	20M	1960	900	2	5M	1987.5	1175	21.31	21.43
	CA_2A-46A-46A	2	20M	1900	19100	64QAM	1	49	46	20M	5540	50690	46	20M	5160	46890	15.82	15.90
	CA_2A-46C	2	20M	1900	19100	64QAM	1	49	46	20M	5540	50690	46	20M	5559.8	50888	15.85	15.90
	CA_2A-2A-66A	2	20M	1900	19100	64QAM	1	49	2	5M	1932.5	625	66	20M	2155	66886	15.81	15.90
		66	20M	1720	132072	16QAM	1	0	2	20M	1960	900	2	5M	1987.5	1175	15.9	15.93
	CA_2A-66A-66A	2	20M	1900	19100	64QAM	1	49	66	20M	2155	66886	66	5M	2197.5	67311	15.81	15.90
		66	20M	1720	132072	16QAM	1	0	66	5M	2112.5	66461	2	20M	1960	900	15.87	15.93
	CA_2A-66B	2	20M	1900	19100	64QAM	1	49	66	15M	2155	66886	66	5M	2164.3	66979	15.85	15.90
		66	20M	1720	132072	16QAM	1	0	66	5M	2145.7	66793	2	20M	1960	900	15.78	15.93
	CA_2A-66C	2	20M	1900	19100	64QAM	1	49	66	20M	2155	66886	66	20M	2174.8	67084	15.81	15.90
		66	20M	1720	132072	16QAM	1	0	66	20M	2170.2	67038	2	20M	1960	900	15.91	15.93
	CA_2A-4A-5A	2	20M	1900	19100	64QAM	1	49	4	20M	2132.5	2175	5	10M	881.5	2525	15.87	15.90
		4	20M	1732.5	20175	16QAM	1	0	5	10M	881.5	2525	2	20M	1960	900	15.82	15.85
		5	10M	844	20600	16QAM	1	0	2	20M	1960	900	4	20M	2132.5	2175	21.26	21.31
	CA_2A-4A-13A	2	20M	1900	19100	64QAM	1	49	4	20M	2132.5	2175	13	10M	751	5230	15.87	15.90
		4	20M	1732.5	20175	16QAM	1	0	13	10M	751	5230	2	20M	1960	900	15.81	15.85
		13	10M	782	23230	16QAM	1	0	2	20M	1960	900	4	20M	2132.5	2175	21.35	21.43
	CA_2A-5A-66A	2	20M	1900	19100	64QAM	1	49	5	10M	881.5	2525	66	20M	2155	66886	15.87	15.90
		5	10M	844	20600	16QAM	1	0	66	20M	2155	66886	2	20M	1960	900	21.26	21.31
	CA_2A-13A-66A	66	20M	1720	132072	16QAM	1	0	2	20M	1960	900	5	10M	881.5	2525	15.91	15.93
		2	20M	1900	19100	64QAM	1	49	13	10M	751	5230	66	20M	2155	66886	15.86	15.90
	CA_2A-13A-66A	13	10M	782	23230	16QAM	1	0	66	20M	2155	66886	2	20M	1960	900	21.40	21.43
		66	20M	1720	132072	16QAM	1	0	2	20M	1960	900	13	10M	751	5230	15.87	15.93
CA_4A-4A-5A	4	20M	1732.5	20175	16QAM	1	0	4	5M	2152.5	2375	5	10M	881.5	2525	15.81	15.85	
	5	10M	844	20600	16QAM	1	0	4	20M	2132.5	2175	4	5M	2152.5	2375	21.29	21.31	
CA_4A-4A-13A	4	20M	1732.5	20175	16QAM	1	0	4	5M	2152.5	2375	13	10M	751	5230	15.82	15.85	
	13	10M	782	23230	16QAM	1	0	4	20M	2132.5	2175	4	5M	2152.5	2375	21.36	21.43	
CA_4A-46A-46A	4	20M	1732.5	20175	16QAM	1	0	46	20M	5540	50690	46	20M	5160	46890	15.82	15.85	
CA_4A-46C	4	20M	1732.5	20175	16QAM	1	0	46	20M	5540	50690	46	20M	5559.8	50888	15.83	15.85	



Configure	CA Configuration (BCS)	PCC							SCC1				SCC2				Power	
		LTE Band	BW (MHz)	UL Freq. (MHz)	UL Channel	Mod.	UL# RB	UL RB Offset	LTE Band	BW (MHz)	DL Freq. (MHz)	DL Channel	LTE Band	BW (MHz)	DL Freq. (MHz)	DL Channel	With CA Tx. Power (dBm)	Without CA Tx. Power (dBm)
Inter-Band	CA_5A-66A-66A	5	10M	844	20600	16QAM	1	0	66	20M	2155	66886	66	5M	2197.5	67311	21.29	21.31
		66	20M	1720	132072	16QAM	1	0	66	5M	2112.5	66461	5	10M	881.5	2525	15.91	15.93
	CA_5A-66B	5	10M	844	20600	16QAM	1	0	66	15M	2155	66886	66	5M	2164.3	66979	21.25	21.31
		66	20M	1720	132072	16QAM	1	0	66	5M	2145.7	66793	5	10M	881.5	2525	15.82	15.93
	CA_5A-66C	5	10M	844	20600	16QAM	1	0	66	20M	2155	66886	66	20M	2174.8	67084	21.24	21.31
		66	20M	1720	132072	16QAM	1	0	66	20M	2170.2	67038	5	10M	881.5	2525	15.87	15.93
	CA_13A-66A-66A	13	10M	782	23230	16QAM	1	0	66	20M	2155	66886	66	5M	2197.5	67311	21.37	21.43
		66	20M	1720	132072	16QAM	1	0	66	5M	2112.5	66461	13	10M	751	5230	15.88	15.93
	CA_13A-66B	13	10M	782	23230	16QAM	1	0	66	15M	2155	66886	66	5M	2164.3	66979	21.41	21.43
		66	20M	1720	132072	16QAM	1	0	66	5M	2145.7	66793	13	10M	751	5230	15.81	15.93
	CA_13A-66C	13	10M	782	23230	16QAM	1	0	66	20M	2155	66886	66	20M	2174.8	67084	21.42	21.43
		66	20M	1720	132072	16QAM	1	0	66	20M	2170.2	67038	13	10M	751	5230	14.59	14.60
	CA_66A-46C	66	20M	1720	132072	16QAM	1	0	46	20M	5540	50690	46	20M	5559.8	50888	15.78	15.93
		66	20M	1720	132072	16QAM	1	0	66	5M	2197.5	67311	66	20M	2124.2	66578	15.53	15.93
Intra-Band Non-Contiguous	CA_66A-66C	66	20M	1720	132072	16QAM	1	0	66	20M	2139.8	66734	66	5M	2112.5	66461	15.91	15.93
		66	20M	1720	132072	16QAM	1	0	66	20M	2139.8	66734	66	5M	2112.5	66461	15.91	15.93



<Reduced Power Mode for Handheld On>

<Two Carrier power verification>

Configure	CA Configuration (BCS)	PCC							SCC				Power	
		LTE Band	BW (MHz)	UL Freq. (MHz)	UL Channel	Mod.	UL# RB	UL RB Offset	LTE Band	BW (MHz)	DL Freq. (MHz)	DL Channel	With CA Tx. Power (dBm)	Without CA Tx. Power (dBm)
Inter-Band	CA_13A-46A	13	10M	782	23230	QPSK	1	0	46	20M	5540	50690	22.92	23.00
Intra-Band Contiguous	CA_5B	5	10M	844	20600	QPSK	1	25	5	10M	879.1	2501	23.28	23.30

<Three Carrier power verification>

Configure	CA Configuration (BCS)	PCC							SCC1				SCC2				Power	
		LTE Band	BW (MHz)	UL Freq. (MHz)	UL Channel	Mod.	UL# RB	UL RB Offset	LTE Band	BW (MHz)	DL Freq. (MHz)	DL Channel	LTE Band	BW (MHz)	DL Freq. (MHz)	DL Channel	With CA Tx. Power (dBm)	Without CA Tx. Power (dBm)
Inter-Band	CA_2A-2A-4A	2	20M	1900	19100	16QAM	1	0	2	5M	1932.5	625	4	20M	2132.5	2175	19.97	20.05
		4	20M	1720	20050	16QAM	1	0	2	20M	1960	900	2	5M	1987.5	1175	18.62	18.71
	CA_2A-4A-4A	2	20M	1900	19100	16QAM	1	0	4	20M	2132.5	2175	4	5M	2152.5	2375	19.92	20.05
		4	20M	1720	20050	16QAM	1	0	4	5M	2152.5	2375	2	20M	1960	900	18.63	18.71
	CA_2A-2A-5A	2	20M	1900	19100	16QAM	1	0	2	5M	1932.5	625	5	10M	881.5	2525	19.92	20.05
		5	10M	844	20600	QPSK	1	25	2	20M	1960	900	2	5M	1987.5	1175	23.16	23.30
	CA_2A-2A-13A	2	20M	1900	19100	16QAM	1	0	2	5M	1932.5	625	13	10M	751	5230	19.96	20.05
		13	10M	782	23230	QPSK	1	0	2	20M	1960	900	2	5M	1987.5	1175	23.18	23.00
	CA_2A-46A-46A	2	20M	1900	19100	16QAM	1	0	46	20M	5540	50690	46	20M	5160	46890	20.01	20.05
		2	20M	1900	19100	16QAM	1	0	46	20M	5540	50690	46	20M	5559.8	50888	20.03	20.05
	CA_2A-2A-66A	2	20M	1900	19100	16QAM	1	0	2	5M	1932.5	625	66	20M	2155	66886	19.94	20.05
		66	20M	1720	132072	16QAM	1	0	2	20M	1960	900	2	5M	1987.5	1175	18.46	18.58
	CA_2A-66A-66A	2	20M	1900	19100	16QAM	1	0	66	20M	2155	66886	66	5M	2197.5	67311	19.89	20.05
		66	20M	1720	132072	16QAM	1	0	66	5M	2197.5	67311	2	20M	1960	900	18.52	18.58
	CA_2A-66B	2	20M	1900	19100	16QAM	1	0	66	15M	2155	66886	66	5M	2164.3	66979	19.89	20.05
		66	15M	1772.5	132597	QPSK	1	0	66	5M	2145.7	66793	2	20M	1960	900	18.52	18.64
	CA_2A-66C	2	20M	1900	19100	16QAM	1	0	66	20M	2155	66886	66	20M	2174.8	67084	19.86	20.05
		66	20M	1720	132072	16QAM	1	0	66	20M	2139.8	66734	2	20M	1960	900	18.46	18.58
	CA_2A-4A-5A	2	20M	1900	19100	16QAM	1	0	4	20M	2132.5	2175	5	10M	881.5	2525	19.98	20.05
		4	20M	1720	20050	16QAM	1	0	5	10M	881.5	2525	2	20M	1960	900	18.65	18.71
		5	10M	844	20600	QPSK	1	25	2	20M	1960	900	4	20M	2132.5	2175	23.21	23.30
	CA_2A-4A-13A	2	20M	1900	19100	16QAM	1	0	4	20M	2132.5	2175	13	10M	751	5230	19.96	20.05
		4	20M	1720	20050	16QAM	1	0	13	10M	751	5230	2	20M	1960	900	18.67	18.71
		13	10M	782	23230	QPSK	1	0	2	20M	1960	900	4	20M	2132.5	2175	22.94	23.00
	CA_2A-5A-66A	2	20M	1900	19100	16QAM	1	0	5	10M	881.5	2525	66	20M	2155	66886	19.98	20.05
		5	10M	844	20600	QPSK	1	25	66	20M	2155	66886	2	20M	1960	900	23.26	23.30
		66	20M	1720	132072	16QAM	1	0	2	20M	1960	900	5	10M	881.5	2525	18.49	18.58
	CA_2A-13A-66A	2	20M	1900	19100	16QAM	1	0	13	10M	751	5230	66	20M	2155	66886	19.87	20.05
		13	10M	782	23230	QPSK	1	0	66	20M	2155	66886	2	20M	1960	900	22.95	23.00
		66	20M	1720	132072	16QAM	1	0	2	20M	1960	900	13	10M	751	5230	18.49	18.58
CA_4A-4A-5A	4	20M	1720	20050	16QAM	1	0	4	5M	2152.5	2375	5	10M	881.5	2525	18.56	18.71	
	5	10M	844	20600	QPSK	1	25	4	20M	2132.5	2175	4	5M	2152.5	2375	23.21	23.30	
CA_4A-4A-13A	4	20M	1720	20050	16QAM	1	0	4	5M	2152.5	2375	13	10M	751	5230	18.59	18.71	
	13	10M	782	23230	QPSK	1	0	4	20M	2132.5	2175	4	5M	2152.5	2375	22.94	23.00	
CA_4A-46A-46A	4	20M	1720	20050	16QAM	1	0	46	20M	5540	50690	46	20M	5160	46890	18.68	18.71	
CA_4A-46C	4	20M	1720	20050	16QAM	1	0	46	20M	5540	50690	46	20M	5559.8	50888	18.65	18.71	



Configure	CA Configuration (BCS)	PCC							SCC1				SCC2				Power		
		LTE Band	BW (MHz)	UL Freq. (MHz)	UL Channel	Mod.	UL# RB	UL RB Offset	LTE Band	BW (MHz)	DL Freq. (MHz)	DL Channel	LTE Band	BW (MHz)	DL Freq. (MHz)	DL Channel	With CA Tx. Power (dBm)	Without CA Tx. Power (dBm)	
Inter-Band	CA_5A-66A-66A	5	10M	844	20600	QPSK	1	25	66	20M	2155	66886	66	5M	2197.5	67311	23.21	23.30	
		66	20M	1720	132072	16QAM	1	0	66	5M	2197.5	67311	5	10M	881.5	2525	18.40	18.58	
	CA_5A-66B	5	10M	844	20600	QPSK	1	25	66	15M	2155	66886	66	5M	2164.3	66979	23.24	23.30	
		66	15M	1745	132322	16QAM	1	0	66	5M	2145.7	66793	5	10M	881.5	2525	18.46	18.64	
	CA_5A-66C	5	10M	844	20600	QPSK	1	25	66	20M	2155	66886	66	20M	2174.8	67084	23.09	23.30	
		66	20M	1720	132072	16QAM	1	0	66	20M	2139.8	66734	5	10M	881.5	2525	18.39	18.58	
	CA_13A-66A-66A	13	10M	782	23230	QPSK	1	0	66	20M	2155	66886	66	5M	2197.5	67311	22.95	23.00	
		66	20M	1720	132072	16QAM	1	0	66	5M	2197.5	67311	13	10M	751	5230	18.42	18.58	
	CA_13A-66B	13	10M	782	23230	QPSK	1	0	66	15M	2155	66886	66	5M	2164.3	66979	22.97	23.00	
		66	15M	1772.5	132597	QPSK	1	0	66	5M	2145.7	66793	13	10M	751	5230	18.67	18.64	
	CA_13A-66C	13	10M	782	23230	QPSK	1	0	66	20M	2155	66886	66	20M	2174.8	67084	22.95	23.00	
		66	20M	1720	132072	16QAM	1	0	66	20M	2139.8	66734	13	10M	751	5230	18.39	18.58	
	CA_66A-46C	66	20M	1720	132072	16QAM	1	0	46	20M	5540	50690	46	20M	5559.8	50888	18.46	18.58	
		66	20M	1720	132072	16QAM	1	0	66	5M	2197.5	67311	66	20M	2185.8	67194	18.46	18.58	
Intra-Band	Non-Contiguous	CA_66A-66C	66	20M	1720	132072	16QAM	1	0	66	20M	2139.8	66734	66	5M	2197.5	67311	18.49	18.58





<WLAN Conducted Power>

General Note:

1. Per KDB 248227 D01v02r02, SAR test reduction is determined according to 802.11 transmission mode configurations and certain exposure conditions with multiple test positions. In the 2.4 GHz band, separate SAR procedures are applied to DSSS and OFDM configurations to simplify DSSS test requirements. For OFDM, in both 2.4 and 5 GHz bands, an initial test configuration must be determined for each standalone and aggregated frequency band, according to the transmission mode configuration with the highest maximum output power specified for production units to perform SAR measurements. If the same highest maximum output power applies to different combinations of channel bandwidths, modulations and data rates, additional procedures are applied to determine which test configurations require SAR measurement. When applicable, an initial test position may be applied to reduce the number of SAR measurements required for next to the ear, UMPC mini-tablet or hotspot mode configurations with multiple test positions.
2. For 2.4 GHz 802.11b DSSS, either the initial test position procedure for multiple exposure test positions or the DSSS procedure for fixed exposure position is applied; these are mutually exclusive. For 2.4 GHz and 5 GHz OFDM configurations, the initial test configuration is applied to measure SAR using either the initial test position procedure for multiple exposure test position configurations or the initial test configuration procedures for fixed exposure test conditions. Based on the reported SAR of the measured configurations and maximum output power of the transmission mode configurations that are not included in the initial test configuration, the subsequent test configuration and initial test position procedures are applied to determine if SAR measurements are required for the remaining OFDM transmission configurations. In general, the number of test channels that require SAR measurement is minimized based on maximum output power measured for the test sample(s).
3. For OFDM transmission configurations in the 2.4 GHz and 5 GHz bands, When the same maximum power is specified for multiple transmission modes in a frequency band, the largest channel bandwidth, lowest order modulation, lowest data rate and lowest order 802.11a/g/n/ac mode is used for SAR measurement, on the highest measured output power channel for each frequency band.
4. DSSS and OFDM configurations are considered separately according to the required SAR procedures. SAR is measured in the initial test position using the 802.11 transmission mode configuration required by the DSSS procedure or initial test configuration and subsequent test configuration(s) according to the OFDM procedures. 18 The initial test position procedure is described in the following:
  - a. When the reported SAR of the initial test position is  $\leq 0.4$  W/kg, further SAR measurement is not required for the other test positions in that exposure configuration and 802.11 transmission mode combinations within the frequency band or aggregated band.
  - b. When the reported SAR of the test position is  $> 0.4$  W/kg, SAR is repeated for the 802.11 transmission mode configuration tested in the initial test position to measure the subsequent next closet/smallest test separation distance and maximum coupling test position on the highest maximum output power channel, until the report SAR is  $\leq 0.8$  W/kg or all required test position are tested.
  - c. For all positions/configurations, when the reported SAR is  $> 0.8$  W/kg, SAR is measured for these test positions/configurations on the subsequent next highest measured output power channel(s) until the reported SAR is  $\leq 1.2$  W/kg or all required channels are tested.

<2.4GHz WLAN>

	Mode	Channel	Frequency (MHz)	Average power (dBm)	Tune-Up Limit	Duty Cycle %
2.4GHz WLAN	802.11b 1Mbps	1	2412	14.56	15.00	100.00
		6	2437	16.68	17.00	
		11	2462	16.79	17.00	
	802.11g 6Mbps	1	2412	14.71	15.00	98.25
		6	2437	16.71	17.00	
		11	2462	15.34	17.00	
	802.11n-HT20 MCS0	1	2412	13.85	15.00	98.15
		6	2437	16.76	17.00	
		11	2462	15.53	17.00	

<5GHz WLAN>

5.2GHz WLAN	Mode	Channel	Frequency (MHz)	Average power (dBm)	Tune-Up Limit	Duty Cycle %
	802.11a 6Mbps	36	5180	17.21	17.50	98.28
		40	5200	17.26	17.50	
		44	5220	17.10	17.50	
		48	5240	17.05	17.50	
	802.11n-HT20 MCS0	36	5180	17.19	17.50	98.14
		40	5200	17.24	17.50	
		44	5220	17.11	17.50	
		48	5240	17.10	17.50	
	802.11n-HT40 MCS0	38	5190	15.34	16.00	96.33
46		5230	15.45	16.00		
802.11ac-VHT20 MCS0	36	5180	17.13	17.50	98.16	
	40	5200	17.15	17.50		
	44	5220	17.07	17.50		
	48	5240	16.97	17.50		
802.11ac-VHT40 MCS0	38	5190	15.33	16.00	96.35	
	46	5230	15.45	16.00		
802.11ac-VHT80 MCS0	42	5210	14.21	15.00	92.75	

5.3GHz WLAN	Mode	Channel	Frequency (MHz)	Average power (dBm)	Tune-Up Limit	Duty Cycle %
	802.11a 6Mbps	52	5260	17.03	17.50	98.28
		56	5280	17.21	17.50	
		60	5300	17.27	17.50	
		64	5320	17.23	17.50	
	802.11n-HT20 MCS0	52	5260	17.12	17.50	98.14
		56	5280	17.24	17.50	
		60	5300	17.26	17.50	
		64	5320	17.27	17.50	
	802.11n-HT40 MCS0	54	5270	15.23	16.00	96.33
		62	5310	15.44	16.00	
	802.11ac-VHT20 MCS0	52	5260	17.04	17.50	98.16
		56	5280	17.10	17.50	
		60	5300	17.15	17.50	
64		5320	17.23	17.50		
802.11ac-VHT40 MCS0	54	5270	15.19	16.00	96.35	
	62	5310	15.42	16.00		
802.11ac-VHT80 MCS0	58	5290	13.69	15.00	92.75	



5.5GHz WLAN	Mode	Channel	Frequency (MHz)	Average power (dBm)	Tune-Up Limit	Duty Cycle %
	802.11a 6Mbps	100	5500	17.07	17.50	98.28
		116	5580	17.18	17.50	
		124	5620	17.06	17.50	
		132	5660	16.81	17.50	
		140	5700	17.03	17.50	
		144	5720	16.90	17.50	
	802.11n-HT20 MCS0	100	5500	17.17	17.50	98.14
		116	5580	17.16	17.50	
		124	5620	17.13	17.50	
132		5660	16.87	17.50		
140		5700	16.67	17.50		
144		5720	16.94	17.50		
802.11n-HT40 MCS0	102	5510	15.42	16.00	96.33	
	110	5550	15.38	16.00		
	126	5630	15.39	16.00		
	134	5670	15.30	16.00		
	142	5710	15.41	16.00		
802.11ac-VHT20 MCS0	100	5500	17.12	17.50	98.16	
	116	5580	17.13	17.50		
	124	5620	17.20	17.50		
	132	5660	16.84	17.50		
	140	5700	17.14	17.50		
	144	5720	17.04	17.50		
802.11ac-VHT40 MCS0	102	5510	15.43	16.00	96.35	
	110	5550	15.37	16.00		
	126	5630	15.51	16.00		
	134	5670	15.38	16.00		
	142	5710	12.92	14.00		
802.11ac-VHT80 MCS0	106	5530	14.34	15.00	92.75	
	122	5610	14.18	15.00		
	138	5690	14.16	15.00		

5.8GHz WLAN	Mode	Channel	Frequency (MHz)	Average power (dBm)	Tune-Up Limit	Duty Cycle %
	802.11a 6Mbps	149	5745	16.86	17.50	98.28
		157	5785	16.89	17.50	
		165	5825	16.81	17.50	
	802.11n-HT20 MCS0	149	5745	16.87	17.50	98.14
		157	5785	16.96	17.50	
		165	5825	16.82	17.50	
	802.11n-HT40 MCS0	151	5755	15.34	16.00	96.33
		159	5795	15.44	16.00	
	802.11ac-VHT20 MCS0	149	5745	16.89	17.50	98.16
157		5785	17.08	17.50		
165		5825	16.83	17.50		
802.11ac-VHT40 MCS0	151	5755	15.29	16.00	96.35	
	159	5795	15.45	16.00		
802.11ac-VHT80 MCS0	155	5775	14.06	15.00	92.75	

<2.4GHz Bluetooth>

General Note:

1. For 2.4GHz Bluetooth SAR testing was selected 1Mbps, due to its highest average power.
2. The Bluetooth duty cycle is 77.02%as following figure, according to 2016 Oct. TCB workshop for Bluetooth SAR scaling need further consideration and the theoretical duty cycle is 83.3%, therefore the actual duty cycle will be scaled up to the theoretical value of Bluetooth reported SAR calculation

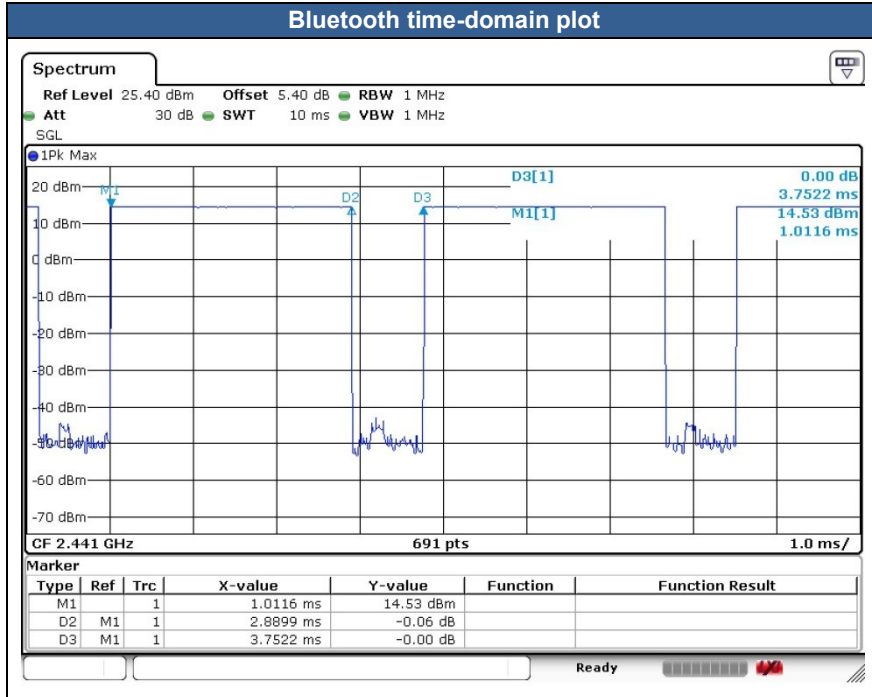

Mode	Channel	Frequency (MHz)	Average power (dBm)
			1Mbps
v3.0 with EDR	CH 00	2402	16.52
	CH 39	2441	14.81
	CH 78	2480	14.71
Tune-up Limit			16.60

Mode	Channel	Frequency (MHz)	Average power (dBm)
			GFSK
v4.2 with LE	CH 00	2402	5.01
	CH 19	2440	5.31
	CH 39	2480	4.80
Tune-up Limit			6.50

Mode	Channel	Frequency (MHz)	Average power (dBm)
			GFSK
v5.0 with LE	CH 00	2402	4.88
	CH 19	2440	5.14
	CH 39	2480	4.77
Tune-up Limit			6.50

### 14. Antenna Location

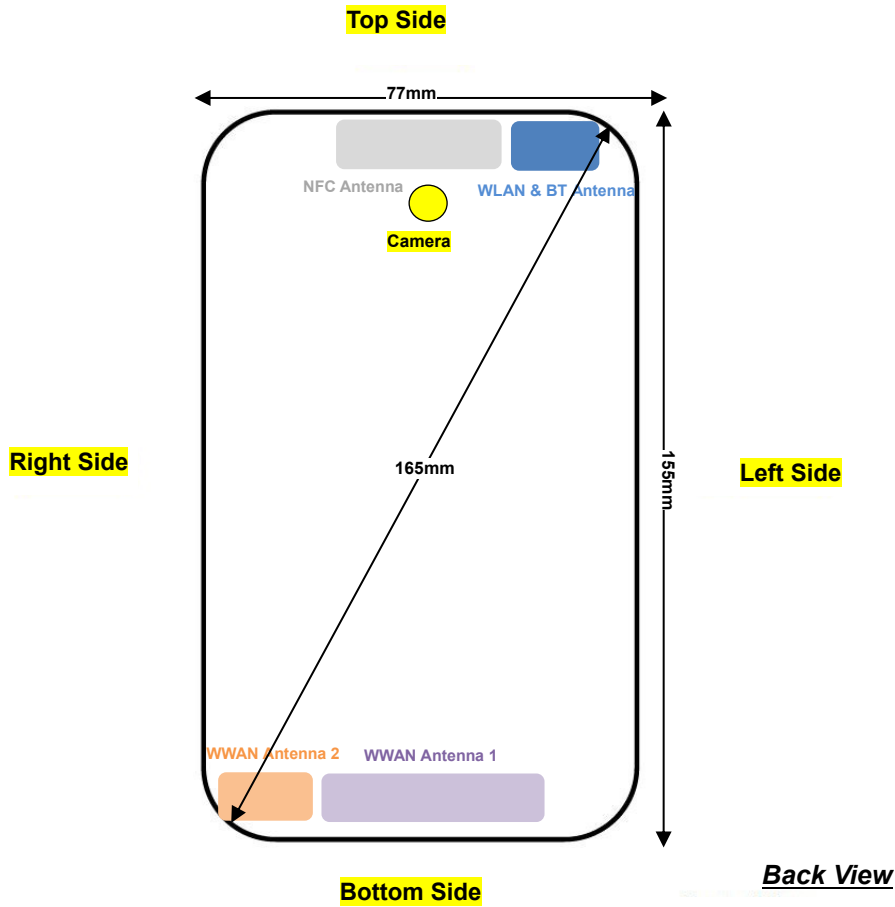

Antenna	Support Band
WWAN Antenna 1	GSM: 850 / 1900 WCDMA: B2 / B5 CDMA: BC0 / BC1 LTE: B2 / B4 / B5 / B13 / B66
WWAN Antenna 2	LTE: B7
WLAN & BT Antenna	WLAN 2.4GHz WLAN 5GHz Bluetooth
NFC Antenna	NFC

Distance of the Antenna to the EUT surface/edge						
Antennas	Back	Front	Top Side	Bottom Side	Right Side	Left Side
WWAN Antenna 1	≤ 25mm	≤ 25mm	>25mm	≤ 25mm	≤ 25mm	≤ 25mm
WWAN Antenna 2	≤ 25mm	≤ 25mm	>25mm	≤ 25mm	≤ 25mm	>25mm
WLAN & BT	≤ 25mm	≤ 25mm	≤ 25mm	>25mm	>25mm	≤ 25mm

Positions for SAR tests; Hotspot mode						
Antennas	Back	Front	Top Side	Bottom Side	Right Side	Left Side
WWAN Antenna 1	Yes	Yes	No	Yes	Yes	Yes
WWAN Antenna 2	Yes	Yes	No	Yes	Yes	No
WLAN & BT	Yes	Yes	Yes	No	No	Yes

**General Note:** Referring to KDB 941225 D06 v02r01, when the overall device length and width are ≥ 9cm\*5cm, the test distance is 10 mm. SAR must be measured for all sides and surfaces with a transmitting antenna located within 25mm from that surface or edge.



## **15. SAR Test Results**

### **General Note:**

1. Per KDB 447498 D01v06, the reported SAR is the measured SAR value adjusted for maximum tune-up tolerance.
  - a. Tune-up scaling Factor = tune-up limit power (mW) / EUT RF power (mW), where tune-up limit is the maximum rated power among all production units.
  - b. For SAR testing of WLAN signal with non-100% duty cycle, the measured SAR is scaled-up by the duty cycle scaling factor which is equal to "1/(duty cycle)"
  - c. For WWAN: Reported SAR(W/kg)= Measured SAR(W/kg)\*Tune-up Scaling Factor
  - d. For WLAN/Bluetooth: Reported SAR(W/kg)= Measured SAR(W/kg)\* Duty Cycle scaling factor \* Tune-up scaling factor
2. Per KDB 447498 D01v06, for each exposure position, testing of other required channels within the operating mode of a frequency band is not required when the *reported* 1-g or 10-g SAR for the mid-band or highest output power channel is:
  - $\leq 0.8$  W/kg or 2.0 W/kg, for 1-g or 10-g respectively, when the transmission band is  $\leq 100$  MHz
  - $\leq 0.6$  W/kg or 1.5 W/kg, for 1-g or 10-g respectively, when the transmission band is between 100 MHz and 200 MHz
  - $\leq 0.4$  W/kg or 1.0 W/kg, for 1-g or 10-g respectively, when the transmission band is  $\geq 200$  MHz
3. Per KDB 865664 D01v01r04, for each frequency band, repeated SAR measurement is required when the measured SAR is  $\geq 0.8$ W/kg. Per KDB 865664 D01v01r04, if the extremity repeated SAR is necessary, the same procedures should be adapted for measurements according to extremity and occupational exposure limits by applying a factor of 2.5 for extremity exposure and a factor of 5 for occupational exposure to the corresponding SAR thresholds.
4. Per KDB 648474 D04v01r03, when the reported SAR for a body-worn accessory measured without a headset connected to the handset is  $\leq 1.2$  W/kg, SAR testing with a headset connected to the handset is not required.
5. This device has two WWAN transmitter antennas. More details of the antennas can refer to antenna location chapter. WWAN antenna 1 frequency bands include GSM850/1900, WCDMA B2 / B5, CDMA BC0 / BC1 and LTE B2 / B4 / B5 / B13 / B66, WWAN antenna 2 frequency bands only includes LTE B7.
6. The device employs proximity sensors that detect the presence of the user's body at the front or back faces of the device. When front or back body worn condition is detected, GSM850/1900, WCDMA B2 / B5, CDMA BC0 / BC1 and LTE B2 / B4 / B5 / B7 / B13 / B66 reduced power will be active. (P-sensor can't work at detecting presence of the user's body at the four edges of the device.)
7. When hotspot mode is enabled, power reduction will be activated to limit the maximum power of GSM850/1900, WCDMA B2 / B5, CDMA BC0 / BC1 and LTE B2 / B4 / B5 / B7 / B13 / B66.
8. For GSM850/1900, WCDMA B5, CDMA BC0 and LTE B5 / B7 / B13, this device hotspot reduced power and P-sensor reduced power level are the same. So only show one reduced power level for hotspot reduced power and P-sensor reduced power for this application.
9. The device additionally employs proximity sensors that detect the presence of tissue near the currently active transmit antenna, the handheld reduced power table which at GSM1900, WCDMA B2, CDMA BC1 and LTE band LTE B2 / B4 / B7 / B66 reduced powers will be active.
10. Per KDB648474 D04v01r03, for smart phones with a display diagonal dimension  $> 15.0$  cm or an overall diagonal dimension  $> 16.0$  cm, when hotspot mode applies, 10-g extremity SAR is required only for the surfaces and edges with hotspot mode 1-g reported SAR  $> 1.2$  W/kg, however, when power reduction applies to hotspot mode the measured SAR must be scaled to the maximum output power, including tolerance, allowed for phablet modes to compare with the 1.2 W/kg SAR test reduction threshold.
  - a. For this device for WWAN transmitter scaled to handheld power or full power mode for product specific 10g SAR is higher than 1.2W/kg of GSM850/1900, WCDMA B2 / B5, CDMA BC0 / BC1 and LTE B2 / B4 / B5 / B7 / B13 / B66, therefore product specific SAR is necessary.
  - b. WLAN 5.3/5.5GHz tested the product specific 10g SAR since it has no hotspot mode.
  - c. When 10-g product specific 10g SAR is considered, SAR thresholds is specified in the procedures for SAR test reduction and exclusion should be multiplied by 2.5.

**GSM Note:**

1. Per KDB 941225 D01v03r01, for SAR test reduction for GSM / GPRS / EDGE modes is determined by the source-based time-averaged output power including tune-up tolerance. The mode with highest specified time-averaged output power should be tested for SAR compliance in the applicable exposure conditions. For modes with the same specified maximum output power and tolerance, the higher number time-slot configuration should be tested. Therefore, the GPRS (3Tx slots) for GSM850/GSM1900 is considered as the primary mode.
2. Other configurations of GSM / GPRS / EDGE are considered as secondary modes. The 3G SAR test reduction procedure is applied, when the maximum output power and tune-up tolerance specified for production units in a secondary mode is  $\leq \frac{1}{4}$  dB higher than the primary mode, SAR measurement is not required for the secondary mode.
3. Power reduction which is triggered by hotspot/P-Sensor is implemented in GSM850 band. For hotspot/P-Sensor mode SAR testing, GPRS 3Tx slots were set in reduced power due to its highest frame-average power.
4. Power reduction which is triggered by hotspot/P-Sensor/handheld mode is implemented in GSM1900 band. For hotspot mode SAR testing, GPRS 4Tx slots was set in reduced power due to its highest frame-average power, and for P-Sensor/handheld mode SAR testing, GPRS 3Tx slots was set in reduced power due to its highest frame-average power.
5. For GSM1900, only GSM mode supports antenna tuning technique, consider antenna matching optimal performance, so we chose GSM 1Tx slot to verify the worst case of head and body-worn SAR testing.

**WCDMA Note:**

1. Per KDB 941225 D01v03r01, for SAR testing is measured using a 12.2 kbps RMC with TPC bits configured to all "1's".
2. Per KDB 941225 D01v03r01, RMC 12.2kbps setting is used to evaluate SAR. The maximum output power and tune-up tolerance specified for production units in HSDPA / HSUPA / DC-HSDPA is  $\leq \frac{1}{4}$  dB higher than RMC 12.2Kbps or when the highest reported SAR of the RMC12.2Kbps is scaled by the ratio of specified maximum output power and tune-up tolerance of HSDPA / HSUPA / DC-HSDPA to RMC12.2Kbps and the adjusted SAR is  $\leq 1.2$  W/kg, SAR measurement is not required for HSDPA / HSUPA / DC-HSDPA, and according to the following RF output power, the output power results of the secondary modes (HSUPA, HSDPA, DC-HSDPA) are less than  $\frac{1}{4}$  dB higher than the primary modes; therefore, SAR measurement is not required for HSDPA / HSUPA / DC-HSDPA.

**CDMA Note:**

1. Per KDB 941225 D01v03r01, SAR for next to the ear head exposure is measured in RC3 with the handset configured to transmit at full rate in SO55.
2. Per KDB 941225 D01v03r01, in Hotspot mode EUT is treated as data device and SAR is tested with Ev-Do Rev 0 (RTAP 153.6kbps) as the primary mode.
3. Per KDB 941225 D01v03r01, for Body-worn accessory SAR is measured in RC3 with the handset configured in TDSO/SO32 to transmit at full rate on FCH only with all other code channels disabled. The body-worn accessory procedures in KDB Publication 447498 are applied. The 3G SAR test reduction procedure is applied to the multiple code channel configuration (FCH+SCH), with FCH only as the primary mode.

**LTE Note:**

1. Per KDB 941225 D05v02r05, start with the largest channel bandwidth and measure SAR for QPSK with 1 RB allocation, using the RB offset and required test channel combination with the highest maximum output power for RB offsets at the upper edge, middle and lower edge of each required test channel.
2. Per KDB 941225 D05v02r05, 50% RB allocation for QPSK SAR testing follows 1RB QPSK allocation procedure.
3. Per KDB 941225 D05v02r05, for QPSK with 100% RB allocation, SAR is not required when the highest maximum output power for 100 % RB allocation is less than the highest maximum output power in 50% and 1 RB allocations and the highest reported SAR for 1 RB and 50% RB allocation are  $\leq 0.8$  W/kg. Otherwise, SAR is measured for the highest output power channel; and if the reported SAR is  $> 1.45$  W/kg, the remaining required test channels must also be tested.
4. Per KDB 941225 D05v02r05, 16QAM/64QAM output power for each RB allocation configuration is  $>$  not  $\frac{1}{2}$  dB higher than the same configuration in QPSK and the reported SAR for the QPSK configuration is  $\leq 1.45$  W/kg; Per KDB 941225 D05v02r05, 16QAM/64QAM SAR testing is not required.
5. Per KDB 941225 D05v02r05, smaller bandwidth output power for each RB allocation configuration is  $>$  not  $\frac{1}{2}$  dB higher than the same configuration in the largest supported bandwidth, and the reported SAR for the largest supported bandwidth is  $\leq 1.45$  W/kg; Per KDB 941225 D05v02r05, smaller bandwidth SAR testing is not required.
6. For LTE B4 / B5 the maximum bandwidth does not support three non-overlapping channels, per KDB 941225 D05v02r05, when a device supports overlapping channel assignment in a channel bandwidth configuration, the middle channel of the group of overlapping channels should be selected for testing.
7. LTE B4 SAR test was covered by B66; according to April 2015 TCB workshop, SAR test for overlapping LTE bands can be reduced if
  - c. the maximum output power, including tolerance, for the smaller band is  $\leq$  the larger band to qualify for the SAR test exclusion
  - d. the channel bandwidth and other operating parameters for the smaller band are fully supported by the larger band

**WLAN Note:**

1. Per KDB 248227 D01v02r02, for 2.4GHz 802.11g/n SAR testing is not required when the highest reported SAR for DSSS is adjusted by the ratio of OFDM to DSSS specified maximum output power and the adjusted SAR is  $\leq 1.2$  W/kg.
2. Per KDB 248227 D01v02r02, U-NII-1 SAR testing is not required when the U-NII-2A band highest reported SAR for a test configuration is  $\leq 1.2$  W/kg, SAR is not required for U-NII-1 band.
3. When the reported SAR of the test position is  $> 0.4$  W/kg, SAR is repeated for the 802.11 transmission mode configuration tested in the initial test position to measure the subsequent next closet/smallest test separation distance and maximum coupling test position on the highest maximum output power channel, until the report SAR is  $\leq 0.8$  W/kg or all required test position are tested.
4. For all positions / configurations, when the reported SAR is  $> 0.8$  W/kg, SAR is measured for these test positions / configurations on the subsequent next highest measured output power channel(s) until the reported SAR is  $\leq 1.2$  W/kg or all required channels are tested.
5. During SAR testing the WLAN transmission was verified using a spectrum analyzer.



**15.1 Head SAR**

**<GSM SAR>**

Plot No.	Band	Mode	Test Position	Power Mode	Ch.	Freq. (MHz)	Average Power (dBm)	Tune-Up Limit (dBm)	Tune-up Scaling Factor	Power Drift (dB)	Measured 1g SAR (W/kg)	Reported 1g SAR (W/kg)
	GSM850	GPRS 3 Tx slots	Right Cheek	Full	251	848.8	30.31	31.00	1.172	0.02	0.181	0.212
	GSM850	GPRS 3 Tx slots	Right Tilted	Full	251	848.8	30.31	31.00	1.172	0.12	0.127	0.149
01	GSM850	GPRS 3 Tx slots	Left Cheek	Full	251	848.8	30.31	31.00	1.172	0.03	0.225	<b>0.264</b>
	GSM850	GPRS 3 Tx slots	Left Tilted	Full	251	848.8	30.31	31.00	1.172	0.07	0.125	0.147
02	GSM1900	GPRS 3 Tx slots	Right Cheek	Full	810	1909.8	26.87	28.00	1.297	0.06	0.120	<b>0.156</b>
	GSM1900	GPRS 3 Tx slots	Right Tilted	Full	810	1909.8	26.87	28.00	1.297	-0.08	0.043	0.056
	GSM1900	GPRS 3 Tx slots	Left Cheek	Full	810	1909.8	26.87	28.00	1.297	0.04	0.103	0.134
	GSM1900	GPRS 3 Tx slots	Left Tilted	Full	810	1909.8	26.87	28.00	1.297	0.07	0.074	0.096
	GSM1900	GSM 1 Tx slot	Right Cheek	Full	810	1909.8	29.99	30.50	1.125	0.03	0.092	0.103

**<WCDMA SAR>**

Plot No.	Band	Mode	Test Position	Power Mode	Ch.	Freq. (MHz)	Average Power (dBm)	Tune-Up Limit (dBm)	Tune-up Scaling Factor	Power Drift (dB)	Measured 1g SAR (W/kg)	Reported 1g SAR (W/kg)
	WCDMA Band V	RMC 12.2Kbps	Right Cheek	Full	4182	836.4	23.30	24.00	1.175	0.02	0.211	0.248
	WCDMA Band V	RMC 12.2Kbps	Right Tilted	Full	4182	836.4	23.30	24.00	1.175	0.05	0.151	0.177
03	WCDMA Band V	RMC 12.2Kbps	Left Cheek	Full	4182	836.4	23.30	24.00	1.175	0.05	0.290	<b>0.341</b>
	WCDMA Band V	RMC 12.2Kbps	Left Tilted	Full	4182	836.4	23.30	24.00	1.175	-0.08	0.160	0.188
04	WCDMA Band II	RMC 12.2Kbps	Right Cheek	Full	9538	1907.6	23.52	24.00	1.117	0.01	0.218	<b>0.243</b>
	WCDMA Band II	RMC 12.2Kbps	Right Tilted	Full	9538	1907.6	23.52	24.00	1.117	-0.05	0.086	0.096
	WCDMA Band II	RMC 12.2Kbps	Left Cheek	Full	9538	1907.6	23.52	24.00	1.117	0.03	0.197	0.220
	WCDMA Band II	RMC 12.2Kbps	Left Tilted	Full	9538	1907.6	23.52	24.00	1.117	0.1	0.142	0.159

**<CDMA2000 SAR>**

Plot No.	Band	Mode	Test Position	Power Mode	Ch.	Freq. (MHz)	Average Power (dBm)	Tune-Up Limit (dBm)	Tune-up Scaling Factor	Power Drift (dB)	Measured 1g SAR (W/kg)	Reported 1g SAR (W/kg)
	CDMA2000 BC0	RC3 SO55	Right Cheek	Full	777	848.31	24.15	25.00	1.216	0.02	0.291	0.354
	CDMA2000 BC0	RC3 SO55	Right Tilted	Full	777	848.31	24.15	25.00	1.216	0.11	0.155	0.189
05	CDMA2000 BC0	RC3 SO55	Left Cheek	Full	777	848.31	24.15	25.00	1.216	0.04	0.386	<b>0.469</b>
	CDMA2000 BC0	RC3 SO55	Left Tilted	Full	777	848.31	24.15	25.00	1.216	0.02	0.168	0.204
06	CDMA2000 BC1	RC3 SO55	Right Cheek	Full	1175	1908.75	23.91	25.00	1.285	0.04	0.225	<b>0.289</b>
	CDMA2000 BC1	RC3 SO55	Right Tilted	Full	1175	1908.75	23.91	25.00	1.285	-0.05	0.085	0.109
	CDMA2000 BC1	RC3 SO55	Left Cheek	Full	1175	1908.75	23.91	25.00	1.285	0.18	0.169	0.217
	CDMA2000 BC1	RC3 SO55	Left Tilted	Full	1175	1908.75	23.91	25.00	1.285	0.12	0.132	0.170



<LTE SAR>

Plot No.	Band	BW (MHz)	Modulation	RB Size	RB Offset	Test Position	Power Mode	Ch.	Freq. (MHz)	Average Power (dBm)	Tune-Up Limit (dBm)	Tune-up Scaling Factor	Power Drift (dB)	Measured 1g SAR (W/kg)	Reported 1g SAR (W/kg)
	LTE Band 13	10M	QPSK	1	0	Right Cheek	Full	23230	782	23.00	24.00	1.259	0.06	0.180	0.227
	LTE Band 13	10M	QPSK	25	0	Right Cheek	Full	23230	782	21.92	23.00	1.282	0.02	0.103	0.132
	LTE Band 13	10M	QPSK	1	0	Right Tilted	Full	23230	782	23.00	24.00	1.259	0.1	0.105	0.132
	LTE Band 13	10M	QPSK	25	0	Right Tilted	Full	23230	782	21.92	23.00	1.282	0.03	0.058	0.074
07	LTE Band 13	10M	QPSK	1	0	Left Cheek	Full	23230	782	23.00	24.00	1.259	0.02	0.208	<b>0.262</b>
	LTE Band 13	10M	QPSK	25	0	Left Cheek	Full	23230	782	21.92	23.00	1.282	0.05	0.117	0.150
	LTE Band 13	10M	QPSK	1	0	Left Tilted	Full	23230	782	23.00	24.00	1.259	-0.09	0.108	0.136
	LTE Band 13	10M	QPSK	25	0	Left Tilted	Full	23230	782	21.92	23.00	1.282	-0.08	0.059	0.076
	LTE Band 5	10M	QPSK	1	25	Right Cheek	Full	20525	836.5	23.00	24.00	1.259	0.05	0.209	0.263
	LTE Band 5	10M	QPSK	25	25	Right Cheek	Full	20525	836.5	21.92	23.00	1.282	0.03	0.112	0.144
	LTE Band 5	10M	QPSK	1	25	Right Tilted	Full	20525	836.5	23.00	24.00	1.259	0.06	0.107	0.135
	LTE Band 5	10M	QPSK	25	25	Right Tilted	Full	20525	836.5	21.92	23.00	1.282	0.01	0.059	0.076
08	LTE Band 5	10M	QPSK	1	25	Left Cheek	Full	20525	836.5	23.00	24.00	1.259	0.03	0.259	<b>0.326</b>
	LTE Band 5	10M	QPSK	25	25	Left Cheek	Full	20525	836.5	21.92	23.00	1.282	0.06	0.141	0.181
	LTE Band 5	10M	QPSK	1	25	Left Tilted	Full	20525	836.5	23.00	24.00	1.259	-0.07	0.126	0.159
	LTE Band 5	10M	QPSK	25	25	Left Tilted	Full	20525	836.5	21.92	23.00	1.282	-0.16	0.065	0.083
09	LTE Band 66	20M	QPSK	1	0	Right Cheek	Full	132572	1770	23.10	24.00	1.230	0.07	0.463	<b>0.570</b>
	LTE Band 66	20M	QPSK	50	0	Right Cheek	Full	132572	1770	22.03	23.00	1.250	0.02	0.226	0.283
	LTE Band 66	20M	QPSK	1	0	Right Tilted	Full	132572	1770	23.10	24.00	1.230	0.01	0.142	0.175
	LTE Band 66	20M	QPSK	50	0	Right Tilted	Full	132572	1770	22.03	23.00	1.250	0.04	0.076	0.095
	LTE Band 66	20M	QPSK	1	0	Left Cheek	Full	132572	1770	23.10	24.00	1.230	-0.01	0.283	0.348
	LTE Band 66	20M	QPSK	50	0	Left Cheek	Full	132572	1770	22.03	23.00	1.250	0.14	0.123	0.154
	LTE Band 66	20M	QPSK	1	0	Left Tilted	Full	132572	1770	23.10	24.00	1.230	0.05	0.176	0.217
	LTE Band 66	20M	QPSK	50	0	Left Tilted	Full	132572	1770	22.03	23.00	1.250	0.13	0.095	0.119
10	LTE Band 2	20M	QPSK	1	0	Right Cheek	Full	19100	1900	23.33	24.00	1.167	0.03	0.271	<b>0.316</b>
	LTE Band 2	20M	QPSK	50	0	Right Cheek	Full	19100	1900	22.38	23.00	1.153	0.02	0.145	0.167
	LTE Band 2	20M	QPSK	1	0	Right Tilted	Full	19100	1900	23.33	24.00	1.167	0.03	0.098	0.114
	LTE Band 2	20M	QPSK	50	0	Right Tilted	Full	19100	1900	22.38	23.00	1.153	0.01	0.051	0.059
	LTE Band 2	20M	QPSK	1	0	Left Cheek	Full	19100	1900	23.33	24.00	1.167	0.1	0.219	0.256
	LTE Band 2	20M	QPSK	50	0	Left Cheek	Full	19100	1900	22.38	23.00	1.153	0.02	0.089	0.103
	LTE Band 2	20M	QPSK	1	0	Left Tilted	Full	19100	1900	23.33	24.00	1.167	0.15	0.173	0.202
	LTE Band 2	20M	QPSK	50	0	Left Tilted	Full	19100	1900	22.38	23.00	1.153	0.02	0.091	0.105
11	LTE Band 7	20M	QPSK	1	0	Right Cheek	Full	20850	2510	22.95	24.00	1.274	0.09	0.619	<b>0.788</b>
	LTE Band 7	20M	QPSK	50	0	Right Cheek	Full	20850	2510	21.89	23.00	1.291	-0.12	0.344	0.444
	LTE Band 7	20M	QPSK	1	0	Right Tilted	Full	20850	2510	22.95	24.00	1.274	0.12	0.235	0.299
	LTE Band 7	20M	QPSK	50	0	Right Tilted	Full	20850	2510	21.89	23.00	1.291	0.12	0.124	0.160
	LTE Band 7	20M	QPSK	1	0	Left Cheek	Full	20850	2510	22.95	24.00	1.274	0.02	0.335	0.427
	LTE Band 7	20M	QPSK	50	0	Left Cheek	Full	20850	2510	21.89	23.00	1.291	0.09	0.179	0.231
	LTE Band 7	20M	QPSK	1	0	Left Tilted	Full	20850	2510	22.95	24.00	1.274	-0.02	0.240	0.306
	LTE Band 7	20M	QPSK	50	0	Left Tilted	Full	20850	2510	21.89	23.00	1.291	-0.04	0.123	0.159



**<WLAN 2.4GHz SAR>**

Plot No.	Band	Mode	Test Position	Ch.	Freq. (MHz)	Average Power (dBm)	Tune-Up Limit (dBm)	Tune-up Scaling Factor	Duty Cycle %	Duty Cycle Scaling Factor	Power Drift (dB)	Max Area Scan SAR	Measured 1g SAR (W/kg)	Reported 1g SAR (W/kg)
12	WLAN2.4GHz	802.11b 1Mbps	Right Cheek	11	2462	16.79	17.00	1.050	100	1.000	0.19	0.889	0.447	<b>0.469</b>
	WLAN2.4GHz	802.11b 1Mbps	Right Tilted	11	2462	16.79	17.00	1.050	100	1.000	0.05	0.470	0.292	0.306
	WLAN2.4GHz	802.11b 1Mbps	Left Cheek	11	2462	16.79	17.00	1.050	100	1.000		0.157		
	WLAN2.4GHz	802.11b 1Mbps	Left Tilted	11	2462	16.79	17.00	1.050	100	1.000		0.169		

**<WLAN 5GHz SAR>**

Plot No.	Band	Mode	Test Position	Ch.	Freq. (MHz)	Average Power (dBm)	Tune-Up Limit (dBm)	Tune-up Scaling Factor	Duty Cycle %	Duty Cycle Scaling Factor	Power Drift (dB)	Max Area Scan SAR	Measured 1g SAR (W/kg)	Reported 1g SAR (W/kg)
	WLAN5.3GHz	802.11a 6Mbps	Right Cheek	60	5300	17.27	17.50	1.054	98.28	1.018	0.01	2.377	0.952	1.022
13	WLAN5.3GHz	802.11a 6Mbps	Right Cheek	64	5320	17.23	17.50	1.064	98.28	1.018	-0.02		1.020	<b>1.105</b>
	WLAN5.3GHz	802.11a 6Mbps	Right Tilted	60	5300	17.27	17.50	1.054	98.28	1.018	0.05	1.824	0.629	0.675
	WLAN5.3GHz	802.11a 6Mbps	Left Cheek	60	5300	17.27	17.50	1.054	98.28	1.018		0.523		
	WLAN5.3GHz	802.11a 6Mbps	Left Tilted	60	5300	17.27	17.50	1.054	98.28	1.018		0.402		
	WLAN5.5GHz	802.11a 6Mbps	Right Cheek	116	5580	17.18	17.50	1.076	98.28	1.018	0.13	2.629	0.998	1.094
14	WLAN5.5GHz	802.11a 6Mbps	Right Cheek	100	5500	17.07	17.50	1.104	98.28	1.018	-0.02		0.990	<b>1.113</b>
	WLAN5.5GHz	802.11a 6Mbps	Right Tilted	116	5580	17.18	17.50	1.076	98.28	1.018	0.09	1.684	0.534	0.585
	WLAN5.5GHz	802.11a 6Mbps	Left Cheek	116	5580	17.18	17.50	1.076	98.28	1.018		0.524		
	WLAN5.5GHz	802.11a 6Mbps	Left Tilted	116	5580	17.18	17.50	1.076	98.28	1.018		0.478		
15	WLAN 5.8GHz	802.11a 6Mbps	Right Cheek	157	5785	16.89	17.50	1.151	98.28	1.018	0.02	1.613	0.561	<b>0.657</b>
	WLAN 5.8GHz	802.11a 6Mbps	Right Tilted	157	5785	16.89	17.50	1.151	98.28	1.018	0.05	1.451	0.461	0.540
	WLAN 5.8GHz	802.11a 6Mbps	Left Cheek	157	5785	16.89	17.50	1.151	98.28	1.018		0.595		
	WLAN 5.8GHz	802.11a 6Mbps	Left Tilted	157	5785	16.89	17.50	1.151	98.28	1.018		0.603		

**<Bluetooth SAR>**

Plot No.	Band	Mode	Test Position	Ch.	Freq. (MHz)	Average Power (dBm)	Tune-Up Limit (dBm)	Tune-up Scaling Factor	Duty Cycle %	Duty Cycle Scaling Factor	Power Drift (dB)	Measured 1g SAR (W/kg)	Reported 1g SAR (W/kg)
16	Bluetooth	1Mbps	Right Cheek	0	2402	16.52	16.60	1.019	77.02	1.082	0.07	0.397	<b>0.438</b>
	Bluetooth	1Mbps	Right Tilted	0	2402	16.52	16.60	1.019	77.02	1.082	0.08	0.336	0.370
	Bluetooth	1Mbps	Left Cheek	0	2402	16.52	16.60	1.019	77.02	1.082	0.12	0.150	0.165
	Bluetooth	1Mbps	Left Tilted	0	2402	16.52	16.60	1.019	77.02	1.082	0.03	0.138	0.152



**15.2 Hotspot SAR**

**<GSM SAR>**

Plot No.	Band	Mode	Test Position	Gap (mm)	Power Mode	Ch.	Freq. (MHz)	Average Power (dBm)	Tune-Up Limit (dBm)	Tune-up Scaling Factor	Power Drift (dB)	Measured 1g SAR (W/kg)	Reported 1g SAR (W/kg)
	GSM850	GPRS 3 Tx slots	Front	5	Hotspot On	251	848.8	28.30	29.50	1.318	0.14	0.504	0.664
17	GSM850	GPRS 3 Tx slots	Back	5	Hotspot On	251	848.8	28.30	29.50	1.318	0.19	0.695	<b>0.916</b>
	GSM850	GPRS 3 Tx slots	Back	5	Hotspot On	128	824.2	27.95	29.50	1.429	0.03	0.631	0.902
	GSM850	GPRS 3 Tx slots	Back	5	Hotspot On	189	836.4	28.23	29.50	1.340	0.08	0.625	0.837
	GSM850	GPRS 3 Tx slots	Left Side	5	Hotspot On	251	848.8	28.30	29.50	1.318	0.11	0.280	0.369
	GSM850	GPRS 3 Tx slots	Right Side	5	Hotspot On	251	848.8	28.30	29.50	1.318	0.17	0.115	0.152
	GSM850	GPRS 3 Tx slots	Bottom Side	5	Hotspot On	251	848.8	28.30	29.50	1.318	0.01	0.276	0.364
	GSM1900	GPRS 4 Tx slots	Front	5	Hotspot On	810	1909.8	18.93	19.00	1.016	0.01	0.355	0.361
	GSM1900	GPRS 4 Tx slots	Back	5	Hotspot On	810	1909.8	18.93	19.00	1.016	0.01	0.396	0.402
	GSM1900	GPRS 4 Tx slots	Left Side	5	Hotspot On	810	1909.8	18.93	19.00	1.016	0.02	0.016	0.016
	GSM1900	GPRS 4 Tx slots	Right Side	5	Hotspot On	810	1909.8	18.93	19.00	1.016	0.02	0.017	0.017
	GSM1900	GPRS 4 Tx slots	Bottom Side	5	Hotspot On	810	1909.8	18.93	19.00	1.016	0.03	0.675	0.686
	GSM1900	GPRS 4 Tx slots	Bottom Side	5	Hotspot On	512	1850.2	18.65	19.00	1.084	0.01	0.628	0.681
18	GSM1900	GPRS 4 Tx slots	Bottom Side	5	Hotspot On	661	1880	18.65	19.00	1.084	0.07	0.655	<b>0.710</b>

**<WCDMA SAR>**

Plot No.	Band	Mode	Test Position	Gap (mm)	Power Mode	Ch.	Freq. (MHz)	Average Power (dBm)	Tune-Up Limit (dBm)	Tune-up Scaling Factor	Power Drift (dB)	Measured 1g SAR (W/kg)	Reported 1g SAR (W/kg)
	WCDMA Band V	RMC 12.2Kbps	Front	5	Hotspot On	4182	836.4	20.76	21.80	1.271	0.11	0.620	0.788
	WCDMA Band V	RMC 12.2Kbps	Back	5	Hotspot On	4182	836.4	20.76	21.80	1.271	-0.1	0.786	0.999
	WCDMA Band V	RMC 12.2Kbps	Back	5	Hotspot On	4132	826.4	20.69	21.80	1.291	0.04	0.809	1.045
19	WCDMA Band V	RMC 12.2Kbps	Back	5	Hotspot On	4233	846.6	20.74	21.80	1.276	0.03	0.923	<b>1.178</b>
	WCDMA Band V	RMC 12.2Kbps	Left Side	5	Hotspot On	4182	836.4	20.76	21.80	1.271	0.18	0.289	0.367
	WCDMA Band V	RMC 12.2Kbps	Right Side	5	Hotspot On	4182	836.4	20.76	21.80	1.271	0.15	0.135	0.172
	WCDMA Band V	RMC 12.2Kbps	Bottom Side	5	Hotspot On	4182	836.4	20.76	21.80	1.271	0.15	0.317	0.403
	WCDMA Band II	RMC 12.2Kbps	Front	5	Hotspot On	9538	1907.6	12.68	13.80	1.294	0.03	0.397	0.514
	WCDMA Band II	RMC 12.2Kbps	Back	5	Hotspot On	9538	1907.6	12.68	13.80	1.294	0.04	0.477	0.617
	WCDMA Band II	RMC 12.2Kbps	Left Side	5	Hotspot On	9538	1907.6	12.68	13.80	1.294	-0.06	0.017	0.022
	WCDMA Band II	RMC 12.2Kbps	Right Side	5	Hotspot On	9538	1907.6	12.68	13.80	1.294	0.09	0.022	0.028
20	WCDMA Band II	RMC 12.2Kbps	Bottom Side	5	Hotspot On	9538	1907.6	12.68	13.80	1.294	0.04	0.681	<b>0.881</b>
	WCDMA Band II	RMC 12.2Kbps	Bottom Side	5	Hotspot On	9262	1852.4	12.40	13.80	1.380	0.01	0.629	0.868
	WCDMA Band II	RMC 12.2Kbps	Bottom Side	5	Hotspot On	9400	1880	12.39	13.80	1.384	0.07	0.612	0.847



<CDMA2000 SAR>

Plot No.	Band	Mode	Test Position	Gap (mm)	Power Mode	Ch.	Freq. (MHz)	Average Power (dBm)	Tune-Up Limit (dBm)	Tune-up Scaling Factor	Power Drift (dB)	Measured 1g SAR (W/kg)	Reported 1g SAR (W/kg)
	CDMA2000 BC0	RTAP 153.6Kbps	Front	5	Hotspot On	777	848.31	19.89	21.00	1.291	0.05	0.437	0.564
21	CDMA2000 BC0	RTAP 153.6Kbps	Back	5	Hotspot On	777	848.31	19.89	21.00	1.291	0.1	0.595	0.768
	CDMA2000 BC0	RTAP 153.6Kbps	Left Side	5	Hotspot On	777	848.31	19.89	21.00	1.291	0.02	0.243	0.314
	CDMA2000 BC0	RTAP 153.6Kbps	Right Side	5	Hotspot On	777	848.31	19.89	21.00	1.291	0.06	0.122	0.158
	CDMA2000 BC0	RTAP 153.6Kbps	Bottom Side	5	Hotspot On	777	848.31	19.89	21.00	1.291	0.01	0.236	0.305
	CDMA2000 BC1	RTAP 153.6Kbps	Front	5	Hotspot On	1175	1908.75	12.88	14.00	1.294	0.08	0.358	0.463
	CDMA2000 BC1	RTAP 153.6Kbps	Back	5	Hotspot On	1175	1908.75	12.88	14.00	1.294	0.09	0.454	0.588
	CDMA2000 BC1	RTAP 153.6Kbps	Left Side	5	Hotspot On	1175	1908.75	12.88	14.00	1.294	0.15	0.013	0.017
	CDMA2000 BC1	RTAP 153.6Kbps	Right Side	5	Hotspot On	1175	1908.75	12.88	14.00	1.294	0.04	0.063	0.082
	CDMA2000 BC1	RTAP 153.6Kbps	Bottom Side	5	Hotspot On	1175	1908.75	12.88	14.00	1.294	0.01	0.665	0.861
22	CDMA2000 BC1	RTAP 153.6Kbps	Bottom Side	5	Hotspot On	25	1851.25	12.66	14.00	1.361	0.07	0.682	0.929
	CDMA2000 BC1	RTAP 153.6Kbps	Bottom Side	5	Hotspot On	600	1880	12.75	14.00	1.334	0.04	0.669	0.892



<LTE SAR>

Table with 17 columns: Plot No., Band, BW (MHz), Modulation, RB Size, RB Offset, Test Position, Gap (mm), Power Mode, Ch., Freq. (MHz), Average Power (dBm), Tune-Up Limit (dBm), Tune-up Scaling Factor, Power Drift (dB), Measured 1g SAR (W/kg), Reported 1g SAR (W/kg). Rows include test results for LTE Bands 13, 5, 66, and 23, 24, 25.



Plot No.	Band	BW (MHz)	Modulation	RB Size	RB Offset	Test Position	Gap (mm)	Power Mode	Ch.	Freq. (MHz)	Average Power (dBm)	Tune-Up Limit (dBm)	Tune-up Scaling Factor	Power Drift (dB)	Measured 1g SAR (W/kg)	Reported 1g SAR (W/kg)
	LTE Band 2	20M	QPSK	1	0	Front	5	Hotspot On	19100	1900	13.08	14.00	1.236	0.05	0.427	0.528
	LTE Band 2	20M	QPSK	50	0	Front	5	Hotspot On	19100	1900	13.17	14.00	1.211	0.02	0.417	0.505
	LTE Band 2	20M	QPSK	1	0	Back	5	Hotspot On	19100	1900	13.08	14.00	1.236	0.03	0.525	0.649
	LTE Band 2	20M	QPSK	50	0	Back	5	Hotspot On	19100	1900	13.17	14.00	1.211	0.05	0.513	0.621
	LTE Band 2	20M	QPSK	1	0	Left Side	5	Hotspot On	19100	1900	13.08	14.00	1.236	0.08	0.017	0.021
	LTE Band 2	20M	QPSK	50	0	Left Side	5	Hotspot On	19100	1900	13.17	14.00	1.211	0.01	0.017	0.021
	LTE Band 2	20M	QPSK	1	0	Right Side	5	Hotspot On	19100	1900	13.08	14.00	1.236	0.05	0.052	0.064
	LTE Band 2	20M	QPSK	50	0	Right Side	5	Hotspot On	19100	1900	13.17	14.00	1.211	0.02	0.050	0.061
	LTE Band 2	20M	QPSK	1	0	Bottom Side	5	Hotspot On	19100	1900	13.08	14.00	1.236	0.05	0.688	0.850
26	LTE Band 2	20M	QPSK	1	0	Bottom Side	5	Hotspot On	18700	1860	12.82	14.00	1.312	0.01	0.667	0.875
	LTE Band 2	20M	QPSK	1	0	Bottom Side	5	Hotspot On	18900	1880	13.00	14.00	1.259	0.03	0.667	0.840
	LTE Band 2	20M	QPSK	50	0	Bottom Side	5	Hotspot On	19100	1900	13.17	14.00	1.211	0.06	0.684	0.828
	LTE Band 2	20M	QPSK	50	0	Bottom Side	5	Hotspot On	18700	1860	12.62	14.00	1.374	0.04	0.625	0.859
	LTE Band 2	20M	QPSK	50	0	Bottom Side	5	Hotspot On	18900	1880	12.83	14.00	1.309	0.08	0.644	0.843
	LTE Band 2	20M	QPSK	100	0	Bottom Side	5	Hotspot On	19100	1900	13.12	14.00	1.225	0.01	0.665	0.814
	LTE Band 7	20M	QPSK	1	0	Front	5	Hotspot On	20850	2510	15.27	16.20	1.239	0.12	0.312	0.387
	LTE Band 7	20M	QPSK	50	0	Front	5	Hotspot On	20850	2510	15.25	16.20	1.245	-0.05	0.310	0.386
	LTE Band 7	20M	QPSK	1	0	Back	5	Hotspot On	20850	2510	15.27	16.20	1.239	0.07	0.520	0.644
27	LTE Band 7	20M	QPSK	50	0	Back	5	Hotspot On	20850	2510	15.25	16.20	1.245	0.11	0.521	0.648
	LTE Band 7	20M	QPSK	1	0	Right Side	5	Hotspot On	20850	2510	15.27	16.20	1.239	0.09	0.371	0.460
	LTE Band 7	20M	QPSK	50	0	Right Side	5	Hotspot On	20850	2510	15.25	16.20	1.245	0.07	0.377	0.469
	LTE Band 7	20M	QPSK	1	0	Bottom Side	5	Hotspot On	20850	2510	15.27	16.20	1.239	0.12	0.132	0.164
	LTE Band 7	20M	QPSK	50	0	Bottom Side	5	Hotspot On	20850	2510	15.25	16.20	1.245	0.05	0.133	0.166



<WLAN 2.4GHz SAR>

Plot No.	Band	Mode	Test Position	Gap (mm)	Ch.	Freq. (MHz)	Average Power (dBm)	Tune-Up Limit (dBm)	Tune-up Scaling Factor	Duty Cycle %	Duty Cycle Scaling Factor	Power Drift (dB)	Max Area Scan SAR	Measured 1g SAR (W/kg)	Reported 1g SAR (W/kg)
	WLAN2.4GHz	802.11b 1Mbps	Front	5	11	2462	16.79	17.00	1.050	100	1.000	0.02	0.423	0.269	0.282
28	WLAN2.4GHz	802.11b 1Mbps	Back	5	11	2462	16.79	17.00	1.050	100	1.000	0.07	0.674	0.350	0.367
	WLAN2.4GHz	802.11b 1Mbps	Left Side	5	11	2462	16.79	17.00	1.050	100	1.000		0.582		
	WLAN2.4GHz	802.11b 1Mbps	Top Side	5	11	2462	16.79	17.00	1.050	100	1.000		0.137		

<WLAN 5GHz SAR>

Plot No.	Band	Mode	Test Position	Gap (mm)	Ch.	Freq. (MHz)	Average Power (dBm)	Tune-Up Limit (dBm)	Tune-up Scaling Factor	Duty Cycle %	Duty Cycle Scaling Factor	Power Drift (dB)	Max Area Scan SAR	Measured 1g SAR (W/kg)	Reported 1g SAR (W/kg)
	WLAN5.2GHz	802.11a 6Mbps	Front	5	40	5200	17.26	17.50	1.057	98.28	1.018	0.15	1.009	0.477	0.513
	WLAN5.2GHz	802.11a 6Mbps	Back	5	40	5200	17.26	17.50	1.057	98.28	1.018	0.05	1.836	0.758	0.815
29	WLAN5.2GHz	802.11a 6Mbps	Left Side	5	40	5200	17.26	17.50	1.057	98.28	1.018	0.07	1.993	0.848	0.912
	WLAN5.2GHz	802.11a 6Mbps	Top Side	5	40	5200	17.26	17.50	1.057	98.28	1.018		0.378		
	WLAN5.2GHz	802.11a 6Mbps	Back	5	36	5180	17.21	17.50	1.069	98.28	1.018	0.07		0.738	0.803
	WLAN5.2GHz	802.11a 6Mbps	Left Side	5	36	5180	17.21	17.50	1.069	98.28	1.018	0.01		0.765	0.833
	WLAN 5.8GHz	802.11a 6Mbps	Front	5	157	5785	16.89	17.50	1.151	98.28	1.018	0.05	0.963	0.333	0.390
	WLAN 5.8GHz	802.11a 6Mbps	Back	5	157	5785	16.89	17.50	1.151	98.28	1.018	-0.02	1.52	0.631	0.739
30	WLAN 5.8GHz	802.11a 6Mbps	Left Side	5	157	5785	16.89	17.50	1.151	98.28	1.018	0.01	1.911	0.733	0.859
	WLAN 5.8GHz	802.11a 6Mbps	Top Side	5	157	5785	16.89	17.50	1.151	98.28	1.018		0.914		
	WLAN 5.8GHz	802.11a 6Mbps	Left Side	5	149	5745	16.86	17.50	1.159	98.28	1.018	-0.05		0.610	0.720

<Bluetooth SAR>

Plot No.	Band	Mode	Test Position	Gap (mm)	Ch.	Freq. (MHz)	Average Power (dBm)	Tune-Up Limit (dBm)	Tune-up Scaling Factor	Duty Cycle %	Duty Cycle Scaling Factor	Power Drift (dB)	Measured 1g SAR (W/kg)	Reported 1g SAR (W/kg)
	Bluetooth	1Mbps	Front	5	0	2402	16.52	16.60	1.019	77.02	1.082	0.05	0.255	0.281
31	Bluetooth	1Mbps	Back	5	0	2402	16.52	16.60	1.019	77.02	1.082	0.06	0.286	0.315
	Bluetooth	1Mbps	Left Side	5	0	2402	16.52	16.60	1.019	77.02	1.082	0.09	0.207	0.228
	Bluetooth	1Mbps	Top Side	5	0	2402	16.52	16.60	1.019	77.02	1.082	0.16	0.080	0.088





**15.3 Body Worn Accessory SAR**

**<GSM SAR>**

Plot No.	Band	Mode	Test Position	Gap (mm)	Power Mode	Ch.	Freq. (MHz)	Average Power (dBm)	Tune-Up Limit (dBm)	Tune-up Scaling Factor	Power Drift (dB)	Measured 1g SAR (W/kg)	Reported 1g SAR (W/kg)
	GSM850	GPRS 3 Tx slots	Front	5	P-Sensor On	251	848.8	28.30	29.50	1.318	0.14	0.504	0.664
32	GSM850	GPRS 3 Tx slots	Back	5	P-Sensor On	251	848.8	28.30	29.50	1.318	0.19	0.695	<b>0.916</b>
	GSM850	GPRS 3 Tx slots	Back	5	P-Sensor On	128	824.2	27.95	29.50	1.429	0.03	0.631	0.902
	GSM850	GPRS 3 Tx slots	Back	5	P-Sensor On	189	836.4	28.23	29.50	1.340	0.08	0.625	0.837
	GSM1900	GPRS 4 Tx slots	Front	5	P-Sensor On	810	1909.8	18.93	19.00	1.016	0.01	0.355	0.361
33	GSM1900	GPRS 4 Tx slots	Back	5	P-Sensor On	810	1909.8	18.93	19.00	1.016	0.01	0.396	<b>0.402</b>
	GSM1900	GSM 1 Tx slot	Back	5	P-Sensor On	810	1909.8	22.79	23.00	1.050	0.02	0.348	0.365

**<WCDMA SAR>**

Plot No.	Band	Mode	Test Position	Gap (mm)	Power Mode	Ch.	Freq. (MHz)	Average Power (dBm)	Tune-Up Limit (dBm)	Tune-up Scaling Factor	Power Drift (dB)	Measured 1g SAR (W/kg)	Reported 1g SAR (W/kg)
	WCDMA Band V	RMC 12.2Kbps	Front	5	P-Sensor On	4182	836.4	20.76	21.80	1.271	0.11	0.620	0.788
	WCDMA Band V	RMC 12.2Kbps	Back	5	P-Sensor On	4182	836.4	20.76	21.80	1.271	-0.1	0.786	0.999
	WCDMA Band V	RMC 12.2Kbps	Back	5	P-Sensor On	4132	826.4	20.69	21.80	1.291	0.04	0.809	1.045
34	WCDMA Band V	RMC 12.2Kbps	Back	5	P-Sensor On	4233	846.6	20.74	21.80	1.276	0.03	0.923	<b>1.178</b>
	WCDMA Band II	RMC 12.2Kbps	Front	5	P-Sensor On	9538	1907.6	15.38	16.50	1.294	-0.01	0.737	0.954
	WCDMA Band II	RMC 12.2Kbps	Front	5	P-Sensor On	9400	1880	15.33	16.50	1.309	0.05	0.745	0.975
	WCDMA Band II	RMC 12.2Kbps	Front	5	P-Sensor On	9262	1852.4	15.30	16.50	1.318	0.05	0.809	1.066
	WCDMA Band II	RMC 12.2Kbps	Back	5	P-Sensor On	9538	1907.6	15.38	16.50	1.294	-0.1	0.862	1.116
	WCDMA Band II	RMC 12.2Kbps	Back	5	P-Sensor On	9400	1880	15.33	16.50	1.309	0.18	0.826	1.081
35	WCDMA Band II	RMC 12.2Kbps	Back	5	P-Sensor On	9262	1852.4	15.30	16.50	1.318	0.08	0.860	<b>1.134</b>

**<CDMA2000 SAR>**

Plot No.	Band	Mode	Test Position	Gap (mm)	Power Mode	Ch.	Freq. (MHz)	Average Power (dBm)	Tune-Up Limit (dBm)	Tune-up Scaling Factor	Power Drift (dB)	Measured 1g SAR (W/kg)	Reported 1g SAR (W/kg)
	CDMA2000 BC0	RC3 SO32(F+SCH)	Front	5	P-Sensor On	777	848.31	19.92	21.00	1.282	0.02	0.538	0.690
36	CDMA2000 BC0	RC3 SO32(F+SCH)	Back	5	P-Sensor On	777	848.31	19.92	21.00	1.282	0.15	0.648	<b>0.831</b>
	CDMA2000 BC0	RC3 SO32(F+SCH)	Back	5	P-Sensor On	1013	824.7	19.60	21.00	1.380	0.12	0.595	0.821
	CDMA2000 BC0	RC3 SO32(F+SCH)	Back	5	P-Sensor On	384	836.52	19.75	21.00	1.334	0.02	0.607	0.809
	CDMA2000 BC1	RC3 SO32(F+SCH)	Front	5	P-Sensor On	1175	1908.75	15.50	16.50	1.259	0.04	0.690	0.869
	CDMA2000 BC1	RC3 SO32(F+SCH)	Front	5	P-Sensor On	25	1851.25	15.33	16.50	1.309	0.01	0.795	1.041
	CDMA2000 BC1	RC3 SO32(F+SCH)	Front	5	P-Sensor On	600	1880	15.28	16.50	1.324	0.09	0.706	0.935
	CDMA2000 BC1	RC3 SO32(F+SCH)	Back	5	P-Sensor On	1175	1908.75	15.50	16.50	1.259	0.01	0.831	1.046
37	CDMA2000 BC1	RC3 SO32(F+SCH)	Back	5	P-Sensor On	25	1851.25	15.33	16.50	1.309	-0.03	0.886	<b>1.160</b>
	CDMA2000 BC1	RC3 SO32(F+SCH)	Back	5	P-Sensor On	600	1880	15.28	16.50	1.324	0.08	0.851	1.127



<LTE SAR>

Plot No.	Band	BW (MHz)	Modulation	RB Size	RB Offset	Test Position	Gap (mm)	Power Mode	Ch.	Freq. (MHz)	Average Power (dBm)	Tune-Up Limit (dBm)	Tune-up Scaling Factor	Power Drift (dB)	Measured 1g SAR (W/kg)	Reported 1g SAR (W/kg)
	LTE Band 13	10M	QPSK	1	0	Front	5	P-Sensor On	23230	782	21.14	22.00	1.219	0.18	0.550	0.670
	LTE Band 13	10M	QPSK	25	0	Front	5	P-Sensor On	23230	782	21.12	22.00	1.225	0.18	0.493	0.604
38	LTE Band 13	10M	QPSK	1	0	Back	5	P-Sensor On	23230	782	21.14	22.00	1.219	0.03	0.722	<b>0.880</b>
	LTE Band 13	10M	QPSK	25	0	Back	5	P-Sensor On	23230	782	21.12	22.00	1.225	0.05	0.652	0.798
	LTE Band 13	10M	QPSK	50	0	Back	5	P-Sensor On	23230	782	21.14	22.00	1.219	0.03	0.671	0.818
	LTE Band 5	10M	QPSK	1	25	Front	5	P-Sensor On	20525	836.5	20.76	21.80	1.271	0.06	0.712	0.905
	LTE Band 5	10M	QPSK	25	25	Front	5	P-Sensor On	20525	836.5	20.86	21.80	1.242	0.08	0.634	0.787
	LTE Band 5	10M	QPSK	50	0	Front	5	P-Sensor On	20525	836.5	20.90	21.80	1.230	0.14	0.638	0.785
39	LTE Band 5	10M	QPSK	1	25	Back	5	P-Sensor On	20525	836.5	20.76	21.80	1.271	0.18	0.926	<b>1.177</b>
	LTE Band 5	10M	QPSK	25	25	Back	5	P-Sensor On	20525	836.5	20.86	21.80	1.242	0.19	0.822	1.021
	LTE Band 5	10M	QPSK	50	0	Back	5	P-Sensor On	20525	836.5	20.90	21.80	1.230	0.18	0.828	1.019
	LTE Band 66	20M	QPSK	1	0	Front	5	P-Sensor On	132072	1720	15.79	16.00	1.050	-0.08	1.060	1.113
	LTE Band 66	20M	QPSK	1	0	Front	5	P-Sensor On	132322	1745	15.74	16.00	1.062	-0.07	0.981	1.042
	LTE Band 66	20M	QPSK	1	0	Front	5	P-Sensor On	132572	1770	15.71	16.00	1.069	-0.04	0.999	1.068
40	LTE Band 66	20M	QPSK	50	0	Front	5	P-Sensor On	132072	1720	15.78	16.00	1.052	-0.07	1.110	<b>1.168</b>
	LTE Band 66	20M	QPSK	50	0	Front	5	P-Sensor On	132322	1745	15.70	16.00	1.072	-0.04	1.080	1.157
	LTE Band 66	20M	QPSK	50	0	Front	5	P-Sensor On	132572	1770	15.65	16.00	1.084	-0.06	0.973	1.055
	LTE Band 66	20M	QPSK	100	0	Front	5	P-Sensor On	132072	1720	15.63	16.00	1.089	-0.03	1.030	1.122
	LTE Band 66	20M	QPSK	1	0	Back	5	P-Sensor On	132072	1720	15.79	16.00	1.050	-0.01	1.050	1.102
	LTE Band 66	20M	QPSK	1	0	Back	5	P-Sensor On	132322	1745	15.74	16.00	1.062	-0.05	1.060	1.125
	LTE Band 66	20M	QPSK	1	0	Back	5	P-Sensor On	132572	1770	15.71	16.00	1.069	-0.05	1.040	1.112
	LTE Band 66	20M	QPSK	50	0	Back	5	P-Sensor On	132072	1720	15.78	16.00	1.052	-0.02	1.030	1.084
	LTE Band 66	20M	QPSK	50	0	Back	5	P-Sensor On	132322	1745	15.70	16.00	1.072	-0.03	1.090	1.168
	LTE Band 66	20M	QPSK	50	0	Back	5	P-Sensor On	132572	1770	15.65	16.00	1.084	-0.06	0.989	1.072
	LTE Band 66	20M	QPSK	100	0	Back	5	P-Sensor On	132072	1720	15.63	16.00	1.089	-0.06	0.999	1.088
	LTE Band 2	20M	QPSK	1	0	Front	5	P-Sensor On	19100	1900	15.78	16.50	1.180	-0.06	0.698	0.824
	LTE Band 2	20M	QPSK	1	0	Front	5	P-Sensor On	18700	1860	15.55	16.50	1.245	0.06	0.731	0.910
	LTE Band 2	20M	QPSK	1	0	Front	5	P-Sensor On	18900	1880	15.62	16.50	1.225	-0.03	0.711	0.871
	LTE Band 2	20M	QPSK	50	0	Front	5	P-Sensor On	19100	1900	15.86	16.50	1.159	-0.07	0.681	0.789
	LTE Band 2	20M	QPSK	100	0	Front	5	P-Sensor On	19100	1900	15.81	16.50	1.172	-0.03	0.680	0.797
	LTE Band 2	20M	QPSK	1	0	Back	5	P-Sensor On	19100	1900	15.78	16.50	1.180	-0.16	0.931	1.099
41	LTE Band 2	20M	QPSK	1	0	Back	5	P-Sensor On	18700	1860	15.55	16.50	1.245	0.06	0.904	<b>1.125</b>
	LTE Band 2	20M	QPSK	1	0	Back	5	P-Sensor On	18900	1880	15.62	16.50	1.225	0.04	0.904	1.107
	LTE Band 2	20M	QPSK	50	0	Back	5	P-Sensor On	19100	1900	15.86	16.50	1.159	-0.07	0.901	1.044
	LTE Band 2	20M	QPSK	50	0	Back	5	P-Sensor On	18700	1860	15.47	16.50	1.268	-0.05	0.712	0.903
	LTE Band 2	20M	QPSK	50	0	Back	5	P-Sensor On	18900	1880	15.66	16.50	1.213	-0.04	0.725	0.880
	LTE Band 2	20M	QPSK	100	0	Back	5	P-Sensor On	19100	1900	15.81	16.50	1.172	-0.02	0.761	0.892
	LTE Band 7	20M	QPSK	1	0	Front	5	P-Sensor On	20850	2510	15.27	16.20	1.239	0.12	0.312	0.387
	LTE Band 7	20M	QPSK	50	0	Front	5	P-Sensor On	20850	2510	15.25	16.20	1.245	-0.05	0.310	0.386
	LTE Band 7	20M	QPSK	1	0	Back	5	P-Sensor On	20850	2510	15.27	16.20	1.239	0.07	0.520	0.644
42	LTE Band 7	20M	QPSK	50	0	Back	5	P-Sensor On	20850	2510	15.25	16.20	1.245	0.11	0.521	<b>0.648</b>



<WLAN 2.4GHz SAR>

Plot No.	Band	Mode	Test Position	Gap (mm)	Ch.	Freq. (MHz)	Average Power (dBm)	Tune-Up Limit (dBm)	Tune-up Scaling Factor	Duty Cycle %	Duty Cycle Scaling Factor	Power Drift (dB)	Max Area Scan SAR	Measured 1g SAR (W/kg)	Reported 1g SAR (W/kg)
	WLAN2.4GHz	802.11b 1Mbps	Front	5	11	2462	16.79	17.00	1.050	100	1.000	0.02	0.423	0.269	0.282
43	WLAN2.4GHz	802.11b 1Mbps	Back	5	11	2462	16.79	17.00	1.050	100	1.000	0.07	0.674	0.350	<b>0.367</b>

<WLAN 5GHz SAR>

Plot No.	Band	Mode	Test Position	Gap (mm)	Ch.	Freq. (MHz)	Average Power (dBm)	Tune-Up Limit (dBm)	Tune-up Scaling Factor	Duty Cycle %	Duty Cycle Scaling Factor	Power Drift (dB)	Max Area Scan SAR	Measured 1g SAR (W/kg)	Reported 1g SAR (W/kg)
	WLAN5.3GHz	802.11a 6Mbps	Front	5	60	5300	17.27	17.50	1.054	98.28	1.018	0.03	1.108	0.504	0.541
	WLAN5.3GHz	802.11a 6Mbps	Back	5	60	5300	17.27	17.50	1.054	98.28	1.018	0.01	1.980	0.852	0.915
44	WLAN5.3GHz	802.11a 6Mbps	Back	5	64	5320	17.23	17.50	1.064	98.28	1.018	0.02		0.898	<b>0.973</b>
	WLAN5.5GHz	802.11a 6Mbps	Front	5	116	5580	17.18	17.50	1.076	98.28	1.018	0.06	1.227	0.541	0.593
	WLAN5.5GHz	802.11a 6Mbps	Back	5	116	5580	17.18	17.50	1.076	98.28	1.018	0.09	2.359	0.937	1.027
45	WLAN5.5GHz	802.11a 6Mbps	Back	5	100	5500	17.07	17.50	1.104	98.28	1.018	0.07		1.030	<b>1.158</b>
	WLAN 5.8GHz	802.11a 6Mbps	Front	5	157	5785	16.89	17.50	1.151	98.28	1.018	0.05	0.963	0.333	0.390
46	WLAN 5.8GHz	802.11a 6Mbps	Back	5	157	5785	16.89	17.50	1.151	98.28	1.018	-0.02	1.52	0.631	<b>0.739</b>

<Bluetooth SAR>

Plot No.	Band	Mode	Test Position	Gap (mm)	Ch.	Freq. (MHz)	Average Power (dBm)	Tune-Up Limit (dBm)	Tune-up Scaling Factor	Duty Cycle %	Duty Cycle Scaling Factor	Power Drift (dB)	Measured 1g SAR (W/kg)	Reported 1g SAR (W/kg)
	Bluetooth	1Mbps	Front	5	0	2402	16.52	16.60	1.019	77.02	1.082	0.05	0.255	0.281
47	Bluetooth	1Mbps	Back	5	0	2402	16.52	16.60	1.019	77.02	1.082	0.06	0.286	<b>0.315</b>



**15.4 Product specific 10g SAR**

**<GSM SAR>**

Plot No.	Band	Mode	Test Position	Gap (mm)	Power Mode	Ch.	Freq. (MHz)	Average Power (dBm)	Tune-Up Limit (dBm)	Tune-up Scaling Factor	Power Drift (dB)	Measured 10g SAR (W/kg)	Reported 10g SAR (W/kg)
48	GSM850	GPRS 3 Tx slots	Back	0	Full	251	848.8	30.31	31.00	1.172	0.09	0.711	<b>0.833</b>
	GSM1900	GPRS 3 Tx slots	Front	0	Handheld On	810	1909.8	24.79	26.50	1.483	0.07	1.250	1.853
	GSM1900	GPRS 3 Tx slots	Back	0	Handheld On	810	1909.8	24.79	26.50	1.483	0.03	2.020	2.995
49	GSM1900	GPRS 3 Tx slots	Back	0	Handheld On	512	1850.2	24.62	26.50	1.542	0.05	2.200	<b>3.392</b>
	GSM1900	GPRS 3 Tx slots	Back	0	Handheld On	661	1880	24.71	26.50	1.510	0.05	2.160	3.262
	GSM1900	GPRS 3 Tx slots	Bottom Side	0	Handheld On	810	1909.8	24.79	26.50	1.483	0.08	0.938	1.391

**<WCDMA SAR>**

Plot No.	Band	Mode	Test Position	Gap (mm)	Power Mode	Ch.	Freq. (MHz)	Average Power (dBm)	Tune-Up Limit (dBm)	Tune-up Scaling Factor	Power Drift (dB)	Measured 10g SAR (W/kg)	Reported 10g SAR (W/kg)
	WCDMA Band V	RMC 12.2Kbps	Front	0	Full	4182	836.4	23.30	24.00	1.175	0.01	0.465	0.546
50	WCDMA Band V	RMC 12.2Kbps	Back	0	Full	4182	836.4	23.30	24.00	1.175	0.05	0.566	<b>0.665</b>
	WCDMA Band II	RMC 12.2Kbps	Front	0	Handheld On	9538	1907.6	19.31	20.30	1.256	0.07	1.930	2.424
	WCDMA Band II	RMC 12.2Kbps	Front	0	Handheld On	9262	1852.4	18.96	20.30	1.361	0.02	2.030	2.764
	WCDMA Band II	RMC 12.2Kbps	Front	0	Handheld On	9400	1880	19.02	20.30	1.343	0.07	1.870	2.511
	WCDMA Band II	RMC 12.2Kbps	Back	0	Handheld On	9538	1907.6	19.31	20.30	1.256	0.06	2.590	3.253
51	WCDMA Band II	RMC 12.2Kbps	Back	0	Handheld On	9262	1852.4	18.96	20.30	1.361	0.08	2.470	<b>3.363</b>
	WCDMA Band II	RMC 12.2Kbps	Back	0	Handheld On	9400	1880	19.02	20.30	1.343	0.06	2.500	3.357
	WCDMA Band II	RMC 12.2Kbps	Bottom Side	0	Handheld On	9538	1907.6	19.31	20.30	1.256	0.04	1.300	1.633

**<CDMA2000 SAR>**

Plot No.	Band	Mode	Test Position	Gap (mm)	Power Mode	Ch.	Freq. (MHz)	Average Power (dBm)	Tune-Up Limit (dBm)	Tune-up Scaling Factor	Power Drift (dB)	Measured 10g SAR (W/kg)	Reported 10g SAR (W/kg)
	CDMA2000 BC0	RTAP 153.6Kbps	Front	0	Full	777	848.31	24.11	25.00	1.227	0.04	2.280	2.799
	CDMA2000 BC0	RTAP 153.6Kbps	Front	0	Full	1013	824.7	23.95	25.00	1.274	0.04	1.970	2.509
	CDMA2000 BC0	RTAP 153.6Kbps	Front	0	Full	384	836.52	24.04	25.00	1.247	0.07	2.260	2.819
52	CDMA2000 BC0	RTAP 153.6Kbps	Back	0	Full	777	848.31	24.11	25.00	1.227	0.05	2.650	<b>3.253</b>
	CDMA2000 BC0	RTAP 153.6Kbps	Back	0	Full	1013	824.7	23.95	25.00	1.274	0.09	2.340	2.980
	CDMA2000 BC0	RTAP 153.6Kbps	Back	0	Full	384	836.52	24.04	25.00	1.247	0.08	2.510	3.131
	CDMA2000 BC1	RTAP 153.6Kbps	Front	0	Handheld On	1175	1908.75	18.36	19.50	1.300	0.09	1.540	2.002
	CDMA2000 BC1	RTAP 153.6Kbps	Front	0	Handheld On	25	1851.25	18.07	19.50	1.390	0.04	1.590	2.210
	CDMA2000 BC1	RTAP 153.6Kbps	Front	0	Handheld On	600	1880	18.16	19.50	1.361	0.04	1.480	2.015
53	CDMA2000 BC1	RTAP 153.6Kbps	Back	0	Handheld On	1175	1908.75	18.36	19.50	1.300	0.02	2.120	<b>2.756</b>
	CDMA2000 BC1	RTAP 153.6Kbps	Back	0	Handheld On	25	1851.25	18.07	19.50	1.390	0.08	1.980	2.752
	CDMA2000 BC1	RTAP 153.6Kbps	Back	0	Handheld On	600	1880	18.16	19.50	1.361	0.03	1.910	2.600
	CDMA2000 BC1	RTAP 153.6Kbps	Bottom Side	0	Handheld On	1175	1908.75	18.36	19.50	1.300	0.07	1.100	1.430



<LTE SAR>

Plot No.	Band	BW (MHz)	Modulation	RB Size	RB Offset	Test Position	Gap (mm)	Power Mode	Ch.	Freq. (MHz)	Average Power (dBm)	Tune-Up Limit (dBm)	Tune-up Scaling Factor	Power Drift (dB)	Measured 10g SAR (W/kg)	Reported 10g SAR (W/kg)
54	LTE Band 13	10M	QPSK	1	0	Back	0	Full	23230	782	23.00	24.00	1.259	0.01	1.910	<b>2.405</b>
	LTE Band 13	10M	QPSK	25	0	Back	0	Full	23230	782	21.92	23.00	1.282	0.09	1.060	1.359
	LTE Band 13	10M	QPSK	50	0	Back	0	Full	23230	782	21.89	23.00	1.291	0.09	1.050	1.356
	LTE Band 5	10M	QPSK	1	25	Front	0	Full	20525	836.5	23.00	24.00	1.259	0.04	1.710	2.153
	LTE Band 5	10M	QPSK	25	25	Front	0	Full	20525	836.5	21.92	23.00	1.282	0.03	0.925	1.186
	LTE Band 5	10M	QPSK	50	0	Front	0	Full	20525	836.5	21.94	23.00	1.276	0.05	1.100	1.404
55	LTE Band 5	10M	QPSK	1	25	Back	0	Full	20525	836.5	23.00	24.00	1.259	0.03	2.320	<b>2.921</b>
	LTE Band 5	10M	QPSK	25	25	Back	0	Full	20525	836.5	21.92	23.00	1.282	0.09	1.330	1.705
	LTE Band 5	10M	QPSK	50	0	Back	0	Full	20525	836.5	21.94	23.00	1.276	0.07	1.290	1.647
	LTE Band 66	20M	QPSK	1	0	Front	0	Handheld On	132572	1770	18.33	19.30	1.250	0.06	2.030	2.538
	LTE Band 66	20M	QPSK	1	0	Front	0	Handheld On	132072	1720	18.25	19.30	1.274	0.08	2.180	2.776
	LTE Band 66	20M	QPSK	1	0	Front	0	Handheld On	132322	1745	18.29	19.30	1.262	0.05	2.160	2.726
	LTE Band 66	20M	QPSK	50	0	Front	0	Handheld On	132572	1770	18.29	19.30	1.262	0.06	2.030	2.562
	LTE Band 66	20M	QPSK	50	0	Front	0	Handheld On	132072	1720	18.16	19.30	1.300	0.11	2.210	2.873
	LTE Band 66	20M	QPSK	50	0	Front	0	Handheld On	132322	1745	18.27	19.30	1.268	0.09	2.180	2.763
	LTE Band 66	20M	QPSK	100	0	Front	0	Handheld On	132572	1770	18.27	19.30	1.268	0.09	1.990	2.523
	LTE Band 66	20M	QPSK	1	0	Back	0	Handheld On	132572	1770	18.33	19.30	1.250	0.03	2.400	3.001
	LTE Band 66	20M	QPSK	1	0	Back	0	Handheld On	132072	1720	18.25	19.30	1.274	0.01	2.520	3.209
	LTE Band 66	20M	QPSK	1	0	Back	0	Handheld On	132322	1745	18.29	19.30	1.262	0.05	2.520	3.180
	LTE Band 66	20M	QPSK	50	0	Back	0	Handheld On	132572	1770	18.29	19.30	1.262	0.02	2.420	3.054
	56	LTE Band 66	20M	QPSK	50	0	Back	0	Handheld On	132072	1720	18.16	19.30	1.300	0.07	2.550
LTE Band 66		20M	QPSK	50	0	Back	0	Handheld On	132322	1745	18.27	19.30	1.268	0.03	2.570	3.258
LTE Band 66		20M	QPSK	100	0	Back	0	Handheld On	132572	1770	18.27	19.30	1.268	0.06	2.390	3.030
LTE Band 66		20M	QPSK	1	0	Bottom Side	0	Handheld On	132572	1770	18.33	19.30	1.250	0.07	1.700	2.125
LTE Band 66		20M	QPSK	1	0	Bottom Side	0	Handheld On	132072	1720	18.25	19.30	1.274	0.03	1.580	2.012
LTE Band 66		20M	QPSK	1	0	Bottom Side	0	Handheld On	132322	1745	18.29	19.30	1.262	0.08	1.610	2.032
LTE Band 66		20M	QPSK	50	0	Bottom Side	0	Handheld On	132572	1770	18.29	19.30	1.262	0.09	1.700	2.145
LTE Band 66		20M	QPSK	50	0	Bottom Side	0	Handheld On	132072	1720	18.16	19.30	1.300	0.01	1.630	2.119
LTE Band 66		20M	QPSK	50	0	Bottom Side	0	Handheld On	132322	1745	18.27	19.30	1.268	0.08	1.510	1.914
LTE Band 66	20M	QPSK	100	0	Bottom Side	0	Handheld On	132572	1770	18.27	19.30	1.268	0.09	1.580	2.003	



Plot No.	Band	BW (MHz)	Modulation	RB Size	RB Offset	Test Position	Gap (mm)	Power Mode	Ch.	Freq. (MHz)	Average Power (dBm)	Tune-Up Limit (dBm)	Tune-up Scaling Factor	Power Drift (dB)	Measured 10g SAR (W/kg)	Reported 10g SAR (W/kg)
	LTE Band 2	20M	QPSK	1	0	Front	0	Handheld On	19100	1900	19.74	20.60	1.219	0.07	2.110	2.572
	LTE Band 2	20M	QPSK	1	0	Front	0	Handheld On	18700	1860	19.49	20.60	1.291	0.04	2.210	2.854
	LTE Band 2	20M	QPSK	1	0	Front	0	Handheld On	18900	1880	19.62	20.60	1.253	0.08	2.140	2.682
	LTE Band 2	20M	QPSK	50	0	Front	0	Handheld On	19100	1900	19.80	20.60	1.202	0.09	2.160	2.597
	LTE Band 2	20M	QPSK	50	0	Front	0	Handheld On	18700	1860	19.30	20.60	1.349	0.09	2.140	2.887
	LTE Band 2	20M	QPSK	50	0	Front	0	Handheld On	18900	1880	19.48	20.60	1.294	0.06	2.050	2.653
	LTE Band 2	20M	QPSK	100	0	Front	0	Handheld On	19100	1900	19.77	20.60	1.211	0.11	2.120	2.566
	LTE Band 2	20M	QPSK	1	0	Back	0	Handheld On	19100	1900	19.74	20.60	1.219	0.03	2.780	3.389
	LTE Band 2	20M	QPSK	1	0	Back	0	Handheld On	18700	1860	19.49	20.60	1.291	0.01	2.690	3.473
	LTE Band 2	20M	QPSK	1	0	Back	0	Handheld On	18900	1880	19.62	20.60	1.253	0.12	2.670	3.346
	LTE Band 2	20M	QPSK	50	0	Back	0	Handheld On	19100	1900	19.80	20.60	1.202	0.05	2.830	3.402
57	LTE Band 2	20M	QPSK	50	0	Back	0	Handheld On	18700	1860	19.30	20.60	1.349	0.01	2.580	3.480
	LTE Band 2	20M	QPSK	50	0	Back	0	Handheld On	18900	1880	19.48	20.60	1.294	0.11	2.610	3.378
	LTE Band 2	20M	QPSK	100	0	Back	0	Handheld On	19100	1900	19.77	20.60	1.211	0.09	2.800	3.390
	LTE Band 2	20M	QPSK	1	0	Bottom Side	0	Handheld On	19100	1900	19.74	20.60	1.219	0.02	1.760	2.145
	LTE Band 2	20M	QPSK	1	0	Bottom Side	0	Handheld On	18700	1860	19.49	20.60	1.291	0.09	1.960	2.531
	LTE Band 2	20M	QPSK	1	0	Bottom Side	0	Handheld On	18900	1880	19.62	20.60	1.253	0.09	1.830	2.293
	LTE Band 2	20M	QPSK	50	0	Bottom Side	0	Handheld On	19100	1900	19.80	20.60	1.202	0.08	1.800	2.164
	LTE Band 2	20M	QPSK	50	0	Bottom Side	0	Handheld On	18700	1860	19.30	20.60	1.349	0.02	1.890	2.550
	LTE Band 2	20M	QPSK	50	0	Bottom Side	0	Handheld On	18900	1880	19.48	20.60	1.294	0.02	1.750	2.265
	LTE Band 2	20M	QPSK	100	0	Bottom Side	0	Handheld On	19100	1900	19.77	20.60	1.211	0.08	1.710	2.070
	LTE Band 7	20M	QPSK	1	0	Front	0	Handheld On	20850	2510	19.85	20.70	1.216	0.05	1.700	2.068
	LTE Band 7	20M	QPSK	1	0	Front	0	Handheld On	21100	2535	19.75	20.70	1.245	0.01	1.750	2.178
	LTE Band 7	20M	QPSK	1	0	Front	0	Handheld On	21350	2560	19.84	20.70	1.219	0.08	1.800	2.194
	LTE Band 7	20M	QPSK	50	0	Front	0	Handheld On	20850	2510	19.83	20.70	1.222	0.16	1.710	2.089
	LTE Band 7	20M	QPSK	50	0	Front	0	Handheld On	21100	2535	19.72	20.70	1.253	0.05	1.750	2.193
	LTE Band 7	20M	QPSK	50	0	Front	0	Handheld On	21350	2560	19.80	20.70	1.230	0.17	1.790	2.202
	LTE Band 7	20M	QPSK	100	0	Front	0	Handheld On	20850	2510	19.82	20.70	1.225	0.04	1.670	2.045
	LTE Band 7	20M	QPSK	1	0	Back	0	Handheld On	20850	2510	19.85	20.70	1.216	0.09	2.660	3.235
	LTE Band 7	20M	QPSK	1	0	Back	0	Handheld On	21100	2535	19.75	20.70	1.245	-0.11	2.720	3.385
	LTE Band 7	20M	QPSK	1	0	Back	0	Handheld On	21350	2560	19.84	20.70	1.219	0.08	2.750	3.352
	LTE Band 7	20M	QPSK	50	0	Back	0	Handheld On	20850	2510	19.83	20.70	1.222	0.02	2.660	3.250
	LTE Band 7	20M	QPSK	50	0	Back	0	Handheld On	21100	2535	19.72	20.70	1.253	0.09	2.740	3.434
58	LTE Band 7	20M	QPSK	50	0	Back	0	Handheld On	21350	2560	19.80	20.70	1.230	0.04	2.820	3.469
	LTE Band 7	20M	QPSK	100	0	Back	0	Handheld On	20850	2510	19.82	20.70	1.225	0.03	2.640	3.233
	LTE Band 7	20M	QPSK	1	0	Right Side	0	Handheld On	20850	2510	19.85	20.70	1.216	0.06	1.890	2.299
	LTE Band 7	20M	QPSK	1	0	Right Side	0	Handheld On	21100	2535	19.75	20.70	1.245	0.05	1.880	2.340
	LTE Band 7	20M	QPSK	1	0	Right Side	0	Handheld On	21350	2560	19.84	20.70	1.219	0.03	1.980	2.414
	LTE Band 7	20M	QPSK	50	0	Right Side	0	Handheld On	20850	2510	19.83	20.70	1.222	-0.05	1.930	2.358
	LTE Band 7	20M	QPSK	50	0	Right Side	0	Handheld On	21100	2535	19.72	20.70	1.253	0.01	1.920	2.406
	LTE Band 7	20M	QPSK	50	0	Right Side	0	Handheld On	21350	2560	19.80	20.70	1.230	0.08	1.970	2.424
	LTE Band 7	20M	QPSK	100	0	Right Side	0	Handheld On	20850	2510	19.82	20.70	1.225	0.03	1.780	2.180



<WLAN 5GHz SAR>

Plot No.	Band	Mode	Test Position	Gap (mm)	Power Mode	Ch.	Freq. (MHz)	Average Power (dBm)	Tune-Up Limit (dBm)	Tune-up Scaling Factor	Duty Cycle %	Duty Cycle Scaling Factor	Power Drift (dB)	Max Area Scan SAR	Measured 10g SAR (W/kg)	Reported 10g SAR (W/kg)
	WLAN5.3GHz	802.11a 6Mbps	Front	0	Full	60	5300	17.27	17.50	1.054	98.28	1.018	0.02	9.409	0.921	0.989
	WLAN5.3GHz	802.11a 6Mbps	Back	0	Full	60	5300	17.27	17.50	1.054	98.28	1.018	0.01	3.631	0.413	0.443
59	WLAN5.3GHz	802.11a 6Mbps	Left Side	0	Full	60	5300	17.27	17.50	1.054	98.28	1.018	0.04	10.328	1.040	1.116
	WLAN5.3GHz	802.11a 6Mbps	Top Side	0	Full	60	5300	17.27	17.50	1.054	98.28	1.018		1.234		
	WLAN 5.5GHz	802.11a 6Mbps	Front	0	Full	116	5580	17.18	17.50	1.076	98.28	1.018	0.04	12.056	0.995	1.090
	WLAN 5.5GHz	802.11a 6Mbps	Back	0	Full	116	5580	17.18	17.50	1.076	98.28	1.018	0.05	4.134	0.470	0.515
60	WLAN 5.5GHz	802.11a 6Mbps	Left Side	0	Full	116	5580	17.18	17.50	1.076	98.28	1.018	0.02	12.419	1.370	1.501
	WLAN 5.5GHz	802.11a 6Mbps	Top Side	0	Full	116	5580	17.18	17.50	1.076	98.28	1.018		1.448		



**15.5 Repeated SAR Measurement**

**<1g SAR>**

No.	Band	Mode	BW (MHz)	Modulation	RB Size	RB Offset	Test Position	Gap (mm)	Power Mode	Ch.	Freq. (MHz)	Average Power (dBm)	Tune-Up Limit (dBm)	Tune-up Scaling Factor	Duty Cycle %	Duty Cycle Scaling Factor	Power Drift (dB)	Measured 1g SAR (W/kg)	Ratio	Reported 1g SAR (W/kg)
1st	LTE Band 5	-	10M	QPSK	1	25	Back	5	Hotspot On	20525	836.5	20.76	21.80	1.271	-	-	0.18	0.926	1	1.177
2nd	LTE Band 5	-	10M	QPSK	1	25	Back	5	Hotspot On	20525	836.5	20.76	21.80	1.271	-	-	0.05	0.915	1.012	1.163
1st	LTE Band 66	-	20M	QPSK	50	0	Bottom Side	5	Hotspot On	132322	1745	14.46	15.30	1.213	-	-	0.05	0.975	1	1.183
2nd	LTE Band 66	-	20M	QPSK	50	0	Bottom Side	5	Hotspot On	132322	1745	14.46	15.30	1.213	-	-	0.01	0.968	1.007	1.175
1st	LTE Band 2	-	20M	QPSK	1	0	Back	5	P-Sensor On	19100	1900	15.78	16.5	1.180	-	-	-0.16	0.931	1	1.099
2nd	LTE Band 2	-	20M	QPSK	1	0	Back	5	P-Sensor On	19100	1900	15.78	16.5	1.180	-	-	-0.16	0.922	1.010	1.088
1st	LTE Band 66	-	20M	QPSK	50	0	Front	5	P-Sensor On	132072	1720	15.78	16	1.052	-	-	-0.07	1.110	1	1.168
2nd	LTE Band 66	-	20M	QPSK	50	0	Front	5	P-Sensor On	132072	1720	15.78	16	1.052	-	-	-0.07	1.090	1.018	1.147
1st	WLAN5.2GHz	802.11a 6Mbps	-	-	-	-	Left Side	5	Full	40	5200	17.26	17.50	1.057	98.28	1.018	0.07	0.848	1	0.912
2nd	WLAN5.2GHz	802.11a 6Mbps	-	-	-	-	Left Side	5	Full	40	5200	17.26	17.50	1.057	98.28	1.018	0.05	0.836	1.014	0.899
1st	WLAN5.3GHz	802.11a 6Mbps	-	-	-	-	Right Cheek	0	Full	64	5320	17.23	17.50	1.064	98.28	1.018	-0.02	1.020	1	1.105
2nd	WLAN5.3GHz	802.11a 6Mbps	-	-	-	-	Right Cheek	0	Full	64	5320	17.23	17.50	1.064	98.28	1.018	0.03	1.010	1.010	1.094
1st	WLAN5.5GHz	802.11a 6Mbps	-	-	-	-	Back	5	Full	100	5500	17.07	17.50	1.104	98.28	1.018	0.07	1.030	1	1.158
2nd	WLAN5.5GHz	802.11a 6Mbps	-	-	-	-	Back	5	Full	100	5500	17.07	17.50	1.104	98.28	1.018	0.01	1.010	1.020	1.135

**<10g SAR>**

No.	Band	Mode	BW (MHz)	Modulation	RB Size	RB Offset	Test Position	Gap (mm)	Power Mode	Ch.	Freq. (MHz)	Average Power (dBm)	Tune-Up Limit (dBm)	Tune-up Scaling Factor	Power Drift (dB)	Measured 10g SAR (W/kg)	Ratio	Reported 10g SAR (W/kg)
1st	CDMA2000 BC0	RTAP 153.6Kbps	-	-	-	-	Back	0	Full	777	848.31	24.11	25.00	1.227	0.05	2.650	1	3.253
2nd	CDMA2000 BC0	RTAP 153.6Kbps	-	-	-	-	Back	0	Full	777	848.31	24.11	25.00	1.227	0.03	2.610	1.015	3.204
1st	LTE Band 66	-	20M	QPSK	50	0	Front	5	P-Sensor On	132072	1720	15.78	16	1.052	-	-	-0.07	1.110
2nd	LTE Band 66	-	20M	QPSK	50	0	Front	5	P-Sensor On	132072	1720	15.78	16	1.052	-	-	-0.07	1.090
1st	LTE Band 2	-	20M	QPSK	1	0	Back	5	P-Sensor On	19100	1900	15.78	16.5	1.180	-	-	-0.16	0.931
2nd	LTE Band 2	-	20M	QPSK	1	0	Back	5	P-Sensor On	19100	1900	15.78	16.5	1.180	-	-	-0.16	0.922
1st	LTE Band 7	-	20M	QPSK	50	0	Back	0	Handheld On	21350	2560	19.80	20.70	1.230	0.04	2.820	1	3.469
2nd	LTE Band 7	-	20M	QPSK	50	0	Back	0	Handheld On	21350	2560	19.80	20.70	1.230	0.08	2.810	1.004	3.457

**General Note:**

1. Per KDB 865664 D01v01r04, for each frequency band, repeated SAR measurement is required only when the measured SAR is  $\geq 0.8W/kg$ .
2. Per KDB 865664 D01v01r04, if the ratio among the repeated measurement is  $\leq 1.2$  and the measured SAR  $< 1.45W/kg$ , only one repeated measurement is required.
3. Per KDB 865664 D01v01r04, if the extremity repeated SAR is necessary, the same procedures should be adapted for measurements according to extremity and occupational exposure limits by applying a factor of 2.5 for extremity exposure and a factor of 5 for occupational exposure to the corresponding SAR thresholds.
4. The ratio is the difference in percentage between original and repeated *measured SAR*.
5. All measurement SAR result is scaled-up to account for tune-up tolerance and is compliant.



**16. Simultaneous Transmission Analysis**

No.	Simultaneous Transmission Configurations	Portable Handset				Note
		Head	Body-worn	Hotspot	Product specific 10g SAR	
1.	GSM Voice + WLAN2.4GHz	Yes	Yes			
2.	GPRS/EDGE + WLAN2.4GHz	Yes	Yes	Yes	Yes	WLAN Hotspot
3.	WCDMA + WLAN2.4GHz	Yes	Yes	Yes	Yes	WLAN Hotspot
4.	CDMA + WLAN2.4GHz	Yes	Yes	Yes	Yes	WLAN Hotspot
5.	LTE + WLAN2.4GHz	Yes	Yes	Yes	Yes	WLAN Hotspot
6.	GSM Voice + WLAN5.3/5.5GHz	Yes	Yes			
7.	GPRS/EDGE + WLAN5.3/5.5GHz	Yes	Yes		Yes	WLAN Direct (GC only)
8.	WCDMA + WLAN5.3/5.5GHz	Yes	Yes		Yes	WLAN Direct (GC only)
9.	CDMA + WLAN5.3/5.5GHz	Yes	Yes		Yes	WLAN Direct (GC only)
10.	LTE + WLAN5.3/5.5GHz	Yes	Yes		Yes	WLAN Direct (GC only)
11.	GSM Voice + WLAN5.2/5.8GHz	Yes	Yes			
12.	GPRS/EDGE + WLAN5.2/5.8GHz	Yes	Yes	Yes	Yes	WLAN Hotspot/Direct(GC/GO)
13.	WCDMA + WLAN5.2/5.8GHz	Yes	Yes	Yes	Yes	WLAN Hotspot/Direct(GC/GO)
14.	CDMA + WLAN5.2/5.8GHz	Yes	Yes	Yes	Yes	WLAN Hotspot/Direct(GC/GO)
15.	LTE + WLAN5.2/5.8GHz	Yes	Yes	Yes	Yes	WLAN Hotspot/Direct(GC/GO)
16.	GSM Voice + Bluetooth	Yes	Yes			
17.	GPRS/EDGE + Bluetooth	Yes	Yes	Yes	Yes	BT Tethering
18.	WCDMA + Bluetooth	Yes	Yes	Yes	Yes	BT Tethering
19.	CDMA + Bluetooth	Yes	Yes	Yes	Yes	BT Tethering
20.	LTE + Bluetooth	Yes	Yes	Yes	Yes	BT Tethering

**General Note:**

1. This device supports VoIP in GPRS, EGPRS, CDMA, WCDMA and LTE (e.g. for 3rd-party VoIP), LTE supports VoLTE operation.
2. EUT will choose each GSM, WCDMA, CDMA and LTE according to the network signal condition; therefore, they will not operate simultaneously at any moment.
3. All licensed modes share the same antenna part and cannot transmit simultaneously.
4. This device 2.4GHz WLAN support hotspot operation and Bluetooth support tethering applications.
5. This device 2.4GHz WLAN/ 5.2GHz WLAN/5.8GHz WLAN support hotspot operation, and 5.2GHz WLAN/5.8GHz WLAN supports WLAN Direct (GC/GO), and 5.3GHz / 5.5GHz supports WLAN Direct (GC only).
6. EUT will choose either WLAN 2.4GHz or WLAN 5GHz according to the network signal condition; therefore, 2.4GHz WLAN and 5GHz WLAN will not operate simultaneously at any moment though they have independent antenna.
7. WLAN 2.4GHz and Bluetooth share the same antenna so can't transmit simultaneously.
8. According to the EUT character, WLAN 5GHz and Bluetooth can't transmit simultaneously.
9. The worst case 5 GHz WLAN SAR for each configuration was used for SAR summation.
10. Chose the worst zoom scan SAR of WLAN correspondingly for co-located with WWAN analysis.
11. The reported SAR summation is calculated based on the same configuration and test position.
12. Per KDB 447498 D01v06, simultaneous transmission SAR is compliant if,
  - i) 1g Scalar SAR summation < 1.6W/kg and 10g Scalar SAR summation < 4.0W/kg.
  - ii)  $SPLSR = (SAR1 + SAR2)^{1.5} / (\text{min. separation distance, mm})$ , and the peak separation distance is determined from the square root of  $[(x1-x2)^2 + (y1-y2)^2 + (z1-z2)^2]$ , where (x1, y1, z1) and (x2, y2, z2) are the coordinates of the extrapolated peak SAR locations in the zoom scan.
  - iii) If  $SPLSR \leq 0.04$  for 1g SAR,  $SPLSR \leq 0.10$  for 10g SAR simultaneously transmission SAR measurement is not necessary.
  - iv) Simultaneously transmission SAR measurement, and the reported multi-band 1g SAR < 1.6W/kg and 10g SAR < 4.0W/kg.
  - v) The SPLSR calculated results please refer to section 16.5.



16.1 Head Exposure Conditions

WWAN Band	Exposure Position	1	2	3	4	1+2			1+3			1+4			
		WWAN	2.4GHz WLAN	5GHz WLAN	Bluetooth	Summed 1g SAR (W/kg)	SPLSR	Case No	Summed 1g SAR (W/kg)	SPLSR	Case No	Summed 1g SAR (W/kg)	SPLSR	Case No	
		1g SAR (W/kg)	1g SAR (W/kg)	1g SAR (W/kg)	1g SAR (W/kg)										
GSM	GSM850	Right Cheek	0.212	0.469	1.113	0.438	0.68			1.33			0.65		
		Right Tilted	0.149	0.306	0.675	0.370	0.46			0.82			0.52		
		Left Cheek	0.264	0.469	1.113	0.165	0.73			1.38			0.43		
		Left Tilted	0.147	0.469	1.113	0.152	0.62			1.26			0.30		
	GSM1900	Right Cheek	0.156	0.469	1.113	0.438	0.63			1.27			0.59		
		Right Tilted	0.056	0.306	0.675	0.370	0.36			0.73			0.43		
		Left Cheek	0.134	0.469	1.113	0.165	0.60			1.25			0.30		
		Left Tilted	0.096	0.469	1.113	0.152	0.57			1.21			0.25		
WCDMA	Band V	Right Cheek	0.248	0.469	1.113	0.438	0.72			1.36			0.69		
		Right Tilted	0.177	0.306	0.675	0.370	0.48			0.85			0.55		
		Left Cheek	0.341	0.469	1.113	0.165	0.81			1.45			0.51		
		Left Tilted	0.188	0.469	1.113	0.152	0.66			1.30			0.34		
	Band II	Right Cheek	0.243	0.469	1.113	0.438	0.71			1.36			0.68		
		Right Tilted	0.096	0.306	0.675	0.370	0.40			0.77			0.47		
		Left Cheek	0.220	0.469	1.113	0.165	0.69			1.33			0.39		
		Left Tilted	0.159	0.469	1.113	0.152	0.63			1.27			0.31		
CDMA2000	BC0	Right Cheek	0.354	0.469	1.113	0.438	0.82			1.47			0.79		
		Right Tilted	0.189	0.306	0.675	0.370	0.50			0.86			0.56		
		Left Cheek	0.469	0.469	1.113	0.165	0.94			1.58			0.63		
		Left Tilted	0.204	0.469	1.113	0.152	0.67			1.32			0.36		
	BC1	Right Cheek	0.289	0.469	1.113	0.438	0.76			1.40			0.73		
		Right Tilted	0.109	0.306	0.675	0.370	0.42			0.78			0.48		
		Left Cheek	0.217	0.469	1.113	0.165	0.69			1.33			0.38		
		Left Tilted	0.170	0.469	1.113	0.152	0.64			1.28			0.32		



WWAN Band	Exposure Position	1	2	3	4	1+2			1+3			1+4			
		WWAN	2.4GHz WLAN	5GHz WLAN	Bluetooth	Summed 1g SAR (W/kg)	SPLSR	Case No	Summed 1g SAR (W/kg)	SPLSR	Case No	Summed 1g SAR (W/kg)	SPLSR	Case No	
		1g SAR (W/kg)	1g SAR (W/kg)	1g SAR (W/kg)	1g SAR (W/kg)	1g SAR (W/kg)			1g SAR (W/kg)			1g SAR (W/kg)			
LTE	Band 13	Right Cheek	0.227	0.469	1.113	0.438	0.70			1.34			0.67		
		Right Tilted	0.132	0.306	0.675	0.370	0.44			0.81			0.50		
		Left Cheek	0.262	0.469	1.113	0.165	0.73			1.38			0.43		
		Left Tilted	0.136	0.469	1.113	0.152	0.61			1.25			0.29		
	Band 5	Right Cheek	0.263	0.469	1.113	0.438	0.73			1.38			0.70		
		Right Tilted	0.135	0.306	0.675	0.370	0.44			0.81			0.51		
		Left Cheek	0.326	0.469	1.113	0.165	0.80			1.44			0.49		
		Left Tilted	0.159	0.469	1.113	0.152	0.63			1.27			0.31		
	Band 66	Right Cheek	0.570	0.469	1.113	0.438	1.04			1.68	0.02	#1	1.01		
		Right Tilted	0.175	0.306	0.675	0.370	0.48			0.85			0.55		
		Left Cheek	0.348	0.469	1.113	0.165	0.82			1.46			0.51		
		Left Tilted	0.217	0.469	1.113	0.152	0.69			1.33			0.37		
	Band 2	Right Cheek	0.316	0.469	1.113	0.438	0.79			1.43			0.75		
		Right Tilted	0.114	0.306	0.675	0.370	0.42			0.79			0.48		
		Left Cheek	0.256	0.469	1.113	0.165	0.73			1.37			0.42		
		Left Tilted	0.202	0.469	1.113	0.152	0.67			1.32			0.35		
	Band 7	Right Cheek	0.788	0.469	1.113	0.438	1.26			1.90	0.03	#2	1.23		
		Right Tilted	0.299	0.306	0.675	0.370	0.61			0.97			0.67		
		Left Cheek	0.427	0.469	1.113	0.165	0.90			1.54			0.59		
		Left Tilted	0.306	0.469	1.113	0.152	0.78			1.42			0.46		



16.2 Hotspot Exposure Conditions

WWAN Band	Exposure Position	1	2	3	4	1+2			1+3			1+4			
		WWAN	2.4GHz WLAN	5GHz WLAN	Bluetooth	Summed 1g SAR (W/kg)	SPLSR	Case No	Summed 1g SAR (W/kg)	SPLSR	Case No	Summed 1g SAR (W/kg)	SPLSR	Case No	
		1g SAR (W/kg)	1g SAR (W/kg)	1g SAR (W/kg)	1g SAR (W/kg)										
GSM	GSM850	Front	0.664	0.282	0.513	0.281	0.95			1.18			0.95		
		Back	0.916	0.367	0.815	0.315	1.28			1.73	0.02	#3	1.23		
		Left Side	0.369	0.367	0.912	0.228	0.74			1.28			0.60		
		Right Side	0.152				0.15			0.15			0.15		
		Top Side		0.367	0.912	0.088	0.37			0.91			0.09		
	Bottom Side	0.364				0.36			0.36			0.36			
	GSM1900	Front	0.361	0.282	0.513	0.281	0.64			0.87			0.64		
		Back	0.402	0.367	0.815	0.315	0.77			1.22			0.72		
		Left Side	0.016	0.367	0.912	0.228	0.38			0.93			0.24		
		Right Side	0.017				0.02			0.02			0.02		
Top Side			0.367	0.912	0.088	0.37			0.91			0.09			
Bottom Side	0.710				0.71			0.71			0.71				
WCDMA	Band V	Front	0.788	0.282	0.513	0.281	1.07			1.30			1.07		
		Back	1.178	0.367	0.815	0.315	1.55			1.99	0.02	#4	1.49		
		Left Side	0.367	0.367	0.912	0.228	0.73			1.28			0.60		
		Right Side	0.172				0.17			0.17			0.17		
		Top Side		0.367	0.912	0.088	0.37			0.91			0.09		
	Bottom Side	0.403				0.40			0.40			0.40			
	Band II	Front	0.514	0.282	0.513	0.281	0.80			1.03			0.80		
		Back	0.617	0.367	0.815	0.315	0.98			1.43			0.93		
		Left Side	0.022	0.367	0.912	0.228	0.39			0.93			0.25		
		Right Side	0.028				0.03			0.03			0.03		
Top Side			0.367	0.912	0.088	0.37			0.91			0.09			
Bottom Side	0.881				0.88			0.88			0.88				
CDMA2000	BC0	Front	0.564	0.282	0.513	0.281	0.85			1.08			0.85		
		Back	0.768	0.367	0.815	0.315	1.14			1.58			1.08		
		Left Side	0.314	0.367	0.912	0.228	0.68			1.23			0.54		
		Right Side	0.158				0.16			0.16			0.16		
		Top Side		0.367	0.912	0.088	0.37			0.91			0.09		
	Bottom Side	0.305				0.31			0.31			0.31			
	BC1	Front	0.463	0.282	0.513	0.281	0.75			0.98			0.74		
		Back	0.588	0.367	0.815	0.315	0.96			1.40			0.90		
		Left Side	0.017	0.367	0.912	0.228	0.38			0.93			0.25		
		Right Side	0.082				0.08			0.08			0.08		
Top Side			0.367	0.912	0.088	0.37			0.91			0.09			
Bottom Side	0.929				0.93			0.93			0.93				



WWAN Band	Exposure Position	1	2	3	4	1+2			1+3			1+4			
		WWAN	2.4GHz WLAN	5GHz WLAN	Bluetooth	Summed 1g SAR (W/kg)	SPLSR	Case No	Summed 1g SAR (W/kg)	SPLSR	Case No	Summed 1g SAR (W/kg)	SPLSR	Case No	
		1g SAR (W/kg)	1g SAR (W/kg)	1g SAR (W/kg)	1g SAR (W/kg)										
LTE	Band 13	Front	0.670	0.282	0.513	0.281	0.95			1.18			0.95		
		Back	0.880	0.367	0.815	0.315	1.25			1.70	0.01	#5	1.20		
		Left Side	0.382	0.367	0.912	0.228	0.75			1.29			0.61		
		Right Side	0.284				0.28			0.28			0.28		
		Top Side		0.367	0.912	0.088	0.37			0.91			0.09		
		Bottom Side	0.332				0.33			0.33			0.33		
	Band 5	Front	0.905	0.282	0.513	0.281	1.19			1.42			1.19		
		Back	1.177	0.367	0.815	0.315	1.54			1.99	0.02	#6	1.49		
		Left Side	0.330	0.367	0.912	0.228	0.70			1.24			0.56		
		Right Side	0.170				0.17			0.17			0.17		
		Top Side		0.367	0.912	0.088	0.37			0.91			0.09		
		Bottom Side	0.466				0.47			0.47			0.47		
	Band 66	Front	0.929	0.282	0.513	0.281	1.21			1.44			1.21		
		Back	0.959	0.367	0.815	0.315	1.33			1.77	0.02	#7	1.27		
		Left Side	0.079	0.367	0.912	0.228	0.45			0.99			0.31		
		Right Side	0.150				0.15			0.15			0.15		
		Top Side		0.367	0.912	0.088	0.37			0.91			0.09		
		Bottom Side	1.183				1.18			1.18			1.18		
	Band 2	Front	0.528	0.282	0.513	0.281	0.81			1.04			0.81		
		Back	0.649	0.367	0.815	0.315	1.02			1.46			0.96		
		Left Side	0.021	0.367	0.912	0.228	0.39			0.93			0.25		
		Right Side	0.064				0.06			0.06			0.06		
		Top Side		0.367	0.912	0.088	0.37			0.91			0.09		
		Bottom Side	0.875				0.88			0.88			0.88		
	Band 7	Front	0.387	0.282	0.513	0.281	0.67			0.90			0.67		
		Back	0.648	0.367	0.815	0.315	1.02			1.46			0.96		
		Left Side		0.367	0.912	0.228	0.37			0.91			0.23		
		Right Side	0.469				0.47			0.47			0.47		
		Top Side		0.367	0.912	0.088	0.37			0.91			0.09		
		Bottom Side	0.166				0.17			0.17			0.17		



**16.3 Body-Worn Accessory Exposure Conditions**

WWAN Band		Exposure Position	1	2	3	4	1+2			1+3			1+4		
			WWAN	2.4GHz WLAN	5GHz WLAN	Bluetooth	Summed 1g SAR (W/kg)	SPLSR	Case No	Summed 1g SAR (W/kg)	SPLSR	Case No	Summed 1g SAR (W/kg)	SPLSR	Case No
			1g SAR (W/kg)	1g SAR (W/kg)	1g SAR (W/kg)	1g SAR (W/kg)	1g SAR (W/kg)								
GSM	GSM850	Front	0.664	0.282	0.593	0.281	0.95			1.26			0.95		
		Back	0.916	0.367	1.158	0.315	1.28			2.07	0.02	#8	1.23		
	GSM1900	Front	0.361	0.282	0.593	0.281	0.64			0.95			0.64		
		Back	0.402	0.367	1.158	0.315	0.77			1.56			0.72		
WCDMA	Band V	Front	0.788	0.282	0.593	0.281	1.07			1.38			1.07		
		Back	1.178	0.367	1.158	0.315	1.55			2.34	0.02	#9	1.49		
	Band II	Front	1.066	0.282	0.593	0.281	1.35			1.66	0.01	#10	1.35		
		Back	1.134	0.367	1.158	0.315	1.50			2.29	0.02	#11	1.45		
CDMA2000	BC0	Front	0.690	0.282	0.593	0.281	0.97			1.28			0.97		
		Back	0.831	0.367	1.158	0.315	1.20			1.99	0.02	#12	1.15		
	BC1	Front	1.041	0.282	0.593	0.281	1.32			1.63	0.01	#13	1.32		
		Back	1.160	0.367	1.158	0.315	1.53			2.32	0.02	#14	1.48		
LTE	Band 13	Front	0.670	0.282	0.593	0.281	0.95			1.26			0.95		
		Back	0.880	0.367	1.158	0.315	1.25			2.04	0.02	#15	1.20		
	Band 5	Front	0.905	0.282	0.593	0.281	1.19			1.50			1.19		
		Back	1.177	0.367	1.158	0.315	1.54			2.34	0.02	#16	1.49		
	Band 66	Front	1.168	0.282	0.593	0.281	1.45			1.76	0.01	#17	1.45		
		Back	1.168	0.367	1.158	0.315	1.54			2.33	0.02	#18	1.48		
	Band 2	Front	0.910	0.282	0.593	0.281	1.19			1.50			0.81		
		Back	1.125	0.367	1.158	0.315	1.49			2.28	0.02	#19	0.96		
	Band 7	Front	0.387	0.282	0.593	0.281	0.67			0.98			0.67		
		Back	0.648	0.367	1.158	0.315	1.02			1.81	0.02	#20	0.96		



**16.4 Product specific 10g SAR Exposure Conditions**

WWAN Band		Exposure Position	1	2	1+2		
			WWAN	5GHz WLAN	Summed 10g SAR (W/kg)	SPLSR	Case No
			10g SAR (W/kg)	10g SAR (W/kg)			
GSM	GSM850	Back	0.833	0.515	1.35		
	GSM1900	Front	1.853	1.090	2.94		
		Back	3.392	0.515	3.91		
		Bottom side	1.391		1.39		
WCDMA	Band V	Front	0.546	1.090	1.64		
		Back	0.665	0.515	1.18		
	Band II	Front	2.764	1.090	3.85		
		Back	3.363	0.515	3.88		
		Bottom side	1.633		1.63		
	CDMA2000	BC0	Front	2.819	1.090	3.91	
Back			3.253	0.515	3.77		
BC1		Front	2.210	1.090	3.30		
		Back	2.756	0.515	3.27		
		Bottom side	1.430		1.43		
LTE	Band 13	Back	2.405	0.515	2.92		
	Band 5	Front	2.153	1.090	3.24		
		Back	2.921	0.515	3.44		
	Band 66	Front	2.873	1.090	3.96		
		Back	3.315	0.515	3.83		
		Bottom side	2.145		2.15		
	Band 2	Front	2.887	1.090	3.98		
		Back	3.480	0.515	4.00	0.05	#21
		Bottom side	2.550		2.55		
	Band 7	Front	2.202	1.090	3.29		
		Back	3.469	0.515	3.98		
Right Side		2.424		2.42			

**Remark:**

1. For Bluetooth/WLAN 2.4GHz Product specific 10g stand-alone SAR is not required for a transmitter or antenna, due to 1g hotspot SAR is <1.2W/kg.
2. SPLSR ≤ 0.10 for 10g SAR, simultaneously transmission SAR measurement is not necessary.

**16.5 SPLSR Evaluation and Analysis**

**General Note:**

- When standalone SAR is measured for both antennas in the pair, the peak location separation distance is computed by the square root of  $[(x1-x2)^2 + (y1-y2)^2 + (z1-z2)^2]$ , where (x1, y1, z1) and (x2, y2, z2) are the coordinates in the area scans or extrapolated peak SAR locations in the zoom scans, as appropriate.
- $SPLSR = (SAR_1 + SAR_2)^{1.5} / (min. \text{ separation distance, mm})$ . If  $SPLSR \leq 0.04$  for 1g SAR and  $SPLSR \leq 0.10$  for 10g SAR, simultaneously transmission SAR measurement is not necessary.

Case #1	Band	Position	1g SAR (W/kg)	Gap (mm)	SAR peak location (cm)			3D distance (mm)	Summed 1g SAR (W/kg)	SPLSR Results	Simultaneous SAR
					X	Y	Z				
	LTE Band 66	Right Cheek	0.570	0	3.92	6.83	-0.08	104.6	1.68	0.02	Not required
	WLAN5GHz		1.113	0	0.94	-3.2	-0.1				

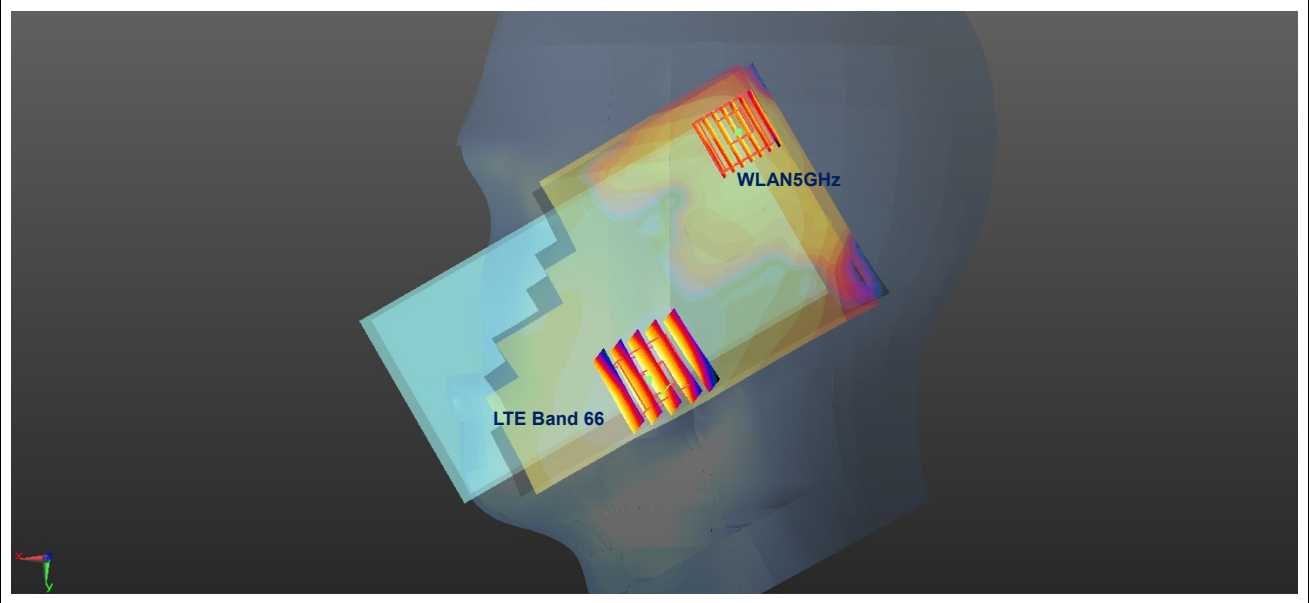

Case #2	Band	Position	1g SAR (W/kg)	Gap (mm)	SAR peak location (cm)			3D distance (mm)	Summed 1g SAR (W/kg)	SPLSR Results	Simultaneous SAR
					X	Y	Z				
	LTE Band 7	Right Cheek	0.788	0	3.16	6.85	-0.14	102.9	1.90	0.03	Not required
	WLAN5GHz		1.113	0	0.94	-3.2	-0.1				

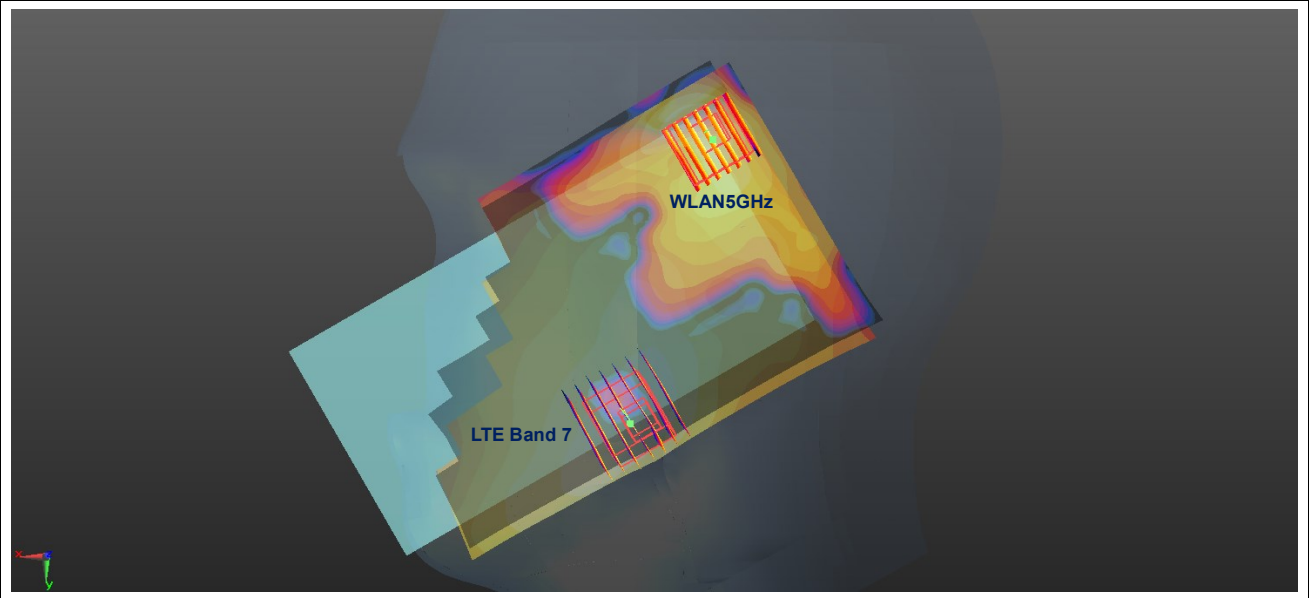



Case #3	Band	Position	1g SAR (W/kg)	Gap (mm)	SAR peak location (cm)			3D distance (mm)	Summed 1g SAR (W/kg)	SPLSR Results	Simultaneous SAR
	GSM850				WLAN5GHz	X	Y				
	GSM850	Back	0.916	5	-1.82	-7.67	-0.14	148.7	1.73	0.02	Not required
	WLAN5GHz		0.815	5	2.08	6.68	-0.1				

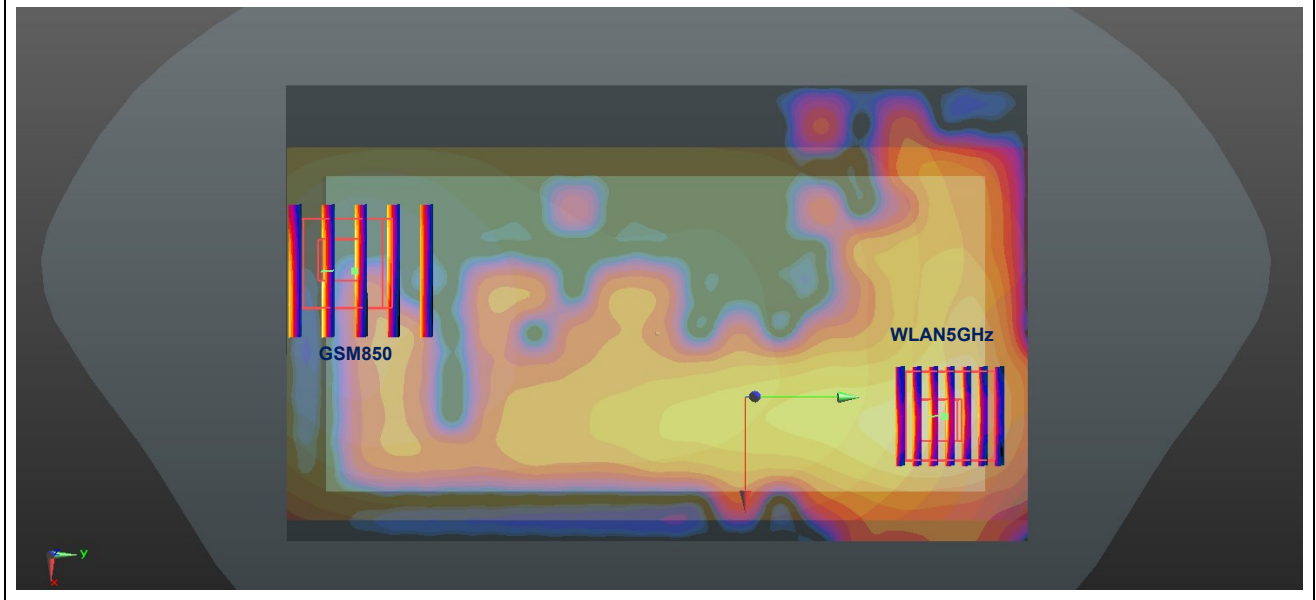

Case #4	Band	Position	1g SAR (W/kg)	Gap (mm)	SAR peak location (cm)			3D distance (mm)	Summed 1g SAR (W/kg)	SPLSR Results	Simultaneous SAR
	WCDMA Band V				WLAN5GHz	X	Y				
	WCDMA Band V	Back	1.178	5	-1.99	-7.35	-0.15	146.1	1.99	0.02	Not required
	WLAN5GHz		0.815	5	2.08	6.68	-0.1				

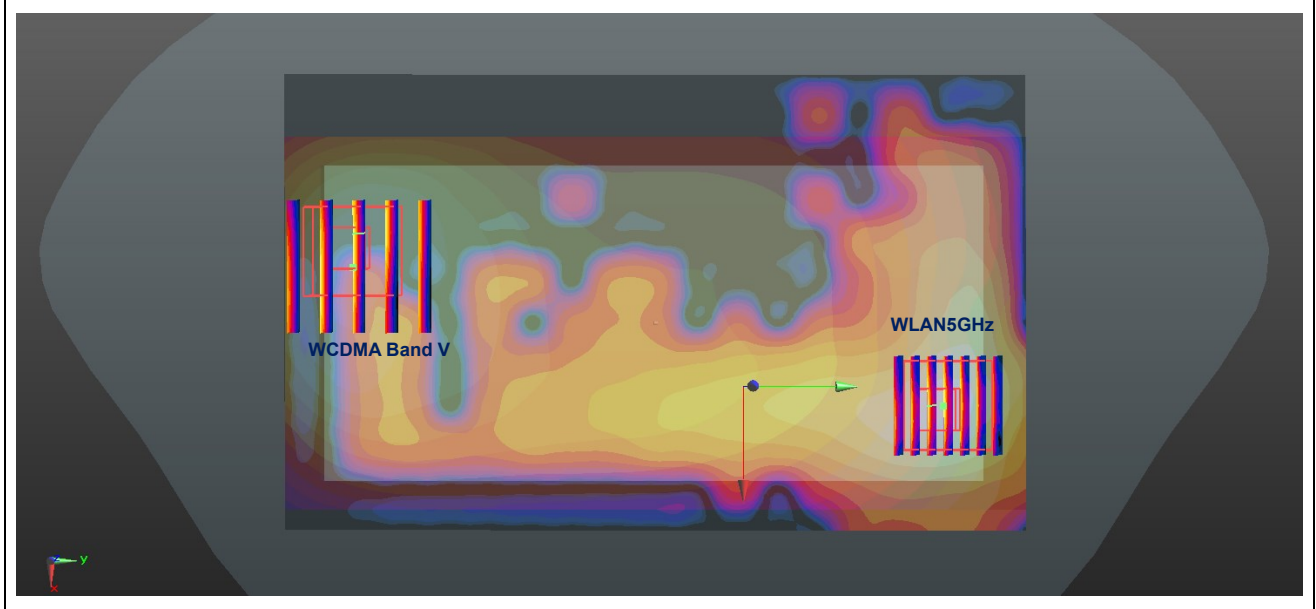

Case #5	Band	Position	1g SAR (W/kg)	Gap (mm)	SAR peak location (cm)			3D distance (mm)	Summed 1g SAR (W/kg)	SPLSR Results	Simultaneous SAR
					X	Y	Z				
	LTE Band 13	Back	0.880	5	-1.46	-8.14	-0.13	152.4	1.70	0.01	Not required
	WLAN5GHz		0.815	5	2.08	6.68	-0.1				

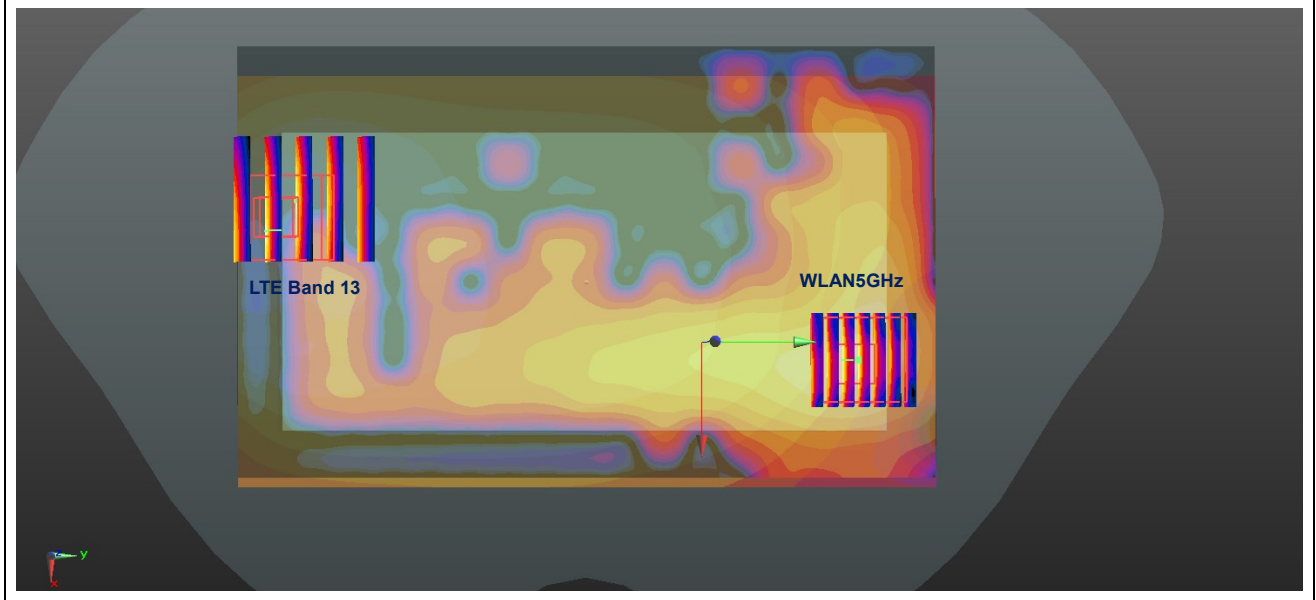

Case #6	Band	Position	1g SAR (W/kg)	Gap (mm)	SAR peak location (cm)			3D distance (mm)	Summed 1g SAR (W/kg)	SPLSR Results	Simultaneous SAR
					X	Y	Z				
	LTE Band 5	Back	1.177	5	-1.98	-7.51	-0.15	147.6	1.99	0.02	Not required
	WLAN5GHz		0.815	5	2.08	6.68	-0.1				

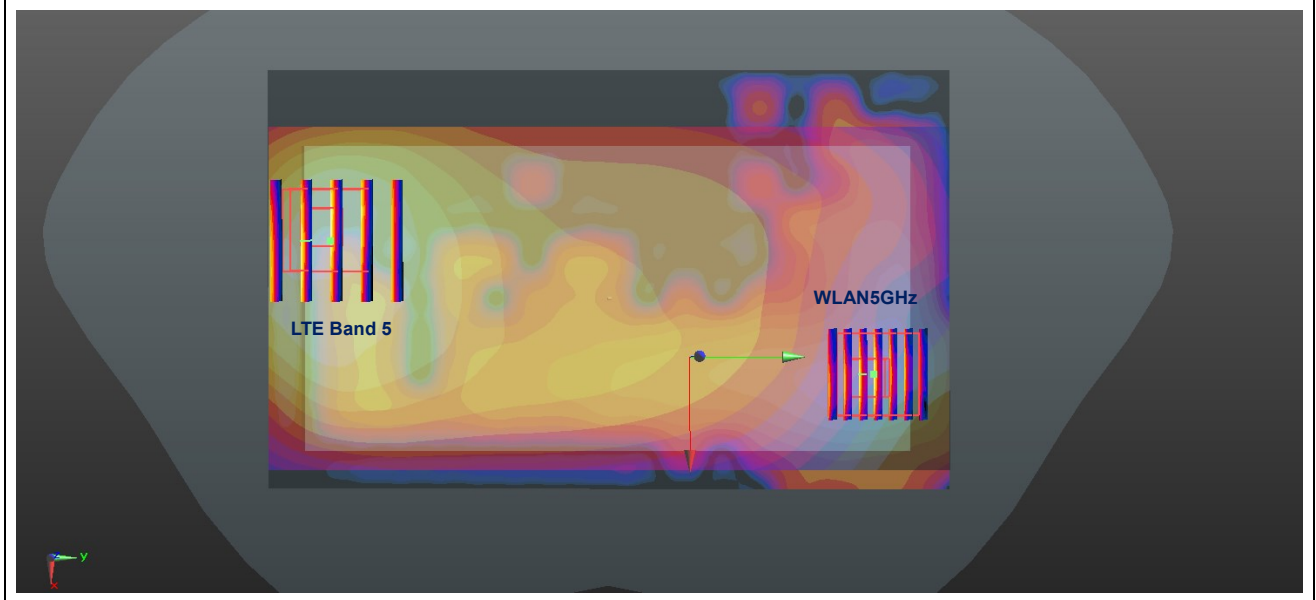

Case #7	Band	Position	1g SAR (W/kg)	Gap (mm)	SAR peak location (cm)			3D distance (mm)	Summed 1g SAR (W/kg)	SPLSR Results	Simultaneous SAR
					X	Y	Z				
	LTE Band 66	Back	0.959	5	-1.38	-8.23	-0.11	153.1	1.77	0.02	Not required
	WLAN5GHz		0.815	5	2.08	6.68	-0.1				

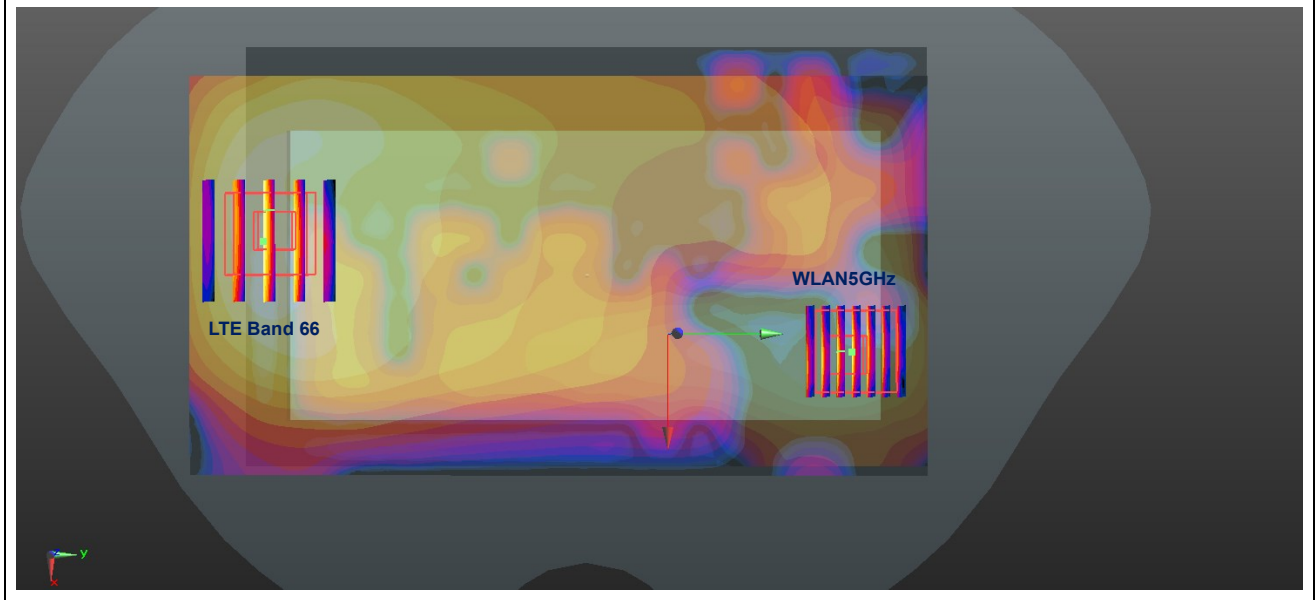

Case #8	Band	Position	1g SAR (W/kg)	Gap (mm)	SAR peak location (cm)			3D distance (mm)	Summed 1g SAR (W/kg)	SPLSR Results	Simultaneous SAR
					X	Y	Z				
	GSM850	Back	0.916	5	-1.82	-7.67	-0.14	148.2	2.07	0.02	Not required
	WLAN5GHz		1.158	5	1.9	6.68	-0.1				

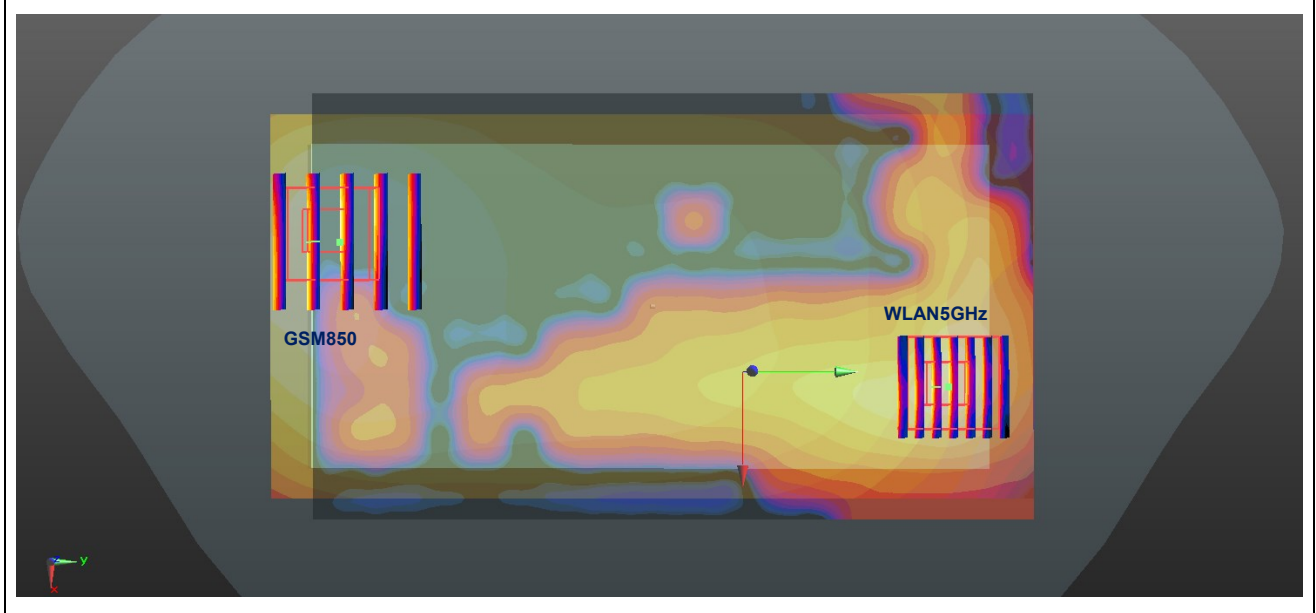

Case #9	Band	Position	1g SAR (W/kg)	Gap (mm)	SAR peak location (cm)			3D distance (mm)	Summed 1g SAR (W/kg)	SPLSR Results	Simultaneous SAR
					X	Y	Z				
	WCDMA Band V	Back	1.178	5	-1.99	-7.35	-0.15	145.6	2.34	0.02	Not required
	WLAN5GHz		1.158	5	1.9	6.68	-0.1				

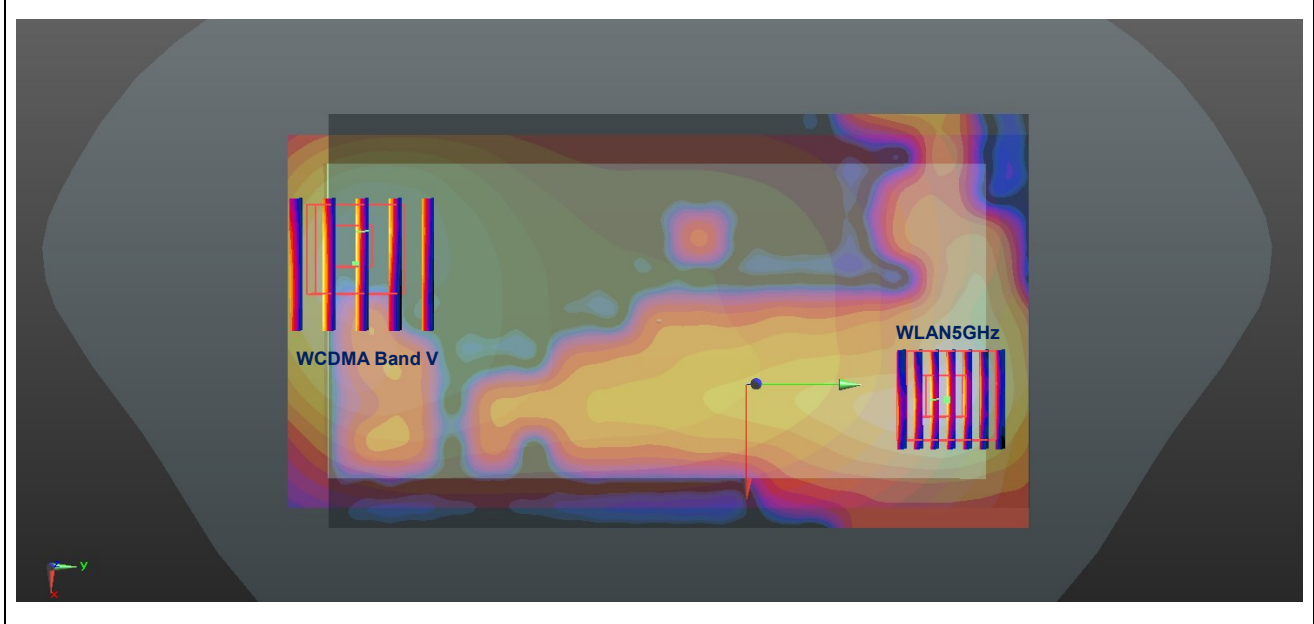

Case #10	Band	Position	1g SAR (W/kg)	Gap (mm)	SAR peak location (cm)			3D distance (mm)	Summed 1g SAR (W/kg)	SPLSR Results	Simultaneous SAR
					X	Y	Z				
	WCDMA Band II	Front	1.066	5	0.45	-7.81	-0.114	161.0	1.66	0.01	Not required
	WLAN5GHz		0.593	5	-5.26	7.24	-0.12				

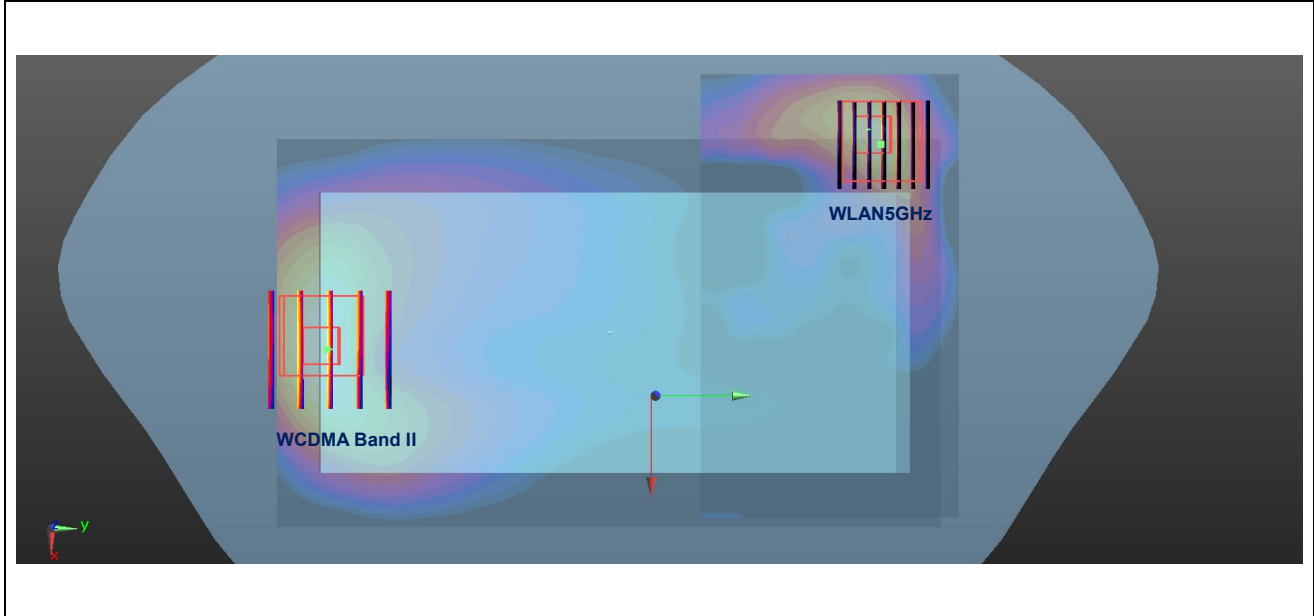

Case #11	Band	Position	1g SAR (W/kg)	Gap (mm)	SAR peak location (cm)			3D distance (mm)	Summed 1g SAR (W/kg)	SPLSR Results	Simultaneous SAR
					X	Y	Z				
	WCDMA Band II	Back	1.134	5	-1.7	-7.98	-0.124	151.0	2.29	0.02	Not required
	WLAN5GHz		1.158	5	1.9	6.68	-0.1				

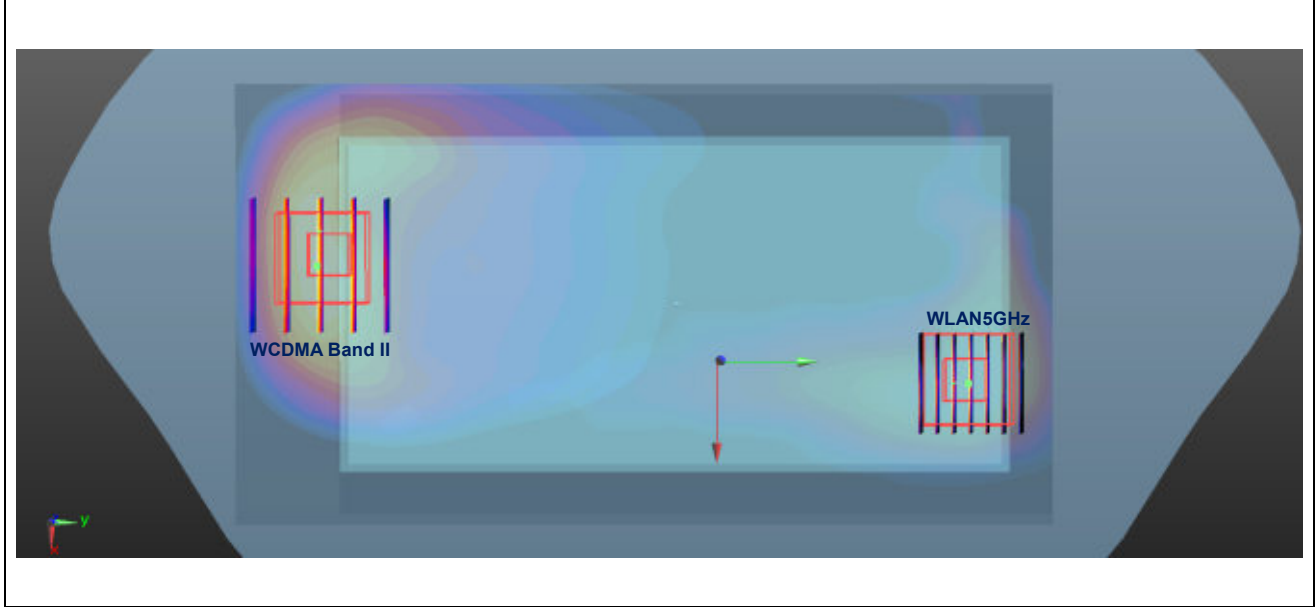

Case #12	Band	Position	1g SAR (W/kg)	Gap (mm)	SAR peak location (cm)			3D distance (mm)	Summed 1g SAR (W/kg)	SPLSR Results	Simultaneous SAR
					X	Y	Z				
	CDMA2000 BC0	Back	0.831	5	-1.5	-7.99	-0.13	150.6	1.99	0.02	Not required
	WLAN5GHz		1.158	5	1.9	6.68	-0.1				

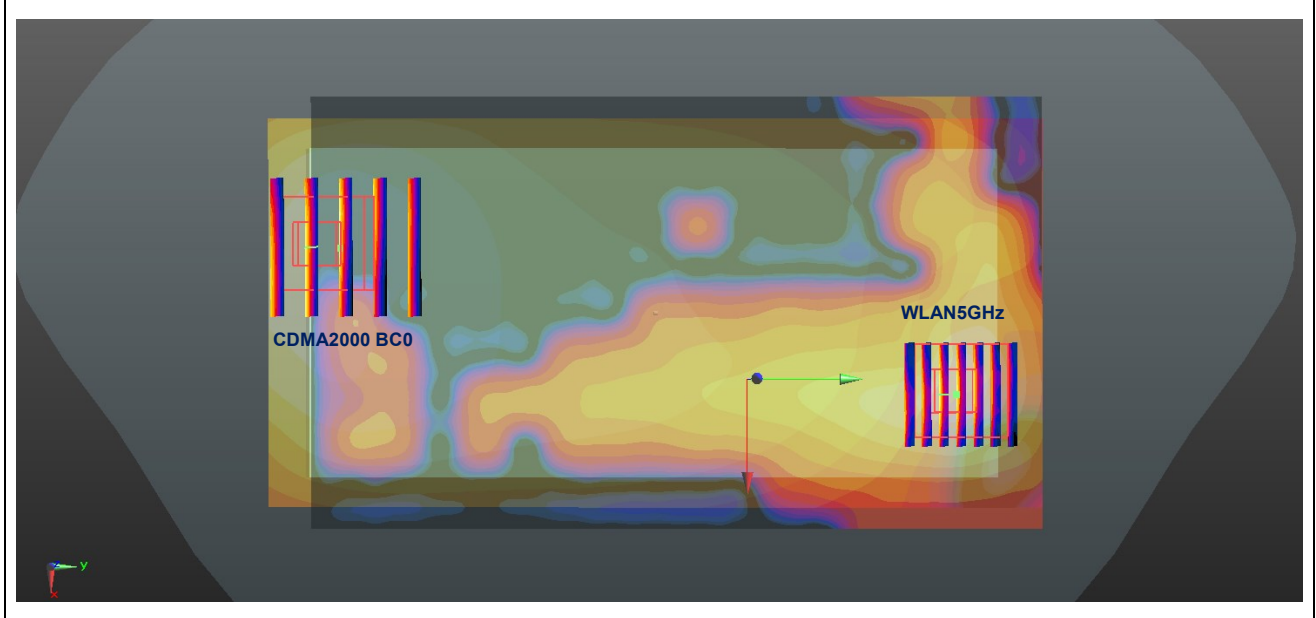

Case #13	Band	Position	1g SAR (W/kg)	Gap (mm)	SAR peak location (cm)			3D distance (mm)	Summed 1g SAR (W/kg)	SPLSR Results	Simultaneous SAR
					X	Y	Z				
	CDMA2000 BC1	Front	1.041	5	0.46	-7.95	-0.105	162.3	1.63	0.01	Not required
	WLAN5GHz		0.593	5	-5.26	7.24	-0.12				

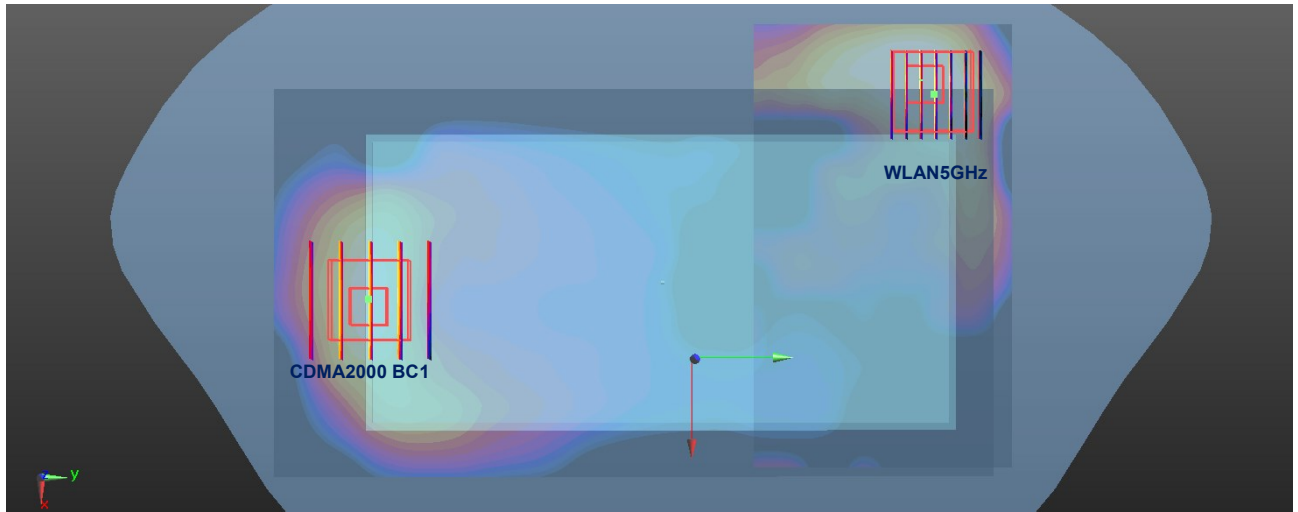

Case #14	Band	Position	1g SAR (W/kg)	Gap (mm)	SAR peak location (cm)			3D distance (mm)	Summed 1g SAR (W/kg)	SPLSR Results	Simultaneous SAR
					X	Y	Z				
	CDMA2000 BC1	Back	1.160	5	-1.7	-7.81	-0.127	149.3	2.32	0.02	Not required
	WLAN5GHz		1.158	5	1.9	6.68	-0.1				

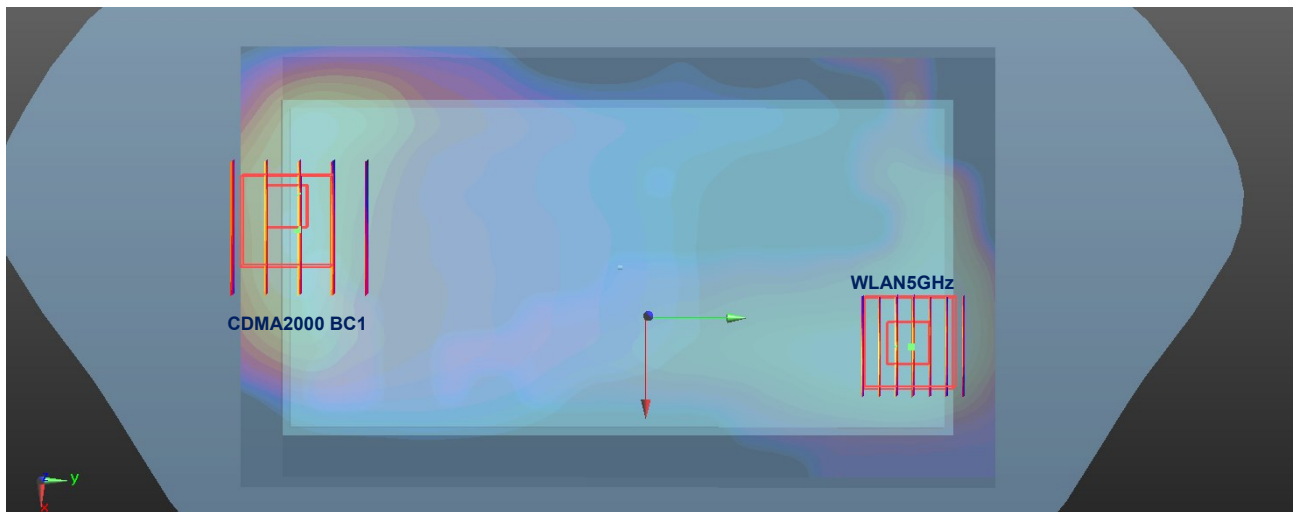

Case #15	Band	Position	1g SAR (W/kg)	Gap (mm)	SAR peak location (cm)			3D distance (mm)	Summed 1g SAR (W/kg)	SPLSR Results	Simultaneous SAR
					X	Y	Z				
	LTE Band 13	Back	0.880	5	-1.46	-8.14	-0.13	152.0	2.04	0.02	Not required
	WLAN5GHz		1.158	5	1.9	6.68	-0.1				

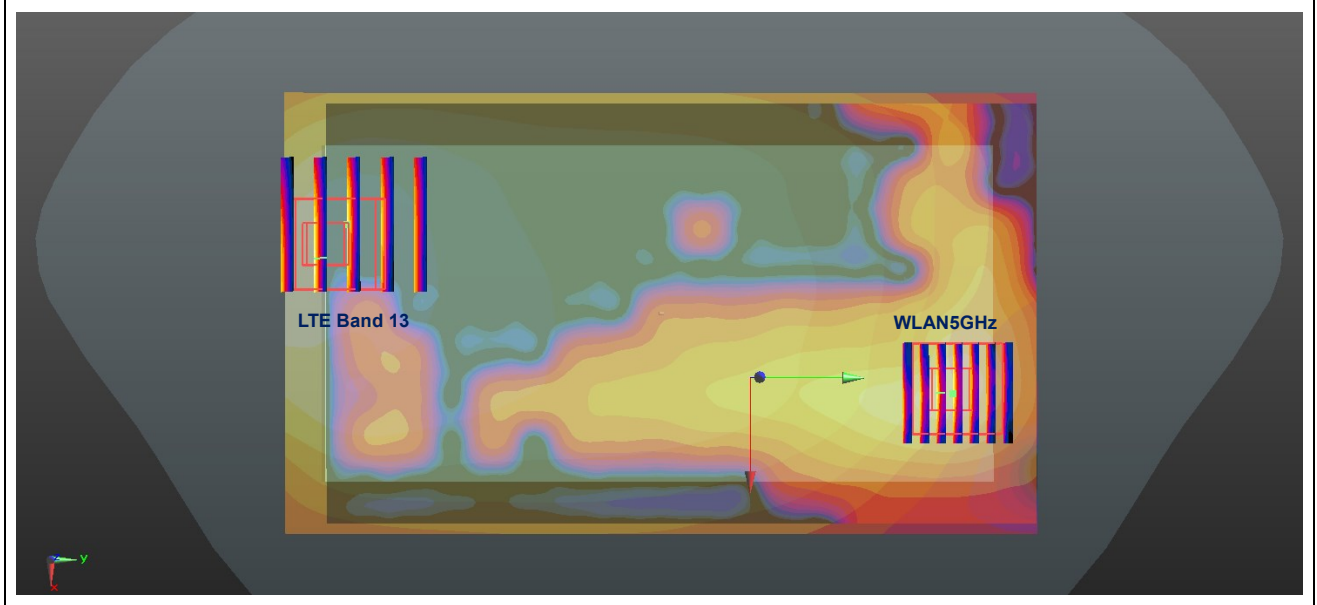

Case #16	Band	Position	1g SAR (W/kg)	Gap (mm)	SAR peak location (cm)			3D distance (mm)	Summed 1g SAR (W/kg)	SPLSR Results	Simultaneous SAR
					X	Y	Z				
	LTE Band 5	Back	1.177	5	-1.98	-7.51	-0.15	147.1	2.34	0.02	Not required
	WLAN5GHz		1.158	5	1.9	6.68	-0.1				

