



FCC RF Test Report

APPLICANT : Motorola Mobility LLC
EQUIPMENT : Mobile Cellular Phone
BRAND NAME : Motorola
MODEL NAME : XT1922-5, XT1922-4
FCC ID : IHDT56XB5
STANDARD : FCC 47 CFR Part 2, 22(H), 24(E), 27(L)
CLASSIFICATION : PCS Licensed Transmitter Held to Ear (PCE)

The product was received on Dec. 05, 2017 and testing was completed on Dec. 09, 2017. We, Sporton International (Kunshan) Inc., would like to declare that the tested sample has been evaluated in accordance with the test procedures given in ANSI/TIA-603-E and has been in compliance with the applicable technical standards.

The test results in this report apply exclusively to the tested model / sample. Without written approval of Sporton International (Kunshan) Inc., the test report shall not be reproduced except in full.



Approved by: James Huang / Manager

Sporton International (Kunshan) Inc.
No.3-2 Ping-Xiang Rd, Kunshan Development Zone Kunshan City Jiangsu Province 215335
China



TABLE OF CONTENTS

REVISION HISTORY.....3

SUMMARY OF TEST RESULT4

1 GENERAL DESCRIPTION5

1.1 Applicant.....5

1.2 Manufacturer5

1.3 Product Feature of Equipment Under Test5

1.4 Product Specification of Equipment Under Test6

1.5 Specification of Accessory7

1.6 Modification of EUT8

1.7 Maximum ERP/EIRP Power, Frequency Tolerance, and Emission Designator8

1.8 Testing Location9

1.9 Applicable Standards9

2 TEST CONFIGURATION OF EQUIPMENT UNDER TEST10

2.1 Test Mode.....10

2.2 Connection Diagram of Test System11

2.3 Support Unit used in test configuration12

2.4 Measurement Results Explanation Example12

3 CONDUCTED TEST RESULT.....13

3.1 Measuring Instruments.....13

3.2 Test Setup13

3.3 Test Result of Conducted Test.....13

3.4 Conducted Output Power and ERP/EIRP14

3.5 Peak-to-Average Ratio15

3.6 99% Occupied Bandwidth and 26dB Bandwidth Measurement.....16

3.7 Conducted Band Edge17

3.8 Conducted Spurious Emission18

3.9 Frequency Stability.....19

4 RADIATED TEST ITEMS20

4.1 Measuring Instruments.....20

4.2 Test Setup20

4.3 Test Result of Radiated Test.....20

4.4 Field Strength of Spurious Radiation Measurement21

5 LIST OF MEASURING EQUIPMENT22

6 UNCERTAINTY OF EVALUATION23

APPENDIX A. TEST RESULTS OF CONDUCTED TEST

APPENDIX B. TEST RESULTS OF RADIATED TEST

APPENDIX C. TEST SETUP PHOTOGRAPHS



SUMMARY OF TEST RESULT

Report Section	FCC Rule	Description	Limit	Result	Remark
3.4	§2.1046	Conducted Output Power	Reporting Only	PASS	-
	§22.913(a)(2)	Effective Radiated Power	< 7 Watts	PASS	-
	§24.232(c)	Equivalent Isotropic Radiated Power	< 2 Watts	PASS	-
	§27.50(d)(4)	Equivalent Isotropic Radiated Power	< 1 Watts	PASS	-
3.5	§24.232(d)	Peak-to-Average Ratio	< 13 dB	PASS	-
3.6	§2.1049 §22.917(b) §24.238(b) §27.53(g)	Occupied Bandwidth	Reporting Only	PASS	-
3.7	§2.1051 §22.917(a) §24.238(a) §27.53(h)	Band Edge Measurement	< 43+10log10(P[Watts])	PASS	-
3.8	§2.1051 §22.917(a) §24.238(a) §27.53(h)	Conducted Emission	< 43+10log10(P[Watts])	PASS	-
3.9	§2.1055 §22.355	Frequency Stability for Temperature & Voltage	< 2.5 ppm for Part 22H	PASS	-
	§2.1055 §24.235		Within Authorized Band		
4.4	§2.1053 §22.917(a) §24.238(a) §27.53(h)	Field Strength of Spurious Radiation	< 43+10log10(P[Watts])	PASS	Under limit 27.30 dB at 3759.00 MHz



1 General Description

1.1 Applicant

Motorola Mobility LLC
222 W,Merchandise Mart Plaza, Chicago IL 60654 USA

1.2 Manufacturer

Motorola Mobility LLC
222 W,Merchandise Mart Plaza, Chicago IL 60654 USA

1.3 Product Feature of Equipment Under Test

Product Feature	
Equipment	Mobile Cellular Phone
Brand Name	Motorola
Model Name	XT1922-5, XT1922-4
FCC ID	IHDT56XB5
EUT supports Radios application	GSM/GPRS/EGPRS/WCDMA/HSPA/DC-HSDPA/ HSPA+(16QAM uplink is not supported)/LTE/ WLAN 2.4GHz 802.11b/g/n HT20/ Bluetooth v3.0 + EDR/ Bluetooth v 4.0 LE/ Bluetooth v4.1 LE/ Bluetooth v4.2 LE/
IMEI Code	Conducted: 3591842090038738/351842090038746 Radiation: 351842090040031/351842090040049
HW Version	DVT1B
SW Version	fastboot_aljeter_oem_userdebug_8.0.0_OPP27.38_1080_in tcfg-test-keys
EUT Stage	Identical Prototype

Remark:

1. The above EUT's information was declared by manufacturer. Please refer to the specifications or user's manual for more detailed description.
2. There are two types of EUT, the only difference between two samples is SIM slot: sample 1(Model: XT1922-5) is dual SIM slot, sample 2(Model: XT1922-4) is single SIM slot. Based on the similarity between two samples, we only choose sample 1 to perform RF test.



1.4 Product Specification of Equipment Under Test

Standards-related Product Specification	
Tx Frequency	GSM/GPRS/EDGE: 850: 824.2 MHz ~ 848.8 MHz 1900: 1850.2 MHz ~ 1909.8MHz WCDMA: Band V: 826.4 MHz ~ 846.6 MHz Band II: 1852.4 MHz ~ 1907.6 MHz Band IV: 1712.4 MHz ~ 1752.6 MHz
Rx Frequency	GSM/GPRS/EDGE: 850: 869.2 MHz ~ 893.8 MHz 1900: 1930.2 MHz ~ 1989.8 MHz WCDMA: Band V: 871.4 MHz ~ 891.6 MHz Band II: 1932.4 MHz ~ 1987.6 MHz Band IV: 2112.4 MHz ~ 2152.6 MHz
Maximum Output Power to Antenna	GSM/GPRS/EDGE: 850: 32.80 dBm 1900: 30.03 dBm WCDMA: Band V: 23.22 dBm Band II: 23.20 dBm Band IV: 22.99 dBm
Antenna Type	LDS Antenna
Antenna Gain	Cellular Band: -3.05 dBi PCS Band: 2.1 dBi AWS Band: 2.04 dBi
Type of Modulation	GSM: GMSK GPRS: GMSK EDGE: GMSK / 8PSK WCDMA: BPSK (Uplink) HSDPA/DC-HSDPA : QPSK (Uplink) HSUPA: QPSK (Uplink) DC-HSDPA : 64QAM HSPA+ : 16QAM (uplink is not supported)



1.5 Specification of Accessory

Specification of Accessory			
AC Adapter 1(US)	Brand Name	Motorola (Salom)	Model Name SC-22 SPN5970A
	Power Rating	I/P: 100-240 Vac, 500mA, O/P: 5Vdc,3000mA or 9Vdc,1600mA or 12Vdc,1200mA	
AC Adapter 1(EU)	Brand Name	Motorola (Salom)	Model Name SC-23 SPN5971A
	Power Rating	I/P: 100-240 Vac, 500mA, O/P: 5Vdc,3000mA or 9Vdc,1600mA or 12Vdc,1200mA	
AC Adapter 1(UK)	Brand Name	Motorola (Salom)	Model Name SC-24 SPN5972A
	Power Rating	I/P: 100-240 Vac, 500mA, O/P: 5Vdc,3000mA or 9Vdc,1600mA or 12Vdc,1200mA	
AC Adapter 1(IN)	Brand Name	Motorola (Salom)	Model Name SC-25 SPN5973A
	Power Rating	I/P: 100-240 Vac, 500mA, O/P: 5Vdc,3000mA or 9Vdc,1600mA or 12Vdc,1200mA	
AC Adapter 1(AU)	Brand Name	Motorola (Salom)	Model Name SC-26 SPN5974A
	Power Rating	I/P: 100-240 Vac, 500mA, O/P: 5Vdc,3000mA or 9Vdc,1600mA or 12Vdc,1200mA	
AC Adapter 1(AR)	Brand Name	Motorola (Salom)	Model Name SC-27 SPN5975A
	Power Rating	I/P: 100-240 Vac, 500mA, O/P: 5Vdc,3000mA or 9Vdc,1600mA or 12Vdc,1200mA	
AC Adapter 1(BR)	Brand Name	Motorola (Salom)	Model Name SC-28 SPN5976A
	Power Rating	I/P: 100-240 Vac, 500mA, O/P: 5Vdc,3000mA or 9Vdc,1600mA or 12Vdc,1200mA	
AC Adapter 1(BR)	Brand Name	Motorola (Salom)	Model Name SC-28 SPN5997A
	Power Rating	I/P: 100-240 Vac, 500mA, O/P: 5Vdc,3000mA or 9Vdc,1600mA or 12Vdc,1200mA	
AC Adapter 2(US)	Brand Name	Motorola (Chenyang)	Model Name SC-22 SPN5993A
	Power Rating	I/P: 100-240 Vac, 500mA, O/P: 5Vdc,3000mA or 9Vdc,1600mA or 12Vdc,1200mA	
AC Adapter 2(EU)	Brand Name	Motorola (Chenyang)	Model Name SC-23 SPN5989A
	Power Rating	I/P: 100-240 Vac, 500mA, O/P: 5Vdc,3000mA or 9Vdc,1600mA or 12Vdc,1200mA	
AC Adapter 2(UK)	Brand Name	Motorola (Chenyang)	Model Name SC-24 SPN5990A
	Power Rating	I/P: 100-240 Vac, 500mA, O/P: 5Vdc,3000mA or 9Vdc,1600mA or 12Vdc,1200mA	
AC Adapter 2(IN)	Brand Name	Motorola (Chenyang)	Model Name SC-25 SPN5991A
	Power Rating	I/P: 100-240 Vac, 500mA, O/P: 5Vdc,3000mA or 9Vdc,1600mA or 12Vdc,1200mA	
AC Adapter 2(AU)	Brand Name	Motorola (Chenyang)	Model Name SC-26 SPN5988A
	Power Rating	I/P: 100-240 Vac, 500mA, O/P: 5Vdc,3000mA or 9Vdc,1600mA or 12Vdc,1200mA	
AC Adapter 2(AR)	Brand Name	Motorola (Chenyang)	Model Name SC-27 SPN5992A
	Power Rating	I/P: 100-240 Vac, 500mA, O/P: 5Vdc,3000mA or 9Vdc,1600mA or 12Vdc,1200mA	



AC Adapter 3(BR)	Brand Name	Motorola (Cliptech)	Model Name	SC-28 SPN5998A
	Power Rating	I/P: 100-240 Vac, 500mA, O/P: 5Vdc,3000mA or 9Vdc,1600mA or 12Vdc,1200mA		
Battery	Brand Name	Lenovo (SCUD)	Model Name	BL270
	Power Rating	3.85/4.4Vdc,4000mAh	Type	Li-ion
Earphone	Brand Name	Motorola(NEW LEADER)	Model Name	NLD-EM307E-02SF
	Signal Line Type	1.2 meter, non-shielded cable, without ferrite core		
USB Cable	Brand Name	Motorola (Saibao)	Model Name	SLQ-A077A
	Signal Line Type	1.0 meter, shielded cable, without ferrite core		

1.6 Modification of EUT

No modifications are made to the EUT during all test items.

1.7 Maximum ERP/EIRP Power, Frequency Tolerance, and Emission Designator

FCC Rule	System	Type of Modulation	Maximum ERP/EIRP (W)	Frequency Tolerance (ppm)	Emission Designator
Part 22H	GSM850 GSM	GMSK	0.5754	0.0203 ppm	242KGXW
Part 22H	GSM850 EDGE class 8	8PSK	0.1384	0.0275 ppm	246KG7W
Part 22H	WCDMA Band V RMC 12.2Kbps	BPSK	0.0634	0.0359 ppm	4M12F9W
Part 24E	GSM1900 GSM	GMSK	1.6331	0.0133 ppm	244KGXW
Part 24E	GSM1900 EDGE class 8	8PSK	0.6180	0.0181 ppm	248KG7W
Part 24E	WCDMA Band II RMC 12.2Kbps	BPSK	0.3388	0.0165 ppm	4M12F9W
Part 27L	WCDMA Band IV RMC 12.2Kbps	BPSK	0.3184	0.0150 ppm	4M13F9W



1.8 Testing Location

Sporton International (Kunshan) Inc. is accredited to ISO 17025 by National Voluntary Laboratory Accreditation Program (NVLAP code: 600155-0) and the FCC designation No. is CN5013.

Test Site	Sporton International (Kunshan) Inc.		
Test Site Location	No.3-2 Ping-Xiang Rd, Kunshan Development Zone Kunshan City Jiangsu Province 215335 China TEL: +86-512-57900158 FAX: +86-512-57900958		
Test Site No.	Sporton Site No.		FCC Test Firm Registration No.
	TH01-KS	03CH03-KS	630927

Note: The test site complies with ANSI C63.4 2014 requirement.

1.9 Applicable Standards

According to the specifications of the manufacturer, the EUT must comply with the requirements of the following standards:

- ♦ 47 CFR Part 2, 22(H), 24(E), 27(L)
- ♦ ANSI/TIA-603-E
- ♦ FCC KDB 971168 D01 Power Meas. License Digital Systems v03
- ♦ FCC KDB 412172 D01 Determining ERP and EIRP v01r01

Remark:

1. All test items were verified and recorded according to the standards and without any deviation during the test.
2. This EUT has also been tested and complied with the requirements of FCC Part 15, Subpart B, recorded in a separate test report.



2 Test Configuration of Equipment Under Test

2.1 Test Mode

Antenna port conducted and radiated test items were performed according to KDB 971168 D01 Power Meas. License Digital Systems v03 with maximum output power.

Radiated measurements were performed with rotating EUT in different three orthogonal test planes to find the maximum emission.

Radiated emissions were investigated as following frequency range:

1. 30 MHz to 10th harmonic for GSM850 and WCDMA Band V.
2. 30 MHz to 10th harmonic for WCDMA Band IV.
3. 30 MHz to 10th harmonic for GSM1900 and WCDMA Band II.

All modes and data rates and positions were investigated.

Test modes are chosen to be reported as the worst case configuration below:

Test Modes		
Band	Radiated TCs	Conducted TCs
GSM 850	<ul style="list-style-type: none"> ■ GSM Link ■ EDGE class 8 Link 	<ul style="list-style-type: none"> ■ GSM Link ■ EDGE class 8 Link
GSM 1900	<ul style="list-style-type: none"> ■ GSM Link ■ EDGE class 8 Link 	<ul style="list-style-type: none"> ■ GSM Link ■ EDGE class 8 Link
WCDMA Band V	<ul style="list-style-type: none"> ■ RMC 12.2Kbps Link 	<ul style="list-style-type: none"> ■ RMC 12.2Kbps Link
WCDMA Band II	<ul style="list-style-type: none"> ■ RMC 12.2Kbps Link 	<ul style="list-style-type: none"> ■ RMC 12.2Kbps Link
WCDMA Band IV	<ul style="list-style-type: none"> ■ RMC 12.2Kbps Link 	<ul style="list-style-type: none"> ■ RMC 12.2Kbps Link

2.2 Connection Diagram of Test System

For 22H, 24E

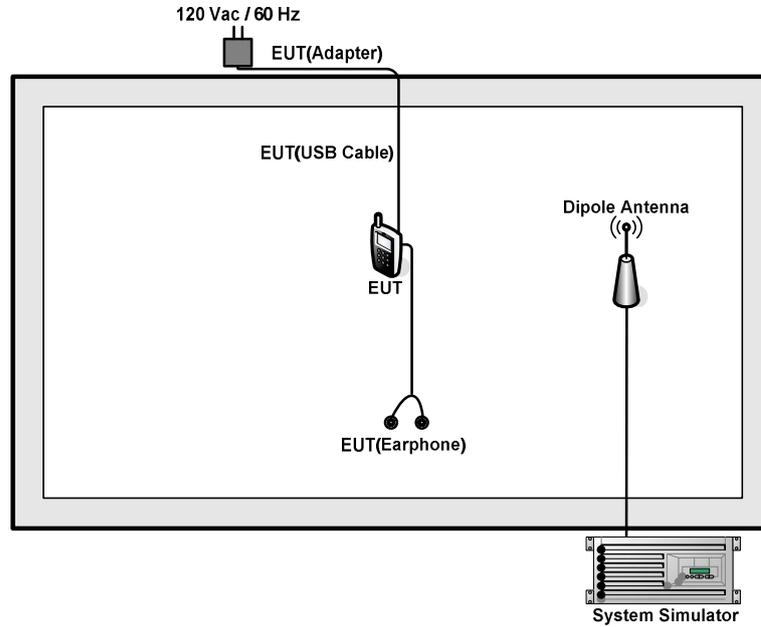

For 27L

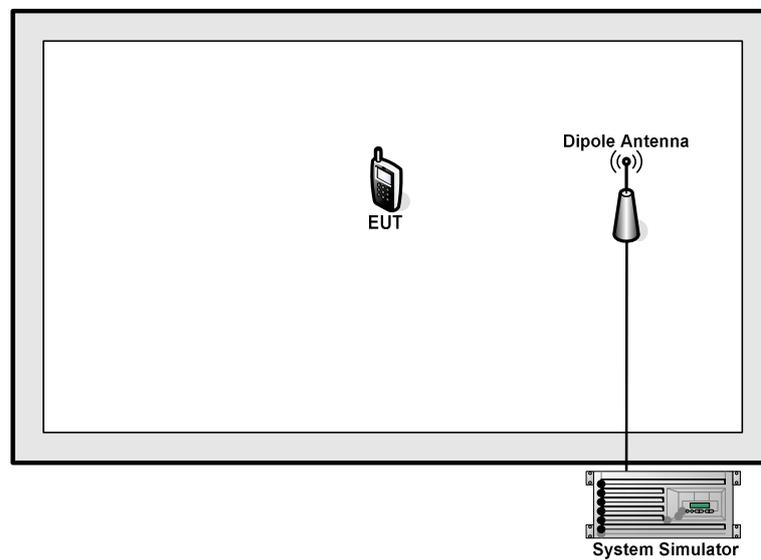



2.3 Support Unit used in test configuration

Item	Equipment	Trade Name	Model No.	FCC ID	Data Cable	Power Cord
1.	System Simulator	R&S	CMU 200	N/A	N/A	Unshielded, 1.8 m
2.	DC Power Supply	GW INSTEK	GPS-3030D	N/A	N/A	Unshielded, 1.8 m

2.4 Measurement Results Explanation Example

For all conducted test items:

The offset level is set in the spectrum analyzer to compensate the RF cable loss and attenuator factor between RF conducted output port and spectrum analyzer. With the offset compensation, the spectrum analyzer reading level will be exactly the RF output level.

The spectrum analyzer offset is derived from RF cable loss and attenuator factor.

$$\text{Offset} = \text{RF cable loss} + \text{attenuator factor}.$$

The following shows an offset computation example with RF cable loss 5.1 dB and a 10dB attenuator.

Example :

$$\begin{aligned} \text{Offset(dB)} &= \text{RF cable loss(dB)} + \text{attenuator factor(dB)}. \\ &= 5.1 + 10 = 15.1 \text{ (dB)} \end{aligned}$$

3 Conducted Test Result

3.1 Measuring Instruments

See list of measuring instruments of this test report.

3.2 Test Setup

3.2.1 Conducted Output Power



3.2.2 Peak-to-Average Ratio, Occupied Bandwidth, Conducted Band-Edge and Conducted Spurious Emission

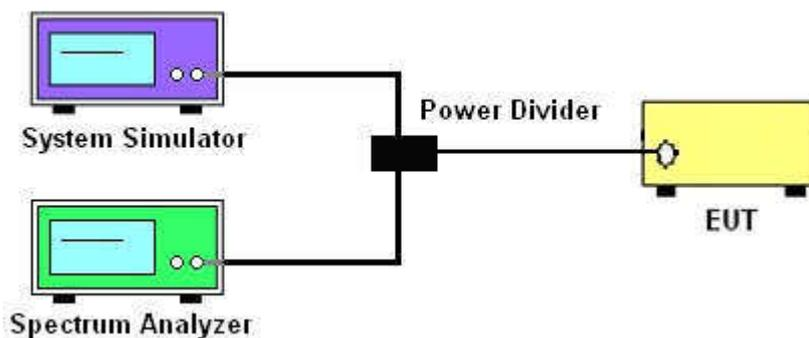

3.2.3 Frequency Stability

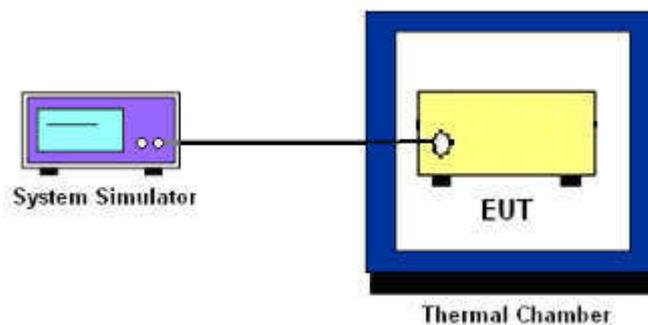

3.3 Test Result of Conducted Test

Please refer to Appendix A.



3.4 Conducted Output Power and ERP/EIRP

3.4.1 Description of the Conducted Output Power and ERP/EIRP

A system simulator was used to establish communication with the EUT. Its parameters were set to enforce EUT transmitting at the maximum power. The measured power in the radio frequency on the transmitter output terminals shall be reported.

The ERP of mobile transmitters must not exceed 7 Watts for GSM850 and WCDMA Band V.

The EIRP of mobile transmitters must not exceed 2 Watts for GSM1900 and WCDMA Band II.

The EIRP of mobile transmitters must not exceed 1 Watts for WCDMA Band IV.

According to KDB 412172 D01 Power Approach,

$EIRP = P_T + G_T - L_C$, $ERP = EIRP - 2.15$, where

P_T = transmitter output power in dBm

G_T = gain of the transmitting antenna in dBi

L_C = signal attenuation in the connecting cable between the transmitter and antenna in dB

3.4.2 Test Procedures

1. The transmitter output port was connected to the system simulator.
2. Set EUT at maximum power through system simulator.
3. Select lowest, middle, and highest channels for each band and different modulation.
4. Measure the maximum burst average power for GSM and maximum average power for other modulation signal.



3.5 Peak-to-Average Ratio

3.5.1 Description of the PAR Measurement

The peak-to-average ratio (PAR) of the transmission may not exceed 13 dB.

3.5.2 Test Procedures

1. The testing follows FCC KDB 971168 D01 v03 Section 5.7.1.
2. The EUT was connected to spectrum analyzer and system simulator via a power divider.
3. Set EUT to transmit at maximum output power.
4. When the duty cycle is less than 98%, then signal gating will be implemented on the spectrum analyzer by triggering from the system simulator.
5. Set the CCDF (Complementary Cumulative Distribution Function) option of the spectrum analyzer. Record the maximum PAPR level associated with a probability of 0.1%.



3.6 99% Occupied Bandwidth and 26dB Bandwidth Measurement

3.6.1 Description of 99% Occupied Bandwidth and 26dB Bandwidth Measurement

The occupied bandwidth is the width of a frequency band such that, below the lower and above the upper frequency limits, the mean powers emitted are each equal to a specified percentage 0.5% of the total mean transmitted power.

The 26 dB emission bandwidth is defined as the frequency range between two points, one above and one below the carrier frequency, at which the spectral density of the emission is attenuated 26 dB below the maximum in-band spectral density of the modulated signal. Spectral density (power per unit bandwidth) is to be measured with a detector of resolution bandwidth equal to approximately 1.0% of the emission bandwidth.

3.6.2 Test Procedures

1. The testing follows FCC KDB 971168 v03 Section 4.2.
2. The EUT was connected to spectrum analyzer and system simulator via a power divider.
3. The spectrum analyzer center frequency is set to the nominal EUT channel center frequency. The span range for the spectrum analyzer shall be between two and five times the anticipated OBW.
4. The nominal resolution bandwidth (RBW) shall be in the range of 1 to 5 % of the anticipated OBW, and the VBW shall be at least 3 times the RBW.
5. Set the detection mode to peak, and the trace mode to max hold.
6. Determine the reference value: Set the EUT to transmit a modulated signal. Allow the trace to stabilize. Set the spectrum analyzer marker to the highest level of the displayed trace.
(this is the reference value)
7. Determine the “-26 dB down amplitude” as equal to (Reference Value – X).
8. Place two markers, one at the lowest and the other at the highest frequency of the envelope of the spectral display such that each marker is at or slightly below the “-X dB down amplitude” determined in step 6. If a marker is below this “-X dB down amplitude” value it shall be placed as close as possible to this value. The OBW is the positive frequency difference between the two markers.
9. Use the 99 % power bandwidth function of the spectrum analyzer and report the measured bandwidth.



3.7 Conducted Band Edge

3.7.1 Description of Conducted Band Edge Measurement

The power of any emission outside of the authorized operating frequency ranges must be lower than the transmitter power (P) by a factor of at least $43 + 10 \log (P)$ dB.

3.7.2 Test Procedures

1. The testing follows FCC KDB 971168 D01 v03 Section 6.0.
2. The EUT was connected to the spectrum analyzer and system simulator via a power divider.
3. The RF output of EUT was connected to the spectrum analyzer by an RF cable and attenuator. The path loss was compensated to the results for each measurement.
4. The band edges of low and high channels for the highest RF powers were measured.
5. The RF fundamental frequency should be excluded against the limit line in the operating frequency band.
6. The limit line is derived from $43 + 10\log(P)$ dB below the transmitter power P(Watts)
= $P(W) - [43 + 10\log(P)]$ (dB)
= $[30 + 10\log(P)]$ (dBm) - $[43 + 10\log(P)]$ (dB)
= -13dBm.



3.8 Conducted Spurious Emission

3.8.1 Description of Conducted Spurious Emission Measurement

The power of any emission outside of the authorized operating frequency ranges must be lower than the transmitter power (P) by a factor of at least $43 + 10 \log (P)$ dB.

It is measured by means of a calibrated spectrum analyzer and scanned from 30 MHz up to a frequency including its 10th harmonic.

3.8.2 Test Procedures

1. The testing follows FCC KDB 971168 D01 v03 Section 6.0.
2. The EUT was connected to the spectrum analyzer and system simulator via a power divider.
3. The RF output of EUT was connected to the spectrum analyzer by an RF cable and attenuator. The path loss was compensated to the results for each measurement.
4. The middle channel for the highest RF power within the transmitting frequency was measured.
5. The conducted spurious emission for the whole frequency range was taken.
6. The RF fundamental frequency should be excluded against the limit line in the operating frequency band.
7. The limit line is derived from $43 + 10\log(P)$ dB below the transmitter power P(Watts)
= $P(W) - [43 + 10\log(P)]$ (dB)
= $[30 + 10\log(P)]$ (dBm) - $[43 + 10\log(P)]$ (dB)
= -13dBm.



3.9 Frequency Stability

3.9.1 Description of Frequency Stability Measurement

The frequency stability shall be measured by variation of ambient temperature and variation of primary supply voltage to ensure that the fundamental emission stays within the authorized frequency block. The frequency stability of the transmitter shall be maintained within $\pm 0.00025\%$ ($\pm 2.5\text{ppm}$) of the center frequency.

3.9.2 Test Procedures for Temperature Variation

1. The testing follows FCC KDB 971168 D01 v03 Section 9.0.
2. The EUT was set up in the thermal chamber and connected with the system simulator.
3. With power OFF, the temperature was decreased to -30°C and the EUT was stabilized before testing. Power was applied and the maximum change in frequency was recorded within one minute.
4. With power OFF, the temperature was raised in 10°C steps up to 50°C . The EUT was stabilized at each step for at least half an hour. Power was applied and the maximum frequency change was recorded within one minute.

3.9.3 Test Procedures for Voltage Variation

1. The testing follows FCC KDB 971168 D01 v03 Section 9.0.
2. The EUT was placed in a temperature chamber at $20\pm 5^{\circ}\text{C}$ and connected with the system simulator.
3. The power supply voltage to the EUT was varied from 85% to 115% of the nominal value measured at the input to the EUT.
4. The variation in frequency was measured for the worst case.

4 Radiated Test Items

4.1 Measuring Instruments

See list of measuring instruments of this test report.

4.2 Test Setup

4.2.1 For radiated test from 30MHz to 1GHz

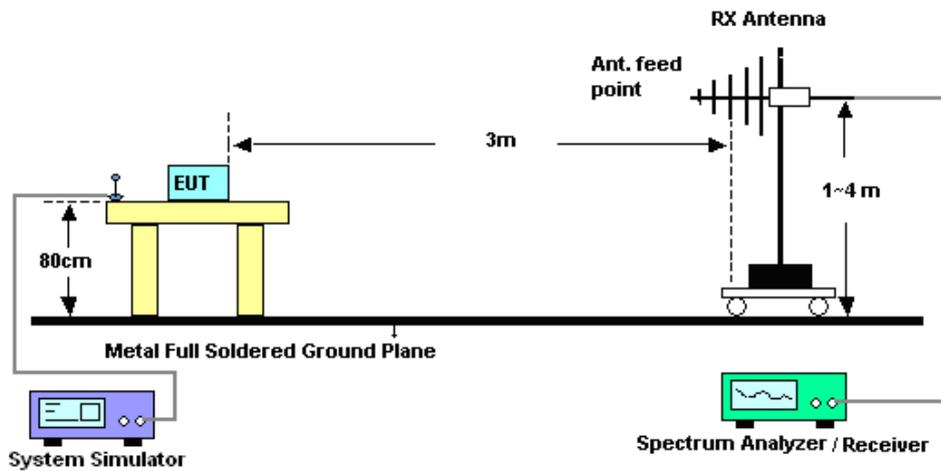

4.2.2 For radiated test above 1GHz

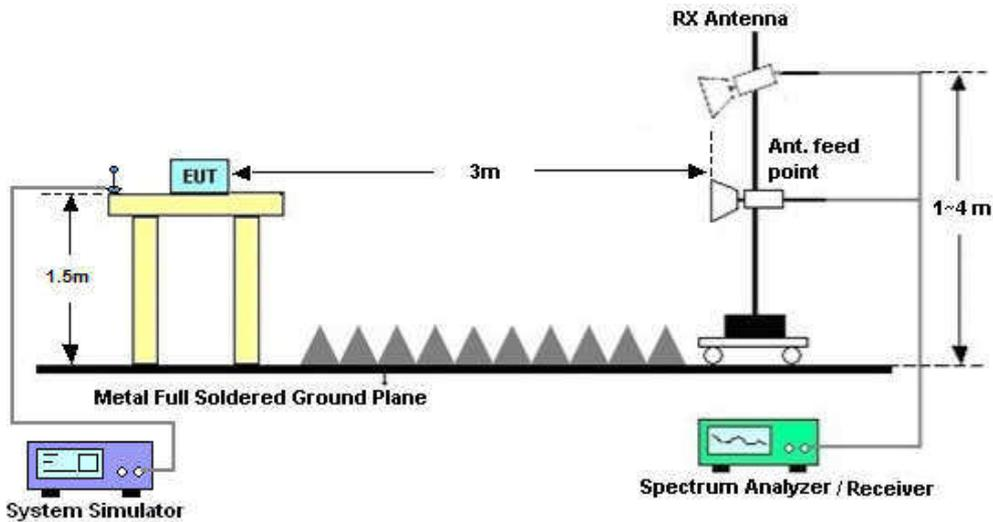

4.3 Test Result of Radiated Test

Please refer to Appendix B.



4.4 Field Strength of Spurious Radiation Measurement

4.4.1 Description of Field Strength of Spurious Radiated Measurement

The power of any emission outside of the authorized operating frequency ranges must be attenuated below the transmitter power (P) by a factor of at least $43 + 10 \log (P)$ dB. The spectrum is scanned from 30 MHz up to a frequency including its 10th harmonic.

4.4.2 Test Procedures

1. The testing follows FCC KDB 971168 D01 v03 Section 5.8 and ANSI/TIA-603-E Section 2.2.12.
2. The EUT was placed on a rotatable wooden table 0.8 meters for frequency below 1GHz and 1.5 meter for frequency above 1GHz above the ground.
3. The EUT was set 3 meters from the receiving antenna, which was mounted on the antenna tower.
4. The table was rotated 360 degrees to determine the position of the highest spurious emission.
5. The height of the receiving antenna is varied between one meter and four meters to search for the maximum spurious emission for both horizontal and vertical polarizations.
6. Make the measurement with the spectrum analyzer's RBW = 1MHz, VBW = 3MHz, taking record of maximum spurious emission.
7. A horn antenna was substituted in place of the EUT and was driven by a signal generator.
8. Tune the output power of signal generator to the same emission level with EUT maximum spurious emission.
9. Taking the record of output power at antenna port.
10. Repeat step 7 to step 8 for another polarization.
11. $EIRP \text{ (dBm)} = S.G. \text{ Power} - Tx \text{ Cable Loss} + Tx \text{ Antenna Gain}$
12. $ERP \text{ (dBm)} = EIRP - 2.15$
13. The RF fundamental frequency should be excluded against the limit line in the operating frequency band.
14. The limit line is derived from $43 + 10\log(P)$ dB below the transmitter power P(Watts)
 $= P(W) - [43 + 10\log(P)] \text{ (dB)}$
 $= [30 + 10\log(P)] \text{ (dBm)} - [43 + 10\log(P)] \text{ (dB)}$
 $= -13\text{dBm}.$



5 List of Measuring Equipment

Instrument	Manufacturer	Model No.	Serial No.	Characteristics	Calibration Date	Test Date	Due Date	Remark
Spectrum Analyzer	R&S	FSV40	101040	10Hz~40GHz	Aug. 08, 2017	Dec. 06, 2017	Aug. 07, 2018	Conducted (TH01-KS)
Radio communication analyzer	Anritsu	MT8820C	6201300652	2G/3G/LTE_ full band	Aug. 08, 2017	Dec. 06, 2017	Aug. 07, 2018	Conducted (TH01-KS)
Thermal Chamber	Ten Billion	TTC-B3S	TBN-960502	-40~+150°C	Oct. 12, 2017	Dec. 06, 2017	Oct. 11, 2018	Conducted (TH01-KS)
EXA Spectrum Analyzer	Keysight	N9010A	MY55150244	10Hz~44GHz	Apr. 18, 2017	Dec. 09, 2017	Apr. 17, 2018	Radiation (03CH03-KS)
Bilog Antenna	TeseQ	CBL6112D	35406	25MHz~2GHz	Apr. 22, 2017	Dec. 09, 2017	Apr. 21, 2018	Radiation (03CH03-KS)
Horn Antenna	Schwarzbeck	BBHA9120 D	9120D-1356	1GHz~18GHz	Apr. 22, 2017	Dec. 09, 2017	Apr. 21, 2018	Radiation (03CH03-KS)
SHF-EHF Horn	Schwarzbeck	BBHA 9170	BBHA170249	15GHz~40GHz	Feb. 15, 2017	Dec. 09, 2017	Feb. 14, 2018	Radiation (03CH03-KS)
Amplifier	com-power	PA-103A	161069	1MHz~1000MHz / 32 dB	Apr. 18, 2017	Dec. 09, 2017	Apr. 17, 2018	Radiation (03CH03-KS)
high gain Amplifier	MITEQ	AMF-7D-00 101800-30- 10D	2025788	1GHz~18GHz	Apr. 18, 2017	Dec. 09, 2017	Apr. 17, 2018	Radiation (03CH03-KS)
Amplifier	Agilent	8449B	3008A02370	1GHz~26.5GHz	Oct. 12, 2017	Dec. 09, 2017	Oct. 11, 2018	Radiation (03CH03-KS)
AC Power Source	Chroma	61601	F104090004	N/A	NCR	Dec. 09, 2017	NCR	Radiation (03CH03-KS)
Turn Table	ChamPro	EM 1000-T	060762-T	0~360 degree	NCR	Dec. 09, 2017	NCR	Radiation (03CH03-KS)
Antenna Mast	ChamPro	EM 1000-A	060762-A	1 m~4 m	NCR	Dec. 09, 2017	NCR	Radiation (03CH03-KS)

NCR: No Calibration Required



6 Uncertainty of Evaluation

Uncertainty of Radiated Emission Measurement (30 MHz ~ 1000 MHz)

Measuring Uncertainty for a Level of Confidence of 95% ($U = 2Uc(y)$)	2.8dB
---	-------

Uncertainty of Radiated Emission Measurement (1 GHz ~ 40 GHz)

Measuring Uncertainty for a Level of Confidence of 95% ($U = 2Uc(y)$)	3.3dB
---	-------



Appendix A. Test Results of Conducted Test

Conducted Output Power(Average power)

Conducted Power (*Unit: dBm)						
Band	GSM850			GSM1900		
Channel	128	189	251	512	661	810
Frequency	824.2	836.4	848.8	1850.2	1880.0	1909.8
GSM	32.80	32.78	32.67	29.79	29.91	30.03
GPRS class 8	32.78	32.77	32.65	29.78	29.90	30.02
GPRS class 10	29.31	29.37	29.21	27.14	27.21	27.33
GPRS class 11	27.31	27.32	27.40	25.04	25.03	25.27
GPRS class 12	25.96	25.92	25.78	23.77	23.68	23.95
EGPRS class 8	26.61	26.51	26.37	25.81	25.81	25.79
EGPRS class 10	26.47	26.37	26.26	25.68	25.75	25.74
EGPRS class 11	25.10	24.91	24.76	24.64	24.69	24.69
EGPRS class 12	23.57	23.42	23.16	23.33	23.37	23.34

Conducted Power (*Unit: dBm)									
Band	WCDMA Band V			WCDMA Band II			WCDMA Band IV		
Channel	4132	4182	4233	9262	9400	9538	1312	1413	1513
Frequency	826.4	836.4	846.6	1852.4	1880	1907.6	1712.4	1732.6	1752.6
AMR 12.2Kbps	23.10	23.20	23.02	23.04	23.14	23.18	22.97	22.98	22.93
RMC 12.2Kbps	23.11	23.22	23.04	23.06	23.15	23.20	22.98	22.99	22.95
HSDPA Subtest-1	21.71	21.76	21.62	21.71	21.83	21.92	21.75	21.76	21.71
HSDPA Subtest-2	21.81	21.91	21.73	21.73	21.90	21.92	21.81	21.79	21.77
HSDPA Subtest-3	21.29	21.40	21.23	21.23	21.40	21.43	21.31	21.23	21.27
HSDPA Subtest-4	21.28	21.40	21.12	21.23	21.40	21.43	21.31	21.21	21.27
DC-HSDPA Subtest-1	21.67	21.71	21.59	21.69	21.78	21.81	21.69	21.65	21.59
DC-HSDPA Subtest-2	21.66	21.76	21.58	21.65	21.70	21.85	21.67	21.70	21.58
DC-HSDPA Subtest-3	21.61	21.36	21.52	21.66	21.65	21.69	21.39	21.59	21.63
DC-HSDPA Subtest-4	21.29	21.35	21.59	21.64	21.59	21.84	21.64	21.64	21.64
HSUPA Subtest-1	21.78	21.40	21.50	21.33	21.29	21.50	21.27	21.36	21.64
HSUPA Subtest-2	20.33	20.76	20.28	20.82	20.68	20.80	20.80	20.79	20.60
HSUPA Subtest-3	20.54	20.87	20.48	20.83	20.38	20.63	20.46	20.44	20.39
HSUPA Subtest-4	20.62	20.74	20.47	20.81	20.98	20.93	20.80	20.79	20.61
HSUPA Subtest-5	21.70	21.80	21.60	21.70	21.90	22.00	21.70	21.80	21.80



ERP/EIRP

GSM850 (G _T - L _C = -3.05 dBi)			
Channel	128	189	251
	(Low)	(Mid)	(High)
Frequency	824.2	836.4	848.8
(MHz)			
Conducted Power (dBm)	32.80	32.78	32.67
Conducted Power (Watts)	1.9055	1.8967	1.8493
ERP(dBm)	27.60	27.58	27.47
ERP(Watts)	0.5754	0.5728	0.5585

EDGE850 (G _T - L _C =-3.05dBi)			
Channel	128	189	251
	(Low)	(Mid)	(High)
Frequency	824.2	836.4	848.8
(MHz)			
Conducted Power (dBm)	26.61	26.51	26.37
Conducted Power (Watts)	0.4581	0.4477	0.4335
ERP(dBm)	21.41	21.31	21.17
ERP(Watts)	0.1384	0.1352	0.1309



GSM1900 (G _T - L _C = 2.10dBi)			
Channel	512	661	810
	(Low)	(Mid)	(High)
Frequency	1850.2	1880	1909.8
(MHz)			
Conducted Power (dBm)	29.79	29.91	30.03
Conducted Power (Watts)	0.9528	0.9795	1.0069
EIRP(dBm)	31.89	32.01	32.13
EIRP(Watts)	1.5453	1.5885	1.6331

EDGE1900 (G _T - L _C = 2.10dBi)			
Channel	512	661	810
	(Low)	(Mid)	(High)
Frequency	1850.2	1880	1909.8
(MHz)			
Conducted Power (dBm)	25.81	25.81	25.79
Conducted Power (Watts)	0.3811	0.3811	0.3793
EIRP(dBm)	27.91	27.91	27.89
EIRP(Watts)	0.6180	0.6180	0.6152



WCDMA Band V ($G_T - L_C = -3.05\text{dBi}$)			
Channel	4132	4182	4233
	(Low)	(Mid)	(High)
Frequency	826.4	836.4	846.6
(MHz)			
Conducted Power (dBm)	23.11	23.22	23.04
Conducted Power (Watts)	0.2046	0.2099	0.2014
ERP(dBm)	17.91	18.02	17.84
ERP(Watts)	0.0618	0.0634	0.0608

WCDMA Band II ($G_T - L_C = 2.10\text{dBi}$)			
Channel	9262	9400	9538
	(Low)	(Mid)	(High)
Frequency	1852.4	1880	1907.6
(MHz)			
Conducted Power (dBm)	23.06	23.15	23.20
Conducted Power (Watts)	0.2023	0.2065	0.2089
EIRP(dBm)	25.16	25.25	25.30
EIRP(Watts)	0.3281	0.3350	0.3388

WCDMA Band IV ($G_T - L_C = 2.04\text{dBi}$)			
Channel	1312	1413	1513
	(Low)	(Mid)	(High)
Frequency	1712.4	1732.6	1752.6
(MHz)			
Conducted Power (dBm)	22.98	22.99	22.95
Conducted Power (Watts)	0.1986	0.1991	0.1972
EIRP(dBm)	25.02	25.03	24.99
EIRP(Watts)	0.3177	0.3184	0.3155

**Peak-to-Average Ratio**

Mode	GSM850		Limit: 13dB
Mod.	GPRS class 8	EDGE class 8	Result
Lowest CH	0.14	0.20	PASS
Middle CH	0.14	0.12	
Highest CH	0.12	0.14	

Mode	GSM1900		Limit: 13dB
Mod.	GPRS class 8	EDGE class 8	Result
Lowest CH	0.12	0.17	PASS
Middle CH	0.12	0.17	
Highest CH	0.12	0.20	

Mode	WCDMA Band V	WCDMA Band II	WCDMA Band IV	Limit: 13dB
Mod.	RMC 12.2Kbps	RMC 12.2Kbps	RMC 12.2Kbps	Result
Lowest CH	3.04	3.13	3.04	PASS
Middle CH	3.16	3.04	3.13	
Highest CH	3.10	2.99	3.07	

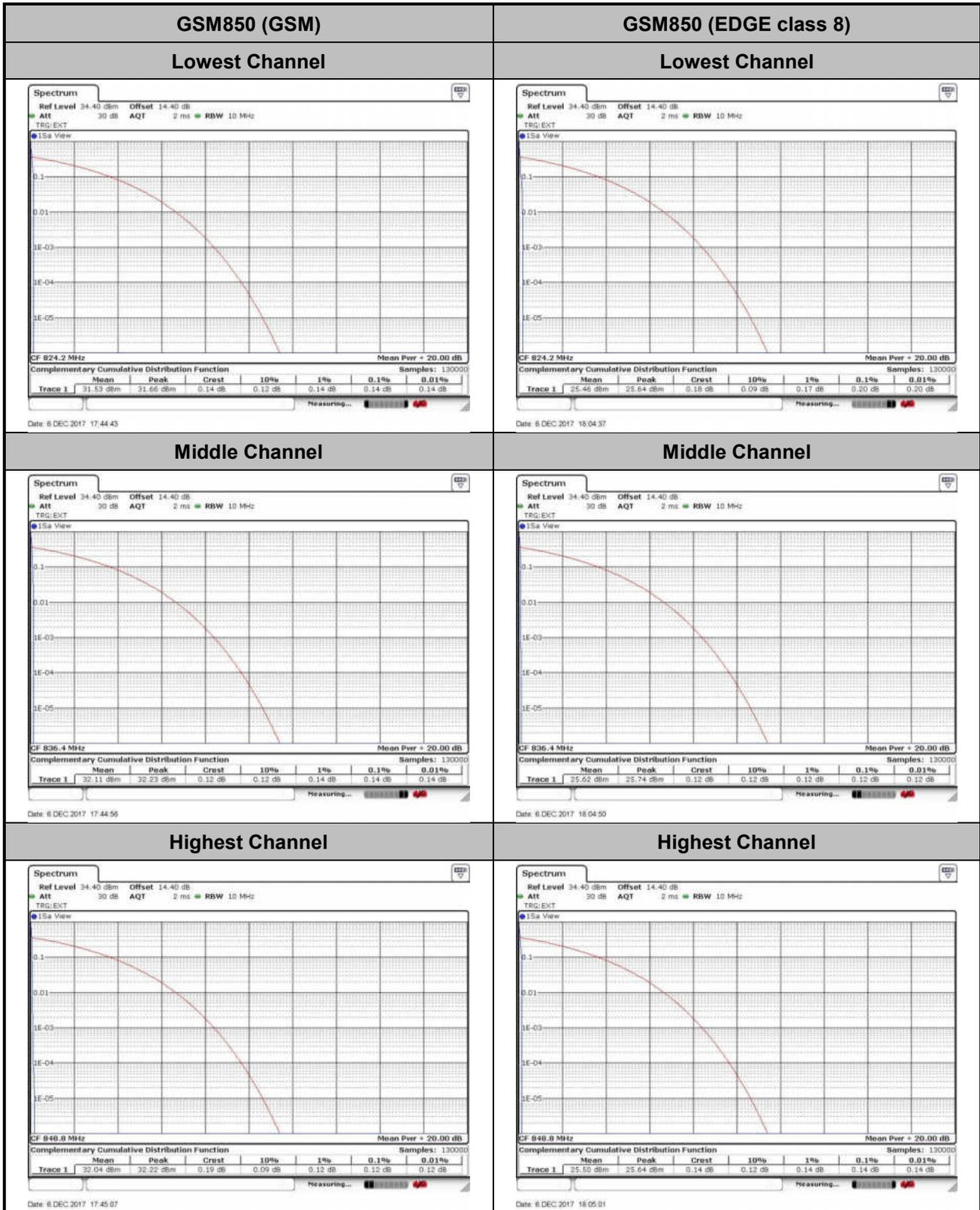

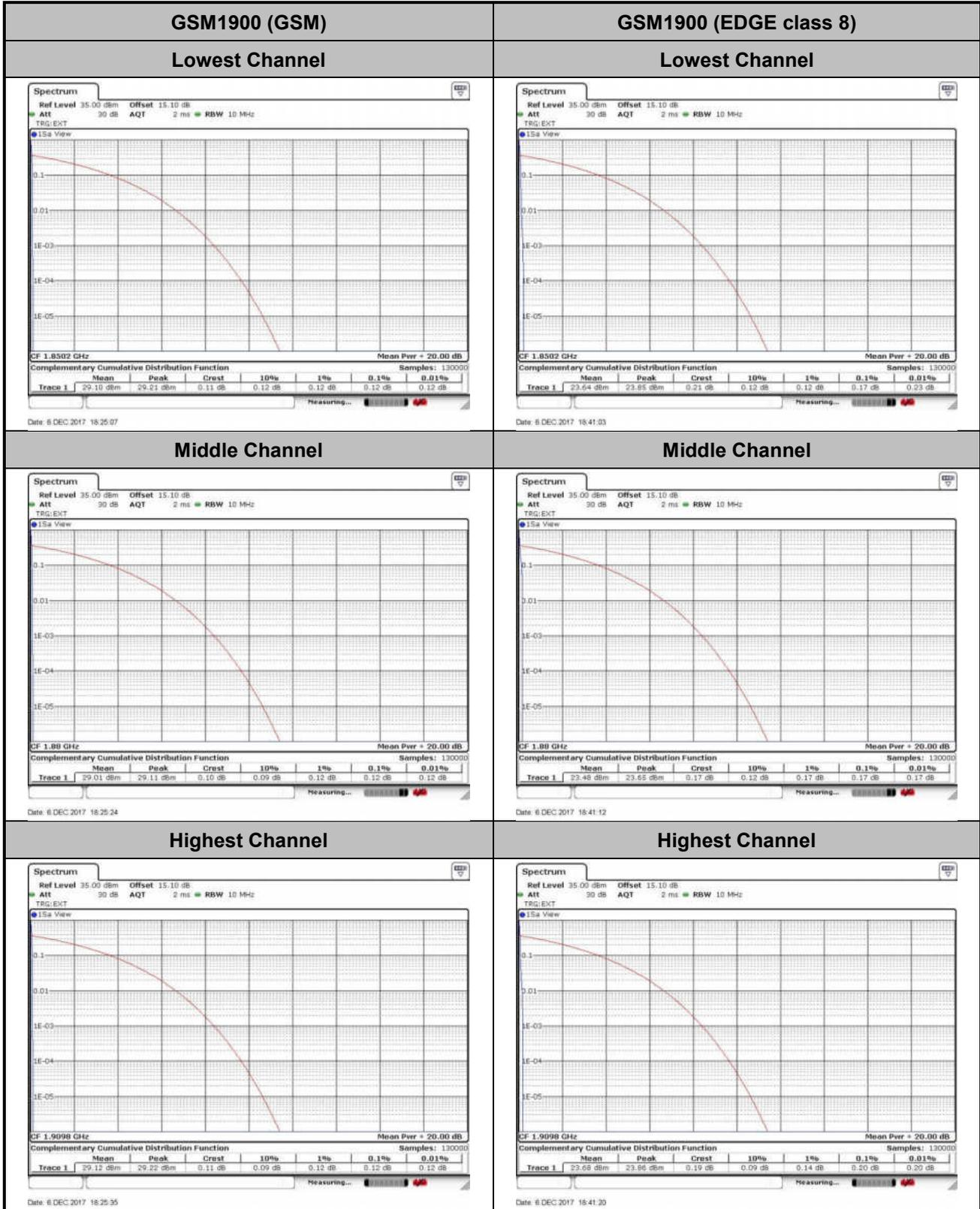

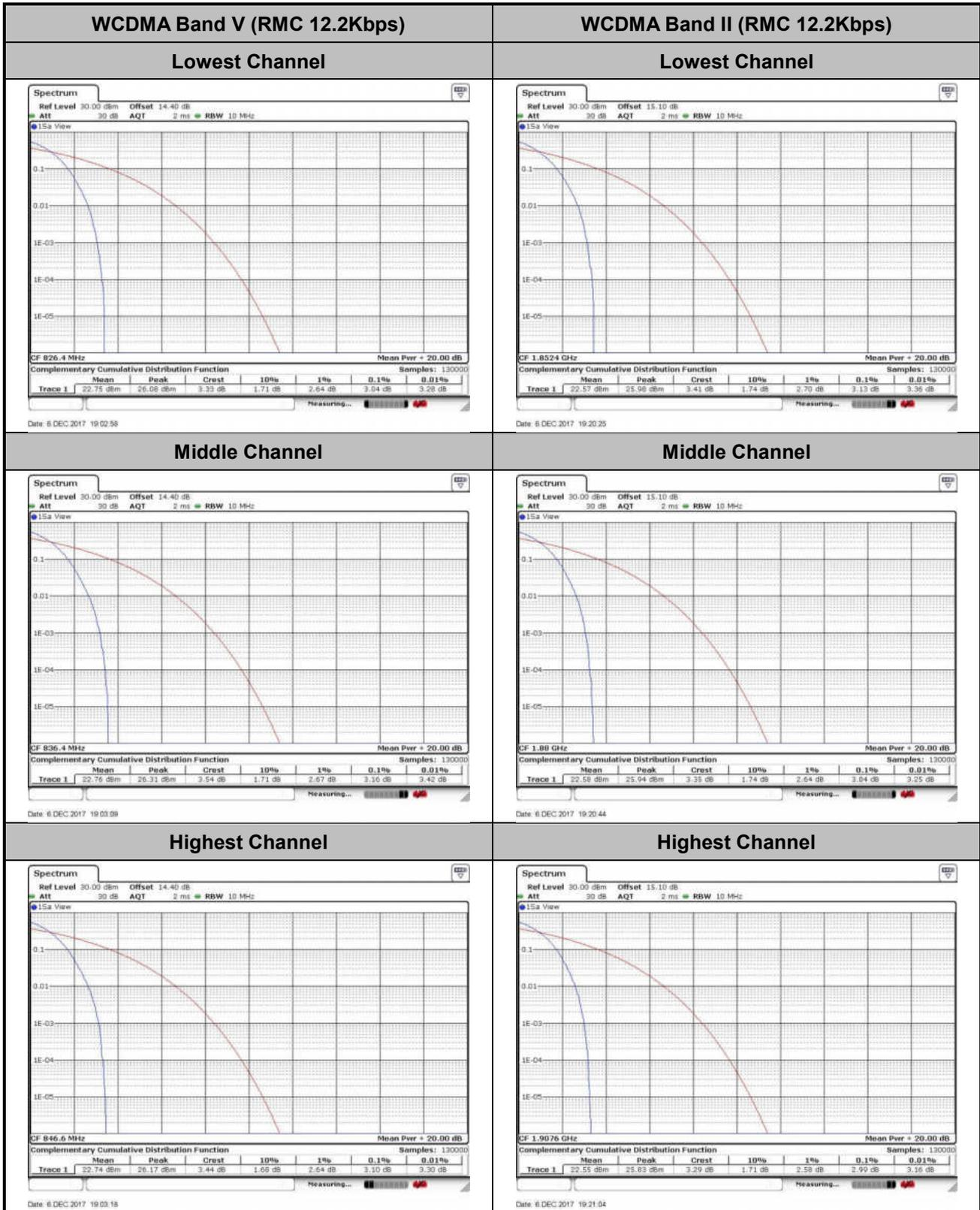



WCDMA Band IV (RMC 12.2Kbps)

Lowest Channel

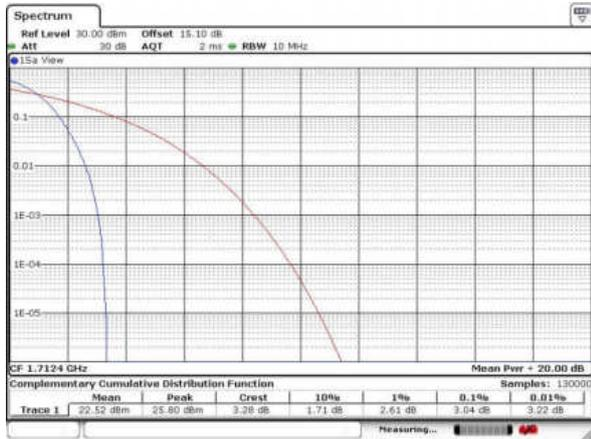

Date: 8 DEC 2017 19:38:20

Middle Channel

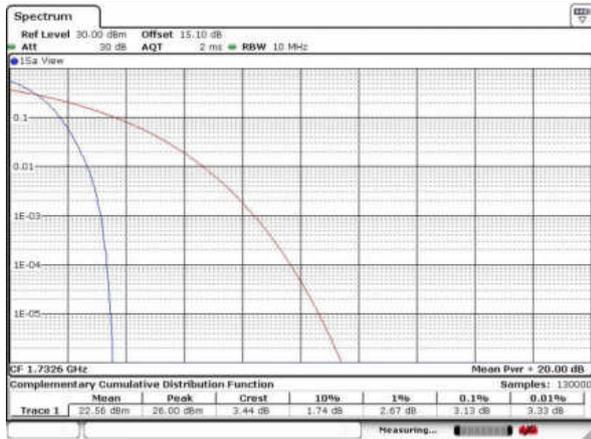

Date: 8 DEC 2017 19:38:46

Highest Channel

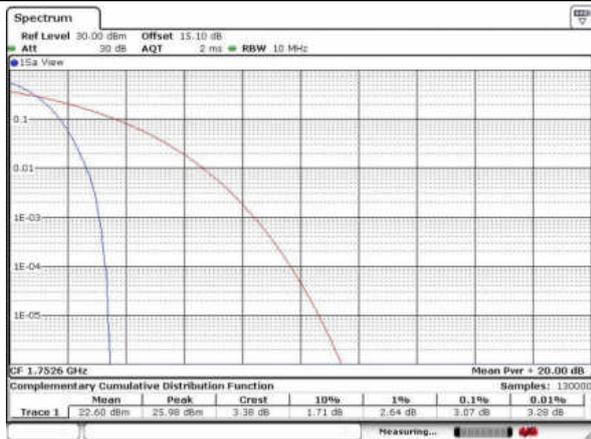

Date: 8 DEC 2017 19:40:13



26dB Bandwidth

Mode	GSM850	
Mod.	GPRS class 8	EDGE class 8
Lowest CH	0.316	0.314
Middle CH	0.311	0.313
Highest CH	0.315	0.312

Mode	GSM1900	
Mod.	GPRS class 8	EDGE class 8
Lowest CH	0.315	0.311
Middle CH	0.316	0.312
Highest CH	0.317	0.314

Mode	WCDMA Band V	WCDMA Band II	WCDMA Band IV
Mod.	RMC 12.2Kbps	RMC 12.2Kbps	RMC 12.2Kbps
Lowest CH	4.72	4.71	4.71
Middle CH	4.71	4.71	4.70
Highest CH	4.71	4.71	4.70



GSM850 (GSM)

Lowest Channel



Date: 8 DEC 2017 17:30:17

GSM850 (EDGE class 8)

Lowest Channel

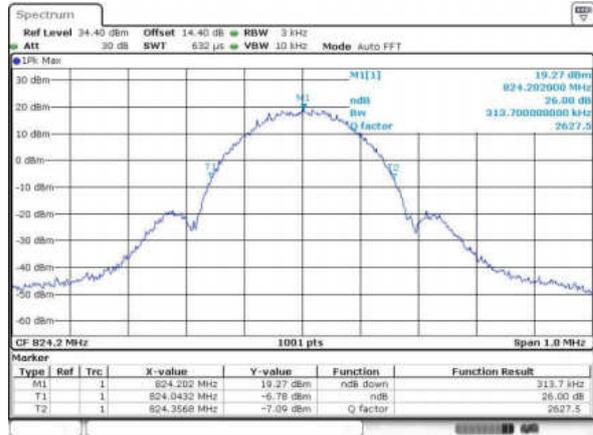

Date: 8 DEC 2017 17:48:18

Middle Channel



Date: 8 DEC 2017 17:35:49

Middle Channel

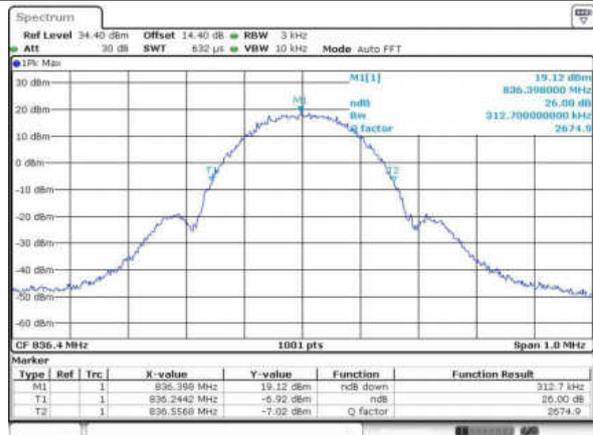

Date: 8 DEC 2017 17:48:49

Highest Channel

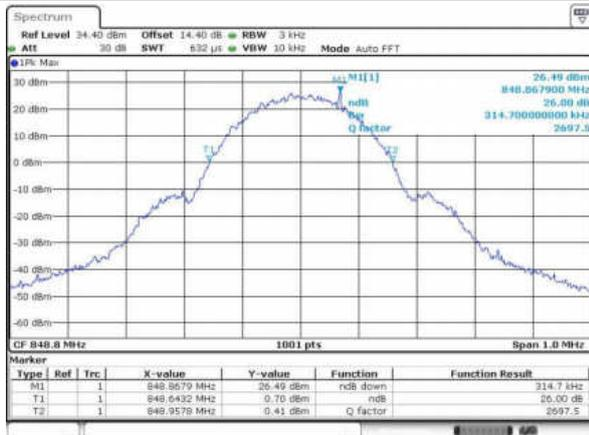

Date: 8 DEC 2017 17:31:19

Highest Channel



Date: 8 DEC 2017 17:49:21



GSM1900 (GSM)

Lowest Channel



Date: 8 DEC 2017 18:08:20

GSM1900 (EDGE class 8)

Lowest Channel

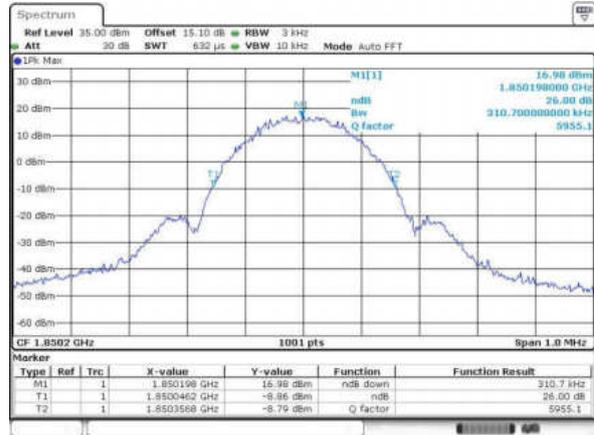

Date: 8 DEC 2017 18:27:04

Middle Channel



Date: 8 DEC 2017 18:08:11

Middle Channel

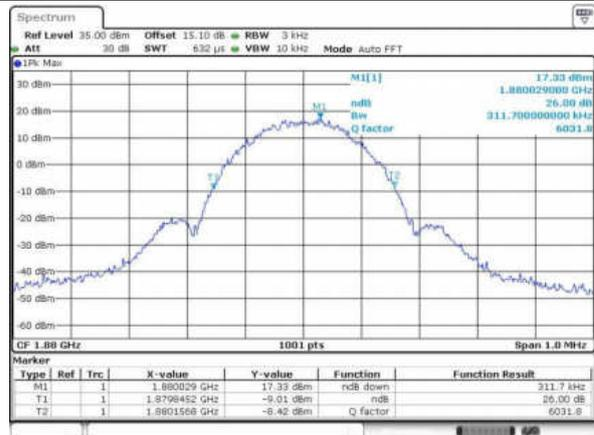

Date: 8 DEC 2017 18:27:39

Highest Channel



Date: 8 DEC 2017 18:09:49

Highest Channel

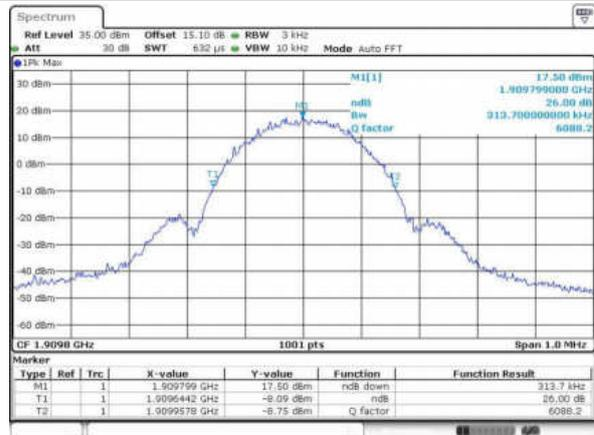

Date: 8 DEC 2017 18:28:10



WCDMA Band V (RMC 12.2Kbps)

Lowest Channel

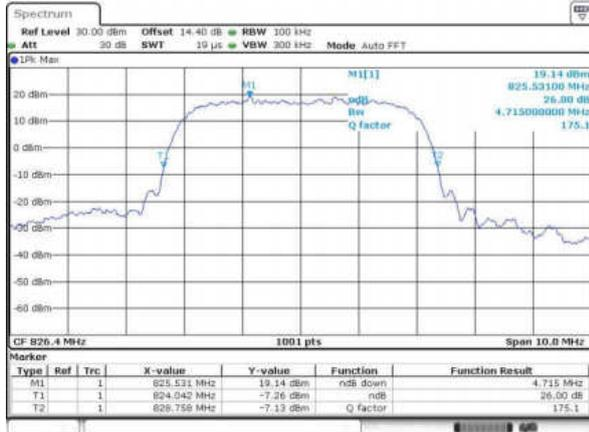

Date: 8 DEC 2017 15:46:37

WCDMA Band II (RMC 12.2Kbps)

Lowest Channel

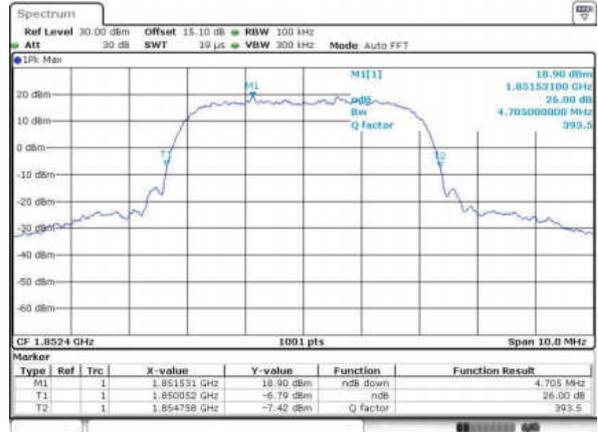

Date: 8 DEC 2017 19:04:25

Middle Channel

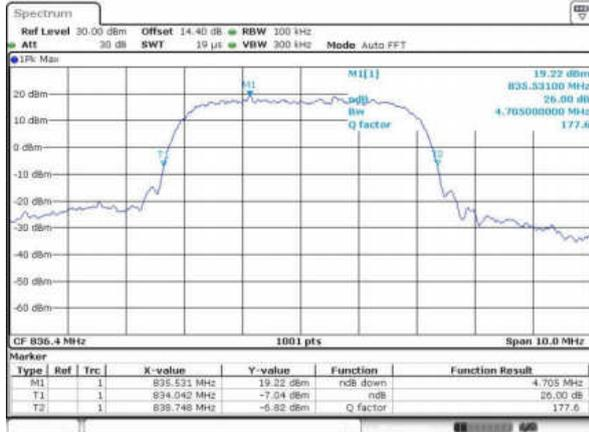

Date: 8 DEC 2017 15:47:11

Middle Channel

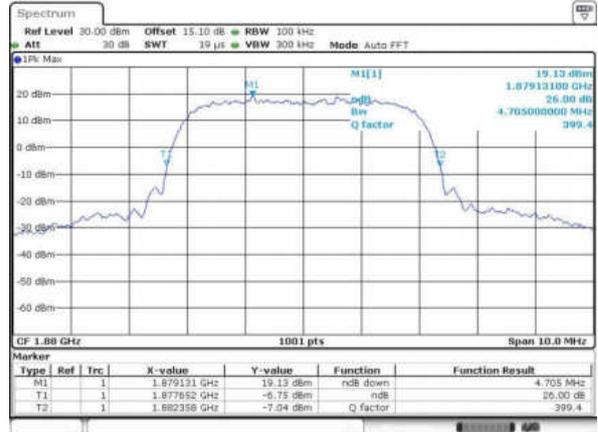

Date: 8 DEC 2017 19:05:04

Highest Channel

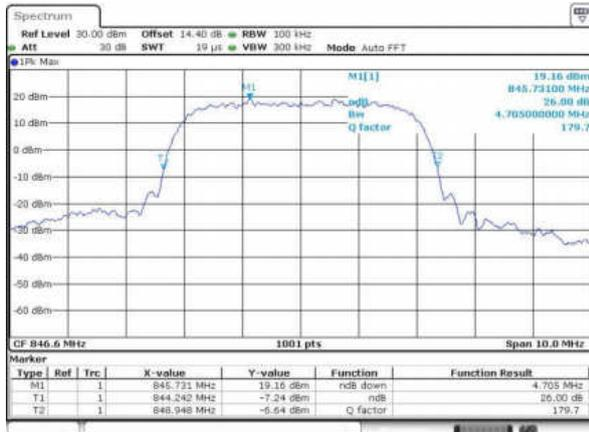

Date: 8 DEC 2017 15:47:49

Highest Channel

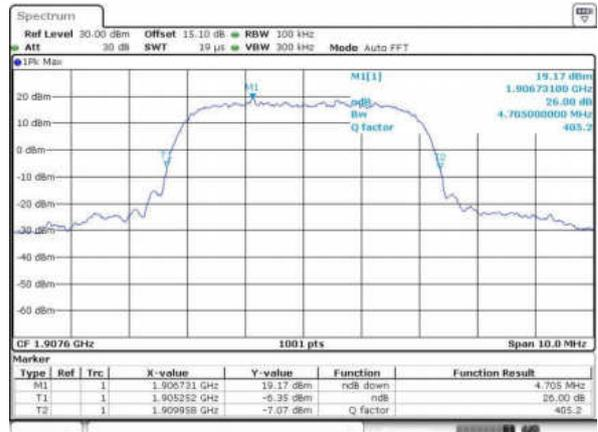

Date: 8 DEC 2017 19:05:40

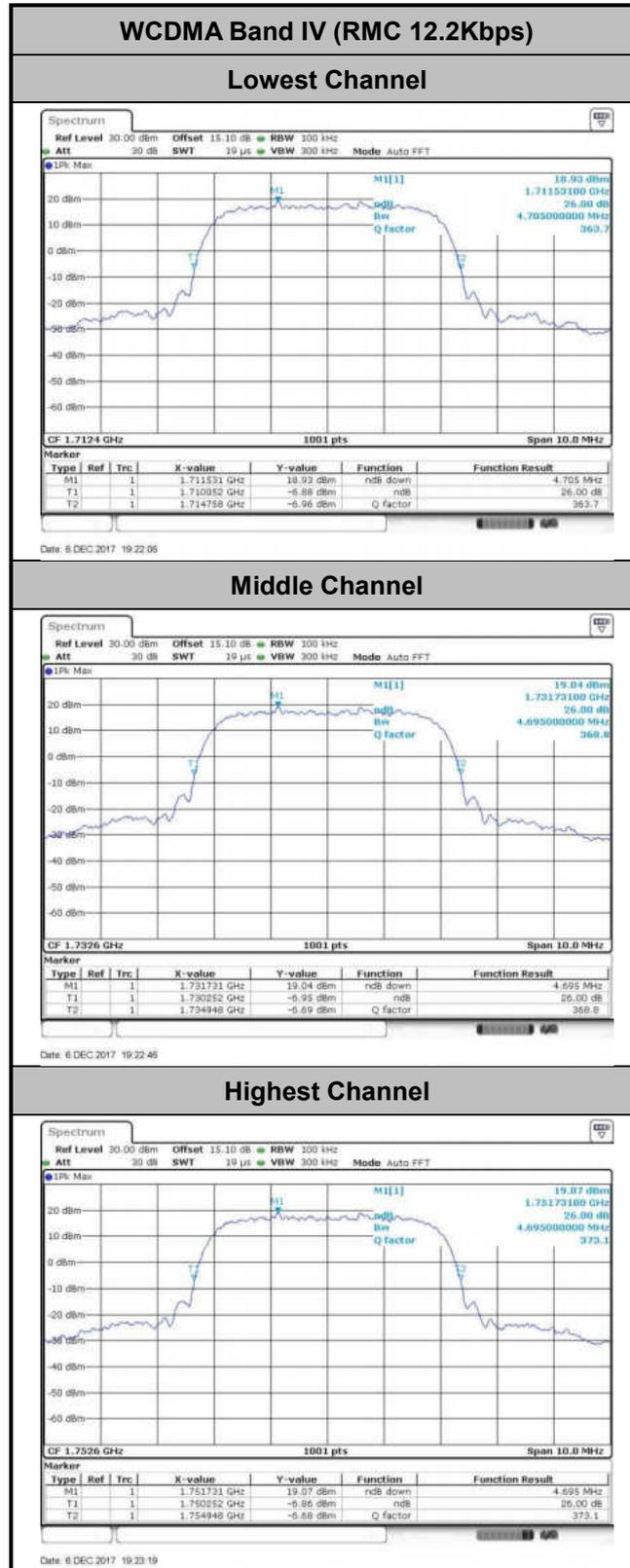



Occupied Bandwidth

Mode	GSM850	
Mod.	GPRS class 8	EDGE class 8
Lowest CH	0.241	0.243
Middle CH	0.241	0.246
Highest CH	0.242	0.244

Mode	GSM1900	
Mod.	GPRS class 8	EDGE class 8
Lowest CH	0.242	0.245
Middle CH	0.244	0.246
Highest CH	0.243	0.248

Mode	WCDMA Band V	WCDMA Band II	WCDMA Band IV
Mod.	RMC 12.2Kbps	RMC 12.2Kbps	RMC 12.2Kbps
Lowest CH	4.12	4.12	4.13
Middle CH	4.12	4.12	4.12
Highest CH	4.12	4.12	4.12



GSM850 (GSM)

Lowest Channel

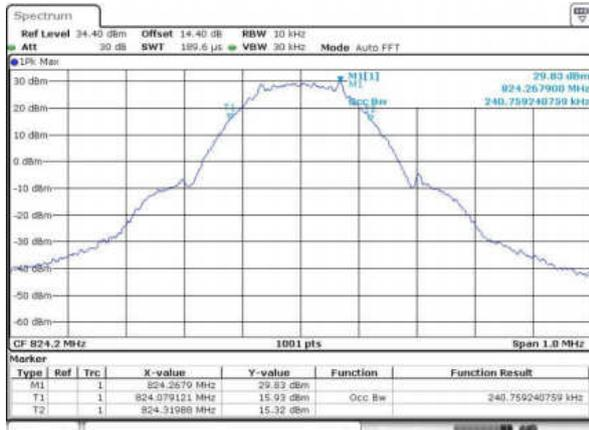

Date: 8 DEC 2017 17:31:57

GSM850 (EDGE class 8)

Lowest Channel

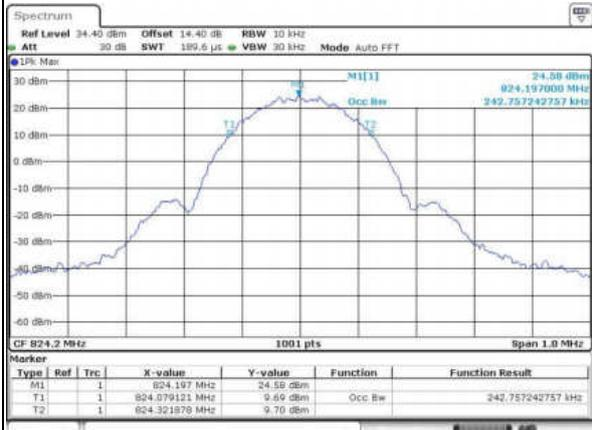

Date: 8 DEC 2017 17:52:10

Middle Channel

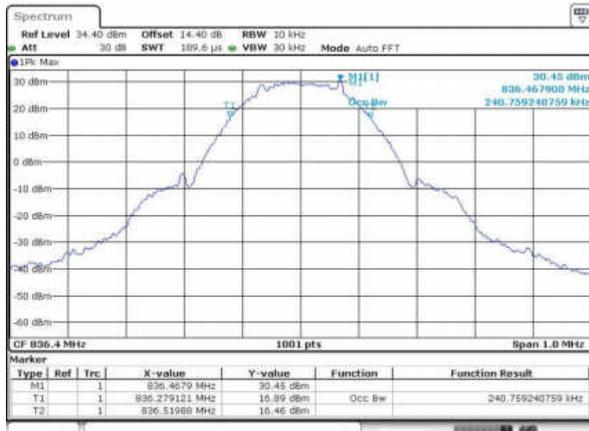

Date: 8 DEC 2017 17:32:30

Middle Channel

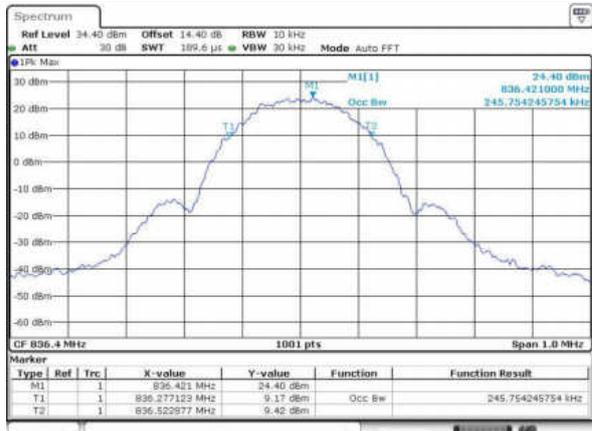

Date: 8 DEC 2017 17:52:40

Highest Channel

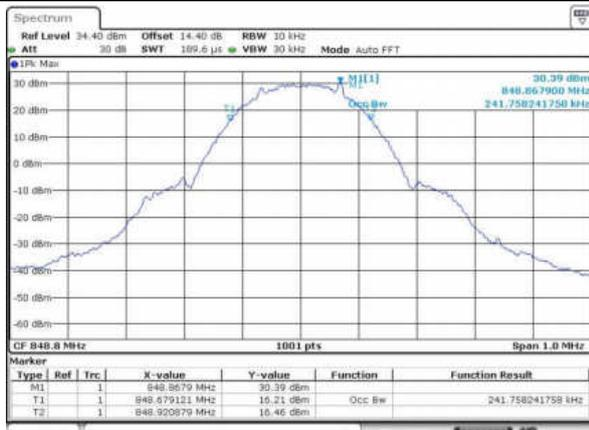

Date: 8 DEC 2017 17:33:02

Highest Channel

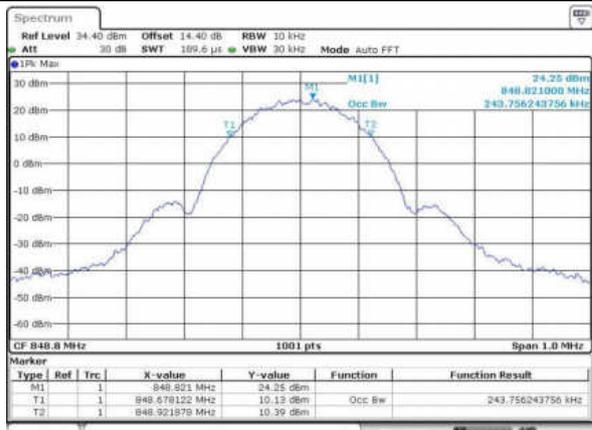

Date: 8 DEC 2017 17:53:09



GSM1900 (GSM)

Lowest Channel

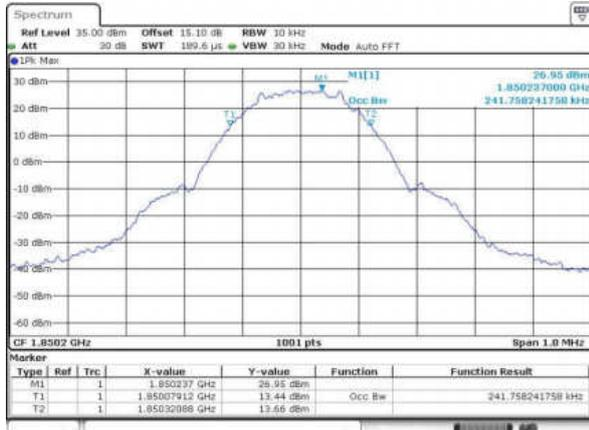

Date: 8 DEC 2017 18:12:34

GSM1900 (EDGE class 8)

Lowest Channel

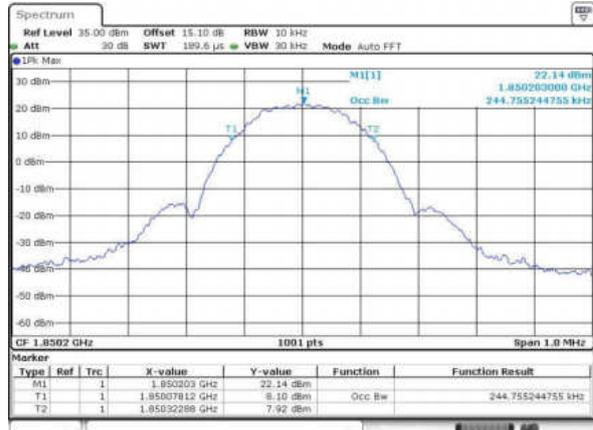

Date: 8 DEC 2017 18:30:83

Middle Channel



Date: 8 DEC 2017 18:13:11

Middle Channel



Date: 8 DEC 2017 18:31:28

Highest Channel



Date: 8 DEC 2017 18:13:44

Highest Channel

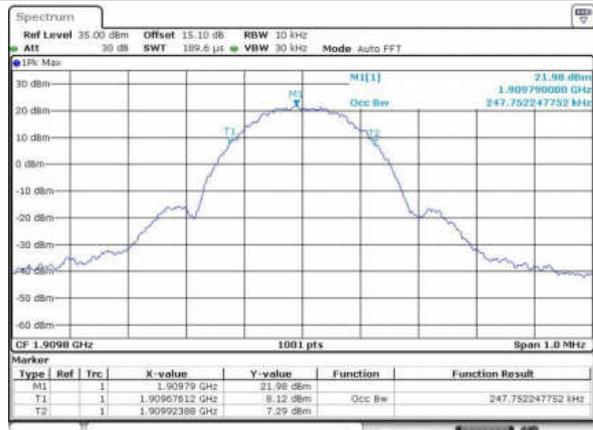

Date: 8 DEC 2017 18:30:88



WCDMA Band V (RMC 12.2Kbps)

WCDMA Band II (RMC 12.2Kbps)

Lowest Channel

Lowest Channel

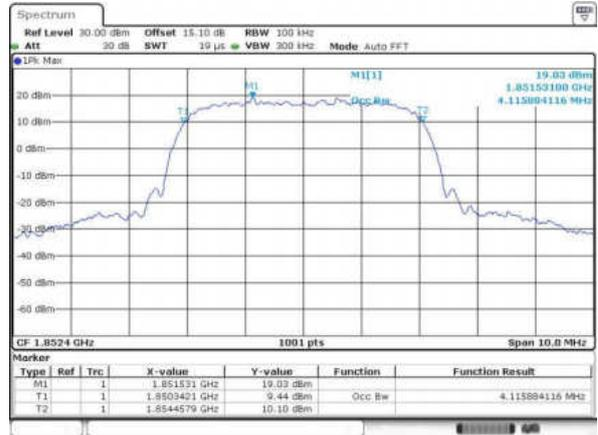
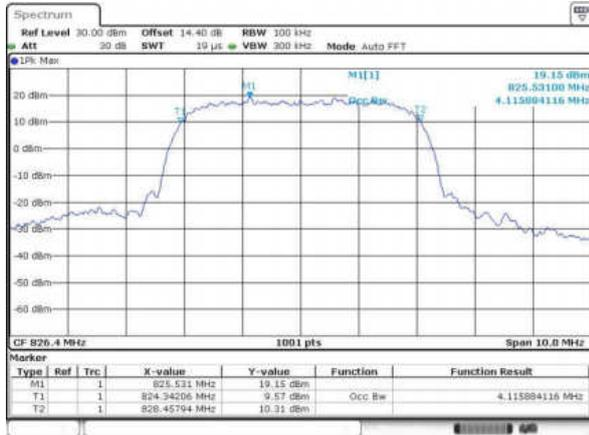

Date: 8 DEC 2017 18:50:38

Date: 8 DEC 2017 19:06:16

Middle Channel

Middle Channel

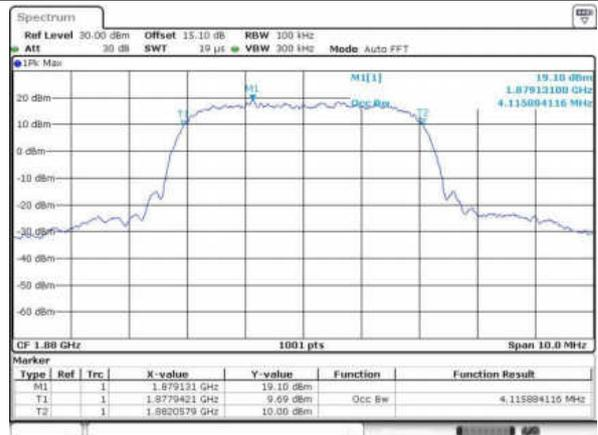
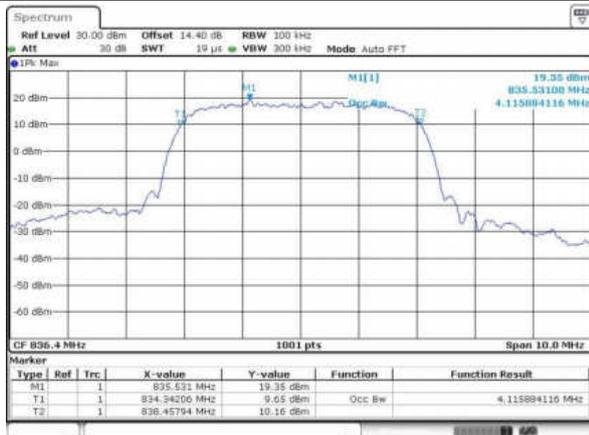

Date: 8 DEC 2017 18:51:13

Date: 8 DEC 2017 19:06:49

Highest Channel

Highest Channel

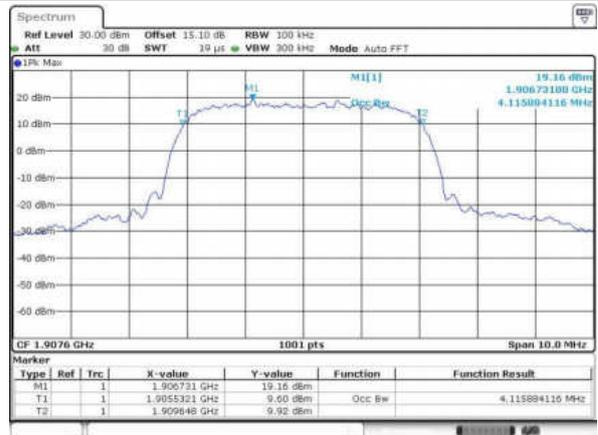
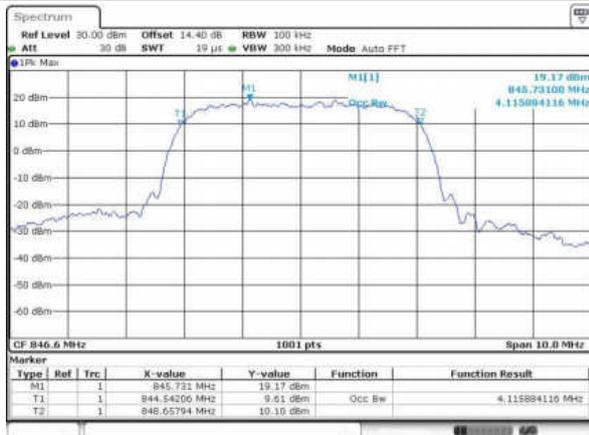

Date: 8 DEC 2017 18:52:01

Date: 8 DEC 2017 19:07:21

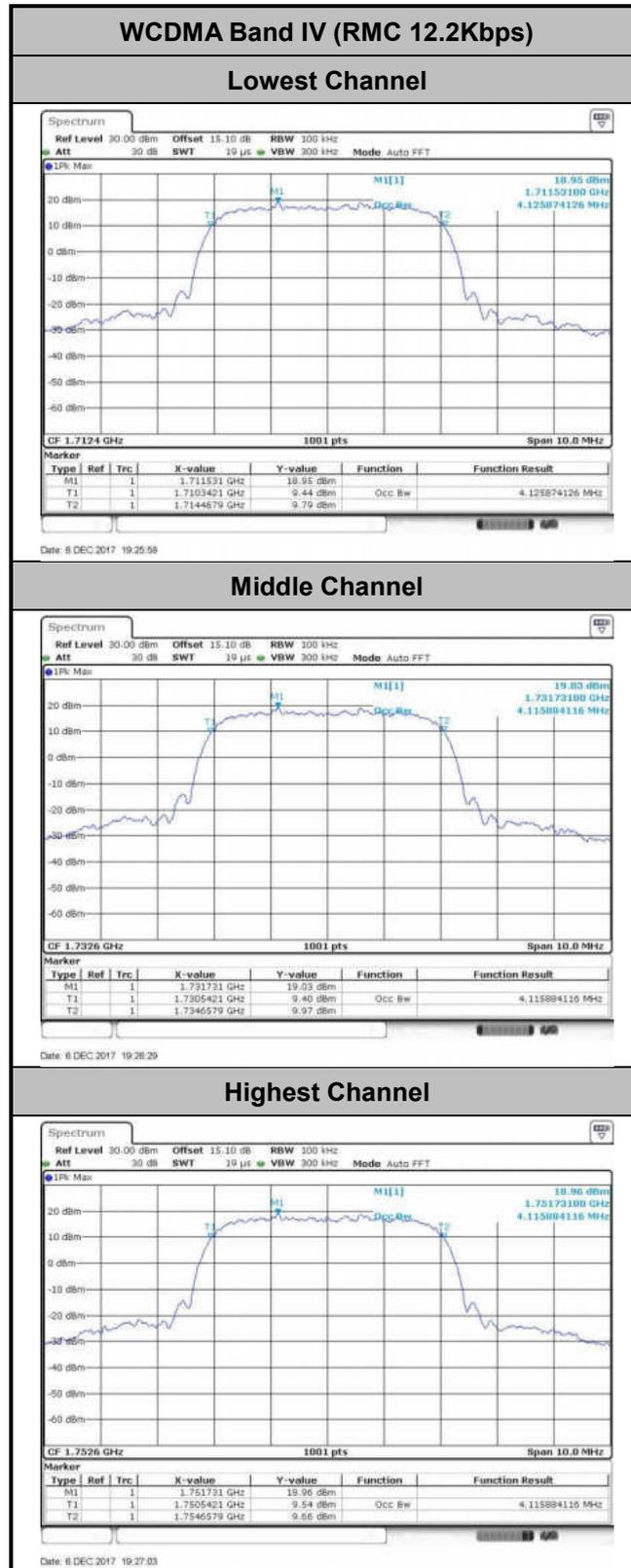



Conducted Band Edge

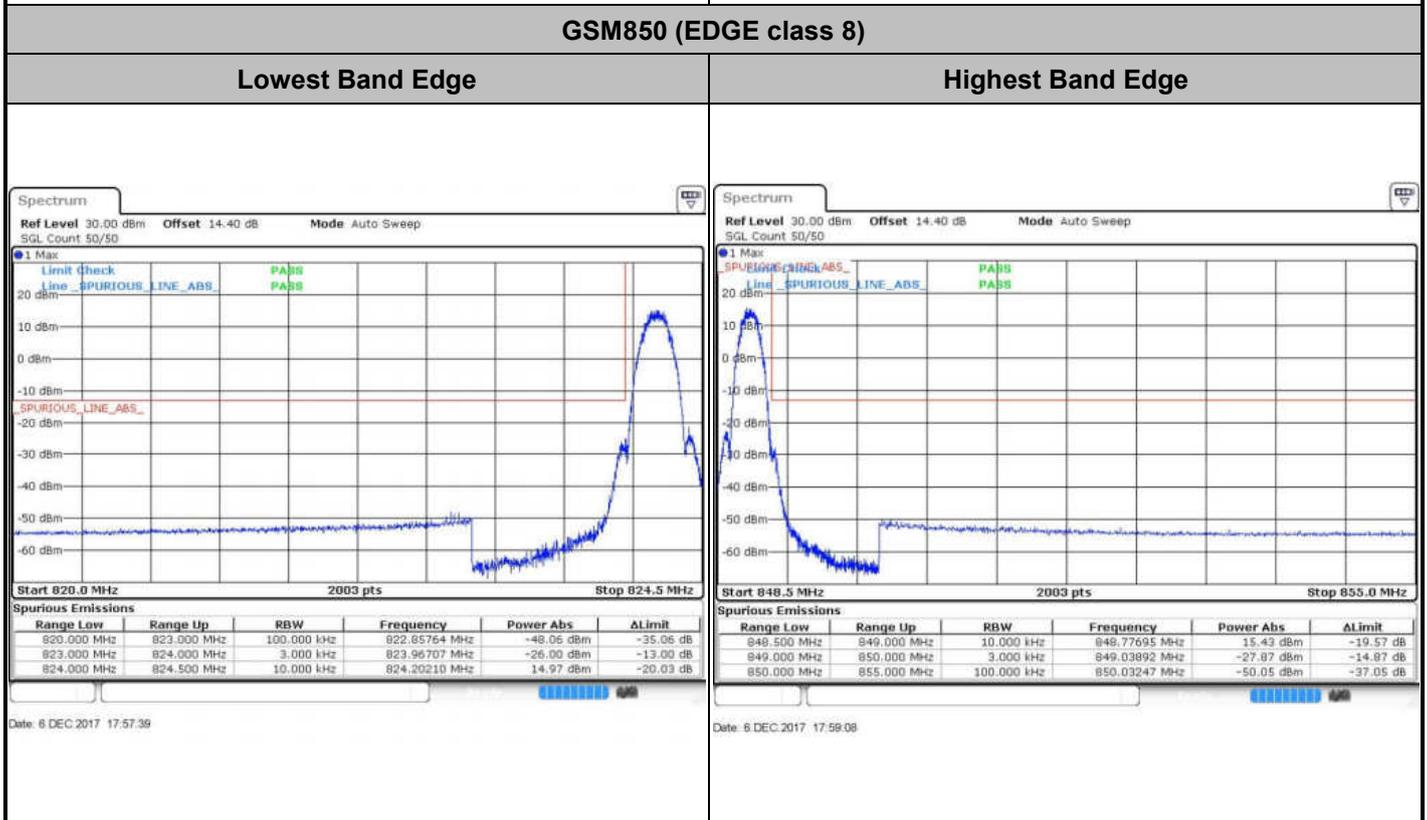
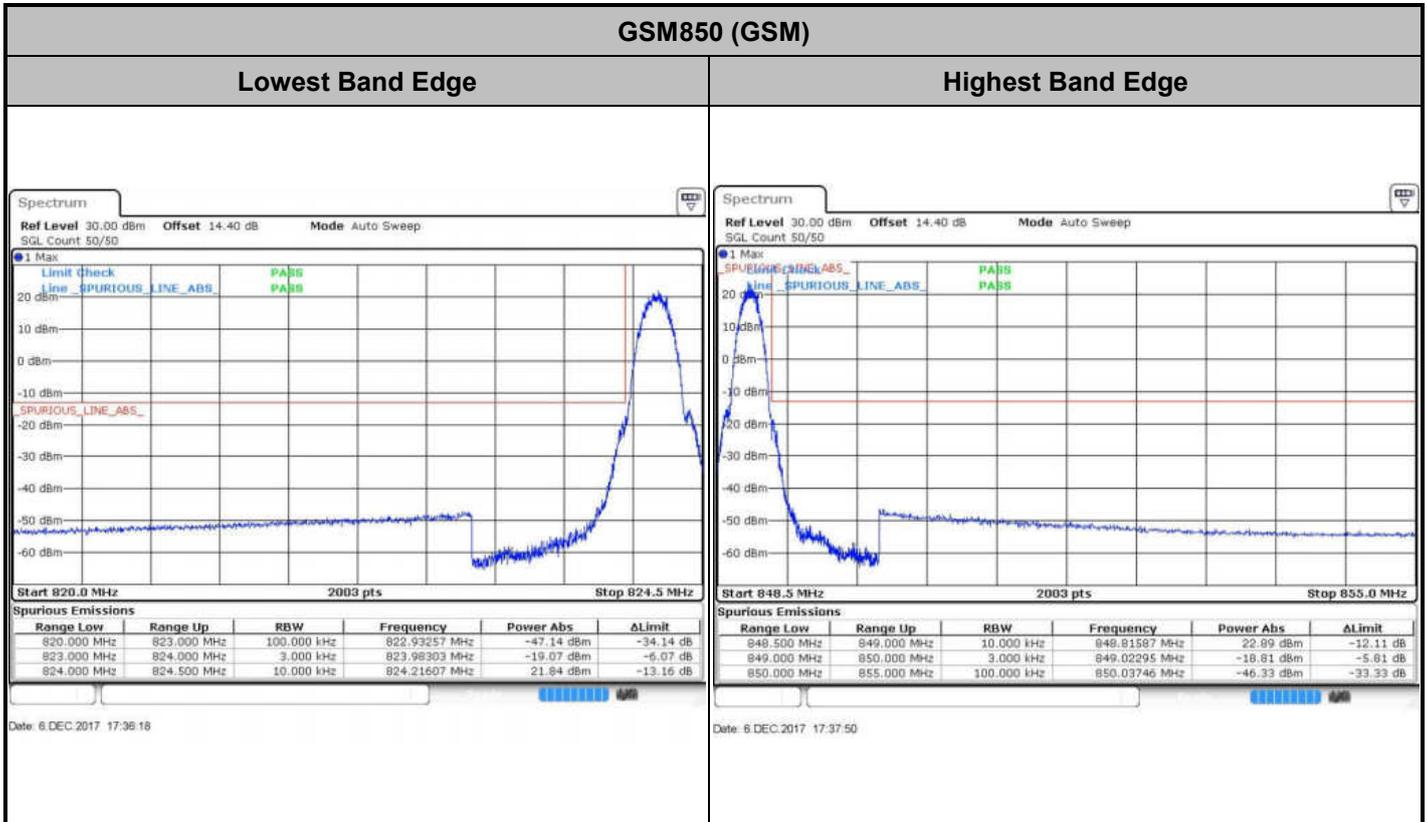



GSM1900 (GSM)

Lowest Band Edge

Highest Band Edge

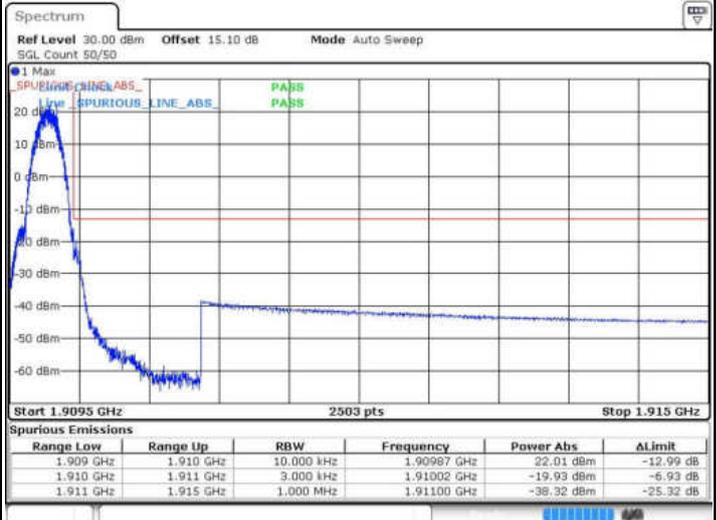
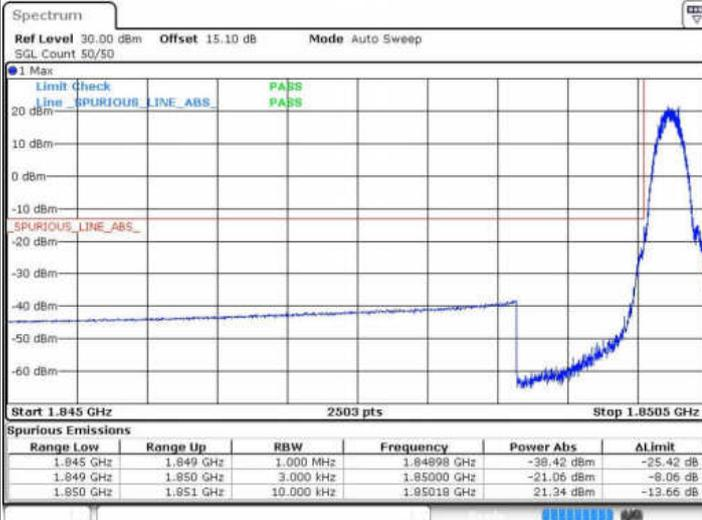

Date: 6 DEC.2017 18:18:29

Date: 6 DEC.2017 18:20:02

GSM1900 (EDGE class 8)

Lowest Band Edge

Highest Band Edge

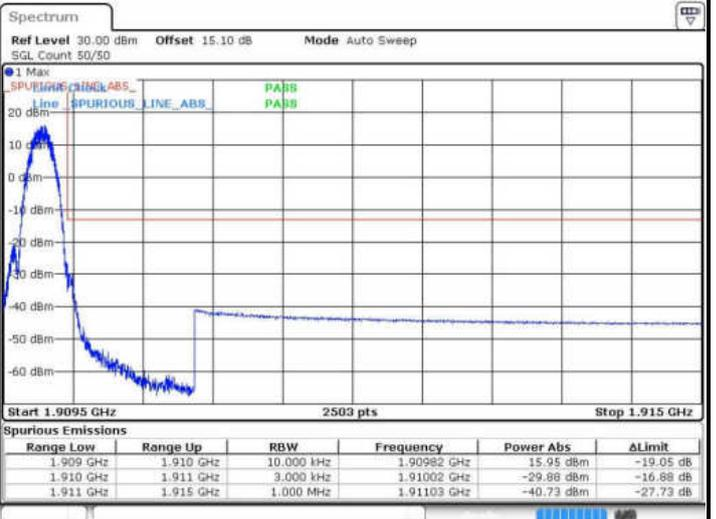
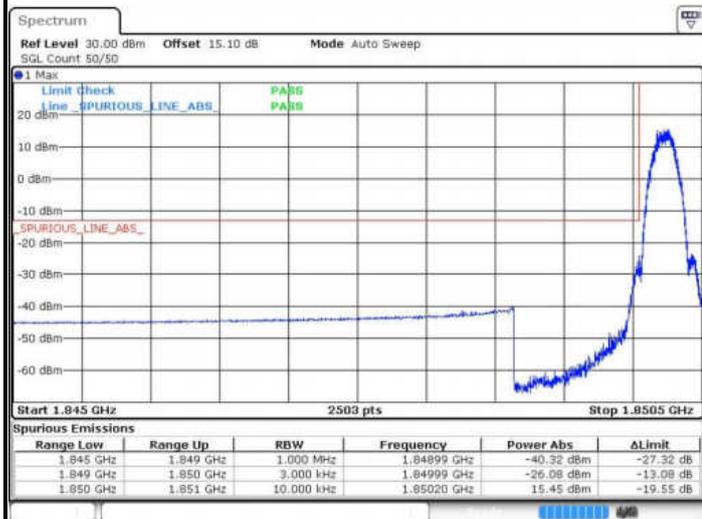

Date: 6 DEC.2017 18:33:46

Date: 6 DEC.2017 18:35:17



WCDMA Band V (RMC 12.2Kbps)

Lowest Band Edge

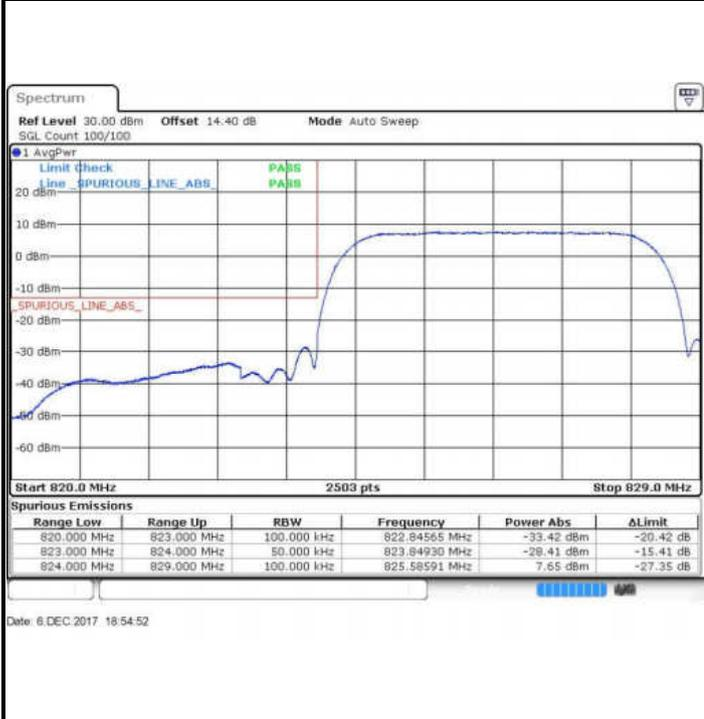

Highest Band Edge

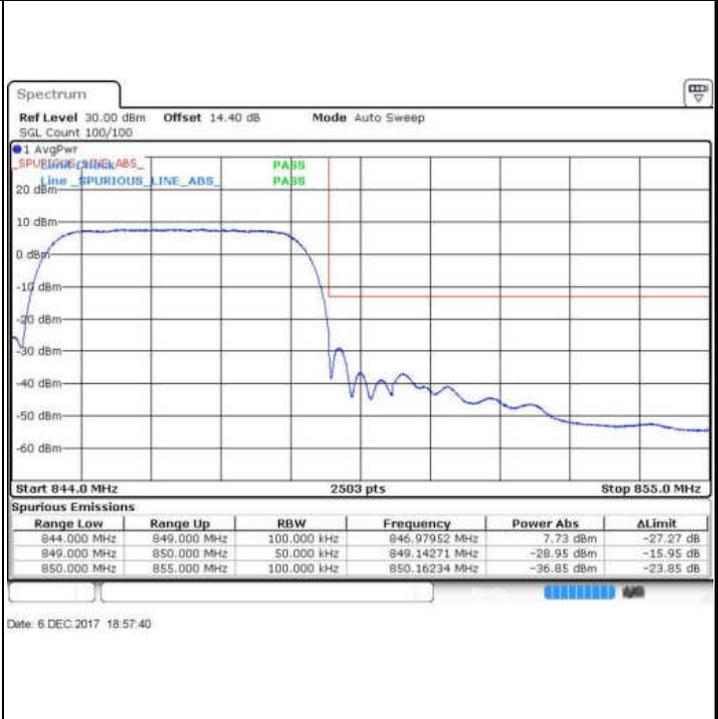

WCDMA Band II (RMC 12.2Kbps)

Lowest Band Edge

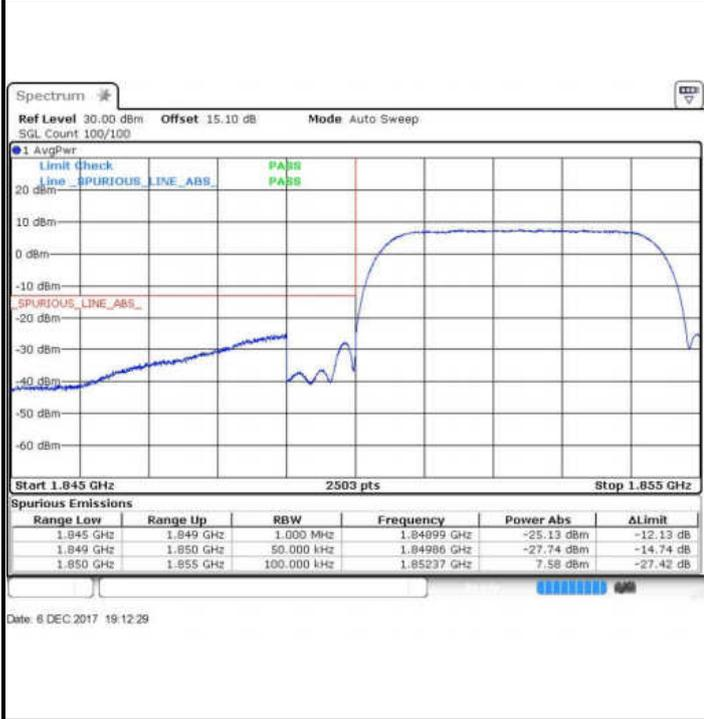

Highest Band Edge

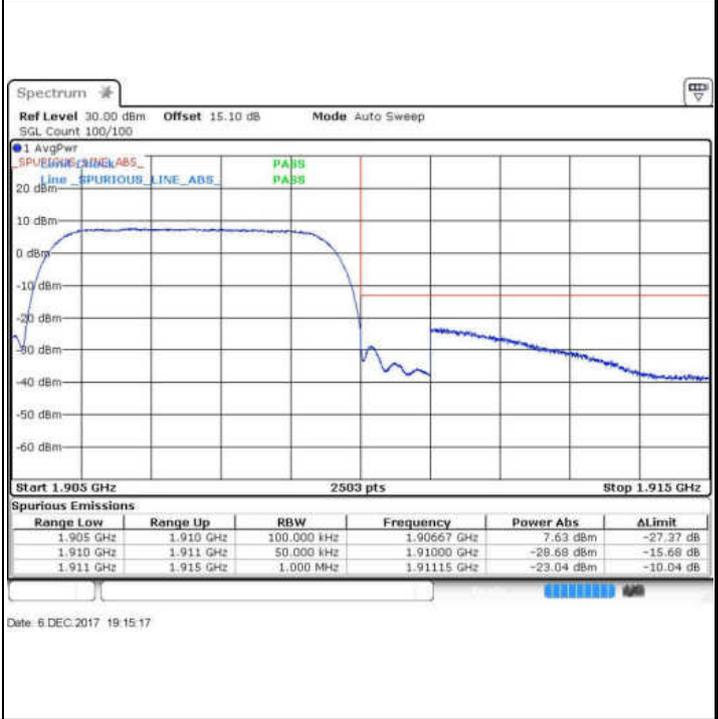

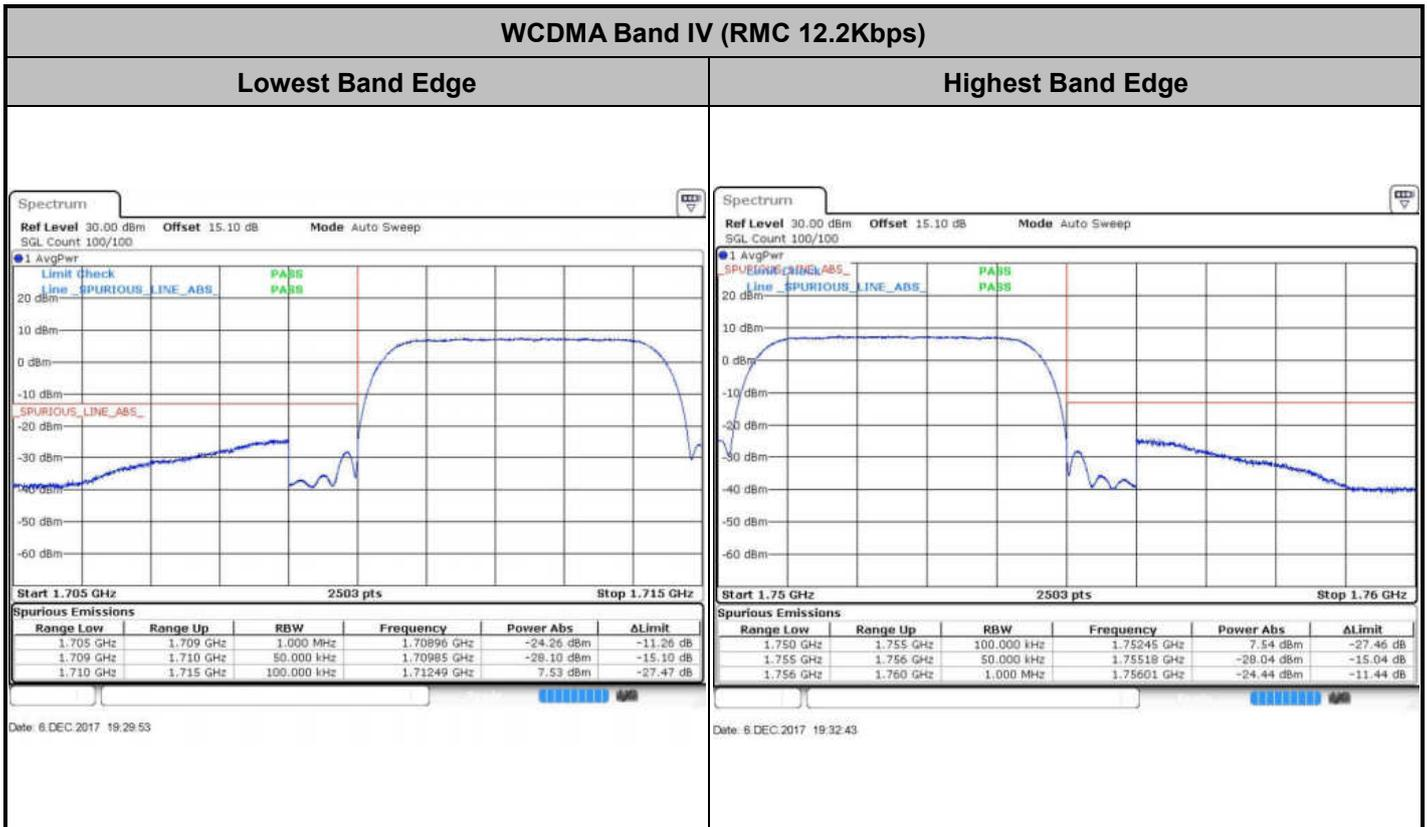



Conducted Spurious Emission

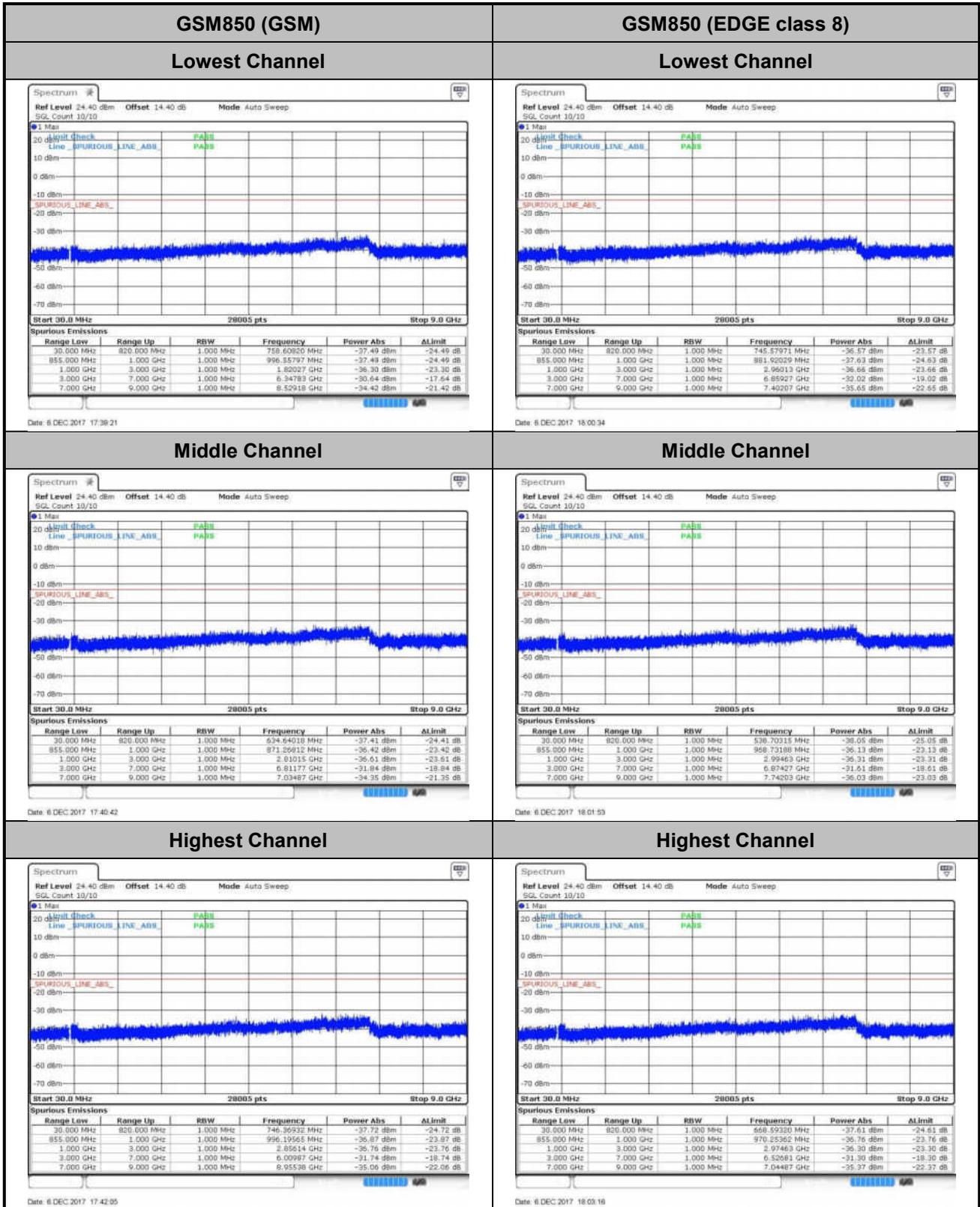



GSM1900 (GSM)

Lowest Channel

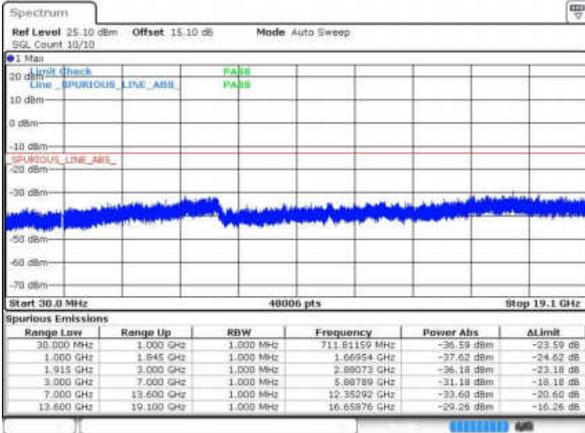

Date: 8 DEC 2017 18:21:22

GSM1900 (EDGE class 8)

Lowest Channel

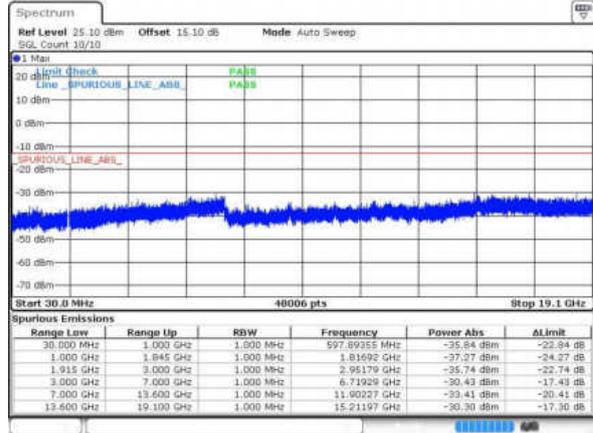

Date: 8 DEC 2017 18:36:40

Middle Channel

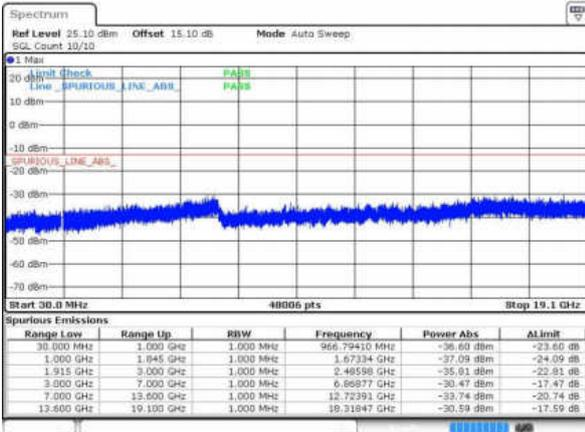

Date: 8 DEC 2017 18:22:46

Middle Channel

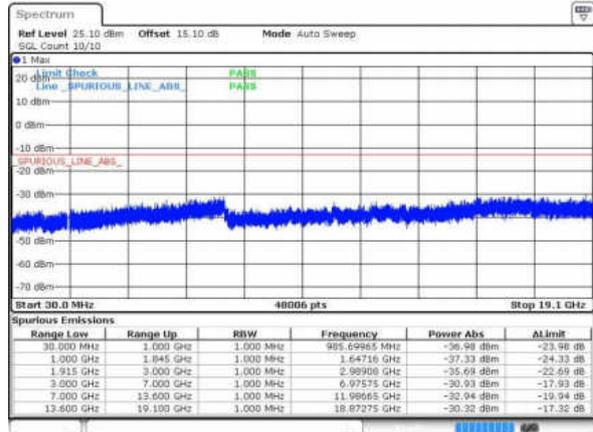

Date: 8 DEC 2017 18:38:07

Highest Channel

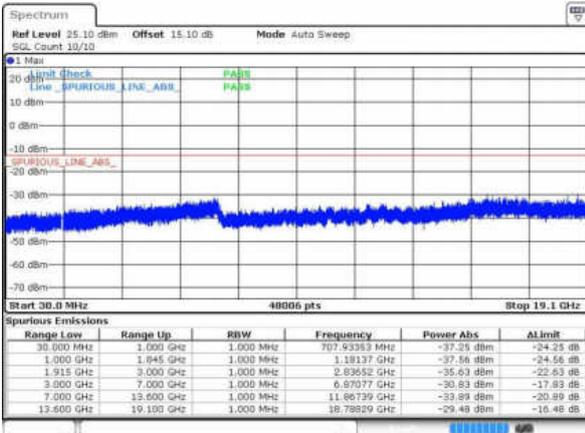

Date: 8 DEC 2017 18:24:08

Highest Channel

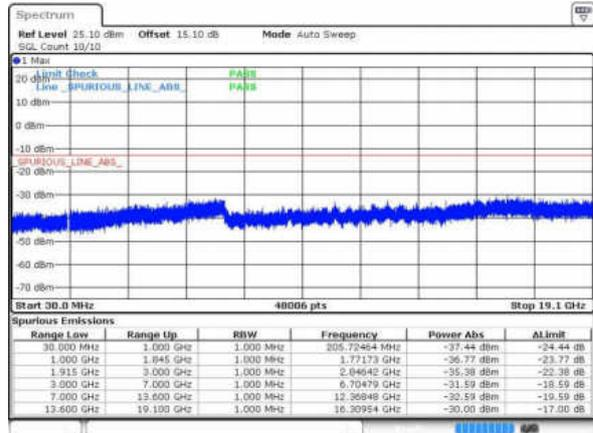

Date: 8 DEC 2017 18:40:03



WCDMA Band V (RMC 12.2Kbps)

Lowest Channel

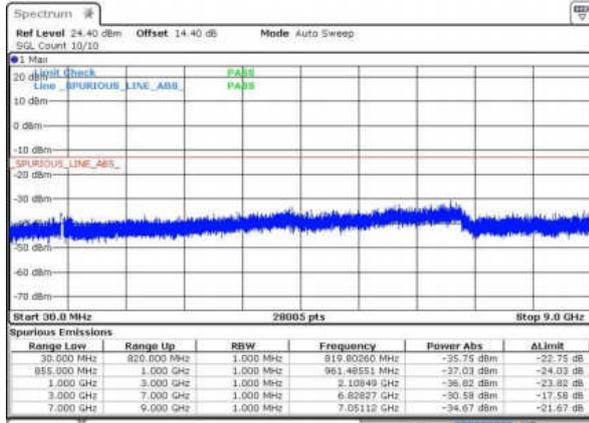

Date: 8 DEC 2017 18:59:21

WCDMA Band II (RMC 12.2Kbps)

Lowest Channel

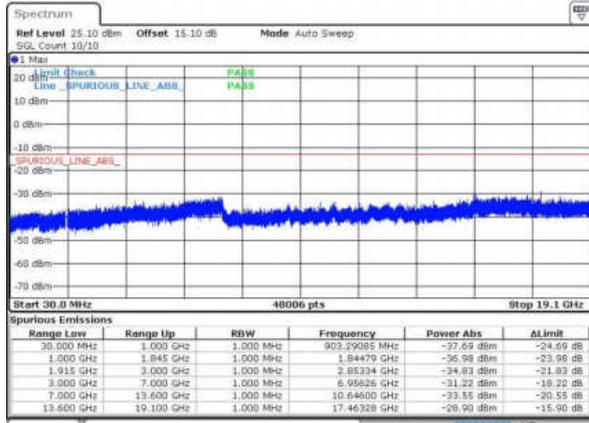

Date: 8 DEC 2017 19:16:48

Middle Channel

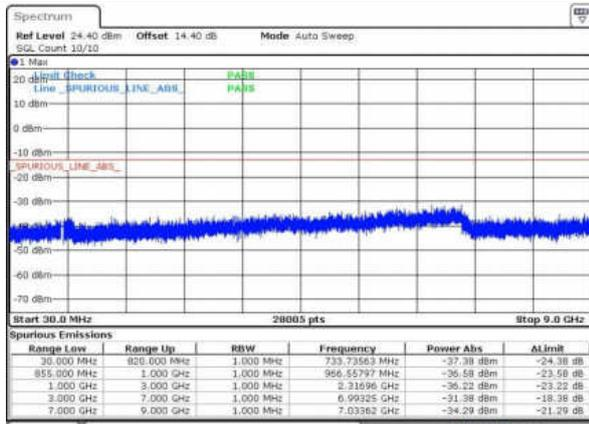

Date: 8 DEC 2017 19:06:43

Middle Channel

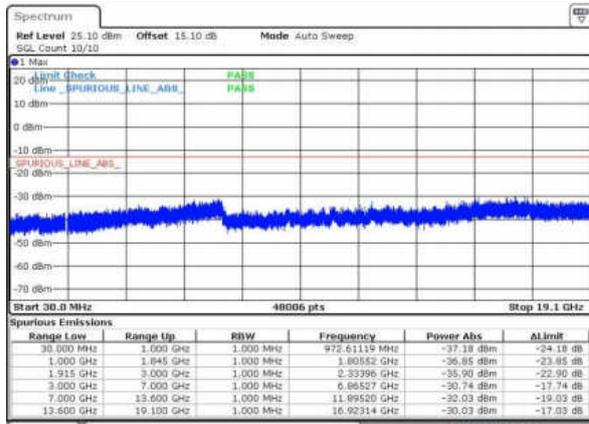

Date: 8 DEC 2017 19:18:08

Highest Channel

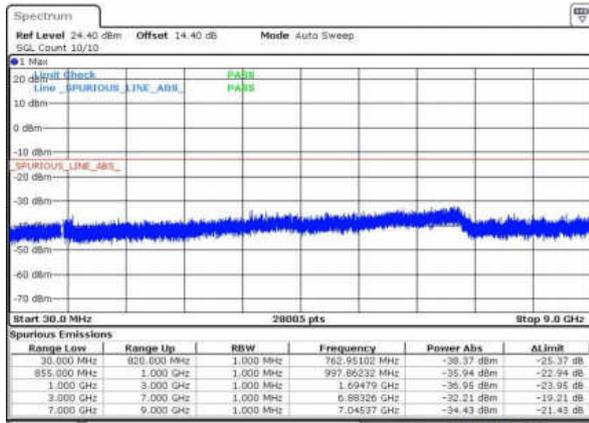

Date: 8 DEC 2017 19:02:06

Highest Channel

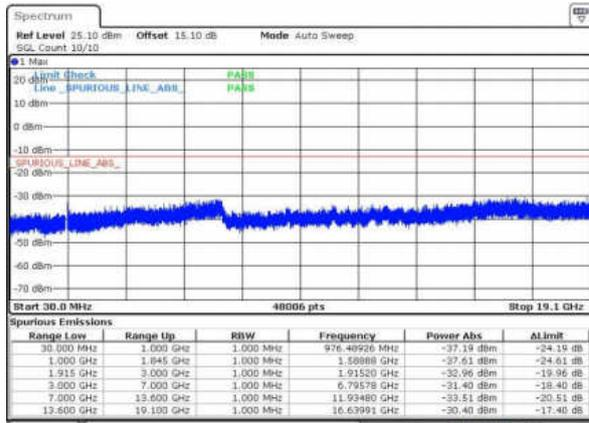

Date: 8 DEC 2017 19:19:31



WCDMA Band IV (RMC 12.2Kbps)

Lowest Channel

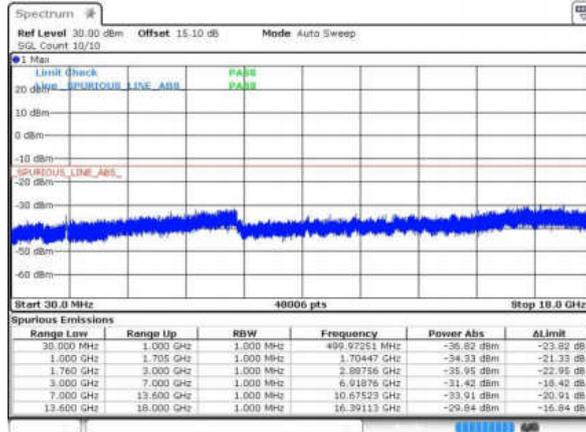

Date: 6 DEC 2017 19:34:20

Middle Channel

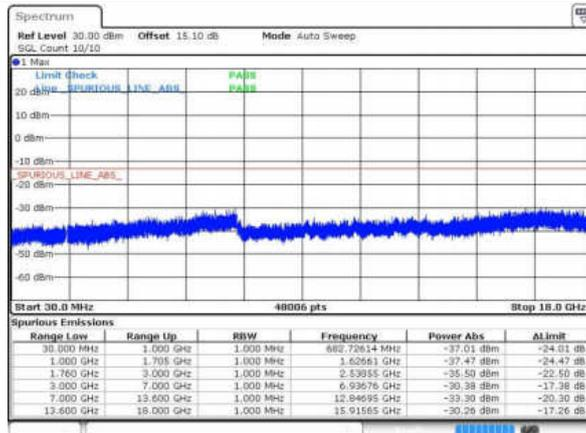

Date: 6 DEC 2017 19:36:12

Highest Channel

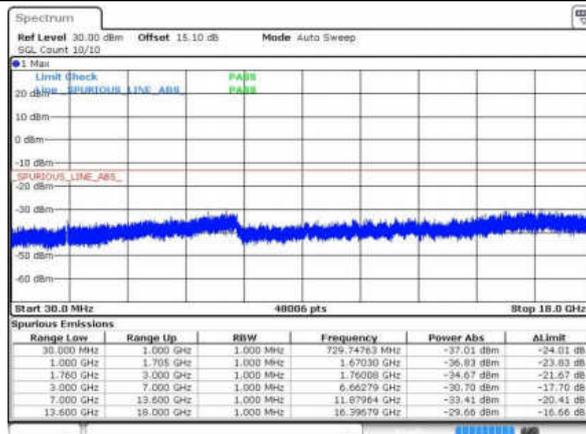

Date: 6 DEC 2017 19:37:38



Frequency Stability

Test Conditions	Middle Channel	GSM850 (GSM)	GSM850 (EDGE class 8)	Limit 2.5ppm
Temperature (°C)	Voltage (Volt)	Deviation (ppm)		Result
50	Normal Voltage	0.0108	0.0275	PASS
40	Normal Voltage	0.0036	0.0239	
30	Normal Voltage	0.0132	0.0084	
20(Ref.)	Normal Voltage	0.0000	0.0000	
10	Normal Voltage	0.0167	0.0167	
0	Normal Voltage	0.0072	0.0167	
-10	Normal Voltage	0.0203	0.0227	
-20	Normal Voltage	0.0155	0.0060	
-30	Normal Voltage	0.0143	0.0108	
20	Maximum Voltage	0.0096	0.0132	
20	Normal Voltage	0.0120	0.0203	
20	Battery End Point	0.0191	0.0036	

Note: Normal Voltage = 3.8 V. ; Battery End Point (BEP) =3.6 V. ; Maximum Voltage =4.4 V



Test Conditions	Middle Channel	GSM1900 (GSM)	GSM1900 (EDGE class 8)	Limit Note 2.
Temperature (°C)	Voltage (Volt)	Deviation (ppm)		Result
50	Normal Voltage	0.0053	0.0181	PASS
40	Normal Voltage	0.0005	0.0133	
30	Normal Voltage	0.0117	0.0027	
20(Ref.)	Normal Voltage	0.0000	0.0000	
10	Normal Voltage	0.0133	0.0106	
0	Normal Voltage	0.0106	0.0149	
-10	Normal Voltage	0.0090	0.0170	
-20	Normal Voltage	0.0027	0.0122	
-30	Normal Voltage	0.0128	0.0117	
20	Maximum Voltage	0.0069	0.0021	
20	Normal Voltage	0.0016	0.0138	
20	Battery End Point	0.0128	0.0027	

Note:

1. Normal Voltage = 3.8 V. ; Battery End Point (BEP) =3.6 V. ; Maximum Voltage =4.4 V
2. The frequency fundamental emissions stay within the authorized frequency block based on the frequency deviation measured is small.



Test Conditions	Middle Channel	WCDMA Band V (RMC 12.2Kbps)	Limit 2.5ppm
Temperature (°C)	Voltage (Volt)	Deviation (ppm)	Result
50	Normal Voltage	0.0084	PASS
40	Normal Voltage	0.0287	
30	Normal Voltage	0.0024	
20(Ref.)	Normal Voltage	0.0000	
10	Normal Voltage	0.0359	
0	Normal Voltage	0.0251	
-10	Normal Voltage	0.0060	
-20	Normal Voltage	0.0299	
-30	Normal Voltage	0.0036	
20	Maximum Voltage	0.0012	
20	Normal Voltage	0.0239	
20	Battery End Point	0.0263	

Note: Normal Voltage = 3.8 V. ; Battery End Point (BEP) =3.6 V. ; Maximum Voltage =4.4 V.

Test Conditions	Middle Channel	WCDMA Band II (RMC 12.2Kbps)	Limit Note 2.
Temperature (°C)	Voltage (Volt)	Deviation (ppm)	Result
50	Normal Voltage	0.0005	PASS
40	Normal Voltage	0.0101	
30	Normal Voltage	0.0112	
20(Ref.)	Normal Voltage	0.0000	
10	Normal Voltage	0.0165	
0	Normal Voltage	0.0048	
-10	Normal Voltage	0.0122	
-20	Normal Voltage	0.0154	
-30	Normal Voltage	0.0021	
20	Maximum Voltage	0.0021	
20	Normal Voltage	0.0096	
20	Battery End Point	0.0032	

Note:

1. Normal Voltage = 3.8 V. ; Battery End Point (BEP) =3.6 V. ; Maximum Voltage =4.4 V.
2. The frequency fundamental emissions stay within the authorized frequency block based on the frequency deviation measured is small.



Test Conditions	Middle Channel	WCDMA Band IV (RMC 12.2Kbps)	Limit Note 2.
Temperature (°C)	Voltage (Volt)	Deviation (ppm)	Result
50	Normal Voltage	0.0035	PASS
40	Normal Voltage	0.0029	
30	Normal Voltage	0.0150	
20(Ref.)	Normal Voltage	0.0000	
10	Normal Voltage	0.0023	
0	Normal Voltage	0.0127	
-10	Normal Voltage	0.0035	
-20	Normal Voltage	0.0144	
-30	Normal Voltage	0.0046	
20	Maximum Voltage	0.0017	
20	Normal Voltage	0.0133	
20	Battery End Point	0.0035	

Note:

1. Normal Voltage = 3.8 V. ; Battery End Point (BEP) =3.6 V. ; Maximum Voltage =4.4 V.
2. The frequency fundamental emissions stay within the authorized frequency block based on the frequency deviation measured is small.



Appendix B. Test Results of Radiated Test

Radiated Spurious Emission

GPRS 850 (GSM)									
Channel	Frequency (MHz)	ERP (dBm)	Limit (dBm)	Over Limit (dB)	SPA Reading (dBm)	S.G. Power (dBm)	TX Cable loss (dB)	TX Antenna Gain (dBi)	Polarization (H/V)
Middle	1674	-55.92	-13	-42.92	-56.24	-57.83	1.14	5.20	H
	2510	-42.58	-13	-29.58	-49.36	-45.21	1.12	5.90	H
	3345	-62.00	-13	-49.00	-66.12	-65.21	1.34	6.70	H
	1674	-53.35	-13	-40.35	-53.1	-55.26	1.14	5.20	V
	2510	-45.62	-13	-32.62	-51.97	-48.25	1.12	5.90	V
	3345	-61.65	-13	-48.65	-66.79	-64.86	1.34	6.70	V

Remark: Spurious emissions within 30-1000MHz were found more than 20dB below limit line.

EDGE 850 (GSM)									
Channel	Frequency (MHz)	ERP (dBm)	Limit (dBm)	Over Limit (dB)	SPA Reading (dBm)	S.G. Power (dBm)	TX Cable loss (dB)	TX Antenna Gain (dBi)	Polarization (H/V)
Middle	1672	-57.87	-13	-44.87	-58.19	-59.78	1.14	5.20	H
	2510	-56.49	-13	-43.49	-60.79	-59.12	1.12	5.90	H
	3345	-62.85	-13	-49.85	-66.97	-66.06	1.34	6.70	H
	1674	-53.12	-13	-40.12	-52.93	-55.03	1.14	5.20	V
	2510	-59.22	-13	-46.22	-62.29	-61.85	1.12	5.90	V
	3345	-61.84	-13	-48.84	-66.98	-65.05	1.34	6.70	V

Remark: Spurious emissions within 30-1000MHz were found more than 20dB below limit line.



GPRS 1900 (GSM)									
Channel	Frequency (MHz)	EIRP (dBm)	Limit (dBm)	Over Limit (dB)	SPA Reading (dBm)	S.G. Power (dBm)	TX Cable loss (dB)	TX Antenna Gain (dBi)	Polarization (H/V)
Middle	3759	-40.30	-13	-27.30	-51.42	-45.47	1.83	7.00	H
	5640	-57.02	-13	-44.02	-69.19	-64.64	2.18	9.80	H
	7521	-51.49	-13	-38.49	-68.72	-61.16	2.53	12.20	H
	3759	-42.72	-13	-29.72	-54.97	-47.89	1.83	7.00	V
	5640	-54.41	-13	-41.41	-68.58	-62.03	2.18	9.80	V
	7521	-49.20	-13	-36.20	-70.3	-58.87	2.53	12.20	V

Remark: Spurious emissions within 30-1000MHz were found more than 20dB below limit line.

EDGE1900 (GSM)									
Channel	Frequency (MHz)	EIRP (dBm)	Limit (dBm)	Over Limit (dB)	SPA Reading (dBm)	S.G. Power (dBm)	TX Cable loss (dB)	TX Antenna Gain (dBi)	Polarization (H/V)
Middle	3759	-56.34	-13	-43.34	-63.72	-61.51	1.83	7.00	H
	5640	-57.28	-13	-44.28	-69.45	-64.90	2.18	9.80	H
	7521	-51.60	-13	-38.60	-68.83	-61.27	2.53	12.20	H
	3759	-58.93	-13	-45.93	-67.78	-64.10	1.83	7.00	V
	5640	-55.17	-13	-42.17	-69.34	-62.79	2.18	9.80	V
	7521	-49.16	-13	-36.16	-70.26	-58.83	2.53	12.20	V

Remark: Spurious emissions within 30-1000MHz were found more than 20dB below limit line.



WCDMA Band II (RMC 12.2Kbps)									
Channel	Frequency (MHz)	EIRP (dBm)	Limit (dBm)	Over Limit (dB)	SPA Reading (dBm)	S.G. Power (dBm)	TX Cable loss (dB)	TX Antenna Gain (dBi)	Polarization (H/V)
Middle	3759	-58.80	-13	-45.80	-66.18	-63.97	1.83	7.00	H
	5640	-56.14	-13	-43.14	-68.31	-63.76	2.18	9.80	H
	7521	-52.70	-13	-39.70	-69.93	-62.37	2.53	12.20	H
	3762	-54.00	-13	-41.00	-62.85	-59.17	1.83	7.00	V
	5640	-55.04	-13	-42.04	-69.21	-62.66	2.18	9.80	V
	7521	-48.52	-13	-35.52	-69.62	-58.19	2.53	12.20	V

Remark: Spurious emissions within 30-1000MHz were found more than 20dB below limit line.

WCDMA Band IV(RMC 12.2Kbps)									
Channel	Frequency (MHz)	EIRP (dBm)	Limit (dBm)	Over Limit (dB)	SPA Reading (dBm)	S.G. Power (dBm)	TX Cable loss (dB)	TX Antenna Gain (dBi)	Polarization (H/V)
Middle	3465	-57.57	-13	-44.57	-65.85	-62.71	1.81	6.95	H
	5199	-54.00	-13	-41.00	-68.56	-61.07	2.23	9.30	H
	6930	-48.76	-13	-35.76	-68.11	-57.04	2.60	10.88	H
	3465	-60.48	-13	-47.48	-66.28	-65.62	1.81	6.95	V
	5199	-53.82	-13	-40.82	-68.12	-60.89	2.23	9.30	V
	6930	-50.49	-13	-37.49	-69.03	-58.77	2.6	10.88	V

Remark: Spurious emissions within 30-1000MHz were found more than 20dB below limit line.

WCDMA Band V (RMC 12.2Kbps)									
Channel	Frequency (MHz)	ERP (dBm)	Limit (dBm)	Over Limit (dB)	SPA Reading (dBm)	S.G. Power (dBm)	TX Cable loss (dB)	TX Antenna Gain (dBi)	Polarization (H/V)
Middle	1672	-62.36	-13	-49.36	-62.68	-64.27	1.14	5.20	H
	2509	-60.61	-13	-47.61	-64.91	-63.24	1.12	5.90	H
	3345	-61.80	-13	-48.80	-65.92	-65.01	1.34	6.70	H
	1672	-62.20	-13	-49.20	-61.3	-64.11	1.14	5.20	V
	2509	-61.18	-13	-48.18	-64.25	-63.81	1.12	5.90	V
	3345	-61.10	-13	-48.10	-66.24	-64.31	1.34	6.70	V

Remark: Spurious emissions within 30-1000MHz were found more than 20dB below limit line.