



# FCC RF Test Report

**APPLICANT** : Motorola Mobility LLC  
**EQUIPMENT** : Mobile Cellular Phone  
**BRAND NAME** : Motorola  
**MODEL NAME** : XT1929-5  
**FCC ID** : IHDT56XE5  
**STANDARD** : 47 CFR Part 2, 22(H), 24(E), 27  
**CLASSIFICATION** : PCS Licensed Transmitter Held to Ear (PCE)

This is a variant report. The product was received on Jan. 18, 2018 and completely tested on Mar. 08, 2018. We, SPORTON INTERNATIONAL Inc., would like to declare that the tested sample has been evaluated in accordance with the test procedures given in ANSI / TIA-603-E and the testing has shown the tested sample to be in compliance with the applicable technical standards.

The test results in this report apply exclusively to the tested model / sample. Without written approval of SPORTON INTERNATIONAL INC., the test report shall not be reproduced except in full.

Reviewed by: Joseph Lin / Supervisor

Approved by: Jones Tsai / Manager



## **SPORTON INTERNATIONAL INC.**

**No. 52, Hwa Ya 1<sup>st</sup> Rd., Hwa Ya Technology Park, Kwei-Shan District, Tao Yuan City, Taiwan, R.O.C.**

SPORTON INTERNATIONAL INC.

TEL : 886-3-327-3456

FAX : 886-3-328-4978

FCC ID: IHDT56XE5

Page Number : 1 of 20

Report Issued Date : Mar. 14, 2018

Report Version : Rev. 01

Report Template No.: BU5-FGLTE Version 2.0



# TABLE OF CONTENTS

**REVISION HISTORY.....3**

**SUMMARY OF TEST RESULT .....4**

**1 GENERAL DESCRIPTION .....5**

    1.1 Applicant .....5

    1.2 Manufacturer.....5

    1.3 Product Feature of Equipment Under Test.....5

    1.4 Product Specification of Equipment Under Test.....7

    1.5 Modification of EUT .....7

    1.6 Emission Designator.....8

    1.7 Testing Location .....9

    1.8 Applicable Standards.....9

**2 TEST CONFIGURATION OF EQUIPMENT UNDER TEST .....10**

    2.1 Test Mode.....10

    2.2 Connection Diagram of Test System.....11

    2.3 Support Unit used in test configuration and system .....12

    2.4 Frequency List of Low/Middle/High Channels .....13

**3 CONDUCTED TEST ITEMS .....14**

    3.1 Measuring Instruments .....14

    3.2 Test Setup .....14

    3.3 Test Result of Conducted Test .....14

    3.4 Conducted Output Power and ERP/EIRP .....15

    3.5 Frequency Stability .....16

**4 RADIATED TEST ITEMS .....17**

    4.1 Measuring Instruments .....17

    4.2 Test Setup .....17

    4.3 Test Result of Radiated Test .....17

    4.4 Radiated Spurious Emission .....18

**5 LIST OF MEASURING EQUIPMENT .....19**

**6 UNCERTAINTY OF EVALUATION .....20**

**APPENDIX A. TEST RESULTS OF CONDUCTED TEST**

**APPENDIX B. TEST RESULTS OF ERP/EIRP AND RADIATED TEST**





## SUMMARY OF TEST RESULT

Report Section	FCC Rule	Description	Limit	Result	Remark
3.4	§2.1046	Conducted Output Power	Reporting Only	PASS	-
	§22.913(a)(2)	Effective Radiated Power (Band 5)	ERP < 7 Watt		
	§27.50(h)(2)	Equivalent Isotropic Radiated Power (Band 7)	EIRP < 2Watt		
3.5	N/A	Peak-to-Average Ratio	<13 dB	Not required	-
3.6	§2.1049	Occupied Bandwidth	Reporting Only	Not required	-
3.7	§2.1051 §22.917(a)	Conducted Band Edge Measurement (Band 5)	< 43+10log <sub>10</sub> (P[Watts])	Not required	-
	§27.53(m)(4)	Conducted Band Edge Measurement (Band 7)	§27.53(m)(4)		
3.8	§2.1051 §22.917(a)	Conducted Spurious Emission (Band 5)	< 43+10log <sub>10</sub> (P[Watts])	Not required	-
	§2.1051 §27.53(m)(4)	Conducted Spurious Emission (Band 7)	< 55+10log <sub>10</sub> (P[Watts])		
3.9	§2.1055 §22.355	Frequency Stability Temperature & Voltage	< 2.5 ppm for Part 22	PASS	-
	§2.1055 §27.54		Within Authorized Band		
4.4	§2.1053 §22.917(a)	Radiated Spurious Emission (Band 5)	< 43+10log <sub>10</sub> (P[Watts])	PASS	Under limit 6.73 dB at 12840.000 MHz
	§2.1053 §27.53(m)(4)	Radiated Spurious Emission (Band 7)	< 55+10log <sub>10</sub> (P[Watts])		
<b>Note:</b> Not required means after assessing, test items are not necessary to carry out.					



# 1 General Description

## 1.1 Applicant

Motorola Mobility LLC  
222 W,Merchandise Mart Plaza, Chicago IL 60654 USA

## 1.2 Manufacturer

Motorola Mobility LLC  
222 W,Merchandise Mart Plaza, Chicago IL 60654 USA

## 1.3 Product Feature of Equipment Under Test

Product Feature	
Equipment	Mobile Cellular Phone
Brand Name	Motorola
Model Name	XT1929-5
FCC ID	IHDT56XE5
IMEI Code	Conducted : IMEI 1: 354106090006195 IMEI 2: 354106090006203
	Radiation : IMEI 1: 354106090008035 IMEI 2: 354106090008043
EUT supports Radios application	GSM/EGPRS/WCDMA/HSPA/LTE/GNSS/NFC WLAN 11b/g/n HT20 WLAN 11a/n HT20/HT40 WLAN 11ac VHT20/VHT40/VHT80 Bluetooth BR/EDR/LE
HW Version	DVT2
EUT Stage	Identical Prototype

**Remark:**

1. The above EUT's information was declared by manufacturer. Please refer to the specifications or user's manual for more detailed description.
2. This is a variant report. Except Radiation Spurious Emission, Conducted Output Power, Equivalent Isotropic Radiated Power, Effective Radiated Power, FG811821-04B report reuses conducted test data for LTE Band 5 from the FG811821-02B report and FG811821-04B report reuses test data for LTE Band 7 from the FG811821B report.



Accessory List	
AC Adapter 1	Brand Name : Motorola
	Model Name : SC-28 SPN5997A
	Manufacturer : Salom
AC Adapter 2	Brand Name : Motorola
	Model Name : SC-28 SPN5976A
	Manufacturer : Salom
AC Adapter 3	Brand Name : Motorola
	Model Name : SC-28 SPN5998A
	Manufacturer : Cliptech Manufacturer : Chenyang
Battery	Brand Name : Motorola
	Model Name : JS40
	Manufacturer : SUNWODA
Earphone	Brand Name : Motorola
	Model Name : SH38C16618
C2Audio Cable 1	Brand Name : Motorola
	Model Name : SC18C27844
	Manufacturer : Luxshare
C2Audio Cable 2	Brand Name : Motorola
	Model Name : SC18C27845
	Manufacturer : Cabletech
USB Cable 1	Brand Name : Cabletech
	Model Name : SKN6473A
USB Cable 2	Brand Name : FOXLINK
	Model Name : SKN6473A 17195-C 0403532
USB Cable 3	Brand Name : SAIBAO
	Model Name : SKN6473A 17214-C 1127044
USB Cable 4	Brand Name : Luxshare
	Model Name : SKN6473A 17227-C 1126538



### 1.4 Product Specification of Equipment Under Test

Standards-related Product Specification	
<b>Tx Frequency</b>	LTE Band 5: 824.7 MHz ~ 848.3 MHz LTE Band 7: 2502.5 MHz ~ 2567.5 MHz
<b>Rx Frequency</b>	LTE Band 5: 869.7 MHz ~ 893.3 MHz LTE Band 7: 2622.5 MHz ~ 2687.5 MHz
<b>Bandwidth</b>	LTE Band 5: 1.4MHz / 3MHz / 5MHz / 10MHz LTE Band 7: 5MHz / 10MHz / 15MHz / 20MHz
<b>Maximum Output Power to Antenna</b>	LTE Band 5: 22.94 dBm LTE Band 7: 22.24 dBm
<b>Antenna Type</b>	Fixed Internal Antenna
<b>Antenna Gain</b>	<Main Antenna> LTE Band 5: -5.6 dBi LTE Band 7: 0.3 dBi <Aux. Antenna> LTE Band 7: -4.7 dBi
<b>Type of Modulation</b>	QPSK / 16QAM / 64QAM

### 1.5 Modification of EUT

No modifications are made to the EUT during all test items.



## 1.6 Emission Designator

<For Main Antenna>

LTE Band 5		QPSK			16QAM			64QAM		
BW (MHz)	Frequency Range (MHz)	Emission Designator (99%OBW)	Frequency Tolerance (ppm)	Maximum ERP(W)	Emission Designator (99%OBW)	Frequency Tolerance (ppm)	Maximum ERP(W)	Emission Designator (99%OBW)	Frequency Tolerance (ppm)	Maximum EIRP(W)
1.4	824.7 ~ 848.3	-	-	0.0325	-	-	0.0279	-	-	0.0218
3	825.5 ~ 847.5	-	-	0.0311	-	-	0.0269	-	-	0.0264
5	826.5 ~ 846.5	-	-	0.0308	-	-	0.0265	-	-	0.0207
10	829.0 ~ 844.0	-	-	0.0330	-	-	0.0277	-	-	0.0216
LTE Band 7		QPSK			16QAM			64QAM		
BW (MHz)	Frequency Range (MHz)	Emission Designator (99%OBW)	Frequency Tolerance (ppm)	Maximum EIRP(W)	Emission Designator (99%OBW)	Frequency Tolerance (ppm)	Maximum EIRP(W)	Emission Designator (99%OBW)	Frequency Tolerance (ppm)	Maximum EIRP(W)
5	2502.5 ~ 2567.5	-	-	0.1782	-	-	0.1528	-	-	0.1191
10	2505.0 ~ 2565.0	-	-	0.1778	-	-	0.1521	-	-	0.1186
15	2507.5 ~ 2562.5	-	-	0.1786	-	-	0.1524	-	-	0.1189
20	2510.0 ~ 2560.0	-	-	0.1795	-	-	0.1510	-	-	0.1183

<For Aux. Antenna>

LTE Band 7		QPSK	16QAM	64QAM
BW (MHz)	Frequency Range (MHz)	Maximum EIRP(W)	Maximum EIRP(W)	Maximum EIRP(W)
5	2502.5 ~ 2567.5	0.0564	0.0483	0.0377
10	2505.0 ~ 2565.0	0.0562	0.0481	0.0375
15	2507.5 ~ 2562.5	0.0565	0.0482	0.0376
20	2510.0 ~ 2560.0	0.0568	0.0478	0.0374





### 1.7 Testing Location

Sporton Lab is accredited to ISO 17025 by Taiwan Accreditation Foundation (TAF code : 1190) and the FCC designation No. TW1190 and TW0007 under the FCC 2.948(e) by Mutual Recognition Agreement (MRA) in FCC Test.

<b>Test Site</b>	SPORTON INTERNATIONAL INC.
<b>Test Site Location</b>	No. 52, Hwa Ya 1 <sup>st</sup> Rd., Hwa Ya Technology Park, Kwei-Shan District, Tao Yuan City, Taiwan, R.O.C. TEL: +886-3-327-3456 FAX: +886-3-328-4978
<b>Test Site No.</b>	<b>Sporton Site No.</b> TH05HY

**Note:** The test site complies with ANSI C63.4 2014 requirement.

<b>Test Site</b>	SPORTON INTERNATIONAL INC.
<b>Test Site Location</b>	No.58, Aly. 75, Ln. 564, Wenhua 3rd Rd. Guishan Dist, Taoyuan City, Taiwan (R.O.C.) TEL: +886-3-327-0868 FAX: +886-3-327-0855
<b>Test Site No.</b>	<b>Sporton Site No.</b> 03CH13-HY

**Note:** The test site complies with ANSI C63.4 2014 requirement.

### 1.8 Applicable Standards

According to the specifications of the manufacturer, the EUT must comply with the requirements of the following standards:

- ♦ 47 CFR Part 2, 22(H), 24(E), 27
- ♦ ANSI / TIA-603-E
- ♦ FCC KDB 971168 D01 Power Meas. License Digital Systems v03
- ♦ FCC KDB 412172 D01 Determining ERP and EIRP v01r01

**Remark:**

1. All test items were verified and recorded according to the standards and without any deviation during the test.
2. This EUT has also been tested and complied with the requirements of FCC Part 15, Subpart B, recorded in a separate test report.



## 2 Test Configuration of Equipment Under Test

### 2.1 Test Mode

Antenna port conducted and radiated test items listed below are performed according to KDB 971168 D01 Power Meas. License Digital Systems v03 with maximum output power.

Radiated measurements are performed by rotating the EUT in three different orthogonal test planes to find the maximum emission.

Test Items	Band	Bandwidth (MHz)						Modulation			RB #			Test Channel		
		1.4	3	5	10	15	20	QPSK	16QAM	64QAM	1	Half	Full	L	M	H
Max. Output Power	5	v	v	v	v	-	-	v	v	v	v	v	v	v	v	v
	7	-	-	v	v	v	v	v	v	v	v	v	v	v	v	v
E.R.P / E.I.R.P	5	v	v	v	v	-	-	v	v	v	v	v		v	v	v
	7	-	-	v	v	v	v	v	v	v	v			v	v	v
Radiated Spurious Emission	5	Worst Case											v	v	v	
	7	Worst Case											v	v	v	
Note	<ol style="list-style-type: none"> <li>The mark "v" means that this configuration is chosen for testing</li> <li>The mark "-" means that this bandwidth is not supported.</li> <li>The device is investigated from 30MHz to 10 times of fundamental signal for radiated spurious emission test under different RB size/offset and modulations in exploratory test. Subsequently, only the worst case emissions are reported.</li> <li>All the radiated test cases were performance with Adapter 1, USB Cable 1, and C2Audio Cable 1.</li> </ol>															

## 2.2 Connection Diagram of Test System

<EUT with Standalone>

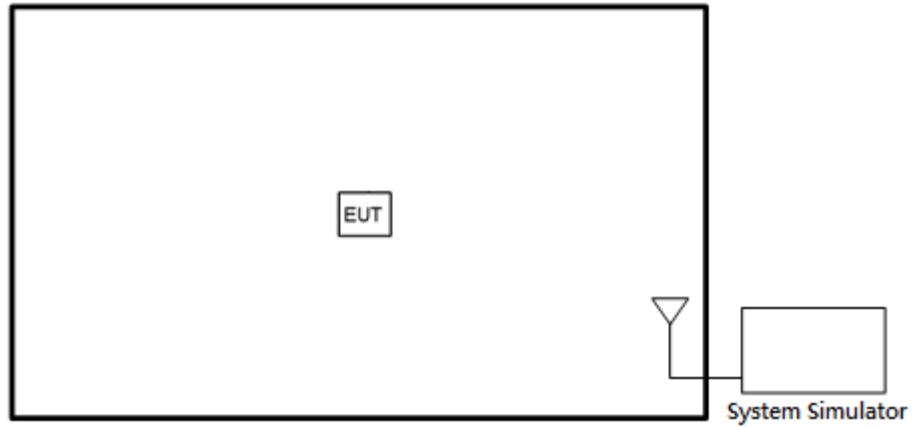

<EUT with Adapter>

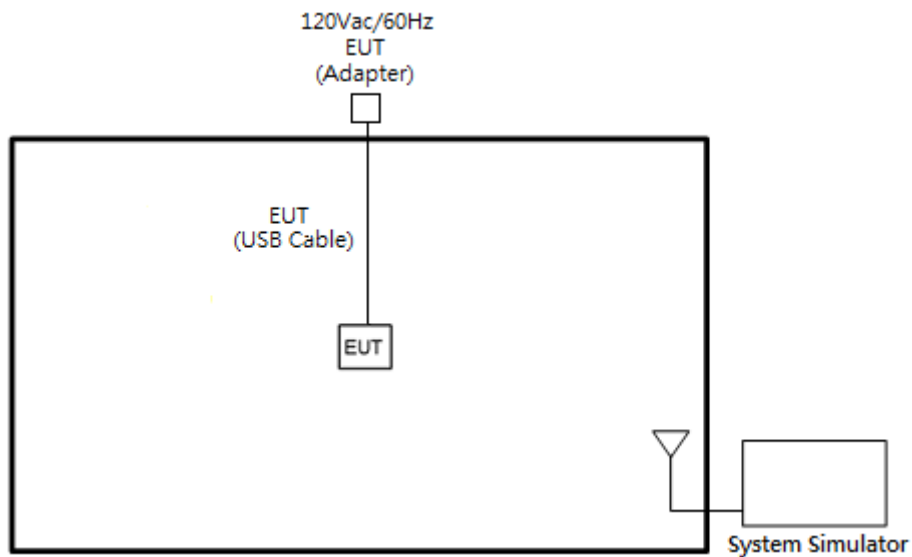

<EUT with Earphone>

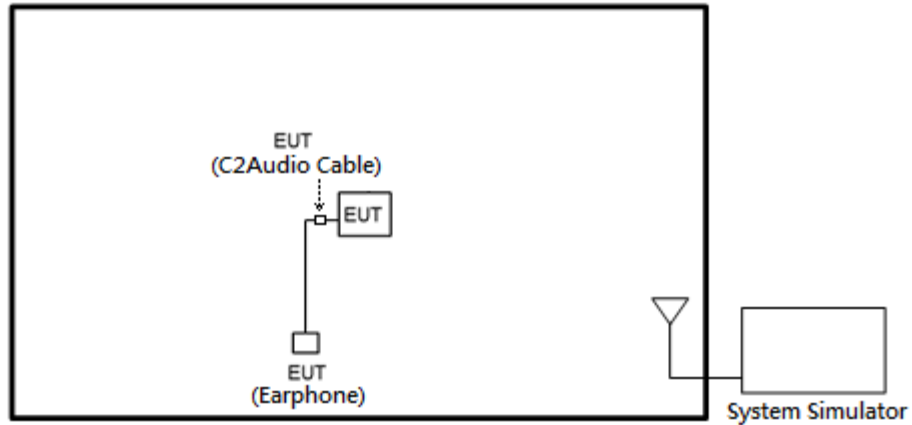

2.3 Support Unit used in test configuration and system

Item	Equipment	Trade Name	Model No.	FCC ID	Data Cable	Power Cord
1.	LTE Base Station	Anritsu	MT8820C	N/A	N/A	Unshielded, 1.8 m



### 2.4 Frequency List of Low/Middle/High Channels

LTE Band 5 Channel and Frequency List				
BW [MHz]	Channel/Frequency(MHz)	Lowest	Middle	Highest
10	Channel	20450	20525	20600
	Frequency	829	836.5	844
5	Channel	20425	20525	20625
	Frequency	826.5	836.5	846.5
3	Channel	20415	20525	20635
	Frequency	825.5	836.5	847.5
1.4	Channel	20407	20525	20643
	Frequency	824.7	836.5	848.3

LTE Band 7 Channel and Frequency List				
BW [MHz]	Channel/Frequency(MHz)	Lowest	Middle	Highest
20	Channel	20850	21100	21350
	Frequency	2510	2535	2560
15	Channel	20825	21100	21375
	Frequency	2507.5	2535	2562.5
10	Channel	20800	21100	21400
	Frequency	2505	2535	2565
5	Channel	20775	21100	21425
	Frequency	2502.5	2535	2567.5

### 3 Conducted Test Items

#### 3.1 Measuring Instruments

See list of measuring instruments of this test report.

#### 3.2 Test Setup

##### 3.2.1 Conducted Output Power

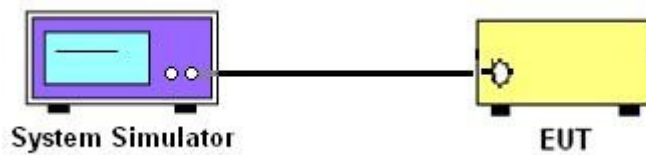

##### 3.2.2 Peak-to-Average Ratio, Occupied Bandwidth ,Conducted Band-Edge and Conducted Spurious Emission

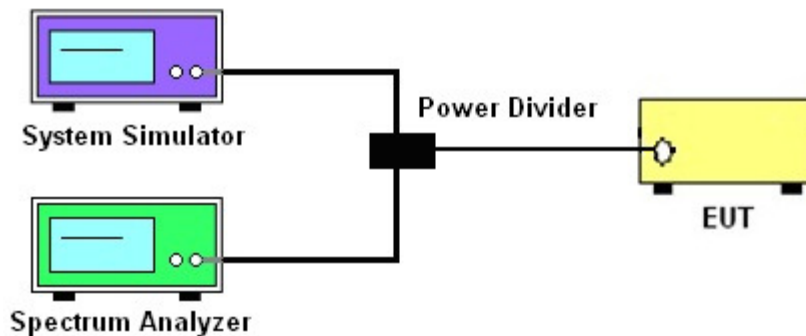

##### 3.2.3 Frequency Stability

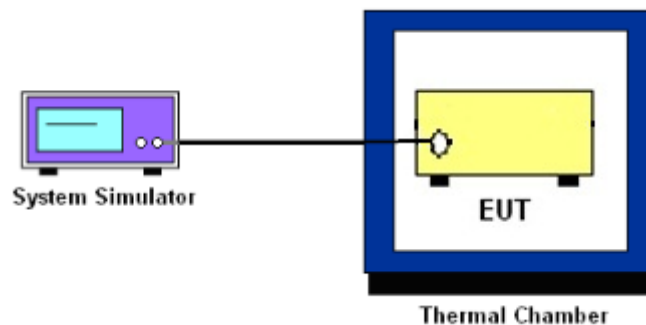

### 3.3 Test Result of Conducted Test

Please refer to Appendix A.



### 3.4 Conducted Output Power and ERP/EIRP

#### 3.4.1 Description of the Conducted Output Power Measurement and ERP/EIRP Measurement

A system simulator was used to establish communication with the EUT. Its parameters were set to force the EUT transmitting at maximum output power. The measured power in the radio frequency on the transmitter output terminals shall be reported.

The ERP of mobile transmitters must not exceed 7 Watts for LTE Band 5.

The EIRP of mobile transmitters must not exceed 2 Watts for LTE Band 7.

According to KDB 412172 D01 Power Approach,

$EIRP = P_T + G_T - L_C$ ,  $ERP = EIRP - 2.15$ , where

$P_T$  = transmitter output power in dBm

$G_T$  = gain of the transmitting antenna in dBi

$L_C$  = signal attenuation in the connecting cable between the transmitter and antenna in dB

#### 3.4.2 Test Procedures

1. The transmitter output port was connected to the system simulator.
2. Set EUT at maximum power through the system simulator.
3. Select lowest, middle, and highest channels for each band and different modulation.
4. Measure and record the power level from the system simulator.



### 3.5 Frequency Stability

#### 3.5.1 Description of Frequency Stability Measurement

The frequency stability shall be measured by variation of ambient temperature and variation of primary supply voltage to ensure that the fundamental emission stays within the authorized frequency block. The frequency stability of the transmitter shall be maintained within  $\pm 0.00025\%$  ( $\pm 2.5\text{ppm}$ ) of the center frequency.

#### 3.5.2 Test Procedures for Temperature Variation

The testing follows FCC KDB 971168 v03 Section 9.0.

1. The EUT was set up in the thermal chamber and connected with the system simulator.
2. With power OFF, the temperature was decreased to  $-30^{\circ}\text{C}$  and the EUT was stabilized before testing. Power was applied and the maximum change in frequency was recorded within one minute.
3. With power OFF, the temperature was raised in  $10^{\circ}\text{C}$  step up to  $50^{\circ}\text{C}$ . The EUT was stabilized at each step for at least half an hour. Power was applied and the maximum frequency change was recorded within one minute.

#### 3.5.3 Test Procedures for Voltage Variation

The testing follows FCC KDB 971168 v03 Section 9.0.

1. The EUT was placed in a temperature chamber at  $20\pm 5^{\circ}\text{C}$  and connected with the system simulator.
2. The power supply voltage to the EUT was varied from 85% to 115% of the nominal value measured at the input to the EUT.
3. The variation in frequency was measured for the worst case.



## 4 Radiated Test Items

### 4.1 Measuring Instruments

See list of measuring instruments of this test report.

### 4.2 Test Setup

#### 4.2.1 For radiated test from 30MHz to 1GHz

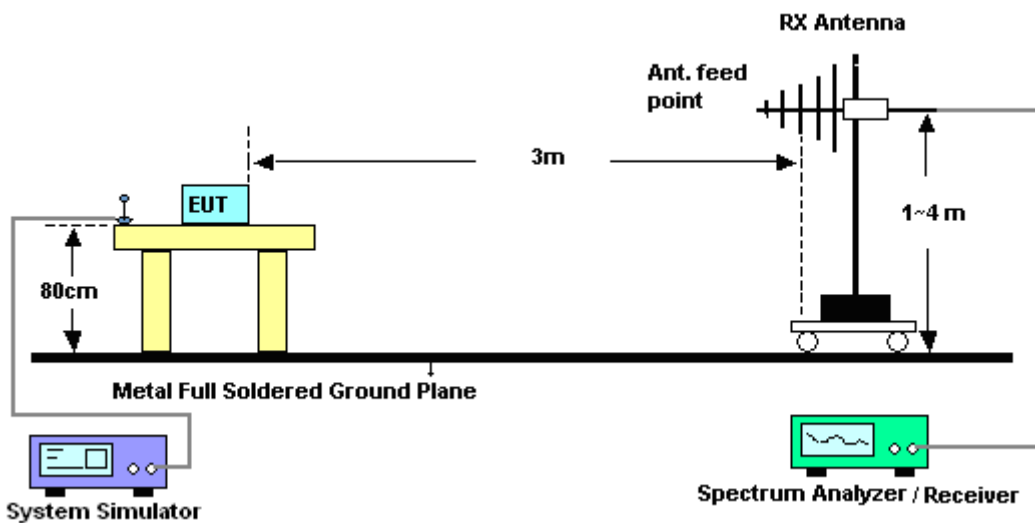

#### 4.2.2 For radiated test above 1GHz

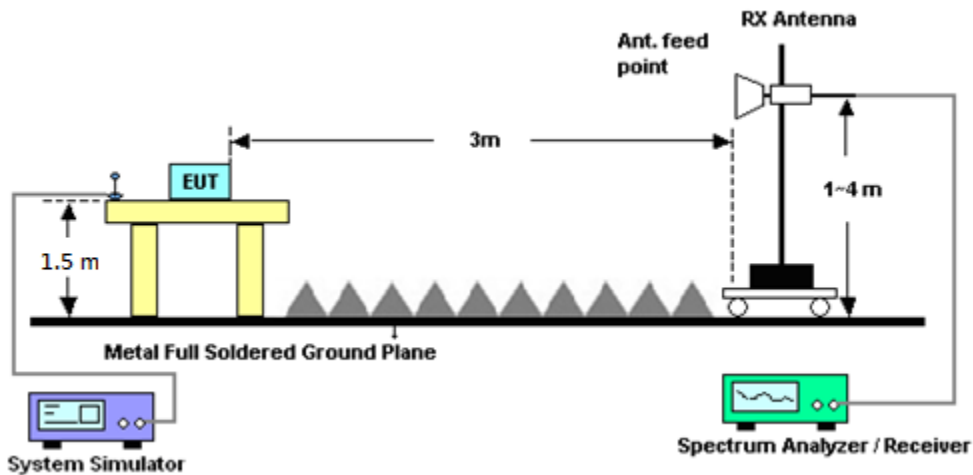

### 4.3 Test Result of Radiated Test

Please refer to Appendix B.



## **4.4 Radiated Spurious Emission**

### **4.4.1 Description of Radiated Spurious Emission**

The radiated spurious emission was measured by substitution method according to ANSI / TIA-603-E. The power of any emission outside of the authorized operating frequency ranges must be attenuated below the transmitter power (P) by a factor of at least  $43 + 10 \log (P)$  dB. The spectrum is scanned from 30 MHz up to a frequency including its 10th harmonic.

### **4.4.2 Test Procedures**

The testing follows FCC KDB 971168 v03 Section 5.8 and ANSI / TIA-603-E Section 2.2.12.

1. The EUT was placed on a turntable with 0.8 meter for frequency below 1GHz and 1.5 meter for frequency above 1GHz respectively above ground.
2. The EUT was set 3 meters from the receiving antenna, which was mounted on the antenna tower.
3. The table was rotated 360 degrees to determine the position of the highest spurious emission.
4. The height of the receiving antenna is varied between one meter and four meters to search the maximum spurious emission for both horizontal and vertical polarizations.
5. Make the measurement with the spectrum analyzer's RBW = 1MHz, VBW = 3MHz, taking the record of maximum spurious emission.
6. A horn antenna was substituted in place of the EUT and was driven by a signal generator.
7. Tune the output power of signal generator to the same emission level with EUT maximum spurious emission.
8. Taking the record of output power at antenna port.
9. Repeat step 7 to step 8 for another polarization.
10. The RF fundamental frequency should be excluded against the limit line in the operating frequency band.

The limit line is derived from  $43 + 10\log(P)$ dB below the transmitter power P(Watts)



## 5 List of Measuring Equipment

Instrument	Manufacturer	Model No.	Serial No.	Characteristics	Calibration Date	Test Date	Due Date	Remark
LTE Base Station	Anritsu	MT8820C	620143282 1	GSM/GPRS /WCDMA/LTE	Oct. 13, 2017	Feb. 19, 2018 ~ Feb. 28, 2018	Oct. 12, 2018	Conducted (TH05-HY)
Spectrum Analyzer	Rohde & Schwarz	FSV40	101397	10Hz~40GHz	Nov. 09, 2017	Feb. 19, 2018 ~ Feb. 28, 2018	Nov. 08, 2018	Conducted (TH05-HY)
Temperature Chamber	ESPEC	SH-641	92013720	-30°C~70°C	Aug. 28, 2017	Feb. 19, 2018 ~ Feb. 28, 2018	Aug. 27, 2018	Conducted (TH05-HY)
Programmable Power Supply	GW Instek	PSS-2005	EL890001	1V~20V 0.5A~5A	Oct. 06, 2017	Feb. 19, 2018 ~ Feb. 28, 2018	Oct. 05, 2018	Conducted (TH05-HY)
Amplifier	MITEQ	TTA1840-35- HG	1871923	18GHz~40GHz, VSWR : 2.5:1 max	Jul. 18, 2017	Mar. 06, 2018 ~ Mar. 08, 2018	Jul. 17, 2018	Radiation (03CH13-HY)
Amplifier	Sonoma-Instrument	310 N	187282	9KHz~1GHz	Dec. 21, 2016	Mar. 06, 2018 ~ Mar. 08, 2018	Dec. 20, 2018	Radiation (03CH13-HY)
Bilog Antenna	TESEQ	CBL 6111D&00800 N1D01N-06	40103&07	30MHz to 1GHz	Jan. 10, 2018	Mar. 06, 2018 ~ Mar. 08, 2018	Jan. 09, 2019	Radiation (03CH13-HY)
Horn Antenna	SCHWARZBE CK	BBHA 9120 D	9120D-124 1	1GHz ~ 18GHz	Jun. 15, 2017	Mar. 06, 2018 ~ Mar. 08, 2018	Jun. 14, 2018	Radiation (03CH13-HY)
Preamplifier	MITEQ	AMF-7D-0010 1800-30-10P	1590074	1GHz~18GHz	May 22, 2017	Mar. 06, 2018 ~ Mar. 08, 2018	May 21, 2018	Radiation (03CH13-HY)
Preamplifier	Keysight	83017A	MY532701 47	1GHz~26.5GHz	Feb. 02, 2018	Mar. 06, 2018 ~ Mar. 08, 2018	Feb. 01, 2019	Radiation (03CH13-HY)
Spectrum Analyzer	Keysight	N9010A	MY553705 26	10Hz~44GHz	Mar. 15, 2017	Mar. 06, 2018 ~ Mar. 08, 2018	Mar. 14, 2018	Radiation (03CH13-HY)
Controller	EMEC	EM1000	N/A	Control Turn table & Ant Mast	N/A	Mar. 06, 2018 ~ Mar. 08, 2018	N/A	Radiation (03CH13-HY)
Antenna Mast	EMEC	AM-BS-4500- B	N/A	1m~4m	N/A	Mar. 06, 2018 ~ Mar. 08, 2018	N/A	Radiation (03CH13-HY)
Turn Table	EMEC	TT2000	N/A	0~360 Degree	N/A	Mar. 06, 2018 ~ Mar. 08, 2018	N/A	Radiation (03CH13-HY)
SHF-EHF Horn Antenna	SCHWARZBE CK	BBHA 9170	BBHA9170 251	18GHz- 40GHz	Nov. 10, 2017	Mar. 06, 2018 ~ Mar. 08, 2018	Nov. 09, 2018	Radiation (03CH13-HY)
SHF-EHF Horn Antenna	SCHWARZBE CK	BBHA 9170	BBHA9170 584	18GHz- 40GHz	Nov. 27, 2017	Mar. 06, 2018 ~ Mar. 08, 2018	Nov. 26, 2018	Radiation (03CH13-HY)
Horn Antenna	SCHWARZBE CK	BBHA 9120 D	9120D-152 2	1G~18GHz	Mar. 17, 2017	Mar. 06, 2018 ~ Mar. 08, 2018	Mar. 16, 2018	Radiation (03CH13-HY)
Signal Generator	Rohde & Schwarz	SMF100A	101107	100kHz~40GHz	May 22, 2017	Mar. 06, 2018 ~ Mar. 08, 2018	May 21, 2018	Radiation (03CH13-HY)



## 6 Uncertainty of Evaluation

### Uncertainty of Radiated Emission Measurement (30 MHz ~ 1000 MHz)

Measuring Uncertainty for a Level of Confidence of 95% ( $U = 2Uc(y)$ )	3.07
---	------

### Uncertainty of Radiated Emission Measurement (1 GHz ~ 18 GHz)

Measuring Uncertainty for a Level of Confidence of 95% ( $U = 2Uc(y)$ )	3.48
---	------

### Uncertainty of Radiated Emission Measurement (18 GHz ~ 40 GHz)

Measuring Uncertainty for a Level of Confidence of 95% ( $U = 2Uc(y)$ )	3.92
---	------



## Appendix A. Test Results of Conducted Test

### Conducted Output Power(Average power)

LTE Band 5 Maximum Average Power [dBm]						
BW [MHz]	RB Size	RB Offset	Mod	Lowest	Middle	Highest
10	1	0	QPSK	22.90	22.94	22.85
10	1	25		22.74	22.79	22.82
10	1	49		22.76	22.67	22.72
10	25	0		21.92	21.95	21.90
10	25	12		21.92	21.81	21.87
10	25	25		21.85	21.77	21.82
10	50	0		21.89	21.90	21.74
10	1	0	16-QAM	22.17	22.18	22.08
10	1	25		22.10	22.13	22.17
10	1	49		22.13	22.03	22.09
10	25	0		20.91	20.92	20.88
10	25	12		20.98	20.92	20.99
10	25	25		20.95	20.85	20.91
10	50	0		21.00	20.94	20.84
10	1	0	64-QAM	21.05	21.10	21.00
10	1	25		21.04	21.06	21.07
10	1	49		21.04	20.99	21.01
10	25	0		19.93	19.94	19.88
10	25	12		20.04	19.94	19.98
10	25	25		19.93	19.88	19.93
10	50	0		19.80	19.70	19.67
5	1	0	QPSK	22.61	22.64	22.62
5	1	12		22.59	22.57	22.57
5	1	24		22.55	22.56	22.56
5	12	0		21.62	21.65	21.63
5	12	7		21.66	21.63	21.65
5	12	13		21.60	21.60	21.59
5	25	0		21.60	21.63	21.59
5	1	0	16-QAM	21.97	21.98	21.96
5	1	12		21.96	21.93	21.94
5	1	24		21.89	21.88	21.89
5	12	0		20.74	20.75	20.70
5	12	7		20.74	20.71	20.76
5	12	13		20.72	20.70	20.71
5	25	0		20.72	20.70	20.70



LTE Band 5 Maximum Average Power [dBm]						
BW [MHz]	RB Size	RB Offset	Mod	Lowest	Middle	Highest
5	1	0	64-QAM	20.92	20.91	20.91
5	1	12		20.86	20.85	20.88
5	1	24		20.83	20.82	20.81
5	12	0		19.78	19.78	19.78
5	12	7		19.79	19.76	19.78
5	12	13		19.74	19.74	19.73
5	25	0		19.72	19.69	19.71
3	1	0	QPSK	22.67	22.66	22.67
3	1	8		22.67	22.61	22.63
3	1	14		22.68	22.61	22.64
3	8	0		21.72	21.65	21.69
3	8	4		21.73	21.66	21.63
3	8	7		21.61	21.66	21.67
3	15	0		21.70	21.64	21.66
3	1	0	16-QAM	21.98	21.99	22.01
3	1	8		22.04	21.95	21.99
3	1	14		22.01	21.91	21.99
3	8	0		20.77	20.80	20.83
3	8	4		20.87	20.81	20.84
3	8	7		20.82	20.77	20.82
3	15	0		20.81	20.75	20.78
3	1	0	64-QAM	21.96	21.88	21.89
3	1	8		21.94	21.86	21.88
3	1	14		21.92	21.81	21.90
3	8	0		20.80	20.67	20.78
3	8	4		20.82	20.76	20.81
3	8	7		20.77	20.73	20.78
3	15	0		20.78	20.74	20.76



LTE Band 5 Maximum Average Power [dBm]						
BW [MHz]	RB Size	RB Offset	Mod	Lowest	Middle	Highest
1.4	1	0	QPSK	22.79	22.74	22.73
1.4	1	3		22.87	22.80	22.82
1.4	1	5		22.78	22.71	22.75
1.4	3	0		22.84	22.76	22.80
1.4	3	1		22.87	22.79	22.82
1.4	3	3		22.83	22.76	22.80
1.4	6	0		21.83	21.78	21.78
1.4	1	0	16-QAM	22.16	22.10	22.10
1.4	1	3		22.21	22.16	22.17
1.4	1	5		22.13	22.07	22.09
1.4	3	0		21.97	21.88	21.89
1.4	3	1		21.97	21.89	21.95
1.4	3	3		21.93	21.87	21.89
1.4	6	0		20.98	20.94	20.94
1.4	1	0	64-QAM	21.08	21.04	21.03
1.4	1	3		21.13	21.07	21.09
1.4	1	5		21.05	20.98	21.02
1.4	3	0		21.08	20.98	21.01
1.4	3	1		21.12	21.04	21.06
1.4	3	3		21.05	21.00	21.00
1.4	6	0		19.93	19.87	19.89



LTE Band 7 Maximum Average Power [dBm]						
BW [MHz]	RB Size	RB Offset	Mod	Lowest	Middle	Highest
20	1	0	QPSK	22.23	22.24	22.22
20	1	49		22.18	22.18	22.04
20	1	99		22.17	22.10	22.01
20	50	0		21.20	21.21	21.18
20	50	24		21.13	21.11	21.05
20	50	50		21.15	21.08	21.13
20	100	0		21.07	21.15	21.03
20	1	0	16-QAM	21.34	21.33	21.17
20	1	49		21.49	21.46	21.32
20	1	99		21.47	21.44	21.35
20	50	0		20.17	20.18	20.12
20	50	24		20.23	20.28	20.16
20	50	50		20.26	20.34	20.22
20	100	0		20.16	20.24	20.10
20	1	0	64-QAM	20.25	20.26	20.04
20	1	49		20.42	20.43	20.25
20	1	99		20.39	20.36	20.24
20	50	0		19.20	19.17	19.13
20	50	24		19.21	19.29	19.17
20	50	50		19.26	19.34	19.23
20	100	0		19.17	19.23	19.12
15	1	0	QPSK	22.13	22.13	22.03
15	1	37		22.22	22.22	22.06
15	1	74		22.15	22.11	22.01
15	36	0		21.13	21.10	21.03
15	36	20		21.25	21.24	21.09
15	36	39		21.15	21.23	21.09
15	75	0		21.19	21.20	21.02
15	1	0	16-QAM	21.43	21.44	21.22
15	1	37		21.52	21.53	21.29
15	1	74		21.46	21.42	21.30
15	36	0		20.23	20.19	20.08
15	36	20		20.35	20.34	20.14
15	36	39		20.26	20.36	20.16
15	75	0		20.25	20.29	20.08
15	1	0	64-QAM	20.34	20.34	20.13
15	1	37		20.45	20.44	20.22
15	1	74		20.36	20.33	20.19
15	36	0		19.24	19.23	19.10
15	36	20		19.36	19.36	19.16
15	36	39		19.26	19.38	19.20
15	75	0		19.30	19.28	19.08





LTE Band 7 Maximum Average Power [dBm]						
BW [MHz]	RB Size	RB Offset	Mod	Lowest	Middle	Highest
10	1	0	QPSK	22.12	22.16	22.04
10	1	25		22.16	22.20	22.04
10	1	49		22.18	22.05	22.02
10	25	0		21.13	21.15	21.05
10	25	12		21.18	21.21	21.07
10	25	25		21.17	21.25	21.07
10	50	0		21.16	21.18	21.01
10	1	0	16-QAM	21.45	21.48	21.16
10	1	25		21.49	21.52	21.22
10	1	49		21.52	21.37	21.35
10	25	0		20.18	20.21	20.12
10	25	12		20.29	20.28	20.20
10	25	25		20.29	20.29	20.17
10	50	0		20.26	20.27	20.20
10	1	0	64-QAM	20.34	20.36	20.21
10	1	25		20.40	20.44	20.20
10	1	49		20.40	20.29	20.24
10	25	0		19.19	19.22	19.15
10	25	12		19.29	19.29	19.23
10	25	25		19.29	19.32	19.18
10	50	0		19.25	19.26	19.20
5	1	0	QPSK	22.14	22.15	22.10
5	1	12		22.21	22.19	22.08
5	1	24		22.13	22.10	22.06
5	12	0		21.20	21.15	21.04
5	12	7		21.25	21.24	21.00
5	12	13		21.19	21.23	21.03
5	25	0		21.15	21.20	21.00
5	1	0	16-QAM	21.46	21.43	21.16
5	1	12		21.54	21.53	21.26
5	1	24		21.45	21.53	21.27
5	12	0		20.30	20.25	20.04
5	12	7		20.34	20.33	20.07
5	12	13		20.25	20.31	20.07
5	25	0		20.24	20.27	20.06
5	1	0	64-QAM	20.36	20.33	20.10
5	1	12		20.45	20.41	20.14
5	1	24		20.38	20.46	20.21
5	12	0		19.35	19.28	19.05
5	12	7		19.41	19.34	19.14
5	12	13		19.31	19.35	19.23
5	25	0		19.25	19.26	19.18



## Appendix B. Test Results of ERP/EIRP and Radiated Test

### ERP/EIRP

<For Main Antenna>

LTE Band 5 / 1.4MHz (Average) (GT - LC = -5.6 dB)							
Channel	Mode	RB		Conducted		ERP	
		Size	Offset	Power (dBm)	Power (Watts)	ERP(dBm)	ERP(W)
Lowest	QPSK	1	3	22.87	0.1936	15.12	0.0325
Middle		1	3	22.80	0.1905	15.05	0.0320
Highest		1	3	22.82	0.1914	15.07	0.0321
Lowest	16QAM	1	3	22.21	0.1663	14.46	0.0279
Middle		1	3	22.16	0.1644	14.41	0.0276
Highest		1	3	22.17	0.1648	14.42	0.0277
Lowest	64QAM	1	3	21.13	0.1297	13.38	0.0218
Middle		1	3	21.07	0.1279	13.32	0.0215
Highest		1	3	21.09	0.1285	13.34	0.0216
Limit	ERP < 7W			Result		PASS	

LTE Band 5 / 3MHz (Average) (GT - LC = -5.6 dB)							
Channel	Mode	RB		Conducted		ERP	
		Size	Offset	Power (dBm)	Power (Watts)	ERP(dBm)	ERP(W)
Lowest	QPSK	1	14	22.68	0.1854	14.93	0.0311
Middle		1	14	22.61	0.1824	14.86	0.0306
Highest		1	14	22.64	0.1837	14.89	0.0308
Lowest	16QAM	1	8	22.04	0.1600	14.29	0.0269
Middle		1	8	21.95	0.1567	14.20	0.0263
Highest		1	8	21.99	0.1581	14.24	0.0265
Lowest	64QAM	1	0	21.96	0.1570	14.21	0.0264
Middle		1	0	21.88	0.1542	14.13	0.0259
Highest		1	0	21.89	0.1545	14.14	0.0259
Limit	ERP < 7W			Result		PASS	



LTE Band 5 / 5MHz (Average) (GT - LC = -5.6 dB)							
Channel	Mode	RB		Conducted		ERP	
		Size	Offset	Power (dBm)	Power (Watts)	ERP(dBm)	ERP(W)
Lowest	QPSK	1	0	22.61	0.1824	14.86	0.0306
Middle		1	0	22.64	0.1837	14.89	0.0308
Highest		1	0	22.62	0.1828	14.87	0.0307
Lowest	16QAM	1	0	21.97	0.1574	14.22	0.0264
Middle		1	0	21.98	0.1578	14.23	0.0265
Highest		1	0	21.96	0.1570	14.21	0.0264
Lowest	64QAM	1	0	20.92	0.1236	13.17	0.0207
Middle		1	0	20.91	0.1233	13.16	0.0207
Highest		1	0	20.91	0.1233	13.16	0.0207
Limit	ERP < 7W			Result		PASS	

LTE Band 5 / 10MHz (Average) (GT - LC = -5.6 dB)							
Channel	Mode	RB		Conducted		ERP	
		Size	Offset	Power (dBm)	Power (Watts)	ERP(dBm)	ERP(W)
Lowest	QPSK	1	0	22.90	0.1950	15.15	0.0327
Middle		1	0	22.94	0.1968	15.19	0.0330
Highest		1	0	22.85	0.1928	15.10	0.0324
Lowest	16QAM	1	0	22.17	0.1648	14.42	0.0277
Middle		1	0	22.18	0.1652	14.43	0.0277
Highest		1	0	22.08	0.1614	14.33	0.0271
Lowest	64QAM	1	0	21.05	0.1274	13.30	0.0214
Middle		1	0	21.10	0.1288	13.35	0.0216
Highest		1	0	21.00	0.1259	13.25	0.0211
Limit	ERP < 7W			Result		PASS	



LTE Band 7 / 5MHz (Average) (GT - LC = 0.3 dB)							
Channel	Mode	RB		Conducted		EIRP	
		Size	Offset	Power (dBm)	Power (Watts)	EIRP(dBm)	EIRP(W)
Lowest	QPSK	1	12	22.21	0.1663	22.51	0.1782
Middle		1	12	22.19	0.1656	22.49	0.1774
Highest		1	12	22.08	0.1614	22.38	0.1730
Lowest	16QAM	1	12	21.54	0.1426	21.84	0.1528
Middle		1	12	21.53	0.1422	21.83	0.1524
Highest		1	12	21.26	0.1337	21.56	0.1432
Lowest	64QAM	1	24	20.38	0.1091	20.68	0.1169
Middle		1	24	20.46	0.1112	20.76	0.1191
Highest		1	24	20.21	0.1050	20.51	0.1125
Limit	EIRP < 2W			Result		PASS	

LTE Band 7 / 10MHz (Average) (GT - LC = 0.3 dB)							
Channel	Mode	RB		Conducted		EIRP	
		Size	Offset	Power (dBm)	Power (Watts)	EIRP(dBm)	EIRP(W)
Lowest	QPSK	1	25	22.16	0.1644	22.46	0.1762
Middle		1	25	22.20	0.1660	22.50	0.1778
Highest		1	25	22.04	0.1600	22.34	0.1714
Lowest	16QAM	1	25	21.49	0.1409	21.79	0.1510
Middle		1	25	21.52	0.1419	21.82	0.1521
Highest		1	25	21.22	0.1324	21.52	0.1419
Lowest	64QAM	1	25	20.40	0.1096	20.70	0.1175
Middle		1	25	20.44	0.1107	20.74	0.1186
Highest		1	25	20.20	0.1047	20.50	0.1122
Limit	EIRP < 2W			Result		PASS	

LTE Band 7 / 15MHz (Average) (GT - LC = 0.3 dB)							
Channel	Mode	RB		Conducted		EIRP	
		Size	Offset	Power (dBm)	Power (Watts)	EIRP(dBm)	EIRP(W)
Lowest	QPSK	1	37	22.22	0.1667	22.52	0.1786
Middle		1	37	22.22	0.1667	22.52	0.1786
Highest		1	37	22.06	0.1607	22.36	0.1722
Lowest	16QAM	1	37	21.52	0.1419	21.82	0.1521
Middle		1	37	21.53	0.1422	21.83	0.1524
Highest		1	37	21.29	0.1346	21.59	0.1442
Lowest	64QAM	1	37	20.45	0.1109	20.75	0.1189
Middle		1	37	20.44	0.1107	20.74	0.1186
Highest		1	37	20.22	0.1052	20.52	0.1127
Limit	EIRP < 2W			Result		PASS	



LTE Band 7 / 20MHz (Average) (GT - LC = 0.3 dB)							
Channel	Mode	RB		Conducted		EIRP	
		Size	Offset	Power (dBm)	Power (Watts)	EIRP(dBm)	EIRP(W)
Lowest	QPSK	1	0	22.23	0.1671	22.53	0.1791
Middle		1	0	22.24	0.1675	22.54	0.1795
Highest		1	0	22.22	0.1667	22.52	0.1786
Lowest	16QAM	1	49	21.49	0.1409	21.79	0.1510
Middle		1	49	21.46	0.1400	21.76	0.1500
Highest		1	49	21.32	0.1355	21.62	0.1452
Lowest	64QAM	1	49	20.42	0.1102	20.72	0.1180
Middle		1	49	20.43	0.1104	20.73	0.1183
Highest		1	49	20.25	0.1059	20.55	0.1135
Limit	EIRP < 2W			Result		PASS	



<For Aux. Antenna>

LTE Band 7 / 5MHz (Average) (GT - LC = -4.7 dB)							
Channel	Mode	RB		Conducted		EIRP	
		Size	Offset	Power (dBm)	Power (Watts)	EIRP(dBm)	EIRP(W)
Lowest	QPSK	1	12	22.21	0.1663	17.51	0.0564
Middle		1	12	22.19	0.1656	17.49	0.0561
Highest		1	12	22.08	0.1614	17.38	0.0547
Lowest	16QAM	1	12	21.54	0.1426	16.84	0.0483
Middle		1	12	21.53	0.1422	16.83	0.0482
Highest		1	12	21.26	0.1337	16.56	0.0453
Lowest	64QAM	1	24	20.38	0.1091	15.68	0.0370
Middle		1	24	20.46	0.1112	15.76	0.0377
Highest		1	24	20.21	0.1050	15.51	0.0356
Limit	EIRP < 2W			Result		PASS	

LTE Band 7 / 10MHz (Average) (GT - LC = -4.7 dB)							
Channel	Mode	RB		Conducted		EIRP	
		Size	Offset	Power (dBm)	Power (Watts)	EIRP(dBm)	EIRP(W)
Lowest	QPSK	1	25	22.16	0.1644	17.46	0.0557
Middle		1	25	22.20	0.1660	17.50	0.0562
Highest		1	25	22.04	0.1600	17.34	0.0542
Lowest	16QAM	1	25	21.49	0.1409	16.79	0.0478
Middle		1	25	21.52	0.1419	16.82	0.0481
Highest		1	25	21.22	0.1324	16.52	0.0449
Lowest	64QAM	1	25	20.40	0.1096	15.70	0.0372
Middle		1	25	20.44	0.1107	15.74	0.0375
Highest		1	25	20.20	0.1047	15.50	0.0355
Limit	EIRP < 2W			Result		PASS	

LTE Band 7 / 15MHz (Average) (GT - LC = -4.7 dB)							
Channel	Mode	RB		Conducted		EIRP	
		Size	Offset	Power (dBm)	Power (Watts)	EIRP(dBm)	EIRP(W)
Lowest	QPSK	1	37	22.22	0.1667	17.52	0.0565
Middle		1	37	22.22	0.1667	17.52	0.0565
Highest		1	37	22.06	0.1607	17.36	0.0545
Lowest	16QAM	1	37	21.52	0.1419	16.82	0.0481
Middle		1	37	21.53	0.1422	16.83	0.0482
Highest		1	37	21.29	0.1346	16.59	0.0456
Lowest	64QAM	1	37	20.45	0.1109	15.75	0.0376
Middle		1	37	20.44	0.1107	15.74	0.0375
Highest		1	37	20.22	0.1052	15.52	0.0356
Limit	EIRP < 2W			Result		PASS	



LTE Band 7 / 20MHz (Average) (GT - LC = -4.7 dB)							
Channel	Mode	RB		Conducted		EIRP	
		Size	Offset	Power (dBm)	Power (Watts)	EIRP(dBm)	EIRP(W)
Lowest	QPSK	1	0	22.23	0.1671	17.53	0.0566
Middle		1	0	22.24	0.1675	17.54	0.0568
Highest		1	0	22.22	0.1667	17.52	0.0565
Lowest	16QAM	1	49	21.49	0.1409	16.79	0.0478
Middle		1	49	21.46	0.1400	16.76	0.0474
Highest		1	49	21.32	0.1355	16.62	0.0459
Lowest	64QAM	1	49	20.42	0.1102	15.72	0.0373
Middle		1	49	20.43	0.1104	15.73	0.0374
Highest		1	49	20.25	0.1059	15.55	0.0359
Limit	EIRP < 2W			Result		PASS	



**Radiated Spurious Emission**

**Part22H LTE Band 5**

<For Main Antenna>

LTE Band 5 / 10MHz / QPSK									
Channel	Frequency ( MHz )	ERP ( dBm )	Limit ( dBm )	Over Limit ( dB )	SPA Reading (dBm)	S.G. Power ( dBm )	TX Cable loss ( dB )	TX Antenna Gain (dBi)	Polarization (H/V)
Lowest	1648	-53.03	-13	-40.03	-67.64	-58.42	1.23	8.76	H
	2472	-43.44	-13	-30.44	-61.16	-50.33	1.44	10.48	H
	3296	-54.28	-13	-41.28	-76.31	-62.22	1.70	11.79	H
									H
									H
									H
	1648	-54.26	-13	-41.26	-68.87	-59.65	1.23	8.76	V
	2472	-43.22	-13	-30.22	-60.94	-50.11	1.44	10.48	V
	3296	-55.09	-13	-42.09	-76.12	-63.03	1.70	11.79	V
									V
									V
									V
Middle	1664	-56.27	-13	-43.27	-70.93	-61.71	1.23	8.82	H
	2496	-53.41	-13	-40.41	-71.22	-60.32	1.44	10.50	H
	3328	-55.13	-13	-42.13	-76.25	-63.14	1.73	11.88	H
									H
									H
									H
	1664	-54.83	-13	-41.83	-69.49	-60.27	1.23	8.82	V
	2496	-48.84	-13	-35.84	-66.65	-55.75	1.44	10.50	V
	3328	-54.89	-13	-41.89	-76.01	-62.90	1.73	11.88	V
									V
									V
									V





Highest	1680	-53.14	-13	-40.14	-67.85	-58.64	1.24	8.88	H
	2520	-43.64	-13	-30.64	-61.53	-50.57	1.44	10.52	H
	3360	-54.69	-13	-41.69	-75.9	-62.76	1.76	11.98	H
									H
									H
									H
									H
	1680	-52.45	-13	-39.45	-67.16	-57.95	1.24	8.88	V
	2520	-40.37	-13	-27.37	-58.26	-47.30	1.44	10.52	V
	3360	-54.75	-13	-41.75	-75.96	-62.82	1.76	11.98	V
									V
									V
									V
									V

Remark: Spurious emissions within 30-1000MHz were found more than 20dB below limit line.

**Part27M LTE Band 7**



LTE Band 7 / 20MHz / QPSK									
Channel	Frequency ( MHz )	EIRP ( dBm )	Limit ( dBm )	Over Limit ( dB )	SPA Reading (dBm)	S.G. Power ( dBm )	TX Cable loss ( dB )	TX Antenna Gain (dBi)	Polarization (H/V)
Lowest	5040	-42.12	-25	-17.12	-41.44	-51.88	2.34	12.11	H
	7560	-44.36	-25	-19.36	-52.47	-52.46	2.11	10.22	H
	10080	-43.43	-25	-18.43	-58.04	-53.34	1.93	11.83	H
	12600	-36.50	-25	-11.50	-53.35	-47.14	2.54	13.18	H
									H
									H
									H
	5040	-41.04	-25	-16.04	-40.36	-50.80	2.34	12.11	V
	7560	-46.06	-25	-21.06	-54.17	-54.16	2.11	10.22	V
	10080	-42.38	-25	-17.38	-56.99	-52.29	1.93	11.83	V
	12600	-37.23	-25	-12.23	-54.08	-47.87	2.54	13.18	V
									V
									V
									V
Middle	5088	-39.65	-25	-14.65	-39.13	-49.44	2.32	12.12	H
	7632	-43.33	-25	-18.33	-51.59	-51.69	2.11	10.48	H
	10176	-37.11	-25	-12.11	-52.13	-46.90	2.08	11.87	H
	12720	-34.35	-25	-9.35	-51.93	-44.85	2.53	13.04	H
									H
									H
									H
	5088	-46.48	-25	-21.48	-45.96	-56.27	2.32	12.12	V
	7632	-46.81	-25	-21.81	-55.07	-55.17	2.11	10.48	V
	10176	-41.57	-25	-16.57	-56.59	-51.36	2.08	11.87	V
	12720	-37.08	-25	-12.08	-54.66	-47.58	2.53	13.04	V
									V
									V
									V



Highest	5136	-35.53	-25	-10.53	-35.26	-45.35	2.30	12.13	H
	7704	-49.06	-25	-24.06	-57.47	-57.68	2.11	10.73	H
	10272	-39.35	-25	-14.35	-54.7	-49.03	2.23	11.91	H
	12840	-34.94	-25	-9.94	-53.26	-45.31	2.52	12.89	H
									H
									H
									H
	5136	-47.08	-25	-22.08	-46.81	-56.90	2.30	12.13	V
	7704	-47.11	-25	-22.11	-55.52	-55.73	2.11	10.73	V
	10272	-39.55	-25	-14.55	-54.9	-49.23	2.23	11.91	V
	12840	-35.43	-25	-10.43	-53.75	-45.80	2.52	12.89	V
									V
									V
									V

Remark: Spurious emissions within 30-1000MHz were found more than 20dB below limit line.



**Part27M LTE Band 7**

<For Aux. Antenna>

LTE Band 7 / 20MHz / QPSK									
Channel	Frequency ( MHz )	EIRP ( dBm )	Limit ( dBm )	Over Limit ( dB )	SPA Reading (dBm)	S.G. Power ( dBm )	TX Cable loss ( dB )	TX Antenna Gain (dBi)	Polarization (H/V)
Lowest	5040	-52.98	-25	-27.98	-52.3	-62.74	2.34	12.11	H
	7560	-52.97	-25	-27.97	-61.08	-61.07	2.11	10.22	H
	10080	-48.26	-25	-23.26	-62.87	-58.17	1.93	11.83	H
									H
									H
									H
	5040	-55.84	-25	-30.84	-55.16	-65.60	2.34	12.11	V
	7560	-52.37	-25	-27.37	-60.48	-60.47	2.11	10.22	V
	10080	-48.31	-25	-23.31	-62.92	-58.22	1.93	11.83	V
									V
									V
									V
Middle	5088	-49.64	-25	-24.64	-49.12	-59.43	2.32	12.12	H
	7632	-51.98	-25	-26.98	-60.24	-60.34	2.11	10.48	H
	10176	-47.89	-25	-22.89	-62.91	-57.68	2.08	11.87	H
									H
									H
									H
	5088	-58.89	-25	-33.89	-58.37	-68.68	2.32	12.12	V
	7632	-52.32	-25	-27.32	-60.58	-60.68	2.11	10.48	V
	10176	-47.65	-25	-22.65	-62.67	-57.44	2.08	11.87	V
									V
									V
									V



Highest	5136	-51.34	-25	-26.34	-51.07	-61.16	2.30	12.13	H
	7704	-52.42	-25	-27.42	-60.83	-61.04	2.11	10.73	H
	10272	-47.05	-25	-22.05	-62.4	-56.73	2.23	11.91	H
									H
									H
									H
									H
	5136	-58.99	-25	-33.99	-58.72	-68.81	2.30	12.13	V
	7704	-52.60	-25	-27.60	-61.01	-61.22	2.11	10.73	V
	10272	-46.23	-25	-21.23	-61.58	-55.91	2.23	11.91	V
									V
									V
									V
									V

Remark: Spurious emissions within 30-1000MHz were found more than 20dB below limit line.