



# FCC RF Test Report

**APPLICANT** : Motorola Mobility LLC  
**EQUIPMENT** : Mobile Cellular Phone  
**BRAND NAME** : Motorola  
**MODEL NAME** : XT1921-2  
**FCC ID** : IHDT56XC4  
**STANDARD** : FCC 47 CFR Part 2, 22(H), 24(E), 27(L)  
**CLASSIFICATION** : PCS Licensed Transmitter Held to Ear (PCE)

This is a variant report. The product was received on Dec. 20, 2017 and testing was completed on Jan. 16, 2018. We, SPORTON INTERNATIONAL INC., would like to declare that the tested sample has been evaluated in accordance with the test procedures given in ANSI / TIA-603-E and has been in compliance with the applicable technical standards.

The test results in this report apply exclusively to the tested model / sample. Without written approval of SPORTON INTERNATIONAL INC., the test report shall not be reproduced except in full.

Reviewed by: Joseph Lin / Supervisor

Approved by: Jones Tsai / Manager



## **SPORTON INTERNATIONAL INC.**

**No. 52, Hwa Ya 1<sup>st</sup> Rd., Hwa Ya Technology Park, Kwei-Shan District, Tao Yuan City, Taiwan, R.O.C.**

**SPORTON INTERNATIONAL INC.**

TEL : 886-3-327-3456

FAX : 886-3-328-4978

FCC ID : IHDT56XC4

Page Number : 1 of 22

Report Issued Date : Feb. 23, 2018

Report Version : Rev. 01

Report Template No.: BU5-FG22/24/27 Version 2.0



# TABLE OF CONTENTS

**REVISION HISTORY..... 3**

**SUMMARY OF TEST RESULT ..... 4**

**1 GENERAL DESCRIPTION ..... 5**

    1.1 Applicant..... 5

    1.2 Manufacturer ..... 5

    1.3 Product Feature of Equipment Under Test ..... 5

    1.4 Product Specification of Equipment Under Test ..... 6

    1.5 Modification of EUT ..... 6

    1.6 Maximum ERP/EIRP Power, Frequency Tolerance, and Emission Designator ..... 7

    1.7 Testing Location ..... 8

    1.8 Applicable Standards ..... 8

**2 TEST CONFIGURATION OF EQUIPMENT UNDER TEST ..... 9**

    2.1 Test Mode..... 9

    2.2 Connection Diagram of Test System ..... 10

    2.3 Support Unit used in test configuration ..... 10

    2.4 Measurement Results Explanation Example ..... 10

    2.5 Frequency List of Low/Middle/High Channels..... 11

**3 CONDUCTED TEST RESULT..... 12**

    3.1 Measuring Instruments..... 12

    3.2 Test Setup ..... 12

    3.3 Test Result of Conducted Test..... 12

    3.4 Conducted Output Power and ERP/EIRP ..... 13

    3.5 Peak-to-Average Ratio ..... 14

    3.6 99% Occupied Bandwidth and 26dB Bandwidth Measurement..... 15

    3.7 Conducted Band Edge ..... 16

    3.8 Conducted Spurious Emission ..... 17

    3.9 Frequency Stability..... 18

**4 RADIATED TEST ITEMS ..... 19**

    4.1 Measuring Instruments..... 19

    4.2 Test Setup ..... 19

    4.3 Test Result of Radiated Test..... 19

    4.4 Field Strength of Spurious Radiation Measurement ..... 20

**5 LIST OF MEASURING EQUIPMENT ..... 21**

**6 UNCERTAINTY OF EVALUATION ..... 22**

**APPENDIX A. TEST RESULTS OF CONDUCTED TEST**

**APPENDIX B. TEST RESULTS OF ERP/EIRP AND RADIATED TEST**

**APPENDIX C. ORIGINAL REPORT**



### REVISION HISTORY

REPORT NO.	VERSION	DESCRIPTION	ISSUED DATE
FG7D2018-02A	Rev. 01	Initial issue of report	Feb. 23, 2018



## SUMMARY OF TEST RESULT

Report Section	FCC Rule	Description	Limit	Result	Remark
3.4	§2.1046	Conducted Output Power	Reporting Only	PASS	-
	§22.913(a)(2)	Effective Radiated Power	< 7 Watts	PASS	-
	§24.232(c)	Equivalent Isotropic Radiated Power	< 2 Watts	PASS	-
	§27.50(d)(4)	Equivalent Isotropic Radiated Power	< 1 Watts	PASS	-
3.5	§24.232(d)	Peak-to-Average Ratio	< 13 dB	PASS	-
3.6	§2.1049 §22.917(b) §24.238(b) §27.53(g)	Occupied Bandwidth	Reporting Only	PASS	-
3.7	§2.1051 §22.917(a) §24.238(a) §27.53(h)	Band Edge Measurement	< 43+10log10(P[Watts])	PASS	-
3.8	§2.1051 §22.917(a) §24.238(a) §27.53(h)	Conducted Emission	< 43+10log10(P[Watts])	PASS	-
3.9	§2.1055 §22.355	Frequency Stability for Temperature & Voltage	< 2.5 ppm for Part 22	PASS	-
	§2.1055 §24.235 §27.54		Within Authorized Band		
4.4	§2.1053 §22.917(a) §24.238(a) §27.53(h)	Field Strength of Spurious Radiation	< 43+10log10(P[Watts])	PASS	Under limit 25.01 dB at 1696.000 MHz

**Remark:** This is a variant report which can be referred Product Equality Declaration. All the test cases were performed on original report which can be referred to Sporton Report Number FG7D2018A. Based on the original report, the test cases were verified.



# 1 General Description

## 1.1 Applicant

Motorola Mobility LLC  
222 W. Merchandise Mart Plaza, Chicago IL 60654, USA

## 1.2 Manufacturer

Motorola Mobility LLC  
222 W. Merchandise Mart Plaza, Chicago IL 60654, USA

## 1.3 Product Feature of Equipment Under Test

Product Feature	
Equipment	Mobile Cellular Phone
Brand Name	Motorola
Model Name	XT1921-2
FCC ID	IHDT56XC4
IMEI Code	351840090009840 (for Radiation) 351840090015086 (for Conducted)
EUT supports Radios application	GSM/EGPRS/WCDMA/HSPA/LTE/FM/GNSS WLAN 11b/g/n HT20 WLAN 11a/n HT20/HT40 Bluetooth BR/EDR/LE
HW Version	DVT1B
EUT Stage	Identical Prototype

**Remark:** The above EUT's information was declared by manufacturer. Please refer to the specifications or user's manual for more detailed description.

Accessory List	
AC Adapter 1	Brand Name : Motorola
	Model Name : C-P56
AC Adapter 2	Brand Name : Motorola
	Model Name : C-P56
Battery	Brand Name : Motorola
	Model Name : GK40
USB Cable	Brand Name : Saibao
	Model Name : SWT-A083A

### 1.4 Product Specification of Equipment Under Test

Standards-related Product Specification	
<b>Tx Frequency</b>	<b>GSM/GPRS/EDGE:</b> 850: 824.2 MHz ~ 848.8 MHz 1900: 1850.2 MHz ~ 1909.8MHz <b>WCDMA:</b> Band V: 826.4 MHz ~ 846.6 MHz Band II: 1852.4 MHz ~ 1907.6 MHz Band IV: 1712.4 MHz ~ 1752.6 MHz
<b>Rx Frequency</b>	<b>GSM/GPRS/EDGE:</b> 850: 869.2 MHz ~ 893.8 MHz 1900: 1930.2 MHz ~ 1989.8 MHz <b>WCDMA:</b> Band V: 871.4 MHz ~ 891.6 MHz Band II: 1932.4 MHz ~ 1987.6 MHz Band IV: 2112.4 MHz ~ 2152.6 MHz
<b>Maximum Output Power to Antenna</b>	<b>GSM/GPRS/EDGE:</b> 850: 33.34 dBm 1900: 30.73 dBm <b>WCDMA:</b> Band V: 22.72 dBm Band II: 23.19 dBm Band IV: 23.44 dBm
<b>Antenna Type</b>	PIFA Antenna and Coupling type (LDS) Antenna
<b>Antenna Gain</b>	Cellular Band: -0.71 dBi PCS Band: 1.82 dBi AWS Band: 1.58 dBi
<b>Type of Modulation</b>	GSM: GMSK GPRS: GMSK EDGE: GMSK / 8PSK WCDMA: BPSK (Uplink) HSDPA: 64QAM (Downlink) HSUPA: QPSK (Uplink)

### 1.5 Modification of EUT

No modifications are made to the EUT during all test items.



### 1.6 Maximum ERP/EIRP Power, Frequency Tolerance, and Emission Designator

FCC Rule	Frequency Range (MHz)	System	Type of Modulation	Maximum ERP/EIRP (W)	Frequency Tolerance (ppm)	Emission Designator
Part 22	824.2 ~848.8	GSM850 GPRS class 8	GMSK	1.1169	0.0084 ppm	247KGXW
Part 22	824.2 ~848.8	GSM850 EDGE class 8	8PSK	0.1945	0.0143 ppm	249KG7W
Part 22	826.4 ~846.6	WCDMA Band V RMC 12.2Kbps	BPSK	0.0968	0.0155 ppm	4M14F9W
Part 24	1850.2 ~1909.8	GSM1900 GPRS class 8	GMSK	1.7989	0.0122 ppm	246KGXW
Part 24	1850.2 ~1909.8	GSM1900 EDGE class 8	8PSK	0.4909	0.0059 ppm	247KG7W
Part 24	1852.4 ~ 1907.6	WCDMA Band II RMC 12.2Kbps	BPSK	0.3170	0.0096 ppm	4M17F9W
Part 27	1712.4 ~ 1752.6	WCDMA Band IV RMC 12.2Kbps	BPSK	0.3177	0.0237 ppm	4M15F9W



### 1.7 Testing Location

Sporton Lab is accredited to ISO 17025 by Taiwan Accreditation Foundation (TAF code : 1190) and the FCC designation No. TW1190 and TW0007 under the FCC 2.948(e) by Mutual Recognition Agreement (MRA) in FCC Test.

<b>Test Site</b>	SPORTON INTERNATIONAL INC.
<b>Test Site Location</b>	No. 52, Hwa Ya 1 <sup>st</sup> Rd., Hwa Ya Technology Park, Kwei-Shan District, Tao Yuan City, Taiwan, R.O.C. TEL: +886-3-327-3456 FAX: +886-3-328-4978
<b>Test Site No.</b>	<b>Sporton Site No.</b>
	TH03-HY

<b>Test Site</b>	SPORTON INTERNATIONAL INC.
<b>Test Site Location</b>	No.58, Aly. 75, Ln. 564, Wenhua 3rd Rd., Kwei-Shan District, Tao Yuan City, Taiwan R.O.C. TEL: +886-3-327-0868 FAX: +886-3-327-0855
<b>Test Site No.</b>	<b>Sporton Site No. :</b>
	03CH12-HY

### 1.8 Applicable Standards

According to the specifications of the manufacturer, the EUT must comply with the requirements of the following standards:

- ♦ 47 CFR Part 2, 22(H), 24(E), 27(L)
- ♦ ANSI / TIA-603-E
- ♦ FCC KDB 971168 D01 Power Meas. License Digital Systems v03
- ♦ FCC KDB 412172 D01 Determining ERP and EIRP v01r01

**Remark:**

1. All test items were verified and recorded according to the standards and without any deviation during the test.
2. This EUT has also been tested and complied with the requirements of FCC Part 15, Subpart B, recorded in a separate test report.





## 2 Test Configuration of Equipment Under Test

### 2.1 Test Mode

Antenna port conducted and radiated test items were performed according to KDB 971168 D01 Power Meas. License Digital Systems v03 with maximum output power.

Radiated measurements were performed with rotating EUT in different three orthogonal test planes to find the maximum emission.

Radiated emissions were investigated as following frequency range:

1. 30 MHz to 9000 MHz for GSM850 and WCDMA Band V.
2. 30 MHz to 18000 MHz for WCDMA Band IV.
3. 30 MHz to 19100 MHz for GSM1900 and WCDMA Band II.

All modes and data rates and positions were investigated.

Test modes are chosen to be reported as the worst case configuration below:

Test Modes		
Band	Radiated TCs	Conducted TCs
GSM 850	<ul style="list-style-type: none"> <li>■ GPRS class 8 Link</li> <li>■ EDGE class 8 Link</li> </ul>	<ul style="list-style-type: none"> <li>■ GPRS class 8 Link</li> <li>■ EDGE class 8 Link</li> </ul>
GSM 1900	<ul style="list-style-type: none"> <li>■ GPRS class 8 Link</li> <li>■ EDGE class 8 Link</li> </ul>	<ul style="list-style-type: none"> <li>■ GPRS class 8 Link</li> <li>■ EDGE class 8 Link</li> </ul>
WCDMA Band V	<ul style="list-style-type: none"> <li>■ RMC 12.2Kbps Link</li> </ul>	<ul style="list-style-type: none"> <li>■ RMC 12.2Kbps Link</li> </ul>
WCDMA Band II	<ul style="list-style-type: none"> <li>■ RMC 12.2Kbps Link</li> </ul>	<ul style="list-style-type: none"> <li>■ RMC 12.2Kbps Link</li> </ul>
WCDMA Band IV	<ul style="list-style-type: none"> <li>■ RMC 12.2Kbps Link</li> </ul>	<ul style="list-style-type: none"> <li>■ RMC 12.2Kbps Link</li> </ul>

**Remark:** All the radiated test cases were performance with Adapter 1.

## 2.2 Connection Diagram of Test System

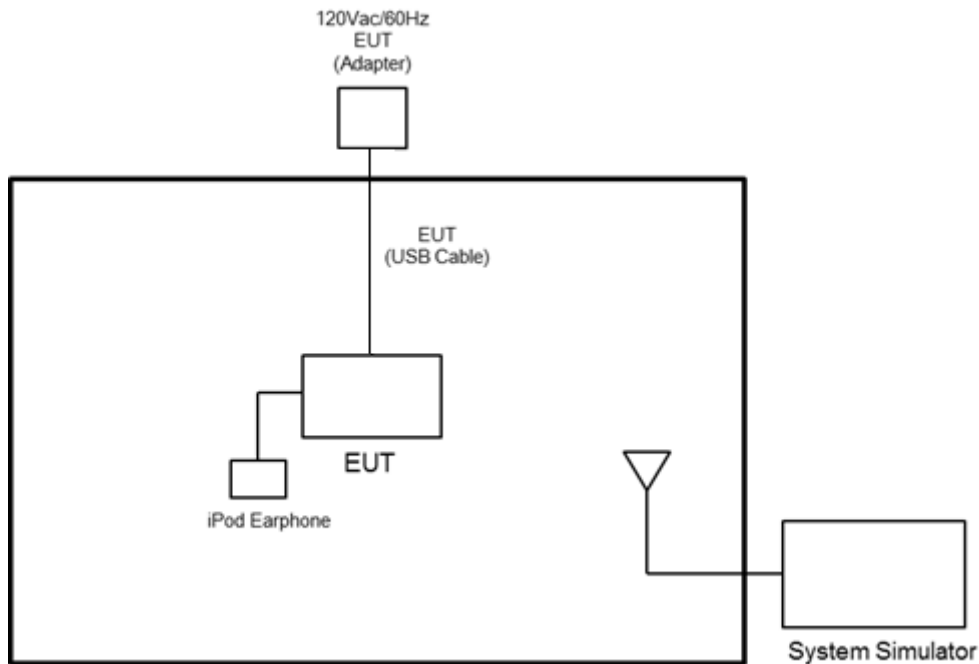

## 2.3 Support Unit used in test configuration

Item	Equipment	Trade Name	Model No.	FCC ID	Data Cable	Power Cord
1.	System Simulator	R&S	CMU 200	N/A	N/A	Unshielded, 1.8 m
2.	iPod Earphone	Apple	N/A	N/A	N/A	N/A

## 2.4 Measurement Results Explanation Example

### For all conducted test items:

The offset level is set in the spectrum analyzer to compensate the RF cable loss and attenuator factor between RF conducted output port and spectrum analyzer. With the offset compensation, the spectrum analyzer reading level will be exactly the RF output level.

The spectrum analyzer offset is derived from RF cable loss and attenuator factor.

$$\text{Offset} = \text{RF cable loss} + \text{attenuator factor}.$$

The following shows an offset computation example with RF cable loss 4.2 dB and a 10dB attenuator.

Example :

$$\begin{aligned} \text{Offset(dB)} &= \text{RF cable loss(dB)} + \text{attenuator factor(dB)}. \\ &= 4.2 + 10 = 14.2 \text{ (dB)} \end{aligned}$$



## 2.5 Frequency List of Low/Middle/High Channels

Frequency List				
Band	Channel/Frequency(MHz)	Lowest	Middle	Highest
GSM850	Channel	128	189	251
	Frequency	824.2	836.4	848.8
WCDMA Band V	Channel	4132	4182	4233
	Frequency	826.4	836.4	846.6
GSM1900	Channel	512	661	810
	Frequency	1850.2	1880.0	1909.8
WCDMA Band II	Channel	9262	9400	9538
	Frequency	1852.4	1880.0	1907.6
WCDMA Band IV	Channel	1312	1413	1513
	Frequency	1712.4	1732.6	1752.6

### 3 Conducted Test Result

#### 3.1 Measuring Instruments

See list of measuring instruments of this test report.

#### 3.2 Test Setup

##### 3.2.1 Conducted Output Power

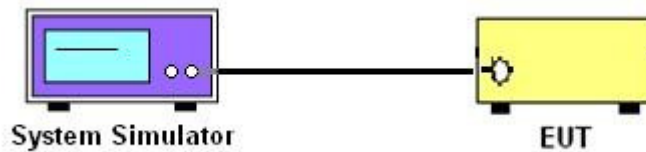

##### 3.2.2 Peak-to-Average Ratio, Occupied Bandwidth, Conducted Band-Edge and Conducted Spurious Emission

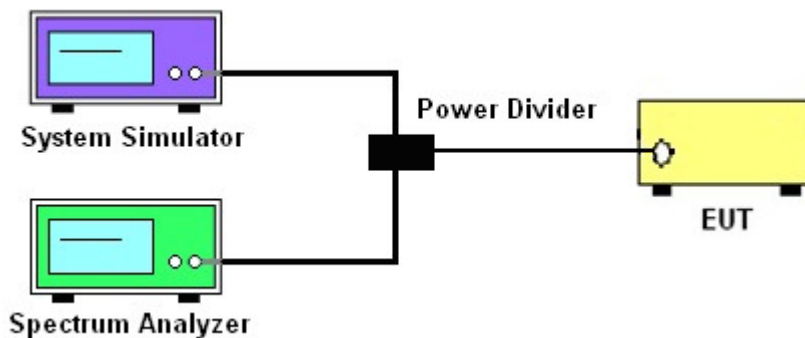

##### 3.2.3 Frequency Stability



### 3.3 Test Result of Conducted Test

Please refer to Appendix A.



### 3.4 Conducted Output Power and ERP/EIRP

#### 3.4.1 Description of the Conducted Output Power and ERP/EIRP

A system simulator was used to establish communication with the EUT. Its parameters were set to enforce EUT transmitting at the maximum power. The measured power in the radio frequency on the transmitter output terminals shall be reported.

The ERP of mobile transmitters must not exceed 7 Watts for GSM850 and WCDMA Band V.

The EIRP of mobile transmitters must not exceed 2 Watts for GSM1900 and WCDMA Band II.

The EIRP of mobile transmitters must not exceed 1 Watts for WCDMA Band IV.

According to KDB 412172 D01 Power Approach,

$EIRP = P_T + G_T - L_C$ ,  $ERP = EIRP - 2.15$ , where

$P_T$  = transmitter output power in dBm

$G_T$  = gain of the transmitting antenna in dBi

$L_C$  = signal attenuation in the connecting cable between the transmitter and antenna in dB

#### 3.4.2 Test Procedures

1. The transmitter output port was connected to the system simulator.
2. Set EUT at maximum power through system simulator.
3. Select lowest, middle, and highest channels for each band and different modulation.
4. Measure the maximum burst average power for GSM and maximum average power for other modulation signal.



## **3.5 Peak-to-Average Ratio**

### **3.5.1 Description of the PAR Measurement**

The peak-to-average ratio (PAR) of the transmission may not exceed 13 dB.

### **3.5.2 Test Procedures**

1. The testing follows FCC KDB 971168 D01 v03 Section 5.7.1.
2. The EUT was connected to spectrum analyzer and system simulator via a power divider.
3. Set EUT to transmit at maximum output power.
4. When the duty cycle is less than 98%, then signal gating will be implemented on the spectrum analyzer by triggering from the system simulator.
5. Set the CCDF (Complementary Cumulative Distribution Function) option of the spectrum analyzer.  
Record the maximum PAPR level associated with a probability of 0.1%.



## 3.6 99% Occupied Bandwidth and 26dB Bandwidth Measurement

### 3.6.1 Description of 99% Occupied Bandwidth and 26dB Bandwidth Measurement

The occupied bandwidth is the width of a frequency band such that, below the lower and above the upper frequency limits, the mean powers emitted are each equal to a specified percentage 0.5% of the total mean transmitted power.

The 26 dB emission bandwidth is defined as the frequency range between two points, one above and one below the carrier frequency, at which the spectral density of the emission is attenuated 26 dB below the maximum in-band spectral density of the modulated signal. Spectral density (power per unit bandwidth) is to be measured with a detector of resolution bandwidth equal to approximately 1.0% of the emission bandwidth.

### 3.6.2 Test Procedures

1. The testing follows FCC KDB 971168 v03 Section 4.2.
2. The EUT was connected to spectrum analyzer and system simulator via a power divider.
3. The spectrum analyzer center frequency is set to the nominal EUT channel center frequency. The span range for the spectrum analyzer shall be between two and five times the anticipated OBW.
4. The nominal resolution bandwidth (RBW) shall be in the range of 1 to 5 % of the anticipated OBW, and the VBW shall be at least 3 times the RBW.
5. Set the detection mode to peak, and the trace mode to max hold.
6. Determine the reference value: Set the EUT to transmit a modulated signal. Allow the trace to stabilize. Set the spectrum analyzer marker to the highest level of the displayed trace.  
(this is the reference value)
7. Determine the “-26 dB down amplitude” as equal to (Reference Value – X).
8. Place two markers, one at the lowest and the other at the highest frequency of the envelope of the spectral display such that each marker is at or slightly below the “-X dB down amplitude” determined in step 6. If a marker is below this “-X dB down amplitude” value it shall be placed as close as possible to this value. The OBW is the positive frequency difference between the two markers.
9. Use the 99 % power bandwidth function of the spectrum analyzer and report the measured bandwidth.



### **3.7 Conducted Band Edge**

#### **3.7.1 Description of Conducted Band Edge Measurement**

The power of any emission outside of the authorized operating frequency ranges must be lower than the transmitter power (P) by a factor of at least  $43 + 10 \log (P)$  dB.

#### **3.7.2 Test Procedures**

1. The testing follows FCC KDB 971168 D01 v03 Section 6.0.
2. The EUT was connected to the spectrum analyzer and system simulator via a power divider.
3. The RF output of EUT was connected to the spectrum analyzer by an RF cable and attenuator. The path loss was compensated to the results for each measurement.
4. The band edges of low and high channels for the highest RF powers were measured.
5. The RF fundamental frequency should be excluded against the limit line in the operating frequency band.
6. The limit line is derived from  $43 + 10\log(P)$  dB below the transmitter power P(Watts)





### 3.8 Conducted Spurious Emission

#### 3.8.1 Description of Conducted Spurious Emission Measurement

The power of any emission outside of the authorized operating frequency ranges must be lower than the transmitter power (P) by a factor of at least  $43 + 10 \log (P)$  dB.

It is measured by means of a calibrated spectrum analyzer and scanned from 30 MHz up to a frequency including its 10<sup>th</sup> harmonic.

#### 3.8.2 Test Procedures

1. The testing follows FCC KDB 971168 D01 v03 Section 6.0.
2. The EUT was connected to the spectrum analyzer and system simulator via a power divider.
3. The RF output of EUT was connected to the spectrum analyzer by an RF cable and attenuator. The path loss was compensated to the results for each measurement.
4. The middle channel for the highest RF power within the transmitting frequency was measured.
5. The conducted spurious emission for the whole frequency range was taken.
6. The RF fundamental frequency should be excluded against the limit line in the operating frequency band.
7. The limit line is derived from  $43 + 10\log(P)$  dB below the transmitter power P(Watts)



### 3.9 Frequency Stability

#### 3.9.1 Description of Frequency Stability Measurement

The frequency stability shall be measured by variation of ambient temperature and variation of primary supply voltage to ensure that the fundamental emission stays within the authorized frequency block. The frequency stability of the transmitter shall be maintained within  $\pm 0.00025\%$  ( $\pm 2.5\text{ppm}$ ) of the center frequency.

#### 3.9.2 Test Procedures for Temperature Variation

1. The testing follows FCC KDB 971168 D01 v03 Section 9.0.
2. The EUT was set up in the thermal chamber and connected with the system simulator.
3. With power OFF, the temperature was decreased to  $-30^{\circ}\text{C}$  and the EUT was stabilized before testing. Power was applied and the maximum change in frequency was recorded within one minute.
4. With power OFF, the temperature was raised in  $10^{\circ}\text{C}$  steps up to  $50^{\circ}\text{C}$ . The EUT was stabilized at each step for at least half an hour. Power was applied and the maximum frequency change was recorded within one minute.

#### 3.9.3 Test Procedures for Voltage Variation

1. The testing follows FCC KDB 971168 D01 v03 Section 9.0.
2. The EUT was placed in a temperature chamber at  $20\pm 5^{\circ}\text{C}$  and connected with the system simulator.
3. The power supply voltage to the EUT was varied from 85% to 115% of the nominal value measured at the input to the EUT.
4. The variation in frequency was measured for the worst case.

## 4 Radiated Test Items

### 4.1 Measuring Instruments

See list of measuring instruments of this test report.

### 4.2 Test Setup

#### 4.2.1 For radiated test from 30MHz to 1GHz



#### 4.2.2 For radiated test above 1GHz

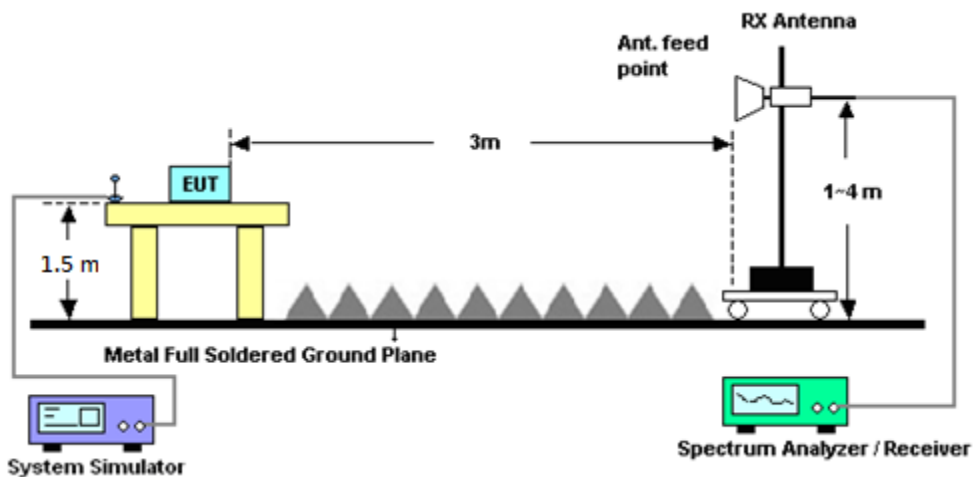

### 4.3 Test Result of Radiated Test

Please refer to Appendix B.



## 4.4 Field Strength of Spurious Radiation Measurement

### 4.4.1 Description of Field Strength of Spurious Radiated Measurement

The power of any emission outside of the authorized operating frequency ranges must be attenuated below the transmitter power (P) by a factor of at least  $43 + 10 \log (P)$  dB. The spectrum is scanned from 30 MHz up to a frequency including its 10th harmonic.

### 4.4.2 Test Procedures

1. The testing follows FCC KDB 971168 D01 v03 Section 5.8 and ANSI / TIA-603-E Section 2.2.12.
2. The EUT was placed on a rotatable wooden table 0.8 meters for frequency below 1GHz and 1.5 meter for frequency above 1GHz above the ground.
3. The EUT was set 3 meters from the receiving antenna, which was mounted on the antenna tower.
4. The table was rotated 360 degrees to determine the position of the highest spurious emission.
5. The height of the receiving antenna is varied between one meter and four meters to search for the maximum spurious emission for both horizontal and vertical polarizations.
6. Make the measurement with the spectrum analyzer's RBW = 1MHz, VBW = 3MHz, taking record of maximum spurious emission.
7. A horn antenna was substituted in place of the EUT and was driven by a signal generator.
8. Tune the output power of signal generator to the same emission level with EUT maximum spurious emission.
9. Taking the record of output power at antenna port.
10. Repeat step 7 to step 8 for another polarization.
11.  $EIRP \text{ (dBm)} = S.G. \text{ Power} - Tx \text{ Cable Loss} + Tx \text{ Antenna Gain}$
12.  $ERP \text{ (dBm)} = EIRP - 2.15$
13. The RF fundamental frequency should be excluded against the limit line in the operating frequency band.
14. The limit line is derived from  $43 + 10\log(P)$  dB below the transmitter power P(Watts)



## 5 List of Measuring Equipment

Instrument	Manufacturer	Model No.	Serial No.	Characteristics	Calibration Date	Test Date	Due Date	Remark
Spectrum Analyzer	Rohde & Schwarz	FSP30	101329	9kHz~30GHz	Jun. 26, 2017	Jan. 14, 2018~ Jan. 15, 2018	Jun. 25, 2018	Conducted (TH03-HY)
Temperature Chamber	ESPEC	SU-641	92013721	-30℃ ~70℃	Nov. 16, 2016	Jan. 14, 2018~ Jan. 15, 2018	Nov. 15, 2018	Conducted (TH03-HY)
Programmable Power Supply	GW Instek	PSS-2005	EL883644	Voltage:0~20V;Current:0~5A	Nov. 22, 2016	Jan. 14, 2018~ Jan. 15, 2018	Nov. 21, 2018	Conducted (TH03-HY)
Base Station(Measure)	Rohde & Schwarz	CMU200	117995	GSM / GPRS / WCDMA / CDMA	Aug. 09, 2017	Jan. 14, 2018~ Jan. 15, 2018	Aug. 08, 2018	Conducted (TH03-HY)
Amplifier	MITEQ	TTA1840-35-HG	1871923	18GHz~40GHz,VS WR : 2.5:1 max	Jul. 18, 2017	Jan. 15, 2018 ~ Jan. 16, 2018	Jul. 17, 2018	Radiation (03CH12-HY)
Bilog Antenna	TESEQ	CBL 6111D&00800N1D01N-06	35413&02	30MHz~1GHz	Dec. 18, 2017	Jan. 15, 2018 ~ Jan. 16, 2018	Dec. 17, 2018	Radiation (03CH12-HY)
Horn Antenna	SCHWARZBECK	BBHA 9120D	9120D-1328	1GHz ~ 18GHz	Oct. 20, 2017	Jan. 15, 2018 ~ Jan. 16, 2018	Oct. 19, 2018	Radiation (03CH12-HY)
Preamplifier	COM-POWER	PA-103	161075	10MHz~1GHz	Mar. 23, 2017	Jan. 15, 2018 ~ Jan. 16, 2018	Mar. 22, 2018	Radiation (03CH12-HY)
Preamplifier	Agilent	8449B	3008A02375	1GHz~26.5GHz	Dec. 19, 2017	Jan. 15, 2018 ~ Jan. 16, 2018	Dec. 18, 2018	Radiation (03CH12-HY)
Antenna Mast	EMEC	AM-BS-4500-B	N/A	1m~4m	N/A	Jan. 15, 2018 ~ Jan. 16, 2018	N/A	Radiation (03CH12-HY)
Turn Table	EMEC	TT2000	N/A	0~360 Degree	N/A	Jan. 15, 2018 ~ Jan. 16, 2018	N/A	Radiation (03CH12-HY)
SHF-EHF Horn Antenna	SCHWARZBECK	BBHA 9170	BBHA9170576	18GHz ~ 40GHz	Apr. 27, 2017	Jan. 15, 2018 ~ Jan. 16, 2018	Apr. 26, 2018	Radiation (03CH12-HY)
Spectrum Analyzer	Agilent	N9030A	MY52350276	3Hz~44GHz	Mar. 23, 2017	Jan. 15, 2018 ~ Jan. 16, 2018	Mar. 22, 2018	Radiation (03CH12-HY)
Horn Antenna	SCHWARZBECK	BBHA 9120D	BBHA 9120D 1212	1GHz ~ 18GHz	Mar. 17, 2017	Jan. 15, 2018 ~ Jan. 16, 2018	Mar. 16, 2018	Radiation (03CH12-HY)
SHF-EHF Horn Antenna	SCHWARZBECK	BBHA 9170	BBHA9170584	18GHz- 40GHz	Nov. 27, 2017	Jan. 15, 2018 ~ Jan. 16, 2018	Nov. 26, 2018	Radiation (03CH12-HY)
Signal Generator	Rohde & Schwarz	SMF100A	101107	100kHz~40GHz	May 22, 2017	Jan. 15, 2018 ~ Jan. 16, 2018	May 21, 2018	Radiation (03CH12-HY)



## 6 Uncertainty of Evaluation

### Uncertainty of Radiated Emission Measurement (30 MHz ~ 1000 MHz)

Measuring Uncertainty for a Level of Confidence of 95% ( $U = 2Uc(y)$ )	3.36
---	------

### Uncertainty of Radiated Emission Measurement (1 GHz ~ 18 GHz)

Measuring Uncertainty for a Level of Confidence of 95% ( $U = 2Uc(y)$ )	3.70
---	------

### Uncertainty of Radiated Emission Measurement (18 GHz ~ 40 GHz)

Measuring Uncertainty for a Level of Confidence of 95% ( $U = 2Uc(y)$ )	3.98
---	------



## Appendix A. Test Results of Conducted Test

### Conducted Output Power(Average power)

Conducted Power (*Unit: dBm)						
Band	GSM850			GSM1900		
Channel	128	189	251	512	661	810
Frequency	824.2	836.4	848.8	1850.2	1880	1909.8
GSM	33.28	33.31	33.11	30.52	30.72	30.61
GPRS class 8	33.28	<b>33.34</b>	33.15	30.54	<b>30.73</b>	30.62
GPRS class 10	29.73	29.80	29.90	27.06	27.58	27.46
GPRS class 11	27.74	27.71	27.72	25.22	25.54	25.46
GPRS class 12	26.17	26.22	26.33	23.87	24.14	24.17
EGPRS class 8	25.67	25.69	<b>25.75</b>	24.77	<b>25.09</b>	25.04
EGPRS class 10	25.41	25.44	25.49	24.55	24.90	24.81
EGPRS class 11	24.46	24.44	24.55	23.87	24.14	24.06
EGPRS class 12	23.06	23.08	23.10	22.36	22.71	22.62

Conducted Power (*Unit: dBm)						
Band	WCDMA Band V			WCDMA Band II		
Channel	4132	4182	4233	9262	9400	9538
Frequency	826.4	836.4	846.6	1852.4	1880	1907.6
RMC 12.2K	22.59	22.56	<b>22.72</b>	22.87	<b>23.19</b>	23.01
HSDPA Subtest-1	21.58	21.43	21.61	21.85	22.19	21.93
HSDPA Subtest-2	21.59	21.47	21.59	21.84	22.21	21.91
HSDPA Subtest-3	21.06	20.95	21.06	21.36	21.72	21.41
HSDPA Subtest-4	21.04	20.91	21.14	21.37	21.69	21.39
HSUPA Subtest-1	21.58	21.47	21.60	21.83	22.18	21.90
HSUPA Subtest-2	19.57	19.49	19.61	19.83	20.19	19.94
HSUPA Subtest-3	20.62	20.45	20.58	20.86	21.16	20.91
HSUPA Subtest-4	19.60	19.44	19.63	19.78	20.20	19.94
HSUPA Subtest-5	21.60	21.50	21.60	21.80	22.20	21.90



Conducted Power (*Unit: dBm)			
Band	WCDMA Band IV		
Channel	1312	1413	1513
Frequency	1712.4	1732.6	1752.6
RMC 12.2K	22.95	23.24	23.44
HSDPA Subtest-1	21.92	22.26	22.58
HSDPA Subtest-2	21.88	22.22	22.46
HSDPA Subtest-3	21.50	21.78	22.06
HSDPA Subtest-4	21.53	21.74	21.98
HSUPA Subtest-1	21.85	22.21	22.03
HSUPA Subtest-2	19.93	20.25	20.08
HSUPA Subtest-3	20.91	21.21	21.02
HSUPA Subtest-4	19.88	20.23	20.13
HSUPA Subtest-5	21.90	22.20	22.10





## A2. GSM

### Peak-to-Average Ratio

Mode	GSM850		Limit: 13dB
Mod.	GPRS class 8	EDGE class 8	Result
Lowest CH	0.44	3.64	PASS
Middle CH	0.44	3.60	
Highest CH	0.48	3.56	

Mode	GSM1900		Limit: 13dB
Mod.	GPRS class 8	EDGE class 8	Result
Lowest CH	0.40	3.44	PASS
Middle CH	0.36	3.52	
Highest CH	0.36	3.56	

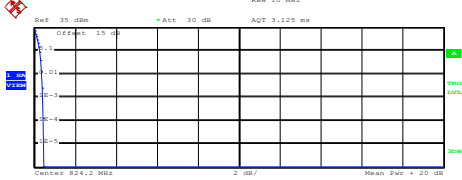
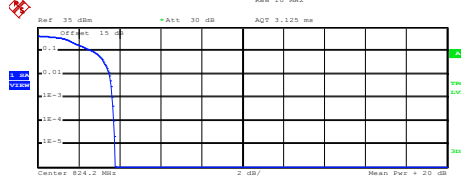
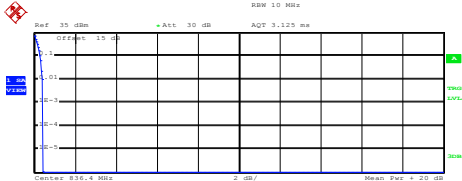
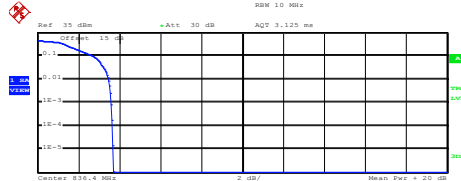
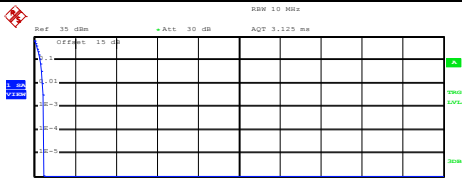
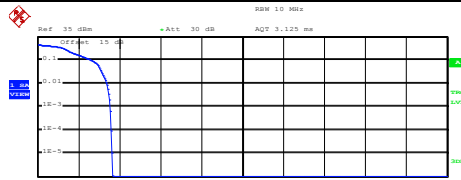

GSM850 (GPRS class 8)	GSM850 (EDGE class 8)																
<p align="center"><b>Lowest Channel</b></p>  <p>Center 824.2 MHz      2 dB/      Mean Pwr + 20 dB</p> <p>Complementary Cumulative Distribution Function (100000 samples) Trace 1 Mean 31.32 dBm Peak 31.77 dBm Crest 0.44 dB</p> <table border="0"> <tr><td>10 %</td><td>0.28 dB</td></tr> <tr><td>1 %</td><td>0.36 dB</td></tr> <tr><td>.1 %</td><td>0.44 dB</td></tr> <tr><td>.01 %</td><td>0.44 dB</td></tr> </table> <p>Date: 14.JAN.2018 14:51:21</p>	10 %	0.28 dB	1 %	0.36 dB	.1 %	0.44 dB	.01 %	0.44 dB	<p align="center"><b>Lowest Channel</b></p>  <p>Center 824.2 MHz      2 dB/      Mean Pwr + 20 dB</p> <p>Complementary Cumulative Distribution Function (100000 samples) Trace 1 Mean 24.05 dBm Peak 27.81 dBm Crest 3.76 dB</p> <table border="0"> <tr><td>10 %</td><td>2.68 dB</td></tr> <tr><td>1 %</td><td>3.52 dB</td></tr> <tr><td>.1 %</td><td>3.64 dB</td></tr> <tr><td>.01 %</td><td>3.72 dB</td></tr> </table> <p>Date: 14.JAN.2018 15:14:31</p>	10 %	2.68 dB	1 %	3.52 dB	.1 %	3.64 dB	.01 %	3.72 dB
10 %	0.28 dB																
1 %	0.36 dB																
.1 %	0.44 dB																
.01 %	0.44 dB																
10 %	2.68 dB																
1 %	3.52 dB																
.1 %	3.64 dB																
.01 %	3.72 dB																
<p align="center"><b>Middle Channel</b></p>  <p>Center 836.4 MHz      2 dB/      Mean Pwr + 20 dB</p> <p>Complementary Cumulative Distribution Function (100000 samples) Trace 1 Mean 31.19 dBm Peak 31.62 dBm Crest 0.43 dB</p> <table border="0"> <tr><td>10 %</td><td>0.28 dB</td></tr> <tr><td>1 %</td><td>0.40 dB</td></tr> <tr><td>.1 %</td><td>0.44 dB</td></tr> <tr><td>.01 %</td><td>0.44 dB</td></tr> </table> <p>Date: 14.JAN.2018 14:51:36</p>	10 %	0.28 dB	1 %	0.40 dB	.1 %	0.44 dB	.01 %	0.44 dB	<p align="center"><b>Middle Channel</b></p>  <p>Center 836.4 MHz      2 dB/      Mean Pwr + 20 dB</p> <p>Complementary Cumulative Distribution Function (100000 samples) Trace 1 Mean 24.07 dBm Peak 27.74 dBm Crest 3.68 dB</p> <table border="0"> <tr><td>10 %</td><td>2.72 dB</td></tr> <tr><td>1 %</td><td>3.48 dB</td></tr> <tr><td>.1 %</td><td>3.60 dB</td></tr> <tr><td>.01 %</td><td>3.68 dB</td></tr> </table> <p>Date: 14.JAN.2018 15:14:50</p>	10 %	2.72 dB	1 %	3.48 dB	.1 %	3.60 dB	.01 %	3.68 dB
10 %	0.28 dB																
1 %	0.40 dB																
.1 %	0.44 dB																
.01 %	0.44 dB																
10 %	2.72 dB																
1 %	3.48 dB																
.1 %	3.60 dB																
.01 %	3.68 dB																
<p align="center"><b>Highest Channel</b></p>  <p>Center 848.8 MHz      2 dB/      Mean Pwr + 20 dB</p> <p>Complementary Cumulative Distribution Function (100000 samples) Trace 1 Mean 31.24 dBm Peak 31.70 dBm Crest 0.46 dB</p> <table border="0"> <tr><td>10 %</td><td>0.28 dB</td></tr> <tr><td>1 %</td><td>0.40 dB</td></tr> <tr><td>.1 %</td><td>0.48 dB</td></tr> <tr><td>.01 %</td><td>0.48 dB</td></tr> </table> <p>Date: 14.JAN.2018 14:51:52</p>	10 %	0.28 dB	1 %	0.40 dB	.1 %	0.48 dB	.01 %	0.48 dB	<p align="center"><b>Highest Channel</b></p>  <p>Center 848.8 MHz      2 dB/      Mean Pwr + 20 dB</p> <p>Complementary Cumulative Distribution Function (100000 samples) Trace 1 Mean 24.11 dBm Peak 27.74 dBm Crest 3.64 dB</p> <table border="0"> <tr><td>10 %</td><td>2.68 dB</td></tr> <tr><td>1 %</td><td>3.40 dB</td></tr> <tr><td>.1 %</td><td>3.56 dB</td></tr> <tr><td>.01 %</td><td>3.60 dB</td></tr> </table> <p>Date: 14.JAN.2018 15:15:08</p>	10 %	2.68 dB	1 %	3.40 dB	.1 %	3.56 dB	.01 %	3.60 dB
10 %	0.28 dB																
1 %	0.40 dB																
.1 %	0.48 dB																
.01 %	0.48 dB																
10 %	2.68 dB																
1 %	3.40 dB																
.1 %	3.56 dB																
.01 %	3.60 dB																

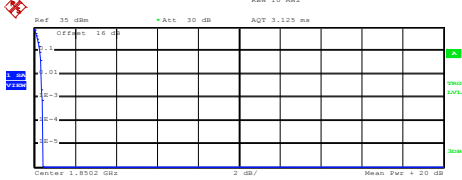
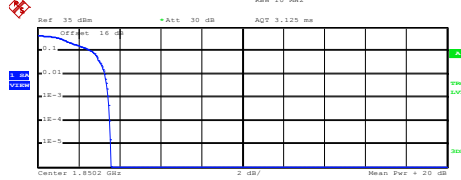
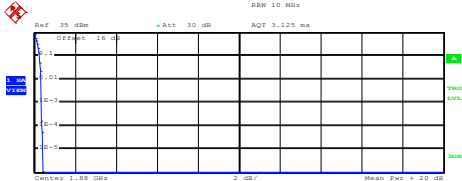
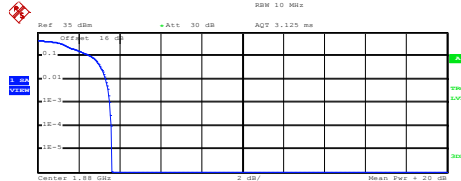
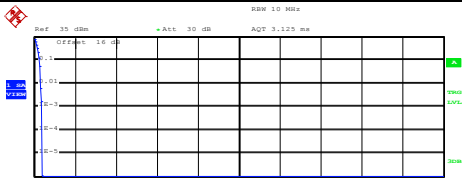
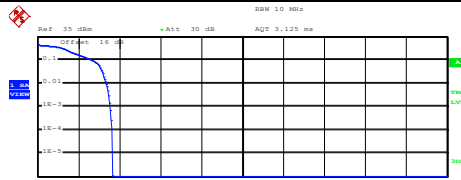

GSM1900 (GPRS class 8)	GSM1900 (EDGE class 8)																
<p align="center"><b>Lowest Channel</b></p>  <p>Center 1.8502 GHz    2 dB/    Mean Pwr + 20 dB</p> <p>Complementary Cumulative Distribution Function (100000 samples) Trace 1 Mean 28.34 dBm Peak 28.76 dBm Crest 0.42 dB</p> <table border="1"> <tr><td>10 %</td><td>0.28 dB</td></tr> <tr><td>1 %</td><td>0.36 dB</td></tr> <tr><td>.1 %</td><td>0.40 dB</td></tr> <tr><td>.01 %</td><td>0.44 dB</td></tr> </table> <p>Date: 15.JAN.2018 08:53:09</p>	10 %	0.28 dB	1 %	0.36 dB	.1 %	0.40 dB	.01 %	0.44 dB	<p align="center"><b>Lowest Channel</b></p>  <p>Center 1.8502 GHz    2 dB/    Mean Pwr + 20 dB</p> <p>Complementary Cumulative Distribution Function (100000 samples) Trace 1 Mean 23.02 dBm Peak 26.62 dBm Crest 3.59 dB</p> <table border="1"> <tr><td>10 %</td><td>2.64 dB</td></tr> <tr><td>1 %</td><td>3.28 dB</td></tr> <tr><td>.1 %</td><td>3.44 dB</td></tr> <tr><td>.01 %</td><td>3.52 dB</td></tr> </table> <p>Date: 14.JAN.2018 15:31:56</p>	10 %	2.64 dB	1 %	3.28 dB	.1 %	3.44 dB	.01 %	3.52 dB
10 %	0.28 dB																
1 %	0.36 dB																
.1 %	0.40 dB																
.01 %	0.44 dB																
10 %	2.64 dB																
1 %	3.28 dB																
.1 %	3.44 dB																
.01 %	3.52 dB																
<p align="center"><b>Middle Channel</b></p>  <p>Center 1.88 GHz    2 dB/    Mean Pwr + 20 dB</p> <p>Complementary Cumulative Distribution Function (100000 samples) Trace 1 Mean 28.76 dBm Peak 29.18 dBm Crest 0.42 dB</p> <table border="1"> <tr><td>10 %</td><td>0.24 dB</td></tr> <tr><td>1 %</td><td>0.36 dB</td></tr> <tr><td>.1 %</td><td>0.36 dB</td></tr> <tr><td>.01 %</td><td>0.40 dB</td></tr> </table> <p>Date: 15.JAN.2018 08:53:26</p>	10 %	0.24 dB	1 %	0.36 dB	.1 %	0.36 dB	.01 %	0.40 dB	<p align="center"><b>Middle Channel</b></p>  <p>Center 1.88 GHz    2 dB/    Mean Pwr + 20 dB</p> <p>Complementary Cumulative Distribution Function (100000 samples) Trace 1 Mean 23.28 dBm Peak 26.90 dBm Crest 3.61 dB</p> <table border="1"> <tr><td>10 %</td><td>2.60 dB</td></tr> <tr><td>1 %</td><td>3.32 dB</td></tr> <tr><td>.1 %</td><td>3.52 dB</td></tr> <tr><td>.01 %</td><td>3.60 dB</td></tr> </table> <p>Date: 14.JAN.2018 15:32:14</p>	10 %	2.60 dB	1 %	3.32 dB	.1 %	3.52 dB	.01 %	3.60 dB
10 %	0.24 dB																
1 %	0.36 dB																
.1 %	0.36 dB																
.01 %	0.40 dB																
10 %	2.60 dB																
1 %	3.32 dB																
.1 %	3.52 dB																
.01 %	3.60 dB																
<p align="center"><b>Highest Channel</b></p>  <p>Center 1.9098 GHz    2 dB/    Mean Pwr + 20 dB</p> <p>Complementary Cumulative Distribution Function (100000 samples) Trace 1 Mean 28.59 dBm Peak 28.97 dBm Crest 0.38 dB</p> <table border="1"> <tr><td>10 %</td><td>0.24 dB</td></tr> <tr><td>1 %</td><td>0.32 dB</td></tr> <tr><td>.1 %</td><td>0.36 dB</td></tr> <tr><td>.01 %</td><td>0.40 dB</td></tr> </table> <p>Date: 15.JAN.2018 08:53:44</p>	10 %	0.24 dB	1 %	0.32 dB	.1 %	0.36 dB	.01 %	0.40 dB	<p align="center"><b>Highest Channel</b></p>  <p>Center 1.9098 GHz    2 dB/    Mean Pwr + 20 dB</p> <p>Complementary Cumulative Distribution Function (100000 samples) Trace 1 Mean 23.09 dBm Peak 26.76 dBm Crest 3.66 dB</p> <table border="1"> <tr><td>10 %</td><td>2.68 dB</td></tr> <tr><td>1 %</td><td>3.36 dB</td></tr> <tr><td>.1 %</td><td>3.56 dB</td></tr> <tr><td>.01 %</td><td>3.64 dB</td></tr> </table> <p>Date: 14.JAN.2018 15:32:30</p>	10 %	2.68 dB	1 %	3.36 dB	.1 %	3.56 dB	.01 %	3.64 dB
10 %	0.24 dB																
1 %	0.32 dB																
.1 %	0.36 dB																
.01 %	0.40 dB																
10 %	2.68 dB																
1 %	3.36 dB																
.1 %	3.56 dB																
.01 %	3.64 dB																



**26dB Bandwidth**

Mode	GSM850	
Mod.	GPRS class 8	EDGE class 8
Lowest CH	0.315	0.306
Middle CH	0.312	0.292
Highest CH	0.310	0.297

Mode	GSM1900	
Mod.	GPRS class 8	EDGE class 8
Lowest CH	0.308	0.303
Middle CH	0.310	0.309
Highest CH	0.313	0.305

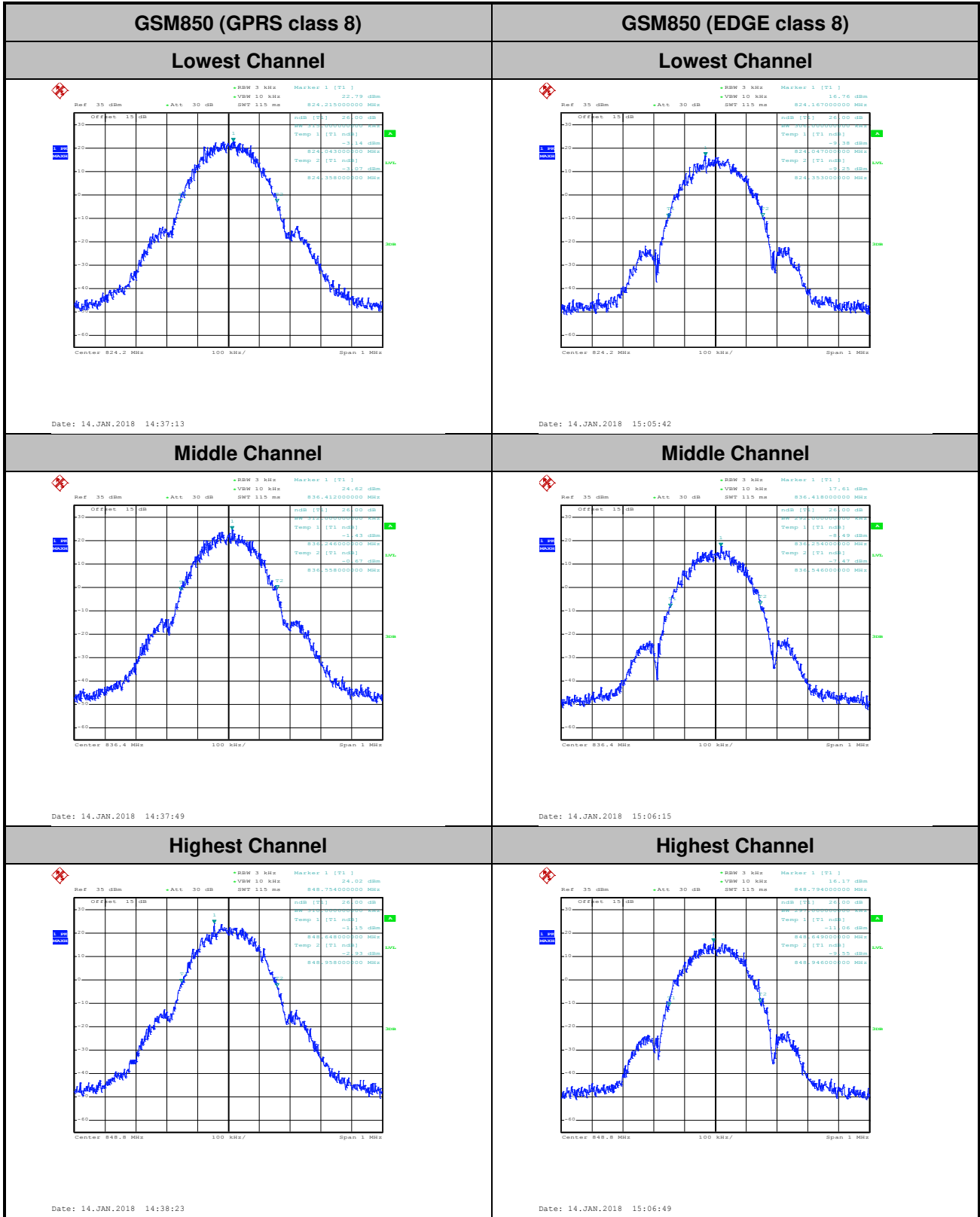

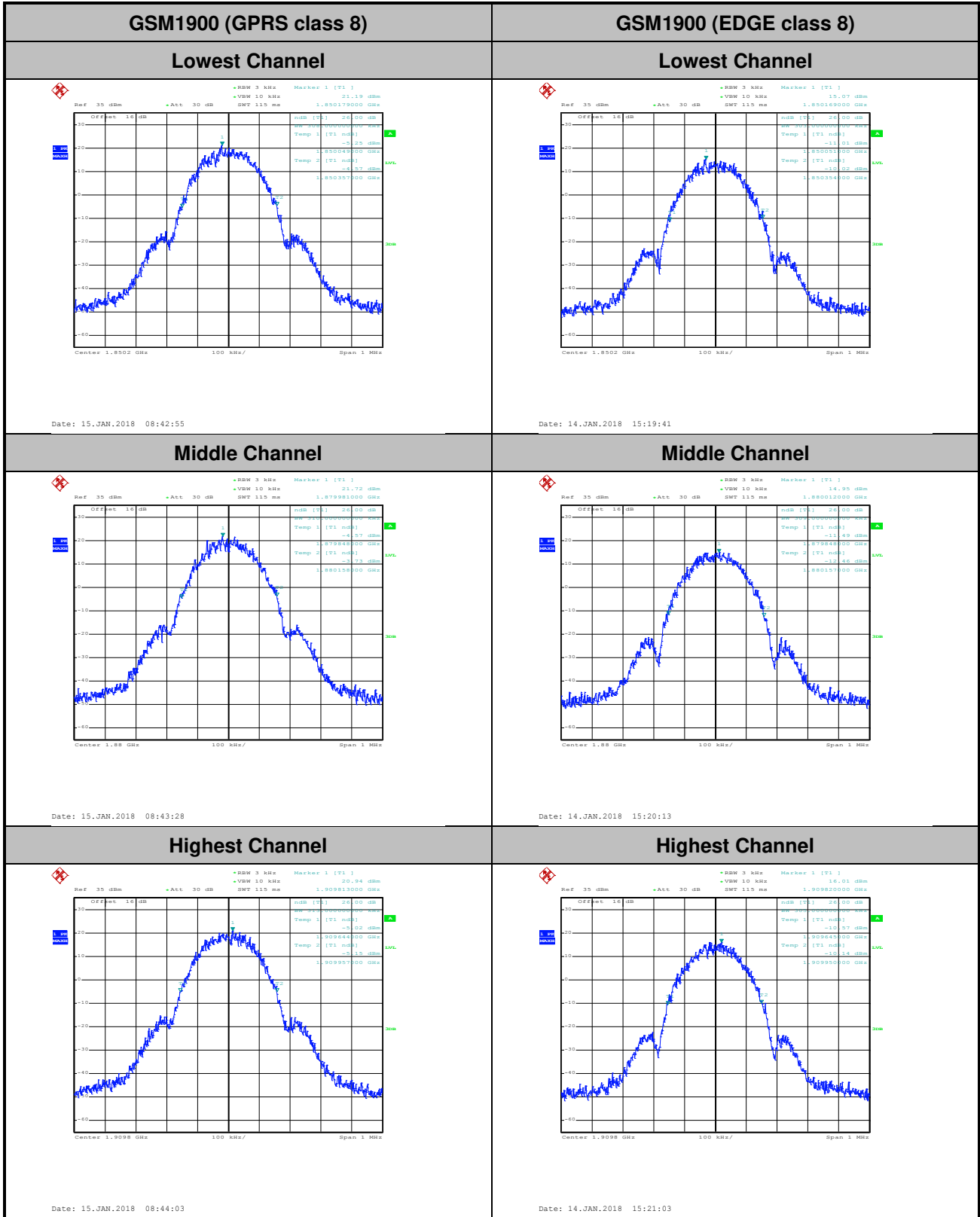



### Occupied Bandwidth

Mode	GSM850	
Mod.	GPRS class 8	EDGE class 8
Lowest CH	0.246	0.249
Middle CH	0.246	0.245
Highest CH	0.247	0.243

Mode	GSM1900	
Mod.	GPRS class 8	EDGE class 8
Lowest CH	0.241	0.243
Middle CH	0.246	0.244
Highest CH	0.244	0.247

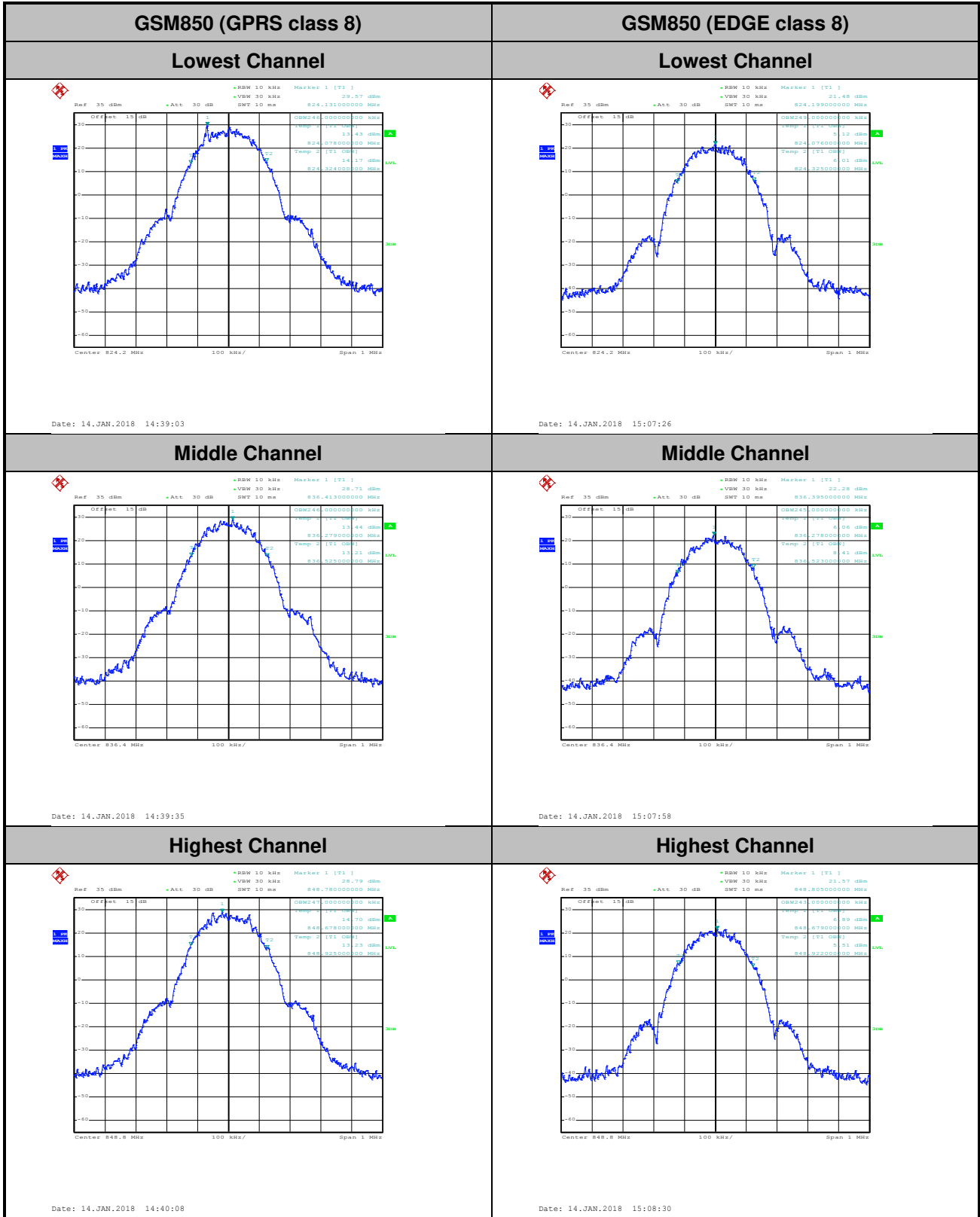



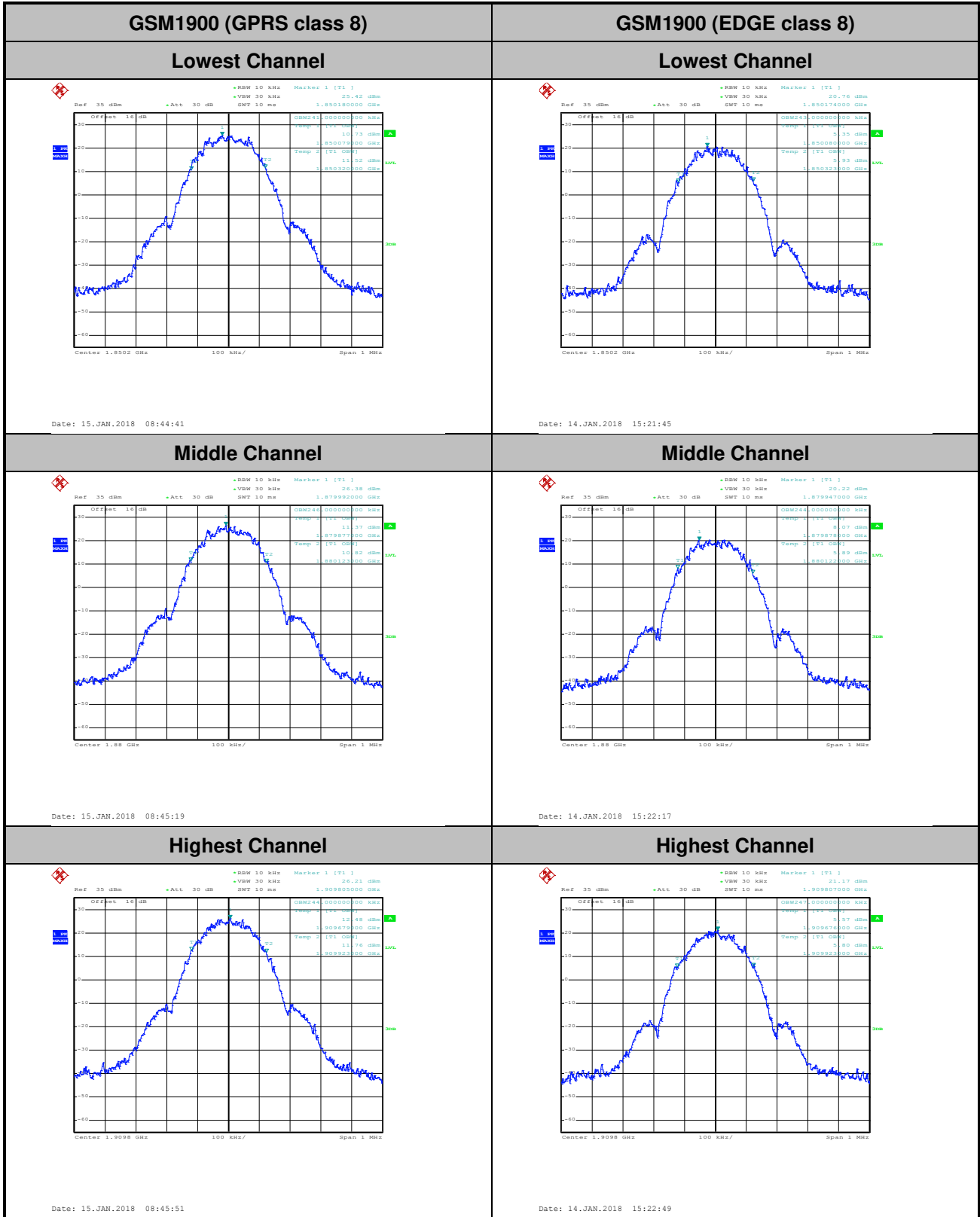



# Conducted Band Edge

## GSM850 (GPRS class 8)

### Lowest Band Edge

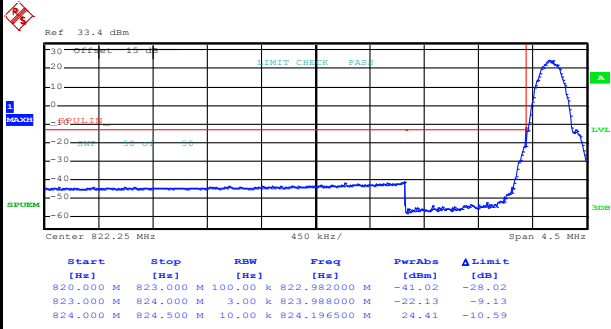

Date: 14.JAN.2018 14:41:40

### Highest Band Edge

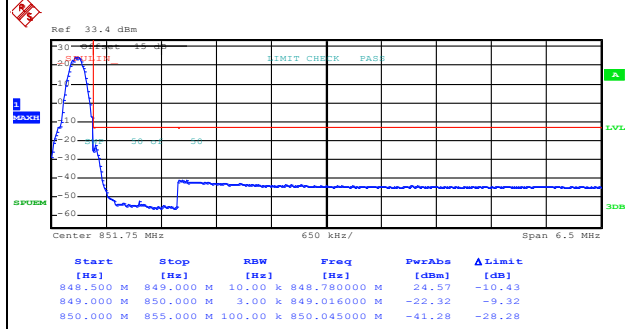

Date: 14.JAN.2018 14:43:11

## GSM850 (EDGE class 8)

### Lowest Band Edge

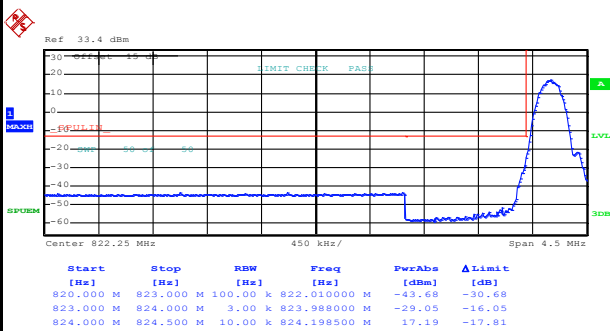

Date: 14.JAN.2018 15:10:04

### Highest Band Edge

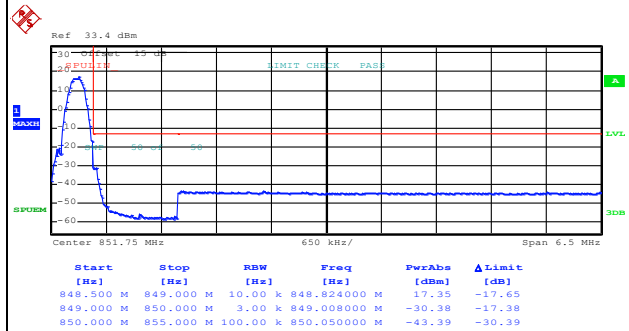

Date: 14.JAN.2018 15:11:36



GSM1900 (GPRS class 8)

Lowest Band Edge

Highest Band Edge

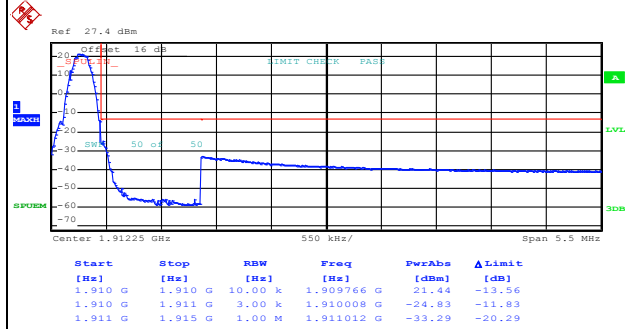
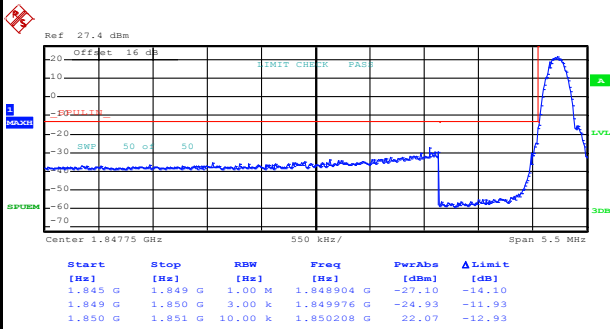

Date: 15.JAN.2018 08:48:02

Date: 15.JAN.2018 08:49:34

GSM1900 (EDGE class 8)

Lowest Band Edge

Highest Band Edge

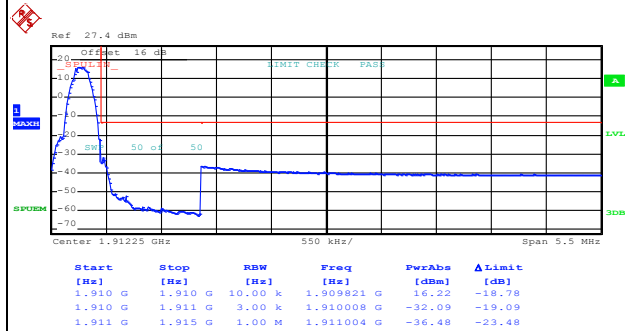
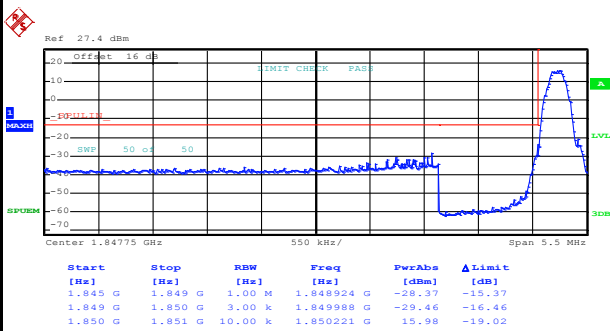

Date: 14.JAN.2018 15:24:22

Date: 14.JAN.2018 15:25:56

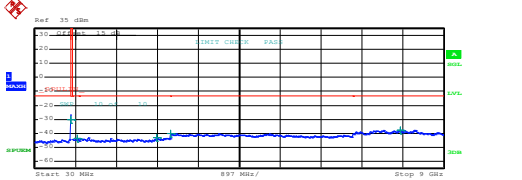
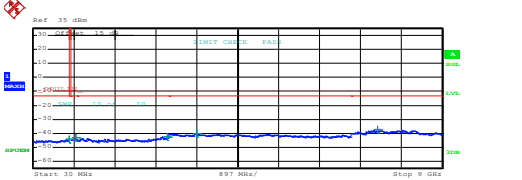
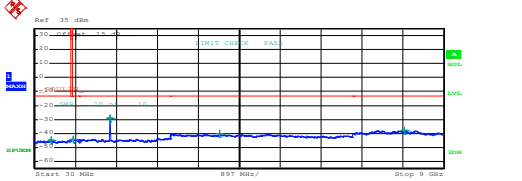
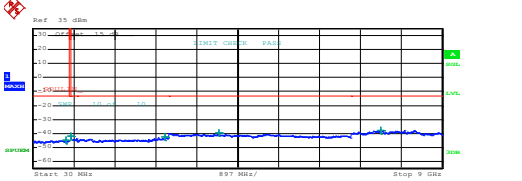
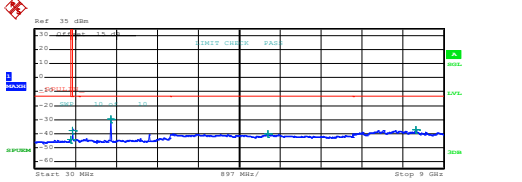
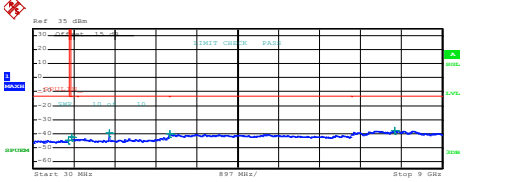

# Conducted Spurious Emission

GSM850 (GPRS class 8)	GSM850 (EDGE class 8)																																																																								
Lowest Channel	Lowest Channel																																																																								
 <table border="1" data-bbox="239 627 699 705"> <thead> <tr> <th>Start [Hz]</th> <th>Stop [Hz]</th> <th>RBW [Hz]</th> <th>Freq [Hz]</th> <th>PwrAbs [dBm]</th> <th>ΔLimit [dB]</th> </tr> </thead> <tbody> <tr> <td>30,000 M</td> <td>820,000 M</td> <td>1,000 M</td> <td>810,000000 M</td> <td>-30.13</td> <td>-17.13</td> </tr> <tr> <td>855,000 M</td> <td>1,000 G</td> <td>1,000 G</td> <td>965,055000 M</td> <td>-43.63</td> <td>-30.63</td> </tr> <tr> <td>1,000 G</td> <td>3,000 G</td> <td>1,000 M</td> <td>2,097000 G</td> <td>-42.99</td> <td>-29.99</td> </tr> <tr> <td>3,000 G</td> <td>7,000 G</td> <td>1,000 M</td> <td>3,003000 G</td> <td>-40.05</td> <td>-27.05</td> </tr> <tr> <td>7,000 G</td> <td>9,000 G</td> <td>1,000 M</td> <td>8,005000 G</td> <td>-37.56</td> <td>-24.56</td> </tr> </tbody> </table> <p>Date: 14.JAN.2018 14:49:16</p>	Start [Hz]	Stop [Hz]	RBW [Hz]	Freq [Hz]	PwrAbs [dBm]	ΔLimit [dB]	30,000 M	820,000 M	1,000 M	810,000000 M	-30.13	-17.13	855,000 M	1,000 G	1,000 G	965,055000 M	-43.63	-30.63	1,000 G	3,000 G	1,000 M	2,097000 G	-42.99	-29.99	3,000 G	7,000 G	1,000 M	3,003000 G	-40.05	-27.05	7,000 G	9,000 G	1,000 M	8,005000 G	-37.56	-24.56	 <table border="1" data-bbox="890 627 1350 705"> <thead> <tr> <th>Start [Hz]</th> <th>Stop [Hz]</th> <th>RBW [Hz]</th> <th>Freq [Hz]</th> <th>PwrAbs [dBm]</th> <th>ΔLimit [dB]</th> </tr> </thead> <tbody> <tr> <td>30,000 M</td> <td>820,000 M</td> <td>1,000 M</td> <td>810,000000 M</td> <td>-44.53</td> <td>-31.53</td> </tr> <tr> <td>855,000 M</td> <td>1,000 G</td> <td>1,000 G</td> <td>971,036250 M</td> <td>-43.33</td> <td>-30.33</td> </tr> <tr> <td>1,000 G</td> <td>3,000 G</td> <td>1,000 M</td> <td>2,979500 G</td> <td>-42.61</td> <td>-29.61</td> </tr> <tr> <td>3,000 G</td> <td>7,000 G</td> <td>1,000 M</td> <td>3,637000 G</td> <td>-40.33</td> <td>-27.33</td> </tr> <tr> <td>7,000 G</td> <td>9,000 G</td> <td>1,000 M</td> <td>7,577000 G</td> <td>-37.49</td> <td>-24.49</td> </tr> </tbody> </table> <p>Date: 14.JAN.2018 15:12:30</p>	Start [Hz]	Stop [Hz]	RBW [Hz]	Freq [Hz]	PwrAbs [dBm]	ΔLimit [dB]	30,000 M	820,000 M	1,000 M	810,000000 M	-44.53	-31.53	855,000 M	1,000 G	1,000 G	971,036250 M	-43.33	-30.33	1,000 G	3,000 G	1,000 M	2,979500 G	-42.61	-29.61	3,000 G	7,000 G	1,000 M	3,637000 G	-40.33	-27.33	7,000 G	9,000 G	1,000 M	7,577000 G	-37.49	-24.49
Start [Hz]	Stop [Hz]	RBW [Hz]	Freq [Hz]	PwrAbs [dBm]	ΔLimit [dB]																																																																				
30,000 M	820,000 M	1,000 M	810,000000 M	-30.13	-17.13																																																																				
855,000 M	1,000 G	1,000 G	965,055000 M	-43.63	-30.63																																																																				
1,000 G	3,000 G	1,000 M	2,097000 G	-42.99	-29.99																																																																				
3,000 G	7,000 G	1,000 M	3,003000 G	-40.05	-27.05																																																																				
7,000 G	9,000 G	1,000 M	8,005000 G	-37.56	-24.56																																																																				
Start [Hz]	Stop [Hz]	RBW [Hz]	Freq [Hz]	PwrAbs [dBm]	ΔLimit [dB]																																																																				
30,000 M	820,000 M	1,000 M	810,000000 M	-44.53	-31.53																																																																				
855,000 M	1,000 G	1,000 G	971,036250 M	-43.33	-30.33																																																																				
1,000 G	3,000 G	1,000 M	2,979500 G	-42.61	-29.61																																																																				
3,000 G	7,000 G	1,000 M	3,637000 G	-40.33	-27.33																																																																				
7,000 G	9,000 G	1,000 M	7,577000 G	-37.49	-24.49																																																																				
Middle Channel	Middle Channel																																																																								
 <table border="1" data-bbox="239 1146 699 1225"> <thead> <tr> <th>Start [Hz]</th> <th>Stop [Hz]</th> <th>RBW [Hz]</th> <th>Freq [Hz]</th> <th>PwrAbs [dBm]</th> <th>ΔLimit [dB]</th> </tr> </thead> <tbody> <tr> <td>30,000 M</td> <td>820,000 M</td> <td>1,000 M</td> <td>394,782500 M</td> <td>-44.96</td> <td>-31.96</td> </tr> <tr> <td>855,000 M</td> <td>1,000 G</td> <td>1,000 M</td> <td>874,828750 M</td> <td>-44.00</td> <td>-31.00</td> </tr> <tr> <td>1,000 G</td> <td>3,000 G</td> <td>1,000 M</td> <td>1,673000 G</td> <td>-29.12</td> <td>-16.12</td> </tr> <tr> <td>3,000 G</td> <td>7,000 G</td> <td>1,000 M</td> <td>4,009000 G</td> <td>-40.13</td> <td>-27.13</td> </tr> <tr> <td>7,000 G</td> <td>9,000 G</td> <td>1,000 M</td> <td>8,143000 G</td> <td>-37.99</td> <td>-24.99</td> </tr> </tbody> </table> <p>Date: 14.JAN.2018 14:50:07</p>	Start [Hz]	Stop [Hz]	RBW [Hz]	Freq [Hz]	PwrAbs [dBm]	ΔLimit [dB]	30,000 M	820,000 M	1,000 M	394,782500 M	-44.96	-31.96	855,000 M	1,000 G	1,000 M	874,828750 M	-44.00	-31.00	1,000 G	3,000 G	1,000 M	1,673000 G	-29.12	-16.12	3,000 G	7,000 G	1,000 M	4,009000 G	-40.13	-27.13	7,000 G	9,000 G	1,000 M	8,143000 G	-37.99	-24.99	 <table border="1" data-bbox="890 1146 1350 1225"> <thead> <tr> <th>Start [Hz]</th> <th>Stop [Hz]</th> <th>RBW [Hz]</th> <th>Freq [Hz]</th> <th>PwrAbs [dBm]</th> <th>ΔLimit [dB]</th> </tr> </thead> <tbody> <tr> <td>30,000 M</td> <td>820,000 M</td> <td>1,000 M</td> <td>740,210000 M</td> <td>-45.09</td> <td>-32.09</td> </tr> <tr> <td>855,000 M</td> <td>1,000 G</td> <td>1,000 M</td> <td>830,398750 M</td> <td>-41.62</td> <td>-28.62</td> </tr> <tr> <td>1,000 G</td> <td>3,000 G</td> <td>1,000 M</td> <td>2,937500 G</td> <td>-42.53</td> <td>-29.53</td> </tr> <tr> <td>3,000 G</td> <td>7,000 G</td> <td>1,000 M</td> <td>4,094000 G</td> <td>-39.82</td> <td>-26.82</td> </tr> <tr> <td>7,000 G</td> <td>9,000 G</td> <td>1,000 M</td> <td>7,637500 G</td> <td>-37.73</td> <td>-24.73</td> </tr> </tbody> </table> <p>Date: 14.JAN.2018 15:13:20</p>	Start [Hz]	Stop [Hz]	RBW [Hz]	Freq [Hz]	PwrAbs [dBm]	ΔLimit [dB]	30,000 M	820,000 M	1,000 M	740,210000 M	-45.09	-32.09	855,000 M	1,000 G	1,000 M	830,398750 M	-41.62	-28.62	1,000 G	3,000 G	1,000 M	2,937500 G	-42.53	-29.53	3,000 G	7,000 G	1,000 M	4,094000 G	-39.82	-26.82	7,000 G	9,000 G	1,000 M	7,637500 G	-37.73	-24.73
Start [Hz]	Stop [Hz]	RBW [Hz]	Freq [Hz]	PwrAbs [dBm]	ΔLimit [dB]																																																																				
30,000 M	820,000 M	1,000 M	394,782500 M	-44.96	-31.96																																																																				
855,000 M	1,000 G	1,000 M	874,828750 M	-44.00	-31.00																																																																				
1,000 G	3,000 G	1,000 M	1,673000 G	-29.12	-16.12																																																																				
3,000 G	7,000 G	1,000 M	4,009000 G	-40.13	-27.13																																																																				
7,000 G	9,000 G	1,000 M	8,143000 G	-37.99	-24.99																																																																				
Start [Hz]	Stop [Hz]	RBW [Hz]	Freq [Hz]	PwrAbs [dBm]	ΔLimit [dB]																																																																				
30,000 M	820,000 M	1,000 M	740,210000 M	-45.09	-32.09																																																																				
855,000 M	1,000 G	1,000 M	830,398750 M	-41.62	-28.62																																																																				
1,000 G	3,000 G	1,000 M	2,937500 G	-42.53	-29.53																																																																				
3,000 G	7,000 G	1,000 M	4,094000 G	-39.82	-26.82																																																																				
7,000 G	9,000 G	1,000 M	7,637500 G	-37.73	-24.73																																																																				
Highest Channel	Highest Channel																																																																								
 <table border="1" data-bbox="239 1666 699 1744"> <thead> <tr> <th>Start [Hz]</th> <th>Stop [Hz]</th> <th>RBW [Hz]</th> <th>Freq [Hz]</th> <th>PwrAbs [dBm]</th> <th>ΔLimit [dB]</th> </tr> </thead> <tbody> <tr> <td>30,000 M</td> <td>820,000 M</td> <td>1,000 M</td> <td>810,000000 M</td> <td>-44.92</td> <td>-31.92</td> </tr> <tr> <td>855,000 M</td> <td>1,000 G</td> <td>1,000 G</td> <td>855,036250 M</td> <td>-37.94</td> <td>-24.94</td> </tr> <tr> <td>1,000 G</td> <td>3,000 G</td> <td>1,000 M</td> <td>1,698000 G</td> <td>-29.39</td> <td>-16.39</td> </tr> <tr> <td>3,000 G</td> <td>7,000 G</td> <td>1,000 M</td> <td>3,143000 G</td> <td>-40.19</td> <td>-27.19</td> </tr> <tr> <td>7,000 G</td> <td>9,000 G</td> <td>1,000 M</td> <td>8,389500 G</td> <td>-37.51</td> <td>-24.51</td> </tr> </tbody> </table> <p>Date: 14.JAN.2018 14:50:58</p>	Start [Hz]	Stop [Hz]	RBW [Hz]	Freq [Hz]	PwrAbs [dBm]	ΔLimit [dB]	30,000 M	820,000 M	1,000 M	810,000000 M	-44.92	-31.92	855,000 M	1,000 G	1,000 G	855,036250 M	-37.94	-24.94	1,000 G	3,000 G	1,000 M	1,698000 G	-29.39	-16.39	3,000 G	7,000 G	1,000 M	3,143000 G	-40.19	-27.19	7,000 G	9,000 G	1,000 M	8,389500 G	-37.51	-24.51	 <table border="1" data-bbox="890 1666 1350 1744"> <thead> <tr> <th>Start [Hz]</th> <th>Stop [Hz]</th> <th>RBW [Hz]</th> <th>Freq [Hz]</th> <th>PwrAbs [dBm]</th> <th>ΔLimit [dB]</th> </tr> </thead> <tbody> <tr> <td>30,000 M</td> <td>820,000 M</td> <td>1,000 M</td> <td>794,720000 M</td> <td>-44.80</td> <td>-31.80</td> </tr> <tr> <td>855,000 M</td> <td>1,000 G</td> <td>1,000 M</td> <td>868,013750 M</td> <td>-42.35</td> <td>-29.35</td> </tr> <tr> <td>1,000 G</td> <td>3,000 G</td> <td>1,000 M</td> <td>1,698000 G</td> <td>-39.33</td> <td>-26.33</td> </tr> <tr> <td>3,000 G</td> <td>7,000 G</td> <td>1,000 M</td> <td>3,039000 G</td> <td>-40.40</td> <td>-27.40</td> </tr> <tr> <td>7,000 G</td> <td>9,000 G</td> <td>1,000 M</td> <td>7,953500 G</td> <td>-37.98</td> <td>-24.98</td> </tr> </tbody> </table> <p>Date: 14.JAN.2018 15:14:10</p>	Start [Hz]	Stop [Hz]	RBW [Hz]	Freq [Hz]	PwrAbs [dBm]	ΔLimit [dB]	30,000 M	820,000 M	1,000 M	794,720000 M	-44.80	-31.80	855,000 M	1,000 G	1,000 M	868,013750 M	-42.35	-29.35	1,000 G	3,000 G	1,000 M	1,698000 G	-39.33	-26.33	3,000 G	7,000 G	1,000 M	3,039000 G	-40.40	-27.40	7,000 G	9,000 G	1,000 M	7,953500 G	-37.98	-24.98
Start [Hz]	Stop [Hz]	RBW [Hz]	Freq [Hz]	PwrAbs [dBm]	ΔLimit [dB]																																																																				
30,000 M	820,000 M	1,000 M	810,000000 M	-44.92	-31.92																																																																				
855,000 M	1,000 G	1,000 G	855,036250 M	-37.94	-24.94																																																																				
1,000 G	3,000 G	1,000 M	1,698000 G	-29.39	-16.39																																																																				
3,000 G	7,000 G	1,000 M	3,143000 G	-40.19	-27.19																																																																				
7,000 G	9,000 G	1,000 M	8,389500 G	-37.51	-24.51																																																																				
Start [Hz]	Stop [Hz]	RBW [Hz]	Freq [Hz]	PwrAbs [dBm]	ΔLimit [dB]																																																																				
30,000 M	820,000 M	1,000 M	794,720000 M	-44.80	-31.80																																																																				
855,000 M	1,000 G	1,000 M	868,013750 M	-42.35	-29.35																																																																				
1,000 G	3,000 G	1,000 M	1,698000 G	-39.33	-26.33																																																																				
3,000 G	7,000 G	1,000 M	3,039000 G	-40.40	-27.40																																																																				
7,000 G	9,000 G	1,000 M	7,953500 G	-37.98	-24.98																																																																				

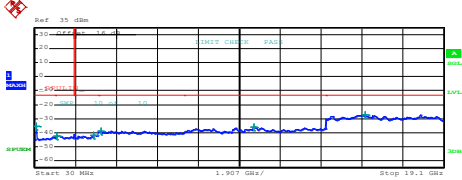
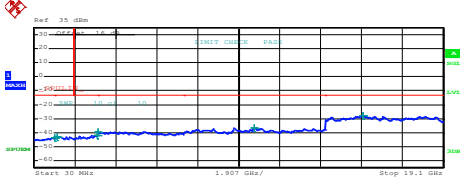
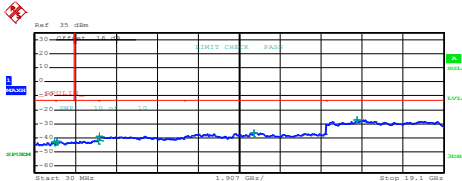
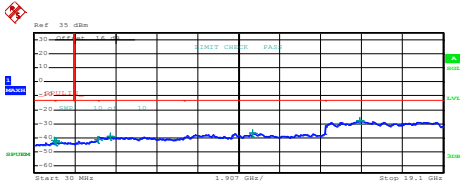
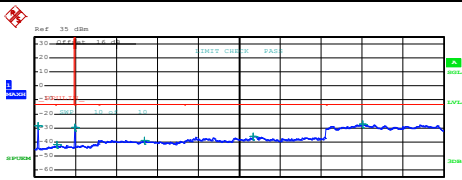
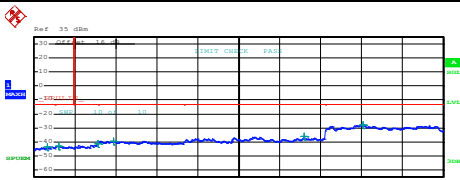

GSM1900 (GPRS class 8)	GSM1900 (EDGE class 8)																																																																																				
Lowest Channel	Lowest Channel																																																																																				
 <table border="1" data-bbox="239 571 638 672"> <thead> <tr> <th>Start [MHz]</th> <th>Stop [MHz]</th> <th>RBW [Hz]</th> <th>Freq [MHz]</th> <th>PwrAve [dBm]</th> <th>ΔLimit [dB]</th> </tr> </thead> <tbody> <tr><td>30.0000</td><td>1.0000</td><td>1.000</td><td>111.965000</td><td>-35.55</td><td>-22.55</td></tr> <tr><td>1.0000</td><td>1.8450</td><td>1.000</td><td>1.062108</td><td>-42.27</td><td>-29.27</td></tr> <tr><td>1.8450</td><td>3.0000</td><td>1.000</td><td>2.772692</td><td>-42.80</td><td>-28.80</td></tr> <tr><td>3.0000</td><td>7.0000</td><td>1.000</td><td>3.130000</td><td>-38.88</td><td>-25.88</td></tr> <tr><td>7.0000</td><td>13.6000</td><td>1.000</td><td>10.243975</td><td>-36.04</td><td>-23.04</td></tr> <tr><td>13.6000</td><td>19.1000</td><td>1.000</td><td>15.439750</td><td>-27.19</td><td>-14.19</td></tr> </tbody> </table> <p>Date: 15.JAN.2018 08:50:36</p>	Start [MHz]	Stop [MHz]	RBW [Hz]	Freq [MHz]	PwrAve [dBm]	ΔLimit [dB]	30.0000	1.0000	1.000	111.965000	-35.55	-22.55	1.0000	1.8450	1.000	1.062108	-42.27	-29.27	1.8450	3.0000	1.000	2.772692	-42.80	-28.80	3.0000	7.0000	1.000	3.130000	-38.88	-25.88	7.0000	13.6000	1.000	10.243975	-36.04	-23.04	13.6000	19.1000	1.000	15.439750	-27.19	-14.19	 <table border="1" data-bbox="888 571 1287 672"> <thead> <tr> <th>Start [MHz]</th> <th>Stop [MHz]</th> <th>RBW [Hz]</th> <th>Freq [MHz]</th> <th>PwrAve [dBm]</th> <th>ΔLimit [dB]</th> </tr> </thead> <tbody> <tr><td>30.0000</td><td>1.0000</td><td>1.000</td><td>978.921500</td><td>-43.51</td><td>-30.51</td></tr> <tr><td>1.0000</td><td>1.8450</td><td>1.000</td><td>1.096330</td><td>-42.79</td><td>-29.79</td></tr> <tr><td>1.8450</td><td>3.0000</td><td>1.000</td><td>2.988335</td><td>-42.04</td><td>-29.04</td></tr> <tr><td>3.0000</td><td>7.0000</td><td>1.000</td><td>3.007000</td><td>-39.41</td><td>-26.41</td></tr> <tr><td>7.0000</td><td>13.6000</td><td>1.000</td><td>10.271950</td><td>-36.72</td><td>-23.72</td></tr> <tr><td>13.6000</td><td>19.1000</td><td>1.000</td><td>15.374438</td><td>-27.92</td><td>-14.92</td></tr> </tbody> </table> <p>Date: 14.JAN.2018 15:28:36</p>	Start [MHz]	Stop [MHz]	RBW [Hz]	Freq [MHz]	PwrAve [dBm]	ΔLimit [dB]	30.0000	1.0000	1.000	978.921500	-43.51	-30.51	1.0000	1.8450	1.000	1.096330	-42.79	-29.79	1.8450	3.0000	1.000	2.988335	-42.04	-29.04	3.0000	7.0000	1.000	3.007000	-39.41	-26.41	7.0000	13.6000	1.000	10.271950	-36.72	-23.72	13.6000	19.1000	1.000	15.374438	-27.92	-14.92
Start [MHz]	Stop [MHz]	RBW [Hz]	Freq [MHz]	PwrAve [dBm]	ΔLimit [dB]																																																																																
30.0000	1.0000	1.000	111.965000	-35.55	-22.55																																																																																
1.0000	1.8450	1.000	1.062108	-42.27	-29.27																																																																																
1.8450	3.0000	1.000	2.772692	-42.80	-28.80																																																																																
3.0000	7.0000	1.000	3.130000	-38.88	-25.88																																																																																
7.0000	13.6000	1.000	10.243975	-36.04	-23.04																																																																																
13.6000	19.1000	1.000	15.439750	-27.19	-14.19																																																																																
Start [MHz]	Stop [MHz]	RBW [Hz]	Freq [MHz]	PwrAve [dBm]	ΔLimit [dB]																																																																																
30.0000	1.0000	1.000	978.921500	-43.51	-30.51																																																																																
1.0000	1.8450	1.000	1.096330	-42.79	-29.79																																																																																
1.8450	3.0000	1.000	2.988335	-42.04	-29.04																																																																																
3.0000	7.0000	1.000	3.007000	-39.41	-26.41																																																																																
7.0000	13.6000	1.000	10.271950	-36.72	-23.72																																																																																
13.6000	19.1000	1.000	15.374438	-27.92	-14.92																																																																																
Middle Channel	Middle Channel																																																																																				
 <table border="1" data-bbox="239 1086 638 1187"> <thead> <tr> <th>Start [MHz]</th> <th>Stop [MHz]</th> <th>RBW [Hz]</th> <th>Freq [MHz]</th> <th>PwrAve [dBm]</th> <th>ΔLimit [dB]</th> </tr> </thead> <tbody> <tr><td>30.0000</td><td>1.0000</td><td>1.000</td><td>956.835000</td><td>-43.04</td><td>-30.04</td></tr> <tr><td>1.0000</td><td>1.8450</td><td>1.000</td><td>1.002178</td><td>-42.34</td><td>-29.34</td></tr> <tr><td>1.8450</td><td>3.0000</td><td>1.000</td><td>2.989729</td><td>-41.83</td><td>-28.83</td></tr> <tr><td>3.0000</td><td>7.0000</td><td>1.000</td><td>3.034000</td><td>-38.90</td><td>-25.90</td></tr> <tr><td>7.0000</td><td>13.6000</td><td>1.000</td><td>10.238825</td><td>-36.44</td><td>-23.44</td></tr> <tr><td>13.6000</td><td>19.1000</td><td>1.000</td><td>15.052000</td><td>-27.36</td><td>-14.36</td></tr> </tbody> </table> <p>Date: 15.JAN.2018 08:51:27</p>	Start [MHz]	Stop [MHz]	RBW [Hz]	Freq [MHz]	PwrAve [dBm]	ΔLimit [dB]	30.0000	1.0000	1.000	956.835000	-43.04	-30.04	1.0000	1.8450	1.000	1.002178	-42.34	-29.34	1.8450	3.0000	1.000	2.989729	-41.83	-28.83	3.0000	7.0000	1.000	3.034000	-38.90	-25.90	7.0000	13.6000	1.000	10.238825	-36.44	-23.44	13.6000	19.1000	1.000	15.052000	-27.36	-14.36	 <table border="1" data-bbox="888 1086 1287 1187"> <thead> <tr> <th>Start [MHz]</th> <th>Stop [MHz]</th> <th>RBW [Hz]</th> <th>Freq [MHz]</th> <th>PwrAve [dBm]</th> <th>ΔLimit [dB]</th> </tr> </thead> <tbody> <tr><td>30.0000</td><td>1.0000</td><td>1.000</td><td>993.695000</td><td>-42.13</td><td>-29.13</td></tr> <tr><td>1.0000</td><td>1.8450</td><td>1.000</td><td>1.048861</td><td>-43.22</td><td>-30.22</td></tr> <tr><td>1.8450</td><td>3.0000</td><td>1.000</td><td>2.998915</td><td>-41.55</td><td>-28.55</td></tr> <tr><td>3.0000</td><td>7.0000</td><td>1.000</td><td>3.582000</td><td>-39.08</td><td>-26.08</td></tr> <tr><td>7.0000</td><td>13.6000</td><td>1.000</td><td>10.231525</td><td>-36.87</td><td>-23.87</td></tr> <tr><td>13.6000</td><td>19.1000</td><td>1.000</td><td>15.228687</td><td>-27.88</td><td>-14.88</td></tr> </tbody> </table> <p>Date: 14.JAN.2018 15:30:15</p>	Start [MHz]	Stop [MHz]	RBW [Hz]	Freq [MHz]	PwrAve [dBm]	ΔLimit [dB]	30.0000	1.0000	1.000	993.695000	-42.13	-29.13	1.0000	1.8450	1.000	1.048861	-43.22	-30.22	1.8450	3.0000	1.000	2.998915	-41.55	-28.55	3.0000	7.0000	1.000	3.582000	-39.08	-26.08	7.0000	13.6000	1.000	10.231525	-36.87	-23.87	13.6000	19.1000	1.000	15.228687	-27.88	-14.88
Start [MHz]	Stop [MHz]	RBW [Hz]	Freq [MHz]	PwrAve [dBm]	ΔLimit [dB]																																																																																
30.0000	1.0000	1.000	956.835000	-43.04	-30.04																																																																																
1.0000	1.8450	1.000	1.002178	-42.34	-29.34																																																																																
1.8450	3.0000	1.000	2.989729	-41.83	-28.83																																																																																
3.0000	7.0000	1.000	3.034000	-38.90	-25.90																																																																																
7.0000	13.6000	1.000	10.238825	-36.44	-23.44																																																																																
13.6000	19.1000	1.000	15.052000	-27.36	-14.36																																																																																
Start [MHz]	Stop [MHz]	RBW [Hz]	Freq [MHz]	PwrAve [dBm]	ΔLimit [dB]																																																																																
30.0000	1.0000	1.000	993.695000	-42.13	-29.13																																																																																
1.0000	1.8450	1.000	1.048861	-43.22	-30.22																																																																																
1.8450	3.0000	1.000	2.998915	-41.55	-28.55																																																																																
3.0000	7.0000	1.000	3.582000	-39.08	-26.08																																																																																
7.0000	13.6000	1.000	10.231525	-36.87	-23.87																																																																																
13.6000	19.1000	1.000	15.228687	-27.88	-14.88																																																																																
Highest Channel	Highest Channel																																																																																				
 <table border="1" data-bbox="239 1601 638 1702"> <thead> <tr> <th>Start [MHz]</th> <th>Stop [MHz]</th> <th>RBW [Hz]</th> <th>Freq [MHz]</th> <th>PwrAve [dBm]</th> <th>ΔLimit [dB]</th> </tr> </thead> <tbody> <tr><td>30.0000</td><td>1.0000</td><td>1.000</td><td>171.600000</td><td>-28.59</td><td>-15.59</td></tr> <tr><td>1.0000</td><td>1.8450</td><td>1.000</td><td>1.064009</td><td>-42.12</td><td>-29.12</td></tr> <tr><td>1.8450</td><td>3.0000</td><td>1.000</td><td>1.932071</td><td>-39.37</td><td>-26.37</td></tr> <tr><td>3.0000</td><td>7.0000</td><td>1.000</td><td>3.130000</td><td>-39.05</td><td>-26.05</td></tr> <tr><td>7.0000</td><td>13.6000</td><td>1.000</td><td>10.208425</td><td>-36.15</td><td>-23.15</td></tr> <tr><td>13.6000</td><td>19.1000</td><td>1.000</td><td>15.324250</td><td>-27.12</td><td>-14.12</td></tr> </tbody> </table> <p>Date: 15.JAN.2018 08:52:18</p>	Start [MHz]	Stop [MHz]	RBW [Hz]	Freq [MHz]	PwrAve [dBm]	ΔLimit [dB]	30.0000	1.0000	1.000	171.600000	-28.59	-15.59	1.0000	1.8450	1.000	1.064009	-42.12	-29.12	1.8450	3.0000	1.000	1.932071	-39.37	-26.37	3.0000	7.0000	1.000	3.130000	-39.05	-26.05	7.0000	13.6000	1.000	10.208425	-36.15	-23.15	13.6000	19.1000	1.000	15.324250	-27.12	-14.12	 <table border="1" data-bbox="888 1601 1287 1702"> <thead> <tr> <th>Start [MHz]</th> <th>Stop [MHz]</th> <th>RBW [Hz]</th> <th>Freq [MHz]</th> <th>PwrAve [dBm]</th> <th>ΔLimit [dB]</th> </tr> </thead> <tbody> <tr><td>30.0000</td><td>1.0000</td><td>1.000</td><td>622.421500</td><td>-43.72</td><td>-30.72</td></tr> <tr><td>1.0000</td><td>1.8450</td><td>1.000</td><td>1.178718</td><td>-42.96</td><td>-29.96</td></tr> <tr><td>1.8450</td><td>3.0000</td><td>1.000</td><td>2.986438</td><td>-41.17</td><td>-28.17</td></tr> <tr><td>3.0000</td><td>7.0000</td><td>1.000</td><td>3.747000</td><td>-39.59</td><td>-26.59</td></tr> <tr><td>7.0000</td><td>13.6000</td><td>1.000</td><td>12.609175</td><td>-36.25</td><td>-23.25</td></tr> <tr><td>13.6000</td><td>19.1000</td><td>1.000</td><td>15.375125</td><td>-28.12</td><td>-15.12</td></tr> </tbody> </table> <p>Date: 14.JAN.2018 15:31:05</p>	Start [MHz]	Stop [MHz]	RBW [Hz]	Freq [MHz]	PwrAve [dBm]	ΔLimit [dB]	30.0000	1.0000	1.000	622.421500	-43.72	-30.72	1.0000	1.8450	1.000	1.178718	-42.96	-29.96	1.8450	3.0000	1.000	2.986438	-41.17	-28.17	3.0000	7.0000	1.000	3.747000	-39.59	-26.59	7.0000	13.6000	1.000	12.609175	-36.25	-23.25	13.6000	19.1000	1.000	15.375125	-28.12	-15.12
Start [MHz]	Stop [MHz]	RBW [Hz]	Freq [MHz]	PwrAve [dBm]	ΔLimit [dB]																																																																																
30.0000	1.0000	1.000	171.600000	-28.59	-15.59																																																																																
1.0000	1.8450	1.000	1.064009	-42.12	-29.12																																																																																
1.8450	3.0000	1.000	1.932071	-39.37	-26.37																																																																																
3.0000	7.0000	1.000	3.130000	-39.05	-26.05																																																																																
7.0000	13.6000	1.000	10.208425	-36.15	-23.15																																																																																
13.6000	19.1000	1.000	15.324250	-27.12	-14.12																																																																																
Start [MHz]	Stop [MHz]	RBW [Hz]	Freq [MHz]	PwrAve [dBm]	ΔLimit [dB]																																																																																
30.0000	1.0000	1.000	622.421500	-43.72	-30.72																																																																																
1.0000	1.8450	1.000	1.178718	-42.96	-29.96																																																																																
1.8450	3.0000	1.000	2.986438	-41.17	-28.17																																																																																
3.0000	7.0000	1.000	3.747000	-39.59	-26.59																																																																																
7.0000	13.6000	1.000	12.609175	-36.25	-23.25																																																																																
13.6000	19.1000	1.000	15.375125	-28.12	-15.12																																																																																



### Frequency Stability

Test Conditions	Middle Channel	GSM850 (GPRS class 8)	GSM850 (EDGE class 8)	Limit 2.5ppm
Temperature (°C)	Voltage (Volt)	Deviation (ppm)		Result
50	Normal Voltage	0.0024	0.0024	PASS
40	Normal Voltage	0.0048	0.0036	
30	Normal Voltage	0.0060	0.0084	
20(Ref.)	Normal Voltage	0.0000	0.0000	
10	Normal Voltage	0.0084	0.0084	
0	Normal Voltage	0.0036	0.0108	
-10	Normal Voltage	0.0000	0.0084	
-20	Normal Voltage	0.0048	0.0108	
-30	Normal Voltage	0.0036	0.0143	
20	Maximum Voltage	0.0024	0.0096	
20	Normal Voltage	0.0000	0.0000	
20	Battery End Point	0.0024	0.0120	



Test Conditions	Middle Channel	GSM1900 (GPRS class 8)	GSM1900 (EDGE class 8)	Limit Note 2.
Temperature (°C)	Voltage (Volt)	Deviation (ppm)		Result
50	Normal Voltage	0.0027	0.0048	PASS
40	Normal Voltage	0.0106	0.0016	
30	Normal Voltage	0.0011	0.0011	
20(Ref.)	Normal Voltage	0.0000	0.0000	
10	Normal Voltage	0.0005	0.0011	
0	Normal Voltage	0.0048	0.0021	
-10	Normal Voltage	0.0122	0.0043	
-20	Normal Voltage	0.0080	0.0048	
-30	Normal Voltage	0.0090	0.0027	
20	Maximum Voltage	0.0117	0.0053	
20	Normal Voltage	0.0000	0.0000	
20	Battery End Point	0.0122	0.0059	

**Note:**

1. Normal Voltage = 3.8 V. ; Battery End Point (BEP) = 3.5 V. ; Maximum Voltage =4.4 V
2. The frequency fundamental emissions stay within the authorized frequency block .



### A3. WCDMA

#### Peak-to-Average Ratio

Mode	WCDMA Band V	WCDMA Band II	WCDMA Band IV	Limit: 13dB
Mod.	RMC 12.2Kbps	RMC 12.2Kbps	RMC 12.2Kbps	Result
Lowest CH	3.16	2.92	2.96	PASS
Middle CH	3.20	3.00	2.92	
Highest CH	3.24	2.96	3.00	



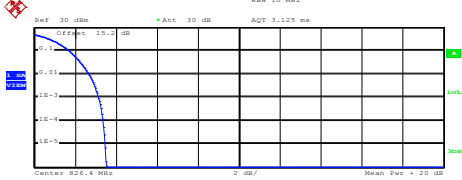
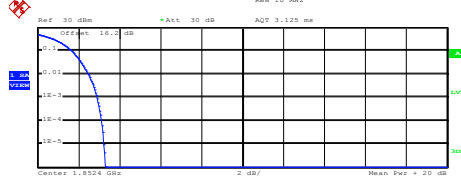
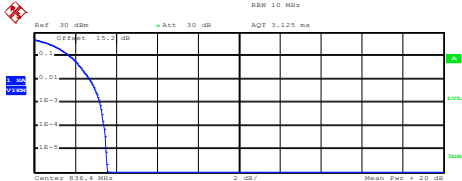
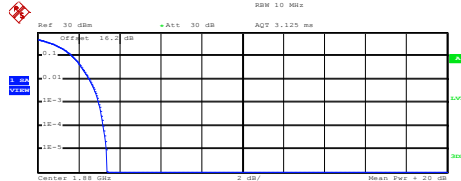
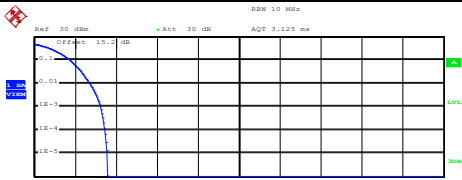
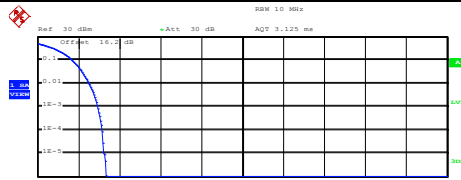

WCDMA Band V (RMC 12.2Kbps)	WCDMA Band II (RMC 12.2Kbps)																
<p align="center"><b>Lowest Channel</b></p>  <p>Center 826.4 MHz      2 dB/      Mean Pwr + 20 dB</p> <p>Complementary Cumulative Distribution Function (100000 samples) Trace 1 Mean 21.55 dBm Peak 25.07 dBm Crest 3.53 dB</p> <table border="0"> <tr><td>10 %</td><td>1.72 dB</td></tr> <tr><td>1 %</td><td>2.68 dB</td></tr> <tr><td>.1 %</td><td>3.16 dB</td></tr> <tr><td>.01 %</td><td>3.36 dB</td></tr> </table> <p>Date: 14.JAN.2018 14:28:44</p>	10 %	1.72 dB	1 %	2.68 dB	.1 %	3.16 dB	.01 %	3.36 dB	<p align="center"><b>Lowest Channel</b></p>  <p>Center 1.8524 GHz      2 dB/      Mean Pwr + 20 dB</p> <p>Complementary Cumulative Distribution Function (100000 samples) Trace 1 Mean 21.63 dBm Peak 24.93 dBm Crest 3.30 dB</p> <table border="0"> <tr><td>10 %</td><td>1.68 dB</td></tr> <tr><td>1 %</td><td>2.48 dB</td></tr> <tr><td>.1 %</td><td>2.92 dB</td></tr> <tr><td>.01 %</td><td>3.12 dB</td></tr> </table> <p>Date: 14.JAN.2018 13:58:17</p>	10 %	1.68 dB	1 %	2.48 dB	.1 %	2.92 dB	.01 %	3.12 dB
10 %	1.72 dB																
1 %	2.68 dB																
.1 %	3.16 dB																
.01 %	3.36 dB																
10 %	1.68 dB																
1 %	2.48 dB																
.1 %	2.92 dB																
.01 %	3.12 dB																
<p align="center"><b>Middle Channel</b></p>  <p>Center 830.4 MHz      2 dB/      Mean Pwr + 20 dB</p> <p>Complementary Cumulative Distribution Function (100000 samples) Trace 1 Mean 21.43 dBm Peak 25.00 dBm Crest 3.57 dB</p> <table border="0"> <tr><td>10 %</td><td>1.72 dB</td></tr> <tr><td>1 %</td><td>2.72 dB</td></tr> <tr><td>.1 %</td><td>3.20 dB</td></tr> <tr><td>.01 %</td><td>3.40 dB</td></tr> </table> <p>Date: 14.JAN.2018 14:28:59</p>	10 %	1.72 dB	1 %	2.72 dB	.1 %	3.20 dB	.01 %	3.40 dB	<p align="center"><b>Middle Channel</b></p>  <p>Center 1.88 GHz      2 dB/      Mean Pwr + 20 dB</p> <p>Complementary Cumulative Distribution Function (100000 samples) Trace 1 Mean 21.82 dBm Peak 25.21 dBm Crest 3.39 dB</p> <table border="0"> <tr><td>10 %</td><td>1.68 dB</td></tr> <tr><td>1 %</td><td>2.52 dB</td></tr> <tr><td>.1 %</td><td>3.00 dB</td></tr> <tr><td>.01 %</td><td>3.20 dB</td></tr> </table> <p>Date: 14.JAN.2018 13:58:39</p>	10 %	1.68 dB	1 %	2.52 dB	.1 %	3.00 dB	.01 %	3.20 dB
10 %	1.72 dB																
1 %	2.72 dB																
.1 %	3.20 dB																
.01 %	3.40 dB																
10 %	1.68 dB																
1 %	2.52 dB																
.1 %	3.00 dB																
.01 %	3.20 dB																
<p align="center"><b>Highest Channel</b></p>  <p>Center 846.6 MHz      2 dB/      Mean Pwr + 20 dB</p> <p>Complementary Cumulative Distribution Function (100000 samples) Trace 1 Mean 21.42 dBm Peak 25.00 dBm Crest 3.59 dB</p> <table border="0"> <tr><td>10 %</td><td>1.76 dB</td></tr> <tr><td>1 %</td><td>2.72 dB</td></tr> <tr><td>.1 %</td><td>3.24 dB</td></tr> <tr><td>.01 %</td><td>3.44 dB</td></tr> </table> <p>Date: 14.JAN.2018 14:29:17</p>	10 %	1.76 dB	1 %	2.72 dB	.1 %	3.24 dB	.01 %	3.44 dB	<p align="center"><b>Highest Channel</b></p>  <p>Center 1.9076 GHz      2 dB/      Mean Pwr + 20 dB</p> <p>Complementary Cumulative Distribution Function (100000 samples) Trace 1 Mean 21.73 dBm Peak 25.07 dBm Crest 3.35 dB</p> <table border="0"> <tr><td>10 %</td><td>1.68 dB</td></tr> <tr><td>1 %</td><td>2.52 dB</td></tr> <tr><td>.1 %</td><td>2.96 dB</td></tr> <tr><td>.01 %</td><td>3.16 dB</td></tr> </table> <p>Date: 14.JAN.2018 13:58:55</p>	10 %	1.68 dB	1 %	2.52 dB	.1 %	2.96 dB	.01 %	3.16 dB
10 %	1.76 dB																
1 %	2.72 dB																
.1 %	3.24 dB																
.01 %	3.44 dB																
10 %	1.68 dB																
1 %	2.52 dB																
.1 %	2.96 dB																
.01 %	3.16 dB																



WCDMA Band IV (RMC 12.2Kbps)

Lowest Channel

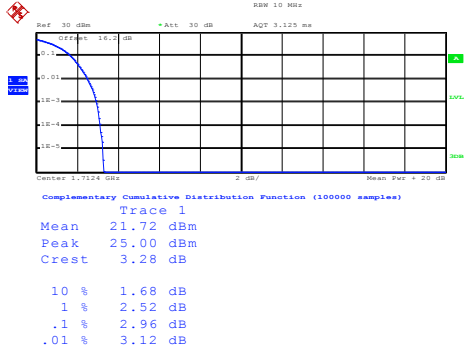

Date: 14.JAN.2018 14:14:26

Middle Channel

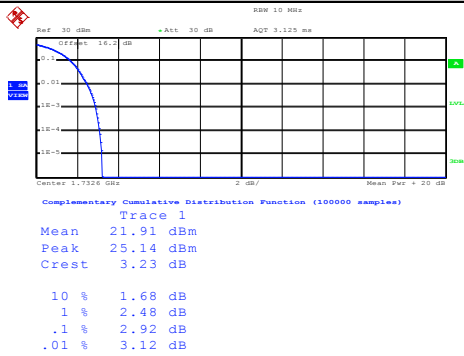

Date: 14.JAN.2018 14:14:42

Highest Channel

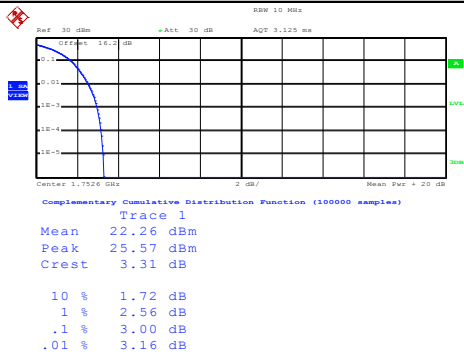

Date: 14.JAN.2018 14:14:57



**26dB Bandwidth**

Mode	WCDMA Band V	WCDMA Band II	WCDMA Band IV
Mod.	RMC 12.2Kbps	RMC 12.2Kbps	RMC 12.2Kbps
Lowest CH	4.70	4.72	4.72
Middle CH	4.70	4.74	4.72
Highest CH	4.70	4.72	4.71



WCDMA Band V (RMC 12.2Kbps)

Lowest Channel

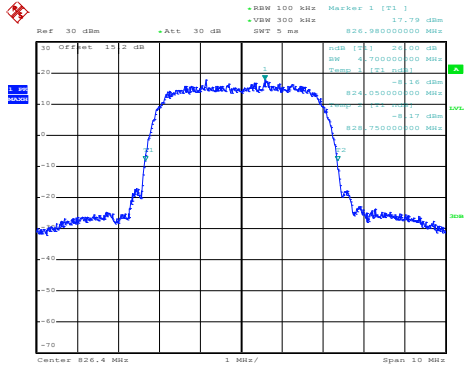

Date: 14.JAN.2018 14:16:17

WCDMA Band II (RMC 12.2Kbps)

Lowest Channel

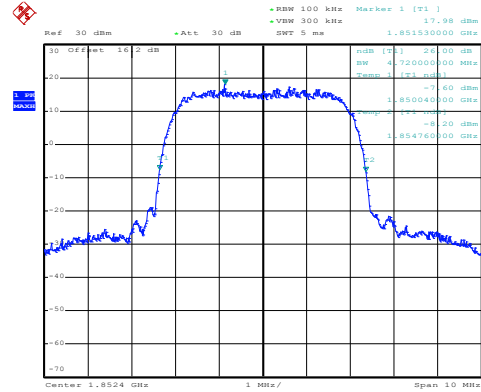

Date: 14.JAN.2018 13:44:01

Middle Channel

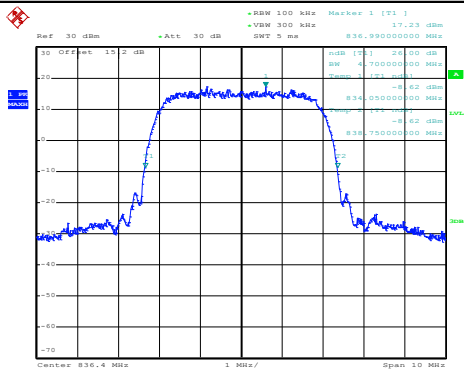

Date: 14.JAN.2018 14:17:04

Middle Channel

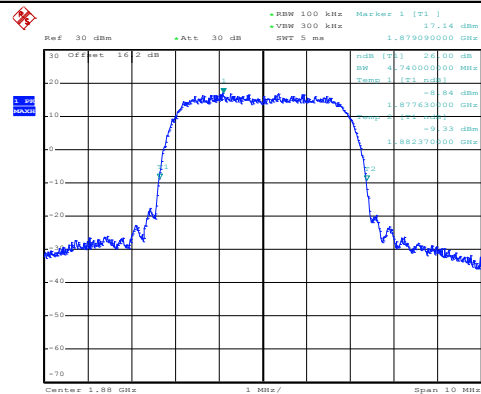

Date: 14.JAN.2018 13:44:44

Highest Channel

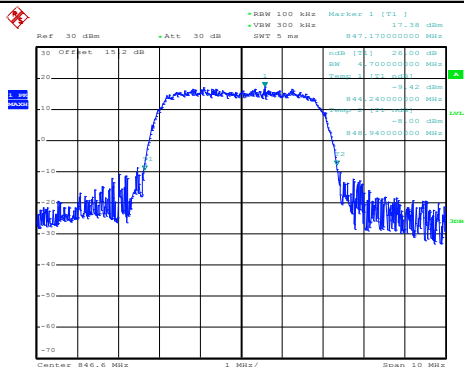

Date: 14.JAN.2018 14:17:38

Highest Channel

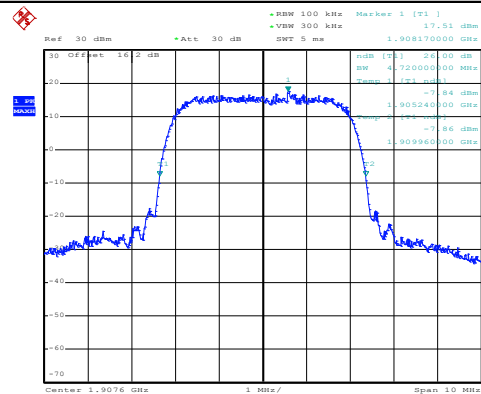

Date: 14.JAN.2018 13:46:11



WCDMA Band IV (RMC 12.2Kbps)

Lowest Channel

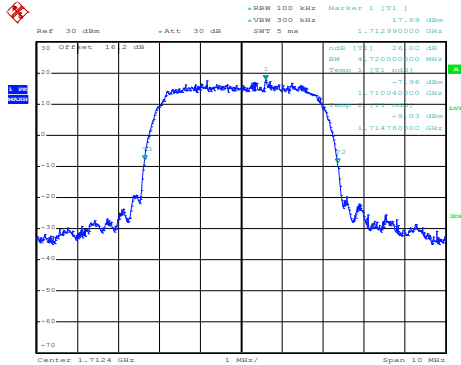

Date: 14.JAN.2018 14:00:21

Middle Channel

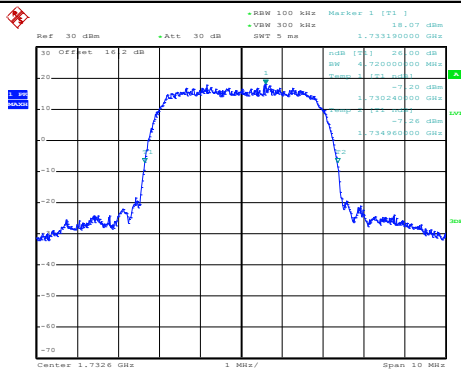

Date: 14.JAN.2018 14:00:54

Highest Channel

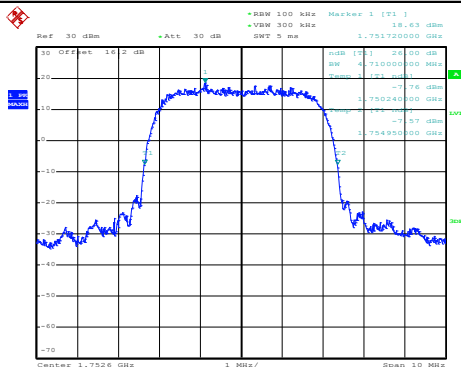

Date: 14.JAN.2018 14:02:03



### Occupied Bandwidth

Mode	WCDMA Band V	WCDMA Band II	WCDMA Band IV
Mod.	RMC 12.2Kbps	RMC 12.2Kbps	RMC 12.2Kbps
Lowest CH	4.13	4.15	4.14
Middle CH	4.14	4.15	4.14
Highest CH	4.14	4.17	4.15



WCDMA Band V (RMC 12.2Kbps)

Lowest Channel

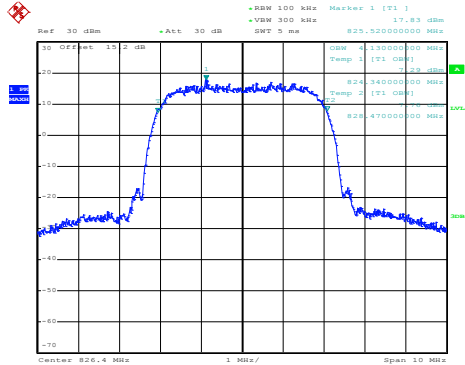

Date: 14.JAN.2018 14:18:22

WCDMA Band II (RMC 12.2Kbps)

Lowest Channel

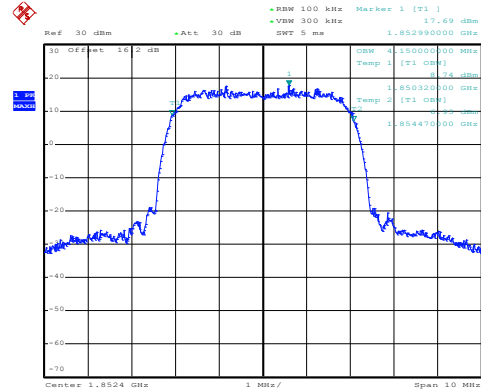

Date: 14.JAN.2018 13:46:53

Middle Channel

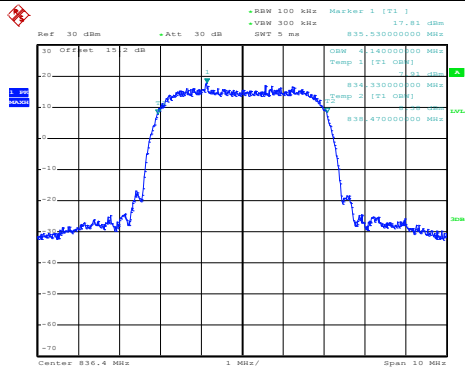

Date: 14.JAN.2018 14:18:55

Middle Channel

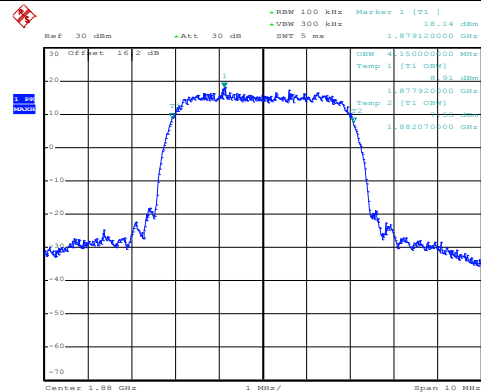

Date: 14.JAN.2018 13:47:27

Highest Channel

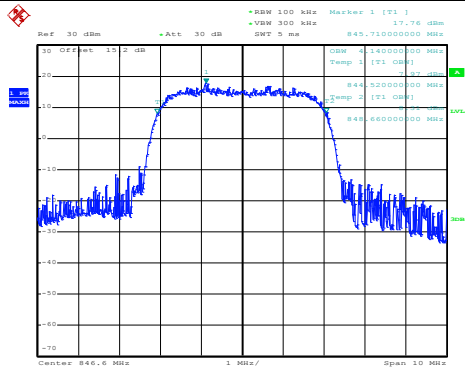

Date: 14.JAN.2018 14:19:30

Highest Channel

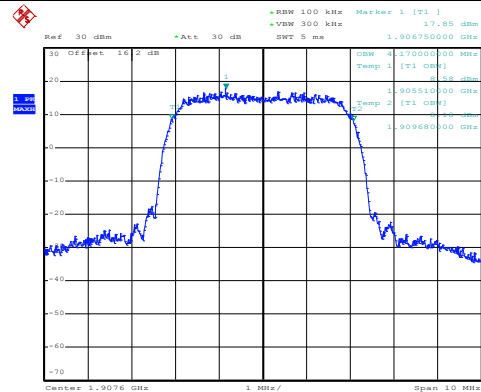

Date: 14.JAN.2018 13:48:31



WCDMA Band IV (RMC 12.2Kbps)

Lowest Channel

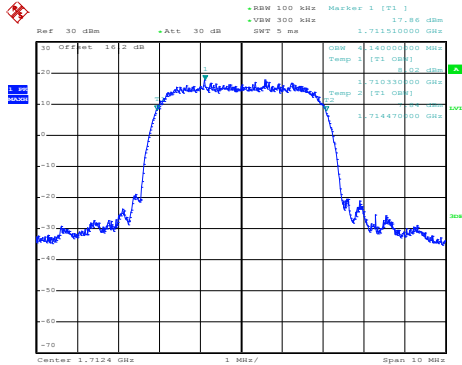

Date: 14.JAN.2018 14:02:53

Middle Channel

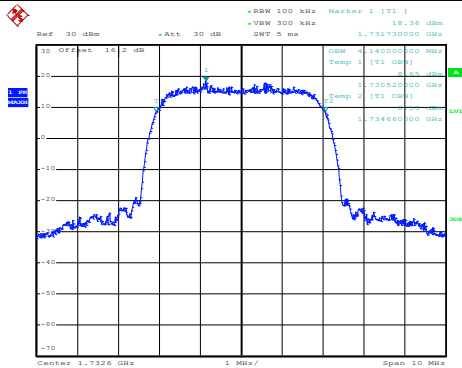

Date: 14.JAN.2018 14:03:42

Highest Channel

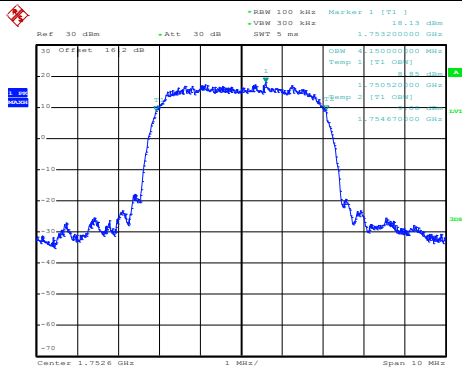

Date: 14.JAN.2018 14:04:27





## Conducted Band Edge

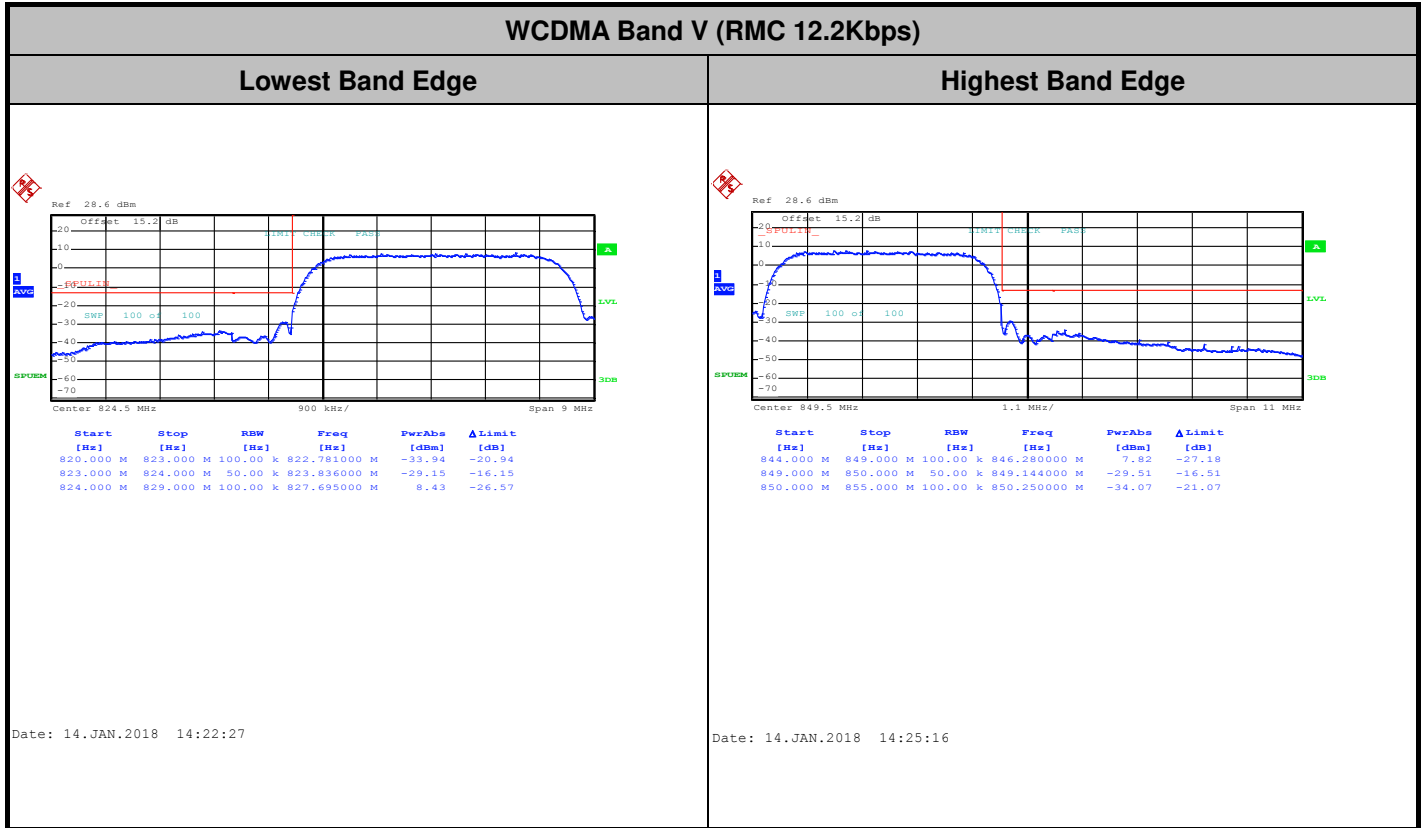



WCDMA Band II (RMC 12.2Kbps)

Lowest Band Edge

Highest Band Edge

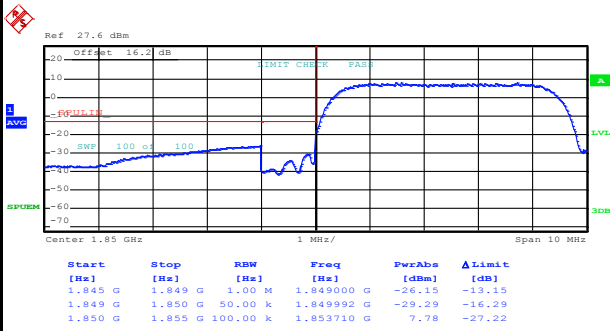

Date: 14.JAN.2018 13:51:40

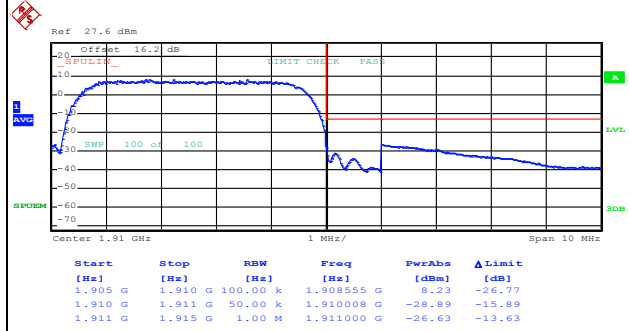

Date: 14.JAN.2018 13:54:32



WCDMA Band IV (RMC 12.2Kbps)

Lowest Band Edge

Highest Band Edge

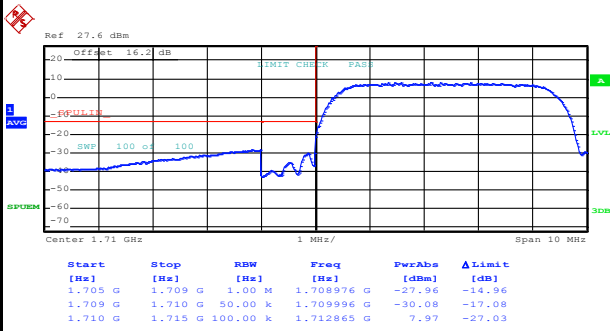

Date: 14.JAN.2018 14:07:17

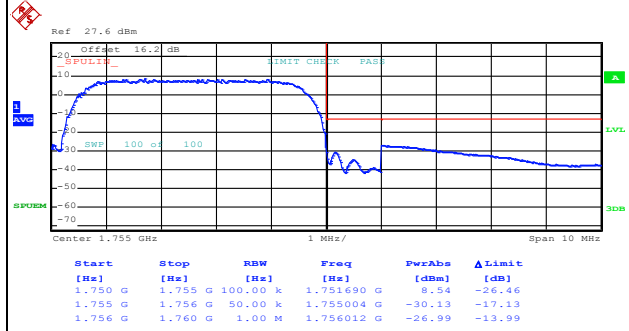

Date: 14.JAN.2018 14:10:08



# Conducted Spurious Emission

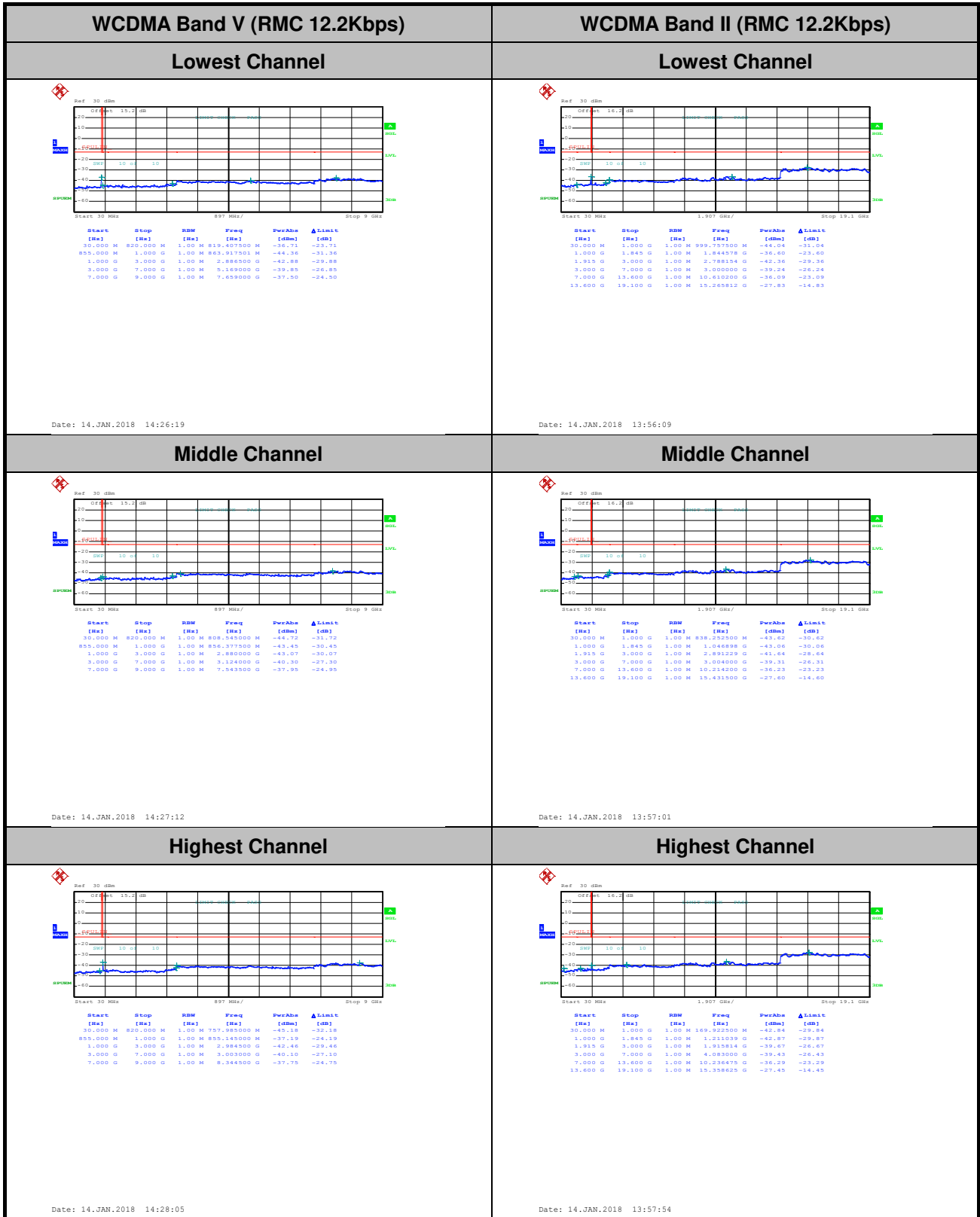



WCDMA Band IV (RMC 12.2Kbps)

Lowest Channel

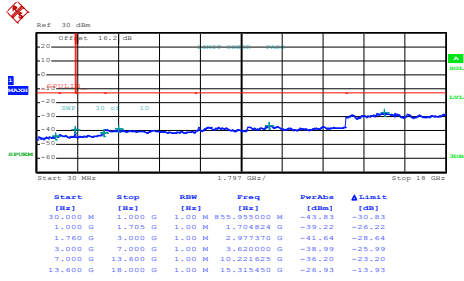

Date: 14.JAN.2018 14:11:47

Middle Channel

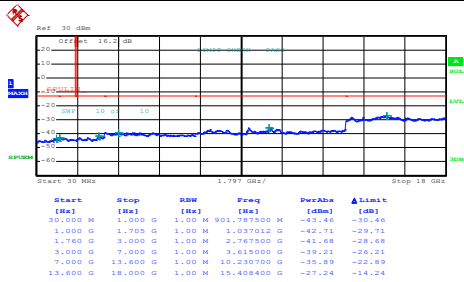

Date: 14.JAN.2018 14:12:42

Highest Channel

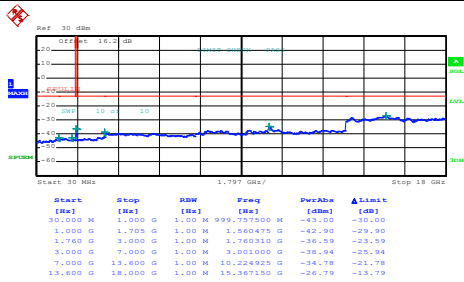

Date: 14.JAN.2018 14:13:34



**Frequency Stability**

Test Conditions	Middle Channel	WCDMA Band V (RMC 12.2Kbps)	Limit 2.5ppm
Temperature (°C)	Voltage (Volt)	Deviation (ppm)	Result
50	Normal Voltage	0.0132	PASS
40	Normal Voltage	0.0155	
30	Normal Voltage	0.0108	
20(Ref.)	Normal Voltage	0.0000	
10	Normal Voltage	0.0036	
0	Normal Voltage	0.0048	
-10	Normal Voltage	0.0024	
-20	Normal Voltage	0.0036	
-30	Normal Voltage	0.0048	
20	Maximum Voltage	0.0108	
20	Normal Voltage	0.0000	
20	Battery End Point	0.0132	

Test Conditions	Middle Channel	WCDMA Band II (RMC 12.2Kbps)	Limit Note 2.
Temperature (°C)	Voltage (Volt)	Deviation (ppm)	Result
50	Normal Voltage	0.0027	PASS
40	Normal Voltage	0.0021	
30	Normal Voltage	0.0043	
20(Ref.)	Normal Voltage	0.0000	
10	Normal Voltage	0.0074	
0	Normal Voltage	0.0064	
-10	Normal Voltage	0.0096	
-20	Normal Voltage	0.0080	
-30	Normal Voltage	0.0085	
20	Maximum Voltage	0.0005	
20	Normal Voltage	0.0000	
20	Battery End Point	0.0016	



Test Conditions	Middle Channel	WCDMA Band IV (RMC 12.2Kbps)	Limit Note 2.
Temperature (°C)	Voltage (Volt)	Deviation (ppm)	Result
50	Normal Voltage	0.0225	PASS
40	Normal Voltage	0.0237	
30	Normal Voltage	0.0214	
20(Ref.)	Normal Voltage	0.0000	
10	Normal Voltage	0.0012	
0	Normal Voltage	0.0017	
-10	Normal Voltage	0.0046	
-20	Normal Voltage	0.0058	
-30	Normal Voltage	0.0075	
20	Maximum Voltage	0.0219	
20	Normal Voltage	0.0000	
20	Battery End Point	0.0162	

**Note:**

1. Normal Voltage = 3.8V. ; Battery End Point (BEP) = 3.5 V. ; Maximum Voltage =4.4 V
2. The frequency fundamental emissions stay within the authorized frequency block.



## Appendix B. Test Results of ERP/EIRP and Radiated Test

### ERP/EIRP

Channel	Mode	Conducted		ERP	
		Power (dBm)	Power (Watts)	ERP(dBm)	ERP(W)
Lowest	GSM850	33.28	2.1281	30.42	1.1015
Middle	GPRS class 8	33.34	2.1577	30.48	1.1169
Highest	GT - LC = -0.71 dB	33.15	2.0654	30.29	1.0691
Lowest	GSM850	25.67	0.3690	22.81	0.1910
Middle	EDGE class 8	25.69	0.3707	22.83	0.1919
Highest	GT - LC = -0.71 dB	25.75	0.3758	22.89	0.1945
Lowest	WCDMA Band V	22.59	0.1816	19.73	0.0940
Middle	RMC 12.2Kbps	22.56	0.1803	19.70	0.0933
Highest	GT - LC = -0.71 dB	22.72	0.1871	19.86	0.0968
Limit	ERP < 7W	Result		PASS	

Channel	Mode	Conducted		EIRP	
		Power (dBm)	Power (Watts)	EIRP(dBm)	EIRP(W)
Lowest	GSM1900	30.54	1.1324	32.36	1.7219
Middle	GPRS class 8	30.73	1.1830	32.55	1.7989
Highest	(GT - LC = 1.82 dB)	30.62	1.1535	32.44	1.7539
Lowest	GSM1900	24.77	0.2999	26.59	0.4560
Middle	EDGE class 8	25.09	0.3228	26.91	0.4909
Highest	(GT - LC = 1.82 dB)	25.04	0.3192	26.86	0.4853
Lowest	WCDMA Band II	22.87	0.1936	24.69	0.2944
Middle	RMC 12.2Kbps	23.19	0.2084	25.01	0.3170
Highest	(GT - LC = 1.82 dB)	23.01	0.2000	24.83	0.3041
Limit	EIRP < 2W	Result		PASS	

Channel	Mode	Conducted		EIRP	
		Power (dBm)	Power (Watts)	EIRP(dBm)	EIRP(W)
Lowest	WCDMA Band IV	22.95	0.1972	24.53	0.2838
Middle	RMC 12.2Kbps	23.24	0.2109	24.82	0.3034
Highest	(GT - LC = 1.58 dB)	23.44	0.2208	25.02	0.3177
Limit	EIRP < 1W	Result		PASS	





**Radiated Spurious Emission**

**Part22H GPRS 850**

Mode 1_GPRS 850									
Channel	Frequency ( MHz )	ERP ( dBm )	Limit ( dBm )	Over Limit ( dB )	SPA Reading (dBm)	S.G. Power ( dBm )	TX Cable loss ( dB )	TX Antenna Gain (dBi)	Polarization (H/V)
Highest	1696	-38.01	-13	-25.01	-45.21	-43.56	1.24	8.94	H
	2544	-53.20	-13	-40.20	-63.15	-60.14	1.44	10.54	H
	3392	-59.58	-13	-46.58	-71.15	-67.72	1.78	12.08	H
									H
									H
									H
									H
	1696	-38.03	-13	-25.03	-44.69	-43.58	1.24	8.94	V
	2544	-54.62	-13	-41.62	-64.35	-61.56	1.44	10.54	V
	3392	-59.80	-13	-46.80	-71.21	-67.94	1.78	12.08	V
									V
									V
									V
									V

Remark: Spurious emissions within 30-1000MHz were found more than 20dB below limit line.



**Part22H WCDMA 850**

Mode 3_WCDMA 850									
Channel	Frequency ( MHz )	ERP ( dBm )	Limit ( dBm )	Over Limit ( dB )	SPA Reading (dBm)	S.G. Power ( dBm )	TX Cable loss ( dB )	TX Antenna Gain (dBi)	Polarization (H/V)
Lowest	1648	-60.52	-13	-47.52	-67.99	-65.91	1.23	8.76	H
	2480	-61.02	-13	-48.02	-71.02	-67.92	1.44	10.48	H
	3304	-59.00	-13	-46.00	-70.86	-66.95	1.71	11.81	H
									H
									H
									H
									H
	1648	-60.29	-13	-47.29	-66.78	-65.68	1.23	8.76	V
	2480	-61.09	-13	-48.09	-70.76	-67.99	1.44	10.48	V
	3304	-59.12	-13	-46.12	-70.78	-67.07	1.71	11.81	V
									V
									V
									V
									V
Middle	1672	-59.74	-13	-46.74	-67.03	-65.21	1.24	8.85	H
	2512	-61.31	-13	-48.31	-71.23	-68.23	1.44	10.51	H
	3344	-59.41	-13	-46.41	-71.16	-67.45	1.74	11.93	H
									H
									H
									H
									H
	1672	-60.23	-13	-47.23	-66.83	-65.70	1.24	8.85	V
	2512	-61.74	-13	-48.74	-71.35	-68.66	1.44	10.51	V
	3344	-59.71	-13	-46.71	-71.27	-67.75	1.74	11.93	V
									V
									V
									V
									V
								V	



Highest	1696	-60.99	-13	-47.99	-68.19	-66.54	1.24	8.94	H
	2536	-61.33	-13	-48.33	-71.27	-68.27	1.44	10.53	H
	3384	-59.73	-13	-46.73	-71.36	-67.86	1.77	12.05	H
									H
									H
									H
									H
	1696	-61.55	-13	-48.55	-68.21	-67.10	1.24	8.94	V
	2536	-61.54	-13	-48.54	-71.21	-68.48	1.44	10.53	V
	3384	-59.72	-13	-46.72	-71.18	-67.85	1.77	12.05	V
									V
									V
									V
									V

Remark: Spurious emissions within 30-1000MHz were found more than 20dB below limit line.



**Part24E GPRS 1900**

Mode 1_GPRS 1900									
Channel	Frequency ( MHz )	EIRP ( dBm )	Limit ( dBm )	Over Limit ( dB )	SPA Reading (dBm)	S.G. Power ( dBm )	TX Cable loss ( dB )	TX Antenna Gain (dBi)	Polarization (H/V)
Highest	3819	-44.16	-13	-31.16	-57.15	-54.33	2.04	12.21	H
	5729	-57.22	-13	-44.22	-72.52	-67.64	2.10	12.52	H
	7639	-53.69	-13	-40.69	-72.26	-62.08	2.11	10.50	H
									H
									H
									H
									H
	3819	-48.87	-13	-35.87	-61.35	-59.04	2.04	12.21	V
	5729	-57.40	-13	-44.40	-72.68	-67.82	2.10	12.52	V
	7639	-53.75	-13	-40.75	-72.25	-62.14	2.11	10.50	V
									V
									V
									V
									V

Remark: Spurious emissions within 30-1000MHz were found more than 20dB below limit line.



**Part24E WCDMA 1900**

Mode 3_WCDMA 1900									
Channel	Frequency ( MHz )	EIRP ( dBm )	Limit ( dBm )	Over Limit ( dB )	SPA Reading (dBm)	S.G. Power ( dBm )	TX Cable loss ( dB )	TX Antenna Gain (dBi)	Polarization (H/V)
Lowest	3704	-51.92	-13	-38.92	-64.71	-62.22	1.98	12.28	H
	5557	-57.80	-13	-44.80	-72.71	-67.94	2.14	12.28	H
	7409	-54.51	-13	-41.51	-72.55	-62.50	2.17	10.16	H
									H
									H
									H
									H
	3704	-55.91	-13	-42.91	-68.24	-66.21	1.98	12.28	V
	5557	-57.94	-13	-44.94	-72.86	-68.08	2.14	12.28	V
	7409	-54.66	-13	-41.66	-72.58	-62.65	2.17	10.16	V
									V
									V
									V
									V
Middle	3760	-57.02	-13	-44.02	-69.93	-67.26	2.01	12.24	H
	5640	-57.91	-13	-44.91	-72.85	-68.18	2.12	12.40	H
	7520	-54.48	-13	-41.48	-72.69	-62.44	2.11	10.07	H
									H
									H
									H
									H
	3760	-58.52	-13	-45.52	-70.91	-68.76	2.01	12.24	V
	5640	-58.04	-13	-45.04	-72.95	-68.31	2.12	12.40	V
	7520	-53.91	-13	-40.91	-72.3	-61.87	2.11	10.07	V
									V
									V
									V
									V



Highest	3812	-57.81	-13	-44.81	-70.76	-67.99	2.03	12.21	H
	5723	-57.41	-13	-44.41	-72.71	-67.82	2.10	12.51	H
	7627	-54.10	-13	-41.10	-72.63	-62.44	2.11	10.46	H
									H
									H
									H
									H
	3812	-59.47	-13	-46.47	-71.87	-69.65	2.03	12.21	V
	5723	-57.28	-13	-44.28	-72.56	-67.69	2.10	12.51	V
	7627	-54.26	-13	-41.26	-72.69	-62.60	2.11	10.46	V
									V
									V
									V
									V

Remark: Spurious emissions within 30-1000MHz were found more than 20dB below limit line.



**Part27L WCDMA 1700**

Mode 3 WCDMA 1900									
Channel	Frequency ( MHz )	EIRP ( dBm )	Limit ( dBm )	Over Limit ( dB )	SPA Reading (dBm)	S.G. Power ( dBm )	TX Cable loss ( dB )	TX Antenna Gain (dBi)	Polarization (H/V)
Lowest	3424	-58.69	-13	-45.69	-71.16	-69.05	1.81	12.17	H
	5137	-58.30	-13	-45.30	-72.79	-68.12	2.30	12.13	H
	6849	-55.98	-13	-42.98	-72.48	-64.66	2.37	11.05	H
									H
									H
									H
									H
	3424	-59.22	-13	-46.22	-71.47	-69.58	1.81	12.17	V
	5137	-58.16	-13	-45.16	-72.87	-67.98	2.30	12.13	V
	6849	-55.01	-13	-42.01	-72.71	-63.69	2.37	11.05	V
									V
									V
									V
									V
Middle	3465	-58.79	-13	-45.79	-71.52	-69.24	1.84	12.30	H
	5197	-58.64	-13	-45.64	-72.91	-68.50	2.28	12.14	H
	6930	-56.27	-13	-43.27	-72.87	-64.84	2.40	10.97	H
									H
									H
									H
									H
	3465	-58.99	-13	-45.99	-71.46	-69.44	1.84	12.30	V
	5197	-58.16	-13	-45.16	-72.67	-68.02	2.28	12.14	V
	6930	-54.79	-13	-41.79	-72.5	-63.36	2.40	10.97	V
									V
									V
									V
									V



Highest	3505	-58.54	-13	-45.54	-71.53	-69.06	1.87	12.40	H
	5257	-58.26	-13	-45.26	-72.67	-68.16	2.25	12.15	H
	7010	-56.22	-13	-43.22	-72.95	-64.69	2.41	10.88	H
									H
									H
									H
									H
	3505	-58.83	-13	-45.83	-71.5	-69.35	1.87	12.40	V
	5257	-58.25	-13	-45.25	-72.85	-68.15	2.25	12.15	V
	7010	-55.17	-13	-42.17	-72.89	-63.64	2.41	10.88	V
									V
									V
									V
									V

Remark: Spurious emissions within 30-1000MHz were found more than 20dB below limit line.





## **Appendix C. Original Report**

Please refer to Sporton report number FG7D2018A.