



FCC RADIO TEST REPORT

FCC ID : IHDT56XC3
Equipment : Mobile Cellular Phone
Brand Name : Motorola
Model name : XT1921-8
Applicant : Motorola Mobility LLC
222 W,Merchandise Mart Plaza, Chicago IL
60654 USA
Manufacturer : Motorola Mobility LLC
222 W,Merchandise Mart Plaza, Chicago IL
60654 USA
Standard : FCC Part 15 Subpart E §15.407

The product was received on Sep. 26, 2018 and testing was started from Nov. 13, 2018 and completed on Nov. 17, 2018. We, SPORTON INTERNATIONAL INC., would like to declare that the tested sample has been evaluated in accordance with the test procedures and has been in compliance with the applicable technical standards.

The report must not be used by the client to claim product certification, approval, or endorsement by TAF or any agency of government.

The test results in this variant report apply exclusively to the tested model / sample. Without written approval of SPORTON INTERNATIONAL INC. EMC & Wireless Communications Laboratory, the test report shall not be reproduced except in full.

Approved by: Joseph Lin

SPORTON INTERNATIONAL INC. EMC & Wireless Communications Laboratory

No. 52, Huaya 1st Rd., Guishan Dist., Taoyuan City, Taiwan (R.O.C.)



Table of Contents

History of this test report.....	3
Summary of Test Result.....	4
1 General Description	5
1.1 Product Feature of Equipment Under Test.....	5
1.2 Product Specification of Equipment Under Test.....	5
1.3 Modification of EUT	5
1.4 Testing Location	6
1.5 Applicable Standards.....	6
2 Test Configuration of Equipment Under Test	7
2.1 Carrier Frequency and Channel	7
2.2 Test Mode.....	7
2.3 Connection Diagram of Test System.....	8
2.4 Support Unit used in test configuration and system	8
2.5 EUT Operation Test Setup	8
2.6 Maximum Conducted Output Power Measurement	9
2.7 Unwanted Emissions Measurement.....	10
2.8 Automatically Discontinue Transmission	15
2.9 Antenna Requirements.....	16
3 List of Measuring Equipment.....	17
4 Uncertainty of Evaluation.....	18
Appendix A. Conducted Test Results	
Appendix B. Radiated Spurious Emission	
Appendix C. Radiated Spurious Emission Plots	
Appendix D. Duty Cycle Plots	



History of this test report

Report No.	Version	Description	Issued Date
FR892624E	01	Initial issue of report	Nov. 22, 2018



Summary of Test Result

Report Clause	Ref Std. Clause	Test Items	Result (PASS/FAIL)	Remark
-	15.403 (i)	6dB & 26dB Bandwidth	Not Required	-
-	2.1049	99% Occupied Bandwidth	Not Required	-
2.6	15.407 (a)	Maximum Conducted Output Power	Pass	-
-	15.407 (a)	Power Spectral Density	Not Required	-
2.7	15.407(b)	Unwanted Emissions	Pass	Under limit 5.40 dB at 38.370 MHz
-	15.207	AC Conducted Emission	Not Required	-
2.8	15.407 (c)	Automatically Discontinue Transmission	Pass	-
2.9	15.203 & 15.407 (a)	Antenna Requirement	Pass	-
Remark: 1. Not required means after assessing, test items are not necessary to carry out. 2. This is a variant report. All the test cases were performed on original report which can be referred to Sporton Report Number FR7D2018-03E.				

Reviewed by: **Wii Chang**

Report Producer: **Natasha Hsieh**



1 General Description

1.1 Product Feature of Equipment Under Test

Product Feature	
Equipment	Mobile Cellular Phone
Brand Name	Motorola
Model Name	XT1921-8
FCC ID	IHDT56XC3
IMEI Code	359543090013406
EUT supports Radios application	CDMA/EV-DO/GSM/EGPRS/WCDMA/HSPA/LTE/GNSS/ FM WLAN 11b/g/n HT20 WLAN 11a/n HT20/HT40 Bluetooth BR/EDR/LE
HW Version	PVT
EUT Stage	Identical Prototype

Remark: The above EUT's information was declared by manufacturer.

Accessory List	
AC Adapter 1	Brand Name : Motorola
	Model Name : SC-61
	Manufacturer : Acbel
AC Adapter 2	Brand Name : Motorola
	Model Name : SC-61
	Manufacturer : Chenyang
Battery	Brand Name : Motorola
	Model Name : GK40
	Manufacturer : Amperex
USB Cable	Brand Name : Saibao
	Model Name : SWT-A083A

1.2 Product Specification of Equipment Under Test

Standards-related Product Specification	
Tx/Rx Channel Frequency Range	5745 MHz ~ 5825 MHz
Maximum Output Power	802.11a : 15.82 dBm / 0.0382 W 802.11n HT20 : 9.98 dBm / 0.0100 W 802.11n HT40 : 9.91 dBm / 0.0098 W
Antenna Type / Gain	PIFA Antenna with gain -3.59 dBi
Type of Modulation	802.11a/n : OFDM (BPSK / QPSK / 16QAM / 64QAM)

1.3 Modification of EUT

No modifications are made to the EUT during all test items.



1.4 Testing Location

Sporton Lab is accredited to ISO 17025 by Taiwan Accreditation Foundation (TAF code : 1190) and the FCC designation No. TW1190 and TW0007 under the FCC 2.948(e) by Mutual Recognition Agreement (MRA) in FCC Test.

Test Site	SPORTON INTERNATIONAL INC.
Test Site Location	No.52, Huaya 1st Rd., Guishan Dist., Taoyuan City, Taiwan (R.O.C.) TEL: +886-3-327-3456 FAX: +886-3-328-4978
Test Site No.	Sporton Site No.
	TH05-HY

Note: The test site complies with ANSI C63.4 2014 requirement.

Test Site	SPORTON INTERNATIONAL INC.
Test Site Location	No.58, Aly. 75, Ln. 564, Wenhua 3rd, Rd., Guishan Dist., Taoyuan City, Taiwan (R.O.C.) TEL: +886-3-327-0868 FAX: +886-3-327-0855
Test Site No.	Sporton Site No.
	03CH10-HY

Note: The test site complies with ANSI C63.4 2014 requirement.

1.5 Applicable Standards

According to the specifications of the manufacturer, the EUT must comply with the requirements of the following standards:

- ♦ FCC Part 15 Subpart E
- ♦ FCC KDB 789033 D02 General UNII Test Procedures New Rules v02r01.
- ♦ FCC KDB 414788 D01 Radiated Test Site v01r01.
- ♦ ANSI C63.10-2013

Remark:

1. All test items were verified and recorded according to the standards and without any deviation during the test.
2. This EUT has also been tested and complied with the requirements of FCC Part 15, Subpart B, recorded in a separate test report.



2 Test Configuration of Equipment Under Test

- a. The EUT has been associated with peripherals and configuration operated in a manner tended to maximize its emission characteristics in a typical application. Frequency range investigated: radiation emission (9 kHz to the 10th harmonic of the highest fundamental frequency or to 40 GHz, whichever is lower). For radiated measurement, pre-scanned in three orthogonal panels, X, Y, Z. The worst cases (Y plane) were recorded in this report.

2.1 Carrier Frequency and Channel

Frequency Band	Channel	Freq. (MHz)	Channel	Freq. (MHz)
5725-5850 MHz Band 4 (U-NII-3)	149	5745	157	5785
	151*	5755	159*	5795
	153	5765	161	5805
	-	-	165	5825

Note: The above Frequency and Channel in "*" were 802.11n HT40.

2.2 Test Mode

Final test modes are considering the modulation and worse data rates as below table.

Modulation	Data Rate
802.11a	6 Mbps
802.11n HT20	MCS0
802.11n HT40	MCS0

Remark: For Radiated Test Cases, the tests were performed with Adapter 1.

Ch. #		Band IV : 5725-5850 MHz
		802.11n HT40
L	Low	-
M	Middle	-
H	High	159

2.3 Connection Diagram of Test System

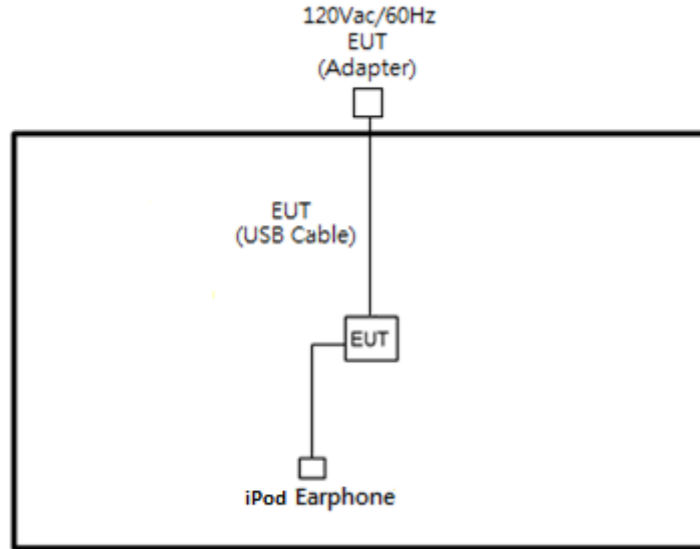

2.4 Support Unit used in test configuration and system

Item	Equipment	Trade Name	Model Name	FCC ID	Data Cable	Power Cord
1.	iPod Earphone	Apple	N/A	Verification	Unshielded, 1.0 m	N/A

2.5 EUT Operation Test Setup

The RF test items, utility “QRCT” was installed in Notebook which was programmed in order to make the EUT get into the engineering modes to provide channel selection, power level, data rate and the application type and for continuous transmitting signals.

2.6 Maximum Conducted Output Power Measurement

2.6.1 Limit of Maximum Conducted Output Power

For the band 5.725–5.85 GHz, the maximum conducted output power over the frequency band of operation shall not exceed 1 W.

If transmitting antennas of directional gain greater than 6 dBi are used, the peak output power shall be reduced by the amount in dB that the directional gain of the antenna exceeds 6 dBi.

2.6.2 Measuring Instruments

See list of measuring equipment of this test report.

2.6.3 Test Procedures

The testing follows Method PM of FCC KDB 789033 D02 General UNII Test Procedures New Rules v02r01.

Method PM (Measurement using an RF average power meter):

1. Measurement is performed using a wideband RF power meter.
2. The EUT is configured to transmit continuously with a consistent duty cycle at its maximum power control level.
3. Measure the average power of the transmitter, and the average power is corrected with duty factor, $10 \log(1/x)$, where x is the duty cycle.

2.6.4 Test Setup

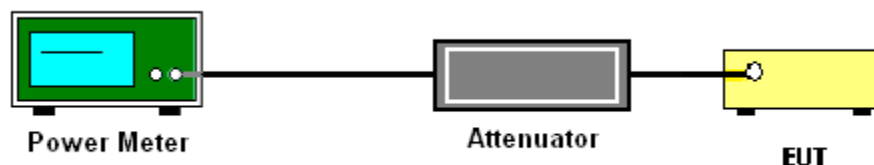

2.6.5 Test Result of Maximum Conducted Output Power

Please refer to Appendix A.



2.7 Unwanted Emissions Measurement

This section is to measure unwanted emissions through radiated measurement for band edge spurious emissions and out of band emissions measurement.

2.7.1 Limit of Unwanted Emissions

- (1) For transmitters operating in the 5.725-5.85 GHz band:
 15.407(b)(4)(i) All emissions shall be limited to a level of -27 dBm/MHz at 75 MHz or more above or below the band edge increasing linearly to 10 dBm/MHz at 25 MHz above or below the band edge, and from 25 MHz above or below the band edge increasing linearly to a level of 15.6 dBm/MHz at 5 MHz above or below the band edge, and from 5 MHz above or below the band edge increasing linearly to a level of 27 dBm/MHz at the band edge.
- (2) Unwanted spurious emissions fallen in restricted bands shall comply with the general field strength limits as below table,

Frequency (MHz)	Field Strength (microvolts/meter)	Measurement Distance (meters)
0.009 – 0.490	2400/F(kHz)	300
0.490 – 1.705	24000/F(kHz)	30
1.705 – 30.0	30	30
30 – 88	100	3
88 – 216	150	3
216 - 960	200	3
Above 960	500	3

Note: The following formula is used to convert the EIRP to field strength.

$$E = \frac{1000000\sqrt{30P}}{3} \mu\text{V/m, where P is the eirp (Watts)}$$



EIRP (dBm)	Field Strength at 3m (dBµV/m)
- 27	68.3

(3) KDB789033 D02 v02r01 G)2)c)

- (i) Section 15.407(b)(1) to (b)(3) specify the unwanted emission limits for the U-NII-1 and U-NII-2 bands. As specified, emissions above 1000 MHz that are outside of the restricted bands are subject to a peak emission limit of -27 dBm/MHz.³
- (ii) Section 15.407(b)(4) specifies the unwanted emission limit for the U-NII-3 band. A band emissions mask is specified in Section 15.407(b)(4)(i). The emission limits are in terms of a Peak detector. An alternative to the band emissions mask is specified in Section 15.407(b)(4)(ii). The alternative limits are based on the highest antenna gain specified in the filing. There are also marketing and importation restrictions for the devices using the alternative limit.⁴

Note 3: An out-of-band emission that complies with both the average and peak limits of Section 15.209 is not required to satisfy the -27 dBm/MHz peak emission limit.

Note 4: Only devices with antenna gains of 10 dBi or less may be approved using the emission limits specified in Section 15.247(d) till March 2, 2018; all other devices operating in this band must use the mask specified in Section 15.407(b)(4)(i).

2.7.2 Measuring Instruments

See list of measuring equipment of this test report.

2.7.3 Test Procedures

1. The testing follows FCC KDB 789033 D02 General UNII Test Procedures New Rules v02r01. Section G) Unwanted emissions measurement.
 - (1) Procedure for Unwanted Emissions Measurements Below 1000MHz
 - RBW = 120 kHz
 - VBW = 300 kHz
 - Detector = Peak
 - Trace mode = max hold
 - (2) Procedure for Peak Unwanted Emissions Measurements Above 1000 MHz
 - RBW = 1 MHz
 - VBW ≥ 3 MHz
 - Detector = Peak
 - Sweep time = auto
 - Trace mode = max hold



(3) Procedures for Average Unwanted Emissions Measurements Above 1000MHz

- RBW = 1 MHz
 - VBW = 10 Hz, when duty cycle is no less than 98 percent.
 - $VBW \geq 1/T$, when duty cycle is less than 98 percent where T is the minimum transmission duration over which the transmitter is on and is transmitting at its maximum power control level for the tested mode of operation.
2. The EUT was placed on a turntable with 0.8 meter for frequency below 1GHz and 1.5 meter for frequency above 1GHz respectively above ground.
 3. The EUT was set 3 meters from the interference receiving antenna which was mounted on the top of a variable height antenna tower.
 4. The antenna is a broadband antenna and its height is adjusted between one meter and four meters above ground to find the maximum value of the field strength for both horizontal polarization and vertical polarization of the antenna.
 5. For each suspected emission, the EUT was arranged to its worst case and then adjust the antenna tower (from 1 m to 4 m) and turntable (from 0 degree to 360 degrees) to find the maximum reading.
 6. For testing below 1GHz, if the emission level of the EUT in peak mode was 3 dB lower than the limit specified, then peak values of EUT will be reported, otherwise, the emissions will be repeated one by one using the CISPR quasi-peak method and reported.
 7. For testing above 1GHz, the emission level of the EUT in peak mode was 20dB lower than average limit (that means the emission level in average mode also complies with the limit in average mode), then peak values of EUT will be reported, otherwise, the emissions will be measured in average mode again and reported.

2.7.4 Test Setup

For radiated emissions below 30MHz

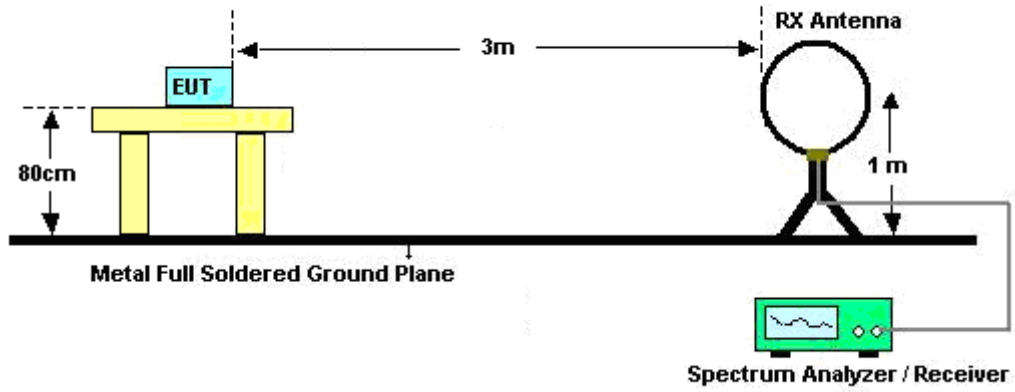

For radiated emissions from 30MHz to 1GHz

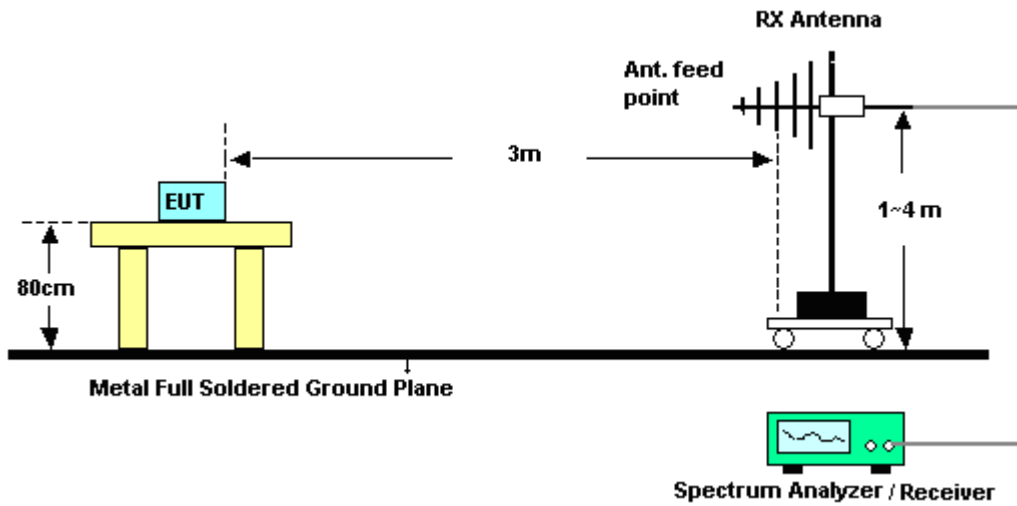

For radiated emissions above 1GHz

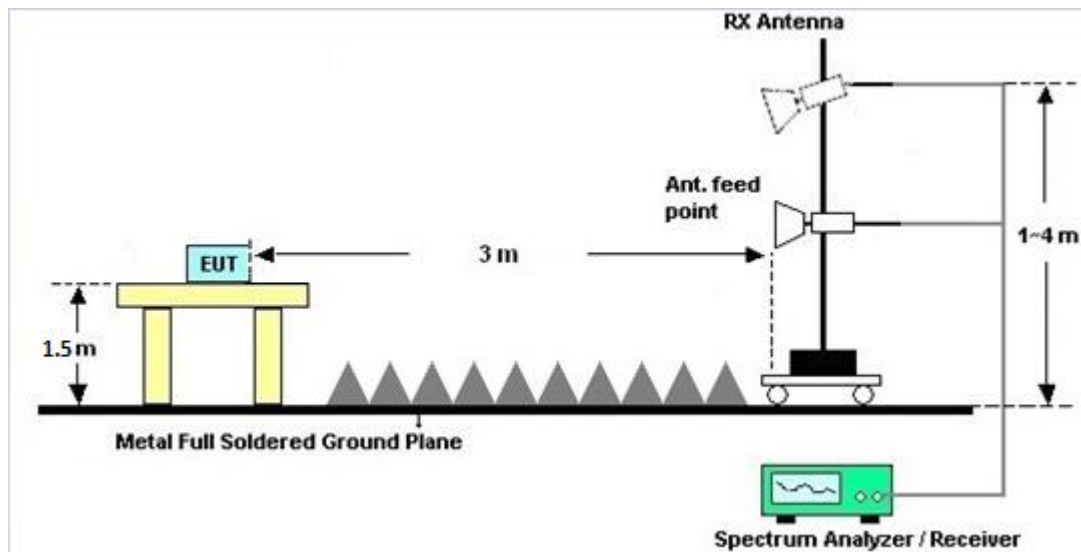

2.7.5 Test Results of Radiated Emissions (9 kHz ~ 30 MHz)

The low frequency, which started from 9 kHz to 30MHz, was pre-scanned and the result which was 20dB lower than the limit line was not reported.

There is a comparison data of both open-field test site and alternative test site - semi-Anechoic chamber according to 414788 D01 Radiated Test Site v01r01, and the result came out very similar.

2.7.6 Test Result of Radiated Band Edges

Please refer to Appendix B and C.

2.7.7 Duty Cycle

Please refer to Appendix D.

2.7.8 Test Result of Unwanted Radiated Emission (30MHz ~ 10th Harmonic)

Please refer to Appendix B and C.



2.8 Automatically Discontinue Transmission

2.8.1 Limit of Automatically Discontinue Transmission

The device shall automatically discontinue transmission in case of either absence of information to transmit or operational failure. These provisions are not intended to preclude the transmission of control or signaling information or the use of repetitive codes used by certain digital technologies to complete frame or burst intervals. Applicants shall include in their application for equipment authorization to describe how this requirement is met.

2.8.2 Measuring Instruments

See list of measuring equipment of this test report.

2.8.3 Test Result of Automatically Discontinue Transmission

While the EUT is not transmitting any information, the EUT can automatically discontinue transmission and become standby mode for power saving. The EUT can detect the controlling signal of ACK message transmitting from remote device and verify whether it shall resend or discontinue transmission.



2.9 Antenna Requirements

2.9.1 Standard Applicable

If transmitting antenna directional gain is greater than 6 dBi, both the peak transmit power and the peak power spectral density shall be reduced by the amount in dB that the directional gain of the antenna exceeds 6 dBi.

2.9.2 Antenna Anti-Replacement Construction

An embedded-in antenna design is used.

2.9.3 Antenna Gain

The antenna peak gain of EUT is less than 6 dBi. Therefore, it is not necessary to reduce maximum peak output power limit.



3 List of Measuring Equipment

Instrument	Manufacturer	Model No.	Serial No.	Characteristics	Calibration Date	Test Date	Due Date	Remark
Power Meter	Anritsu	ML2495A	1240001	N/A	Aug. 16, 2018	Nov. 13, 2018	Aug. 15, 2019	Conducted (TH05-HY)
Power Sensor	Anritsu	MA2411B	1207349	300MHz~40GHz	Aug. 16, 2018	Nov. 13, 2018	Aug. 15, 2019	Conducted (TH05-HY)
Loop Antenna	Rohde & Schwarz	HFH2-Z2	100488	9 kHz~30 MHz	Nov. 23, 2017	Nov. 15, 2018~ Nov. 17, 2018	Nov. 22, 2018	Radiation (03CH10-HY)
Bilog Antenna	TESEQ	CBL 6111D&0080 0N1D01N-06	35413&02	30MHz~1GHz	Dec. 18, 2017	Nov. 15, 2018~ Nov. 17, 2018	Dec. 17, 2018	Radiation (03CH10-HY)
Horn Antenna	SCHWARZBECK	BBHA 9120 D	9120D-1325	1GHz ~ 18GHz	Oct. 02, 2018	Nov. 15, 2018~ Nov. 17, 2018	Oct. 01, 2019	Radiation (03CH10-HY)
SHF-EHF Horn Antenna	SCHWARZBECK	BBHA 9170	BBHA91705 84	18GHz ~ 40GHz	Nov. 27, 2017	Nov. 15, 2018~ Nov. 17, 2018	Nov. 26, 2018	Radiation (03CH10-HY)
Amplifier	SONOMA	310N	187311	9kHz~1GHz	Oct. 23, 2018	Nov. 15, 2018~ Nov. 17, 2018	Oct. 22, 2019	Radiation (03CH10-HY)
Preamplifier	Keysight	83017A	MY5327007 8	1GHz~26.5GHz	Oct. 28, 2018	Nov. 15, 2018~ Nov. 17, 2018	Oct. 27, 2019	Radiation (03CH10-HY)
Preamplifier	Jet-Power	JPA0118-55- 303K	1710001800 054002	1GHz~18GHz	Apr. 17, 2018	Nov. 15, 2018~ Nov. 17, 2018	Apr. 16, 2019	Radiation (03CH10-HY)
Amplifier	MITEQ	TTA1840-35- HG	1871923	18GHz~40GHz, VSWR : 2.5:1 max	Jul. 16, 2018	Nov. 15, 2018~ Nov. 17, 2018	Jul. 15, 2019	Radiation (03CH10-HY)
Spectrum Analyzer	Keysight	N9010A	MY5420048 5	10Hz ~ 44GHz	Nov. 02, 2018	Nov. 15, 2018~ Nov. 17, 2018	Nov. 01, 2019	Radiation (03CH10-HY)
Hygrometer	TECPEL	DTM-303B	TP140320	N/A	Nov. 05, 2018	Nov. 15, 2018~ Nov. 17, 2018	Nov. 04, 2019	Radiation (03CH10-HY)
RF Cable	HUBER + SUHNER	SUCOFLEX 104 / 102	MY11692/4P E, MY11693/4P E, MY2855/2	30M~1GHz	Nov. 08, 2018	Nov. 15, 2018~ Nov. 17, 2018	Nov. 07, 2019	Radiation (03CH10-HY)
RF Cable	HUBER + SUHNER	SUCOFLEX 104 / 102	MY11692/4P E, MY11693/4P E, MY2855/2	1G~18GHz	Nov. 08, 2018	Nov. 15, 2018~ Nov. 17, 2018	Nov. 07, 2019	Radiation (03CH10-HY)
Filter	Wainwright	WLKS1200- 12SS	SN2	1.2GHz Low Pass	Mar. 21, 2018	Nov. 15, 2018~ Nov. 17, 2018	Mar. 20, 2019	Radiation (03CH10-HY)
Filter	Woken	WHKX8-527 2.5-6750-18 000-40ST	SN2	6.75G Highpass	Mar. 21, 2018	Nov. 15, 2018~ Nov. 17, 2018	Mar. 20, 2019	Radiation (03CH10-HY)
Controller	EMEC	EM 1000	N/A	Control Turn table & Ant Mast	N/A	Nov. 15, 2018~ Nov. 17, 2018	N/A	Radiation (03CH10-HY)
Antenna Mast	EMEC	AM-BS-4500 -B	N/A	1~4m	N/A	Nov. 15, 2018~ Nov. 17, 2018	N/A	Radiation (03CH10-HY)
Turn Table	EMEC	TT 2200	N/A	0~360 Degree	N/A	Nov. 15, 2018~ Nov. 17, 2018	N/A	Radiation (03CH10-HY)
Software	Audix	E3 6.2009-8-24	RK-001042	N/A	N/A	Nov. 15, 2018~ Nov. 17, 2018	N/A	Radiation (03CH10-HY)



4 Uncertainty of Evaluation

Uncertainty of Radiated Emission Measurement (30 MHz ~ 1000 MHz)

Measuring Uncertainty for a Level of Confidence of 95% ($U = 2Uc(y)$)	5.60
---	------

Uncertainty of Radiated Emission Measurement (1000 MHz ~ 18000 MHz)

Measuring Uncertainty for a Level of Confidence of 95% ($U = 2Uc(y)$)	5.90
---	------

Uncertainty of Radiated Emission Measurement (18000 MHz ~ 40000 MHz)

Measuring Uncertainty for a Level of Confidence of 95% ($U = 2Uc(y)$)	5.20
---	------

Appendix A. Test Result of Conducted Test Items

Test Engineer:	AnAn Wu	Temperature:	21~25	°C
Test Date:	2018/11/13	Relative Humidity:	51~54	%

TEST RESULTS DATA
Average Power Table

Band IV														
Mod.	Data Rate	NTX	CH.	Freq. (MHz)	Duty Factor (dB)		Average Conducted Power (dBm)			FCC Conducted Power Limit (dBm)		DG (dBi)		Pass/Fail
					Ant 1	Ant 2	Ant 1	Ant 2	SUM	Ant 1	Ant 2	Ant 1	Ant 2	
11a	6Mbps	1	149	5745	0.58	-	15.66	-		30.00	-	-3.59	-	Pass
11a	6Mbps	1	157	5785	0.58	-	15.70	-		30.00	-	-3.59	-	Pass
11a	6Mbps	1	165	5825	0.58	-	15.82	-		30.00	-	-3.59	-	Pass
HT20	MCS0	1	149	5745	0.63	-	9.85	-		30.00	-	-3.59	-	Pass
HT20	MCS0	1	157	5785	0.63	-	9.98	-		30.00	-	-3.59	-	Pass
HT20	MCS0	1	165	5825	0.63	-	9.89	-		30.00	-	-3.59	-	Pass
HT40	MCS0	1	151	5755	0.67	-	9.91	-		30.00	-	-3.59	-	Pass
HT40	MCS0	1	159	5795	0.67	-	9.75	-		30.00	-	-3.59	-	Pass



Appendix B. Radiated Spurious Emission

Test Engineer :	Peter Liao	Temperature :	22~25°C
		Relative Humidity :	52~59%

Band 4 - 5725~5850MHz

WIFI 802.11n HT40 (Band Edge @ 3m)

WIFI	Note	Frequency	Level	Over	Limit	Read	Antenna	Path	Preamp	Ant	Table	Peak	Pol.
Ant.				Limit	Line	Level	Factor	Loss	Factor	Pos	Pos	Avg.	
1		(MHz)	(dBμV/m)	(dB)	(dBμV/m)	(dBμV)	(dB/m)	(dB)	(dB)	(cm)	(deg)	(P/A)	(H/V)
802.11n HT40 CH 159 5795MHz		5631	48.06	-20.14	68.2	39.46	31.68	9.53	32.61	200	51	P	H
		5673.2	47.92	-37.49	85.41	39.29	31.74	9.52	32.63	200	51	P	H
		5714	48.23	-60.89	109.12	39.43	31.93	9.51	32.64	200	51	P	H
		5724.8	48.22	-73.52	121.74	39.41	31.95	9.51	32.65	200	51	P	H
	*	5795	98.39	-	-	89.47	32.09	9.5	32.67	200	51	P	H
	*	5795	89.04	-	-	80.12	32.09	9.5	32.67	200	51	A	H
		5850.2	48.11	-73.63	121.74	39.04	32.2	9.56	32.69	200	51	P	H
		5869.4	49.08	-57.69	106.77	39.96	32.24	9.58	32.7	200	51	P	H
		5889	48.57	-46.24	94.81	39.38	32.28	9.61	32.7	200	51	P	H
		5939	48.61	-19.59	68.2	39.13	32.53	9.67	32.72	200	51	P	H
		5630.2	47.95	-20.25	68.2	39.35	31.68	9.53	32.61	374	102	P	V
		5670.6	48.06	-35.42	83.48	39.45	31.72	9.52	32.63	374	102	P	V
		5702.6	47.97	-57.96	105.93	39.19	31.91	9.51	32.64	374	102	P	V
		5723.8	47.75	-71.71	119.46	38.94	31.95	9.51	32.65	374	102	P	V
	*	5795	96.03	-	-	87.11	32.09	9.5	32.67	374	102	P	V
	*	5795	86.59	-	-	77.67	32.09	9.5	32.67	374	102	A	V
		5851.8	48.93	-69.17	118.1	39.86	32.2	9.56	32.69	374	102	P	V
		5864	48.21	-60.07	108.28	39.09	32.23	9.58	32.69	374	102	P	V
	5878.8	48.67	-53.71	102.38	39.52	32.26	9.59	32.7	374	102	P	V	
	5928.8	48.28	-19.92	68.2	38.88	32.47	9.65	32.72	374	102	P	V	
Remark	1. No other spurious found. 2. All results are PASS against Peak and Average limit line.												



Band 4 5725~5850MHz
WIFI 802.11n HT40 (Harmonic @ 3m)

Table with 14 columns: WIFI Ant., Note, Frequency, Level, Over Limit, Limit Line, Read Level, Antenna Factor, Path Loss, Preamp Factor, Ant Pos, Table Pos, Peak Avg., Pol. Rows include test data for 802.11n HT40 CH 159 5795MHz and a Remark section.



Emission below 1GHz

5GHz WIFI 802.11n HT40 (LF @ 3m)

WIFI	Note	Frequency	Level	Over	Limit	Read	Antenna	Path	Preamp	Ant	Table	Peak	Pol.	
Ant.				Limit	Line	Level	Factor	Loss	Factor	Pos	Pos	Avg.		
1		(MHz)	(dBμV/m)	(dB)	(dBμV/m)	(dBμV)	(dB/m)	(dB)	(dB)	(cm)	(deg)	(P/A)	(H/V)	
5GHz 802.11n HT40 LF		35.94	23.48	-16.52	40	34.14	21.64	0.47	32.77	-	-	P	H	
		160.14	26.6	-16.9	43.5	41.15	16.56	1.51	32.62	-	-	P	H	
		280.02	27.65	-18.35	46	39.57	18.67	2.02	32.61	-	-	P	H	
		716.5	30	-16	46	32.35	26.97	3.22	32.54	-	-	P	H	
		848.1	32.11	-13.89	46	31.6	29.07	3.55	32.11	100	0	P	H	
		961.5	34.02	-19.98	54	30.31	31.14	3.79	31.22	-	-	P	H	
														H
														H
														H
														H
														H
														H
														H
														H
														H
														H
			38.37	34.6	-5.4	40	46.51	20.31	0.55	32.77	100	0	P	V
			165	26.79	-16.71	43.5	41.71	16.15	1.55	32.62	-	-	P	V
		275.43	26.11	-19.89	46	37.96	18.76	2	32.61	-	-	P	V	
		564.6	26.49	-19.51	46	30.24	26.11	2.83	32.69	-	-	P	V	
		930	32.62	-13.38	46	30.61	29.84	3.7	31.53	-	-	P	V	
		981.1	33.61	-20.39	54	29.99	30.81	3.84	31.03	-	-	P	V	
													V	
													V	
													V	
													V	
													V	
													V	
													V	
Remark	1. No other spurious found. 2. All results are PASS against limit line.													



Note symbol

*	Fundamental Frequency which can be ignored. However, the level of any unwanted emissions shall not exceed the level of the fundamental frequency.
!	Test result is over limit line.
P/A	Peak or Average
H/V	Horizontal or Vertical



A calculation example for radiated spurious emission is shown as below:

WIFI	Note	Frequency	Level	Over	Limit	Read	Antenna	Path	Preamp	Ant	Table	Peak	Pol.
Ant.				Limit	Line	Level	Factor	Loss	Factor	Pos	Pos	Avg.	
1		(MHz)	(dBμV/m)	(dB)	(dBμV/m)	(dBμV)	(dB/m)	(dB)	(dB)	(cm)	(deg)	(P/A)	(H/V)
802.11b		2390	55.45	-18.55	74	54.51	32.22	4.58	35.86	103	308	P	H
CH 01													
2412MHz		2390	43.54	-10.46	54	42.6	32.22	4.58	35.86	103	308	A	H

1. Path Loss(dB) = Cable loss(dB) + Filter loss(dB) + Attenuator loss(dB)
2. Level(dBμV/m) = Antenna Factor(dB/m) + Path Loss(dB) + Read Level(dBμV) - Preamp Factor(dB)
3. Over Limit(dB) = Level(dBμV/m) – Limit Line(dBμV/m)

For Peak Limit @ 2390MHz:

1. Level(dBμV/m)
= Antenna Factor(dB/m) + Path Loss(dB) + Read Level(dBμV) - Preamp Factor(dB)
= 32.22(dB/m) + 4.58(dB) + 54.51(dBμV) – 35.86 (dB)
= 55.45 (dBμV/m)
2. Over Limit(dB)
= Level(dBμV/m) – Limit Line(dBμV/m)
= 55.45(dBμV/m) – 74(dBμV/m)
= -18.55(dB)

For Average Limit @ 2390MHz:

1. Level(dBμV/m)
= Antenna Factor(dB/m) + Path Loss(dB) + Read Level(dBμV) - Preamp Factor(dB)
= 32.22(dB/m) + 4.58(dB) + 42.6(dBμV) – 35.86 (dB)
= 43.54 (dBμV/m)
2. Over Limit(dB) = Level(dBμV/m) – Limit Line(dBμV/m)
= 43.54(dBμV/m) – 54(dBμV/m)
= -10.46(dB)

Both peak and average measured complies with the limit line, so test result is “PASS”.



Appendix C. Radiated Spurious Emission Plots

Test Engineer :	Peter Liao	Temperature :	22~25°C
		Relative Humidity :	52~59%

Note symbol

-L	Low channel location
-R	High channel location



Band 4 - 5725~5850MHz
WIFI 802.11n HT40 (Band Edge @ 3m)

WIFI	Band 4 5725~5850MHz Band Edge @ 3m	
ANT	802.11n HT40 CH159 5795MHz	
1	Horizontal	Fundamental
Peak	<p>Site : 03CH10-HY Condition : PEAK_BE(B4)_16-24 3m HORN 9120D-HF HORIZONTAL Detector : Peak Project : 892624 Mode : 5 Setting : 0/-4</p>	<p>Site : 03CH10-HY Condition : PEAK(FUN1) 3m HORN 9120D-HF HORIZONTAL Detector : Peak Project : 892624 Mode : 5 Setting : 0/-4</p>
Peak	<p>Site : 03CH10-HY Condition : PEAK_BE(B4)_16-24 3m HORN 9120D-HF HORIZONTAL Detector : Peak Project : 892624 Mode : 5 Setting : 0/-4</p>	Left blank

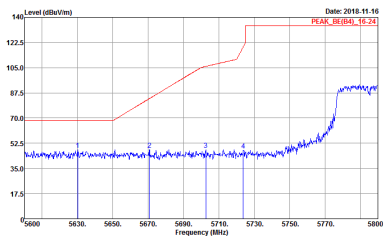
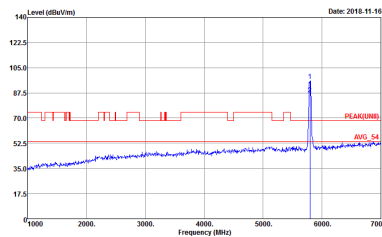
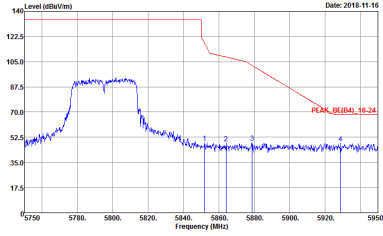

WIFI	Band 4 5725~5850MHz Band Edge @ 3m	
ANT	802.11n HT40 CH159 5795MHz	
1	Vertical	Fundamental
<p>Peak</p>	 <p>Site : 03CH10-HY Condition : PEAK_BE(B4)_16-24 3m HORN 9120D-HF VERTICAL Detector : Peak Project : 892624 Mode : 5 Setting : 0/-4</p>	 <p>Site : 03CH10-HY Condition : PEAK(LINII) 3m HORN 9120D-HF VERTICAL Detector : Peak Project : 892624 Mode : 5 Setting : 0/-4</p>
<p>Peak</p>	 <p>Site : 03CH10-HY Condition : PEAK_BE(B4)_16-24 3m HORN 9120D-HF VERTICAL Detector : Peak Project : 892624 Mode : 5 Setting : 0/-4</p>	<p>Left blank</p>



Band 4 - 5725~5850MHz
WIFI 802.11n HT40 (Harmonic @ 3m)

WIFI	Band 4 5725~5850MHz Harmonic @ 3m	
ANT	802.11n HT40 CH159 5795MHz	
1	Horizontal	Vertical
Peak Avg.	<p>Site : 05CH10-HY Condition : PEAK(UNIT) 3m HORN 91200-HF HORIZONTAL Detector : Peak Project : 892624 Mode : S Setting : Q/4</p>	<p>Site : 05CH10-HY Condition : PEAK(UNIT) 3m HORN 91200-HF VERTICAL Detector : Peak Project : 892624 Mode : S Setting : Q/4</p>



Emission below 1GHz
5GHz WIFI 802.11n HT40 (LF)

WIFI	5GHz 5725-5850MHz	
ANT	802.11n HT40 LF	
1	Horizontal	Vertical
QP / Peak	<p>Site : 03CH10-HY Condition : QP 3m BE-LOG 6111D-LF HORIZONTAL Detector : Peak Project : 892624 Mode : 6</p>	<p>Site : 03CH10-HY Condition : QP 3m BE-LOG 6111D-LF VERTICAL Detector : Peak Project : 892624 Mode : 6</p>



Appendix D. Duty Cycle Plots

Band	Duty Cycle (%)	T(us)	1/T(kHz)	VBW Setting	Duty Factor(dB)
802.11a	87.58	1375.00	0.73	1kHz	0.58
5GHz 802.11n HT20	86.53	1285.00	0.78	1kHz	0.63
5GHz 802.11n HT40	85.76	1235.00	0.80	1kHz	0.67

802.11a

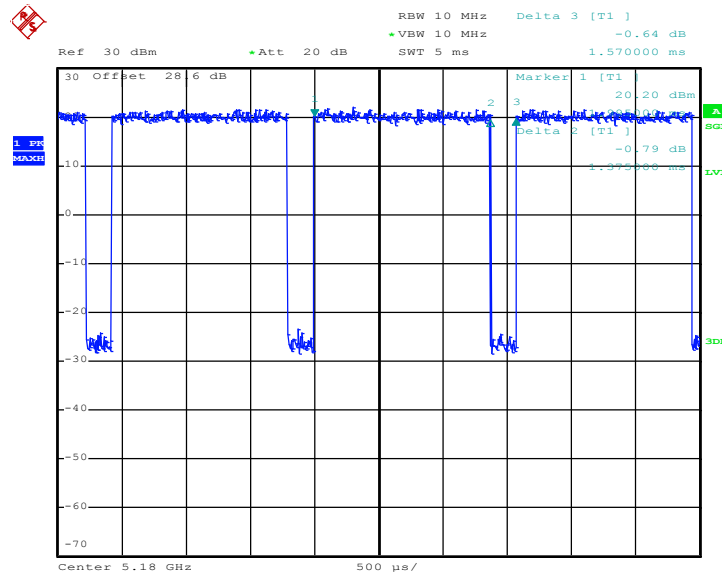

Date: 13.NOV.2018 19:53:14



802.11n HT20

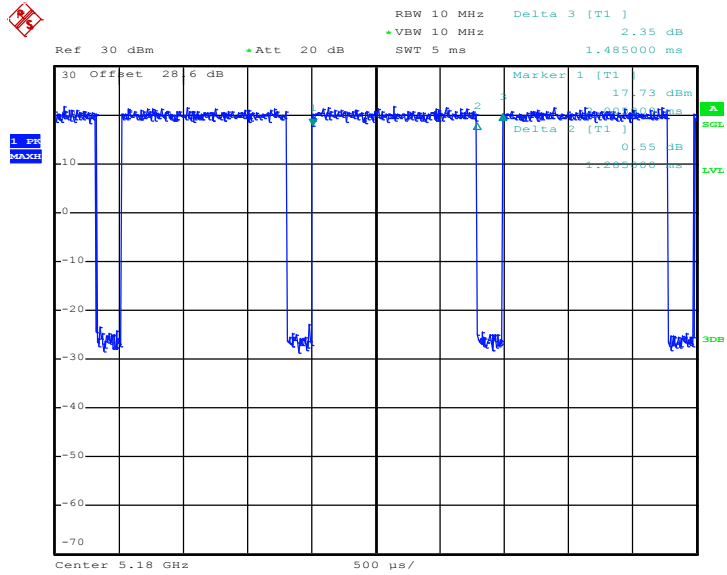

Date: 13.NOV.2018 19:54:01

802.11n HT40

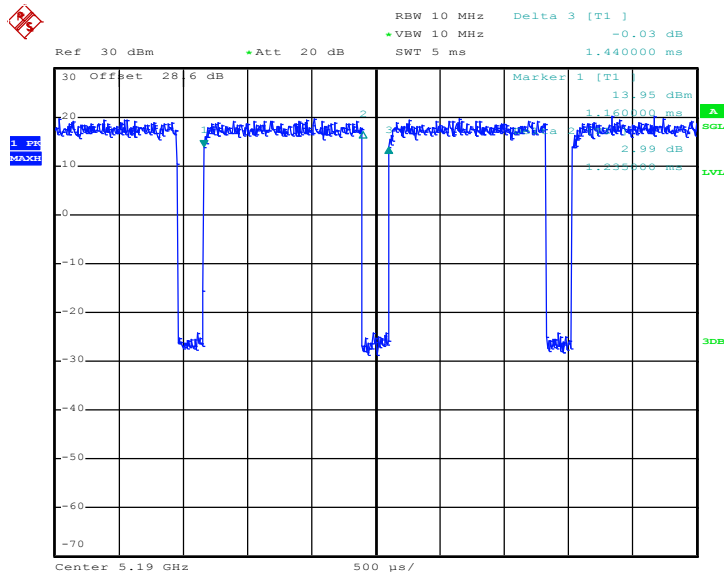

Date: 13.NOV.2018 20:02:48

—THE END—