



# FCC RF Test Report

**APPLICANT** : Motorola Mobility LLC  
**EQUIPMENT** : Mobile Cellular Phone  
**BRAND NAME** : Motorola  
**MODEL NAME** : XT1921-6, XT1921-1  
**FCC ID** : IHDT56XC1  
**STANDARD** : FCC Part 15 Subpart E §15.407  
**CLASSIFICATION** : (NII) Unlicensed National Information Infrastructure

The product was received on Dec. 20, 2017 and testing was completed on Jan. 21, 2018. We, SPORTON INTERNATIONAL INC., would like to declare that the tested sample has been evaluated in accordance with the test procedures and has been in compliance with the applicable technical standards.

The test results in this report apply exclusively to the tested model / sample. Without written approval of SPORTON INTERNATIONAL INC., the test report shall not be reproduced except in full.

Reviewed by: Joseph Lin / Supervisor

Approved by: Jones Tsai / Manager



## SPORTON INTERNATIONAL INC.

No. 52, Hwa Ya 1<sup>st</sup> Rd., Hwa Ya Technology Park, Kwei-Shan District, Tao Yuan City, Taiwan, R.O.C.

SPORTON INTERNATIONAL INC.

TEL : 886-3-327-3456

FAX : 886-3-328-4978

FCC ID: IHDT56XC1

Page Number : 1 of 28

Report Issued Date : Feb. 22, 2018

Report Version : Rev. 01

Report Template No.: BU5-FR15EWLAC MA Version 2.0



# TABLE OF CONTENTS

**REVISION HISTORY..... 3**

**SUMMARY OF TEST RESULT ..... 4**

**1 GENERAL DESCRIPTION ..... 5**

    1.1 Applicant ..... 5

    1.2 Manufacturer ..... 5

    1.3 Product Feature of Equipment Under Test ..... 5

    1.4 Product Specification of Equipment Under Test ..... 6

    1.5 Modification of EUT ..... 6

    1.6 Testing Location ..... 7

    1.7 Applicable Standards ..... 7

**2 TEST CONFIGURATION OF EQUIPMENT UNDER TEST ..... 8**

    2.1 Carrier Frequency and Channel ..... 8

    2.2 Test Mode ..... 9

    2.3 Connection Diagram of Test System ..... 10

    2.4 Support Unit used in test configuration and system ..... 11

    2.5 EUT Operation Test Setup ..... 11

    2.6 Measurement Results Explanation Example ..... 11

**3 TEST RESULT ..... 12**

    3.1 26dB & 99% Occupied Bandwidth Measurement ..... 12

    3.2 Maximum Conducted Output Power Measurement ..... 14

    3.3 Power Spectral Density Measurement ..... 16

    3.4 Unwanted Emissions Measurement ..... 18

    3.5 AC Conducted Emission Measurement ..... 23

    3.6 Automatically Discontinue Transmission ..... 25

    3.7 Antenna Requirements ..... 26

**4 LIST OF MEASURING EQUIPMENT ..... 27**

**5 UNCERTAINTY OF EVALUATION ..... 28**

**APPENDIX A. CONDUCTED TEST RESULTS**

**APPENDIX B. AC CONDUCTED EMISSION TEST RESULT**

**APPENDIX C. RADIATED SPURIOUS EMISSION**

**APPENDIX D. RADIATED SPURIOUS EMISSION PLOTS**

**APPENDIX E. DUTY CYCLE PLOTS**



### REVISION HISTORY

REPORT NO.	VERSION	DESCRIPTION	ISSUED DATE
FR7D2018-03D	Rev. 01	Initial issue of report	Feb. 22, 2018



### SUMMARY OF TEST RESULT

Report Section	FCC Rule	Description	Limit	Result	Remark
3.1	2.1049 & 15.403(i)	26dB & 99% Bandwidth	-	Pass	-
3.2	15.407(a)	Maximum Conducted Output Power	≤ 24 dBm	Pass	-
3.3	15.407(a)	Power Spectral Density	≤ 11 dBm	Pass	-
3.4	15.407(b)	Unwanted Emissions	15.407(b) & 15.209(a)	Pass	Under limit 3.81 dB at 5149.240 MHz
3.5	15.207	AC Conducted Emission	15.207(a)	Pass	Under limit 17.70 dB at 0.150 MHz
3.6	15.407(c)	Automatically Discontinue Transmission	Discontinue Transmission	Pass	-
3.7	15.203 & 15.407(a)	Antenna Requirement	N/A	Pass	-



# 1 General Description

## 1.1 Applicant

**Motorola Mobility LLC**  
222 W. Merchandise Mart Plaza, Chicago IL 60654, USA

## 1.2 Manufacturer

**Motorola Mobility LLC**  
222 W. Merchandise Mart Plaza, Chicago IL 60654, USA

## 1.3 Product Feature of Equipment Under Test

Product Feature	
<b>Equipment</b>	Mobile Cellular Phone
<b>Brand Name</b>	Motorola
<b>Model Name</b>	XT1921-6, XT1921-1
<b>FCC ID</b>	IHDT56XC1
<b>IMEI Code</b>	351838090014406 (for Radiation) 351838090015015 (for Conduction)
<b>EUT supports Radios application</b>	CDMA/EV-DO/GSM/EGPRS/WCDMA/HSPA/LTE/FM/GNSS WLAN 11b/g/n HT20 WLAN 11a/n HT20/HT40 Bluetooth BR/EDR/LE
<b>HW Version</b>	DVT1B
<b>EUT Stage</b>	Identical Prototype

**Remark:** The above EUT's information was declared by manufacturer. Please refer to the specifications or user's manual for more detailed description.

Accessory List	
<b>AC Adapter 1</b>	Brand Name : Motorola
	Model Name : C-P35
<b>AC Adapter 2</b>	Brand Name : Motorola
	Model Name : SSW-2919UMTJ C-P35 SPN5945A
<b>AC Adapter 3</b>	Brand Name : Motorola
	Model Name : C-P56
<b>AC Adapter 4</b>	Brand Name : Motorola
	Model Name : C-P56
<b>Battery</b>	Brand Name : Motorola
	Model Name : GK40
<b>USB Cable</b>	Brand Name : Saibao
	Model Name : SWT-A083A



### 1.4 Product Specification of Equipment Under Test

Standards-related Product Specification	
<b>Tx/Rx Frequency Range</b>	5180 MHz ~ 5240 MHz 5260 MHz ~ 5320 MHz 5500 MHz ~ 5700 MHz
<b>Maximum Output Power to Antenna</b>	<b>&lt;5180 MHz ~ 5240 MHz&gt;</b> 802.11a : 15.49 dBm / 0.0354 W 802.11n HT20 : 9.99 dBm / 0.0100 W 802.11n HT40 : 9.97 dBm / 0.0099 W <b>&lt;5260 MHz ~ 5320 MHz&gt;</b> 802.11a : 15.99 dBm / 0.0397 W 802.11n HT20 : 9.98 dBm / 0.0100 W 802.11n HT40 : 9.99 dBm / 0.0100 W <b>&lt;5500 MHz ~ 5700 MHz &gt;</b> 802.11a : 15.98 dBm / 0.0396 W 802.11n HT20 : 9.99 dBm / 0.0100 W 802.11n HT40 : 9.94 dBm / 0.0099 W
<b>99% Occupied Bandwidth</b>	802.11a : 20.70 MHz 802.11n HT20 : 19.15 MHz 802.11n HT40 : 36.90 MHz
<b>Antenna Type / Gain</b>	<b>&lt;5180 MHz ~ 5240 MHz&gt;</b> PIFA Antenna with gain -3.78 dBi <b>&lt;5260 MHz ~ 5320 MHz&gt;</b> PIFA Antenna with gain -3.53 dBi <b>&lt;5500 MHz ~ 5700 MHz &gt;</b> PIFA Antenna with gain -3.97 dBi
<b>Type of Modulation</b>	802.11a/n : OFDM (BPSK / QPSK / 16QAM / 64QAM)

### 1.5 Modification of EUT

No modifications are made to the EUT during all test items.



### 1.6 Testing Location

Sporton Lab is accredited to ISO 17025 by Taiwan Accreditation Foundation (TAF code : 1190) and the FCC designation No. TW1190 and TW0007 under the FCC 2.948(e) by Mutual Recognition Agreement (MRA) in FCC Test.

<b>Test Site</b>	SPORTON INTERNATIONAL INC.	
<b>Test Site Location</b>	No. 52, Hwa Ya 1 <sup>st</sup> Rd., Hwa Ya Technology Park, Kwei-Shan District, Tao Yuan City, Taiwan, R.O.C. TEL: +886-3-327-3456 FAX: +886-3-328-4978	
<b>Test Site No.</b>	<b>Sporton Site No.</b>	
	TH05-HY	CO05-HY

**Note:** The test site complies with ANSI C63.4 2014 requirement.

<b>Test Site</b>	SPORTON INTERNATIONAL INC.	
<b>Test Site Location</b>	No.58, Aly. 75, Ln. 564, Wenhua 3rd Rd. Guishan Dist, Taoyuan City, Taiwan (R.O.C.) TEL: +886-3-327-0868 FAX: +886-3-327-0855	
<b>Test Site No.</b>	<b>Sporton Site No.</b>	
	03CH10-HY	

**Note:** The test site complies with ANSI C63.4 2014 requirement.

### 1.7 Applicable Standards

According to the specifications of the manufacturer, the EUT must comply with the requirements of the following standards:

- ♦ FCC Part 15 Subpart E
- ♦ FCC KDB 789033 D02 General UNII Test Procedures New Rules v02r01.
- ♦ ANSI C63.10-2013

**Remark:**

1. All test items were verified and recorded according to the standards and without any deviation during the test.
2. This EUT has also been tested and complied with the requirements of FCC Part 15, Subpart B, recorded in a separate test report.



## 2 Test Configuration of Equipment Under Test

- a. The EUT has been associated with peripherals and configuration operated in a manner tended to maximize its emission characteristics in a typical application. Frequency range investigated: conduction emission (150 kHz to 30 MHz), radiation emission (9 kHz to the 10th harmonic of the highest fundamental frequency or to 40 GHz, whichever is lower). For radiated measurement, pre-scanned in three orthogonal panels, X, Y, Z. The worst cases (X plane) were recorded in this report.
- b. AC power line Conducted Emission was tested under maximum output power.

### 2.1 Carrier Frequency and Channel

Frequency Band	Channel	Freq. (MHz)	Channel	Freq. (MHz)
5150-5250 MHz Band 1 (U-NII-1)	36	5180	44	5220
	38*	5190	46*	5230
	40	5200	48	5240
	-	-		

Frequency Band	Channel	Freq. (MHz)	Channel	Freq. (MHz)
5250-5350 MHz Band 2 (U-NII-2A)	52	5260	60	5300
	54*	5270	62*	5310
	56	5280	64	5320
	-	-		

Frequency Band	Channel	Freq. (MHz)	Channel	Freq. (MHz)
5470-5725 MHz Band 3 (U-NII-2C)	100	5500	112	5560
	102*	5510	116	5580
	104	5520	132	5660
	-	-	134*	5670
	108	5540	136	5680
	110*	5550	140	5700

Frequency Band	Channel	Freq. (MHz)	Channel	Freq. (MHz)
TDWR Channel	118*	5590	124	5620
	120	5600	126*	5630
	-	-	128	5640

Note: The above Frequency and Channel in "\*" were 802.11n HT40





## 2.2 Test Mode

Final test modes are considering the modulation and worse data rates as below table.

Modulation	Data Rate
802.11a	6 Mbps
802.11n HT20	MCS0
802.11n HT40	MCS0

Test Cases	
<b>AC Conducted Emission</b>	Mode 1 : GSM 1900 Idle + Bluetooth Link + WLAN (5GHz) Link + SD Card + MP3 + Earphone + USB Cable (Charging from Adapter 1)
<b>Remark:</b> For Radiated Test Cases, The tests were performance with Adapter 1	

Ch. #		Band I : 5150-5250 MHz	Band II : 5250-5350 MHz	Band III : 5470-5725MHz
		802.11a	802.11a	802.11a
L	Low	36	52	100
M	Middle	44	60	116
H	High	48	64	140

Ch. #		Band I : 5150-5250 MHz	Band II : 5250-5350 MHz	Band III : 5470-5725MHz
		802.11n HT20	802.11n HT20	802.11n HT20
L	Low	36	52	100
M	Middle	44	60	116
H	High	48	64	140

Ch. #		Band I : 5150-5250 MHz	Band II : 5250-5350 MHz	Band III : 5470-5725MHz
		802.11n HT40	802.11n HT40	802.11n HT40
L	Low	38	54	102
M	Middle	-	-	110
H	High	46	62	134

## 2.3 Connection Diagram of Test System

<WLAN Tx Mode>

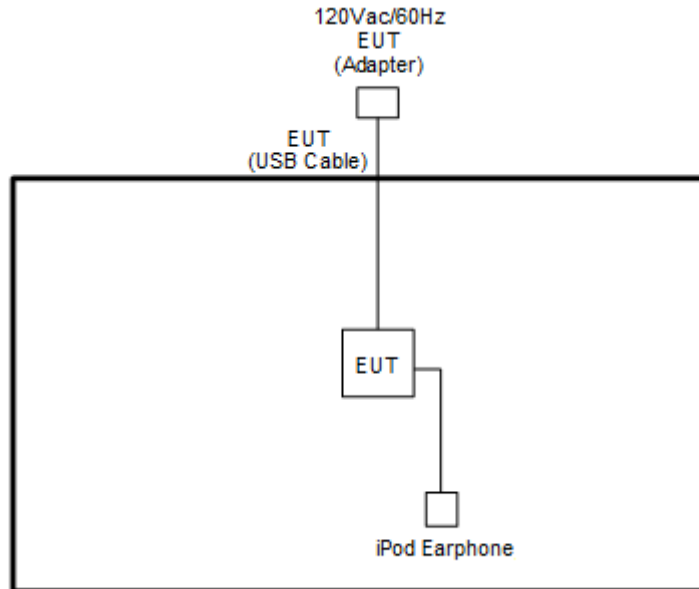

<AC Conducted Emission Mode>

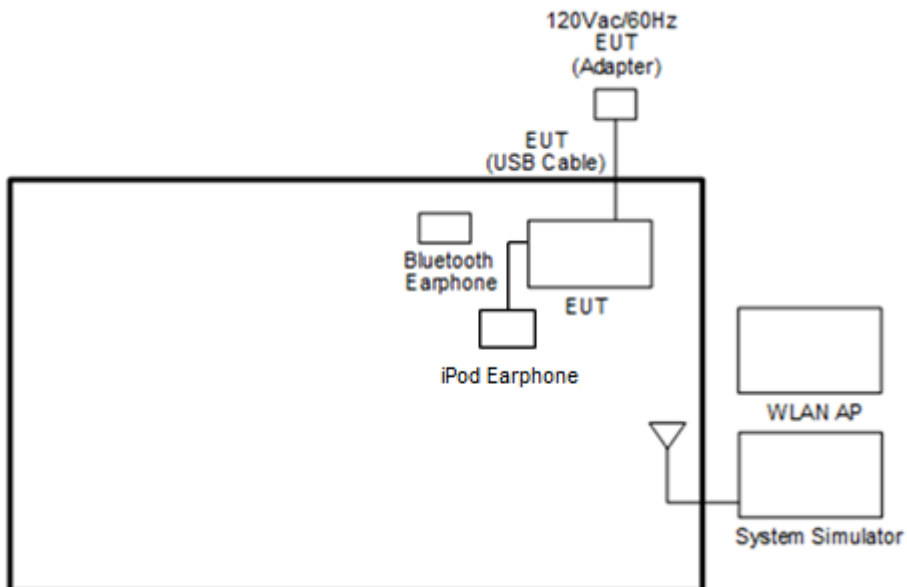



## 2.4 Support Unit used in test configuration and system

Item	Equipment	Trade Name	Model Name	FCC ID	Data Cable	Power Cord
1.	System Simulator	Anritsu	MT8820C	N/A	N/A	Unshielded, 1.8 m
2.	WLAN AP	ASUS	RT-AC66U	MSQ-RTAC66U	N/A	Unshielded, 1.8m
3.	iPod Earphone	Apple	N/A	Verification	Unshielded, 1.0 m	N/A
4.	Bluetooth Earphone	Lenovo	LBH 301	FCC DoC	N/A	N/A
5.	SD Card	SanDisk	MicroSD HC	FCC DoC	N/A	N/A

## 2.5 EUT Operation Test Setup

The RF test items, utility “QRCT” was installed in Notebook which was programmed in order to make the EUT get into the engineering modes to provide channel selection, power level, data rate and the application type and for continuous transmitting signals.

## 2.6 Measurement Results Explanation Example

**For all conducted test items:**

The offset level is set in the spectrum analyzer to compensate the RF cable loss and attenuator factor between EUT conducted output port and spectrum analyzer. With the offset compensation, the spectrum analyzer reading level is exactly the EUT RF output level.

Example :

The spectrum analyzer offset is derived from RF cable loss and attenuator factor.

*Offset = RF cable loss + attenuator factor.*

Following shows an offset computation example with cable loss 4.2 dB and 10dB attenuator.

$$\begin{aligned}
 \text{Offset(dB)} &= \text{RF cable loss(dB)} + \text{attenuator factor(dB)}. \\
 &= 4.2 + 10 = 14.2 \text{ (dB)}
 \end{aligned}$$

### 3 Test Result

#### 3.1 26dB & 99% Occupied Bandwidth Measurement

##### 3.1.1 Description of 26dB & 99% Occupied Bandwidth

This section is for reporting purpose only.

There is no restriction limits for bandwidth.

##### 3.1.2 Measuring Instruments

The measuring equipment is listed in the section 4 of this test report.

##### 3.1.3 Test Procedures

1. The testing follows FCC KDB 789033 D02 General UNII Test Procedures New Rules v02r01. Section C) Emission bandwidth
2. Set RBW = approximately 1% of the emission bandwidth.
3. Set the VBW > RBW.
4. Detector = Peak.
5. Trace mode = max hold
6. Measure the maximum width of the emission that is 26 dB down from the peak of the emission. Compare this with the RBW setting of the analyzer. Readjust RBW and repeat measurement as needed until the RBW/EBW ratio is approximately 1%.
7. For 99% Bandwidth Measurement, the spectrum analyzer's resolution bandwidth (RBW) is set 1MHz and set the Video bandwidth (VBW)  $\geq 3 * RBW$ .
8. Measure and record the results in the test report.

##### 3.1.4 Test Setup

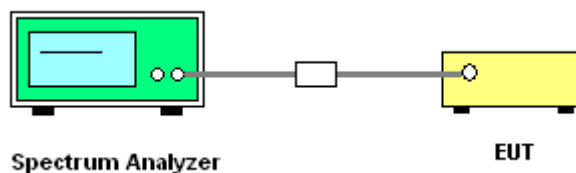

##### 3.1.5 Test Result of 26dB & 99% Occupied Bandwidth

Please refer to Appendix A.

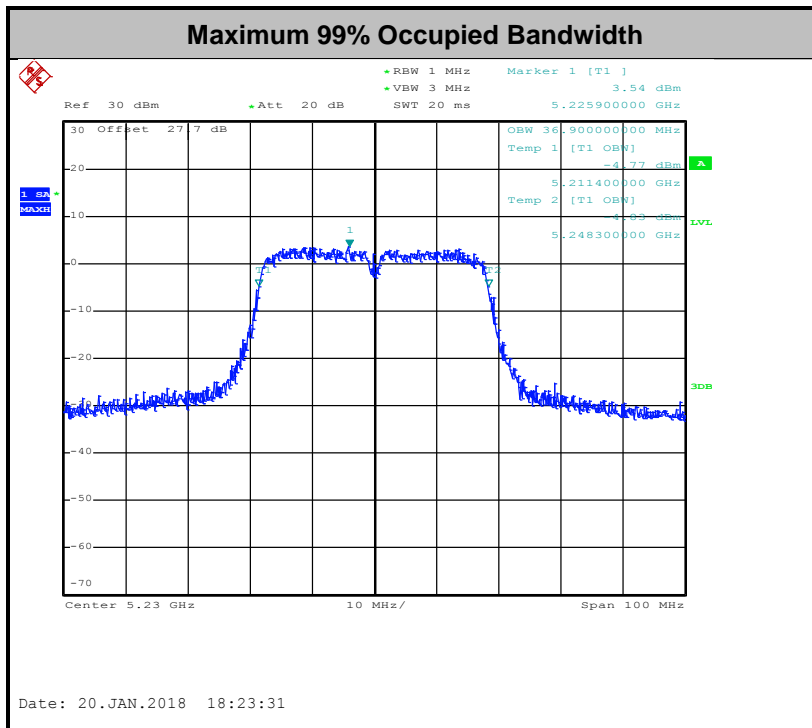
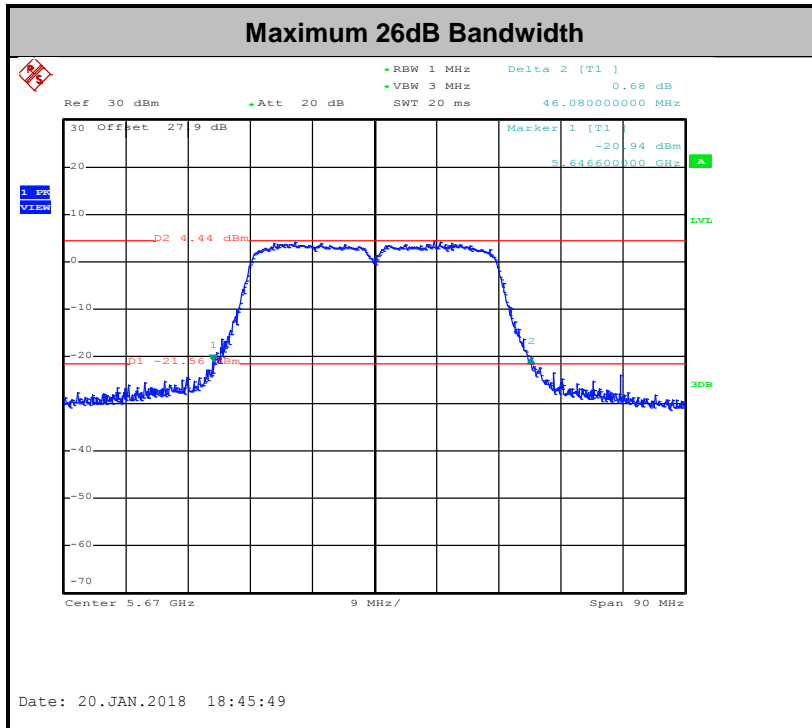

**Note:** The occupied channel bandwidth is maintained within the band of operation for all of the modulations.



## 3.2 Maximum Conducted Output Power Measurement

### 3.2.1 Limit of Maximum Conducted Output Power

<FCC 14-30 CFR 15.407>

For mobile and portable client devices in the 5.15–5.25 GHz band, the maximum conducted output power over the frequency band of operation shall not exceed 250 mW.

For the 5.25–5.725 GHz bands, the maximum conducted output power over the frequency bands of operation shall not exceed the lesser of 250 mW or  $11 \text{ dBm} + 10 \log B$ , where B is the 26 dB emission bandwidth in megahertz.

If transmitting antennas of directional gain greater than 6 dBi are used, the peak output power shall be reduced by the amount in dB that the directional gain of the antenna exceeds 6 dBi.

Note that U-NII-2 band, devices with a maximum e.i.r.p. greater than 500 mW shall implement TPC in order to have the capability to operate at least 6 dB below the maximum permitted e.i.r.p. of 1 W.

### 3.2.2 Measuring Instruments

The measuring equipment is listed in the section 4 of this test report.

### 3.2.3 Test Procedures

The testing follows Method PM of FCC KDB 789033 D02 General UNII Test Procedures New Rules v02r01.

Method PM (Measurement using an RF average power meter):

1. Measurement is performed using a wideband RF power meter.
2. The EUT is configured to transmit continuously with a consistent duty cycle at its maximum power control level.
3. Measure the average power of the transmitter, and the average power is corrected with duty factor,  $10 \log(1/x)$ , where x is the duty cycle.

### 3.2.4 Test Setup

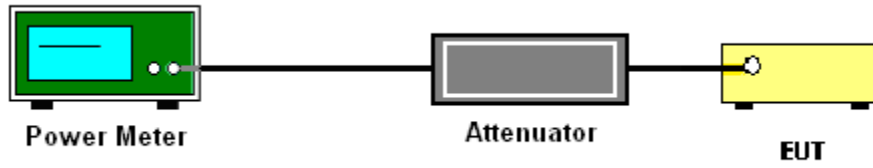

### 3.2.5 Test Result of Maximum Conducted Output Power

Please refer to Appendix A.



### 3.3 Power Spectral Density Measurement

#### 3.3.1 Limit of Power Spectral Density

<FCC 14-30 CFR 15.407>

For an indoor access point operating in the band 5.15-5.25 GHz, the maximum power spectral density shall not exceed 17 dBm in any 1 megahertz band.

For the 5.25–5.725 GHz bands, the maximum power spectral density shall not exceed 11 dBm in any 1 megahertz band.

If transmitting antennas of directional gain greater than 6 dBi are used, the peak output power shall be reduced by the amount in dB that the directional gain of the antenna exceeds 6 dBi.

#### 3.3.2 Measuring Instruments

The measuring equipment is listed in the section 4 of this test report.

#### 3.3.3 Test Procedures

The testing follows FCC KDB 789033 D02 General UNII Test Procedures New Rules v02r01. Section F) Maximum power spectral density.

**# Method SA-2 #**

(trace averaging across on and off times of the EUT transmissions, followed by duty cycle correction).

- Measure the duty cycle.
  - Set span to encompass the entire emission bandwidth (EBW) of the signal.
  - Set RBW = 1 MHz.
  - Set VBW  $\geq$  3 MHz.
  - Number of points in sweep  $\geq$  2 Span / RBW.
  - Sweep time = auto.
  - Detector = RMS
  - Trace average at least 100 traces in power averaging mode.
  - Add  $10 \log(1/x)$ , where x is the duty cycle, to the measured power in order to compute the average power during the actual transmission times. For example, add  $10 \log(1/0.25) = 6$  dB if the duty cycle is 25 percent.
1. The RF output of EUT was connected to the spectrum analyzer by a low loss cable.
  2. Each plot has already offset with cable loss, and attenuator loss. Measure the PPSD and record it.



### 3.3.4 Test Setup

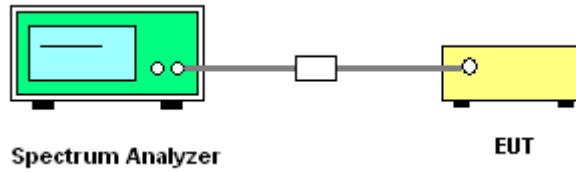

### 3.3.5 Test Result of Power Spectral Density

Please refer to Appendix A.

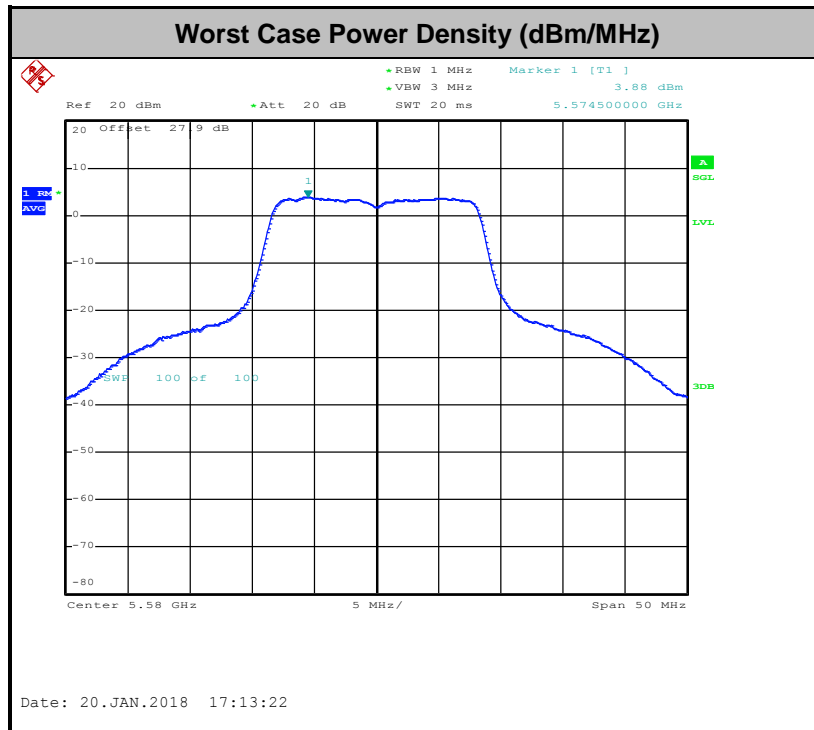

**Note:** Average Power Density (dB) = Measured value+ Duty Factor



### 3.4 Unwanted Emissions Measurement

This section is to measure unwanted emissions through radiated measurement for band edge spurious emissions and out of band emissions measurement.

#### 3.4.1 Limit of Unwanted Emissions

- (1) For transmitters operating in the 5150-5250 MHz band: all emissions outside of the 5150-5350 MHz band shall not exceed an EIRP of -27dBm/MHz.

For transmitters operating in the 5250-5350 MHz band: all emissions outside of the 5150-5350 MHz band shall not exceed an EIRP of -27 dBm/MHz. Devices operating in the 5250-5350 MHz band that generate emissions in the 5150-5250 MHz band must meet all applicable technical requirements for operation in the 5150-5250 MHz band (including indoor use) or alternatively meet an out-of-band emission EIRP limit of -27 dBm/MHz in the 5150-5250 MHz band.

For transmitters operating in the 5470-5600 MHz and 5650-5725MHz band: all emissions outside of the 5470-5600 MHz and 5650-5725MHz band shall not exceed an EIRP of -27 dBm/MHz.

- (2) Unwanted spurious emissions fallen in restricted bands shall comply with the general field strength limits as below table,

Frequency (MHz)	Field Strength (microvolts/meter)	Measurement Distance (meters)
0.009 – 0.490	2400/F(kHz)	300
0.490 – 1.705	24000/F(kHz)	30
1.705 – 30.0	30	30
30 – 88	100	3
88 – 216	150	3
216 - 960	200	3
Above 960	500	3

**Note:** The following formula is used to convert the EIRP to field strength.

$$E = \frac{1000000\sqrt{30P}}{3} \mu\text{V/m, where P is the eirp (Watts)}$$



EIRP (dBm)	Field Strength at 3m (dBµV/m)
-17	78.3
- 27	68.3

(3) KDB789033 D02 v02r01 G)2)c)

- (i) Section 15.407(b)(1) to (b)(3) specify the unwanted emission limits for the U-NII-1 and U-NII-2 bands. As specified, emissions above 1000 MHz that are outside of the restricted bands are subject to a peak emission limit of -27 dBm/MHz.<sup>3</sup>
- (ii) Section 15.407(b)(4) specifies the unwanted emission limit for the U-NII-3 band. A band emissions mask is specified in Section 15.407(b)(4)(i). The emission limits are in terms of a Peak detector. An alternative to the band emissions mask is specified in Section 15.407(b)(4)(ii). The alternative limits are based on the highest antenna gain specified in the filing. There are also marketing and importation restrictions for the devices using the alternative limit.<sup>4</sup>

**Note 3:** An out-of-band emission that complies with both the average and peak limits of Section 15.209 is not required to satisfy the -27 dBm/MHz peak emission limit.

**Note 4:** Only devices with antenna gains of 10 dBi or less may be approved using the emission limits specified in Section 15.247(d) till March 2, 2018; all other devices operating in this band must use the mask specified in Section 15.407(b)(4)(i).

### 3.4.2 Measuring Instruments

The measuring equipment is listed in the section 4 of this test report.



### 3.4.3 Test Procedures

1. The testing follows FCC KDB 789033 D02 General UNII Test Procedures New Rules v02r01. Section G) Unwanted emissions measurement.
  - (1) Procedure for Unwanted Emissions Measurements Below 1000MHz
    - RBW = 120 kHz
    - VBW = 300 kHz
    - Detector = Peak
    - Trace mode = max hold
  - (2) Procedure for Peak Unwanted Emissions Measurements Above 1000 MHz
    - RBW = 1 MHz
    - VBW  $\geq$  3 MHz
    - Detector = Peak
    - Sweep time = auto
    - Trace mode = max hold
  - (3) Procedures for Average Unwanted Emissions Measurements Above 1000MHz
    - RBW = 1 MHz
    - VBW = 10 Hz, when duty cycle is no less than 98 percent.
    - VBW  $\geq$  1/T, when duty cycle is less than 98 percent where T is the minimum transmission duration over which the transmitter is on and is transmitting at its maximum power control level for the tested mode of operation.
2. The EUT was placed on a turntable with 0.8 meter for frequency below 1GHz and 1.5 meter for frequency above 1GHz respectively above ground.
3. The EUT was set 3 meters from the interference receiving antenna which was mounted on the top of a variable height antenna tower.
4. The antenna is a broadband antenna and its height is adjusted between one meter and four meters above ground to find the maximum value of the field strength for both horizontal polarization and vertical polarization of the antenna.
5. For each suspected emission, the EUT was arranged to its worst case and then adjust the antenna tower (from 1 m to 4 m) and turntable (from 0 degree to 360 degrees) to find the maximum reading.
6. For testing below 1GHz, if the emission level of the EUT in peak mode was 3 dB lower than the limit specified, then peak values of EUT will be reported, otherwise, the emissions will be repeated one by one using the CISPR quasi-peak method and reported.

- 7. For testing above 1GHz, the emission level of the EUT in peak mode was 20dB lower than average limit (that means the emission level in average mode also complies with the limit in average mode), then peak values of EUT will be reported, otherwise, the emissions will be measured in average mode again and reported.

### 3.4.4 Test Setup

For radiated emissions below 30MHz

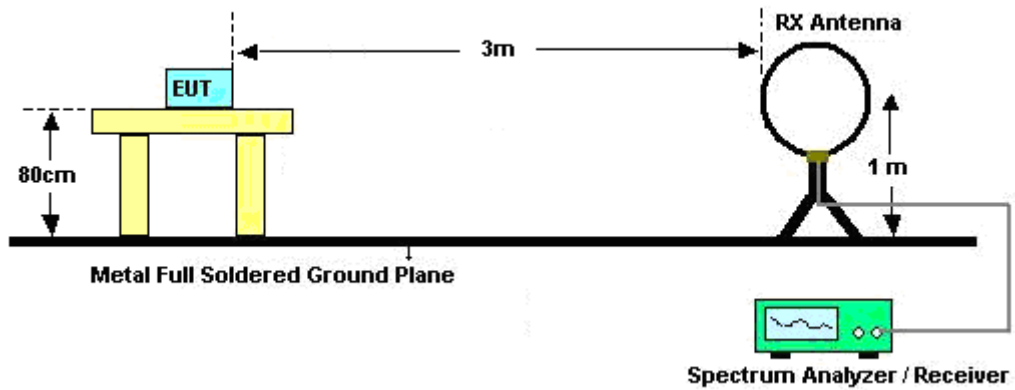

For radiated emissions from 30MHz to 1GHz

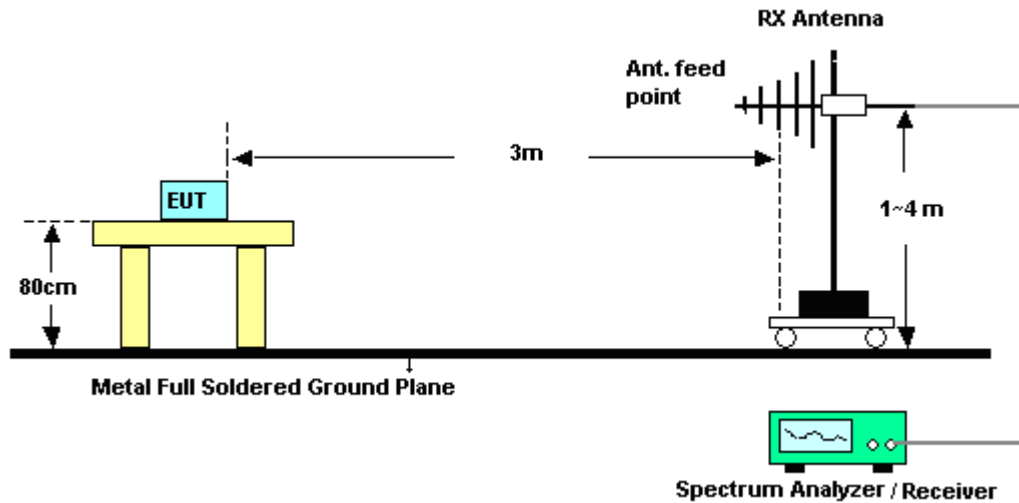

For radiated emissions above 1GHz

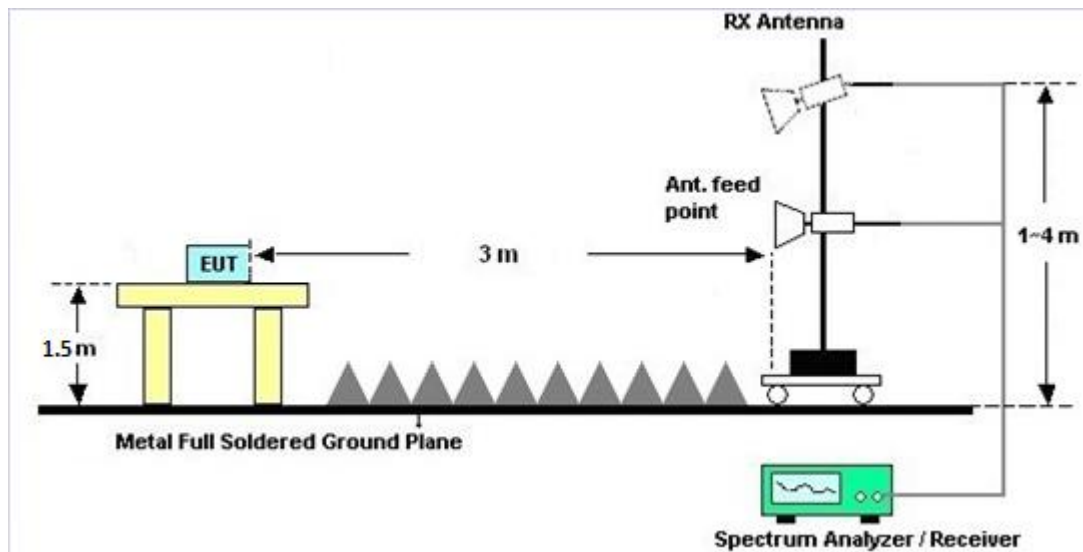

### 3.4.5 Test Results of Radiated Spurious Emissions (9 kHz ~ 30 MHz)

The low frequency, which started from 9 kHz to 30MHz, was pre-scanned and the result which was 20dB lower than the limit line was not reported.

There is a comparison data of both open-field test site and semi-Anechoic chamber, and the result came out very similar.

### 3.4.6 Test Result of Radiated Spurious at Band Edges

Please refer to Appendix C and D.

### 3.4.7 Duty Cycle

Please refer to Appendix E.

### 3.4.8 Test Result of Radiated Spurious Emissions (30MHz ~ 10th Harmonic)

Please refer to Appendix C and D.



### 3.5 AC Conducted Emission Measurement

#### 3.5.1 Limit of AC Conducted Emission

For equipment that is designed to be connected to the public utility (AC) power line, the radio frequency voltage that is conducted back onto the AC power line on any frequency or frequencies within the band 150 kHz to 30 MHz shall not exceed the limits in the following table.

Frequency of emission (MHz)	Conducted limit (dBµV)	
	Quasi-peak	Average
0.15-0.5	66 to 56*	56 to 46*
0.5-5	56	46
5-30	60	50

\*Decreases with the logarithm of the frequency.

#### 3.5.2 Measuring Instruments

The measuring equipment is listed in the section 4 of this test report.

#### 3.5.3 Test Procedures

1. The EUT was placed 0.4 meter from the conducting wall of the shielding room was kept at least 80 centimeters from any other grounded conducting surface.
2. Connect EUT to the power mains through a line impedance stabilization network (LISN).
3. All the support units are connecting to the other LISN.
4. The LISN provides 50 ohm coupling impedance for the measuring instrument.
5. The FCC states that a 50 ohm, 50 microhenry LISN should be used.
6. Both sides of AC line were checked for maximum conducted interference.
7. The frequency range from 150 kHz to 30 MHz was searched.
8. Set the test-receiver system to Peak Detect Function and specified bandwidth with Maximum Hold Mode.

### 3.5.4 Test Setup

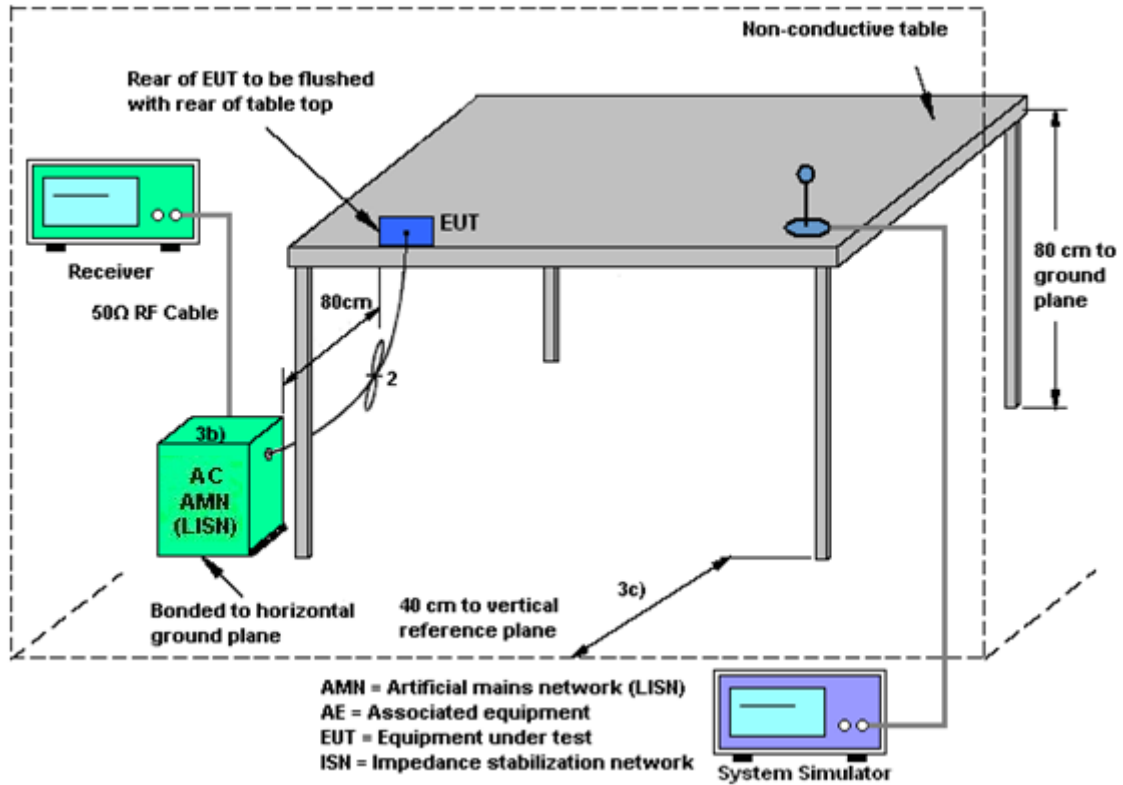

### 3.5.5 Test Result of AC Conducted Emission

Please refer to Appendix B.





## **3.6 Automatically Discontinue Transmission**

### **3.6.1 Limit of Automatically Discontinue Transmission**

The device shall automatically discontinue transmission in case of either absence of information to transmit or operational failure. These provisions are not intended to preclude the transmission of control or signaling information or the use of repetitive codes used by certain digital technologies to complete frame or burst intervals. Applicants shall include in their application for equipment authorization to describe how this requirement is met.

### **3.6.2 Measuring Instruments**

The measuring equipment is listed in the section 4 of this test report.

### **3.6.3 Test Result of Automatically Discontinue Transmission**

While the EUT is not transmitting any information, the EUT can automatically discontinue transmission and become standby mode for power saving. The EUT can detect the controlling signal of ACK message transmitting from remote device and verify whether it shall resend or discontinue transmission.



## **3.7 Antenna Requirements**

### **3.7.1 Standard Applicable**

If transmitting antenna directional gain is greater than 6 dBi, both the peak transmit power and the peak power spectral density shall be reduced by the amount in dB that the directional gain of the antenna exceeds 6 dBi.

### **3.7.2 Antenna Anti-Replacement Construction**

An embedded-in antenna design is used.

### **3.7.3 Antenna Gain**

The antenna peak gain of EUT is less than 6 dBi. Therefore, it is not necessary to reduce maximum peak output power limit.



## 4 List of Measuring Equipment

Instrument	Manufacturer	Model No.	Serial No.	Characteristics	Calibration Date	Test Date	Due Date	Remark
Power Meter	Anritsu	ML2495A	1240001	N/A	Sep. 07, 2017	Jan. 04, 2018~ Jan. 20, 2018	Sep. 06, 2018	Conducted (TH05-HY)
Power Sensor	Anritsu	MA2411B	1207349	300MHz~40GHz	Sep. 07, 2017	Jan. 04, 2018~ Jan. 20, 2018	Sep. 06, 2018	Conducted (TH05-HY)
Spectrum Analyzer	Rohde & Schwarz	FSP40	100055	9kHz~40GHz	Jun. 20, 2017	Jan. 04, 2018~ Jan. 20, 2018	Jun. 19, 2018	Conducted (TH02-HY)
AC Power Source	ChainTek	APC-1000W	N/A	N/A	N/A	Jan. 09, 2018	N/A	Conduction (CO05-HY)
EMI Test Receiver	Rohde & Schwarz	ESCI 7	100724	9kHz~7GHz	Sep. 20, 2017	Jan. 09, 2018	Sep. 19, 2018	Conduction (CO05-HY)
LISN	Rohde & Schwarz	ENV216	100080	9kHz~30MHz	Nov. 30, 2017	Jan. 09, 2018	Nov. 29, 2018	Conduction (CO05-HY)
Loop Antenna	Rohde & Schwarz	HFH2-Z2	100315	9 kHz~30 MHz	May 15, 2017	Jan. 04, 2018~ Jan. 21, 2018	May 14, 2019	Radiation (03CH10-HY)
Amplifier	SONOMA	310N	187311	9kHz~1GHz	Oct. 19, 2017	Jan. 04, 2018~ Jan. 21, 2018	Oct. 18, 2018	Radiation (03CH10-HY)
Amplifier	MITEQ	TTA1840-35-HG	1871923	18GHz~40GHz, VSWR : 2.5:1 max	Jul. 18, 2017	Jan. 04, 2018~ Jan. 21, 2018	Jul. 17, 2018	Radiation (03CH10-HY)
Bilog Antenna	TESEQ	CBL 6111D&N-6-0 6	35414&AT- N0602	30MHz~1GHz	Oct. 14, 2017	Jan. 04, 2018~ Jan. 21, 2018	Oct. 13, 2018	Radiation (03CH10-HY)
Horn Antenna	SCHWARZBE CK	BBHA 9120 D	9120D-132 5	1GHz ~ 18GHz	Sep. 27, 2017	Jan. 04, 2018~ Jan. 21, 2018	Sep. 26, 2018	Radiation (03CH10-HY)
Preamplifier	Keysight	83017A	MY532700 78	1GHz~26.5GHz	Oct. 25, 2017	Jan. 04, 2018~ Jan. 21, 2018	Oct. 24, 2018	Radiation (03CH10-HY)
Spectrum Analyzer	Keysight	N9010A	MY542004 85	10Hz ~ 44GHz	Oct. 31, 2017	Jan. 04, 2018~ Jan. 21, 2018	Oct. 30, 2018	Radiation (03CH10-HY)
Preamplifier	MITEQ	AMF-7D-0010 1800	2025787	1GHZ~18GHZ	Feb.13, 2017	Jan. 04, 2018~ Jan. 21, 2018	Feb. 12, 2018	Radiation (03CH10-HY)
Antenna Mast	EMEC	AM-BS-4500- B	N/A	1~4m	N/A	Jan. 04, 2018~ Jan. 21, 2018	N/A	Radiation (03CH10-HY)
Turn Table	EMEC	TT 2200	N/A	0~360 Degree	N/A	Jan. 04, 2018~ Jan. 21, 2018	N/A	Radiation (03CH10-HY)
EMI Test Receiver	Agilent	N9038A (MXE)	MY54201 70	20Hz to 26.5GHz	Mar. 03, 2017	Jan. 04, 2018~ Jan. 21, 2018	Mar. 02, 2018	Radiation (03CH10-HY)
SHF-EHF Horn Antenna	SCHWARZBE CK	BBHA 9170	BBHA9170 584	18GHz- 40GHz	Nov. 27, 2017	Jan. 04, 2018~ Jan. 21, 2018	Nov. 26, 2018	Radiation (03CH10-HY)



## 5 Uncertainty of Evaluation

### Uncertainty of Conducted Emission Measurement (150kHz ~ 30MHz)

Measuring Uncertainty for a Level of Confidence of 95% ( $U = 2Uc(y)$ )	2.70
---	------

### Uncertainty of Radiated Emission Measurement (30 MHz ~ 1000 MHz)

Measuring Uncertainty for a Level of Confidence of 95% ( $U = 2Uc(y)$ )	5.60
---	------

### Uncertainty of Radiated Emission Measurement (1000 MHz ~ 18000 MHz)

Measuring Uncertainty for a Level of Confidence of 95% ( $U = 2Uc(y)$ )	5.90
---	------

### Uncertainty of Radiated Emission Measurement (18000 MHz ~ 40000 MHz)

Measuring Uncertainty for a Level of Confidence of 95% ( $U = 2Uc(y)$ )	5.20
---	------

**Appendix A. Test Result of Conducted Test Items**

Test Engineer:	Reece Lin / Kai Liao	Temperature:	21~25	°C
Test Date:	2018/1/4 ~ 2018/01/20	Relative Humidity:	51~54	%

**TEST RESULTS DATA**  
**26dB and 99% OBW**

Band I										
Mod.	Data Rate	NTX	CH.	Freq. (MHz)	99% Bandwidth (MHz)	26 dB Bandwidth (MHz)	IC 99% Bandwidth Power Limit (dBm)	IC 99% Bandwidth EIRP Limit (dBm)		
11a	6Mbps	1	36	5180	19.20	41.36	-	22.83		
11a	6Mbps	1	44	5220	19.00	41.90	-	22.79		
11a	6Mbps	1	48	5240	19.15	40.10	-	22.82		
HT20	MCS0	1	36	5180	19.15	26.90	-	22.82		
HT20	MCS0	1	44	5220	19.15	25.30	-	22.82		
HT20	MCS0	1	48	5240	18.60	23.80	-	22.70		
HT40	MCS0	1	38	5190	36.70	45.18	-	23.01		
HT40	MCS0	1	46	5230	36.90	45.36	-	23.01		

**TEST RESULTS DATA**  
**Average Power Table**

FCC Band I										
Mod.	Data Rate	NTX	CH.	Freq. (MHz)	Duty Factor (dB)	Average Conducted Power (dBm)	FCC Conducted Power Limit (dBm)	DG (dBi)		Pass/Fail
11a	6Mbps	1	36	5180	0.59	15.49	24.00	-3.78		Pass
11a	6Mbps	1	44	5220	0.59	15.41	24.00	-3.78		Pass
11a	6Mbps	1	48	5240	0.59	15.44	24.00	-3.78		Pass
HT20	MCS0	1	36	5180	0.63	9.94	24.00	-3.78		Pass
HT20	MCS0	1	44	5220	0.63	9.87	24.00	-3.78		Pass
HT20	MCS0	1	48	5240	0.63	9.99	24.00	-3.78		Pass
HT40	MCS0	1	38	5190	0.47	9.95	24.00	-3.78		Pass
HT40	MCS0	1	46	5230	0.47	9.97	24.00	-3.78		Pass

**TEST RESULTS DATA**  
**Power Spectral Density**

FCC Band I										
Mod.	Data Rate	NTX	CH.	Freq. (MHz)	Duty Factor (dB)	Average Power Density (dBm/MHz)	Average PSD Limit (dBm/MHz)	DG (dBi)	-	Pass/Fail
11a	6Mbps	1	36	5180	0.59	4.17	11.00	-3.78		Pass
11a	6Mbps	1	44	5220	0.59	3.47	11.00	-3.78		Pass
11a	6Mbps	1	48	5240	0.59	3.35	11.00	-3.78		Pass
HT20	MCS0	1	36	5180	0.63	-1.76	11.00	-3.78		Pass
HT20	MCS0	1	44	5220	0.63	-2.27	11.00	-3.78		Pass
HT20	MCS0	1	48	5240	0.63	-2.15	11.00	-3.78		Pass
HT40	MCS0	1	38	5190	0.47	-4.74	11.00	-3.78		Pass
HT40	MCS0	1	46	5230	0.47	-5.32	11.00	-3.78		Pass



**TEST RESULTS DATA**  
**26dB and 99% OBW**

Band II										
Mod.	Data Rate	NTX	CH.	Freq. (MHz)	99% Bandwidth (MHz)	26 dB Bandwidth (MHz)	IC 99% Bandwidth Power Limit (dBm)	IC 99% Bandwidth EIRP Limit (dBm)	FCC 26dB Bandwidth Power Limit (dBm)	Note
11a	6M bps	1	52	5260	19.25	43.16	23.84	29.84	23.98	
11a	6M bps	1	60	5300	19.30	41.64	23.86	29.86	23.98	
11a	6M bps	1	64	5320	19.00	41.35	23.79	29.79	23.98	
HT20	MCS 0	1	52	5260	19.00	25.05	23.79	29.79	23.98	
HT20	MCS 0	1	60	5300	19.05	27.40	23.80	29.80	23.98	
HT20	MCS 0	1	64	5320	19.05	24.25	23.80	29.80	23.98	
HT40	MCS 0	1	54	5270	36.70	45.54	23.98	30.00	23.98	
HT40	MCS 0	1	62	5310	36.70	45.36	23.98	30.00	23.98	

**TEST RESULTS DATA**  
**Average Power Table**

FCC Band II										
Mod.	Data Rate	NTX	CH.	Freq. (MHz)	Duty Factor (dB)	Average Conducted Power (dBm)	FCC Conducted Power Limit (dBm)	DG (dBi)	EIRP Power Limit (dBm)	Pass/Fail
11a	6M bps	1	52	5260	0.59	15.95	23.98	-3.53	26.99	Pass
11a	6M bps	1	60	5300	0.59	15.89	23.98	-3.53	26.99	Pass
11a	6M bps	1	64	5320	0.59	15.99	23.98	-3.53	26.99	Pass
HT20	MCS 0	1	52	5260	0.63	9.94	23.98	-3.53	26.99	Pass
HT20	MCS 0	1	60	5300	0.63	9.98	23.98	-3.53	26.99	Pass
HT20	MCS 0	1	64	5320	0.63	9.85	23.98	-3.53	26.99	Pass
HT40	MCS 0	1	54	5270	0.47	9.89	23.98	-3.53	26.99	Pass
HT40	MCS 0	1	62	5310	0.47	9.99	23.98	-3.53	26.99	Pass

**TEST RESULTS DATA**  
**Power Spectral Density**

Band II										
Mod.	Data Rate	NTX	CH.	Freq. (MHz)	Duty Factor (dB)	Average Power Density (dBm/MHz)	Average PSD Limit (dBm/MHz)	DG (dBi)		Pass/Fail
11a	6M bps	1	52	5260	0.59	3.67	11.00	-3.53		Pass
11a	6M bps	1	60	5300	0.59	3.78	11.00	-3.53		Pass
11a	6M bps	1	64	5320	0.59	3.83	11.00	-3.53		Pass
HT20	MCS 0	1	52	5260	0.63	-2.78	11.00	-3.53		Pass
HT20	MCS 0	1	60	5300	0.63	-2.43	11.00	-3.53		Pass
HT20	MCS 0	1	64	5320	0.63	-2.65	11.00	-3.53		Pass
HT40	MCS 0	1	54	5270	0.47	-5.45	11.00	-3.53		Pass
HT40	MCS 0	1	62	5310	0.47	-5.61	11.00	-3.53		Pass

**TEST RESULTS DATA**  
**26dB and 99% OBW**

Band III										
Mod.	Data Rate	NTX	CH.	Freq. (MHz)	99% Bandwidth In UNII-2C (MHz)	26 dB Bandwidth In UNII-2C (MHz)	IC 99% Bandwidth Power Limit (dBm)	IC 99% Bandwidth EIRP Limit (dBm)	FCC 26dB Bandwidth Power Limit (dBm)	6dB Bandwidth for Straddle Channel (MHz)
11a	6M bps	1	100	5500	18.90	41.10	23.76	29.76	23.98	----
11a	6M bps	1	116	5580	19.20	42.24	23.83	29.83	23.98	----
11a	6M bps	1	140	5700	20.70	43.30	23.98	30.00	23.98	----
HT20	MCS 0	1	100	5500	19.00	24.60	23.79	29.79	23.98	----
HT20	MCS 0	1	116	5580	19.10	24.00	23.81	29.81	23.98	----
HT20	MCS 0	1	140	5700	19.05	24.60	23.80	29.80	23.98	----
HT40	MCS 0	1	102	5510	36.50	45.90	23.98	30.00	23.98	----
HT40	MCS 0	1	110	5550	36.70	46.08	23.98	30.00	23.98	----
HT40	MCS 0	1	134	5670	36.80	46.08	23.98	30.00	23.98	----

**TEST RESULTS DATA**  
**Average Power Table**

FCC Band III										
Mod.	Data Rate	NTX	CH.	Freq. (MHz)	Duty Factor (dB)	Average Conducted Power (dBm)	FCC Conducted Power Limit (dBm)	DG (dBi)	EIRP Power Limit (dBm)	Pass/Fail
11a	6M bps	1	100	5500	0.59	15.94	23.98	-3.97	26.99	Pass
11a	6M bps	1	116	5580	0.59	15.97	23.98	-3.97	26.99	Pass
11a	6M bps	1	140	5700	0.59	15.98	23.98	-3.97	26.99	Pass
HT20	MCS 0	1	100	5500	0.63	9.99	23.98	-3.97	26.99	Pass
HT20	MCS 0	1	116	5580	0.63	9.98	23.98	-3.97	26.99	Pass
HT20	MCS 0	1	140	5700	0.63	9.93	23.98	-3.97	26.99	Pass
HT40	MCS 0	1	102	5510	0.47	9.94	23.98	-3.97	26.99	Pass
HT40	MCS 0	1	110	5550	0.47	9.87	23.98	-3.97	26.99	Pass
HT40	MCS 0	1	134	5670	0.47	9.82	23.98	-3.97	26.99	Pass

**TEST RESULTS DATA**  
**Power Spectral Density**

Band III										
Mod.	Data Rate	NTX	CH.	Freq. (MHz)	Duty Factor (dB)	Average Power Density (dBm/MHz)	Average PSD Limit (dBm/MHz)	DG (dBi)		Pass/Fail
11a	6M bps	1	100	5500	0.59	4.37	11.00	-3.97		Pass
11a	6M bps	1	116	5580	0.59	4.47	11.00	-3.97		Pass
11a	6M bps	1	140	5700	0.59	3.43	11.00	-3.97		Pass
HT20	MCS 0	1	100	5500	0.63	-2.00	11.00	-3.97		Pass
HT20	MCS 0	1	116	5580	0.63	-1.77	11.00	-3.97		Pass
HT20	MCS 0	1	140	5700	0.63	-2.34	11.00	-3.97		Pass
HT40	MCS 0	1	102	5510	0.47	-5.07	11.00	-3.97		Pass
HT40	MCS 0	1	110	5550	0.47	-4.52	11.00	-3.97		Pass
HT40	MCS 0	1	134	5670	0.47	-5.34	11.00	-3.97		Pass



## Appendix B. AC Conducted Emission Test Results

Test Engineer :	Blue Lan	Temperature :	24~25°C
		Relative Humidity :	46~48%

# EUT Information

Report NO : 7D2018-03  
 Test Mode : Mode 1  
 Test Voltage : 120Vac/60Hz  
 Phase : Line

ENV216 Auto Test FCC Power Bar - L

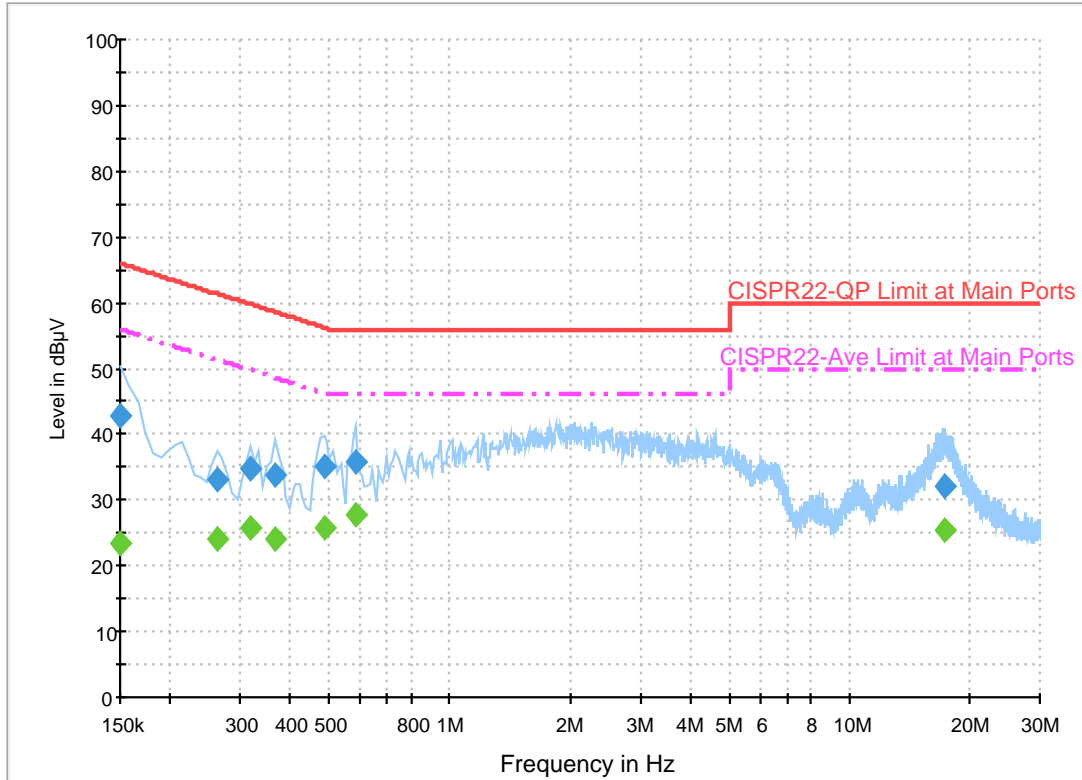

## Final Result 1

Frequency (MHz)	QuasiPeak (dBµV)	Filter	Line	Corr. (dB)	Margin (dB)	Limit (dBµV)
0.150000	43.0	Off	L1	19.5	23.0	66.0
0.262000	33.1	Off	L1	19.5	28.3	61.4
0.318000	34.7	Off	L1	19.5	25.1	59.8
0.366000	33.8	Off	L1	19.5	24.8	58.6
0.486000	35.2	Off	L1	19.5	21.0	56.2
0.582000	35.9	Off	L1	19.5	20.1	56.0
17.294000	32.0	Off	L1	19.8	28.0	60.0

## Final Result 2

Frequency (MHz)	Average (dBµV)	Filter	Line	Corr. (dB)	Margin (dB)	Limit (dBµV)
0.150000	23.5	Off	L1	19.5	32.5	56.0
0.262000	24.2	Off	L1	19.5	27.2	51.4
0.318000	25.7	Off	L1	19.5	24.1	49.8
0.366000	24.0	Off	L1	19.5	24.6	48.6
0.486000	25.7	Off	L1	19.5	20.5	46.2
0.582000	27.8	Off	L1	19.5	18.2	46.0
17.294000	25.5	Off	L1	19.8	24.5	50.0



# EUT Information

Report NO : 7D2018-03  
 Test Mode : Mode 1  
 Test Voltage : 120Vac/60Hz  
 Phase : Neutral

ENV216 Auto Test FCC Power Bar - N

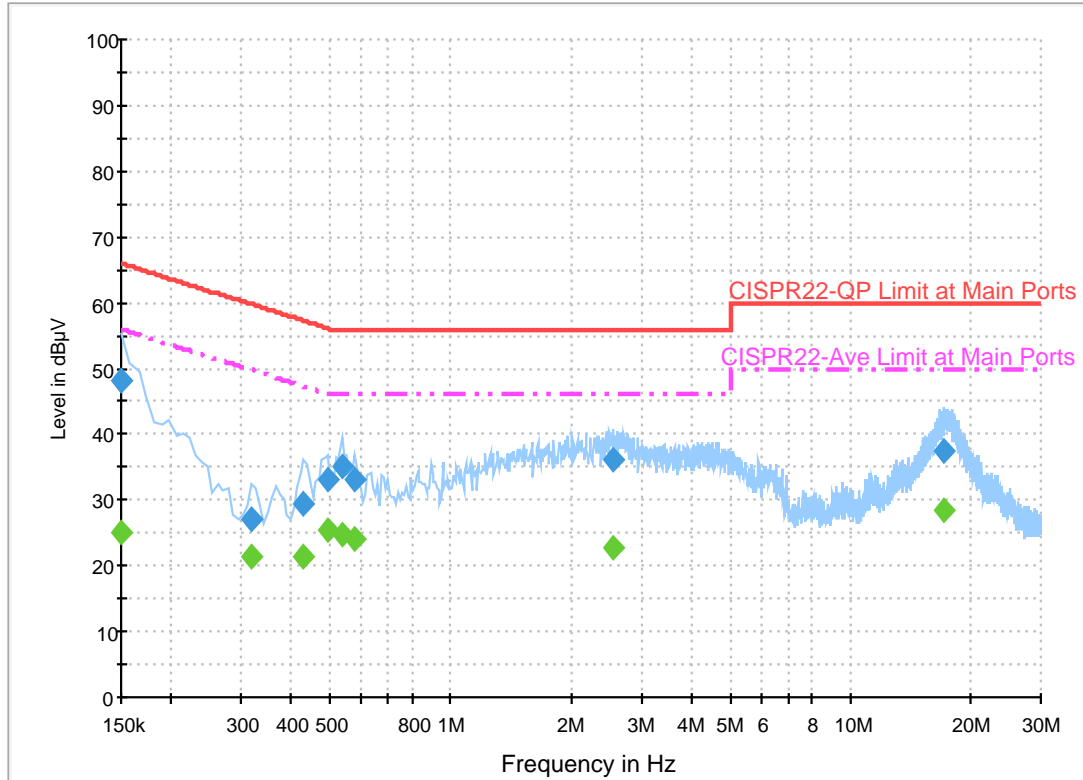

## Final Result 1

Frequency (MHz)	QuasiPeak (dBµV)	Filter	Line	Corr. (dB)	Margin (dB)	Limit (dBµV)
0.150000	48.3	Off	N	19.5	17.7	66.0
0.318000	27.2	Off	N	19.5	32.6	59.8
0.430000	29.4	Off	N	19.5	27.9	57.3
0.494000	33.0	Off	N	19.5	23.1	56.1
0.534000	35.2	Off	N	19.5	20.8	56.0
0.574000	33.1	Off	N	19.5	22.9	56.0
2.558000	36.1	Off	N	19.5	19.9	56.0
17.078000	37.4	Off	N	19.8	22.6	60.0

## Final Result 2

Frequency (MHz)	Average (dBµV)	Filter	Line	Corr. (dB)	Margin (dB)	Limit (dBµV)
0.150000	25.1	Off	N	19.5	30.9	56.0
0.318000	21.5	Off	N	19.5	28.3	49.8
0.430000	21.5	Off	N	19.5	25.8	47.3
0.494000	25.6	Off	N	19.5	20.5	46.1
0.534000	24.7	Off	N	19.5	21.3	46.0
0.574000	24.0	Off	N	19.5	22.0	46.0
2.558000	22.6	Off	N	19.5	23.4	46.0
17.078000	28.6	Off	N	19.8	21.4	50.0



## Appendix C. Radiated Spurious Emission

Test Engineer :	Lance Chiang and Yun Huang	Temperature :	22~24°C
		Relative Humidity :	52~58%

### Band 1 - 5150~5250MHz

#### WIFI 802.11a (Band Edge @ 3m)

WIFI	Note	Frequency	Level	Over	Limit	Read	Antenna	Cable	Preamp	Ant	Table	Peak	Pol.	
Ant.				Limit	Line	Level	Factor	Loss	Factor	Pos	Pos	Avg.		
1		( MHz )	( dBμV/m )	( dB )	( dBμV/m )	( dBμV )	( dB/m )	( dB )	( dB )	( cm )	( deg )	( P/A )	( H/V )	
802.11a CH 36 5180MHz		5148.98	67.54	-6.46	74	59.96	31.68	8.38	32.48	100	311	P	H	
		5149.5	50.15	-3.85	54	42.57	31.68	8.38	32.48	100	311	A	H	
	*	5180	108.9	-	-	101.27	31.72	8.39	32.48	100	311	P	H	
	*	5180	100.74	-	-	93.11	31.72	8.39	32.48	100	311	A	H	
													H	
														H
			5149.5	53.49	-20.51	74	45.91	31.68	8.38	32.48	100	353	P	V
			5150	46.04	-7.96	54	38.46	31.68	8.38	32.48	100	353	A	V
	*		5180	104.15	-	-	96.52	31.72	8.39	32.48	100	353	P	V
	*		5180	96.22	-	-	88.59	31.72	8.39	32.48	100	353	A	V
														V
														V
802.11a CH 44 5220MHz		5123.24	48.74	-25.26	74	41.2	31.66	8.36	32.48	107	310	P	H	
		5035.36	40.94	-13.06	54	33.54	31.54	8.33	32.47	107	310	A	H	
	*	5220	110.51	-	-	102.86	31.76	8.37	32.48	107	310	P	H	
	*	5220	101.53	-	-	93.88	31.76	8.37	32.48	107	310	A	H	
			5367.32	47.01	-26.99	74	39.45	31.94	8.11	32.49	107	310	P	H
			5418	39.14	-14.86	54	31.54	32	8.1	32.5	107	310	A	H
			5126.88	48.19	-25.81	74	40.64	31.66	8.37	32.48	100	353	P	V
			5117	39.81	-14.19	54	32.29	31.64	8.36	32.48	100	353	A	V
	*		5220	103.75	-	-	96.1	31.76	8.37	32.48	100	353	P	V
	*		5220	96.22	-	-	88.57	31.76	8.37	32.48	100	353	A	V
			5377.68	47.01	-26.99	74	39.46	31.96	8.08	32.49	100	353	P	V
			5414.64	38.7	-15.3	54	31.1	32	8.1	32.5	100	353	A	V



<b>802.11a CH 48 5240MHz</b>		5043.68	49.32	-24.68	74	41.9	31.56	8.33	32.47	100	309	P	H
		5044.98	40.83	-13.17	54	33.41	31.56	8.33	32.47	100	309	A	H
	*	5240	108.52	-	-	100.88	31.78	8.34	32.48	100	309	P	H
	*	5240	100.94	-	-	93.3	31.78	8.34	32.48	100	309	A	H
		5428.36	47.07	-26.93	74	39.47	32	8.1	32.5	100	309	P	H
		5428.08	39.3	-14.7	54	31.7	32	8.1	32.5	100	309	A	H
		5117	48.63	-25.37	74	41.11	31.64	8.36	32.48	100	352	P	V
		5139.62	39.72	-14.28	54	32.15	31.68	8.37	32.48	100	352	A	V
	*	5240	103.96	-	-	96.32	31.78	8.34	32.48	100	352	P	V
	*	5240	96.33	-	-	88.69	31.78	8.34	32.48	100	352	A	V
		5353.88	46.86	-27.14	74	39.28	31.92	8.15	32.49	100	352	P	V
		5438.16	38.81	-15.19	54	31.14	32.02	8.15	32.5	100	352	A	V

**Remark**

1. No other spurious found.
2. All results are PASS against Peak and Average limit line.



**Band 1 5150~5250MHz**  
**WIFI 802.11a (Harmonic @ 3m)**

WIFI Ant. 1	Note	Frequency ( MHz )	Level ( dBμV/m )	Over Limit ( dB )	Limit Line ( dBμV/m )	Read Level ( dBμV )	Antenna Factor ( dB/m )	Cable Loss ( dB )	Preamp Factor ( dB )	Ant Pos ( cm )	Table Pos ( deg )	Peak Avg. ( P/A )	Pol. ( H/V )
802.11a CH 36 5180MHz		10360	43.55	-30.45	74	57.48	39.49	11.78	65.2	100	0	P	H
		15540	43.22	-30.78	74	53.31	38.32	15.57	63.98	100	0	P	H
													H
													H
		10360	46.32	-27.68	74	60.25	39.49	11.78	65.2	100	0	P	V
		15540	43.3	-30.7	74	53.39	38.32	15.57	63.98	100	0	P	V
													V
													V
802.11a CH 44 5220MHz		10440	44.91	-29.09	74	58.68	39.59	11.84	65.2	100	0	P	H
		15660	43.75	-30.25	74	54.3	38.06	15.63	64.24	100	0	P	H
													H
													H
		10440	47.43	-26.57	74	61.2	39.59	11.84	65.2	100	0	P	V
		15660	43.18	-30.82	74	53.73	38.06	15.63	64.24	100	0	P	V
													V
													V
802.11a CH 48 5240MHz		10480	44.15	-29.85	74	57.79	39.67	11.89	65.2	100	0	P	H
		15720	42.69	-31.31	74	53.51	37.91	15.66	64.39	100	0	P	H
													H
													H
		10480	46.86	-27.14	74	60.5	39.67	11.89	65.2	100	0	P	V
		15720	43.81	-30.19	74	54.63	37.91	15.66	64.39	100	0	P	V
													V
													V
<b>Remark</b>	1. No other spurious found. 2. All results are PASS against Peak and Average limit line.												



**Band 1 5150~5250MHz**  
**WIFI 802.11n HT20 (Band Edge @ 3m)**

WIFI Ant. 1	Note	Frequency ( MHz )	Level ( dBμV/m )	Over Limit ( dB )	Limit Line ( dBμV/m )	Read Level ( dBμV )	Antenna Factor ( dB/m )	Cable Loss ( dB )	Preamp Factor ( dB )	Ant Pos ( cm )	Table Pos ( deg )	Peak Avg. ( P/A )	Pol. ( H/V )	
802.11n HT20 CH 36 5180MHz		5128.18	49.48	-24.52	74	41.93	31.66	8.37	32.48	100	242	P	H	
		5128.44	43.86	-10.14	54	36.31	31.66	8.37	32.48	100	242	A	H	
	*	5180	104.19	-	-	96.56	31.72	8.39	32.48	100	242	P	H	
	*	5180	93.03	-	-	85.4	31.72	8.39	32.48	100	242	A	H	
													H	
													H	
			5115.44	49.24	-24.76	74	41.72	31.64	8.36	32.48	400	20	P	V
			5148.46	40.4	-13.6	54	32.82	31.68	8.38	32.48	400	20	A	V
		*	5180	100.92	-	-	93.29	31.72	8.39	32.48	400	20	P	V
		*	5180	89.91	-	-	82.28	31.72	8.39	32.48	400	20	A	V
													V	
													V	
802.11n HT20 CH 44 5220MHz		5109.98	49.76	-24.24	74	42.24	31.64	8.36	32.48	100	243	P	H	
		5119.86	40.04	-13.96	54	32.52	31.64	8.36	32.48	100	243	A	H	
	*	5220	104.77	-	-	97.12	31.76	8.37	32.48	100	243	P	H	
	*	5220	93.22	-	-	85.57	31.76	8.37	32.48	100	243	A	H	
			5370.68	47.58	-26.42	74	40.02	31.94	8.11	32.49	100	243	P	H
			5405.68	39.28	-14.72	54	31.75	31.98	8.05	32.5	100	243	A	H
			5029.38	48.79	-25.21	74	41.39	31.54	8.33	32.47	100	293	P	V
			5069.42	39.87	-14.13	54	32.42	31.58	8.34	32.47	100	293	A	V
		*	5220	98.19	-	-	90.54	31.76	8.37	32.48	100	293	P	V
		*	5220	87.18	-	-	79.53	31.76	8.37	32.48	100	293	A	V
		5436.76	48.19	-25.81	74	40.52	32.02	8.15	32.5	100	293	P	V	
		5409.88	39.04	-14.96	54	31.51	31.98	8.05	32.5	100	293	A	V	



<b>802.11n</b>  <b>HT20</b>  <b>CH 48</b>  <b>5240MHz</b>		5100.36	48.59	-25.41	74	41.09	31.62	8.36	32.48	100	244	P	H
		5053.04	40.03	-13.97	54	32.6	31.56	8.34	32.47	100	244	A	H
	*	5240	102.78	-	-	95.14	31.78	8.34	32.48	100	244	P	H
	*	5240	91.71	-	-	84.07	31.78	8.34	32.48	100	244	A	H
		5446.84	47.65	-26.35	74	39.96	32.04	8.15	32.5	100	244	P	H
		5437.32	39.54	-14.46	54	31.87	32.02	8.15	32.5	100	244	A	H
		5010.66	47.77	-26.23	74	40.4	31.52	8.32	32.47	381	205	P	V
		5102.96	39.86	-14.14	54	32.36	31.62	8.36	32.48	381	205	A	V
	*	5240	97.8	-	-	90.16	31.78	8.34	32.48	381	205	P	V
	*	5240	87.62	-	-	79.98	31.78	8.34	32.48	381	205	A	V
		5430.88	49.07	-24.93	74	41.4	32.02	8.15	32.5	381	205	P	V
		5445.72	38.99	-15.01	54	31.3	32.04	8.15	32.5	381	205	A	V
<b>Remark</b>	1. No other spurious found. 2. All results are PASS against Peak and Average limit line.												



**Band 1 5150~5250MHz**  
**WIFI 802.11n HT20 (Harmonic @ 3m)**

WIFI Ant. 1	Note	Frequency ( MHz )	Level ( dBμV/m )	Over Limit ( dB )	Limit Line ( dBμV/m )	Read Level ( dBμV )	Antenna Factor ( dB/m )	Cable Loss ( dB )	Preamp Factor ( dB )	Ant Pos ( cm )	Table Pos ( deg )	Peak Avg. ( P/A )	Pol. ( H/V )
802.11n HT20 CH 36 5180MHz		10360	44.32	-29.68	74	58.25	39.49	11.78	65.2	100	0	P	H
		15540	44.06	-29.94	74	54.15	38.32	15.57	63.98	100	0	P	H
													H
													H
		10360	44.71	-29.29	74	58.64	39.49	11.78	65.2	100	0	P	V
		15540	44.01	-29.99	74	54.1	38.32	15.57	63.98	100	0	P	V
													V
802.11n HT20 CH 44 5220MHz		10440	44.82	-29.18	74	58.59	39.59	11.84	65.2	100	0	P	H
		15660	42.92	-31.08	74	53.47	38.06	15.63	64.24	100	0	P	H
													H
													H
		10440	45.34	-28.66	74	59.11	39.59	11.84	65.2	100	0	P	V
		15660	42.96	-31.04	74	53.51	38.06	15.63	64.24	100	0	P	V
													V
802.11n HT20 CH 48 5240MHz		10480	44.77	-29.23	74	58.41	39.67	11.89	65.2	100	0	P	H
		15720	43.07	-30.93	74	53.89	37.91	15.66	64.39	100	0	P	H
													H
													H
		10480	46.29	-27.71	74	59.93	39.67	11.89	65.2	100	0	P	V
		15720	43.09	-30.91	74	53.91	37.91	15.66	64.39	100	0	P	V
													V
Remark	1. No other spurious found.												
	2. All results are PASS against Peak and Average limit line.												



**Band 1 5150~5250MHz**  
**WIFI 802.11n HT40 (Band Edge @ 3m)**

WIFI Ant. 1	Note	Frequency ( MHz )	Level ( dBμV/m )	Over Limit ( dB )	Limit Line ( dBμV/m )	Read Level ( dBμV )	Antenna Factor ( dB/m )	Cable Loss ( dB )	Preamp Factor ( dB )	Ant Pos ( cm )	Table Pos ( deg )	Peak Avg. ( P/A )	Pol. ( H/V )	
802.11n HT40 CH 38 5190MHz		5149.24	57.41	-16.59	74	49.83	31.68	8.38	32.48	100	242	P	H	
		5149.24	50.19	-3.81	54	42.61	31.68	8.38	32.48	100	242	A	H	
	*	5190	100.73	-	-	93.1	31.72	8.39	32.48	100	242	P	H	
	*	5190	92.03	-	-	84.4	31.72	8.39	32.48	100	242	A	H	
		5441.8	47.79	-26.21	74	40.12	32.02	8.15	32.5	100	242	P	H	
		5447.12	39.09	-14.91	54	31.4	32.04	8.15	32.5	100	242	A	H	
		5146.12	56.63	-17.37	74	49.05	31.68	8.38	32.48	100	272	P	V	
		5149.76	48.48	-5.52	54	40.9	31.68	8.38	32.48	100	272	A	V	
	*	5190	98.23	-	-	90.6	31.72	8.39	32.48	100	272	P	V	
	*	5190	89.13	-	-	81.5	31.72	8.39	32.48	100	272	A	V	
		5432.56	47.3	-26.7	74	39.63	32.02	8.15	32.5	100	272	P	V	
		5459.72	39.13	-14.87	54	31.4	32.04	8.19	32.5	100	272	A	V	
	802.11n HT40 CH 46 5230MHz		5090.48	49.2	-24.8	74	41.69	31.62	8.36	32.47	100	243	P	H
			5126.88	40.69	-13.31	54	33.14	31.66	8.37	32.48	100	243	A	H
*		5230	99.96	-	-	92.29	31.78	8.37	32.48	100	243	P	H	
*		5230	91.56	-	-	83.89	31.78	8.37	32.48	100	243	A	H	
		5434.8	47.01	-26.99	74	39.34	32.02	8.15	32.5	100	243	P	H	
		5435.92	39.18	-14.82	54	31.51	32.02	8.15	32.5	100	243	A	H	
		5147.16	49.63	-24.37	74	42.05	31.68	8.38	32.48	100	274	P	V	
		5126.62	40.34	-13.66	54	32.79	31.66	8.37	32.48	100	274	A	V	
*		5230	97.26	-	-	89.59	31.78	8.37	32.48	100	274	P	V	
*		5230	89.06	-	-	81.39	31.78	8.37	32.48	100	274	A	V	
	5411.56	47.24	-26.76	74	39.69	32	8.05	32.5	100	274	P	V		
	5439.28	39.01	-14.99	54	31.34	32.02	8.15	32.5	100	274	A	V		
Remark	1. No other spurious found. 2. All results are PASS against Peak and Average limit line.													





**Band 1 5150~5250MHz**  
**WIFI 802.11n HT40 (Harmonic @ 3m)**

WIFI Ant. 1	Note	Frequency ( MHz )	Level ( dBμV/m )	Over Limit ( dB )	Limit Line ( dBμV/m )	Read Level (dBμV)	Antenna Factor ( dB/m )	Cable Loss ( dB )	Preamp Factor ( dB )	Ant Pos ( cm )	Table Pos ( deg )	Peak Avg. (P/A)	Pol. (H/V)
802.11n HT40 CH 38 5190MHz		10380	44.6	-29.4	74	58.49	39.51	11.8	65.2	100	0	P	H
		15570	44.36	-29.64	74	54.57	38.25	15.59	64.05	100	0	P	H
													H
													H
		10380	44.6	-29.4	74	58.49	39.51	11.8	65.2	100	0	P	V
		15570	43.98	-30.02	74	54.19	38.25	15.59	64.05	100	0	P	V
													V
													V
802.11n HT40 CH 46 5230MHz		10460	43.89	-30.11	74	57.61	39.62	11.86	65.2	100	0	P	H
		15690	43.14	-30.86	74	53.84	37.98	15.64	64.32	100	0	P	H
													H
													H
		10460	45.36	-28.64	74	59.08	39.62	11.86	65.2	100	0	P	V
		15690	44.49	-29.51	74	55.19	37.98	15.64	64.32	100	0	P	V
													V
													V
<b>Remark</b>	1. No other spurious found. 2. All results are PASS against Peak and Average limit line.												



**Band 2 - 5250~5350MHz**  
**WIFI 802.11a (Band Edge @ 3m)**

WIFI	Note	Frequency	Level	Over	Limit	Read	Antenna	Cable	Preamp	Ant	Table	Peak	Pol.
Ant.				Limit	Line	Level	Factor	Loss	Factor	Pos	Pos	Avg.	
1		( MHz )	( dBμV/m )	( dB )	( dBμV/m )	( dBμV )	( dB/m )	( dB )	( dB )	( cm )	( deg )	( P/A )	( H/V )
802.11a CH 52 5260MHz		5047.26	48.76	-25.24	74	41.34	31.56	8.33	32.47	106	270	P	H
		5075.48	40.51	-13.49	54	33.03	31.6	8.35	32.47	106	270	A	H
	*	5260	108.06	-	-	100.43	31.82	8.3	32.49	106	270	P	H
	*	5260	100.38	-	-	92.75	31.82	8.3	32.49	106	270	A	H
		5446.08	46.89	-27.11	74	39.2	32.04	8.15	32.5	106	270	P	H
		5449.44	39.8	-14.2	54	32.07	32.04	8.19	32.5	106	270	A	H
		5029.92	48.5	-25.5	74	41.1	31.54	8.33	32.47	100	351	P	V
		5074.46	39.61	-14.39	54	32.13	31.6	8.35	32.47	100	351	A	V
	*	5260	102.53	-	-	94.9	31.82	8.3	32.49	100	351	P	V
	*	5260	94.89	-	-	87.26	31.82	8.3	32.49	100	351	A	V
		5396.4	46.22	-27.78	74	38.68	31.98	8.05	32.49	100	351	P	V
		5448.72	38.86	-15.14	54	31.13	32.04	8.19	32.5	100	351	A	V
802.11a CH 60 5300MHz		5087.72	49.09	-24.91	74	41.61	31.6	8.35	32.47	107	269	P	H
		5108.8	40.65	-13.35	54	33.13	31.64	8.36	32.48	107	269	A	H
	*	5300	108.54	-	-	100.93	31.86	8.24	32.49	107	269	P	H
	*	5300	99.99	-	-	92.38	31.86	8.24	32.49	107	269	A	H
		5352.72	52.92	-21.08	74	45.34	31.92	8.15	32.49	107	269	P	H
		5352.24	45.71	-8.29	54	38.13	31.92	8.15	32.49	107	269	A	H
		5107.44	48.8	-25.2	74	41.28	31.64	8.36	32.48	100	352	P	V
		5100.64	39.76	-14.24	54	32.26	31.62	8.36	32.48	100	352	A	V
	*	5300	101.85	-	-	94.24	31.86	8.24	32.49	100	352	P	V
	*	5300	94.27	-	-	86.66	31.86	8.24	32.49	100	352	A	V
		5353.2	48.96	-25.04	74	41.38	31.92	8.15	32.49	100	352	P	V
		5352.24	41.34	-12.66	54	33.76	31.92	8.15	32.49	100	352	A	V



<b>802.11a</b>  <b>CH 64</b>  <b>5320MHz</b>	*	5320	108.48	-	-	100.88	31.88	8.21	32.49	100	271	P	H
	*	5320	100.03	-	-	92.43	31.88	8.21	32.49	100	271	A	H
		5350.4	61.14	-12.86	74	53.56	31.92	8.15	32.49	100	271	P	H
		5350.24	50.08	-3.92	54	42.5	31.92	8.15	32.49	100	271	A	H
													H
													H
	*	5320	101.78	-	-	94.18	31.88	8.21	32.49	100	352	P	V
	*	5320	94.32	-	-	86.72	31.88	8.21	32.49	100	352	A	V
		5353.6	51.86	-22.14	74	44.28	31.92	8.15	32.49	100	352	P	V
		5350.24	44.62	-9.38	54	37.04	31.92	8.15	32.49	100	352	A	V
													V
													V
<b>Remark</b>	1. No other spurious found. 2. All results are PASS against Peak and Average limit line.												



**Band 2 5250~5350MHz**  
**WIFI 802.11a (Harmonic @ 3m)**

WIFI Ant. 1	Note	Frequency ( MHz )	Level ( dBμV/m )	Over Limit ( dB )	Limit Line ( dBμV/m )	Read Level ( dBμV )	Antenna Factor ( dB/m )	Cable Loss ( dB )	Preamp Factor ( dB )	Ant Pos ( cm )	Table Pos ( deg )	Peak Avg. ( P/A )	Pol. ( H/V )
802.11a CH 52 5260MHz		10520	44.38	-29.62	74	57.95	39.71	11.92	65.2	100	0	P	H
		15780	42.24	-31.76	74	53.27	37.79	15.69	64.51	100	0	P	H
													H
													H
		10520	46.65	-27.35	74	60.22	39.71	11.92	65.2	100	0	P	V
		15780	42.25	-31.75	74	53.28	37.79	15.69	64.51	100	0	P	V
													V
													V
802.11a CH 60 5300MHz		10600	44.65	-29.35	74	58.07	39.78	11.98	65.18	100	0	P	H
		15900	42.45	-31.55	74	53.94	37.53	15.75	64.77	100	0	P	H
													H
													H
		10600	46.86	-27.14	74	60.28	39.78	11.98	65.18	100	0	P	V
		15900	41.21	-32.79	74	52.7	37.53	15.75	64.77	100	0	P	V
													V
													V
802.11a CH 64 5320MHz		10640	44.95	-29.05	74	58.3	39.81	12.01	65.17	100	0	P	H
		15960	42.52	-31.48	74	54.28	37.38	15.78	64.92	100	0	P	H
													H
													H
		10640	44.73	-29.27	74	58.08	39.81	12.01	65.17	100	0	P	V
		15960	41.73	-32.27	74	53.49	37.38	15.78	64.92	100	0	P	V
													V
													V
<b>Remark</b>	1. No other spurious found. 2. All results are PASS against Peak and Average limit line.												



**Band 2 5250~5350MHz**  
**WIFI 802.11n HT20 (Band Edge @ 3m)**

WIFI Ant. 1	Note	Frequency ( MHz )	Level ( dBµV/m )	Over Limit ( dB )	Limit Line ( dBµV/m )	Read Level ( dBµV )	Antenna Factor ( dB/m )	Cable Loss ( dB )	Preamp Factor ( dB )	Ant Pos ( cm )	Table Pos ( deg )	Peak Avg. ( P/A )	Pol. ( H/V )
802.11n HT20 CH 52 5260MHz		5113.9	47.81	-26.19	74	40.29	31.64	8.36	32.48	100	252	P	H
		5075.82	40.29	-13.71	54	32.81	31.6	8.35	32.47	100	252	A	H
	*	5260	102.14	-	-	94.51	31.82	8.3	32.49	100	252	P	H
	*	5260	94.84	-	-	87.21	31.82	8.3	32.49	100	252	A	H
		5459.28	47.9	-26.1	74	40.17	32.04	8.19	32.5	100	252	P	H
		5454.48	39.51	-14.49	54	31.78	32.04	8.19	32.5	100	252	A	H
		5131.58	48.66	-25.34	74	41.11	31.66	8.37	32.48	142	292	P	V
		5047.94	39.95	-14.05	54	32.53	31.56	8.33	32.47	142	292	A	V
	*	5260	97.84	-	-	90.21	31.82	8.3	32.49	142	292	P	V
	*	5260	90.24	-	-	82.61	31.82	8.3	32.49	142	292	A	V
		5453.52	46.88	-27.12	74	39.15	32.04	8.19	32.5	142	292	P	V
		5458.56	39.13	-14.87	54	31.4	32.04	8.19	32.5	142	292	A	V
802.11n HT20 CH 60 5300MHz		5066.3	49.81	-24.19	74	42.36	31.58	8.34	32.47	100	253	P	H
		5115.94	40.08	-13.92	54	32.56	31.64	8.36	32.48	100	253	A	H
	*	5300	102.01	-	-	94.4	31.86	8.24	32.49	100	253	P	H
	*	5300	94.51	-	-	86.9	31.86	8.24	32.49	100	253	A	H
		5353.44	48.53	-25.47	74	40.95	31.92	8.15	32.49	100	253	P	H
		5351.76	42.31	-11.69	54	34.73	31.92	8.15	32.49	100	253	A	H
		5125.46	48.38	-25.62	74	40.83	31.66	8.37	32.48	100	291	P	V
		5115.26	39.85	-14.15	54	32.33	31.64	8.36	32.48	100	291	A	V
	*	5300	98.11	-	-	90.5	31.86	8.24	32.49	100	291	P	V
	*	5300	90.81	-	-	83.2	31.86	8.24	32.49	100	291	A	V
	5351.52	48.23	-25.77	74	40.65	31.92	8.15	32.49	100	291	P	V	
	5351.76	40.68	-13.32	54	33.1	31.92	8.15	32.49	100	291	A	V	



<b>802.11n</b> <b>HT20</b> <b>CH 64</b> <b>5320MHz</b>	*	5320	103.1	-	-	95.5	31.88	8.21	32.49	100	245	P	H
	*	5320	94.5	-	-	86.9	31.88	8.21	32.49	100	245	A	H
		5371.2	49	-25	74	41.44	31.94	8.11	32.49	100	245	P	H
		5371.68	43.03	-10.97	54	35.47	31.94	8.11	32.49	100	245	A	H
													H
													H
	*	5320	98.7	-	-	91.1	31.88	8.21	32.49	100	292	P	V
	*	5320	90.9	-	-	83.3	31.88	8.21	32.49	100	292	A	V
		5371.2	47.84	-26.16	74	40.28	31.94	8.11	32.49	100	292	P	V
		5372	40.75	-13.25	54	33.19	31.94	8.11	32.49	100	292	A	V
													V
													V
<b>Remark</b>	1. No other spurious found. 2. All results are PASS against Peak and Average limit line.												



**Band 2 5250~5350MHz**  
**WIFI 802.11n HT20 (Harmonic @ 3m)**

WIFI Ant. 1	Note	Frequency ( MHz )	Level ( dBμV/m )	Over Limit ( dB )	Limit Line ( dBμV/m )	Read Level ( dBμV )	Antenna Factor ( dB/m )	Cable Loss ( dB )	Preamp Factor ( dB )	Ant Pos ( cm )	Table Pos ( deg )	Peak Avg. ( P/A )	Pol. ( H/V )	
802.11n HT20 CH 52 5260MHz		10520	44.46	-29.54	74	58.03	39.71	11.92	65.2	100	0	P	H	
		15780	42.45	-31.55	74	53.48	37.79	15.69	64.51	100	0	P	H	
													H	
													H	
			10520	46.61	-27.39	74	60.18	39.71	11.92	65.2	100	0	P	V
			15780	42.73	-31.27	74	53.76	37.79	15.69	64.51	100	0	P	V
														V
802.11n HT20 CH 60 5300MHz		10600	45.89	-28.11	74	59.31	39.78	11.98	65.18	100	0	P	H	
		15900	43	-31	74	54.49	37.53	15.75	64.77	100	0	P	H	
													H	
													H	
			10600	45.76	-28.24	74	59.18	39.78	11.98	65.18	100	0	P	V
			15900	41.96	-32.04	74	53.45	37.53	15.75	64.77	100	0	P	V
														V
802.11n HT20 CH 64 5320MHz		10640	44.63	-29.37	74	57.98	39.81	12.01	65.17	100	0	P	H	
		15960	42.64	-31.36	74	54.4	37.38	15.78	64.92	100	0	P	H	
													H	
													H	
			10640	45.1	-28.9	74	58.45	39.81	12.01	65.17	100	0	P	V
			15960	42.44	-31.56	74	54.2	37.38	15.78	64.92	100	0	P	V
														V
Remark	1. No other spurious found.													
	2. All results are PASS against Peak and Average limit line.													



**Band 2 5250~5350MHz**  
**WIFI 802.11n HT40 (Band Edge @ 3m)**

WIFI Ant. 1	Note	Frequency ( MHz )	Level ( dBμV/m )	Over Limit ( dB )	Limit Line ( dBμV/m )	Read Level ( dBμV )	Antenna Factor ( dB/m )	Cable Loss ( dB )	Preamp Factor ( dB )	Ant Pos ( cm )	Table Pos ( deg )	Peak Avg. ( P/A )	Pol. ( H/V )
802.11n HT40 CH 54 5270MHz		5086.36	48.35	-25.65	74	40.87	31.6	8.35	32.47	100	251	P	H
		5093.16	39.84	-14.16	54	32.34	31.62	8.36	32.48	100	251	A	H
	*	5270	98.41	-	-	90.81	31.82	8.27	32.49	100	251	P	H
	*	5270	89.81	-	-	82.21	31.82	8.27	32.49	100	251	A	H
		5408.64	47.02	-26.98	74	39.49	31.98	8.05	32.5	100	251	P	H
		5374.56	39.32	-14.68	54	31.76	31.94	8.11	32.49	100	251	A	H
		5079.22	49.18	-24.82	74	41.7	31.6	8.35	32.47	100	273	P	V
		5142.12	39.76	-14.24	54	32.19	31.68	8.37	32.48	100	273	A	V
	*	5270	95.51	-	-	87.91	31.82	8.27	32.49	100	273	P	V
	*	5270	86.81	-	-	79.21	31.82	8.27	32.49	100	273	A	V
		5413.44	47.51	-26.49	74	39.91	32	8.1	32.5	100	273	P	V
		5372.88	38.98	-15.02	54	31.42	31.94	8.11	32.49	100	273	A	V
	802.11n HT40 CH 62 5310MHz		5102	49.21	-24.79	74	41.71	31.62	8.36	32.48	100	244	P
		5103.7	39.74	-14.26	54	32.24	31.62	8.36	32.48	100	244	A	H
*		5310	99	-	-	91.4	31.88	8.21	32.49	100	244	P	H
*		5310	91	-	-	83.4	31.88	8.21	32.49	100	244	A	H
		5351.52	57.63	-16.37	74	50.05	31.92	8.15	32.49	100	244	P	H
		5350.08	49.71	-4.29	54	42.13	31.92	8.15	32.49	100	244	A	H
		5026.52	48.7	-25.3	74	41.3	31.54	8.33	32.47	100	289	P	V
		5122.74	39.74	-14.26	54	32.2	31.66	8.36	32.48	100	289	A	V
*		5310	95.5	-	-	87.9	31.88	8.21	32.49	100	289	P	V
*		5310	87.4	-	-	79.8	31.88	8.21	32.49	100	289	A	V
	5353.2	50.08	-23.92	74	42.5	31.92	8.15	32.49	100	289	P	V	
	5350.56	45.71	-8.29	54	38.13	31.92	8.15	32.49	100	289	A	V	
<b>Remark</b>	1. No other spurious found. 2. All results are PASS against Peak and Average limit line.												





**Band 2 5250~5350MHz**  
**WIFI 802.11n HT40 (Harmonic @ 3m)**

WIFI Ant. 1	Note	Frequency ( MHz )	Level ( dBμV/m )	Over Limit ( dB )	Limit Line ( dBμV/m )	Read Level (dBμV)	Antenna Factor ( dB/m )	Cable Loss ( dB )	Preamp Factor ( dB )	Ant Pos ( cm )	Table Pos ( deg )	Peak Avg. (P/A)	Pol. (H/V)
802.11n HT40 CH 54 5270MHz		10540	43.7	-30.3	74	57.23	39.73	11.93	65.19	100	0	P	H
		15810	42.4	-31.6	74	53.55	37.72	15.71	64.58	100	0	P	H
													H
													H
		10540	44.71	-29.29	74	58.24	39.73	11.93	65.19	100	0	P	V
		15810	43.83	-30.17	74	54.98	37.72	15.71	64.58	100	0	P	V
													V
													V
802.11n HT40 CH 62 5310MHz		10620	44.9	-29.1	74	58.29	39.8	11.99	65.18	100	0	P	H
		15930	41.8	-32.2	74	53.43	37.45	15.77	64.85	100	0	P	H
													H
													H
		10620	46.23	-27.77	74	59.62	39.8	11.99	65.18	100	0	P	V
		15930	41.09	-32.91	74	52.72	37.45	15.77	64.85	100	0	P	V
													V
													V
<b>Remark</b>	1. No other spurious found. 2. All results are PASS against Peak and Average limit line.												



**Band 3 - 5470~5725MHz**  
**WIFI 802.11a (Band Edge @ 3m)**

WIFI	Note	Frequency	Level	Over	Limit	Read	Antenna	Cable	Preamp	Ant	Table	Peak	Pol.	
Ant.				Limit	Line	Level	Factor	Loss	Factor	Pos	Pos	Avg.		
1		( MHz )	( dBμV/m )	( dB )	( dBμV/m )	( dBμV )	( dB/m )	( dB )	( dB )	( cm )	( deg )	( P/A )	( H/V )	
802.11a CH 100 5500MHz		5469.52	56.2	-17.8	74	48.4	32.06	8.24	32.5	107	241	P	H	
		5469.68	48.72	-5.28	54	40.92	32.06	8.24	32.5	107	241	A	H	
	*	5500	107.23	-	-	99.34	32.1	8.29	32.5	107	241	P	H	
	*	5500	99.55	-	-	91.66	32.1	8.29	32.5	107	241	A	H	
													H	
													H	
			5467.6	51.25	-22.75	74	43.45	32.06	8.24	32.5	106	304	P	V
			5470	43.57	-10.43	54	35.77	32.06	8.24	32.5	106	304	A	V
	*		5500	102.19	-	-	94.3	32.1	8.29	32.5	106	304	P	V
	*		5500	94	-	-	86.11	32.1	8.29	32.5	106	304	A	V
													V	
													V	
802.11a CH 116 5580MHz		5440.48	47.41	-26.59	74	39.74	32.02	8.15	32.5	100	242	P	H	
		5384.56	39.23	-14.77	54	31.68	31.96	8.08	32.49	100	242	A	H	
	*	5580	106.38	-	-	98.22	32.17	8.53	32.54	100	242	P	H	
	*	5580	98.73	-	-	90.57	32.17	8.53	32.54	100	242	A	H	
			5753.03	48.6	-25.4	74	39.76	32.36	9.07	32.59	100	242	P	H
			5765	40.5	-13.5	54	31.6	32.36	9.14	32.6	100	242	A	H
			5405.2	47.17	-26.83	74	39.64	31.98	8.05	32.5	100	303	P	V
			5463.52	38.92	-15.08	54	31.17	32.06	8.19	32.5	100	303	A	V
	*		5580	101.17	-	-	93.01	32.17	8.53	32.54	100	303	P	V
	*		5580	93.34	-	-	85.18	32.17	8.53	32.54	100	303	A	V
			5755.55	48.49	-25.51	74	39.58	32.36	9.14	32.59	100	303	P	V
			5759.645	40.16	-13.84	54	31.26	32.36	9.14	32.6	100	303	A	V



<b>802.11a</b> <b>CH 140</b> <b>5700MHz</b>	*	5700	106.41	-	-	97.74	32.29	8.95	32.57	111	312	P	H
	*	5700	98.86	-	-	90.19	32.29	8.95	32.57	111	312	A	H
		5727.8	61.99	-6.21	68.2	53.24	32.32	9.01	32.58	111	312	P	H
													H
													H
													H
	*	5700	101.83	-	-	93.16	32.29	8.95	32.57	100	323	P	V
	*	5700	93.25	-	-	84.58	32.29	8.95	32.57	100	323	A	V
		5725.88	59.7	-8.5	68.2	50.95	32.32	9.01	32.58	100	323	P	V
													V
													V
													V
<b>Remark</b>	1. No other spurious found. 2. All results are PASS against Peak and Average limit line.												



**Band 3 - 5470~5725MHz**  
**WIFI 802.11a (Harmonic @ 3m)**

WIFI Ant. 1	Note	Frequency ( MHz )	Level ( dBµV/m )	Over Limit ( dB )	Limit Line ( dBµV/m )	Read Level ( dBµV )	Antenna Factor ( dB/m )	Cable Loss ( dB )	Preamp Factor ( dB )	Ant Pos ( cm )	Table Pos ( deg )	Peak Avg. ( P/A )	Pol. ( H/V )
802.11a CH 100 5500MHz		11000	44.72	-29.28	74	57.41	40.1	12.31	65.1	100	0	P	H
		16500	43.55	-30.45	74	53.65	38.8	16.2	65.1	100	0	P	H
													H
													H
		11000	46.89	-27.11	74	59.58	40.1	12.31	65.1	100	0	P	V
		16500	45.01	-28.99	74	55.11	38.8	16.2	65.1	100	0	P	V
													V
													V
802.11a CH 116 5580MHz		11160	45.89	-28.11	74	58.64	40	12.45	65.2	100	0	P	H
		16740	43.15	-30.85	74	52.3	39.33	16.38	64.86	100	0	P	H
													H
													H
		11160	46.86	-27.14	74	59.61	40	12.45	65.2	100	0	P	V
		16740	43.46	-30.54	74	52.61	39.33	16.38	64.86	100	0	P	V
													V
													V
802.11a CH 140 5700MHz		11400	44.99	-29.01	74	57.81	39.86	12.66	65.34	100	0	P	H
		17100	46.08	-22.12	68.2	53.5	40.38	16.66	64.46	100	0	P	H
													H
													H
		11400	48.16	-25.84	74	60.98	39.86	12.66	65.34	100	0	P	V
		17100	46.95	-21.25	68.2	54.37	40.38	16.66	64.46	100	0	P	V
													V
													V
Remark	1. No other spurious found. 2. All results are PASS against Peak and Average limit line.												



**Band 3 - 5470~5725MHz**  
**WIFI 802.11n HT20 (Band Edge @ 3m)**

WIFI Ant. 1	Note	Frequency ( MHz )	Level ( dBμV/m )	Over Limit ( dB )	Limit Line ( dBμV/m )	Read Level ( dBμV )	Antenna Factor ( dB/m )	Cable Loss ( dB )	Preamp Factor ( dB )	Ant Pos ( cm )	Table Pos ( deg )	Peak Avg. ( P/A )	Pol. ( H/V )	
802.11n HT20 CH 100 5500MHz		5449.52	47.68	-26.32	74	39.95	32.04	8.19	32.5	100	239	P	H	
		5448.24	42.04	-11.96	54	34.31	32.04	8.19	32.5	100	239	A	H	
	*	5500	101.09	-	-	93.2	32.1	8.29	32.5	100	239	P	H	
	*	5500	92.99	-	-	85.1	32.1	8.29	32.5	100	239	A	H	
													H	
													H	
			5466.48	47.42	-26.58	74	39.62	32.06	8.24	32.5	100	276	P	V
			5448.24	40.51	-13.49	54	32.78	32.04	8.19	32.5	100	276	A	V
		*	5500	97.39	-	-	89.5	32.1	8.29	32.5	100	276	P	V
		*	5500	89.89	-	-	82	32.1	8.29	32.5	100	276	A	V
														V
														V
802.11n HT20 CH 116 5580MHz		5386.48	47.67	-26.33	74	40.12	31.96	8.08	32.49	100	246	P	H	
		5384.8	39.22	-14.78	54	31.67	31.96	8.08	32.49	100	246	A	H	
		* 5580	100.06	-	-	91.9	32.17	8.53	32.54	100	246	P	H	
		* 5580	92.36	-	-	84.2	32.17	8.53	32.54	100	246	A	H	
			5759.645	48.72	-25.28	74	39.82	32.36	9.14	32.6	100	246	P	H
			5764.055	40.38	-13.62	54	31.48	32.36	9.14	32.6	100	246	A	H
			5443.84	47.42	-26.58	74	39.75	32.02	8.15	32.5	100	292	P	V
			5454.64	39.09	-14.91	54	31.36	32.04	8.19	32.5	100	292	A	V
		*	5580	97.96	-	-	89.8	32.17	8.53	32.54	100	292	P	V
		*	5580	90.66	-	-	82.5	32.17	8.53	32.54	100	292	A	V
			5736.965	49	-25	74	40.18	32.34	9.07	32.59	100	292	P	V
			5764.685	40.39	-13.61	54	31.49	32.36	9.14	32.6	100	292	A	V



<b>802.11n</b> <b>HT20</b> <b>CH 140</b> <b>5700MHz</b>	*	5700	99.97	-	-	91.3	32.29	8.95	32.57	100	240	P	H
	*	5700	92.47	-	-	83.8	32.29	8.95	32.57	100	240	A	H
		5725.24	51.25	-22.75	74	42.5	32.32	9.01	32.58	100	240	P	H
		5725.08	44.24	-9.76	54	35.49	32.32	9.01	32.58	100	240	A	H
													H
													H
	*	5700	98.47	-	-	89.8	32.29	8.95	32.57	100	296	P	V
	*	5700	91.17	-	-	82.5	32.29	8.95	32.57	100	296	A	V
		5725.24	50.33	-23.67	74	41.58	32.32	9.01	32.58	100	296	P	V
		5725.16	43.28	-10.72	54	34.53	32.32	9.01	32.58	100	296	A	V
													V
													V
<b>Remark</b>	1. No other spurious found. 2. All results are PASS against Peak and Average limit line.												



**Band 3 - 5470~5725MHz**  
**WIFI 802.11n HT20 (Harmonic @ 3m)**

WIFI Ant. 1	Note	Frequency ( MHz )	Level ( dBμV/m )	Over Limit ( dB )	Limit Line ( dBμV/m )	Read Level ( dBμV )	Antenna Factor ( dB/m )	Cable Loss ( dB )	Preamp Factor ( dB )	Ant Pos ( cm )	Table Pos ( deg )	Peak Avg. ( P/A )	Pol. ( H/V )
802.11n HT20 CH 100 5500MHz		11000	46.02	-27.98	74	58.71	40.1	12.31	65.1	100	0	P	H
		16500	43.05	-30.95	74	53.15	38.8	16.2	65.1	100	0	P	H
													H
													H
		11000	46.13	-27.87	74	58.82	40.1	12.31	65.1	100	0	P	V
		16500	44.34	-29.66	74	54.44	38.8	16.2	65.1	100	0	P	V
													V
802.11n HT20 CH 116 5580MHz		11160	45.22	-28.78	74	57.97	40	12.45	65.2	100	0	P	H
		16740	43.13	-30.87	74	52.28	39.33	16.38	64.86	100	0	P	H
													H
													H
		11160	46.03	-27.97	74	58.78	40	12.45	65.2	100	0	P	V
		16740	43.69	-30.31	74	52.84	39.33	16.38	64.86	100	0	P	V
													V
802.11n HT20 CH 140 5700MHz		11400	44.64	-29.36	74	57.46	39.86	12.66	65.34	100	0	P	H
		17100	46.92	-27.08	74	54.34	40.38	16.66	64.46	100	0	P	H
													H
													H
		11400	48.71	-25.29	74	61.53	39.86	12.66	65.34	100	0	P	V
		17100	46.71	-27.29	74	54.13	40.38	16.66	64.46	100	0	P	V
													V
Remark	1. No other spurious found.												
	2. All results are PASS against Peak and Average limit line.												



**Band 3 - 5470~5725MHz**  
**WIFI 802.11n HT40 (Band Edge @ 3m)**

WIFI Ant. 1	Note	Frequency ( MHz )	Level ( dBμV/m )	Over Limit ( dB )	Limit Line ( dBμV/m )	Read Level ( dBμV )	Antenna Factor ( dB/m )	Cable Loss ( dB )	Preamp Factor ( dB )	Ant Pos ( cm )	Table Pos ( deg )	Peak Avg. ( P/A )	Pol. ( H/V )
802.11n HT40 CH 102 5510MHz		5466.64	51.91	-22.09	74	44.11	32.06	8.24	32.5	100	240	P	H
		5470	45.37	-8.63	54	37.57	32.06	8.24	32.5	100	240	A	H
	*	5510	97.03	-	-	89.1	32.1	8.34	32.51	100	240	P	H
	*	5510	89.23	-	-	81.3	32.1	8.34	32.51	100	240	A	H
		5749.25	49.22	-24.78	74	40.4	32.34	9.07	32.59	100	240	P	H
		5756.18	40.38	-13.62	54	31.48	32.36	9.14	32.6	100	240	A	H
		5469.52	50.02	-23.98	74	42.22	32.06	8.24	32.5	100	291	P	V
		5469.76	44.05	-9.95	54	36.25	32.06	8.24	32.5	100	291	A	V
	*	5510	94.53	-	-	86.6	32.1	8.34	32.51	100	291	P	V
	*	5510	86.03	-	-	78.1	32.1	8.34	32.51	100	291	A	V
		5728.145	48.7	-25.3	74	39.95	32.32	9.01	32.58	100	291	P	V
		5747.99	40.3	-13.7	54	31.48	32.34	9.07	32.59	100	291	A	V
802.11n HT40 CH 110 5550MHz		5435.68	47.44	-26.56	74	39.77	32.02	8.15	32.5	100	238	P	H
		5446.72	39.48	-14.52	54	31.79	32.04	8.15	32.5	100	238	A	H
	*	5550	97.37	-	-	89.3	32.15	8.44	32.52	100	238	P	H
	*	5550	89.07	-	-	81	32.15	8.44	32.52	100	238	A	H
		5740.745	49.05	-24.95	74	40.23	32.34	9.07	32.59	100	238	P	H
		5736.335	40.39	-13.61	54	31.57	32.34	9.07	32.59	100	238	A	H
		5395.36	48.38	-25.62	74	40.84	31.98	8.05	32.49	100	293	P	V
		5447.44	39.15	-14.85	54	31.46	32.04	8.15	32.5	100	293	A	V
	*	5550	94.87	-	-	86.8	32.15	8.44	32.52	100	293	P	V
	*	5550	86.47	-	-	78.4	32.15	8.44	32.52	100	293	A	V
		5758.7	49.56	-24.44	74	40.66	32.36	9.14	32.6	100	293	P	V
		5753.03	40.55	-13.45	54	31.71	32.36	9.07	32.59	100	293	A	V





<b>802.11n</b>  <b>HT40</b>  <b>CH 134</b>  <b>5670MHz</b>		5359.8	48.24	-25.76	74	40.7	31.92	8.11	32.49	100	239	P	H
		5466.55	39.1	-14.9	54	31.3	32.06	8.24	32.5	100	239	A	H
	*	5670	97.44	-	-	88.9	32.27	8.83	32.56	100	239	P	H
	*	5670	88.34	-	-	79.8	32.27	8.83	32.56	100	239	A	H
		5749.25	49.81	-24.19	74	40.99	32.34	9.07	32.59	100	239	P	H
		5725	40.87	-13.13	54	32.12	32.32	9.01	32.58	100	239	A	H
		5467.25	47.83	-26.17	74	40.03	32.06	8.24	32.5	100	296	P	V
		5453.25	38.98	-15.02	54	31.25	32.04	8.19	32.5	100	296	A	V
	*	5670	95.94	-	-	87.4	32.27	8.83	32.56	100	296	P	V
	*	5670	87.84	-	-	79.3	32.27	8.83	32.56	100	296	A	V
		5735.6	48.93	-25.07	74	40.11	32.34	9.07	32.59	100	296	P	V
		5725.275	40.58	-13.42	54	31.83	32.32	9.01	32.58	100	296	A	V
<b>Remark</b>	1. No other spurious found. 2. All results are PASS against Peak and Average limit line.												



**Band 3 - 5470~5725MHz**  
**WIFI 802.11n HT40 (Harmonic @ 3m)**

WIFI Ant. 1	Note	Frequency ( MHz )	Level ( dBµV/m )	Over Limit ( dB )	Limit Line ( dBµV/m )	Read Level ( dBµV )	Antenna Factor ( dB/m )	Cable Loss ( dB )	Preamp Factor ( dB )	Ant Pos ( cm )	Table Pos ( deg )	Peak Avg. ( P/A )	Pol. ( H/V )
802.11n HT40 CH 102 5510MHz		11020	46.51	-27.49	74	59.19	40.09	12.34	65.11	100	0	P	H
		16530	44.54	-29.46	74	54.52	38.88	16.21	65.07	100	0	P	H
													H
													H
		11020	46.29	-27.71	74	58.97	40.09	12.34	65.11	100	0	P	V
		16530	43.23	-30.77	74	53.21	38.88	16.21	65.07	100	0	P	V
													V
													V
802.11n HT40 CH 110 5550MHz		11100	44.98	-29.02	74	57.7	40.04	12.4	65.16	100	0	P	H
		16650	43.13	-30.87	74	52.62	39.14	16.31	64.94	100	0	P	H
													H
													H
		11100	45.9	-28.1	74	58.62	40.04	12.4	65.16	100	0	P	V
		16650	44.56	-29.44	74	54.05	39.14	16.31	64.94	100	0	P	V
													V
													V
802.11n HT40 CH 134 5670MHz		11340	43.58	-30.42	74	56.38	39.9	12.6	65.3	100	0	P	H
		17010	45.53	-28.47	74	53.54	39.98	16.59	64.58	100	0	P	H
													H
													H
		11340	45.96	-28.04	74	58.76	39.9	12.6	65.3	100	0	P	V
		17010	46.38	-27.62	74	54.39	39.98	16.59	64.58	100	0	P	V
													V
													V
Remark	1. No other spurious found. 2. All results are PASS against Peak and Average limit line.												



**Emission below 1GHz**  
**WIFI 802.11n HT40 (LF @ 3m)**

WIFI	Note	Frequency	Level	Over	Limit	Read	Antenna	Cable	Preamp	Ant	Table	Peak	Pol.	
Ant.				Limit	Line	Level	Factor	Loss	Factor	Pos	Pos	Avg.		
1		( MHz )	( dBμV/m )	( dB )	( dBμV/m )	( dBμV )	( dB/m )	( dB )	( dB )	( cm )	( deg )	( P/A )	( H/V )	
802.11n HT40 LF		30.54	22.2	-17.8	40	30.23	24.07	0.6	32.78	-	-	P	H	
		143.94	23.5	-20	43.5	37.25	17.34	1.24	32.68	-	-	P	H	
		221.7	20.68	-25.32	46	35.85	15.46	1.6	32.63	-	-	P	H	
		554.1	25.69	-20.31	46	29.82	25.55	2.47	32.74	-	-	P	H	
		750.8	30.31	-15.69	46	31.25	28.27	2.9	32.71	100	0	P	H	
		963.6	35.14	-18.86	54	31.29	31.09	3.32	31.37	-	-	P	H	
														H
														H
														H
														H
														H
														H
			35.94	28.43	-11.57	40	38.95	21.56	0.6	32.77	100	0	P	V
			58.35	21.65	-18.35	40	41.28	12.1	0.88	32.75	-	-	P	V
			67.53	22.55	-17.45	40	42.02	12.22	0.88	32.74	-	-	P	V
			610.8	27.14	-18.86	46	31.01	25.78	2.59	32.82	-	-	P	V
			840.4	31.57	-14.43	46	31.49	28.76	3.09	32.43	-	-	P	V
			921.6	32.6	-13.4	46	31.07	29.36	3.26	31.84	-	-	P	V
														V
														V
													V	
													V	
													V	
													V	
<b>Remark</b>	1. No other spurious found. 2. All results are PASS against limit line.													



**Note symbol**

*	<b>Fundamental Frequency</b> which can be ignored. However, the level of any unwanted emissions shall not exceed the level of the fundamental frequency.
!	Test result is <b>over limit</b> line.
P/A	<b>Peak</b> or <b>Average</b>
H/V	<b>Horizontal</b> or <b>Vertical</b>



A calculation example for radiated spurious emission is shown as below:

WIFI	Note	Frequency	Level	Over	Limit	Read	Antenna	Cable	Preamp	Ant	Table	Peak	Pol.
Ant.				Limit	Line	Level	Factor	Loss	Factor	Pos	Pos	Avg.	
1		( MHz )	( dBμV/m )	( dB )	( dBμV/m )	( dBμV )	( dB/m )	( dB )	( dB )	( cm )	( deg )	( P/A )	( H/V )
802.11b		2390	55.45	-18.55	74	54.51	32.22	4.58	35.86	103	308	P	H
CH 01													
2412MHz		2390	43.54	-10.46	54	42.6	32.22	4.58	35.86	103	308	A	H

- Level(dBμV/m) =  
Antenna Factor(dB/m) + Cable Loss(dB) + Read Level(dBμV) - Preamp Factor(dB)
- Over Limit(dB) = Level(dBμV/m) – Limit Line(dBμV/m)

**For Peak Limit @ 2390MHz:**

- Level(dBμV/m)  
= Antenna Factor(dB/m) + Cable Loss(dB) + Read Level(dBμV) - Preamp Factor(dB)  
= 32.22(dB/m) + 4.58(dB) + 54.51(dBμV) – 35.86 (dB)  
= 55.45 (dBμV/m)
- Over Limit(dB)  
= Level(dBμV/m) – Limit Line(dBμV/m)  
= 55.45(dBμV/m) – 74(dBμV/m)  
= -18.55(dB)

**For Average Limit @ 2390MHz:**

- Level(dBμV/m)  
= Antenna Factor(dB/m) + Cable Loss(dB) + Read Level(dBμV) - Preamp Factor(dB)  
= 32.22(dB/m) + 4.58(dB) + 42.6(dBμV) – 35.86 (dB)  
= 43.54 (dBμV/m)
- Over Limit(dB)  
= Level(dBμV/m) – Limit Line(dBμV/m)  
= 43.54(dBμV/m) – 54(dBμV/m)  
= -10.46(dB)

Both peak and average measured complies with the limit line, so test result is “PASS”.



## Appendix D. Radiated Spurious Emission Plots

Test Engineer :	Lance Chiang and Yun Huang	Temperature :	22~24°C
		Relative Humidity :	52~58%

### Note symbol

-L	Low channel location
-R	High channel location



**Band 1 - 5150~5250MHz**  
**WIFI 802.11a (Band Edge @ 3m)**

WIFI	Band 1 5150~5250MHz Band Edge @ 3m	
ANT	802.11a CH36 5180MHz	
1	Horizontal	Fundamental
<b>Peak</b>	<p>Site : 03CH10-HY Condition : PEAK_BE_74 3m HORN 91200-HF HORIZONTAL Detector : Peak Project : 7D2018-03 Mode : 1 Setting : 11/1</p>	<p>Site : 03CH10-HY Condition : PEAK_74 3m HORN 91200-HF HORIZONTAL Detector : Peak Project : 7D2018-03 Mode : 1 Setting : 11/1</p>
<b>Avg.</b>	<p>Site : 03CH10-HY Condition : AV6_BE_54 3m HORN 91200-HF HORIZONTAL Detector : Peak Project : 7D2018-03 Mode : 1 Setting : 11/1</p>	<b>Left blank</b>

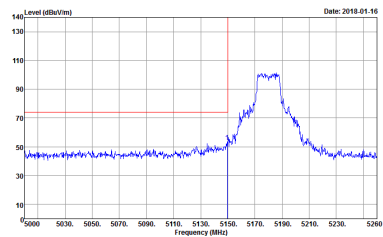
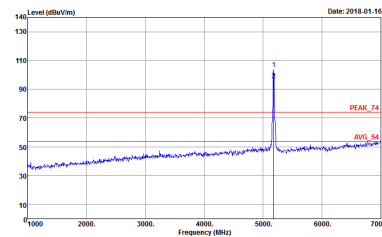
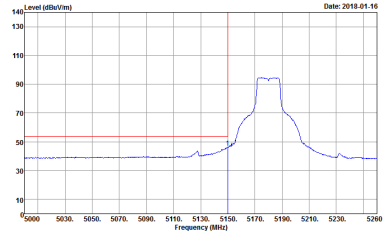

WIFI	Band 1 5150~5250MHz Band Edge @ 3m	
ANT	802.11a CH36 5180MHz	
1	Vertical	Fundamental
<p><b>Peak</b></p>	 <p>Site : 03CH10-HY            Condition : PEAK_BE_74 3m HORN 91200-HF VERTICAL            Detector : Peak            Project : 7D2018-03            Mode : 1            Setting : 11/1</p>	 <p>Site : 03CH10-HY            Condition : PEAK_74 3m HORN 91200-HF VERTICAL            Detector : Peak            Project : 7D2018-03            Mode : 1            Setting : 11/1</p>
<p><b>Avg.</b></p>	 <p>Site : 03CH10-HY            Condition : AVG_BE_54 3m HORN 91200-HF VERTICAL            Detector : Peak            Project : 7D2018-03            Mode : 1            Setting : 11/1</p>	<p><b>Left blank</b></p>



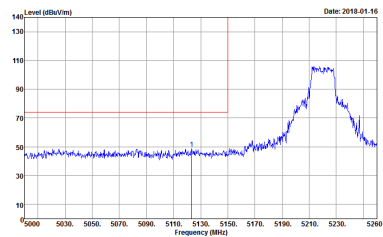
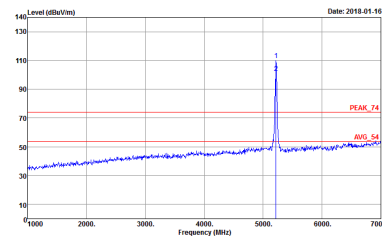
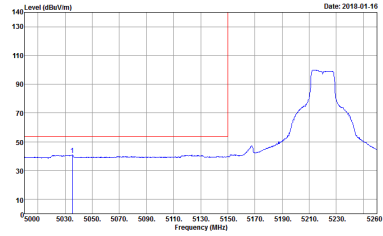

WIFI	Band 1 5150~5250MHz Band Edge @ 3m	
ANT	802.11a CH44 5220MHz - L	
1	Horizontal	Fundamental
<p><b>Peak</b></p>	 <p>Site : 03CH10-HY            Condition : PEAK_BE_74 3m HORN 9120D-HF HORIZONTAL            RBW:1000.000KHz VBW:3000.000KHz SWT:Auto            Detector : Peak            Project : 7D2018-03            Mode : 2            Setting : 13/1</p>	 <p>Site : 03CH10-HY            Condition : PEAK_74 3m HORN 9120D-HF HORIZONTAL            RBW:1000.000KHz VBW:3000.000KHz SWT:Auto            Detector : Peak            Project : 7D2018-03            Mode : 2            Setting : 13/1</p>
<p><b>Avg.</b></p>	 <p>Site : 03CH10-HY            Condition : AVG_BE_54 3m HORN 9120D-HF HORIZONTAL            RBW:1000.000KHz VBW:1000KHz SWT:Auto            Detector : Peak            Project : 7D2018-03            Mode : 2            Setting : 13/1</p>	<p><b>Left blank</b></p>

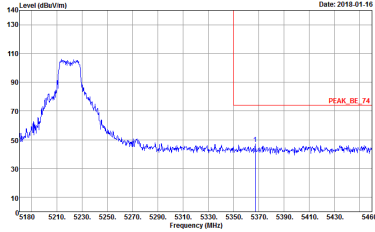
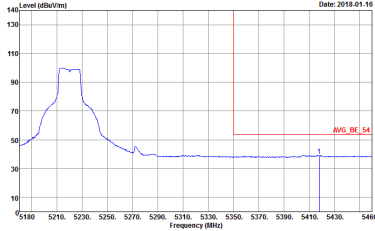

WIFI	Band 1 5150~5250MHz Band Edge @ 3m	
ANT	802.11a CH44 5220MHz - R	
1	Horizontal	Fundamental
<p><b>Peak</b></p>	 <p>Site : 03CH10-HY            Condition : PEAK_BE_74 3m HORN 91200-HF HORIZONTAL            : RBW:1000.000KHz VBW:3000.000KHz SWT:Auto            Detector : Peak            Project : 7D2018-03            Mode : 2            Setting : 13/1</p>	<p>Left blank</p>
<p><b>Avg.</b></p>	 <p>Site : 03CH10-HY            Condition : AVG_BE_54 3m HORN 91200-HF HORIZONTAL            : RBW:1000.000KHz VBW:1000KHz SWT:Auto            Detector : Peak            Project : 7D2018-03            Mode : 2            Setting : 13/1</p>	<p>Left blank</p>

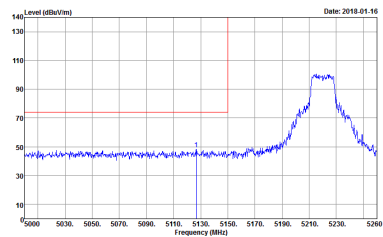
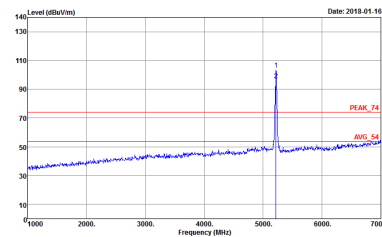
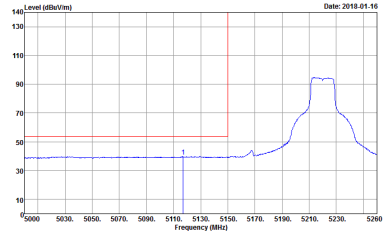

WIFI	Band 1 5150~5250MHz Band Edge @ 3m	
ANT	802.11a CH44 5220MHz - L	
1	Vertical	Fundamental
<p><b>Peak</b></p>	 <p>Site : 03CH10-HY            Condition : PEAK_BE_74 3m HORN 91200-HF VERTICAL            RBW:1000.000KHz VBW:3000.000KHz SWT:Auto            Detector : Peak            Project : 7D2018-03            Mode : 2            Setting : 13/1</p>	 <p>Site : 03CH10-HY            Condition : PEAK_74 3m HORN 91200-HF VERTICAL            RBW:1000.000KHz VBW:3000.000KHz SWT:Auto            Detector : Peak            Project : 7D2018-03            Mode : 2            Setting : 13/1</p>
<p><b>Avg.</b></p>	 <p>Site : 03CH10-HY            Condition : AVG_BE_54 3m HORN 91200-HF VERTICAL            RBW:1000.000KHz VBW:1000KHz SWT:Auto            Detector : Peak            Project : 7D2018-03            Mode : 2            Setting : 13/1</p>	<p><b>Left blank</b></p>

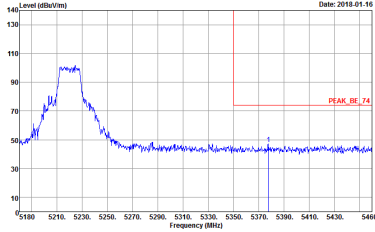
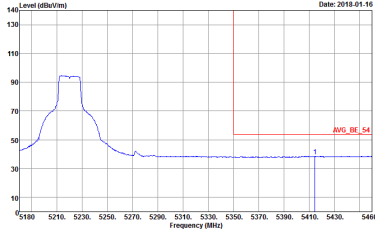

WIFI	Band 1 5150~5250MHz Band Edge @ 3m	
ANT	802.11a CH44 5220MHz - R	
1	Vertical	Fundamental
<p><b>Peak</b></p>	 <p>Site : 03CH10-HY            Condition : PEAK_BE_74 3m HORN 91200-HF VERTICAL            : RBW:1000.000KHz VBW:3000.000KHz SWT:Auto            Detector : Peak            Project : 7D2018-03            Mode : 2            Setting : 13/1</p>	<p>Left blank</p>
<p><b>Avg.</b></p>	 <p>Site : 03CH10-HY            Condition : AVG_BE_54 3m HORN 91200-HF VERTICAL            : RBW:1000.000KHz VBW:1000KHz SWT:Auto            Detector : Peak            Project : 7D2018-03            Mode : 2            Setting : 13/1</p>	<p>Left blank</p>

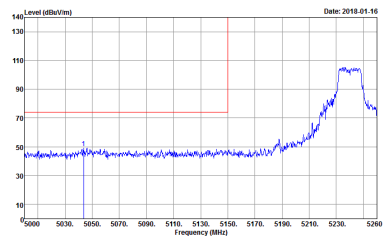
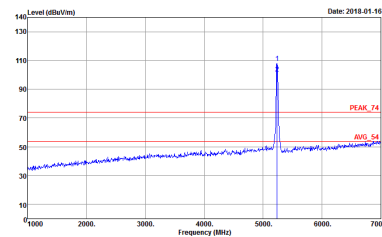
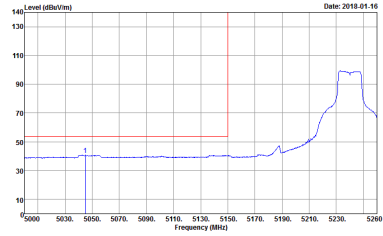

WIFI	Band 1 5150~5250MHz Band Edge @ 3m	
ANT	802.11a CH48 5240MHz - L	
1	Horizontal	Fundamental
<p><b>Peak</b></p>	 <p>Site : 03CH10-HY            Condition : PEAK_BE_74 3m HORN 91200-HF HORIZONTAL            RBW:1000.000KHz VBW:3000.000KHz SWT:Auto            Detector : Peak            Project : 7D2018-03            Mode : 3            Setting : 13/2</p>	 <p>Site : 03CH10-HY            Condition : PEAK_74 3m HORN 91200-HF HORIZONTAL            RBW:1000.000KHz VBW:3000.000KHz SWT:Auto            Detector : Peak            Project : 7D2018-03            Mode : 3            Setting : 13/2</p>
<p><b>Avg.</b></p>	 <p>Site : 03CH10-HY            Condition : AVG_BE_54 3m HORN 91200-HF HORIZONTAL            RBW:1000.000KHz VBW:1000KHz SWT:Auto            Detector : Peak            Project : 7D2018-03            Mode : 3            Setting : 13/2</p>	<p>Left blank</p>

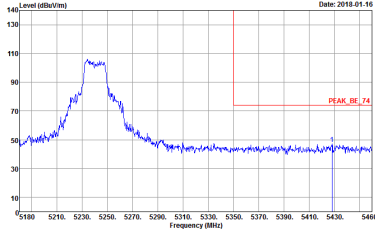
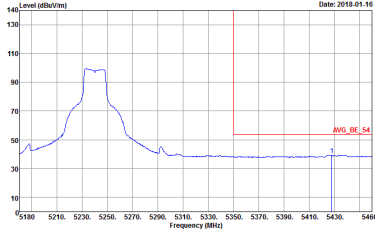

WIFI	Band 1 5150~5250MHz Band Edge @ 3m	
ANT	802.11a CH48 5240MHz - R	
1	Horizontal	Fundamental
<p><b>Peak</b></p>	 <p>Site : 03CH10-HY            Condition : PEAK_BE_74 3m HORN 91200-HF HORIZONTAL            RBW:1000.000KHz VBW:3000.000KHz SWT:Auto            Detector : Peak            Project : 7D2018-03            Mode : 3            Setting : 13/2</p>	<p>Left blank</p>
<p><b>Avg.</b></p>	 <p>Site : 03CH10-HY            Condition : AVG_BE_54 3m HORN 91200-HF HORIZONTAL            RBW:1000.000KHz VBW:1000KHz SWT:Auto            Detector : Peak            Project : 7D2018-03            Mode : 3            Setting : 13/2</p>	<p>Left blank</p>

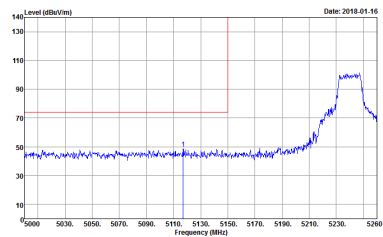
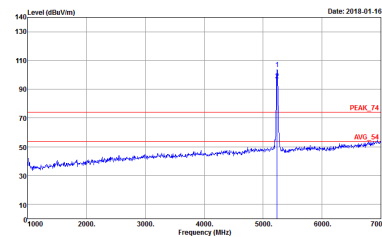
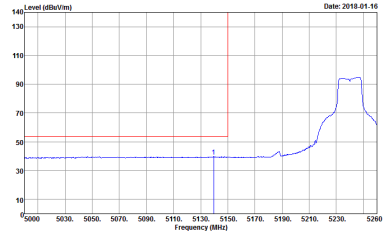

WIFI	Band 1 5150~5250MHz Band Edge @ 3m	
ANT	802.11a CH48 5240MHz - L	
1	Vertical	Fundamental
<p><b>Peak</b></p>	 <p>Site : 03CH10-HY          Condition : PEAK_BE_74 3m HORN 91200-HF VERTICAL          RBW:1000.000KHz VBW:3000.000KHz SWT:Auto          Detector : Peak          Project : 7D2018-03          Mode : 3          Setting : 13/2</p>	 <p>Site : 03CH10-HY          Condition : PEAK_74 3m HORN 91200-HF VERTICAL          RBW:1000.000KHz VBW:3000.000KHz SWT:Auto          Detector : Peak          Project : 7D2018-03          Mode : 3          Setting : 13/2</p>
<p><b>Avg.</b></p>	 <p>Site : 03CH10-HY          Condition : AVG_BE_54 3m HORN 91200-HF VERTICAL          RBW:1000.000KHz VBW:1000KHz SWT:Auto          Detector : Peak          Project : 7D2018-03          Mode : 3          Setting : 13/2</p>	<p><b>Left blank</b></p>

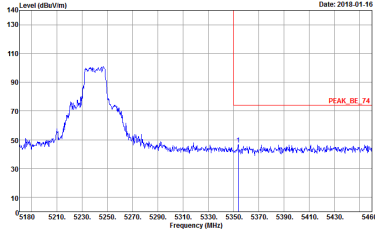
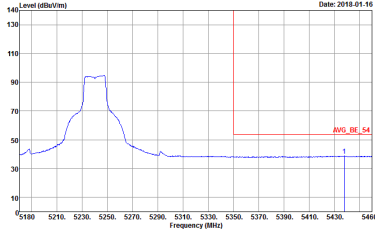

WIFI	Band 1 5150~5250MHz Band Edge @ 3m	
ANT	802.11a CH48 5240MHz - R	
1	Vertical	Fundamental
<p><b>Peak</b></p>	 <p>Site : 03CH10-HY            Condition : PEAK_BE_74 3m HORN 91200-HF VERTICAL            : RBW:1000.000KHz VBW:3000.000KHz SWT:Auto            Detector : Peak            Project : 7D2018-03            Mode : 3            Setting : 13/2</p>	<p>Left blank</p>
<p><b>Avg.</b></p>	 <p>Site : 03CH10-HY            Condition : AVG_BE_54 3m HORN 91200-HF VERTICAL            : RBW:1000.000KHz VBW:1000KHz SWT:Auto            Detector : Peak            Project : 7D2018-03            Mode : 3            Setting : 13/2</p>	<p>Left blank</p>



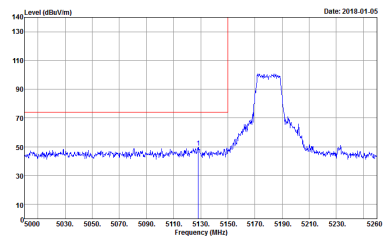
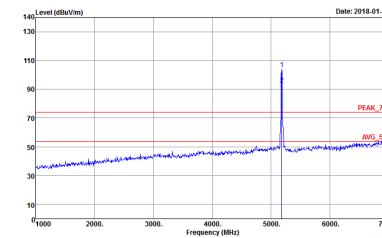
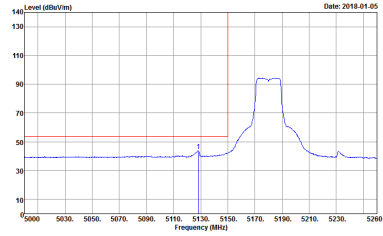

**Band 1 5150~5250MHz**  
**WIFI 802.11n HT20 (Band Edge @ 3m)**

WIFI	Band 1 5150~5250MHz Band Edge @ 3m	
ANT	802.11n HT20 CH36 5180MHz	
1	Horizontal	Fundamental
<b>Peak</b>	 <p>Site : 03CH10-HY            Condition : PEAK_BE_74 3m HORN 9120D-HF HORIZONTAL            RBW:1000.000KHz VBW:3000.000KHz SWT:Auto            Detector : Peak            Project : 7D2018-03            Mode : 4</p>	 <p>Site : 03CH10-HY            Condition : PEAK_74 3m HORN 9120D-HF HORIZONTAL            RBW:1000.000KHz VBW:3000.000KHz SWT:Auto            Detector : Peak            Project : 7D2018-03            Mode : 4</p>
<b>Avg.</b>	 <p>Site : 03CH10-HY            Condition : AVG_BE_54 3m HORN 9120D-HF HORIZONTAL            RBW:1000.000KHz VBW:1.000KHz SWT:Auto            Detector : Peak            Project : 7D2018-03            Mode : 4</p>	<b>Left blank</b>



WIFI	Band 1 5150~5250MHz Band Edge @ 3m	
ANT	802.11n HT20 CH36 5180MHz	
1	Vertical	Fundamental
<p><b>Peak</b></p>	<p>Site : 03CH10-HY            Condition : PEAK_BE_74 3m HORN 91200-HF VERTICAL            Detector : Peak            Project : 7D2018-03            Mode : 4</p>	<p>Site : 03CH10-HY            Condition : PEAK_74 3m HORN 91200-HF VERTICAL            Detector : Peak            Project : 7D2018-03            Mode : 4</p>
<p><b>Avg.</b></p>	<p>Site : 03CH10-HY            Condition : AVG_BE_54 3m HORN 91200-HF VERTICAL            Detector : Peak            Project : 7D2018-03            Mode : 4</p>	<p><b>Left blank</b></p>

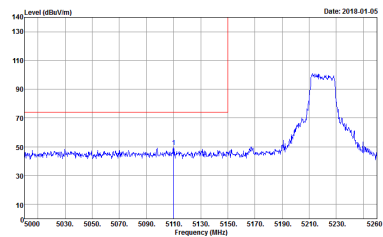
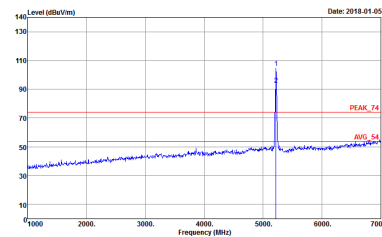
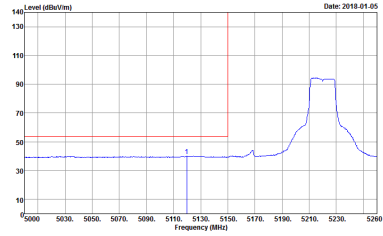

WIFI	Band 1 5150~5250MHz Band Edge @ 3m	
ANT	802.11n HT20 CH44 5220MHz - L	
1	Horizontal	Fundamental
<p><b>Peak</b></p>	 <p>Site : 03CH10-HY            Condition : PEAK_BE_74 3m HORN 91200-HF HORIZONTAL            : RBW:1000.000KHz VBW:3000.000KHz SWT:Auto            Detector : Peak            Project : 7D2018-03            Mode : 5</p>	 <p>Site : 03CH10-HY            Condition : PEAK_74 3m HORN 91200-HF HORIZONTAL            : RBW:1000.000KHz VBW:3000.000KHz SWT:Auto            Detector : Peak            Project : 7D2018-03            Mode : 5</p>
<p><b>Avg.</b></p>	 <p>Site : 03CH10-HY            Condition : AVG_BE_54 3m HORN 91200-HF HORIZONTAL            : RBW:1000.000KHz VBW:1000KHz SWT:Auto            Detector : Peak            Project : 7D2018-03            Mode : 5</p>	<p><b>Left blank</b></p>

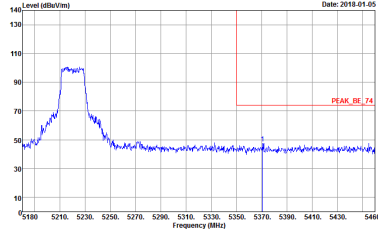
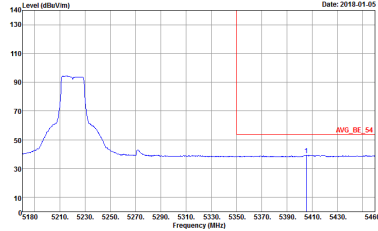

WIFI	Band 1 5150~5250MHz Band Edge @ 3m	
ANT	802.11n HT20 CH44 5220MHz - R	
1	Horizontal	Fundamental
Peak	 <p>Site : 03CH10-HY            Condition : PEAK_BE_74 3m HORN 91200-HF HORIZONTAL            RBW:1000.000KHz VBW:3000.000KHz SWT:Auto            Detector : Peak            Project : 7D2018-03            Mode : 5</p>	Left blank
Avg.	 <p>Site : 03CH10-HY            Condition : AVG_BE_54 3m HORN 91200-HF HORIZONTAL            RBW:1000.000KHz VBW:1000KHz SWT:Auto            Detector : Peak            Project : 7D2018-03            Mode : 5</p>	Left blank



WIFI	Band 1 5150~5250MHz Band Edge @ 3m	
ANT	802.11n HT20 CH44 5220MHz - L	
1	Vertical	Fundamental
<b>Peak</b>	<p>Site : 03CH10-HY            Condition : PEAK_BE_74 3m HORN 9120D-HF VERTICAL            : RBW:1000.000KHz VBW:3000.000KHz SWT:Auto            Detector : Peak            Project : 7D2018-03            Mode : 5</p>	<p>Site : 03CH10-HY            Condition : PEAK_74 3m HORN 9120D-HF VERTICAL            : RBW:1000.000KHz VBW:3000.000KHz SWT:Auto            Detector : Peak            Project : 7D2018-03            Mode : 5</p>
<b>Avg.</b>	<p>Site : 03CH10-HY            Condition : AVG_BE_54 3m HORN 9120D-HF VERTICAL            : RBW:1000.000KHz VBW:1000KHz SWT:Auto            Detector : Peak            Project : 7D2018-03            Mode : 5</p>	<b>Left blank</b>

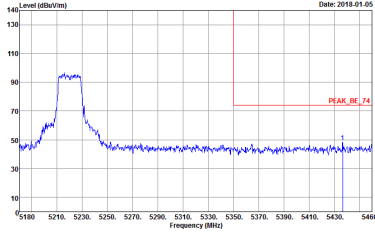
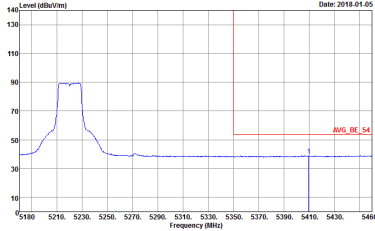

WIFI	Band 1 5150~5250MHz Band Edge @ 3m	
ANT	802.11n HT20 CH44 5220MHz - R	
1	Vertical	Fundamental
<p><b>Peak</b></p>	 <p>Site : 03CH10-HY            Condition : PEAK_BE_74 3m HORN 91200-HF VERTICAL            : RBW:1000.000KHz VBW:3000.000KHz SWT:Auto            Detector : Peak            Project : 7D2018-03            Mode : 5</p>	<p>Left blank</p>
<p><b>Avg.</b></p>	 <p>Site : 03CH10-HY            Condition : AVG_BE_54 3m HORN 91200-HF VERTICAL            : RBW:1000.000KHz VBW:1000KHz SWT:Auto            Detector : Peak            Project : 7D2018-03            Mode : 5</p>	<p>Left blank</p>



WIFI	Band 1 5150~5250MHz Band Edge @ 3m	
ANT	802.11n HT20 CH48 5240MHz - L	
1	Horizontal	Fundamental
<p><b>Peak</b></p>	<p>Site : 03CH10-HY            Condition : PEAK_BE_74 3m HORN 9120D-HF HORIZONTAL            Detector : Peak            Project : 7D2018-03            Mode : 6</p>	<p>Site : 03CH10-HY            Condition : PEAK_74 3m HORN 9120D-HF HORIZONTAL            Detector : Peak            Project : 7D2018-03            Mode : 6</p>
<p><b>Avg.</b></p>	<p>Site : 03CH10-HY            Condition : AVG_BE_54 3m HORN 9120D-HF HORIZONTAL            Detector : Peak            Project : 7D2018-03            Mode : 6</p>	<p><b>Left blank</b></p>

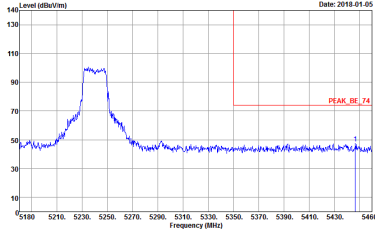
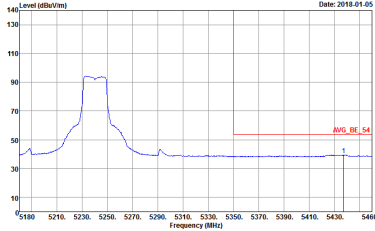

WIFI	Band 1 5150~5250MHz Band Edge @ 3m	
ANT	802.11n HT20 CH48 5240MHz - R	
1	Horizontal	Fundamental
Peak	 <p>           Site : 03CH10-HY            Condition : PEAK_BE_74 3m HORN 91200-HF HORIZONTAL            Detector : Peak            Project : 7D2018-03            Mode : 6         </p>	Left blank
Avg.	 <p>           Site : 03CH10-HY            Condition : AVG_BE_54 3m HORN 91200-HF HORIZONTAL            Detector : Peak            Project : 7D2018-03            Mode : 6         </p>	Left blank





WIFI	Band 1 5150~5250MHz Band Edge @ 3m	
ANT	802.11n HT20 CH48 5240MHz - L	
1	Vertical	Fundamental
<b>Peak</b>	<p>Site : 03CH10-HY            Condition : PEAK_BE_74 3m HORN 91200-HF VERTICAL            : RBW:1000.000KHz VBW:3000.000KHz SWT:Auto            Detector : Peak            Project : 7D2018-03            Mode : 6</p>	<p>Site : 03CH10-HY            Condition : PEAK_74 3m HORN 91200-HF VERTICAL            : RBW:1000.000KHz VBW:3000.000KHz SWT:Auto            Detector : Peak            Project : 7D2018-03            Mode : 6</p>
<b>Avg.</b>	<p>Site : 03CH10-HY            Condition : AVG_BE_54 3m HORN 91200-HF VERTICAL            : RBW:1000.000KHz VBW:1000KHz SWT:Auto            Detector : Peak            Project : 7D2018-03            Mode : 6</p>	<b>Left blank</b>

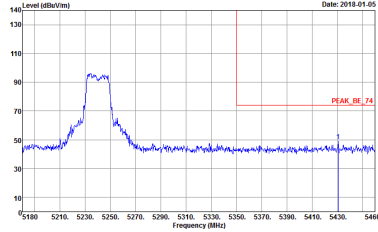
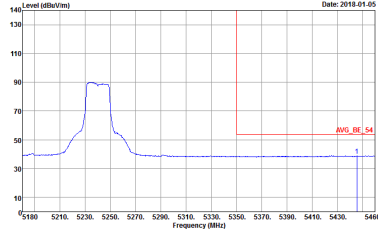

WIFI	Band 1 5150~5250MHz Band Edge @ 3m	
ANT	802.11n HT20 CH48 5240MHz - R	
1	Vertical	Fundamental
Peak	 <p>           Site : 03CH10-HY            Condition : PEAK_BE_74 3m HORN 91200-HF VERTICAL            Detector : Peak            Project : 7D2018-03            Mode : 6         </p>	Left blank
Avg.	 <p>           Site : 03CH10-HY            Condition : AVG_BE_54 3m HORN 91200-HF VERTICAL            Detector : Peak            Project : 7D2018-03            Mode : 6         </p>	Left blank



**Band 1 5150~5250MHz  
WIFI 802.11n HT40 (Band Edge @ 3m)**

WIFI	Band 1 5150~5250MHz Band Edge @ 3m	
ANT	802.11n HT40 CH38 5190MHz - L	
1	Horizontal	Fundamental
<b>Peak</b>	<p>Site : 03CH10-HY Condition : PEAK_BE_74 3m HORN 9120D-HF HORIZONTAL RBW:1000.000KHz VBW:3000.000KHz SWT:Auto Detector : Peak Project : 7D2018-03 Mode : 7</p>	<p>Site : 03CH10-HY Condition : PEAK_74 3m HORN 9120D-HF HORIZONTAL RBW:1000.000KHz VBW:3000.000KHz SWT:Auto Detector : Peak Project : 7D2018-03 Mode : 7</p>
<b>Avg.</b>	<p>Site : 03CH10-HY Condition : AVG_BE_54 3m HORN 9120D-HF HORIZONTAL RBW:1000.000KHz VBW:1.000KHz SWT:Auto Detector : Peak Project : 7D2018-03 Mode : 7</p>	<b>Left blank</b>

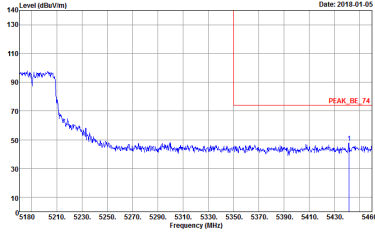
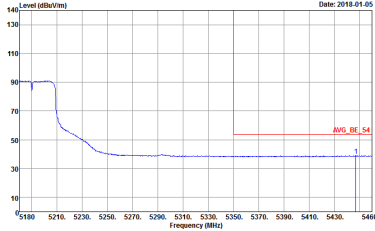

WIFI	Band 1 5150~5250MHz Band Edge @ 3m	
ANT	802.11n HT40 CH38 5190MHz - R	
1	Horizontal	Fundamental
Peak	 <p>           Site : 03CH10-HY            Condition : PEAK_BE_74 3m HORN 91200-HF HORIZONTAL            Detector : Peak            Project : 7D2018-03            Mode : 7         </p>	Left blank
Avg.	 <p>           Site : 03CH10-HY            Condition : AVG_BE_54 3m HORN 91200-HF HORIZONTAL            Detector : Peak            Project : 7D2018-03            Mode : 7         </p>	Left blank



WIFI	Band 1 5150~5250MHz Band Edge @ 3m	
ANT	802.11n HT40 CH38 5190MHz - L	
1	Vertical	Fundamental
<b>Peak</b>	<p>Site : 03CH10-HY            Condition : PEAK_BE_74 3m HORN 9120D-HF VERTICAL            : RBW:1000.000KHz VBW:3000.000KHz SWT:Auto            Detector : Peak            Project : 7D2018-03            Mode : 7</p>	<p>Site : 03CH10-HY            Condition : PEAK_74 3m HORN 9120D-HF VERTICAL            : RBW:1000.000KHz VBW:3000.000KHz SWT:Auto            Detector : Peak            Project : 7D2018-03            Mode : 7</p>
<b>Avg.</b>	<p>Site : 03CH10-HY            Condition : AVG_BE_54 3m HORN 9120D-HF VERTICAL            : RBW:1000.000KHz VBW:1000KHz SWT:Auto            Detector : Peak            Project : 7D2018-03            Mode : 7</p>	<b>Left blank</b>

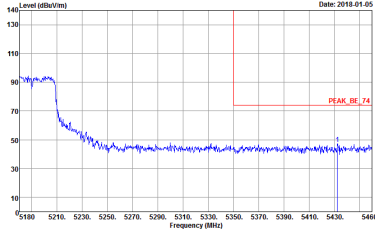
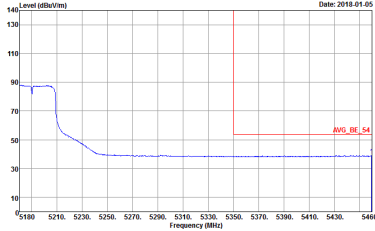

WIFI	Band 1 5150~5250MHz Band Edge @ 3m	
ANT	802.11n HT40 CH38 5190MHz - R	
1	Vertical	Fundamental
<p><b>Peak</b></p>	 <p>Site : 03CH10-HY            Condition : PEAK_BE_74 3m HORN 91200-HF VERTICAL            Detector : Peak            Project : 7D2018-03            Mode : 7</p>	<p>Left blank</p>
<p><b>Avg.</b></p>	 <p>Site : 03CH10-HY            Condition : AVG_BE_54 3m HORN 91200-HF VERTICAL            Detector : Peak            Project : 7D2018-03            Mode : 7</p>	<p>Left blank</p>

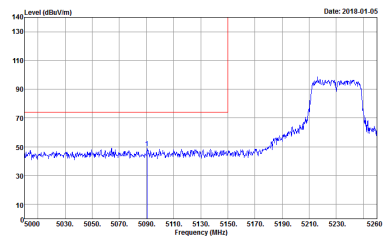
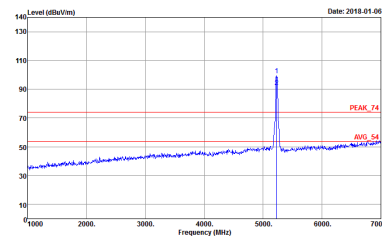
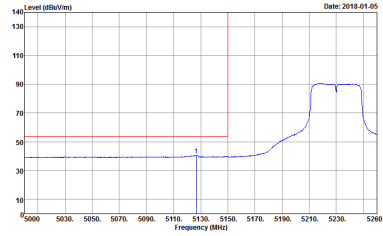

WIFI	Band 1 5150~5250MHz Band Edge @ 3m	
ANT	802.11n HT40 CH46 5230MHz - L	
1	Horizontal	Fundamental
<p><b>Peak</b></p>	 <p>Site : 03CH10-HY            Condition : PEAK_BE_74 3m HORN 9120D-HF HORIZONTAL            Detector : Peak            Project : 7D2018-03            Mode : B</p>	 <p>Site : 03CH10-HY            Condition : PEAK_74 3m HORN 9120D-HF HORIZONTAL            Detector : Peak            Project : 7D2018-03            Mode : B</p>
<p><b>Avg.</b></p>	 <p>Site : 03CH10-HY            Condition : AVG_BE_54 3m HORN 9120D-HF HORIZONTAL            Detector : Peak            Project : 7D2018-03            Mode : B</p>	<p>Left blank</p>

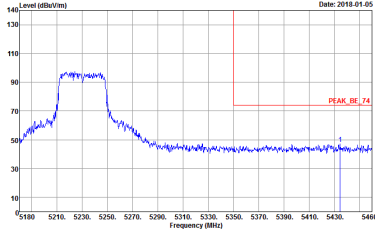
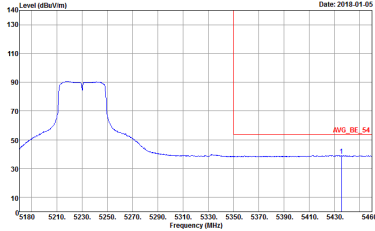

WIFI	Band 1 5150~5250MHz Band Edge @ 3m	
ANT	802.11n HT40 CH46 5230MHz - R	
1	Horizontal	Fundamental
Peak	 <p>           Site : 03CH10-HY            Condition : PEAK_BE_74 3m HORN 91200-HF HORIZONTAL            Detector : Peak            Project : 7D2018-03            Mode : B         </p>	Left blank
Avg.	 <p>           Site : 03CH10-HY            Condition : AVG_BE_54 3m HORN 91200-HF HORIZONTAL            Detector : Peak            Project : 7D2018-03            Mode : B         </p>	Left blank





WIFI	Band 1 5150~5250MHz Band Edge @ 3m	
ANT	802.11n HT40 CH46 5230MHz - L	
1	Vertical	Fundamental
<b>Peak</b>	<p>Site : 03CH10-HY            Condition : PEAK_BE_74 3m HORN 91200-HF VERTICAL            : RBW:1000.000KHz VBW:3000.000KHz SWT:Auto            Detector : Peak            Project : 7D2018-03            Mode : B</p>	<p>Site : 03CH10-HY            Condition : PEAK_74 3m HORN 91200-HF VERTICAL            : RBW:1000.000KHz VBW:3000.000KHz SWT:Auto            Detector : Peak            Project : 7D2018-03            Mode : B</p>
<b>Avg.</b>	<p>Site : 03CH10-HY            Condition : AVG_BE_54 3m HORN 91200-HF VERTICAL            : RBW:1000.000KHz VBW:1000KHz SWT:Auto            Detector : Peak            Project : 7D2018-03            Mode : B</p>	<b>Left blank</b>

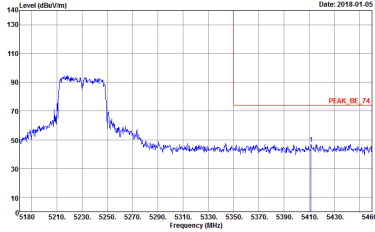
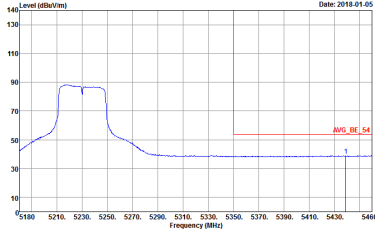

WIFI	Band 1 5150~5250MHz Band Edge @ 3m	
ANT	802.11n HT40 CH46 5230MHz - R	
1	Vertical	Fundamental
<p><b>Peak</b></p>	 <p>Site : 03CH10-HY            Condition : PEAK_BE_74 3m HORN 91200-HF VERTICAL            Detector : Peak            Project : 7D2018-03            Mode : B</p>	<p>Left blank</p>
<p><b>Avg.</b></p>	 <p>Site : 03CH10-HY            Condition : AVG_BE_54 3m HORN 91200-HF VERTICAL            Detector : Peak            Project : 7D2018-03            Mode : B</p>	<p>Left blank</p>



**Band 1 - 5150~5250MHz**

**WIFI 802.11a (Harmonic @ 3m)**

WIFI	Band 1 5150~5250MHz Harmonic @ 3m	
ANT	802.11a CH36 5180MHz	
1	Horizontal	Vertical
<b>Peak</b>  <b>Avg.</b>	<p>Site : 03CH10-HY            Condition : PEAK_74 3m HORN 91200-HF HORIZONTAL            Detector : Peak            Project : 7D2018-03            Mode : 1</p>	<p>Site : 03CH10-HY            Condition : PEAK_74 3m HORN 91200-HF VERTICAL            Detector : Peak            Project : 7D2018-03            Mode : 1</p>



WIFI	Band 1 5150~5250MHz Harmonic @ 3m	
ANT	802.11a CH44 5220MHz	
1	Horizontal	Vertical
Peak Avg.	<p>Site : 03CH10-11Y Condition : PEAK_74 3m HORN 91200-HF HORIZONTAL Detector : Peak Project : 7D2018-03 Mode : Z</p>	<p>Site : 03CH10-11Y Condition : PEAK_74 3m HORN 91200-HF VERTICAL Detector : Peak Project : 7D2018-03 Mode : Z</p>

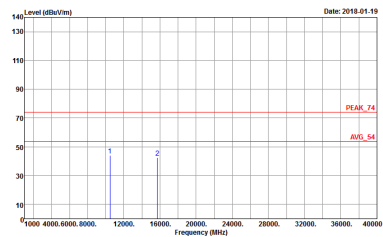
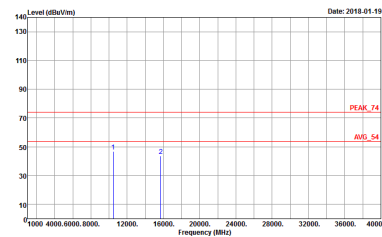

WIFI	Band 1 5150~5250MHz Harmonic @ 3m	
ANT	802.11a CH48 5240MHz	
1	Horizontal	Vertical
<p>Peak</p> <p>Avg.</p>	 <p>Site : 03CH10-11Y          Condition : PEAK_74 3m HORN 91200-HF HORIZONTAL          Detector : Peak          Project : 7D2018-03          Mode : 3</p>	 <p>Site : 03CH10-11Y          Condition : PEAK_74 3m HORN 91200-HF VERTICAL          Detector : Peak          Project : 7D2018-03          Mode : 3</p>



**Band 1 5150~5250MHz  
WIFI 802.11n HT20 (Harmonic @ 3m)**

<b>WIFI</b>	<b>Band 1 5150~5250MHz Harmonic @ 3m</b>	
<b>ANT</b>	<b>802.11n HT20 CH36 5180MHz</b>	
<b>1</b>	<b>Horizontal</b>	<b>Vertical</b>
<b>Peak Avg.</b>	<p>Site : 03CH10-HY Condition : PEAK_74 3m HORN 91200-HF HORIZONTAL Detector : Peak Project : 7D2018-03 Mode : 4</p>	<p>Site : 03CH10-HY Condition : PEAK_74 3m HORN 91200-HF VERTICAL Detector : Peak Project : 7D2018-03 Mode : 4</p>

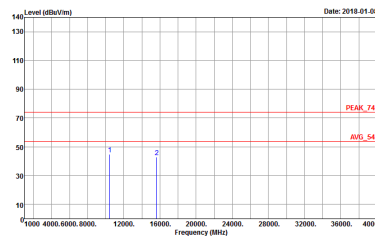
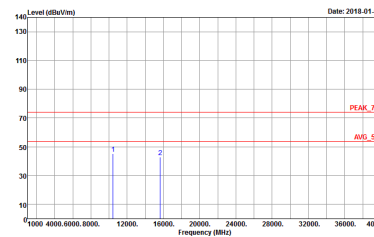

WIFI	Band 1 5150~5250MHz Harmonic @ 3m	
ANT	802.11n HT20 CH44 5220MHz	
1	Horizontal	Vertical
<p>Peak</p> <p>Avg.</p>	 <p>Site : 03CH10-11Y          Condition : PEAK_74 3m HORN 91200-HF HORIZONTAL          Detector : Peak          Project : 7D2018-03          Mode : -5</p>	 <p>Site : 03CH10-11Y          Condition : PEAK_74 3m HORN 91200-HF VERTICAL          Detector : Peak          Project : 7D2018-03          Mode : -5</p>

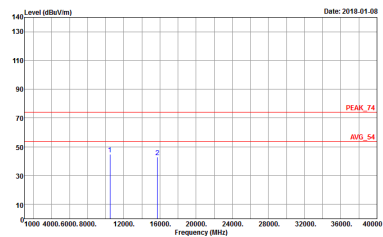
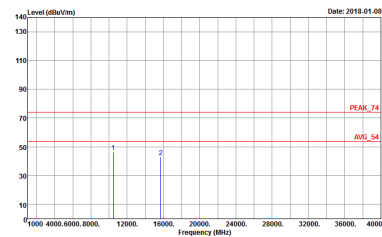

WIFI	Band 1 5150~5250MHz Harmonic @ 3m	
ANT	802.11n HT20 CH48 5240MHz	
1	Horizontal	Vertical
<p>Peak</p> <p>Avg.</p>	 <p>Site : 03CH10-11Y  Condition : PEAK_74 3m HORN 91200-HF HORIZONTAL  Detector : Peak  Project : 7D2018-03  Mode : -6</p>	 <p>Site : 03CH10-11Y  Condition : PEAK_74 3m HORN 91200-HF VERTICAL  Detector : Peak  Project : 7D2018-03  Mode : -6</p>





**Band 1 5150~5250MHz  
WIFI 802.11n HT40 (Harmonic @ 3m)**

<b>WIFI</b>	<b>Band 1 5150~5250MHz Harmonic @ 3m</b>	
<b>ANT</b>	<b>802.11n HT40 CH38 5190MHz</b>	
<b>1</b>	<b>Horizontal</b>	<b>Vertical</b>
<b>Peak</b> <b>Avg.</b>	<p>Site : 03CH10-HY Condition : PEAK_74 3m HORN 91200-HF HORIZONTAL Detector : Peak Project : 7D2018-03 Mode : 7</p>	<p>Site : 03CH10-HY Condition : PEAK_74 3m HORN 91200-HF VERTICAL Detector : Peak Project : 7D2018-03 Mode : 7</p>

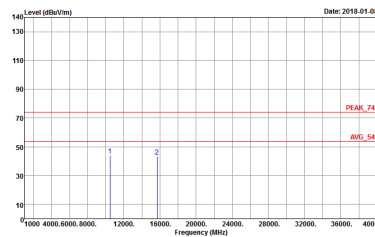
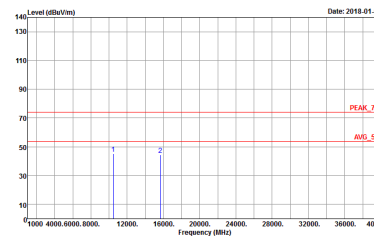

WIFI	Band 1 5150~5250MHz Harmonic @ 3m	
ANT	802.11n HT40 CH46 5230MHz	
1	Horizontal	Vertical
<p>Peak</p> <p>Avg.</p>	 <p>Site : 03CH10-11Y          Condition : PEAK_74 3m HORN 91200-HF HORIZONTAL          Detector : Peak          Project : 7D2018-03          Mode : S</p>	 <p>Site : 03CH10-11Y          Condition : PEAK_74 3m HORN 91200-HF VERTICAL          Detector : Peak          Project : 7D2018-03          Mode : S</p>



**Band 2 - 5250~5350MHz**  
**WIFI 802.11a (Band Edge @ 3m)**

WIFI	Band 2 5250~5350MHz Band Edge @ 3m	
ANT	802.11a CH52 5260MHz - L	
1	Horizontal	Fundamental
<b>Peak</b>	<p>Site : 03CH10-HY Condition : PEAK_BE_74 3m HORN 9120D-HF HORIZONTAL RBW:1000.000KHz VBW:3000.000KHz SWT:Auto Detector : Peak Project : 7D2018-03 Mode : 9 Setting : 13/1</p>	<p>Site : 03CH10-HY Condition : PEAK_74 3m HORN 9120D-HF HORIZONTAL RBW:1000.000KHz VBW:3000.000KHz SWT:Auto Detector : Peak Project : 7D2018-03 Mode : 9 Setting : 13/1</p>
<b>Avg.</b>	<p>Site : 03CH10-HY Condition : AV6_BE_54 3m HORN 9120D-HF HORIZONTAL RBW:1000.000KHz VBW:1000KHz SWT:Auto Detector : Peak Project : 7D2018-03 Mode : 9 Setting : 13/1</p>	<b>Left blank</b>

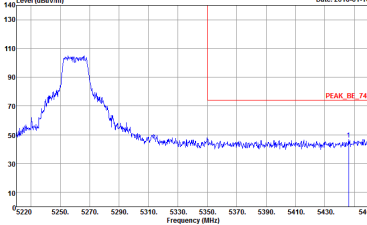
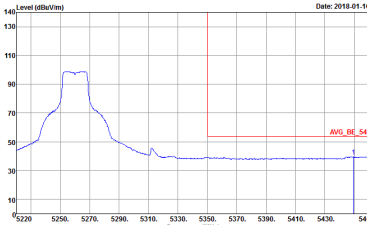

WIFI	Band 2 5250~5350MHz Band Edge @ 3m	
ANT	802.11a CH52 5260MHz - R	
1	Horizontal	Fundamental
<p><b>Peak</b></p>	 <p>Site : 03CH10-HY            Condition : PEAK_BE_74 3m HORN 91200-HF HORIZONTAL            : RBW:1000.000KHz VBW:3000.000KHz SWT:Auto            Detector : Peak            Project : 7D2018-03            Mode : 9            Setting : 13/1</p>	<p>Left blank</p>
<p><b>Avg.</b></p>	 <p>Site : 03CH10-HY            Condition : AVG_BE_54 3m HORN 91200-HF HORIZONTAL            : RBW:1000.000KHz VBW:1000KHz SWT:Auto            Detector : Peak            Project : 7D2018-03            Mode : 9            Setting : 13/1</p>	<p>Left blank</p>



WIFI	Band 2 5250~5350MHz Band Edge @ 3m	
ANT	802.11a CH52 5260MHz - L	
1	Vertical	Fundamental
<b>Peak</b>	<p>Site : 03CH10-HY            Condition : PEAK_BE_74 3m HORN 91200-HF VERTICAL            : RBW:1000.000KHz VBW:3000.000KHz SWT:Auto            Detector : Peak            Project : 7D2018-03            Mode : 9            Setting : 13/1</p>	<p>Site : 03CH10-HY            Condition : PEAK_74 3m HORN 91200-HF VERTICAL            : RBW:1000.000KHz VBW:3000.000KHz SWT:Auto            Detector : Peak            Project : 7D2018-03            Mode : 9            Setting : 13/1</p>
<b>Avg.</b>	<p>Site : 03CH10-HY            Condition : AVG_BE_54 3m HORN 91200-HF VERTICAL            : RBW:1000.000KHz VBW:1000KHz SWT:Auto            Detector : Peak            Project : 7D2018-03            Mode : 9            Setting : 13/1</p>	<b>Left blank</b>



WIFI	Band 2 5250~5350MHz Band Edge @ 3m	
ANT	802.11a CH52 5260MHz - R	
1	Vertical	Fundamental
Peak	<p>Site : 03CH10-HY Condition : PEAK_BE_74 3m HORN 91200-HF VERTICAL Detector : Peak Project : 7D2018-03 Mode : 9 Setting : 13/1</p>	Left blank
Avg.	<p>Site : 03CH10-HY Condition : AVG_BE_54 3m HORN 91200-HF VERTICAL Detector : Peak Project : 7D2018-03 Mode : 9 Setting : 13/1</p>	Left blank

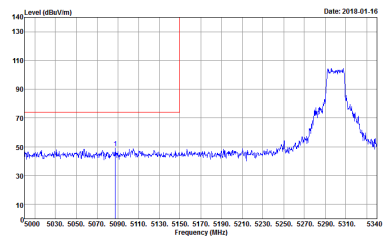
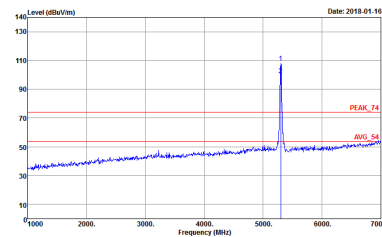
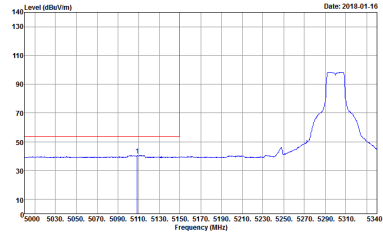

WIFI	Band 2 5250~5350MHz Band Edge @ 3m	
ANT	802.11a CH60 5300MHz - L	
1	Horizontal	Fundamental
<p><b>Peak</b></p>	 <p>Site : 03CH10-HY            Condition : PEAK_BE_74 3m HORN 9120D-HF HORIZONTAL            RBW:1000.000KHz VBW:3000.000KHz SWT:Auto            Detector : Peak            Project : 7D2018-03            Mode : 10            Setting : 13/1</p>	 <p>Site : 03CH10-HY            Condition : PEAK_74 3m HORN 9120D-HF HORIZONTAL            RBW:1000.000KHz VBW:3000.000KHz SWT:Auto            Detector : Peak            Project : 7D2018-03            Mode : 10            Setting : 13/1</p>
<p><b>Avg.</b></p>	 <p>Site : 03CH10-HY            Condition : AVG_BE_54 3m HORN 9120D-HF HORIZONTAL            RBW:1000.000KHz VBW:1000KHz SWT:Auto            Detector : Peak            Project : 7D2018-03            Mode : 10            Setting : 13/1</p>	<p><b>Left blank</b></p>

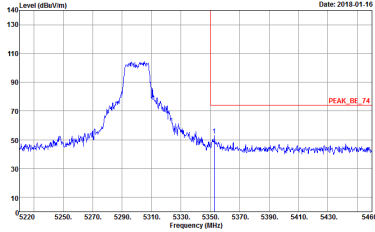
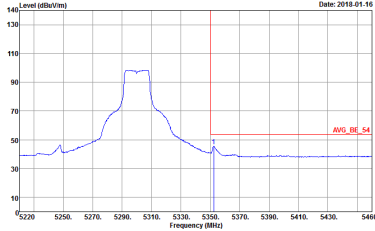

WIFI	Band 2 5250~5350MHz Band Edge @ 3m	
ANT	802.11a CH60 5300MHz - R	
1	Horizontal	Fundamental
<p><b>Peak</b></p>	 <p>Site : 03CH10-HY            Condition : PEAK_BE_74 3m HORN 91200-HF HORIZONTAL            RBW:1000.000KHz VBW:3000.000KHz SWT:Auto            Detector : Peak            Project : 7D2018-03            Mode : ID            Setting : 13/1</p>	<p>Left blank</p>
<p><b>Avg.</b></p>	 <p>Site : 03CH10-HY            Condition : AVG_BE_54 3m HORN 91200-HF HORIZONTAL            RBW:1000.000KHz VBW:1000KHz SWT:Auto            Detector : Peak            Project : 7D2018-03            Mode : ID            Setting : 13/1</p>	<p>Left blank</p>





WIFI	Band 2 5250~5350MHz Band Edge @ 3m	
ANT	802.11a CH60 5300MHz - L	
1	Vertical	Fundamental
<b>Peak</b>	<p>Site : 03CH10-HY            Condition : PEAK_BE_74 3m HORN 91200-HF VERTICAL            : RBW:1000.000KHz VBW:3000.000KHz SWT:Auto            Detector : Peak            Project : 7D2018-03            Mode : 10            Setting : 13/1</p>	<p>Site : 03CH10-HY            Condition : PEAK_74 3m HORN 91200-HF VERTICAL            : RBW:1000.000KHz VBW:3000.000KHz SWT:Auto            Detector : Peak            Project : 7D2018-03            Mode : 10            Setting : 13/1</p>
<b>Avg.</b>	<p>Site : 03CH10-HY            Condition : AVG_BE_54 3m HORN 91200-HF VERTICAL            : RBW:1000.000KHz VBW:1000KHz SWT:Auto            Detector : Peak            Project : 7D2018-03            Mode : 10            Setting : 13/1</p>	<b>Left blank</b>

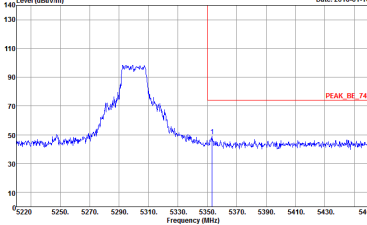
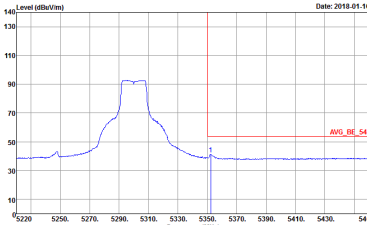

WIFI	Band 2 5250~5350MHz Band Edge @ 3m	
ANT	802.11a CH60 5300MHz - R	
1	Vertical	Fundamental
<p><b>Peak</b></p>	 <p>Site : 03CH10-HY            Condition : PEAK_BE_74 3m HORN 91200-HF VERTICAL            : RBW:1000.000KHz VBW:3000.000KHz SWT:Auto            Detector : Peak            Project : 7D2018-03            Mode : ID            Setting : 13/1</p>	<p>Left blank</p>
<p><b>Avg.</b></p>	 <p>Site : 03CH10-HY            Condition : AVG_BE_54 3m HORN 91200-HF VERTICAL            : RBW:1000.000KHz VBW:1000KHz SWT:Auto            Detector : Peak            Project : 7D2018-03            Mode : ID            Setting : 13/1</p>	<p>Left blank</p>

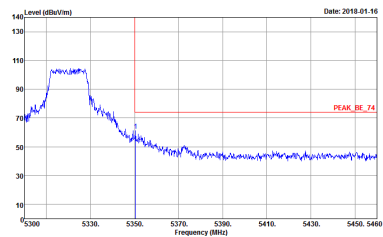
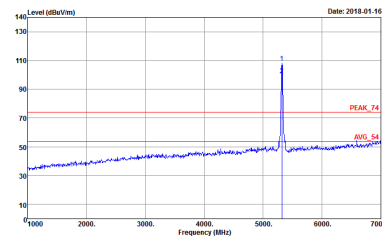
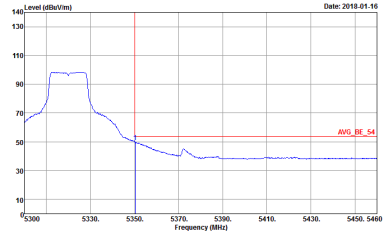

WIFI	Band 2 5250~5350MHz Band Edge @ 3m	
ANT	802.11a CH64 5320MHz	
1	Horizontal	Fundamental
Peak	 <p>Date: 2018-01-16</p> <p>Site : 03CH10-HY            Condition : PEAK_BE_74 3m HORN 9120D-HF HORIZONTAL            : RBW:1000.000KHz VBW:3000.000KHz SWT:Auto            Detector : Peak            Project : 7D2018-03            Mode : 11            Setting : 13/0</p>	 <p>Date: 2018-01-16</p> <p>Site : 03CH10-HY            Condition : PEAK_74 3m HORN 9120D-HF HORIZONTAL            : RBW:1000.000KHz VBW:3000.000KHz SWT:Auto            Detector : Peak            Project : 7D2018-03            Mode : 11            Setting : 13/0</p>
Avg.	 <p>Date: 2018-01-16</p> <p>Site : 03CH10-HY            Condition : AVG_BE_54 3m HORN 9120D-HF HORIZONTAL            : RBW:1000.000KHz VBW:1000KHz SWT:Auto            Detector : Peak            Project : 7D2018-03            Mode : 11            Setting : 13/0</p>	Left blank

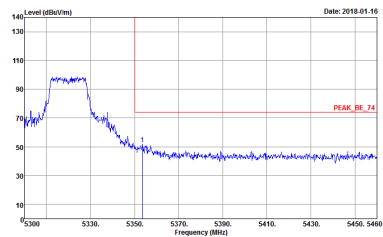
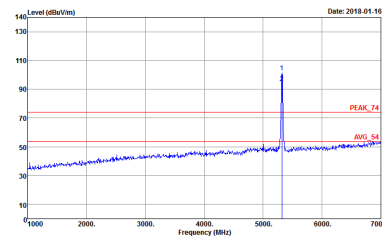
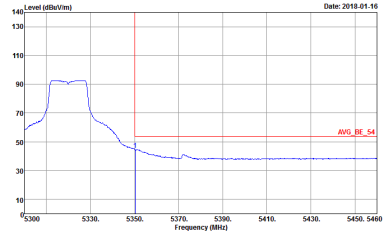

WIFI	Band 2 5250~5350MHz Band Edge @ 3m	
ANT	802.11a CH64 5320MHz	
1	Vertical	Fundamental
<p><b>Peak</b></p>	 <p>Site : 03CH10-HY          Condition : PEAK_BE_74 3m HORN 9120D-HF VERTICAL          RBW:1000.000KHz VBW:3000.000KHz SWT:Auto          Detector : Peak          Project : 7D2018-03          Mode : 11          Setting : 13/0</p>	 <p>Site : 03CH10-HY          Condition : PEAK_74 3m HORN 9120D-HF VERTICAL          RBW:1000.000KHz VBW:3000.000KHz SWT:Auto          Detector : Peak          Project : 7D2018-03          Mode : 11          Setting : 13/0</p>
<p><b>Avg.</b></p>	 <p>Site : 03CH10-HY          Condition : AVG_BE_54 3m HORN 9120D-HF VERTICAL          RBW:1000.000KHz VBW:1000KHz SWT:Auto          Detector : Peak          Project : 7D2018-03          Mode : 11          Setting : 13/0</p>	<p><b>Left blank</b></p>



**Band 2 5250~5350MHz**  
**WIFI 802.11n HT20 (Band Edge @ 3m)**

WIFI	Band 2 5250~5350MHz Band Edge @ 3m	
ANT	802.11n HT20 CH52 5260MHz - L	
1	Horizontal	Fundamental
<b>Peak</b>	<p>Site : 03CH10-HY            Condition : PEAK_BE_74 3m HORN 9120D-HF HORIZONTAL            RBW:1000.000KHz VBW:3000.000KHz SWT:Auto            Detector : Peak            Project : 7D2018-03            Mode : IZ</p>	<p>Site : 03CH10-HY            Condition : PEAK_74 3m HORN 9120D-HF HORIZONTAL            RBW:1000.000KHz VBW:3000.000KHz SWT:Auto            Detector : Peak            Project : 7D2018-03            Mode : IZ</p>
<b>Avg.</b>	<p>Site : 03CH10-HY            Condition : AVG_BE_54 3m HORN 9120D-HF HORIZONTAL            RBW:1000.000KHz VBW:1.000KHz SWT:Auto            Detector : Peak            Project : 7D2018-03            Mode : IZ</p>	<b>Left blank</b>

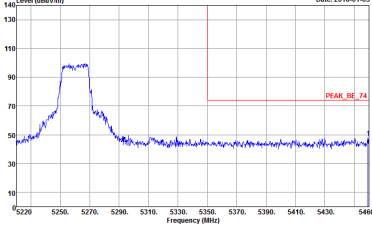
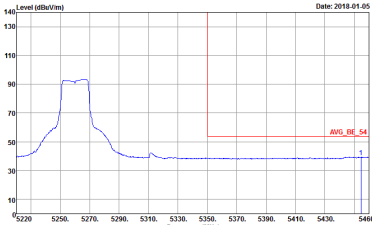

WIFI	Band 2 5250~5350MHz Band Edge @ 3m	
ANT	802.11n HT20 CH52 5260MHz - R	
1	Horizontal	Fundamental
Peak	 <p>Site : 03CH10-HY            Condition : PEAK_BE_74 3m HORN 91200-HF HORIZONTAL            Detector : Peak            Project : 7D2018-03            Mode : 12</p>	Left blank
Avg.	 <p>Site : 03CH10-HY            Condition : AVG_BE_54 3m HORN 91200-HF HORIZONTAL            Detector : Peak            Project : 7D2018-03            Mode : 12</p>	Left blank



WIFI	Band 2 5250~5350MHz Band Edge @ 3m	
ANT	802.11n HT20 CH52 5260MHz - L	
1	Vertical	Fundamental
Peak	<p>Site : 03CH10-HY            Condition : PEAK_BE_74 3m HORN 9120D-HF VERTICAL            RBW:1000.000KHz VBW:3000.000KHz SWT:Auto            Detector : Peak            Project : 7D2018-03            Mode : 12</p>	<p>Site : 03CH10-HY            Condition : PEAK_74 3m HORN 9120D-HF VERTICAL            RBW:1000.000KHz VBW:3000.000KHz SWT:Auto            Detector : Peak            Project : 7D2018-03            Mode : 12</p>
Avg.	<p>Site : 03CH10-HY            Condition : AVG_BE_54 3m HORN 9120D-HF VERTICAL            RBW:1000.000KHz VBW:1000KHz SWT:Auto            Detector : Peak            Project : 7D2018-03            Mode : 12</p>	Left blank



WIFI	Band 2 5250~5350MHz Band Edge @ 3m	
ANT	802.11n HT20 CH52 5260MHz - R	
1	Vertical	Fundamental
Peak	<p>Site : 03CH10-HY            Condition : PEAK_BE_74 3m HORN 91200-HF VERTICAL            : RBW:1000.000KHz VBW:3000.000KHz SWT:Auto            Detector : Peak            Project : 7D2018-03            Mode : 12</p>	Left blank
Avg.	<p>Site : 03CH10-HY            Condition : AVG_BE_54 3m HORN 91200-HF VERTICAL            : RBW:1000.000KHz VBW:1000KHz SWT:Auto            Detector : Peak            Project : 7D2018-03            Mode : 12</p>	Left blank





WIFI	Band 2 5250~5350MHz Band Edge @ 3m	
ANT	802.11n HT20 CH60 5300MHz - L	
1	Horizontal	Fundamental
<p><b>Peak</b></p>	<p>Site : 03CH10-HY            Condition : PEAK_BE_74 3m HORN 9120D-HF HORIZONTAL            Detector : Peak            Project : 7D2018-03            Mode : 13</p>	<p>Site : 03CH10-HY            Condition : PEAK_74 3m HORN 9120D-HF HORIZONTAL            Detector : Peak            Project : 7D2018-03            Mode : 13</p>
<p><b>Avg.</b></p>	<p>Site : 03CH10-HY            Condition : AVG_BE_54 3m HORN 9120D-HF HORIZONTAL            Detector : Peak            Project : 7D2018-03            Mode : 13</p>	<p><b>Left blank</b></p>

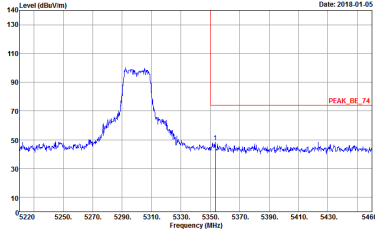
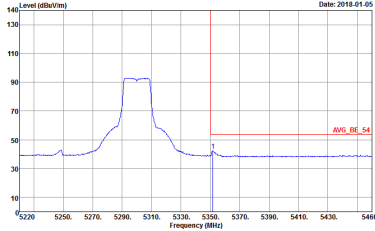

WIFI	Band 2 5250~5350MHz Band Edge @ 3m	
ANT	802.11n HT20 CH60 5300MHz - R	
1	Horizontal	Vertical
<p><b>Peak</b></p>	 <p>Site : 03CH10-HY          Condition : PEAK_BE_74 3m HORN 91200-HF HORIZONTAL          Detector : Peak          Project : 7D2018-03          Mode : 13</p>	<p>Left blank</p>
<p><b>Avg.</b></p>	 <p>Site : 03CH10-HY          Condition : AVG_BE_54 3m HORN 91200-HF HORIZONTAL          Detector : Peak          Project : 7D2018-03          Mode : 13</p>	<p>Left blank</p>



WIFI	Band 2 5250~5350MHz Band Edge @ 3m	
ANT	802.11n HT20 CH60 5300MHz - L	
1	Vertical	Fundamental
Peak	<p>Site : 03CH10-HY            Condition : PEAK_BE_74 3m HORN 91200-HF VERTICAL            : RBW:1000.000KHz VBW:3000.000KHz SWT:Auto            Detector : Peak            Project : 7D2018-03            Mode : 13</p>	<p>Site : 03CH10-HY            Condition : PEAK_74 3m HORN 91200-HF VERTICAL            : RBW:1000.000KHz VBW:3000.000KHz SWT:Auto            Detector : Peak            Project : 7D2018-03            Mode : 13</p>
Avg.	<p>Site : 03CH10-HY            Condition : AVG_BE_54 3m HORN 91200-HF VERTICAL            : RBW:1000.000KHz VBW:1000KHz SWT:Auto            Detector : Peak            Project : 7D2018-03            Mode : 13</p>	Left blank

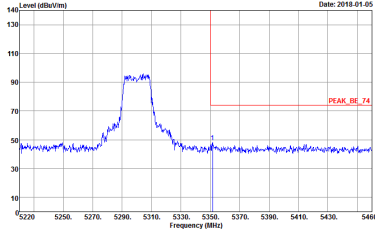
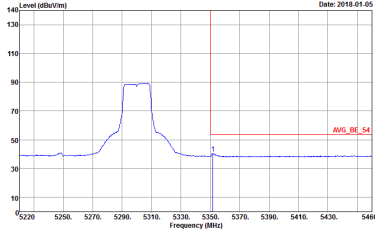

WIFI	Band 2 5250~5350MHz Band Edge @ 3m	
ANT	802.11n HT20 CH60 5300MHz - R	
1	Vertical	Fundamental
Peak	 <p>Site : 03CH10-HY            Condition : PEAK_BE_74 3m HORN 91200-HF VERTICAL            : RBW:1000.000KHz VBW:3000.000KHz SWT:Auto            Detector : Peak            Project : 7D2018-03            Mode : 13</p>	Left blank
Avg.	 <p>Site : 03CH10-HY            Condition : AVG_BE_54 3m HORN 91200-HF VERTICAL            : RBW:1000.000KHz VBW:1000KHz SWT:Auto            Detector : Peak            Project : 7D2018-03            Mode : 13</p>	Left blank

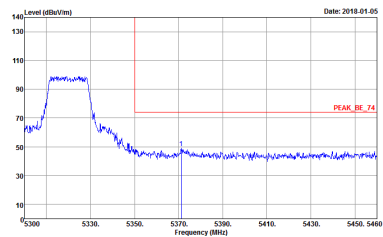
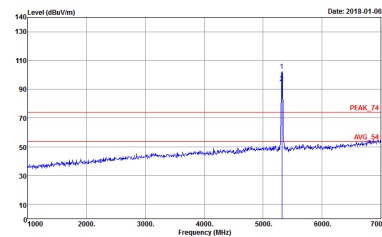
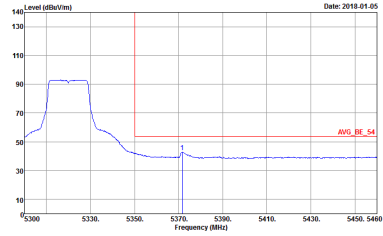

WIFI	Band 2 5250~5350MHz Band Edge @ 3m	
ANT	802.11n HT20 CH64 5320MHz	
1	Horizontal	Fundamental
<p><b>Peak</b></p>	 <p>Site : 03CH10-HY            Condition : PEAK_BE_74 3m HORN 9120D-HF HORIZONTAL            : RBW:1000.000KHz VBW:3000.000KHz SWT:Auto            Detector : Peak            Project : 7D2018-03            Mode : 14</p>	 <p>Site : 03CH10-HY            Condition : PEAK_74 3m HORN 9120D-HF HORIZONTAL            : RBW:1000.000KHz VBW:3000.000KHz SWT:Auto            Detector : Peak            Project : 7D2018-03            Mode : 14</p>
<p><b>Avg.</b></p>	 <p>Site : 03CH10-HY            Condition : AVG_BE_54 3m HORN 9120D-HF HORIZONTAL            : RBW:1000.000KHz VBW:1000KHz SWT:Auto            Detector : Peak            Project : 7D2018-03            Mode : 14</p>	<p>Left blank</p>



WIFI	Band 2 5250~5350MHz Band Edge @ 3m	
ANT	802.11n HT20 CH64 5320MHz	
1	Vertical	Fundamental
Peak	<p>Site : 03CH10-HY            Condition : PEAK_BE_74 3m HORN 9120D-HF VERTICAL            RBW:1000.000KHz VBW:3000.000KHz SWT:Auto            Detector : Peak            Project : 7D2018-03            Mode : 14</p>	<p>Site : 03CH10-HY            Condition : PEAK_74 3m HORN 9120D-HF VERTICAL            RBW:1000.000KHz VBW:3000.000KHz SWT:Auto            Detector : Peak            Project : 7D2018-03            Mode : 14</p>
	<p>Site : 03CH10-HY            Condition : AVG_BE_54 3m HORN 9120D-HF VERTICAL            RBW:1000.000KHz VBW:1000KHz SWT:Auto            Detector : Peak            Project : 7D2018-03            Mode : 14</p>	Left blank



**Band 2 5250~5350MHz**  
**WIFI 802.11n HT40 (Band Edge @ 3m)**

WIFI	Band 2 5250~5350MHz Band Edge @ 3m	
ANT	802.11n HT40 CH54 5270 MHz - L	
1	Horizontal	Fundamental
<b>Peak</b>	<p>Site : 03CH10-HY            Condition : PEAK_BE_74 3m HORN 9120D-HF HORIZONTAL            RBW:1000.000KHz VBW:3000.000KHz SWT:Auto            Detector : Peak            Project : 7D2018-03            Mode : 15</p>	<p>Site : 03CH10-HY            Condition : PEAK_74 3m HORN 9120D-HF HORIZONTAL            RBW:1000.000KHz VBW:3000.000KHz SWT:Auto            Detector : Peak            Project : 7D2018-03            Mode : 15</p>
<b>Avg.</b>	<p>Site : 03CH10-HY            Condition : AVG_BE_54 3m HORN 9120D-HF HORIZONTAL            RBW:1000.000KHz VBW:1.000KHz SWT:Auto            Detector : Peak            Project : 7D2018-03            Mode : 15</p>	<b>Left blank</b>

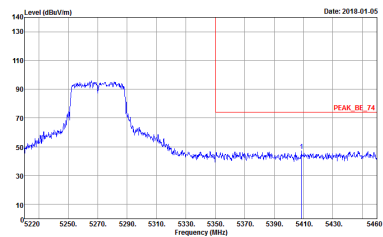
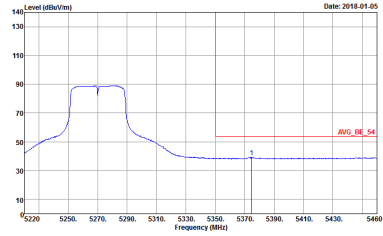

WIFI	Band 2 5250~5350MHz Band Edge @ 3m	
ANT	802.11n HT40 CH54 5270 MHz - R	
1	Horizontal	Fundamental
<p><b>Peak</b></p>	 <p>Site : 03CH10-HY            Condition : PEAK_BE_74 3m HORN 91200-HF HORIZONTAL            RBW:1000.000KHz VBW:3000.000KHz SWT:Auto            Detector : Peak            Project : 7D2018-03            Mode : IS</p>	<p>Left blank</p>
<p><b>Avg.</b></p>	 <p>Site : 03CH10-HY            Condition : AVG_BE_54 3m HORN 91200-HF HORIZONTAL            RBW:1000.000KHz VBW:1000KHz SWT:Auto            Detector : Peak            Project : 7D2018-03            Mode : IS</p>	<p>Left blank</p>





WIFI	Band 2 5250~5350MHz Band Edge @ 3m	
ANT	802.11n HT40 CH54 5270 MHz - L	
1	Vertical	Vertical
Peak	<p>Site : 03CH10-HY            Condition : PEAK_BE_74 3m HORN 91200-HF VERTICAL            : RBW:1000.000KHz VBW:3000.000KHz SWT:Auto            Detector : Peak            Project : 7D2018-03            Mode : 15</p>	<p>Site : 03CH10-HY            Condition : PEAK_74 3m HORN 91200-HF VERTICAL            : RBW:1000.000KHz VBW:3000.000KHz SWT:Auto            Detector : Peak            Project : 7D2018-03            Mode : 15</p>
Avg.	<p>Site : 03CH10-HY            Condition : AVG_BE_54 3m HORN 91200-HF VERTICAL            : RBW:1000.000KHz VBW:1000KHz SWT:Auto            Detector : Peak            Project : 7D2018-03            Mode : 15</p>	Left blank



WIFI	Band 2 5250~5350MHz Band Edge @ 3m	
ANT	802.11n HT40 CH54 5270 MHz - R	
1	Vertical	Vertical
Peak	<p>Site : 03CH10-HY            Condition : PEAK_BE_74 3m HORN 91200-HF VERTICAL            : RBW:1000.000KHz VBW:3000.000KHz SWT:Auto            Detector : Peak            Project : 7D2018-03            Mode : IS</p>	Left blank
Avg.	<p>Site : 03CH10-HY            Condition : AVG_BE_54 3m HORN 91200-HF VERTICAL            : RBW:1000.000KHz VBW:1000KHz SWT:Auto            Detector : Peak            Project : 7D2018-03            Mode : IS</p>	Left blank



WIFI	Band 2 5250~5350MHz Band Edge @ 3m	
ANT	802.11n HT40 CH62 5310 MHz - L	
1	Horizontal	Fundamental
Peak	<p>Site : 03CH10-HY            Condition : PEAK_BE_74 3m HORN 9120D-HF HORIZONTAL            RBW:1000.000KHz VBW:3000.000KHz SWT:Auto            Detector : Peak            Project : 7D2018-03            Mode : 16</p>	<p>Site : 03CH10-HY            Condition : PEAK_74 3m HORN 9120D-HF HORIZONTAL            RBW:1000.000KHz VBW:3000.000KHz SWT:Auto            Detector : Peak            Project : 7D2018-03            Mode : 16</p>
Avg.	<p>Site : 03CH10-HY            Condition : AVG_BE_54 3m HORN 9120D-HF HORIZONTAL            RBW:1000.000KHz VBW:1000KHz SWT:Auto            Detector : Peak            Project : 7D2018-03            Mode : 16</p>	Left blank

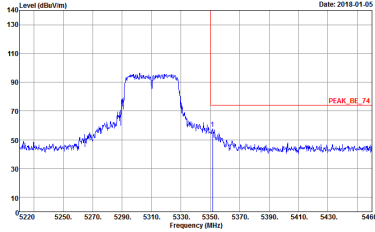
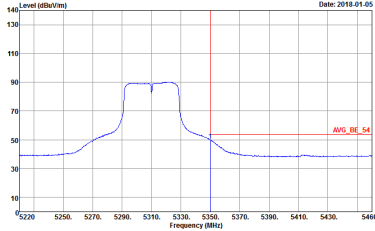

WIFI	Band 2 5250~5350MHz Band Edge @ 3m	
ANT	802.11n HT40 CH62 5310 MHz - R	
1	Horizontal	Fundamental
Peak	 <p>Site : 03CH10-HY            Condition : PEAK_BE_74 3m HORN 91200-HF HORIZONTAL            RBW:1000.000KHz VBW:3000.000KHz SWT:Auto            Detector : Peak            Project : 7D2018-03            Mode : 16</p>	Left blank
Avg.	 <p>Site : 03CH10-HY            Condition : AVG_BE_54 3m HORN 91200-HF HORIZONTAL            RBW:1000.000KHz VBW:1000KHz SWT:Auto            Detector : Peak            Project : 7D2018-03            Mode : 16</p>	Left blank



WIFI	Band 2 5250~5350MHz Band Edge @ 3m	
ANT	802.11n HT40 CH62 5310 MHz - L	
1	Vertical	Fundamental
Peak	<p>Site : 03CH10-HY            Condition : PEAK_BE_74 3m HORN 91200-HF VERTICAL            : RBW:1000.000KHz VBW:3000.000KHz SWT:Auto            Detector : Peak            Project : 7D2018-03            Mode : 16</p>	<p>Site : 03CH10-HY            Condition : PEAK_74 3m HORN 91200-HF VERTICAL            : RBW:1000.000KHz VBW:3000.000KHz SWT:Auto            Detector : Peak            Project : 7D2018-03            Mode : 16</p>
Avg.	<p>Site : 03CH10-HY            Condition : AVG_BE_54 3m HORN 91200-HF VERTICAL            : RBW:1000.000KHz VBW:1000KHz SWT:Auto            Detector : Peak            Project : 7D2018-03            Mode : 16</p>	Left blank

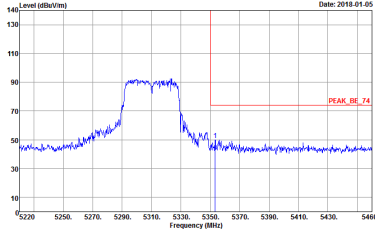
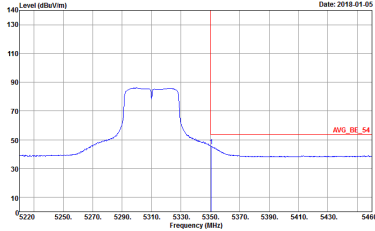

WIFI	Band 2 5250~5350MHz Band Edge @ 3m	
ANT	802.11n HT40 CH62 5310 MHz - R	
1	Vertical	Fundamental
<p><b>Peak</b></p>	 <p>Site : 03CH10-HY            Condition : PEAK_BE_74 3m HORN 91200-HF VERTICAL            : RBW:1000.000KHz VBW:3000.000KHz SWT:Auto            Detector : Peak            Project : 7D2018-03            Mode : 16</p>	<p>Left blank</p>
<p><b>Avg.</b></p>	 <p>Site : 03CH10-HY            Condition : AVG_BE_54 3m HORN 91200-HF VERTICAL            : RBW:1000.000KHz VBW:1000KHz SWT:Auto            Detector : Peak            Project : 7D2018-03            Mode : 16</p>	<p>Left blank</p>



**Band 2 - 5250~5350MHz**

**WIFI 802.11a (Harmonic @ 3m)**

WIFI	Band 2 5250~5350MHz Harmonic @ 3m	
ANT	802.11a CH52 5260MHz	
1	Horizontal	Vertical
<p><b>Peak</b></p> <p><b>Avg.</b></p>	<p>Site : 03CH10-HY            Condition : PEAK_74 3m HORN 91200-HF HORIZONTAL            Detector : Peak            Project : 7D2018-03            Mode : 9</p>	<p>Site : 03CH10-HY            Condition : PEAK_74 3m HORN 91200-HF VERTICAL            Detector : Peak            Project : 7D2018-03            Mode : 9</p>



WIFI	Band 2 5250~5350MHz Harmonic @ 3m	
ANT	802.11a CH60 5300MHz	
1	Horizontal	Vertical
Peak Avg.	<p>Site : 03CH10-11Y Condition : PEAK_74 3m HORN 91200-HF HORIZONTAL Detector : Peak Project : 7D2018-03 Mode : 10</p>	<p>Site : 03CH10-11Y Condition : PEAK_74 3m HORN 91200-HF VERTICAL Detector : Peak Project : 7D2018-03 Mode : 10</p>





WIFI	Band 2 5250~5350MHz Harmonic @ 3m	
ANT	802.11a CH64 5320MHz	
1	Horizontal	Vertical
Peak Avg.	<p>Site : 03CH10-11Y Condition : PEAK_74 3m HORN 91200-HF HORIZONTAL Detector : Peak Project : 7D2018-03 Mode : 11</p>	<p>Site : 03CH10-11Y Condition : PEAK_74 3m HORN 91200-HF VERTICAL Detector : Peak Project : 7D2018-03 Mode : 11</p>



**Band 2 5250~5350MHz  
WIFI 802.11n HT20 (Harmonic @ 3m)**

<b>WIFI</b>	<b>Band 2 5250~5350MHz Harmonic @ 3m</b>	
<b>ANT</b>	<b>802.11n HT20 CH52 5260MHz</b>	
<b>1</b>	<b>Horizontal</b>	<b>Vertical</b>
<b>Peak Avg.</b>	<p>Site : 03CH10-HY Condition : PEAK_74 3m HORN 91200-HF HORIZONTAL Detector : Peak Project : 7D2018-03 Mode : 12</p>	<p>Site : 03CH10-HY Condition : PEAK_74 3m HORN 91200-HF VERTICAL Detector : Peak Project : 7D2018-03 Mode : 12</p>



WIFI	Band 2 5250~5350MHz Harmonic @ 3m	
ANT	802.11n HT20 CH60 5300MHz	
1	Horizontal	Vertical
<p>Peak</p> <p>Avg.</p>	<p>Site : 03CH10-11Y          Condition : PEAK_74 3m HORN 91200-HF HORIZONTAL          Detector : Peak          Project : 7D2018-03          Mode : 13</p>	<p>Site : 03CH10-11Y          Condition : PEAK_74 3m HORN 91200-HF VERTICAL          Detector : Peak          Project : 7D2018-03          Mode : 13</p>



WIFI	Band 2 5250~5350MHz Harmonic @ 3m	
ANT	802.11n HT20 CH64 5320MHz	
1	Horizontal	Vertical
Peak Avg.	<p>Site : 03CH10-11Y Condition : PEAK_74 3m HORN 91200-HF HORIZONTAL Detector : Peak Project : 7D2018-03 Mode : 14</p>	<p>Site : 03CH10-11Y Condition : PEAK_74 3m HORN 91200-HF VERTICAL Detector : Peak Project : 7D2018-03 Mode : 14</p>



**Band 2 5250~5350MHz  
WIFI 802.11n HT40 (Harmonic @ 3m)**

<b>WIFI</b>	<b>Band 2 5250~5350MHz Harmonic @ 3m</b>	
<b>ANT</b>	<b>802.11n HT40 CH54 5270 MHz</b>	
<b>1</b>	<b>Horizontal</b>	<b>Vertical</b>
<b>Peak Avg.</b>	<p>Site : 03CH10-HY Condition : PEAK_74 3m HORN 91200-HF HORIZONTAL Detector : Peak Project : 7D2018-03 Mode : 15</p>	<p>Site : 03CH10-HY Condition : PEAK_74 3m HORN 91200-HF VERTICAL Detector : Peak Project : 7D2018-03 Mode : 15</p>



WIFI	Band 2 5250~5350MHz Harmonic @ 3m	
ANT	802.11n HT40 CH62 5310 MHz	
1	Horizontal	Vertical
<p>Peak</p> <p>Avg.</p>	<p>Site : 03CH10-11Y          Condition : PEAK_74 3m HORN 91200-HF HORIZONTAL          Detector : Peak          Project : 7D2018-03          Mode : 16</p>	<p>Site : 03CH10-11Y          Condition : PEAK_74 3m HORN 91200-HF VERTICAL          Detector : Peak          Project : 7D2018-03          Mode : 16</p>



**Band 3 - 5470~5725MHz**  
**WIFI 802.11a (Band Edge @ 3m)**

WIFI	Band 3 5470~5725MHz Band Edge @ 3m	
ANT	802.11a CH100 5500MHz	
1	Horizontal	Fundamental
<b>Peak</b>	<p>Site : 03CH10-HY            Condition : PEAK_BE_74 3m HORN 9120D-HF HORIZONTAL            RBW:1000.000KHz VBW:3000.000KHz SWT:Auto            Detector : Peak            Project : 7D2018-03            Mode : 17            Setting : 13/0</p>	<p>Site : 03CH10-HY            Condition : PEAK_74 3m HORN 9120D-HF HORIZONTAL            RBW:1000.000KHz VBW:3000.000KHz SWT:Auto            Detector : Peak            Project : 7D2018-03            Mode : 17            Setting : 13/0</p>
<b>Avg.</b>	<p>Site : 03CH10-HY            Condition : AV6_BE_54 3m HORN 9120D-HF HORIZONTAL            RBW:1000.000KHz VBW:1000KHz SWT:Auto            Detector : Peak            Project : 7D2018-03            Mode : 17            Setting : 13/0</p>	<b>Left blank</b>



WIFI	Band 3 5470~5725MHz Band Edge @ 3m	
ANT	802.11a CH100 5500MHz	
1	Vertical	Fundamental
<b>Peak</b>	<p>Site : 03CH10-HY            Condition : PEAK_BE_74 3m HORN 9120D-HF VERTICAL            : RBW:1000.000KHz VBW:3000.000KHz SWT:Auto            Detector : Peak            Project : 7D2018-03            Mode : 17            Setting : 13/0</p>	<p>Site : 03CH10-HY            Condition : PEAK_74 3m HORN 9120D-HF VERTICAL            : RBW:1000.000KHz VBW:3000.000KHz SWT:Auto            Detector : Peak            Project : 7D2018-03            Mode : 17            Setting : 13/0</p>
<b>Avg.</b>	<p>Site : 03CH10-HY            Condition : AVG_BE_54 3m HORN 9120D-HF VERTICAL            : RBW:1000.000KHz VBW:1000KHz SWT:Auto            Detector : Peak            Project : 7D2018-03            Mode : 17            Setting : 13/0</p>	<b>Left blank</b>



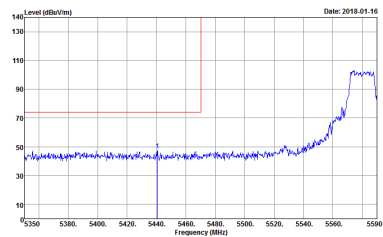
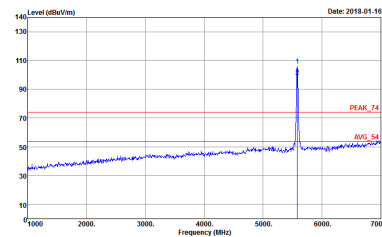
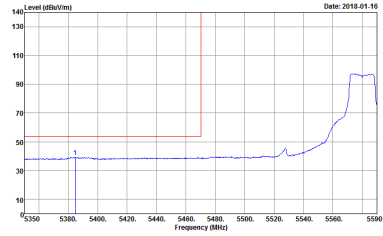

WIFI	Band 3 5470~5725MHz Band Edge @ 3m	
ANT	802.11a CH16 5580MHz - L	
1	Horizontal	Fundamental
<p><b>Peak</b></p>	 <p>Site : 03CH10-HY            Condition : PEAK_BE_74 3m HORN 91200-HF HORIZONTAL            RBW:1000.000KHz VBW:3000.000KHz SWT:Auto            Detector : Peak            Project : 7D2018-03            Mode : 1B            Setting : 10/0</p>	 <p>Site : 03CH10-HY            Condition : PEAK_74 3m HORN 91200-HF HORIZONTAL            RBW:1000.000KHz VBW:3000.000KHz SWT:Auto            Detector : Peak            Project : 7D2018-03            Mode : 1B            Setting : 10/0</p>
<p><b>Avg.</b></p>	 <p>Site : 03CH10-HY            Condition : AVG_BE_54 3m HORN 91200-HF HORIZONTAL            RBW:1000.000KHz VBW:1000KHz SWT:Auto            Detector : Peak            Project : 7D2018-03            Mode : 1B            Setting : 10/0</p>	<p><b>Left blank</b></p>

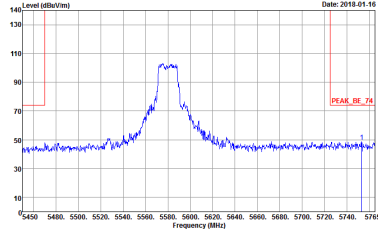
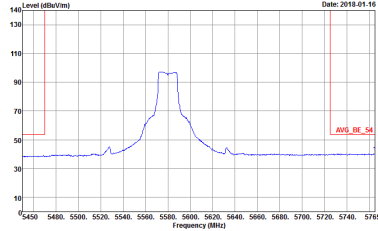

WIFI	Band 3 5470~5725MHz Band Edge @ 3m	
ANT	802.11a CH116 5580MHz - R	
1	Horizontal	Fundamental
<p><b>Peak</b></p>	 <p>Site : 03CH10-HY            Condition : PEAK_BE_74 3m HORN 91200-HF HORIZONTAL            RBW:1000.000KHz VBW:3000.000KHz SWT:Auto            Detector : Peak            Project : 7D2018-03            Mode : 1B            Setting : 10/0</p>	<p>Left blank</p>
<p><b>Avg.</b></p>	 <p>Site : 03CH10-HY            Condition : AVG_BE_54 3m HORN 91200-HF HORIZONTAL            RBW:1000.000KHz VBW:1000KHz SWT:Auto            Detector : Peak            Project : 7D2018-03            Mode : 1B            Setting : 10/0</p>	<p>Left blank</p>



WIFI	Band 3 5470~5725MHz Band Edge @ 3m	
ANT	802.11a CH16 5580MHz - L	
1	Vertical	Fundamental
<b>Peak</b>	<p>Site : 03CH10-HY            Condition : PEAK_BE_74 3m HORN 91200-HF VERTICAL            : RBW:1000.000KHz VBW:3000.000KHz SWT:Auto            Detector : Peak            Project : 7D2018-03            Mode : 1B            Setting : 10/0</p>	<p>Site : 03CH10-HY            Condition : PEAK_74 3m HORN 91200-HF VERTICAL            : RBW:1000.000KHz VBW:3000.000KHz SWT:Auto            Detector : Peak            Project : 7D2018-03            Mode : 1B            Setting : 10/0</p>
<b>Avg.</b>	<p>Site : 03CH10-HY            Condition : AVG_BE_54 3m HORN 91200-HF VERTICAL            : RBW:1000.000KHz VBW:1000KHz SWT:Auto            Detector : Peak            Project : 7D2018-03            Mode : 1B            Setting : 10/0</p>	<b>Left blank</b>

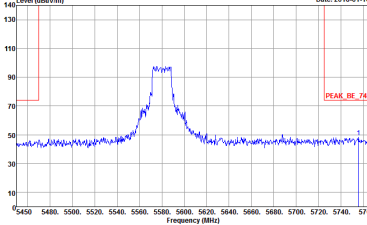
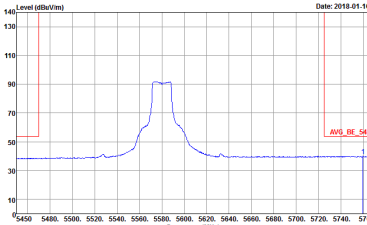

WIFI	Band 3 5470~5725MHz Band Edge @ 3m	
ANT	802.11a CH116 5580MHz - R	
1	Vertical	Fundamental
<p><b>Peak</b></p>	 <p>Site : 03CH10-HY            Condition : PEAK_BE_74 3m HORN 91200-HF VERTICAL            RBW:1000.000KHz VBW:3000.000KHz SWT:Auto            Detector : Peak            Project : 7D2018-03            Mode : 1B            Setting : 10/0</p>	<p>Left blank</p>
<p><b>Avg.</b></p>	 <p>Site : 03CH10-HY            Condition : AVG_BE_54 3m HORN 91200-HF VERTICAL            RBW:1000.000KHz VBW:1000KHz SWT:Auto            Detector : Peak            Project : 7D2018-03            Mode : 1B            Setting : 10/0</p>	<p>Left blank</p>



WIFI	Band 3 5470~5725MHz Band Edge @ 3m	
ANT	802.11a CH140 5700MHz	
1	Horizontal	Fundamental
Peak	<p>Site : 03CH10-14Y            Condition : PEAK_BE[UNII]_B3 3m HORN 9120D-HF HORIZONTAL            Detector : Peak            Project : 7D2018-03            Mode : 19            Setting : 9/0</p>	<p>Site : 03CH10-14Y            Condition : PEAK[UNII] 3m HORN 9120D-HF HORIZONTAL            Detector : Peak            Project : 7D2018-03            Mode : 19            Setting : 9/0</p>
Avg.	Left blank	Left blank



WIFI	Band 3 5470~5725MHz Band Edge @ 3m	
ANT	802.11a CH140 5700MHz	
1	Vertical	Fundamental
Peak	<p>Site : 03CH10-14V            Condition : PEAK_BE[UNII], B3 3m HORN 91200-HF VERTICAL            RBW:1000.000KHz VBW:3000.000KHz SWT:Auto            Detector : Peak            Project : 7D2018-03            Mode : 19            Setting : 9/0</p>	<p>Site : 03CH10-14V            Condition : PEAK[UNII] 3m HORN 91200-HF VERTICAL            RBW:1000.000KHz VBW:3000.000KHz SWT:Auto            Detector : Peak            Project : 7D2018-03            Mode : 19            Setting : 9/0</p>
Avg.	Left blank	Left blank



**Band 3 5470~5725MHz  
WIFI 802.11n HT20 (Band Edge @ 3m)**

WIFI	Band 3 5470~5725MHz Band Edge @ 3m	
ANT	802.11n HT20 CH100 5500MHz	
1	Horizontal	Fundamental
<b>Peak</b>	<p>Site : 03CH10-HY Condition : PEAK_BE_74 3m HORN 9120D-HF HORIZONTAL RBW:1000.000KHz VBW:3000.000KHz SWT:Auto Detector : Peak Project : 7D2018-03 Mode : Z0</p>	<p>Site : 03CH10-HY Condition : PEAK_74 3m HORN 9120D-HF HORIZONTAL RBW:1000.000KHz VBW:3000.000KHz SWT:Auto Detector : Peak Project : 7D2018-03 Mode : Z0</p>
<b>Avg.</b>	<p>Site : 03CH10-HY Condition : AVG_BE_54 3m HORN 9120D-HF HORIZONTAL RBW:1000.000KHz VBW:1.000KHz SWT:Auto Detector : Peak Project : 7D2018-03 Mode : Z0</p>	<b>Left blank</b>



WIFI	Band 3 5470~5725MHz Band Edge @ 3m	
ANT	802.11n HT20 CH100 5500MHz	
1	Vertical	Fundamental
<b>Peak</b>	<p>Site : 03CH10-HY            Condition : PEAK_BE_74 3m HORN 9120D-HF VERTICAL            : RBW:1000.000KHz VBW:3000.000KHz SWT:Auto            Detector : Peak            Project : 7D2018-03            Mode : Z0</p>	<p>Site : 03CH10-HY            Condition : PEAK_74 3m HORN 9120D-HF VERTICAL            : RBW:1000.000KHz VBW:3000.000KHz SWT:Auto            Detector : Peak            Project : 7D2018-03            Mode : Z0</p>
<b>Avg.</b>	<p>Site : 03CH10-HY            Condition : AVG_BE_54 3m HORN 9120D-HF VERTICAL            : RBW:1000.000KHz VBW:1000KHz SWT:Auto            Detector : Peak            Project : 7D2018-03            Mode : Z0</p>	<b>Left blank</b>





WIFI	Band 3 5470~5725MHz Band Edge @ 3m	
ANT	802.11n HT20 CH116 5580MHz - L	
1	Horizontal	Fundamental
Peak	<p>Site : 03CH10-HY            Condition : PEAK_BE_74 3m HORN 9120D-HF HORIZONTAL            RBW:1000.000KHz VBW:3000.000KHz SWT:Auto            Detector : Peak            Project : 7D2018-03            Mode : Z1</p>	<p>Site : 03CH10-HY            Condition : PEAK_74 3m HORN 9120D-HF HORIZONTAL            RBW:1000.000KHz VBW:3000.000KHz SWT:Auto            Detector : Peak            Project : 7D2018-03            Mode : Z1</p>
Avg.	<p>Site : 03CH10-HY            Condition : AVG_BE_54 3m HORN 9120D-HF HORIZONTAL            RBW:1000.000KHz VBW:1000KHz SWT:Auto            Detector : Peak            Project : 7D2018-03            Mode : Z1</p>	Left blank

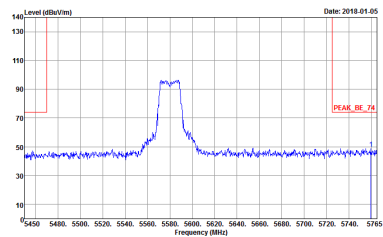
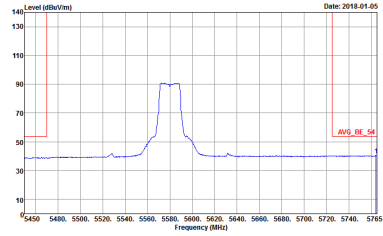

WIFI	Band 3 5470~5725MHz Band Edge @ 3m	
ANT	802.11n HT20 CH116 5580MHz - R	
1	Horizontal	Fundamental
Peak	 <p>           Site : 03CH10-HY            Condition : PEAK_BE_74 3m HORN 91200-HF HORIZONTAL            Detector : Peak            Project : 7D2018-03            Mode : Z1         </p>	Left blank
Avg.	 <p>           Site : 03CH10-HY            Condition : AVG_BE_54 3m HORN 91200-HF HORIZONTAL            Detector : Peak            Project : 7D2018-03            Mode : Z1         </p>	Left blank



WIFI	Band 3 5470~5725MHz Band Edge @ 3m	
ANT	802.11n HT20 CH116 5580MHz - L	
1	Vertical	Fundamental
<b>Peak</b>	<p>Site : 03CH10-HY            Condition : PEAK_BE_74 3m HORN 9120D-HF VERTICAL            RBW:1000.000KHz VBW:3000.000KHz SWT:Auto            Detector : Peak            Project : 7D2018-03            Mode : Z1</p>	<p>Site : 03CH10-HY            Condition : PEAK_74 3m HORN 9120D-HF VERTICAL            RBW:1000.000KHz VBW:3000.000KHz SWT:Auto            Detector : Peak            Project : 7D2018-03            Mode : Z1</p>
<b>Avg.</b>	<p>Site : 03CH10-HY            Condition : AVG_BE_54 3m HORN 9120D-HF VERTICAL            RBW:1000.000KHz VBW:1000KHz SWT:Auto            Detector : Peak            Project : 7D2018-03            Mode : Z1</p>	<b>Left blank</b>



WIFI	Band 3 5470~5725MHz Band Edge @ 3m	
ANT	802.11n HT20 CH116 5580MHz - R	
1	Vertical	Fundamental
Peak	<p>Site : 03CH10-HY            Condition : PEAK_BE_74 3m HORN 91200-HF VERTICAL            RBW:1000.000KHz VBW:3000.000KHz SWT:Auto            Detector : Peak            Project : 7D2018-03            Mode : Z1</p>	Left blank
Avg.	<p>Site : 03CH10-HY            Condition : AVG_BE_54 3m HORN 91200-HF VERTICAL            RBW:1000.000KHz VBW:1000KHz SWT:Auto            Detector : Peak            Project : 7D2018-03            Mode : Z1</p>	Left blank

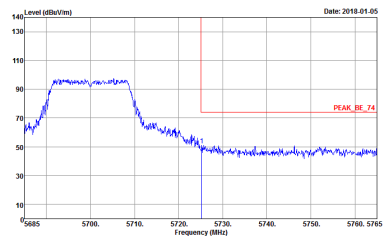
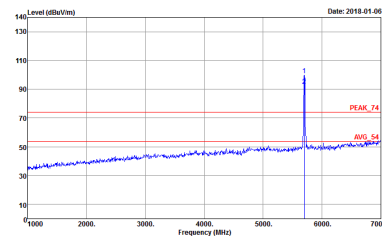
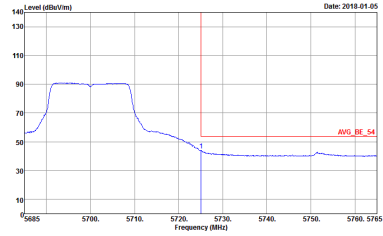

WIFI	Band 3 5470~5725MHz Band Edge @ 3m	
ANT	802.11n HT20 CH140 5700MHz	
1	Horizontal	Fundamental
<p><b>Peak</b></p>	 <p>Site : 03CH10-HY            Condition : PEAK_BE_74 3m HORN 9120D-HF HORIZONTAL            RBW:1000.000KHz VBW:3000.000KHz SWT:Auto            Detector : Peak            Project : 7D2018-03            Mode : ZZ</p>	 <p>Site : 03CH10-HY            Condition : PEAK_74 3m HORN 9120D-HF HORIZONTAL            RBW:1000.000KHz VBW:3000.000KHz SWT:Auto            Detector : Peak            Project : 7D2018-03            Mode : ZZ</p>
<p><b>Avg.</b></p>	 <p>Site : 03CH10-HY            Condition : AVG_BE_54 3m HORN 9120D-HF HORIZONTAL            RBW:1000.000KHz VBW:1000KHz SWT:Auto            Detector : Peak            Project : 7D2018-03            Mode : ZZ</p>	<p>Left blank</p>

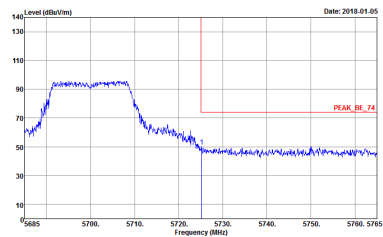
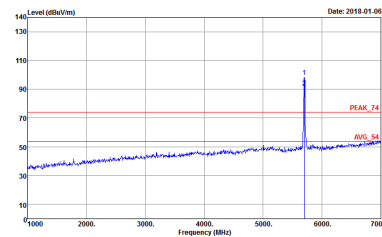
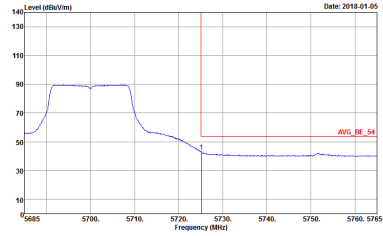

WIFI	Band 3 5470~5725MHz Band Edge @ 3m	
ANT	802.11n HT20 CH140 5700MHz	
1	Vertical	Fundamental
<p><b>Peak.</b></p>	 <p>Site : 03CH10-HY            Condition : PEAK_BE_74 3m HORN 9120D-HF VERTICAL            RBW:1000.000KHz VBW:3000.000KHz SWT:Auto            Detector : Peak            Project : 7D2018-03            Mode : ZZ</p>	 <p>Site : 03CH10-HY            Condition : PEAK_74 3m HORN 9120D-HF VERTICAL            RBW:1000.000KHz VBW:3000.000KHz SWT:Auto            Detector : Peak            Project : 7D2018-03            Mode : ZZ</p>
<p><b>Avg.</b></p>	 <p>Site : 03CH10-HY            Condition : AVG_BE_54 3m HORN 9120D-HF VERTICAL            RBW:1000.000KHz VBW:1000KHz SWT:Auto            Detector : Peak            Project : 7D2018-03            Mode : ZZ</p>	<p>Left blank</p>

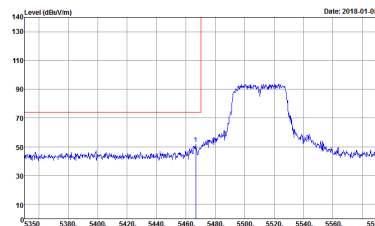
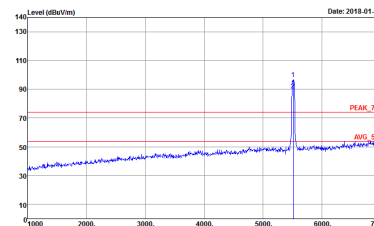
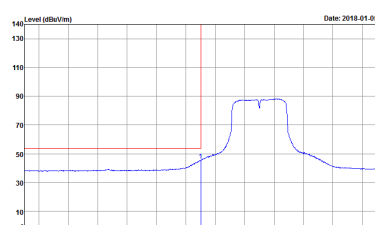

**Band 3 5470~5725MHz  
WIFI 802.11n HT40 (Band Edge @ 3m)**

WIFI	Band 3 5470~5725MHz Band Edge @ 3m	
ANT	802.11n HT40 CH102 5510MHz - L	
1	Horizontal	Fundamental
<p><b>Peak</b></p>	 <p>Site : 03CH10-HY Condition : PEAK_BE_74 3m HORN 9120D-HF HORIZONTAL RBW:1000.000KHz VBW:3000.000KHz SWT:Auto Detector : Peak Project : 7D2018-03 Mode : Z3</p>	 <p>Site : 03CH10-HY Condition : PEAK_74 3m HORN 9120D-HF HORIZONTAL RBW:1000.000KHz VBW:3000.000KHz SWT:Auto Detector : Peak Project : 7D2018-03 Mode : Z3</p>
<p><b>Avg.</b></p>	 <p>Site : 03CH10-HY Condition : AVG_BE_54 3m HORN 9120D-HF HORIZONTAL RBW:1000.000KHz VBW:1.000KHz SWT:Auto Detector : Peak Project : 7D2018-03 Mode : Z3</p>	<p><b>Left blank</b></p>

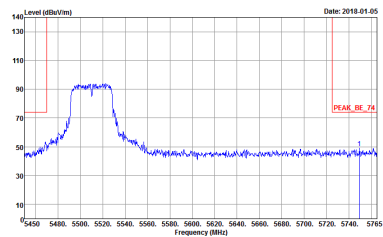
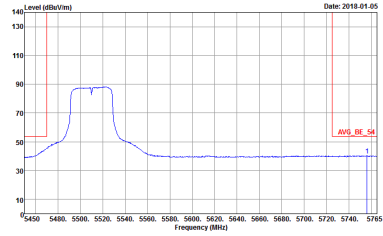

WIFI	Band 3 5470~5725MHz Band Edge @ 3m	
ANT	802.11n HT40 CH102 5510MHz - R	
1	Horizontal	Fundamental
<p><b>Peak</b></p>	 <p>Site : 03CH10-HY            Condition : PEAK_BE_74 3m HORN 91200-HF HORIZONTAL            Detector : Peak            Project : 7D2018-03            Mode : Z3</p>	<p>Left blank</p>
<p><b>Avg.</b></p>	 <p>Site : 03CH10-HY            Condition : AVG_BE_54 3m HORN 91200-HF HORIZONTAL            Detector : Peak            Project : 7D2018-03            Mode : Z3</p>	<p>Left blank</p>





WIFI	Band 3 5470~5725MHz Band Edge @ 3m	
ANT	802.11n HT40 CH102 5510MHz - L	
1	Vertical	Fundamental
<b>Peak</b>	<p>Site : 03CH10-HY            Condition : PEAK_BE_74 3m HORN 9120D-HF VERTICAL            Detector : Peak            Project : 7D2018-03            Mode : Z3</p>	<p>Site : 03CH10-HY            Condition : PEAK_74 3m HORN 9120D-HF VERTICAL            Detector : Peak            Project : 7D2018-03            Mode : Z3</p>
<b>Avg.</b>	<p>Site : 03CH10-HY            Condition : AVG_BE_54 3m HORN 9120D-HF VERTICAL            Detector : Peak            Project : 7D2018-03            Mode : Z3</p>	<b>Left blank</b>

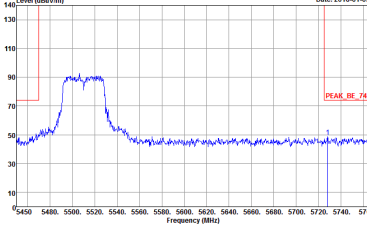
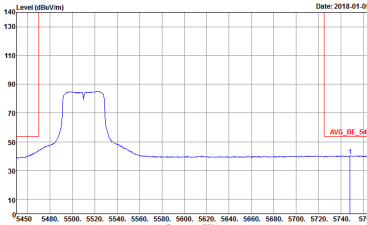

WIFI	Band 3 5470~5725MHz Band Edge @ 3m	
ANT	802.11n HT40 CH102 5510MHz - R	
1	Vertical	Fundamental
Peak	 <p>Site : 03CH10-HY            Condition : PEAK_BE_74 3m HORN 91200-HF VERTICAL            Detector : Peak            Project : 7D2018-03            Mode : Z3</p>	Left blank
Avg.	 <p>Site : 03CH10-HY            Condition : AVG_BE_54 3m HORN 91200-HF VERTICAL            Detector : Peak            Project : 7D2018-03            Mode : Z3</p>	Left blank

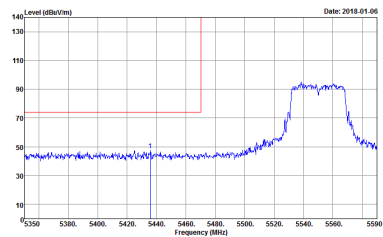
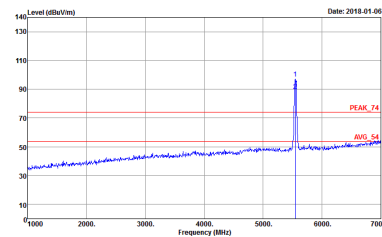
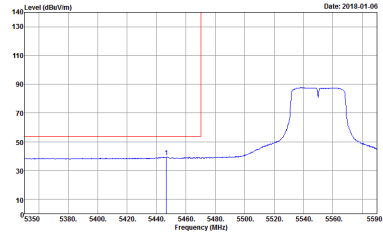

WIFI	Band 3 5470~5725MHz Band Edge @ 3m	
ANT	802.11n HT40 CH110 5550MHz - L	
1	Horizontal	Fundamental
<p><b>Peak</b></p>	 <p>Site : 03CH10-HY            Condition : PEAK_BE_74 3m HORN 9120D-HF HORIZONTAL            RBW:1000.000KHz VBW:3000.000KHz SWT:Auto            Detector : Peak            Project : 7D2018-03            Mode : Z4</p>	 <p>Site : 03CH10-HY            Condition : PEAK_74 3m HORN 9120D-HF HORIZONTAL            RBW:1000.000KHz VBW:3000.000KHz SWT:Auto            Detector : Peak            Project : 7D2018-03            Mode : Z4</p>
<p><b>Avg.</b></p>	 <p>Site : 03CH10-HY            Condition : AVG_BE_54 3m HORN 9120D-HF HORIZONTAL            RBW:1000.000KHz VBW:1000KHz SWT:Auto            Detector : Peak            Project : 7D2018-03            Mode : Z4</p>	<p><b>Left blank</b></p>

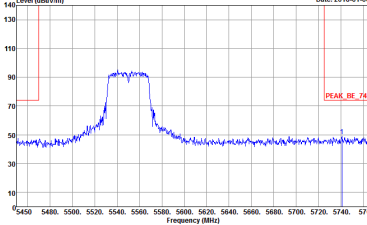
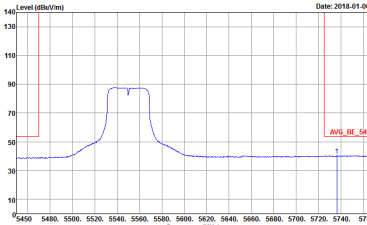

WIFI	Band 3 5470~5725MHz Band Edge @ 3m	
ANT	802.11n HT40 CH110 5550MHz - R	
1	Horizontal	Fundamental
<p><b>Peak</b></p>	 <p>Site : 03CH10-HY            Condition : PEAK_BE_74 3m HORN 91200-HF HORIZONTAL            Detector : Peak            Project : 7D2018-03            Mode : 24</p>	<p>Left blank</p>
<p><b>Avg.</b></p>	 <p>Site : 03CH10-HY            Condition : AVG_BE_54 3m HORN 91200-HF HORIZONTAL            Detector : Peak            Project : 7D2018-03            Mode : 24</p>	<p>Left blank</p>



WIFI	Band 3 5470~5725MHz Band Edge @ 3m	
ANT	802.11n HT40 CH110 5550MHz - L	
1	Vertical	Fundamental
<b>Peak</b>	<p>Site : 03CH10-HY            Condition : PEAK_BE_74 3m HORN 91200-HF VERTICAL            RBW:1000.000KHz VBW:3000.000KHz SWT:Auto            Detector : Peak            Project : 7D2018-03            Mode : Z4</p>	<p>Site : 03CH10-HY            Condition : PEAK_74 3m HORN 91200-HF VERTICAL            RBW:1000.000KHz VBW:3000.000KHz SWT:Auto            Detector : Peak            Project : 7D2018-03            Mode : Z4</p>
<b>Avg.</b>	<p>Site : 03CH10-HY            Condition : AVG_BE_54 3m HORN 91200-HF VERTICAL            RBW:1000.000KHz VBW:1000KHz SWT:Auto            Detector : Peak            Project : 7D2018-03            Mode : Z4</p>	<b>Left blank</b>

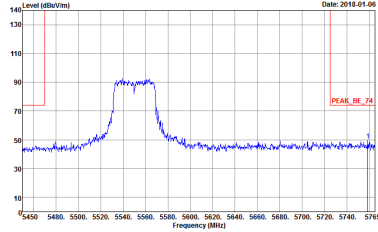
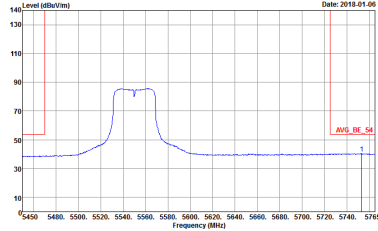

WIFI	Band 3 5470~5725MHz Band Edge @ 3m	
ANT	802.11n HT40 CH110 5550MHz - R	
1	Vertical	Fundamental
Peak	 <p>Site : 03CH10-HY            Condition : PEAK_BE_74 3m HORN 91200-HF VERTICAL            Detector : Peak            Project : 7D2018-03            Mode : 24</p>	Left blank
Avg.	 <p>Site : 03CH10-HY            Condition : AVG_BE_54 3m HORN 91200-HF VERTICAL            Detector : Peak            Project : 7D2018-03            Mode : 24</p>	Left blank

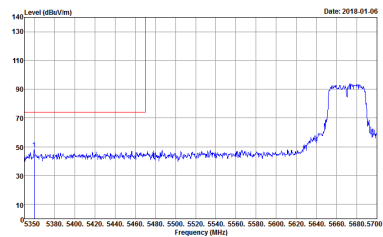
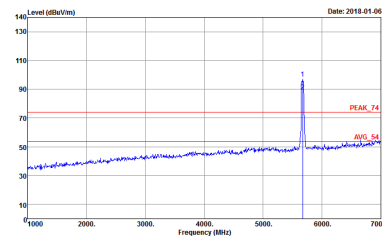
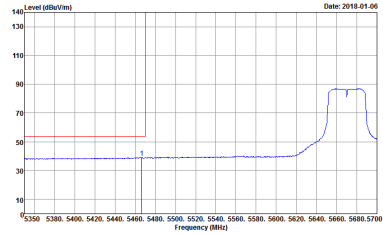

WIFI	Band 3 5470~5725MHz Band Edge @ 3m	
ANT	802.11n HT40 CH134 5670MHz - L	
1	Horizontal	Fundamental
Peak	 <p>Site : 03CH10-HY            Condition : PEAK_BE_74 3m HORN 9120D-HF HORIZONTAL            RBW:1000.000KHz VBW:3000.000KHz SWT:Auto            Detector : Peak            Project : 7D2018-03            Mode : Z5</p>	 <p>Site : 03CH10-HY            Condition : PEAK_74 3m HORN 9120D-HF HORIZONTAL            RBW:1000.000KHz VBW:3000.000KHz SWT:Auto            Detector : Peak            Project : 7D2018-03            Mode : Z5</p>
Avg.	 <p>Site : 03CH10-HY            Condition : AVG_BE_54 3m HORN 9120D-HF HORIZONTAL            RBW:1000.000KHz VBW:1000KHz SWT:Auto            Detector : Peak            Project : 7D2018-03            Mode : Z5</p>	Left blank

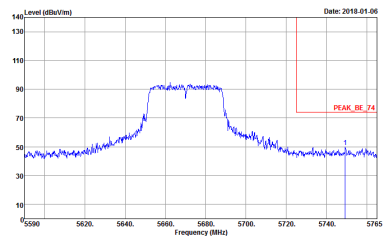
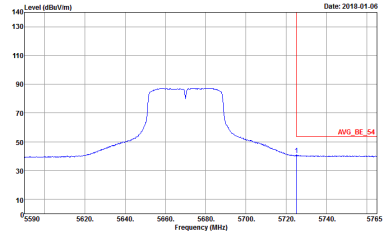

WIFI	Band 3 5470~5725MHz Band Edge @ 3m	
ANT	802.11n HT40 CH134 5670MHz - R	
1	Horizontal	Fundamental
Peak	 <p>Site : 03CH10-HY  Condition : PEAK_BE_74 3m HORN 91200-HF HORIZONTAL  RBW:1000.000KHz VBW:3000.000KHz SWT:Auto  Detector : Peak  Project : 7D2018-03  Mode : Z5</p>	Left blank
Avg.	 <p>Site : 03CH10-HY  Condition : AVG_BE_54 3m HORN 91200-HF HORIZONTAL  RBW:1000.000KHz VBW:1000KHz SWT:Auto  Detector : Peak  Project : 7D2018-03  Mode : Z5</p>	Left blank





WIFI	Band 3 5470~5725MHz Band Edge @ 3m	
ANT	802.11n HT40 CH134 5670MHz - L	
1	Vertical	Fundamental
Peak	<p>Site : 03CH10-HY            Condition : PEAK_BE_74 3m HORN 9120D-HF VERTICAL            RBW:1000.000KHz VBW:3000.000KHz SWT:Auto            Detector : Peak            Project : 7D2018-03            Mode : Z5</p>	<p>Site : 03CH10-HY            Condition : PEAK_74 3m HORN 9120D-HF VERTICAL            RBW:1000.000KHz VBW:3000.000KHz SWT:Auto            Detector : Peak            Project : 7D2018-03            Mode : Z5</p>
Avg.	<p>Site : 03CH10-HY            Condition : AVG_BE_54 3m HORN 9120D-HF VERTICAL            RBW:1000.000KHz VBW:1000KHz SWT:Auto            Detector : Peak            Project : 7D2018-03            Mode : Z5</p>	Left blank

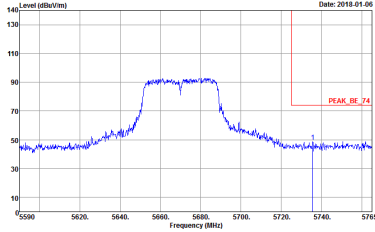
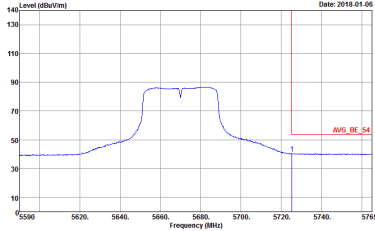

WIFI	Band 3 5470~5725MHz Band Edge @ 3m	
ANT	802.11n HT40 CH134 5670MHz - R	
1	Vertical	Fundamental
<p><b>Peak</b></p>	 <p>Site : 03CH10-HY            Condition : PEAK_BE_74 3m HORN 91200-HF VERTICAL            : RBW:1000.000KHz VBW:3000.000KHz SWT:Auto            Detector : Peak            Project : 7D2018-03            Mode : Z5</p>	<p>Left blank</p>
<p><b>Avg.</b></p>	 <p>Site : 03CH10-HY            Condition : AVG_BE_54 3m HORN 91200-HF VERTICAL            : RBW:1000.000KHz VBW:1000KHz SWT:Auto            Detector : Peak            Project : 7D2018-03            Mode : Z5</p>	<p>Left blank</p>



**Band 3 - 5470~5725MHz**

**WIFI 802.11a (Harmonic @ 3m)**

WIFI	Band 3 5470~5725MHz Harmonic @ 3m	
ANT	802.11a CH100 5500MHz	
1	Horizontal	Vertical
<p><b>Peak</b></p> <p><b>Avg.</b></p>	<p>Site : 03CH10-11Y            Condition : PEAK_74 3m HORN 91200-1HF HORIZONTAL            Detector : Peak            Project : 7D2018-03            Mode : 17</p>	<p>Site : 03CH10-11Y            Condition : PEAK_74 3m HORN 91200-1HF VERTICAL            Detector : Peak            Project : 7D2018-03            Mode : 17</p>



WIFI	Band 3 5470~5725MHz Harmonic @ 3m	
ANT	802.11a CH116 5580MHz	
1	Horizontal	Vertical
<b>Peak</b> <b>Avg.</b>	<p>Site : 03CH10-11Y Condition : PEAK_74 3m HORN 91200-HF HORIZONTAL Detector : Peak Project : 7b2018-03 Mode : 18</p>	<p>Site : 03CH10-11Y Condition : PEAK_74 3m HORN 91200-HF VERTICAL Detector : Peak Project : 7b2018-03 Mode : 18</p>

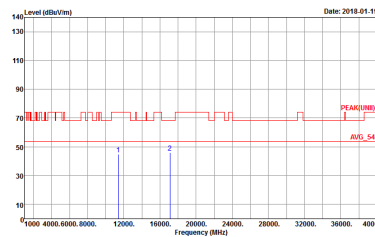
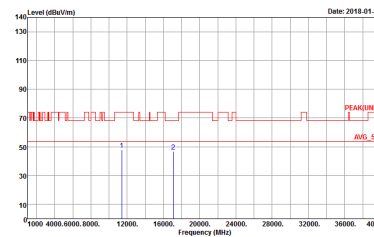

WIFI	Band 3 5470~5725MHz Harmonic @ 3m	
ANT	802.11a CH140 5700MHz	
1	Horizontal	Vertical
<p>Peak</p> <p>Avg.</p>	 <p>Site : 03CH10-11Y          Condition : PEAK(LINE) 3m HORN 91200-HF HORIZONTAL          Detector : Peak          Project : 7D2018-03          Mode : 20</p>	 <p>Site : 03CH10-11Y          Condition : PEAK(LINE) 3m HORN 91200-HF VERTICAL          Detector : Peak          Project : 7D2018-03          Mode : 20</p>



**Band 3 5470~5725MHz  
WIFI 802.11n HT20 (Harmonic @ 3m)**

<b>WIFI</b>	<b>Band 3 5470~5725MHz Harmonic @ 3m</b>	
<b>ANT</b>	<b>802.11n HT20 CH100 5500MHz</b>	
<b>1</b>	<b>Horizontal</b>	<b>Vertical</b>
<b>Peak Avg.</b>	<p>Site : 03CH10-HY Condition : PEAK_74 3m HORN 91200-HF HORIZONTAL Detector : Peak Project : 7D2018-03 Mode : 20</p>	<p>Site : 03CH10-HY Condition : PEAK_74 3m HORN 91200-HF VERTICAL Detector : Peak Project : 7D2018-03 Mode : 20</p>

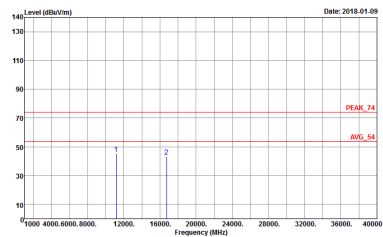
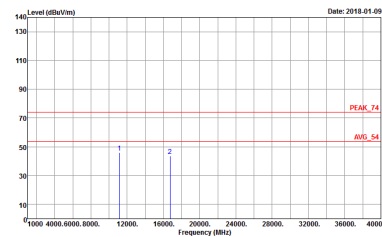

WIFI	Band 3 5470~5725MHz Harmonic @ 3m	
ANT	802.11n HT20 CH116 5580MHz	
1	Horizontal	Vertical
<p>Peak</p> <p>Avg.</p>	 <p>Site : 03CH10-11Y          Condition : PEAK_74 3m HORN 91200-HF HORIZONTAL          Detector : Peak          Project : 7D2018-03          Mode : Z1</p>	 <p>Site : 03CH10-11Y          Condition : PEAK_74 3m HORN 91200-HF VERTICAL          Detector : Peak          Project : 7D2018-03          Mode : Z1</p>

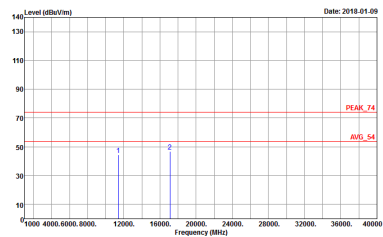
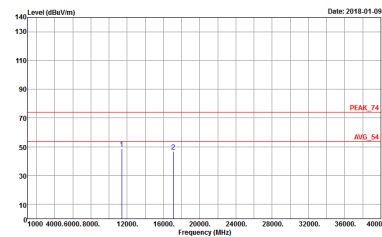

WIFI	Band 3 5470~5725MHz Harmonic @ 3m	
ANT	802.11n HT20 CH140 5700MHz	
1	Horizontal	Vertical
<p>Peak</p> <p>Avg.</p>	 <p>Site : 03CH10-11Y          Condition : PEAK_74 3m HORN 91200-HF HORIZONTAL          Detector : Peak          Project : 7D2018-03          Mode : Z2</p>	 <p>Site : 03CH10-11Y          Condition : PEAK_74 3m HORN 91200-HF VERTICAL          Detector : Peak          Project : 7D2018-03          Mode : Z2</p>





**Band 3 5470~5725MHz  
WIFI 802.11n HT40 (Harmonic @ 3m)**

<b>WIFI</b>	<b>Band 3 5470~5725MHz Harmonic @ 3m</b>	
<b>ANT</b>	<b>802.11n HT40 CH102 5510MHz</b>	
<b>1</b>	<b>Horizontal</b>	<b>Vertical</b>
<b>Peak Avg.</b>	<p>Site : 03CH10-HY Condition : PEAK_74 3m HORN 91200-HF HORIZONTAL Detector : Peak Project : 7D2018-03 Mode : Z3</p>	<p>Site : 03CH10-HY Condition : PEAK_74 3m HORN 91200-HF VERTICAL Detector : Peak Project : 7D2018-03 Mode : Z3</p>

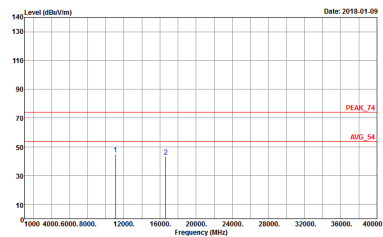
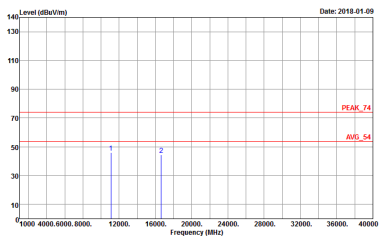

WIFI	Band 3 5470~5725MHz Harmonic @ 3m	
ANT	802.11n HT40 CH110 5550MHz	
1	Horizontal	Vertical
<p>Peak</p> <p>Avg.</p>	 <p>Site : 03CH10-11Y          Condition : PEAK_74 3m HORN 91200-HF HORIZONTAL          Detector : Peak          Project : 7D2018-03          Mode : -24</p>	 <p>Site : 03CH10-11Y          Condition : PEAK_74 3m HORN 91200-HF VERTICAL          Detector : Peak          Project : 7D2018-03          Mode : -24</p>



WIFI	Band 3 5470~5725MHz Harmonic @ 3m	
ANT	802.11n HT40 CH134 5670MHz	
1	Horizontal	Vertical
<p>Peak</p> <p>Avg.</p>	<p>Site : 03CH10-11Y          Condition : PEAK_74 3m HORN 91200-HF HORIZONTAL          Detector : Peak          Project : 7D2018-03          Mode : 25</p>	<p>Site : 03CH10-11Y          Condition : PEAK_74 3m HORN 91200-HF VERTICAL          Detector : Peak          Project : 7D2018-03          Mode : 25</p>



Emission below 1GHz  
5GHz WIFI 802.11n HT40 (LF)

WIFI	5GHz WIFI	
ANT	802.11n HT40 LF	
1	Horizontal	Vertical
QP / Peak	<p>Site : 03CH10-HY Condition : QP 3m BE-LOG 6111D-LF HORIZONTAL Detector : Peak Project : 7D2018-03 Mode : Z6</p>	<p>Site : 03CH10-HY Condition : QP 3m BE-LOG 6111D-LF VERTICAL Detector : Peak Project : 7D2018-03 Mode : Z6</p>



## Appendix E. Duty Cycle Plots

Band	Duty Cycle (%)	T(us)	1/T(kHz)	VBW Setting	Duty Factor(dB)
802.11a	87.26	1370.00	0.73	1kHz	0.59
5GHz 802.11n HT20	86.49	1280.00	0.78	1kHz	0.63
5GHz 802.11n HT40	89.66	1820.00	0.55	1kHz	0.47

### 802.11a

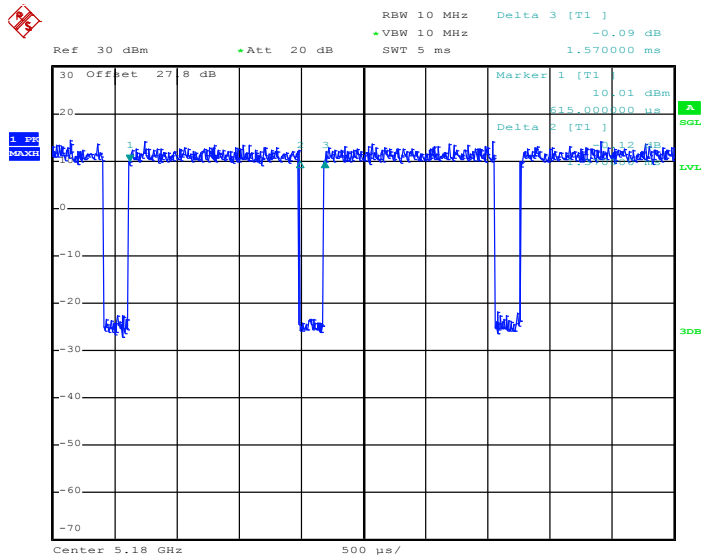

Date: 4.JAN.2018 15:02:24



802.11n HT20

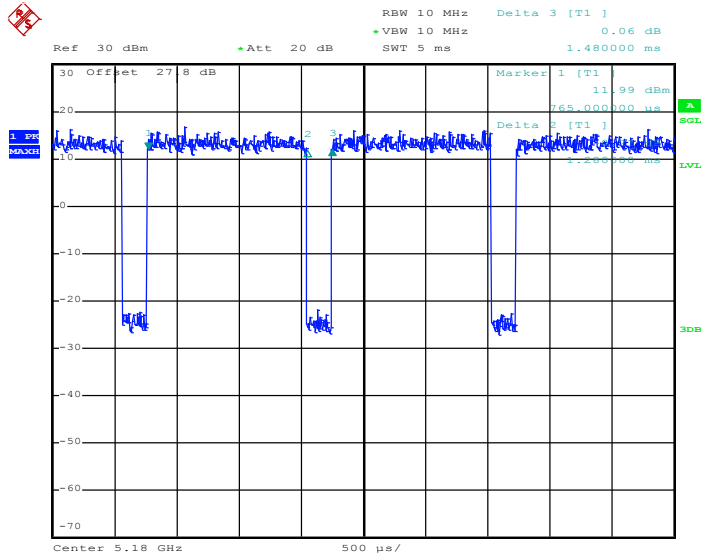

Date: 4.JAN.2018 15:50:44

802.11n HT40

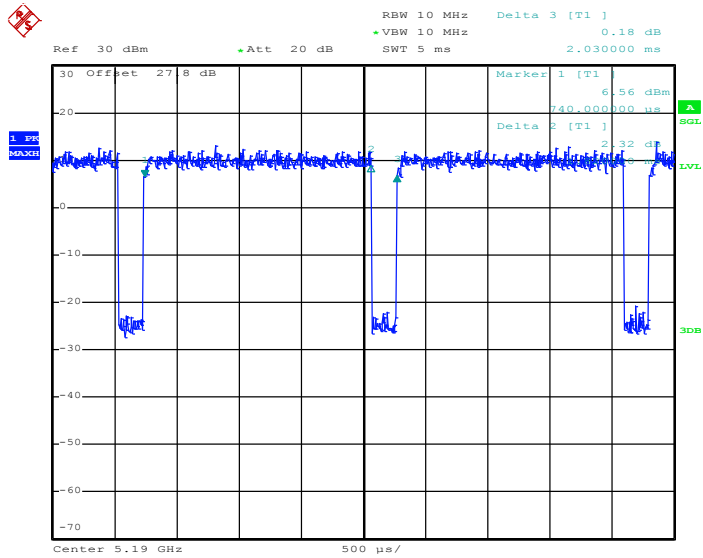

Date: 4.JAN.2018 16:27:32