



FCC RF Test Report

APPLICANT : Motorola Mobility LLC
EQUIPMENT : Mobile Cellular Phone
BRAND NAME : Motorola
MODEL NAME : XT1921-5, XT1921-3
FCC ID : IHDT56XC2
STANDARD : 47 CFR Part 2, 27
CLASSIFICATION : PCS Licensed Transmitter Held to Ear (PCE)

This is partial report. The product was received on Dec. 20, 2017 and completely tested on Mar. 08, 2018. We, Sporton International (Kunshan) Inc., would like to declare that the tested sample has been evaluated in accordance with the test procedures given in ANSI / TIA-603-E and has been in compliance with the applicable technical standards.

This report contains data that were produced under subcontract by Laboratory SPORTON INTERNATIONAL INC.

The test results in this report apply exclusively to the tested model / sample. Without written approval of Sporton International (Kunshan) Inc., the test report shall not be reproduced except in full.

James Huang



Approved by: James Huang / Manager

Sporton International (Kunshan) Inc.

No.3-2 Ping-Xiang Rd, Kunshan Development Zone Kunshan City Jiangsu Province 215335 China



TABLE OF CONTENTS

REVISION HISTORY..... 3

SUMMARY OF TEST RESULT 4

1 GENERAL DESCRIPTION 5

 1.1 Applicant 5

 1.2 Manufacturer 5

 1.3 Product Feature of Equipment Under Test..... 5

 1.4 Product Specification of Equipment Under Test..... 6

 1.5 Modification of EUT 6

 1.6 Emission Designator 6

 1.7 Testing Location 7

 1.8 Applicable Standards..... 7

2 TEST CONFIGURATION OF EQUIPMENT UNDER TEST 8

 2.1 Test Mode 8

 2.2 Connection Diagram of Test System 10

 2.3 Support Unit used in test configuration and system 10

 2.4 Measurement Results Explanation Example 10

 2.5 Frequency List of Low/Middle/High Channels 11

3 CONDUCTED TEST ITEMS 13

 3.1 Measuring Instruments 13

 3.2 Test Setup 13

 3.3 Test Result of Conducted Test 13

 3.4 Conducted Output Power and EIRP 14

 3.5 Peak-to-Average Ratio 15

 3.6 Occupied Bandwidth 16

 3.7 Conducted Band Edge 17

 3.8 Conducted Spurious Emission 18

 3.9 Frequency Stability 19

4 RADIATED TEST ITEMS 20

 4.1 Measuring Instruments 20

 4.2 Test Setup 20

 4.3 Test Result of Radiated Test 20

 4.4 Radiated Spurious Emission 21

5 LIST OF MEASURING EQUIPMENT 22

6 UNCERTAINTY OF EVALUATION 23

APPENDIX A. TEST RESULTS OF CONDUCTED TEST

APPENDIX B. TEST RESULTS OF EIRP AND RADIATED TEST

APPENDIX C. TEST SETUP PHOTOGRAPHS



SUMMARY OF TEST RESULT

Report Section	FCC Rule	Description	Limit	Result	Remark
3.4	§2.1046	Conducted Output Power	Reporting Only	PASS	-
	§27.50(h)(2)	Equivalent Isotropic Radiated Power (Band 41)	EIRP < 2Watt		
3.5	N/A	Peak-to-Average Ratio	<13 dB	PASS	-
3.6	§2.1049	Occupied Bandwidth	Reporting Only	PASS	-
3.7	§27.53(m)(4)	Conducted Band Edge Measurement (Band 41)	§27.53(m)(4)	PASS	-
3.8	§2.1051 §27.53(m)(4)	Conducted Spurious Emission (Band 41)	< 55+10log ₁₀ (P[Watts])	PASS	-
3.9	§2.1055 §27.54	Frequency Stability Temperature & Voltage	Within Authorized Band	PASS	-
4.4	§2.1053 §27.53(m)(4)	Radiated Spurious Emission (Band 41)	< 55+10log ₁₀ (P[Watts])	PASS	Under limit 28.88 dB at 8012.000 MHz



1 General Description

1.1 Applicant

Motorola Mobility LLC
222 W. Merchandise Mart Plaza, Chicago IL 60654, USA

1.2 Manufacturer

Motorola Mobility LLC
222 W. Merchandise Mart Plaza, Chicago IL 60654, USA

1.3 Product Feature of Equipment Under Test

Product Feature	
Equipment	Mobile Cellular Phone
Brand Name	Motorola
Model Name	XT1921-5, XT1921-3
FCC ID	IHDT56XC2
IMEI Code	351841090026461 (for Radiation) 990005440087469 (for Conducted)
EUT supports Radios application	CDMA/EV-DO/GSM/EGPRS/WCDMA/HSPA/LTE/FM/GNSS WLAN 11b/g/n HT20 WLAN 11a/n HT20/HT40 Bluetooth BR/EDR/LE
HW Version	DVT1B
EUT Stage	Identical Prototype

Remark: The above EUT's information was declared by manufacturer. Please refer to the specifications or user's manual for more detailed description.

Accessory List	
AC Adapter 1	Brand Name : Motorola
	Model Name : C-P35
AC Adapter 2	Brand Name : Motorola
	Model Name : SSW-2919UMTJ C-P35 SPN5945A
AC Adapter 3	Brand Name : Motorola
	Model Name : C-P56
AC Adapter 4	Brand Name : Motorola
	Model Name : C-P56
Battery	Brand Name : Motorola
	Model Name : GK40
USB Cable	Brand Name : Saibao
	Model Name : SWT-A083A



1.4 Product Specification of Equipment Under Test

Standards-related Product Specification	
Tx Frequency	LTE Band 41: 2498.5 MHz ~ 2687.5 MHz
Rx Frequency	LTE Band 41: 2498.5 MHz ~ 2687.5 MHz
Bandwidth	LTE Band 41: 5MHz / 10MHz / 15MHz / 20MHz
Maximum Output Power to Antenna	LTE Band 41 : 24.48 dBm
Antenna Gain	LTE Band 41 : 1.45 dBi
Antenna Type	PIFA Antenna and Coupling Type (LDS) Antenna
Type of Modulation	QPSK / 16QAM / 64QAM

1.5 Modification of EUT

No modifications are made to the EUT during all test items.

1.6 Emission Designator

LTE Band 41		QPSK			16QAM			64QAM		
BW (MHz)	Frequency Range (MHz)	Emission Designator (99%OBW)	Frequency Tolerance (ppm)	Maximum EIRP(W)	Emission Designator (99%OBW)	Frequency Tolerance (ppm)	Maximum EIRP(W)	Emission Designator (99%OBW)	Frequency Tolerance (ppm)	Maximum EIRP(W)
5	2498.5 ~ 2687.5	4M49G7D	-	0.3707	4M50W7D	-	0.3206	4M50W7D	-	0.2564
10	2501.0 ~ 2685.0	9M03G7D	0.0022	0.3917	9M05W7D	-	0.3184	9M05W7D	-	0.2594
15	2503.5 ~ 2682.5	13M5G7D	-	0.3758	13M4W7D	-	0.3184	13M5W7D	-	0.2500
20	2506.0 ~ 2680.0	18M5G7D	-	0.3837	18M3W7D	-	0.3192	18M4W7D	-	0.2606

LTE Band 41_CA		QPSK		16QAM		64QAM		
CA Combination BW (MHz) PCC/SCC	Primary Component Carrier Frequency Range (MHz)	Secondary Component Carrier Frequency Range (MHz)	Emission Designator (99%OBW)	Maximum EIRP(W)	Emission Designator (99%OBW)	Maximum EIRP(W)	Emission Designator (99%OBW)	Maximum EIRP(W)
20 + 20	2506.0 ~ 2660.2	2525.8 ~ 2680.0	37M6G7D	0.3381	37M5W7D	0.2871	37M5W7D	0.2393
20 + 15	2506.0 ~ 2665.1	2523.1 ~ 2682.2	32M9G7D	0.2871	32M8W7D	0.2729	32M9W7D	0.2123
15 + 20	2503.8 ~ 2662.9	2520.9 ~ 2680.0	32M7G7D	0.2831	32M7W7D	0.2729	32M8W7D	0.2099
20 + 10	2506.0 ~ 2670.1	2520.4 ~ 2684.5	28M1G7D	0.2838	28M0W7D	0.2786	28M0W7D	0.2113
10 + 20	2501.5 ~ 2665.6	2515.9 ~ 2680.0	28M1G7D	0.2786	27M9W7D	0.2729	27M9W7D	0.2104
20 + 5	2506.0 ~ 2675.0	2517.7 ~ 2686.7	23M4G7D	0.2786	23M3W7D	0.2692	23M4W7D	0.2143
5 + 20	2499.3 ~ 2668.3	2511.0 ~ 2680.0	23M3G7D	0.2767	23M3W7D	0.2761	23M4W7D	0.2061
15 + 15	2503.5 ~ 2667.5	2518.5 ~ 2682.5	28M7G7D	0.2793	28M5W7D	0.2735	28M6W7D	0.2089



1.7 Testing Location

Sporton International (Kunshan) Inc. is accredited to ISO 17025 by National Voluntary Laboratory Accreditation Program (NVLAP code: 600155-0) and the FCC designation No. is CN5013.

Test Site	Sporton International (Kunshan) Inc.		
Test Site Location	No.3-2 Ping-Xiang Rd, Kunshan Development Zone Kunshan City Jiangsu Province 215335 China TEL : +86-512-57900158 FAX : +86-512-57900958		
Test Site No.	Sporton Site No.		FCC Test Firm Registration No.
	TH01-KS	03CH03-KS	630927

1.8 Applicable Standards

According to the specifications of the manufacturer, the EUT must comply with the requirements of the following standards:

- 47 CFR Part 2, 27
- ANSI / TIA-603-E
- FCC KDB 971168 D01 Power Meas. License Digital Systems v03
- FCC KDB 412172 D01 Determining ERP and EIRP v01r01

Remark:

1. All test items were verified and recorded according to the standards and without any deviation during the test.
2. This EUT has also been tested and complied with the requirements of FCC Part 15, Subpart B, Subpart B, recorded in a separate test report.



2 Test Configuration of Equipment Under Test

2.1 Test Mode

Antenna port conducted and radiated test items listed below are performed according to KDB 971168 D01 Power Meas. License Digital Systems v03 with maximum output power.

Radiated measurements are performed by rotating the EUT in three different orthogonal test planes to find the maximum emission.

Test Items	Band	Bandwidth (MHz)						Modulation			RB #			Test Channel		
		1.4	3	5	10	15	20	QPSK	16QAM	64QAM	1	Half	Full	L	M	H
Max. Output Power	41	-	-	v	v	v	v	v	v	v	v	v	v	v	v	v
Peak-to-Average Ratio	41	-	-				v	v	v	v	v		v	v	v	
26dB and 99% Bandwidth	41	-	-	v	v	v	v	v	v	v			v	v	v	
Conducted Band Edge	41	-	-	v	v	v	v	v	v	v	v		v		v	
Conducted Spurious Emission	41	-	-	v	v	v	v	v	v	v	v			v	v	
Frequency Stability	41	-	-		v			v					v		v	
E.R.P / E.I.R.P	41	-	-	v	v	v	v	v	v	v	v			v	v	
Radiated Spurious Emission	3`	Worst Case											v	v	v	
Note	<ol style="list-style-type: none"> The mark "v" means that this configuration is chosen for testing The mark "-" means that this bandwidth is not supported. The device is investigated from 30MHz to 10 times of fundamental signal for radiated spurious emission test under different RB size/offset and modulations in exploratory test. Subsequently, only the worst case emissions are reported. All the radiated test cases were performance with Adapter 1. 															



Test Items	Band	Bandwidth (MHz)										Modulation			RB #			Test Channel		
		20+20	20+15	15+20	20+10	10+20	20+5	5+20	15+15	15+10	10+15	QPSK	16QAM	64QAM	1	Half	Full	L	M	H
Max. Output Power	41_CA	v	v	v	v	v	v	v	v			v	v	v	v	v	v	v	v	v
26dB and 99% Bandwidth	41_CA	v	v	v	v	v	v	v	v			v	v	v			v	v	v	v
Conducted Band Edge	41_CA	v	v	v	v	v	v	v	v			v	v	v	v		v	v		v
Conducted Spurious Emission	41_CA	v	v	v	v	v	v	v	v			v	v	v	v			v	v	v
E.I.R.P.	41_CA	v	v	v	v	v	v	v	v			v	v	v	v			v	v	v
Radiated Spurious Emission	41_CA	Worst Case															v	v	v	
Note	<ol style="list-style-type: none"> The mark "v " means that this configuration is chosen for testing The mark "- " means that this bandwidth is not supported. The device is investigated from 30MHz to 10 times of fundamental signal for radiated spurious emission test under different RB size/offset and modulations in exploratory test. Subsequently, only the worst case emissions are reported. All the radiated test cases were performance with Adapter 1. 																			

2.2 Connection Diagram of Test System

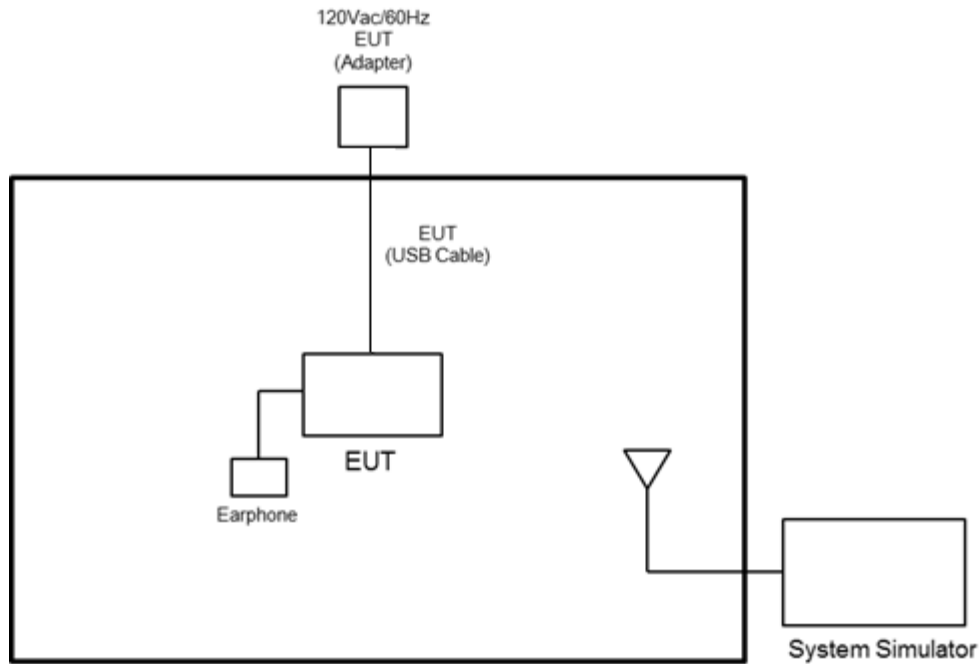

2.3 Support Unit used in test configuration and system

Item	Equipment	Trade Name	Model No.	FCC ID	Data Cable	Power Cord
1.	System Simulator	Anritsu	MT8820C	N/A	N/A	Unshielded, 1.8 m
2.	Earphone	N/A	N/A	N/A	N/A	N/A

2.4 Measurement Results Explanation Example

For all conducted test items:

The offset level is set in the spectrum analyzer to compensate the RF cable loss and attenuator factor between EUT conducted output port and spectrum analyzer. With the offset compensation, the spectrum analyzer reading level is exactly the EUT RF output level.

The spectrum analyzer offset is derived from RF cable loss and attenuator factor.

Offset = RF cable loss + attenuator factor.

Following shows an offset computation example with cable loss 4.2 dB and 10dB attenuator.

Example :

$$\begin{aligned} \text{Offset(dB)} &= \text{RF cable loss(dB)} + \text{attenuator factor(dB)} \\ &= 4.2 + 10 = 14.2 \text{ (dB)} \end{aligned}$$



2.5 Frequency List of Low/Middle/High Channels

LTE Band 41 Channel and Frequency List				
BW [MHz]	Channel/Frequency(MHz)	Lowest	Middle	Highest
20	Channel	39750	40620	41490
	Frequency	2506	2593	2680
15	Channel	39725	40620	41515
	Frequency	2503.5	2593	2682.5
10	Channel	39700	40620	41540
	Frequency	2501	2593	2685
5	Channel	39675	40620	41565
	Frequency	2498.5	2593	2687.5

LTE Band 41 Channel and Frequency List					
BW [MHz]	Channel/Frequency(MHz)	Lowest	Middle	Highest	
20 + 20	PCC	Channel	39750	40521	41292
		Frequency	2506.0	2583.1	2660.2
	SCC	Channel	39948	40719	41490
		Frequency	2525.8	2602.9	2680.0
20 + 15	PCC	Channel	39750	40546	41341
		Frequency	2506.0	2585.6	2665.1
	SCC	Channel	39921	40717	41512
		Frequency	2523.1	2602.7	2682.2
15 + 20	PCC	Channel	39728	40523	41319
		Frequency	2503.8	2593.3	2662.9
	SCC	Channel	39899	40694	41490
		Frequency	2520.9	2600.4	2680.0
20 + 10	PCC	Channel	39750	40571	41391
		Frequency	2506.0	2588.1	2670.1
	SCC	Channel	39894	40715	41535
		Frequency	2520.4	2602.5	2684.5
10 + 20	PCC	Channel	39705	40526	41346
		Frequency	2501.5	2583.6	2665.6
	SCC	Channel	39849	40670	41490
		Frequency	2515.9	2598.0	2680.0



LTE Band 41 Channel and Frequency List					
20 + 5	PCC	Channel	39750	40595	41440
		Frequency	2506.0	2590.5	2675.0
	SCC	Channel	39867	40712	41557
		Frequency	2517.7	2602.2	2686.7
5 + 20	PCC	Channel	39683	40528	41373
		Frequency	2499.3	2583.8	2668.3
	SCC	Channel	39800	40645	41490
		Frequency	2511.0	2595.5	2680.0
15 + 15	PCC	Channel	39725	40545	41365
		Frequency	2503.5	2585.5	2667.5
	SCC	Channel	39875	40695	41515
		Frequency	2518.5	2600.5	2682.5

3 Conducted Test Items

3.1 Measuring Instruments

See list of measuring instruments of this test report.

3.2 Test Setup

3.2.1 Conducted Output Power

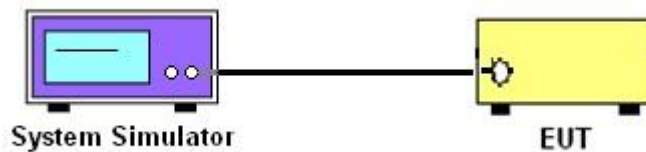

3.2.2 Peak-to-Average Ratio, Occupied Bandwidth ,Conducted Band-Edge and Conducted Spurious Emission

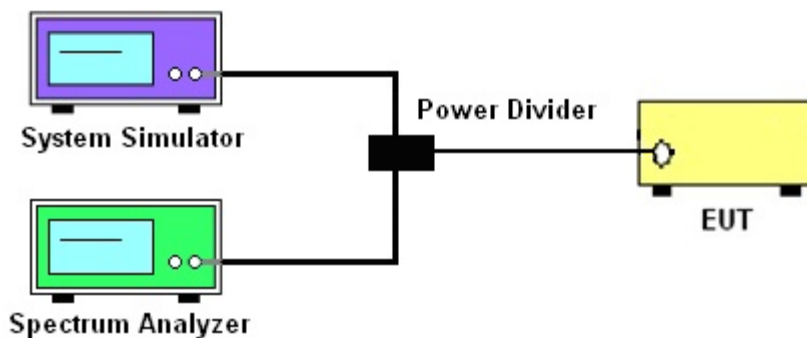

3.2.3 Frequency Stability

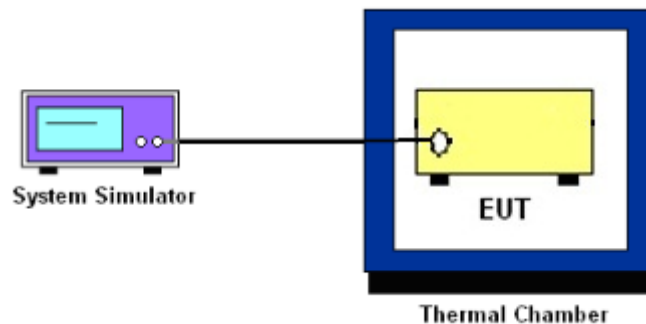

3.3 Test Result of Conducted Test

Please refer to Appendix A.



3.4 Conducted Output Power and EIRP

3.4.1 Description of the Conducted Output Power Measurement and EIRP Measurement

A system simulator was used to establish communication with the EUT. Its parameters were set to force the EUT transmitting at maximum output power. The measured power in the radio frequency on the transmitter output terminals shall be reported.

The EIRP of mobile transmitters must not exceed 2 Watts for LTE Band 41.

According to KDB 412172 D01 Power Approach,

$EIRP = P_T + G_T - L_C$, $ERP = EIRP - 2.15$, where

P_T = transmitter output power in dBm

G_T = gain of the transmitting antenna in dBi

L_C = signal attenuation in the connecting cable between the transmitter and antenna in dB

3.4.2 Test Procedures

1. The transmitter output port was connected to the system simulator.
2. Set EUT at maximum power through the system simulator.
3. Select lowest, middle, and highest channels for each band and different modulation.
4. Measure and record the power level from the system simulator.



3.5 Peak-to-Average Ratio

3.5.1 Description of the PAR Measurement

Power Complementary Cumulative Distribution Function (CCDF) curves provide a means for characterizing the power peaks of a digitally modulated signal on a statistical basis. A CCDF curve depicts the probability of the peak signal amplitude exceeding the average power level. Most contemporary measurement instrumentation include the capability to produce CCDF curves for an input signal provided that the instrument's resolution bandwidth can be set wide enough to accommodate the entire input signal bandwidth. In measuring transmissions in this band using an average power technique, the peak-to-average ratio (PAR) of the transmission may not exceed 13 dB.

3.5.2 Test Procedures

The testing follows FCC KDB 971168 v03 Section 5.7.1

1. The EUT was connected to spectrum and system simulator via a power divider.
2. Set the CCDF (Complementary Cumulative Distribution Function) option in spectrum analyzer.
3. The highest RF powers were measured and recorded the maximum PAPR level associated with a probability of 0.1 %.
4. Record the deviation as Peak to Average Ratio.



3.6 Occupied Bandwidth

3.6.1 Description of Occupied Bandwidth Measurement

The occupied bandwidth is the width of a frequency band such that, below the lower and above the upper frequency limits, the mean powers emitted are each equal to a specified percentage 0.5% of the total mean transmitted power.

The 26 dB emission bandwidth is defined as the frequency range between two points, one above and one below the carrier frequency, at which the spectral density of the emission is attenuated 26 dB below the maximum in-band spectral density of the modulated signal. Spectral density (power per unit bandwidth) is to be measured with a detector of resolution bandwidth equal to approximately 1.0% of the emission bandwidth.

3.6.2 Test Procedures

The testing follows FCC KDB 971168 v03 Section 4.2

1. The EUT was connected to spectrum analyzer and system simulator via a power divider.
2. The spectrum analyzer center frequency is set to the nominal EUT channel center frequency. The span range for the spectrum analyzer shall be between two and five times the anticipated OBW.
3. The nominal resolution bandwidth (RBW) shall be in the range of 1 to 5 % of the anticipated OBW, and the VBW shall be at least 3 times the RBW.
4. Set the detection mode to peak, and the trace mode to max hold.
5. Determine the reference value: Set the EUT to transmit a modulated signal. Allow the trace to stabilize. Set the spectrum analyzer marker to the highest level of the displayed trace.
(this is the reference value)
6. Determine the “-26 dB down amplitude” as equal to (Reference Value – X).
7. Place two markers, one at the lowest and the other at the highest frequency of the envelope of the spectral display such that each marker is at or slightly below the “-X dB down amplitude” determined in step 6. If a marker is below this “-X dB down amplitude” value it shall be placed as close as possible to this value. The OBW is the positive frequency difference between the two markers.
8. Use the 99 % power bandwidth function of the spectrum analyzer and report the measured bandwidth.



3.7 Conducted Band Edge

3.7.1 Description of Conducted Band Edge Measurement

27.53(m)(4)

For mobile digital stations, the attenuation factor shall be not less than $40 + 10 \log (P)$ dB on all frequencies between the channel edge and 5 megahertz from the channel edge, $43 + 10 \log (P)$ dB on all frequencies between 5 megahertz and X megahertz from the channel edge, and $55 + 10 \log (P)$ dB on all frequencies more than X megahertz from the channel edge, where X is the greater of 6 megahertz or the actual emission bandwidth as defined in paragraph (m)(6) of this section. In addition, the attenuation factor shall not be less than $43 + 10 \log (P)$ dB on all frequencies between 2490.5 MHz and 2496 MHz and $55 + 10 \log (P)$ dB at or below 2490.5 MHz. Mobile Satellite Service licensees operating on frequencies below 2495 MHz may also submit a documented interference complaint against BRS licensees operating on channel BRS Channel 1 on the same terms and conditions as adjacent channel BRS or EBS licensees.

3.7.2 Test Procedures

The testing follows FCC KDB 971168 v03 Section 6.0.

1. The EUT was connected to spectrum analyzer and system simulator via a power divider.
2. The band edges of low and high channels for the highest RF powers were measured.
3. Set RBW \geq 1% EBW in the 1MHz band immediately outside and adjacent to the band edge.
4. Beyond the 1 MHz band from the band edge, RBW=1MHz was used.
5. Set spectrum analyzer with RMS detector.
6. The RF fundamental frequency should be excluded against the limit line in the operating frequency band.
7. Checked that all the results comply with the emission limit line.
8. For LTE Band 41, the other 40 dB, and 55 dB have additionally applied same calculation above.



3.8 Conducted Spurious Emission

3.8.1 Description of Conducted Spurious Emission Measurement

For Band 41:

The power of any emission outside of the authorized operating frequency ranges must be lower than the transmitter power (P) by a factor of at least $55 + 10 \log (P)$ dB.

It is measured by means of a calibrated spectrum analyzer and scanned from 30 MHz up to a frequency including its 10th harmonic.

3.8.2 Test Procedures

The testing follows FCC KDB 971168 v03 Section 6.0.

1. The EUT was connected to spectrum analyzer and system simulator via a power divider.
2. The RF output of EUT was connected to the spectrum analyzer by RF cable and attenuator.
The path loss was compensated to the results for each measurement.
3. The middle channel for the highest RF power within the transmitting frequency was measured.
4. The conducted spurious emission for the whole frequency range was taken.
5. Make the measurement with the spectrum analyzer's RBW = 1MHz, VBW = 3MHz.
6. Set spectrum analyzer with RMS detector.
7. Taking the record of maximum spurious emission.
8. The RF fundamental frequency should be excluded against the limit line in the operating frequency band.
9. For Band 41

The limit line is derived from $55 + 10\log(P)$ dB below the transmitter power P(Watts)



3.9 Frequency Stability

3.9.1 Description of Frequency Stability Measurement

The frequency stability shall be measured by variation of ambient temperature and variation of primary supply voltage to ensure that the fundamental emission stays within the authorized frequency block. The frequency stability of the transmitter shall be maintained within $\pm 0.00025\%$ ($\pm 2.5\text{ppm}$) of the center frequency.

3.9.2 Test Procedures for Temperature Variation

The testing follows FCC KDB 971168 v03 Section 9.0.

1. The EUT was set up in the thermal chamber and connected with the system simulator.
2. With power OFF, the temperature was decreased to -30°C and the EUT was stabilized before testing. Power was applied and the maximum change in frequency was recorded within one minute.
3. With power OFF, the temperature was raised in 10°C step up to 50°C . The EUT was stabilized at each step for at least half an hour. Power was applied and the maximum frequency change was recorded within one minute.

3.9.3 Test Procedures for Voltage Variation

The testing follows FCC KDB 971168 v03 Section 9.0.

1. The EUT was placed in a temperature chamber at $20\pm 5^{\circ}\text{C}$ and connected with the system simulator.
2. The power supply voltage to the EUT was varied from 85% to 115% of the nominal value measured at the input to the EUT.
3. The variation in frequency was measured for the worst case.

4 Radiated Test Items

4.1 Measuring Instruments

See list of measuring instruments of this test report.

4.2 Test Setup

4.2.1 For radiated test from 30MHz to 1GHz

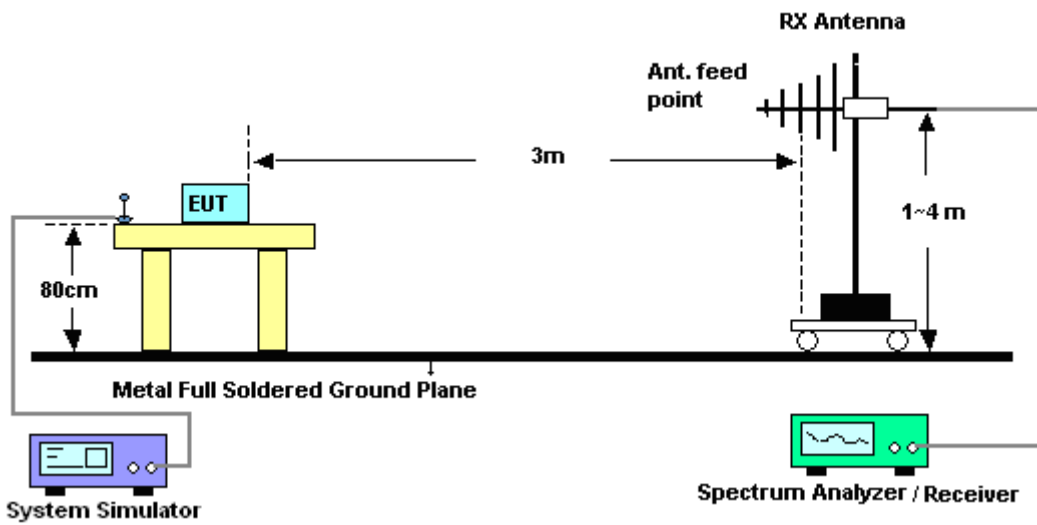

4.2.2 For radiated test above 1GHz

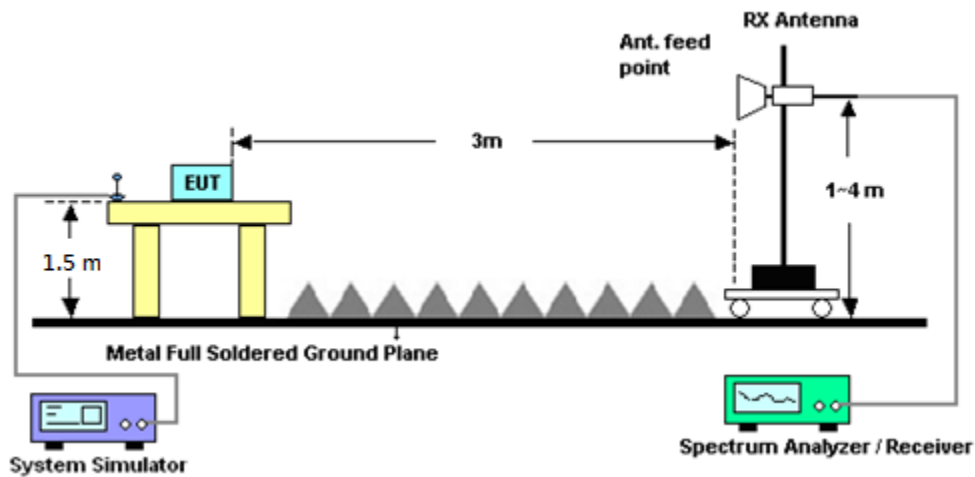

4.3 Test Result of Radiated Test

Please refer to Appendix B.



4.4 Radiated Spurious Emission

4.4.1 Description of Radiated Spurious Emission

The radiated spurious emission was measured by substitution method according to ANSI / TIA-603-E.

For Band 41

The power of any emission outside of the authorized operating frequency ranges must be attenuated below the transmitter power (P) by a factor of at least $55 + 10 \log (P)$ dB.

4.4.2 Test Procedures

The testing follows FCC KDB 971168 v03 Section 5.8 and ANSI / TIA-603-E Section 2.2.12.

1. The EUT was placed on a turntable with 0.8 meter for frequency below 1GHz and 1.5 meter for frequency above 1GHz respectively above ground.
2. The EUT was set 3 meters from the receiving antenna, which was mounted on the antenna tower.
3. The table was rotated 360 degrees to determine the position of the highest spurious emission.
4. The height of the receiving antenna is varied between one meter and four meters to search the maximum spurious emission for both horizontal and vertical polarizations.
5. Make the measurement with the spectrum analyzer's RBW = 1MHz, VBW = 3MHz, taking the record of maximum spurious emission.
6. A horn antenna was substituted in place of the EUT and was driven by a signal generator.
7. Tune the output power of signal generator to the same emission level with EUT maximum spurious emission.
8. Taking the record of output power at antenna port.
9. Repeat step 7 to step 8 for another polarization.
10. The RF fundamental frequency should be excluded against the limit line in the operating frequency band.
11. For Band 41:

The limit line is derived from $55 + 10\log(P)$ dB below the transmitter power P(Watts)

$EIRP \text{ (dBm)} = S.G. \text{ Power} - Tx \text{ Cable Loss} + Tx \text{ Antenna Gain}$

$ERP \text{ (dBm)} = EIRP - 2.15$



5 List of Measuring Equipment

Instrument	Manufacturer	Model No.	Serial No.	Characteristics	Calibration Date	Test Date	Due Date	Remark
Spectrum Analyzer	R&S	FSV30	101338	10kHz~30GHz; Max 30dBm	May 25, 2017	Mar. 07, 2018~ Mar. 08, 2018	May 24, 2018	Conducted (TH01-KS)
Temperature Chamber	Hongzhan	LP-150U	2306	Temperature (-40~150°C) Humidity (20~98%RH)	Apr. 20, 2017	Mar. 07, 2018~ Mar. 08, 2018	Apr. 19, 2018	Conducted (TH01-KS)
Radio communication analyzer	Anritsu	MT8820C	620143283 0	GSM / GPRS /WCDMA / LTE FDD/TDD with 44) /LTE-3	Jan. 18, 2018	Mar. 07, 2018~ Mar. 08, 2018	Jan. 17, 2019	Conducted (TH01-KS)
Amplifier	MITEQ	TTA1840-35- HG	1887435	18~40GHz,45d B Min	Oct. 12, 2017	Mar. 08, 2018	Oct. 11, 2018	Radiation (03CH03-KS)
Amplifier	com-power	MITEQ	2025788	100MHz ~1800MHz /	Apr. 18, 2018	Mar. 08, 2018	Apr. 17, 2019	Radiation (03CH03-KS)
Bilog Antenna	TeseQ	CBL6112D	35406	25MHz-2GHz	Apr. 22, 2017	Mar. 08, 2018	Apr. 21, 2018	Radiation (03CH03-KS)
Horn Antenna	Schwarzbeck	BBHA9120D	9120D-135 6	1GHz~18GHz	Apr. 22, 2017	Mar. 08, 2018	Apr. 21, 2018	Radiation (03CH03-KS)
Amplifier	com-power	PA-103A	161069	1MHz ~1000MHz / 32 dB	Apr. 18, 2017	Mar. 08, 2018	Apr. 17, 2018	Radiation (03CH03-KS)
Amplifier	Agilent	8449B	3008A023 70	1GHz~26.5GHz	Oct. 12, 2017	Mar. 08, 2018	Oct. 11, 2018	Radiation (03CH03-KS)
EXA Spectrum Analyzer	Keysight	N9010A	MY551502 44	10Hz-44GHz	Apr. 18, 2017	Mar. 08, 2018	Apr. 17, 2018	Radiation (03CH03-KS)
Controller	ChamPro	EM 1000	060762	N/A	N/A	Mar. 08, 2018	N/A	Radiation (03CH03-KS)
Turn Table	ChamPro	EM 1000-T	060762-T	0-360°	N/A	Mar. 08, 2018	N/A	Radiation (03CH03-KS)
Antenna Mast	ChamPro	EM 1000-A	060762-A	1m-4m	N/A	Mar. 08, 2018	N/A	Radiation (03CH03-KS)
SHF-EHF Horn	com-power	AH-840	101070	18Ghz-40Ghz	Dec. 06, 2017	Mar. 08, 2018	Dec. 05, 2018	Radiation (03CH03-KS)
Double Ridge horn Antenna	ETS-lindgren	3117	75957	1GHz~18GHz	Oct. 21, 2017	Mar. 08, 2018	Oct. 20, 2018	Radiation (03CH03-KS)
Signal Generator	R&S	SMR40	100455	10MHz~40GHz	Jan. 18, 2018	Mar. 08, 2018	Jan. 17, 2019	Radiation (03CH03-KS)



6 Uncertainty of Evaluation

Uncertainty of Radiated Emission Measurement (30 MHz ~ 1000 MHz)

Measuring Uncertainty for a Level of Confidence of 95% ($U = 2Uc(y)$)	2.81
---	------

Uncertainty of Radiated Emission Measurement (1 GHz ~ 40 GHz)

Measuring Uncertainty for a Level of Confidence of 95% ($U = 2Uc(y)$)	3.27
---	------



Appendix A. Test Results of Conducted Test

Conducted Output Power(Average power)

LTE Band 41 Maximum Average Power [dBm]						
BW [MHz]	RB Size	RB Offset	Mod	Lowest	Middle	Highest
20	1	0	QPSK	23.54	23.57	23.58
20	1	49		24.52	24.52	24.25
20	1	99		24.79	24.58	24.54
20	50	0		23.03	23.13	23.18
20	50	24		23.09	23.06	22.99
20	50	50		23.15	23.21	23.04
20	100	0		23.20	23.13	22.96
20	1	0	16-QAM	23.24	23.23	23.06
20	1	49		23.18	23.18	23.00
20	1	99		23.50	23.21	23.28
20	50	0		22.03	22.18	22.23
20	50	24		22.20	22.19	22.04
20	50	50		22.27	22.14	22.09
20	100	0		22.30	22.25	22.09
20	1	0	64-QAM	22.45	22.77	22.72
20	1	49		22.88	22.62	22.38
20	1	99		22.93	22.87	22.68
20	50	0		21.62	21.71	21.66
20	50	24		21.71	21.67	21.54
20	50	50		21.81	21.74	21.59
20	100	0		21.93	21.72	21.63
15	1	0	QPSK	23.96	24.01	23.85
15	1	37		24.92	24.76	24.40
15	1	74		24.93	24.56	24.60
15	36	0		23.02	23.07	23.12
15	36	20		22.97	23.13	23.03
15	36	39		23.15	23.18	23.06
15	75	0		22.97	23.06	23.06
15	1	0	16-QAM	23.29	23.45	23.28
15	1	37		23.22	23.15	22.94
15	1	74		23.90	23.71	23.30
15	36	0		21.98	22.01	22.01
15	36	20		22.03	22.10	21.99
15	36	39		22.03	22.05	21.88
15	75	0		22.19	22.23	21.94
15	1	0	64-QAM	22.95	22.97	22.81
15	1	37		22.83	22.73	22.11
15	1	74		22.94	22.94	22.85
15	36	0		21.43	21.63	21.58
15	36	20		21.46	21.62	21.40
15	36	39		21.71	21.76	21.49
15	75	0		21.49	21.76	21.50



LTE Band 41 Maximum Average Power [dBm]						
BW [MHz]	RB Size	RB Offset	Mod	Lowest	Middle	Highest
10	1	0	QPSK	23.83	23.80	23.62
10	1	25		24.70	24.55	24.48
10	1	49		24.72	24.96	24.88
10	25	0		22.97	23.10	22.84
10	25	12		22.95	23.01	22.81
10	25	25		23.04	22.99	23.01
10	50	0		23.02	23.02	22.83
10	1	0	16-QAM	23.27	23.31	23.29
10	1	25		23.21	23.16	23.22
10	1	49		23.56	23.39	23.29
10	25	0		22.08	22.01	21.83
10	25	12		22.03	22.01	21.88
10	25	25		22.07	22.16	22.17
10	50	0		21.97	22.04	22.07
10	1	0	64-QAM	22.76	22.63	22.56
10	1	25		22.63	22.51	22.29
10	1	49		22.86	22.87	22.67
10	25	0		21.49	21.52	21.54
10	25	12		21.50	21.46	21.42
10	25	25		21.56	21.57	21.51
10	50	0		21.49	21.49	21.33
5	1	0	QPSK	23.69	23.83	23.84
5	1	12		24.35	24.56	24.09
5	1	24		24.71	24.60	24.53
5	12	0		23.09	23.09	23.01
5	12	7		23.14	23.08	22.94
5	12	13		23.12	23.07	22.83
5	25	0		22.93	22.91	22.96
5	1	0	16-QAM	23.27	23.35	23.08
5	1	12		23.00	23.05	23.26
5	1	24		23.24	23.23	23.10
5	12	0		21.95	22.01	21.87
5	12	7		22.09	22.11	22.13
5	12	13		22.15	22.01	22.01
5	25	0		22.00	22.09	22.16
5	1	0	64-QAM	22.74	22.80	22.48
5	1	12		22.67	22.59	22.63
5	1	24		22.65	22.60	22.54
5	12	0		21.54	21.63	21.49
5	12	7		21.52	21.53	21.45
5	12	13		21.39	21.42	21.61
5	25	0		21.56	21.44	21.31



LTE Band 41_CA Maximum Average Power [dBm]									
BW [MHz]	PCC		SCC		Mod	Lowest	Middle	Highest	
	RB Size	RB Offset	RB Size	RB Offset					
20+20	0	0	1	99	QPSK	23.20	23.43	23.40	
20+20	1	0	0	0		23.29	23.84	23.81	
20+20	100	0	0	0		20.12	22.06	22.05	
20+20	100	0	100	0		22.64	21.68	21.73	
20+20	1	0	1	99		14.88	14.57	14.53	
20+20	1	0	1	0		20.10	19.46	19.40	
20+20	1	99	1	0		23.27	23.35	23.34	
20+20	100	0	1	99		19.97	19.21	20.18	
20+20	0	0	1	99		22.17	22.45	22.35	
20+20	1	0	0	0	16-QAM	22.35	22.79	22.78	
20+20	100	0	0	0		21.14	21.22	21.09	
20+20	100	0	100	0		21.37	20.59	20.55	
20+20	1	0	1	99		14.49	14.64	14.58	
20+20	1	0	1	0		19.62	19.04	19.06	
20+20	1	99	1	0		23.13	22.31	22.16	
20+20	100	0	1	99		19.95	20.23	20.11	
20+20	0	0	1	99		64-QAM	22.34	22.23	22.26
20+20	1	0	0	0			22.25	22.27	22.31
20+20	100	0	0	0	21.52		21.49	21.49	
20+20	100	0	100	0	21.30		21.31	21.28	
20+20	1	0	1	99	14.86		14.89	14.81	
20+20	1	0	1	0	20.03		19.96	20.00	
20+20	1	99	1	0	20.00		19.85	20.00	
20+20	100	0	1	99	19.88		19.84	19.75	
20+15	100	0	75	0	QPSK		22.71	22.94	20.62
20+15	1	0	1	74		14.87	14.48	13.75	
20+15	1	99	1	0		23.13	22.21	21.03	
20+15	100	0	75	0	16-QAM	21.60	21.66	19.81	
20+15	1	0	1	74		15.03	14.45	14.06	
20+15	1	99	1	0		22.91	22.13	21.56	
20+15	100	0	75	0	64-QAM	21.48	21.63	21.82	
20+15	1	0	1	74		14.81	15.08	14.90	
20+15	1	99	1	0		20.08	20.34	20.16	
15+20	75	0	100	0	QPSK	22.62	22.82	20.60	
15+20	1	0	1	99		14.78	14.43	13.70	
15+20	1	74	1	0		23.07	22.20	21.01	
15+20	75	0	100	0	16-QAM	21.59	21.61	19.80	
15+20	1	0	1	99		14.98	14.42	13.98	
15+20	1	74	1	0		22.91	22.03	21.51	
15+20	75	0	100	0	64-QAM	21.73	21.77	21.68	
15+20	1	0	1	99		15.04	14.91	14.99	
15+20	1	74	1	0		20.16	20.27	20.20	



LTE Band 41_CA Maximum Average Power [dBm]								
BW [MHz]	PCC		SCC		Mod	Lowest	Middle	Highest
	RB Size	RB Offset	RB Size	RB Offset				
20+10	100	0	50	0	QPSK	22.66	22.91	20.55
20+10	1	0	1	49		14.77	14.42	13.64
20+10	1	99	1	0		23.08	22.19	20.98
20+10	100	0	50	0	16-QAM	21.50	21.75	19.77
20+10	1	0	1	49		15.03	14.47	14.03
20+10	1	99	1	0		23.00	22.05	21.57
20+10	100	0	50	0	64-QAM	21.80	21.73	21.61
20+10	1	0	1	49		14.95	15.07	15.11
20+10	1	99	1	0		20.28	20.31	20.26
10+20	50	0	100	0	QPSK	22.63	22.86	20.59
10+20	1	0	1	99		14.76	14.43	13.68
10+20	1	49	1	0		23.00	22.10	20.95
10+20	50	0	100	0	16-QAM	21.53	21.66	19.84
10+20	1	0	1	99		15.03	14.45	13.99
10+20	1	49	1	0		22.91	22.09	21.59
10+20	50	0	100	0	64-QAM	21.71	21.78	21.67
10+20	1	0	1	99		15.12	14.97	15.08
10+20	1	49	1	0		20.15	20.22	20.19
20+5	100	0	25	0	QPSK	22.71	22.86	20.68
20+5	1	0	1	24		14.81	14.44	13.66
20+5	1	99	1	0		23.00	22.13	20.98
20+5	100	0	25	0	16-QAM	21.56	21.66	19.82
20+5	1	0	1	24		14.99	14.44	14.07
20+5	1	99	1	0		22.85	22.12	21.62
20+5	100	0	25	0	64-QAM	21.86	21.75	21.76
20+5	1	0	1	24		15.02	15.14	14.98
20+5	1	99	1	0		20.34	20.30	20.15
5+20	25	0	100	0	QPSK	22.70	22.85	20.57
5+20	1	0	1	99		14.77	14.41	13.77
5+20	1	24	1	0		22.97	22.20	21.01
5+20	25	0	100	0	16-QAM	21.59	21.64	19.80
5+20	1	0	1	99		15.05	14.44	14.00
5+20	1	24	1	0		22.96	22.03	21.54
5+20	25	0	100	0	64-QAM	21.69	21.62	21.58
5+20	1	0	1	99		15.02	14.96	14.96
5+20	1	24	1	0		20.18	20.12	20.18
15+15	75	0	75	0	QPSK	22.60	22.86	20.62
15+15	1	0	1	74		14.77	14.50	13.69
15+15	1	74	1	0		23.01	22.08	20.96
15+15	75	0	75	0	16-QAM	21.63	21.61	19.81
15+15	1	0	1	74		15.07	14.49	14.03
15+15	1	74	1	0		22.92	22.10	21.56
15+15	75	0	75	0	64-QAM	21.74	21.75	21.62
15+15	1	0	1	74		15.03	14.91	15.06
15+15	1	74	1	0		20.22	20.23	20.14



LTE Band 41

Peak-to-Average Ratio

Mode	LTE Band 41 / 20MHz				
Mod.	QPSK		16QAM		Limit: 13dB
RB Size	1RB	Full RB	1RB	Full RB	Result
Lowest CH	5.1	5.91	5.07	5.77	PASS
Middle CH	5.48	4.93	6.06	6.2	
Highest CH	6.52	5.19	6.49	6.49	
Mod.	64QAM		Limit: 13dB		
RB Size	1RB	Full RB	Result		
Lowest CH	6.75	6.23	PASS		
Middle CH	5.59	6.14			
Highest CH	6.7	6.14			



LTE Band 41 / 20MHz / QPSK

Lowest Channel / 1RB

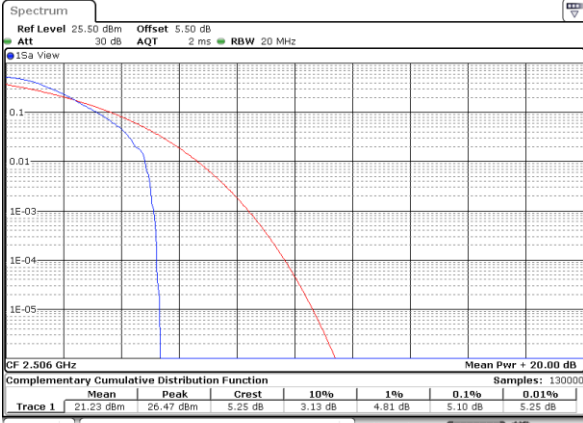

Date: 8 MAR 2019 04:37:21

Lowest Channel / Full RB

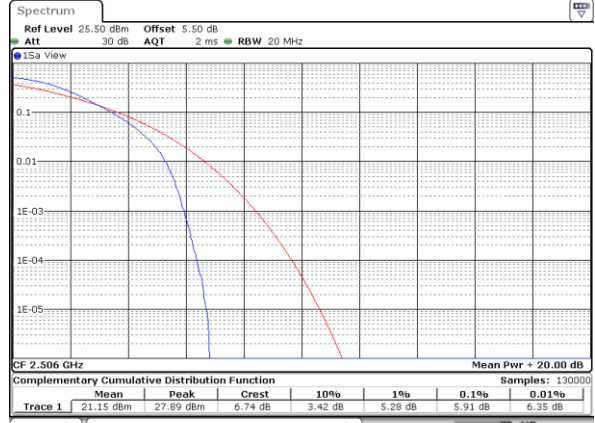

Date: 8 MAR 2019 04:35:09

Middle Channel / 1RB

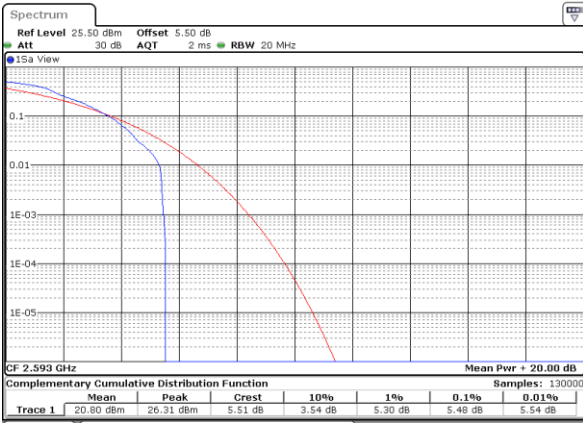

Date: 8 MAR 2019 04:38:08

Middle Channel / Full RB

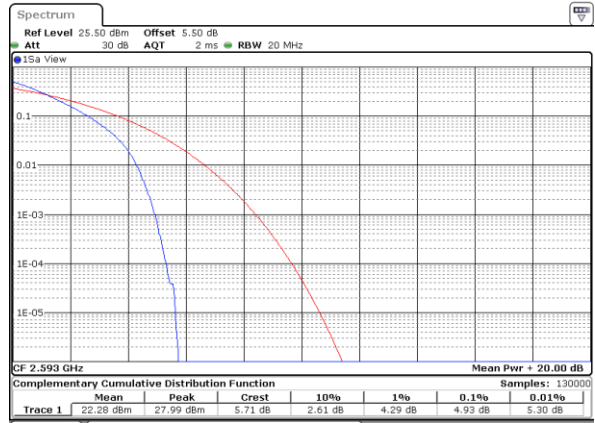

Date: 8 MAR 2019 04:40:06

Highest Channel / 1RB

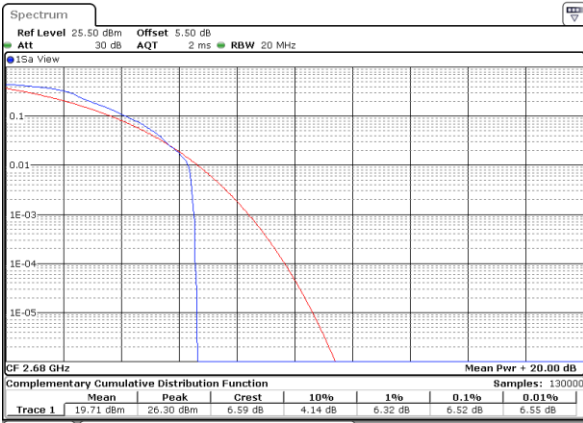

Date: 8 MAR 2019 04:42:25

Highest Channel / Full RB

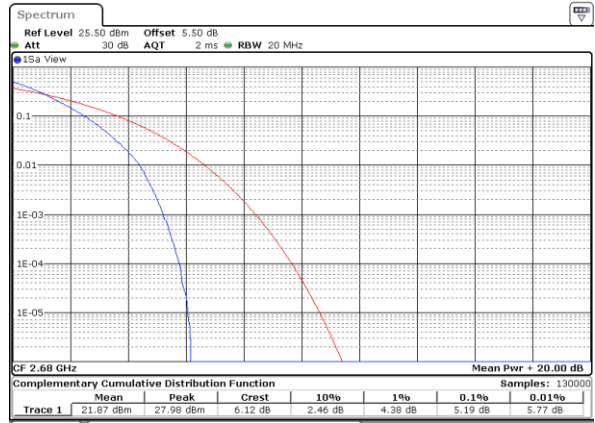

Date: 8 MAR 2019 04:44:35



LTE Band 41 / 20MHz / 16QAM

Lowest Channel / 1RB

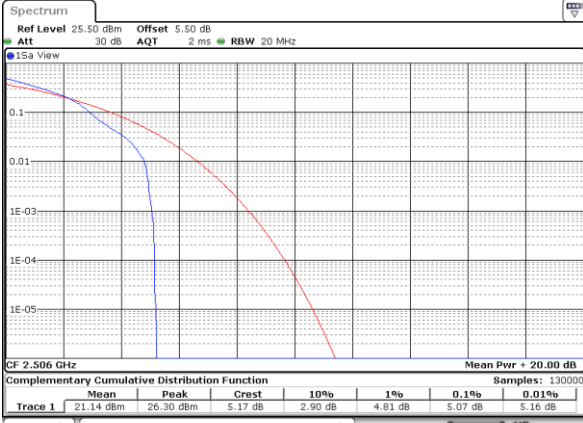

Date: 8 MAR 2019 04:37:03

Lowest Channel / Full RB

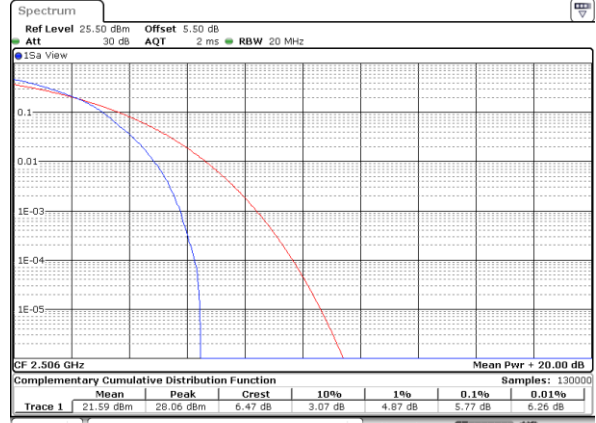

Date: 8 MAR 2019 04:35:51

Middle Channel / 1RB

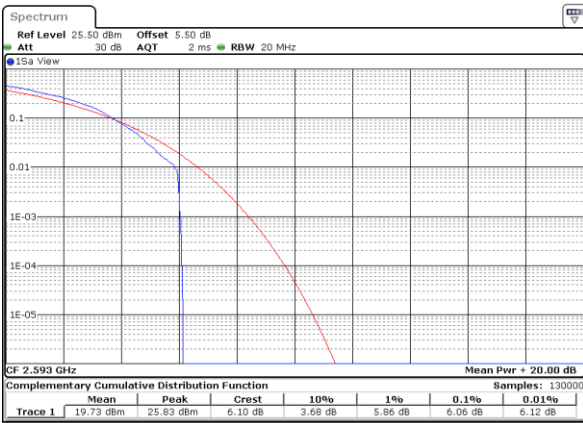

Date: 8 MAR 2019 04:41:06

Middle Channel / Full RB

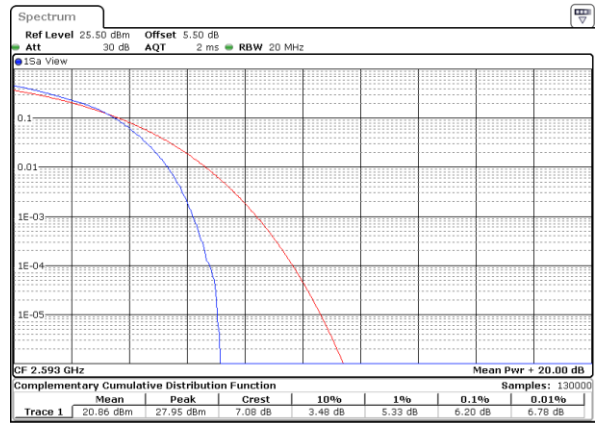

Date: 8 MAR 2019 04:39:47

Highest Channel / 1RB



Date: 8 MAR 2019 04:42:57

Highest Channel / Full RB



Date: 8 MAR 2019 04:44:06



LTE Band 41 / 20MHz / 64QAM

Lowest Channel / 1RB

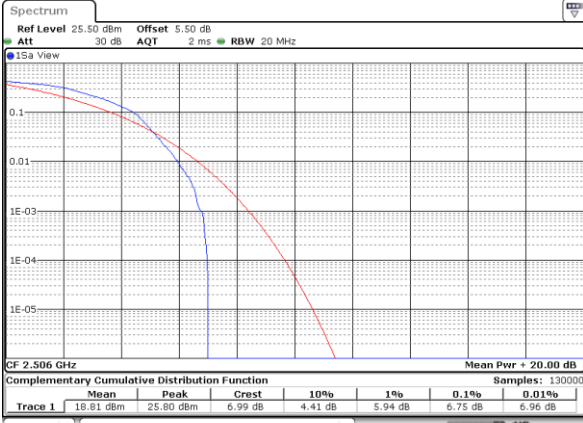

Date: 8 MAR 2019 04:36:31

Lowest Channel / Full RB

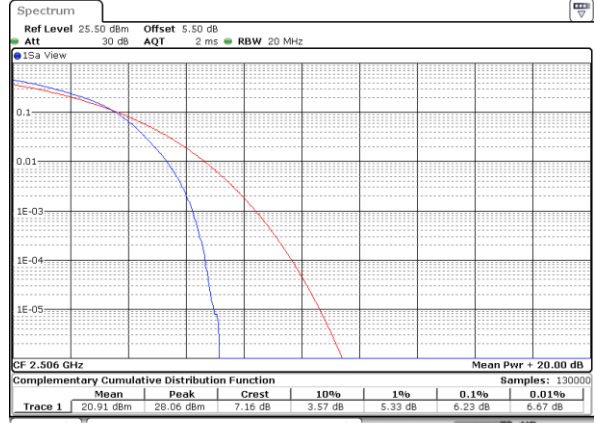

Date: 8 MAR 2019 04:36:07

Middle Channel / 1RB

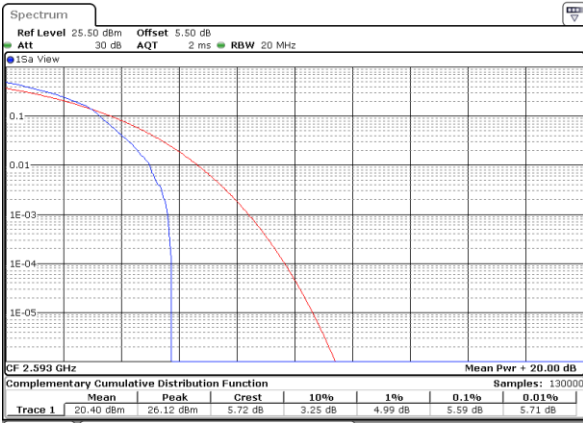

Date: 8 MAR 2019 04:38:59

Middle Channel / Full RB

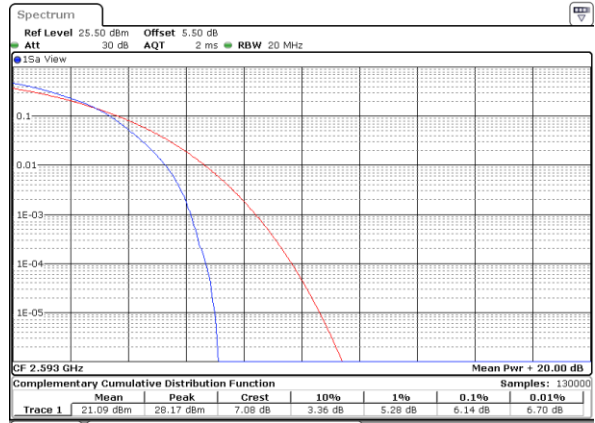

Date: 8 MAR 2019 04:39:30

Highest Channel / 1RB

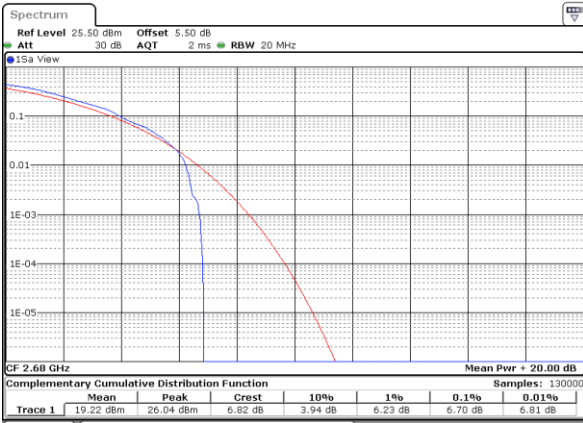

Date: 8 MAR 2019 04:43:26

Highest Channel / Full RB

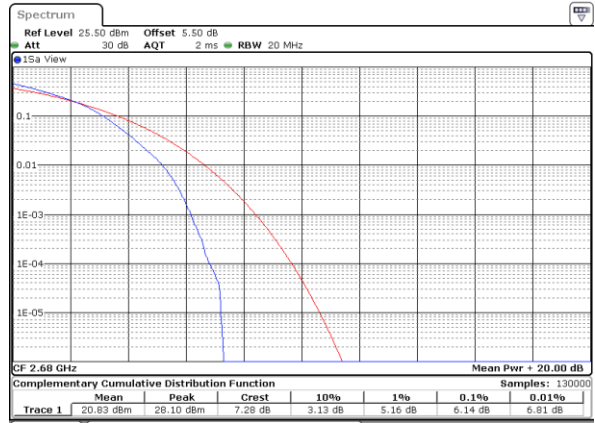

Date: 8 MAR 2019 04:43:47



26dB Bandwidth

Mode	LTE Band 41 : 26dB BW(MHz)											
BW	1.4MHz		3MHz		5MHz		10MHz		15MHz		20MHz	
Mod.	QPSK	16QAM	QPSK	16QAM	QPSK	16QAM	QPSK	16QAM	QPSK	16QAM	QPSK	16QAM
Lowest CH	-	-	-	-	4.865	4.845	9.65	9.67	14.146	14.176	20.1	20.14
Middle CH	-	-	-	-	4.875	4.805	9.75	9.61	14.416	14.116	20.22	20.18
Highest CH	-	-	-	-	4.945	4.905	9.65	9.69	14.505	14.386	20.06	20.1
Mode	LTE Band 41 : 26dB BW(MHz)											
BW					5MHz		10MHz		15MHz		20MHz	
Mod.					64QAM		64QAM		64QAM		64QAM	
Lowest CH	-	-	-	-	4.875		9.63		14.296		20.5	
Middle CH	-	-	-	-	4.845		9.65		14.176		20.22	
Highest CH	-	-	-	-	4.875		9.75		14.086		20.06	



LTE Band 41

Lowest Channel / 5MHz / QPSK

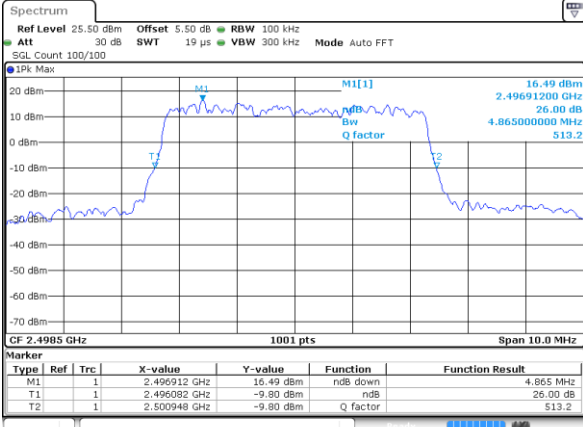

Date: 7 MAR 2019 23:48:26

Lowest Channel / 5MHz / 16QAM

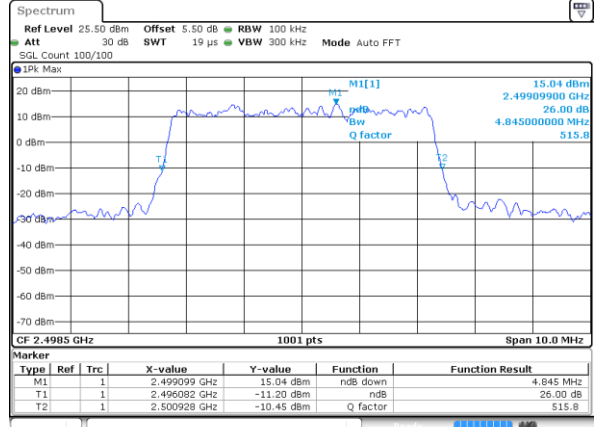

Date: 7 MAR 2019 23:48:51

Middle Channel / 5MHz / QPSK

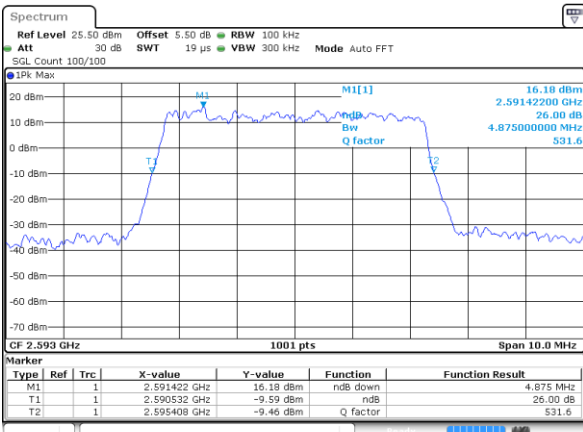

Date: 7 MAR 2019 23:52:33

Middle Channel / 5MHz / 16QAM

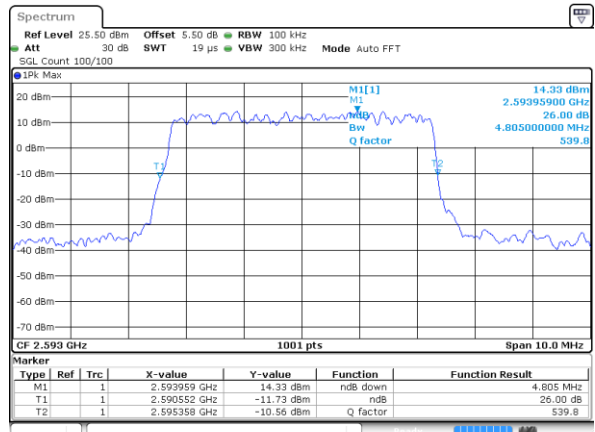

Date: 7 MAR 2019 23:52:09

Highest Channel / 5MHz / QPSK

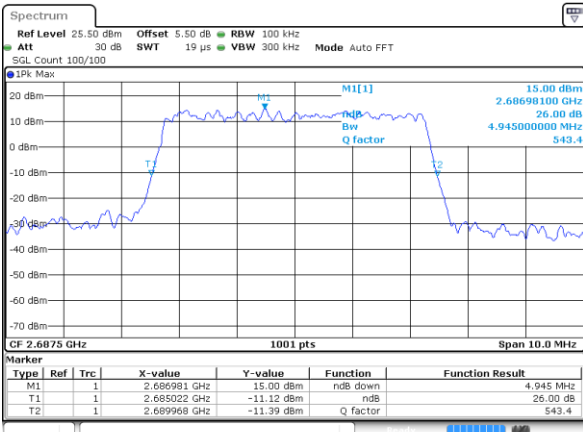

Date: 7 MAR 2019 23:52:58

Highest Channel / 5MHz / 16QAM

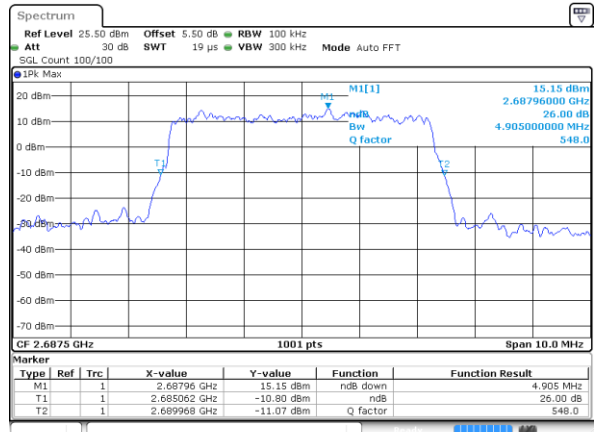

Date: 7 MAR 2019 23:53:17



LTE Band 41

Lowest Channel / 10MHz / QPSK

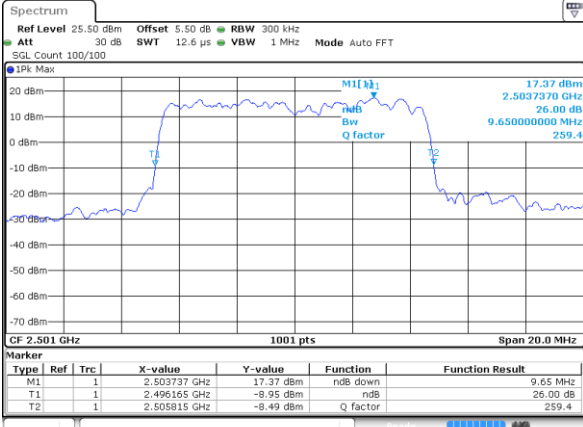

Date: 8 MAR 2019 00:52:26

Lowest Channel / 10MHz / 16QAM

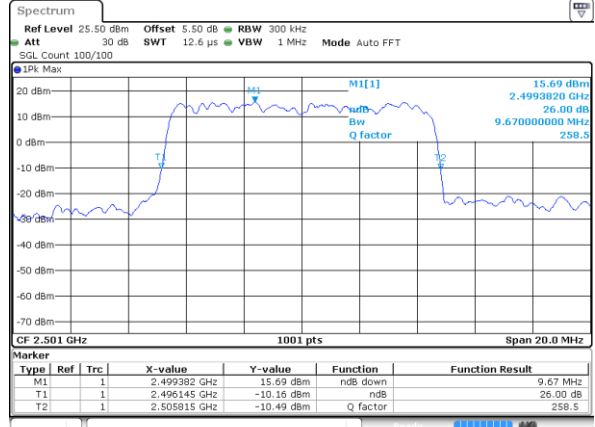

Date: 8 MAR 2019 00:52:45

Middle Channel / 10MHz / QPSK

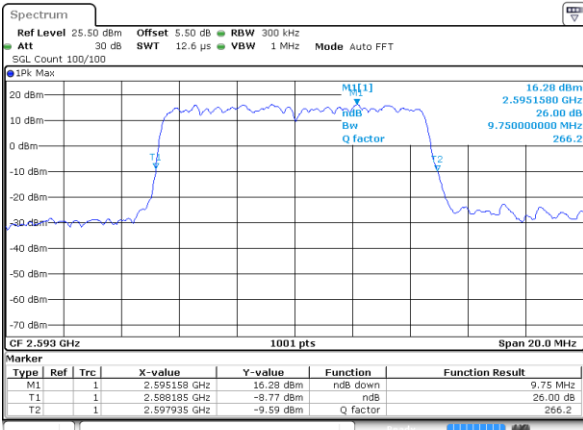

Date: 8 MAR 2019 00:54:27

Middle Channel / 10MHz / 16QAM

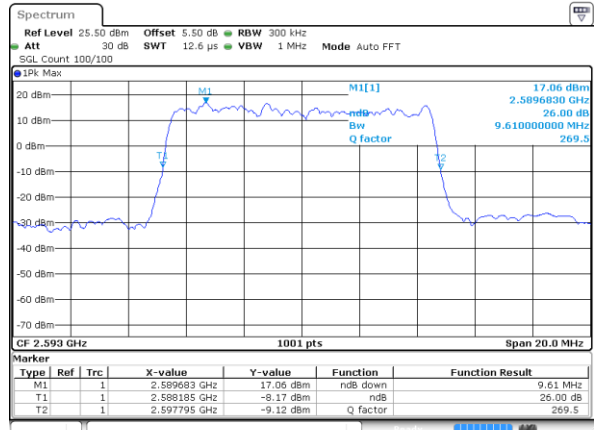

Date: 8 MAR 2019 00:53:53

Highest Channel / 10MHz / QPSK

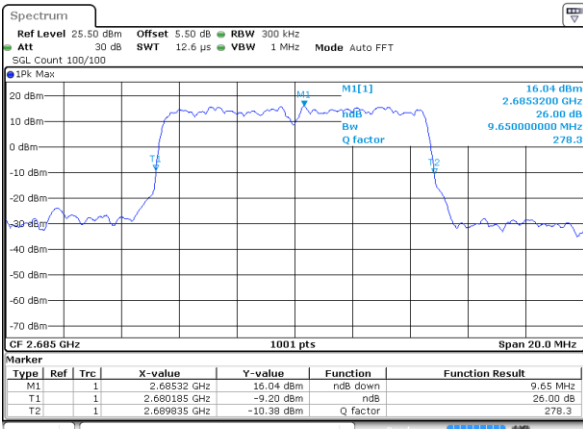

Date: 8 MAR 2019 00:55:14

Highest Channel / 10MHz / 16QAM

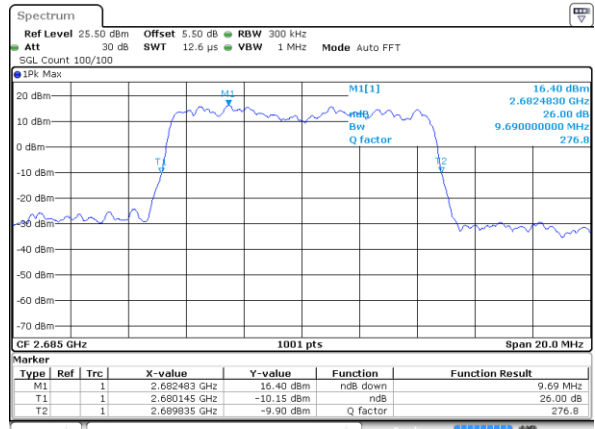

Date: 8 MAR 2019 00:55:33



LTE Band 41

Lowest Channel / 15MHz / QPSK

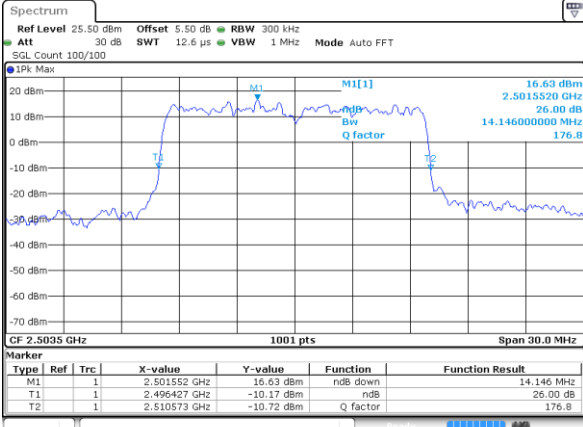

Date: 8 MAR 2019 02:40:11

Lowest Channel / 15MHz / 16QAM

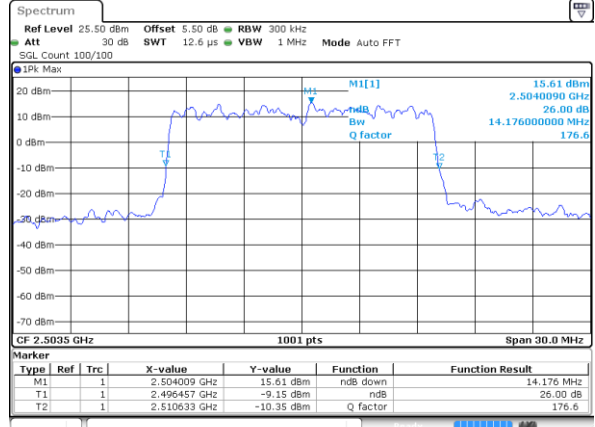

Date: 8 MAR 2019 02:40:32

Middle Channel / 15MHz / QPSK

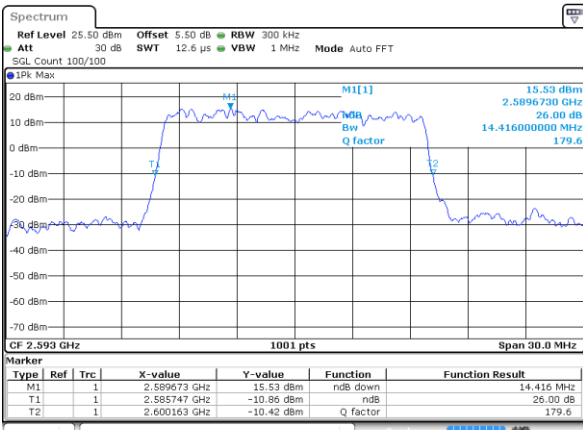

Date: 8 MAR 2019 02:43:48

Middle Channel / 15MHz / 16QAM

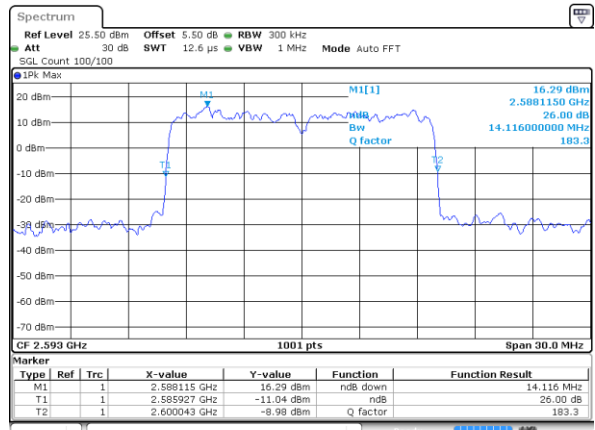

Date: 8 MAR 2019 02:43:16

Highest Channel / 15MHz / QPSK

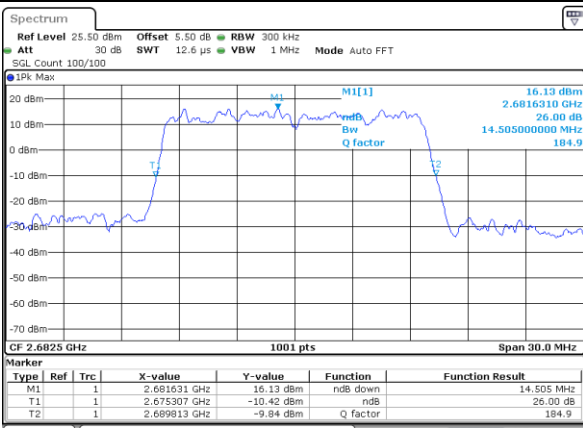

Date: 8 MAR 2019 02:45:27

Highest Channel / 15MHz / 16QAM

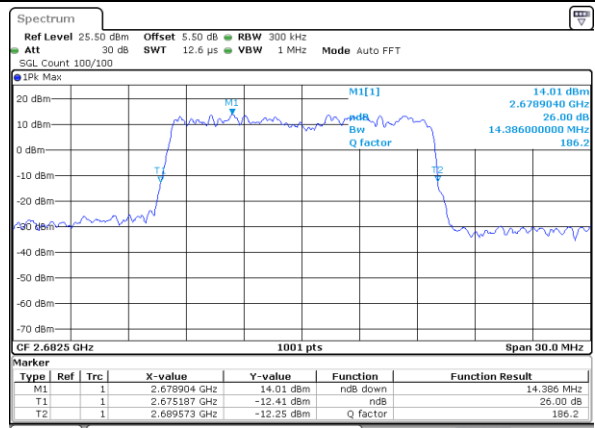

Date: 8 MAR 2019 02:46:11



LTE Band 41

Lowest Channel / 20MHz / QPSK

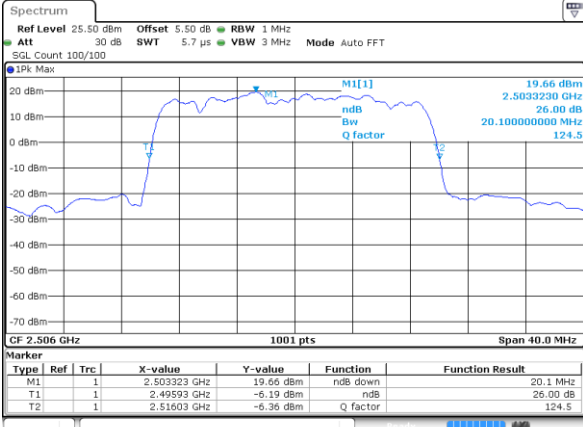

Date: 8 MAR 2019 04:27:55

Lowest Channel / 20MHz / 16QAM

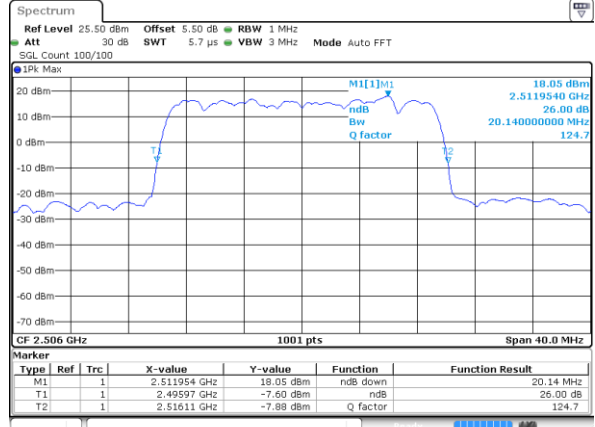

Date: 8 MAR 2019 04:28:17

Middle Channel / 20MHz / QPSK

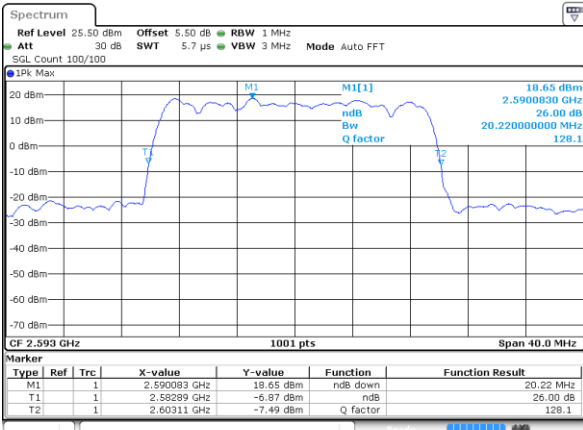

Date: 8 MAR 2019 04:29:55

Middle Channel / 20MHz / 16QAM

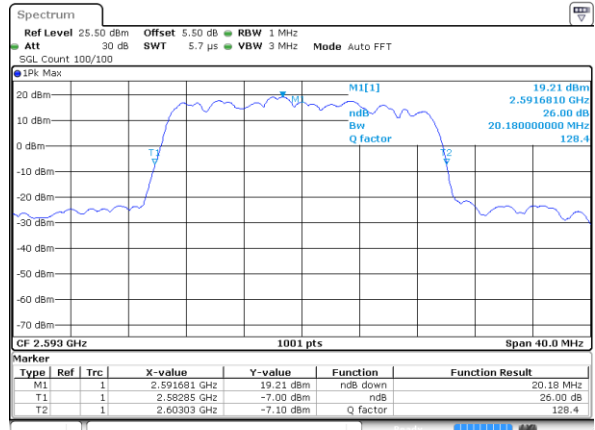

Date: 8 MAR 2019 04:28:34

Highest Channel / 20MHz / QPSK

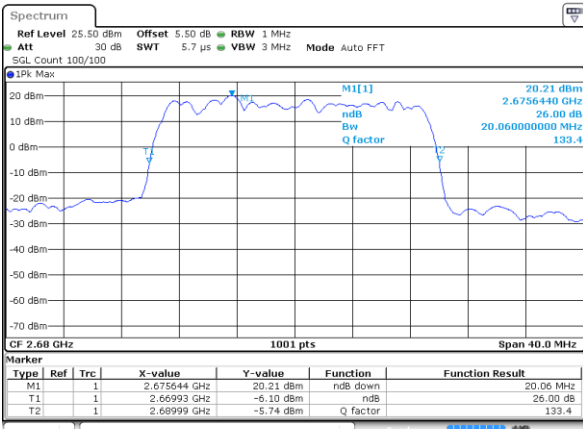

Date: 8 MAR 2019 04:30:38

Highest Channel / 20MHz / 16QAM

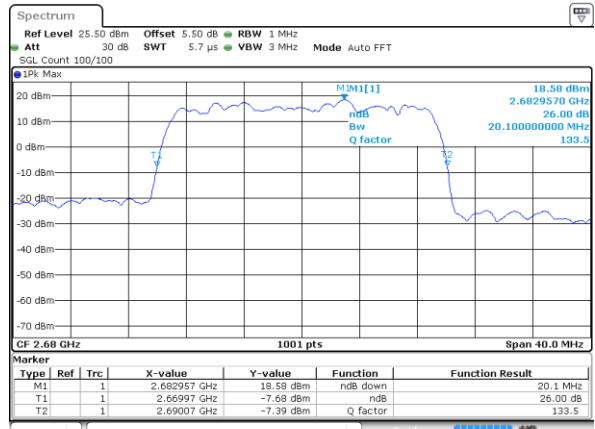

Date: 8 MAR 2019 04:31:27



LTE Band 41

Lowest Channel / 5MHz / 64QAM

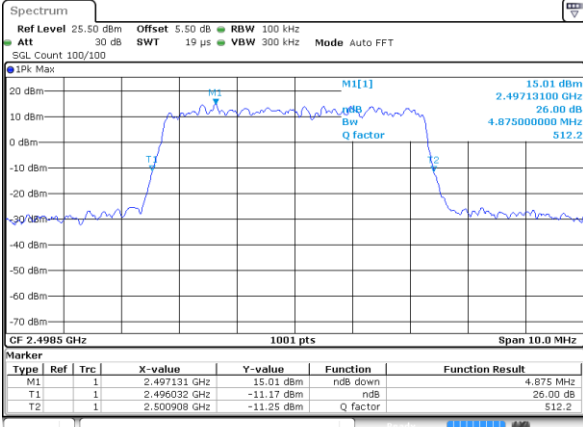

Date: 7 MAR 2019 23:50:38

Lowest Channel / 10MHz / 64QAM

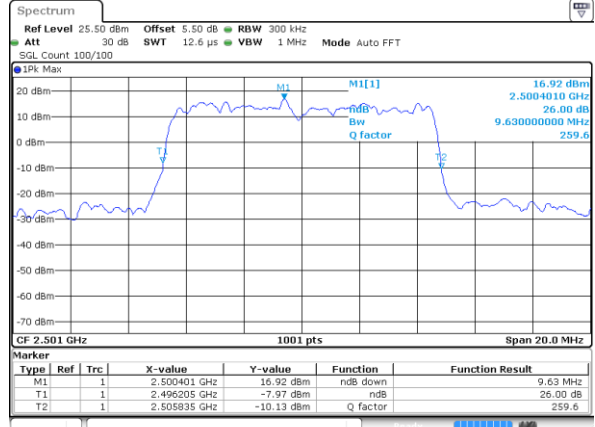

Date: 8 MAR 2019 00:53:09

Middle Channel / 5MHz / 64QAM

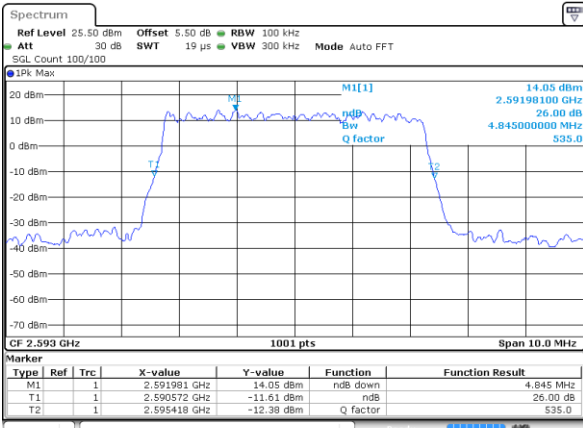

Date: 7 MAR 2019 23:51:50

Middle Channel / 10MHz / 64QAM

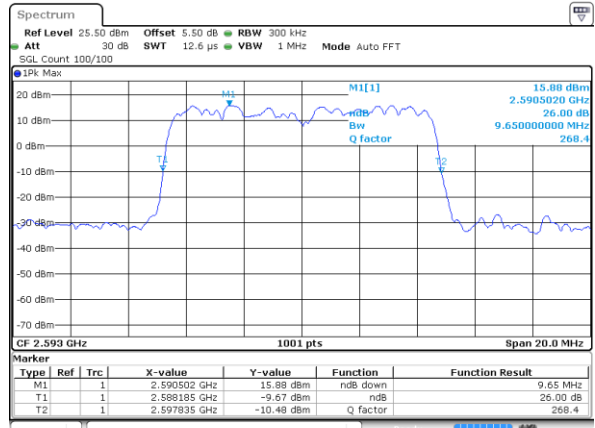

Date: 8 MAR 2019 00:53:32

Highest Channel / 5MHz / 64QAM

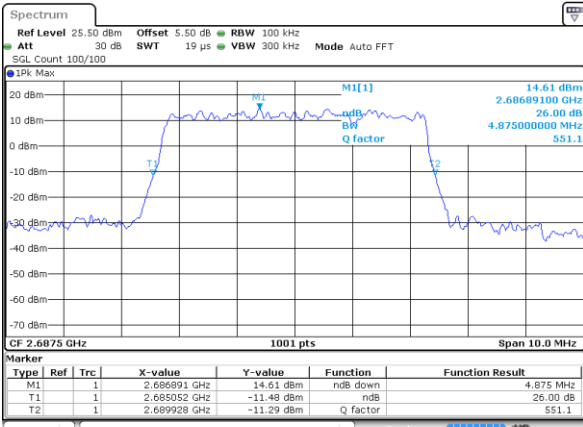

Date: 7 MAR 2019 23:53:35

Highest Channel / 10MHz / 64QAM

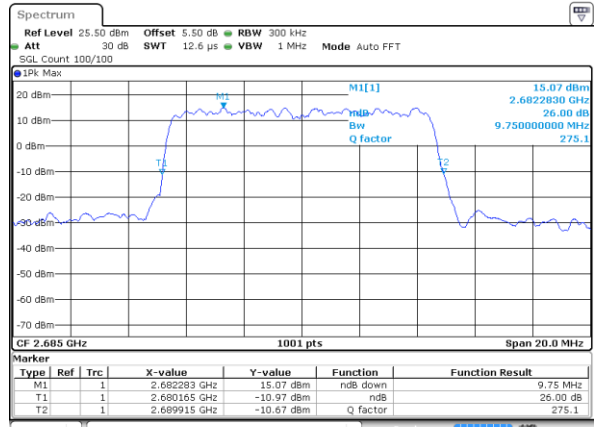

Date: 8 MAR 2019 00:56:01



LTE Band 41

Lowest Channel / 15MHz / 64QAM

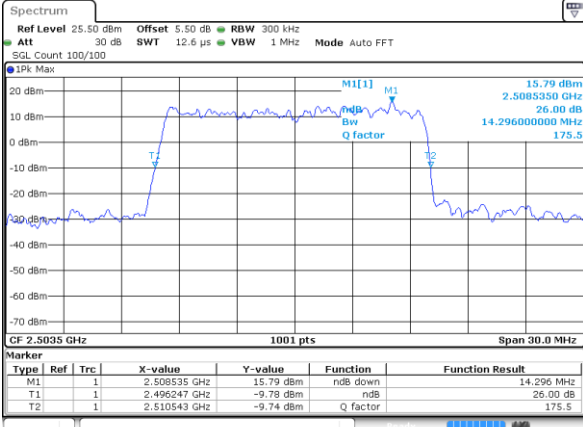

Date: 8 MAR 2019 02:41:42

Lowest Channel / 20MHz / 64QAM

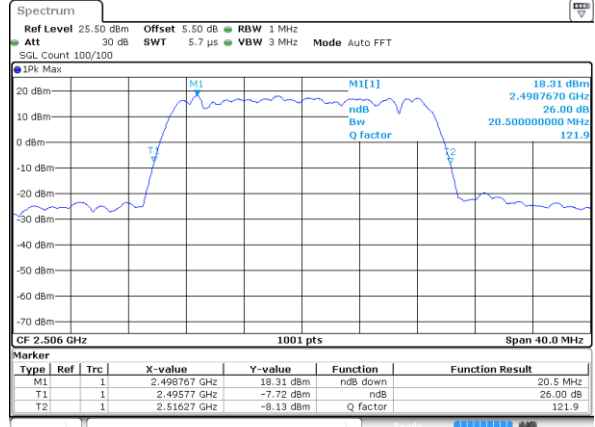

Date: 8 MAR 2019 04:28:38

Middle Channel / 15MHz / 64QAM

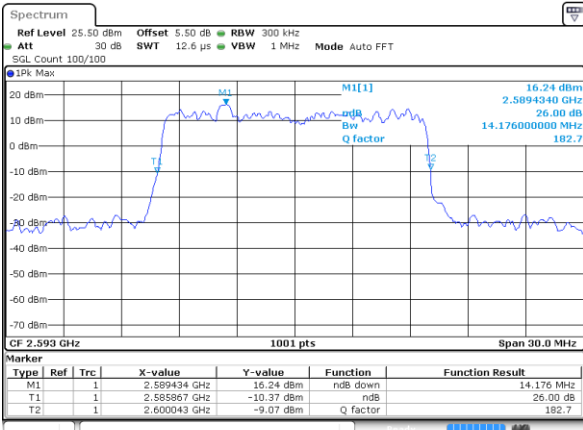

Date: 8 MAR 2019 02:42:54

Middle Channel / 20MHz / 64QAM

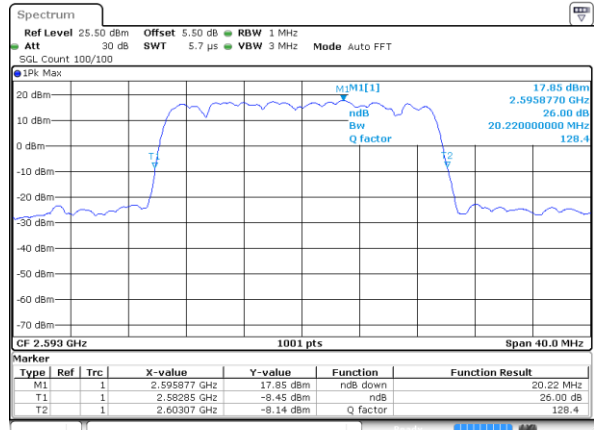

Date: 8 MAR 2019 04:28:10

Highest Channel / 15MHz / 64QAM

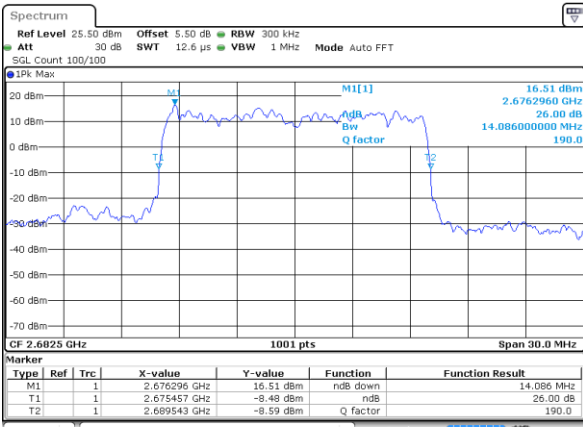

Date: 8 MAR 2019 02:46:32

Highest Channel / 20MHz / 64QAM

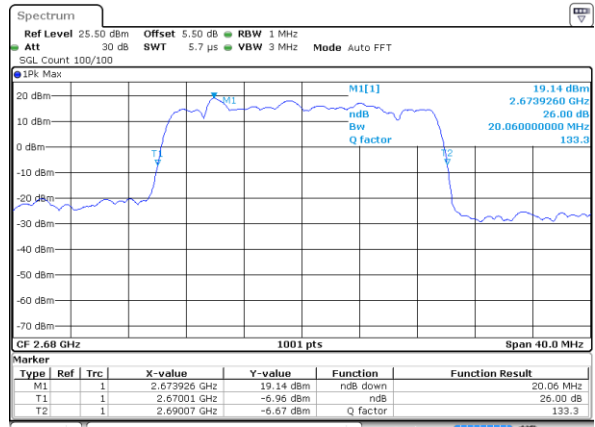

Date: 8 MAR 2019 04:31:50



Occupied Bandwidth

Mode	LTE Band 41 : 99%OBW(MHz)											
BW	1.4MHz		3MHz		5MHz		10MHz		15MHz		20MHz	
Mod.	QPSK	16QAM	QPSK	16QAM	QPSK	16QAM	QPSK	16QAM	QPSK	16QAM	QPSK	16QAM
Lowest CH	-	-	-	-	4.48	4.44	9.01	9.03	13.49	13.43	18.26	18.34
Middle CH	-	-	-	-	4.47	4.5	9.03	9.05	13.46	13.52	18.34	18.18
Highest CH	-	-	-	-	4.49	4.48	9.01	9.03	13.34	13.46	18.5	18.18
Mode	LTE Band 41 : 99%OBW(MHz)											
BW					5MHz		10MHz		15MHz		20MHz	
Mod.					64QAM		64QAM		64QAM		64QAM	
Lowest CH					4.49		9.05		13.49		18.42	
Middle CH	-	-	-	-	4.5		9.05		13.47		18.38	
Highest CH	-	-	-	-	4.47		9.05		13.43		18.38	



LTE Band 41

Lowest Channel / 5MHz / QPSK

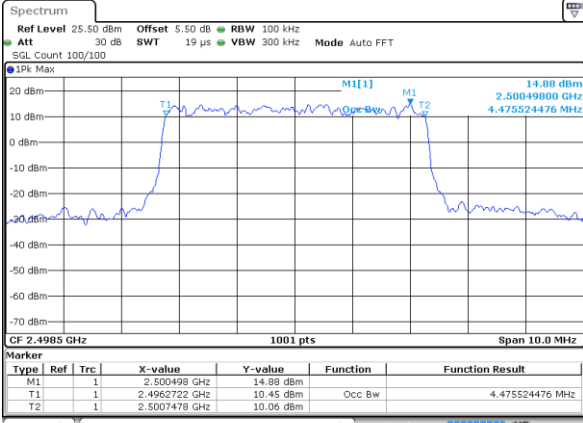

Date: 7 MAR 2019 23:48:16

Lowest Channel / 5MHz / 16QAM

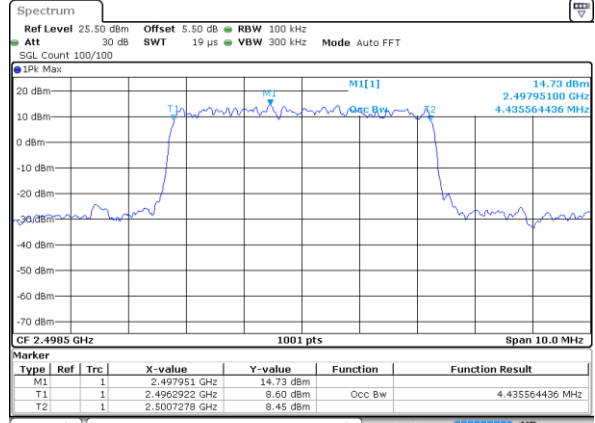

Date: 7 MAR 2019 23:48:40

Middle Channel / 5MHz / QPSK

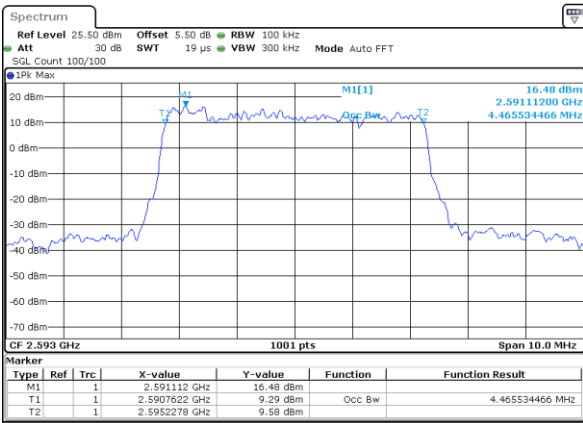

Date: 7 MAR 2019 23:52:21

Middle Channel / 5MHz / 16QAM

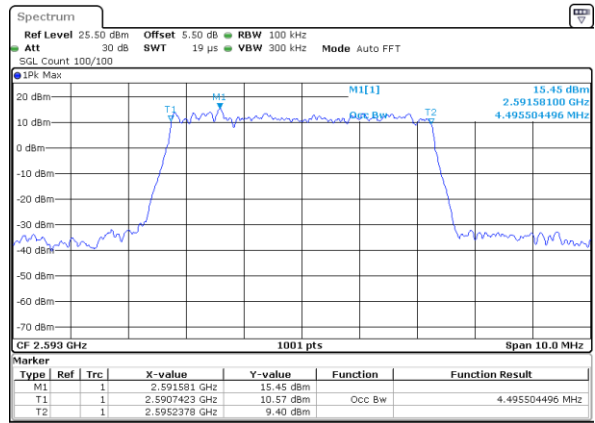

Date: 7 MAR 2019 23:52:01

Highest Channel / 5MHz / QPSK

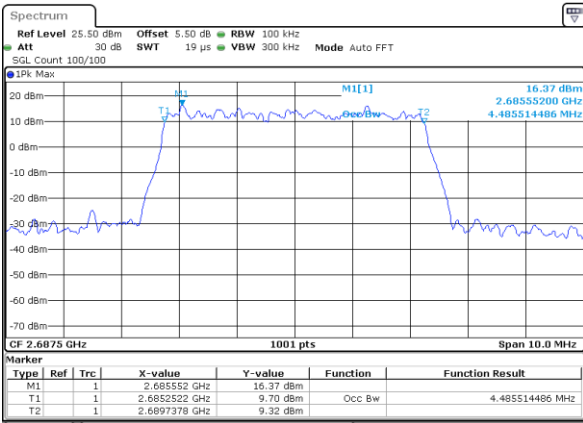

Date: 7 MAR 2019 23:52:47

Highest Channel / 5MHz / 16QAM

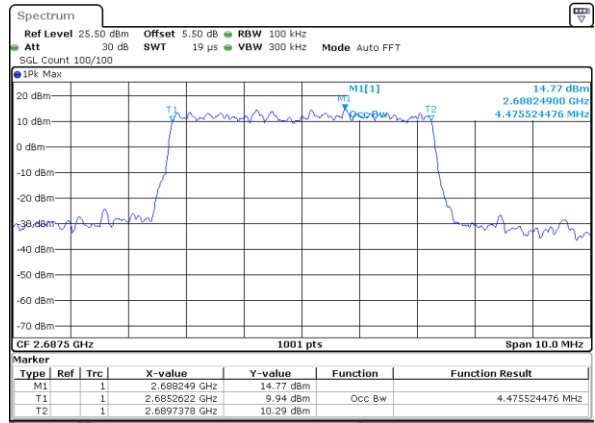

Date: 7 MAR 2019 23:53:08



LTE Band 41

Lowest Channel / 10MHz / QPSK

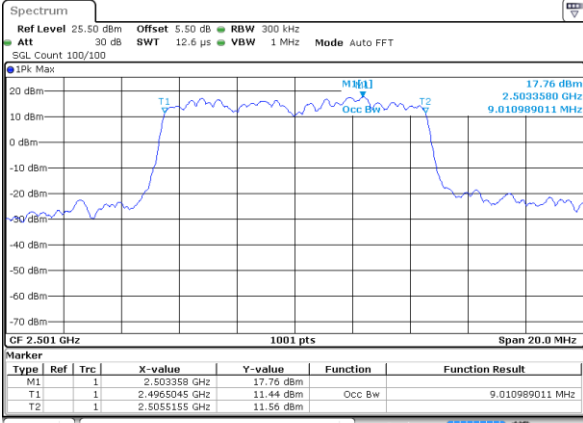

Date: 8 MAR 2019 00:52:17

Lowest Channel / 10MHz / 16QAM

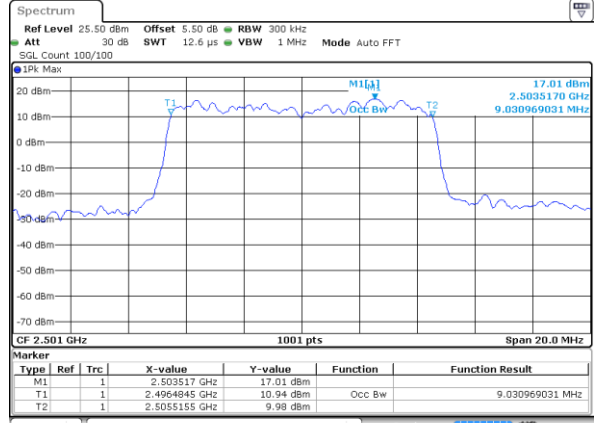

Date: 8 MAR 2019 00:52:36

Middle Channel / 10MHz / QPSK

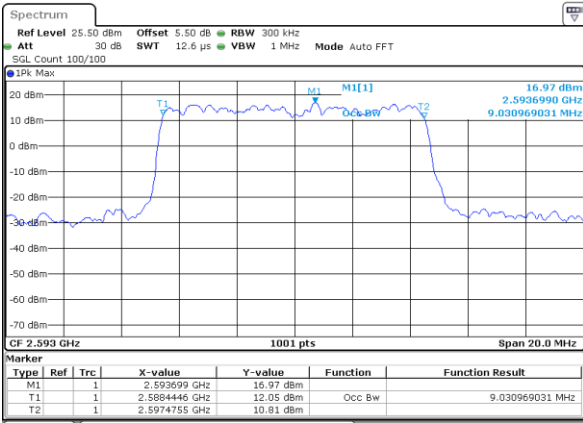

Date: 8 MAR 2019 00:54:17

Middle Channel / 10MHz / 16QAM

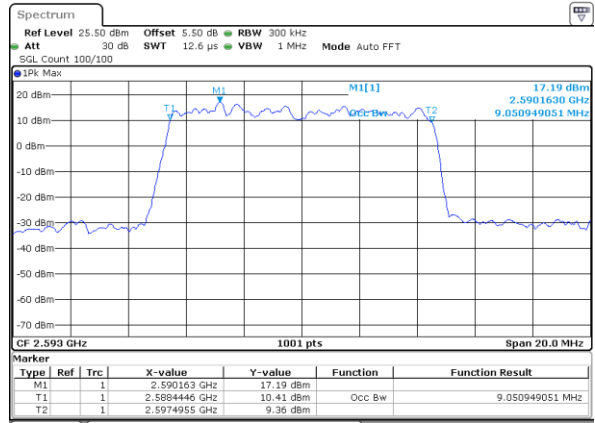

Date: 8 MAR 2019 00:53:44

Highest Channel / 10MHz / QPSK

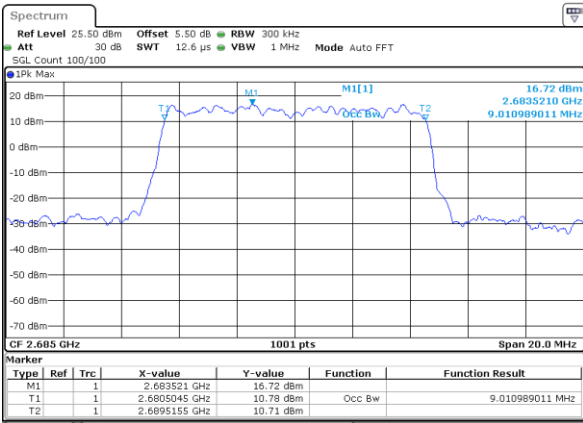

Date: 8 MAR 2019 00:55:04

Highest Channel / 10MHz / 16QAM

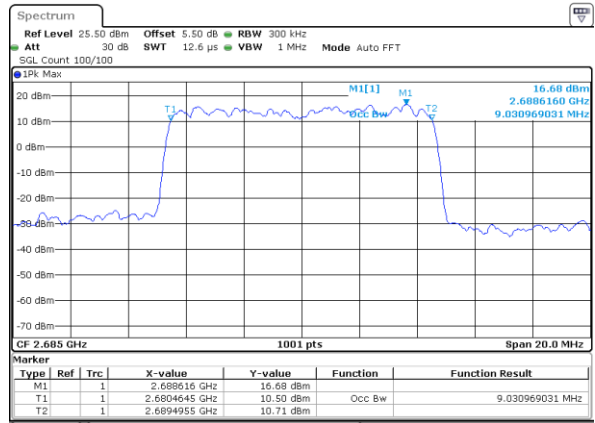

Date: 8 MAR 2019 00:55:25



LTE Band 41

Lowest Channel / 15MHz / QPSK

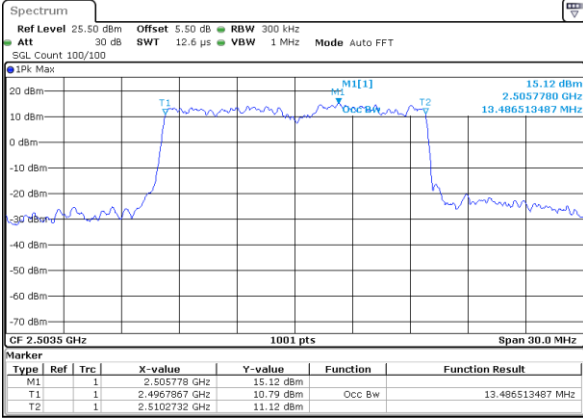

Date: 8 MAR 2019 02:40:02

Lowest Channel / 15MHz / 16QAM

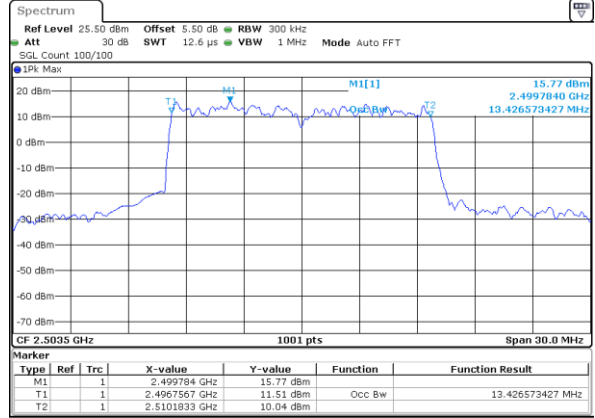

Date: 8 MAR 2019 02:40:23

Middle Channel / 15MHz / QPSK

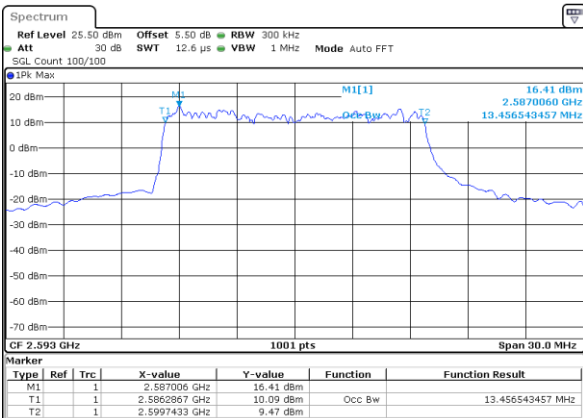

Date: 8 MAR 2019 02:43:31

Middle Channel / 15MHz / 16QAM

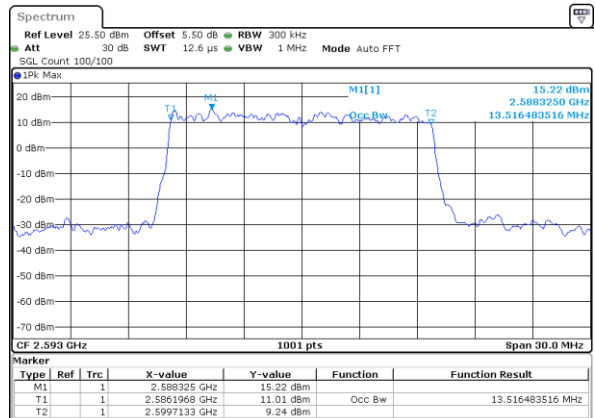

Date: 8 MAR 2019 02:43:07

Highest Channel / 15MHz / QPSK

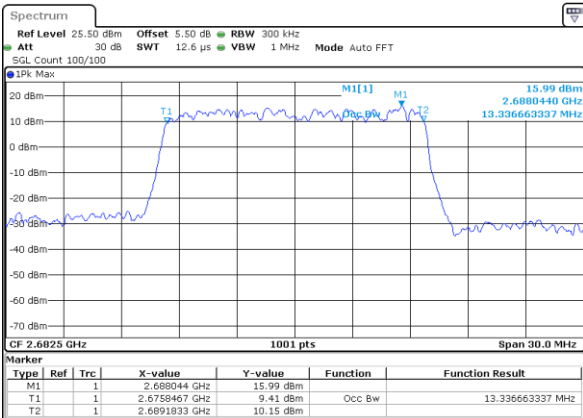

Date: 8 MAR 2019 02:45:16

Highest Channel / 15MHz / 16QAM

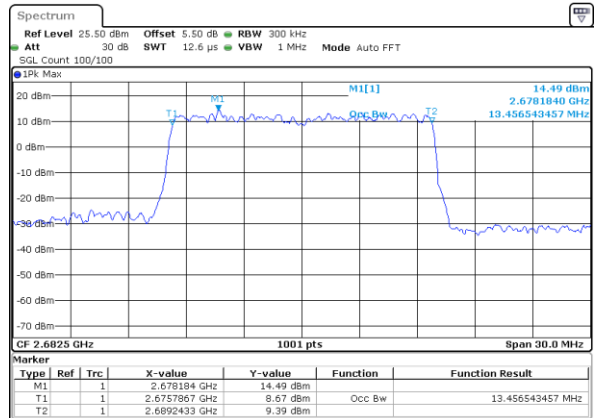

Date: 8 MAR 2019 02:46:01



LTE Band 41

Lowest Channel / 20MHz / QPSK

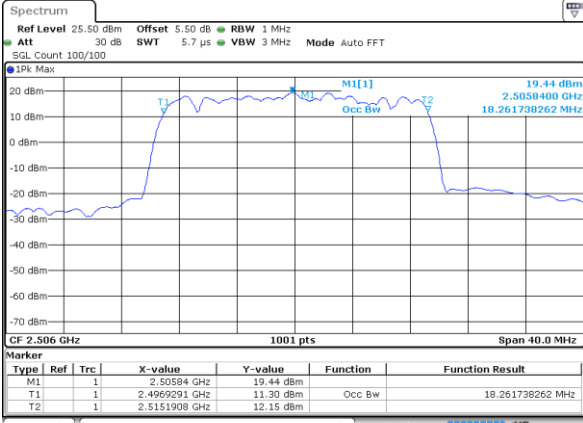

Date: 8 MAR 2019 04:27:44

Lowest Channel / 20MHz / 16QAM

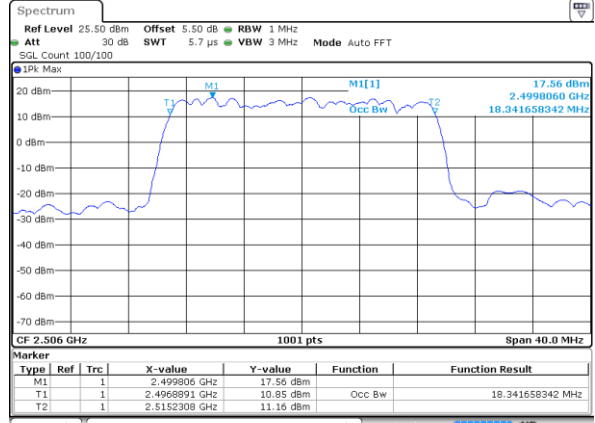

Date: 8 MAR 2019 04:28:08

Middle Channel / 20MHz / QPSK

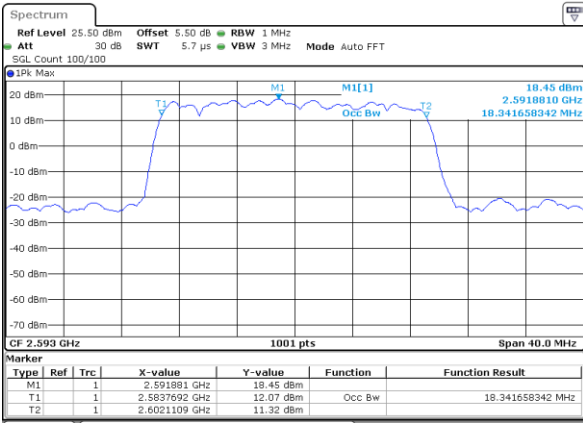

Date: 8 MAR 2019 04:29:47

Middle Channel / 20MHz / 16QAM

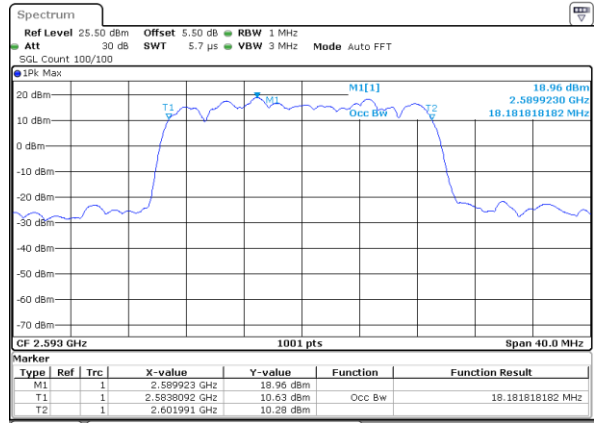

Date: 8 MAR 2019 04:29:25

Highest Channel / 20MHz / QPSK

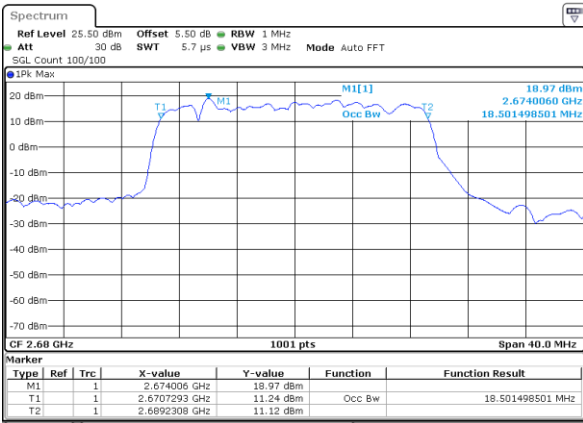

Date: 8 MAR 2019 04:30:26

Highest Channel / 20MHz / 16QAM

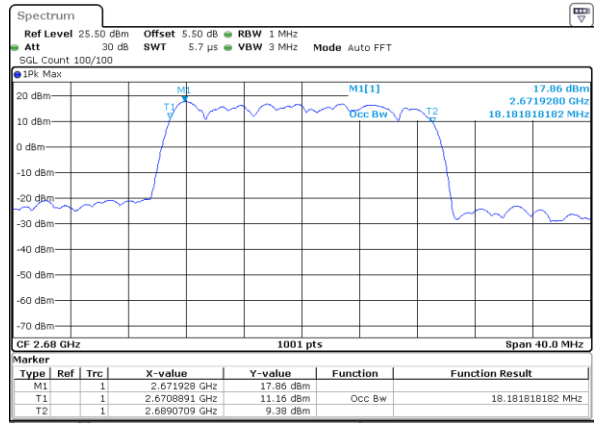

Date: 8 MAR 2019 04:31:15



LTE Band 41

Lowest Channel / 5MHz / 64QAM

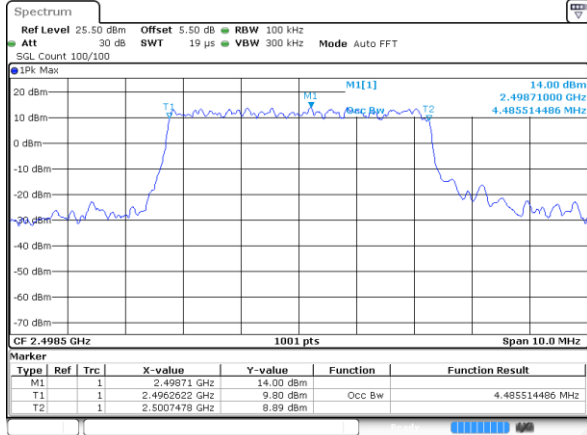

Date: 7 MAR 2019 23:50:30

Lowest Channel / 10MHz / 64QAM

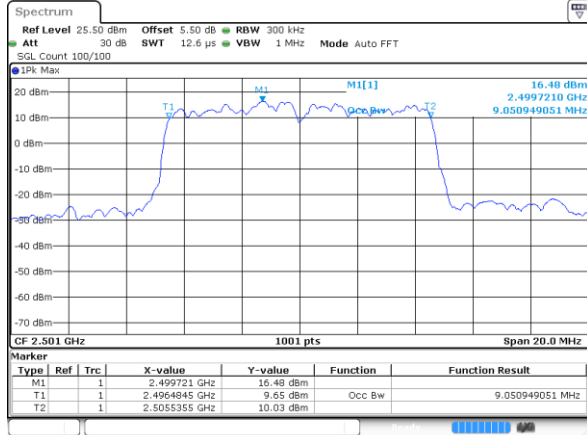

Date: 8 MAR 2019 00:52:57

Middle Channel / 5MHz / 64QAM

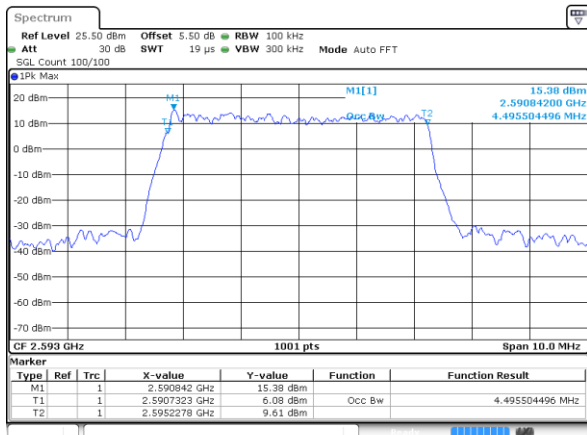

Date: 7 MAR 2019 23:51:41

Middle Channel / 10MHz / 64QAM

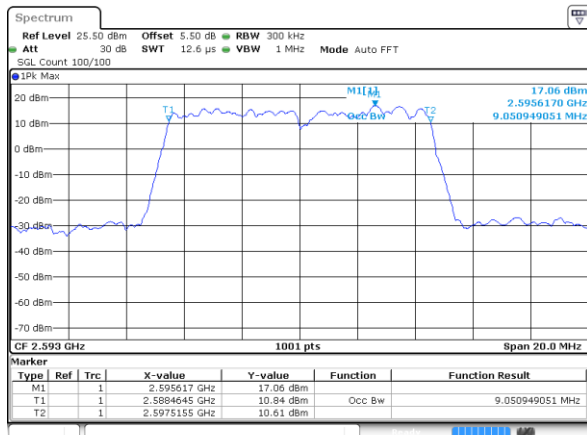

Date: 8 MAR 2019 00:53:21

Highest Channel / 5MHz / 64QAM

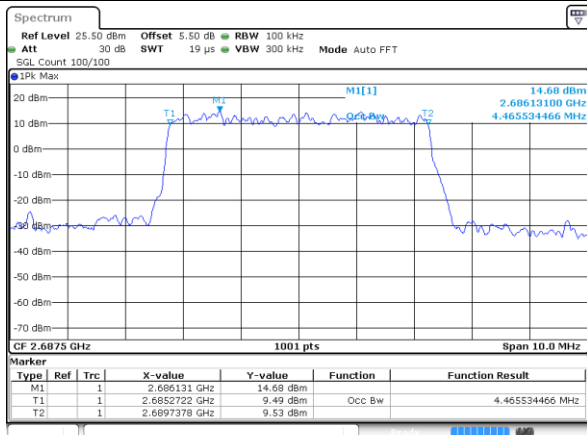

Date: 7 MAR 2019 23:53:27

Highest Channel / 10MHz / 64QAM

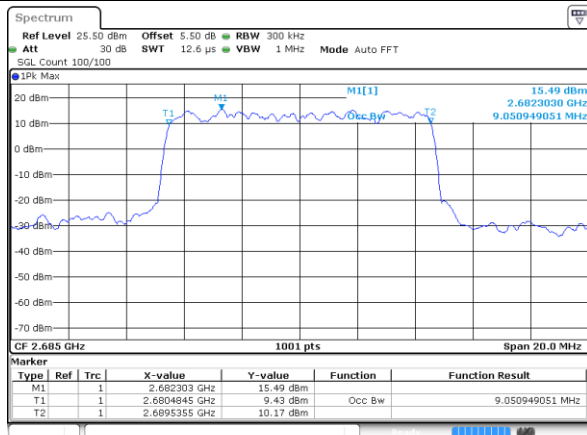

Date: 8 MAR 2019 00:55:45



LTE Band 41

Lowest Channel / 15MHz / 64QAM

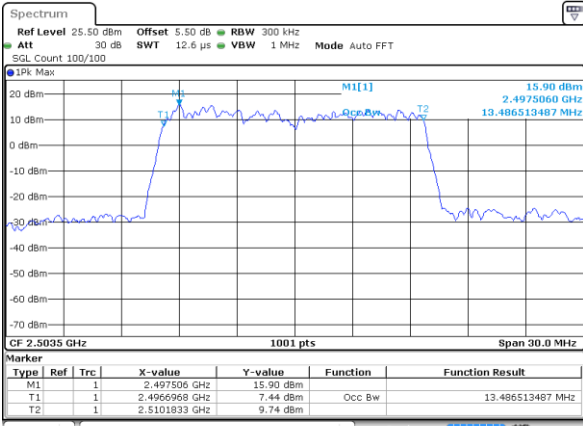

Date: 8 MAR 2019 02:40:42

Lowest Channel / 20MHz / 64QAM

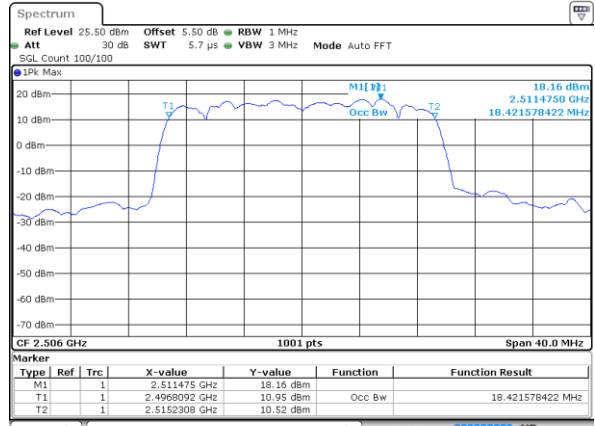

Date: 8 MAR 2019 04:28:29

Middle Channel / 15MHz / 64QAM

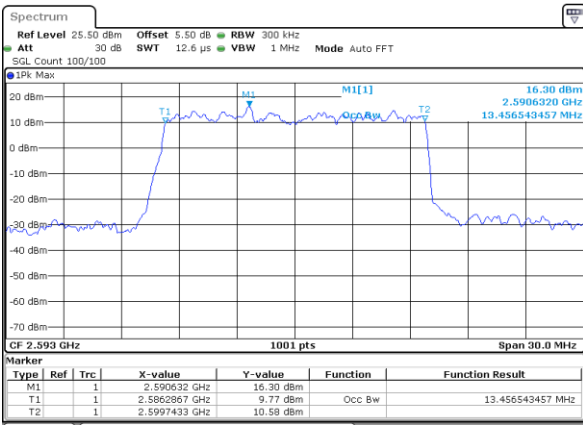

Date: 8 MAR 2019 02:42:42

Middle Channel / 20MHz / 64QAM

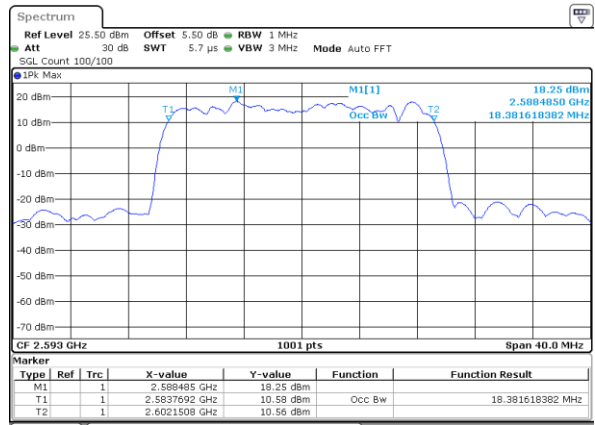

Date: 8 MAR 2019 04:28:51

Highest Channel / 15MHz / 64QAM

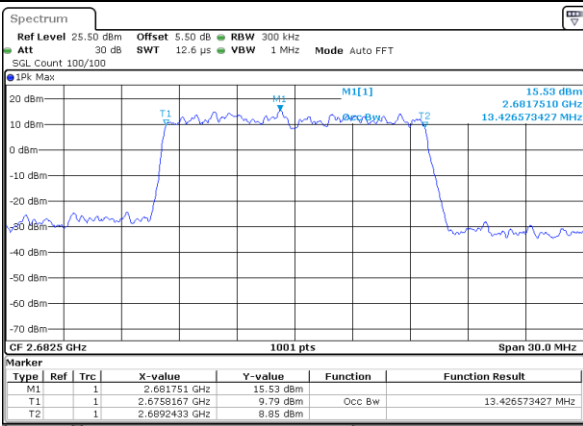

Date: 8 MAR 2019 02:46:22

Highest Channel / 20MHz / 64QAM

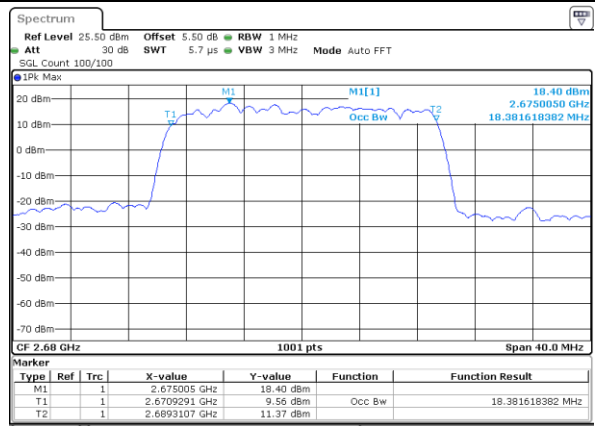

Date: 8 MAR 2019 04:31:40



Conducted Band Edge

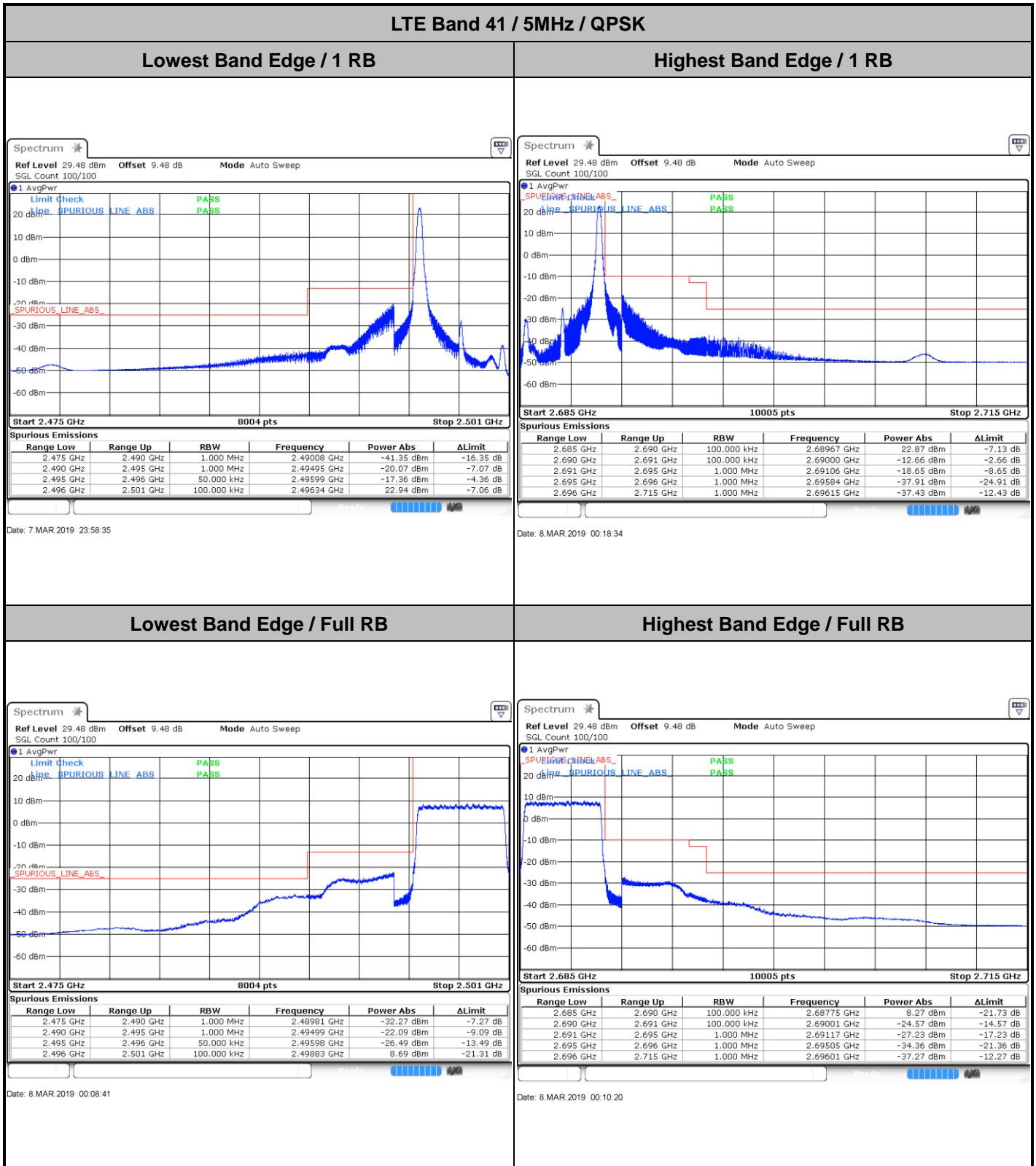



LTE Band 41 / 5MHz / 16QAM

Lowest Band Edge / 1RB

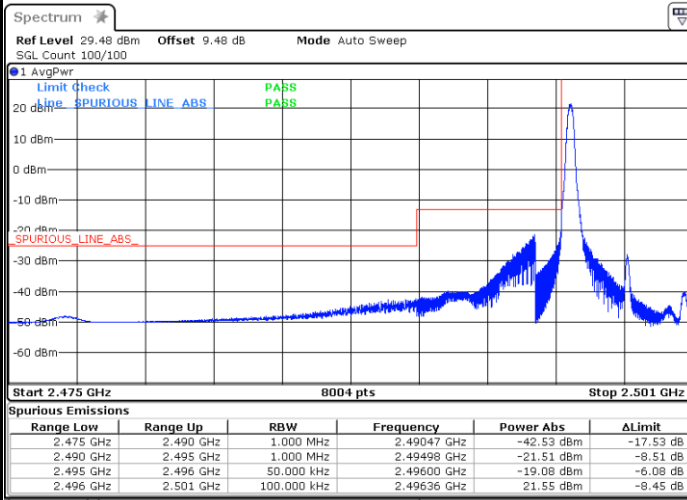

Date: 8 MAR 2019 00:01:49

Highest Band Edge / 1 RB

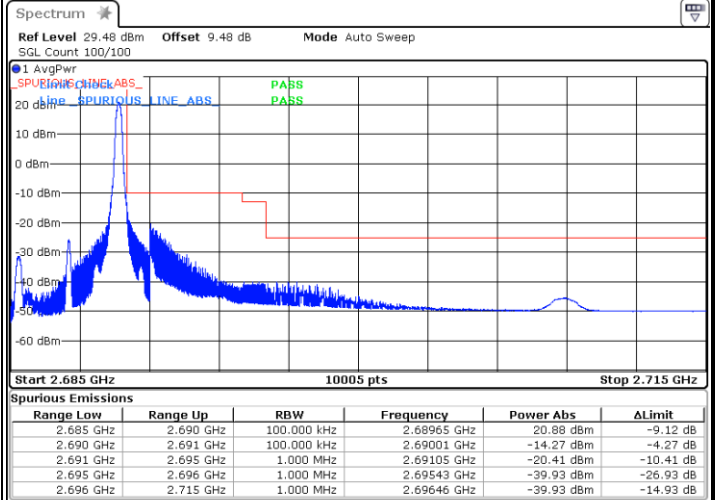

Date: 8 MAR 2019 00:17:13

Lowest Band Edge / Full RB

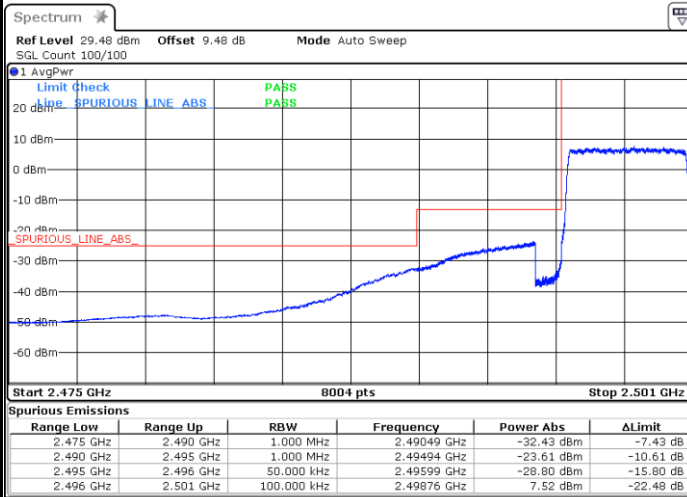

Date: 8 MAR 2019 00:06:52

Highest Band Edge / Full RB

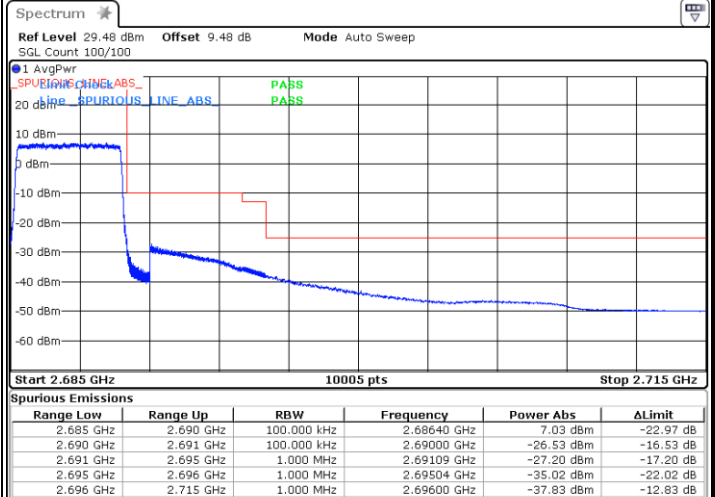

Date: 8 MAR 2019 00:12:02



LTE Band 41 / 10MHz / QPSK

Lowest Band Edge / 1 RB

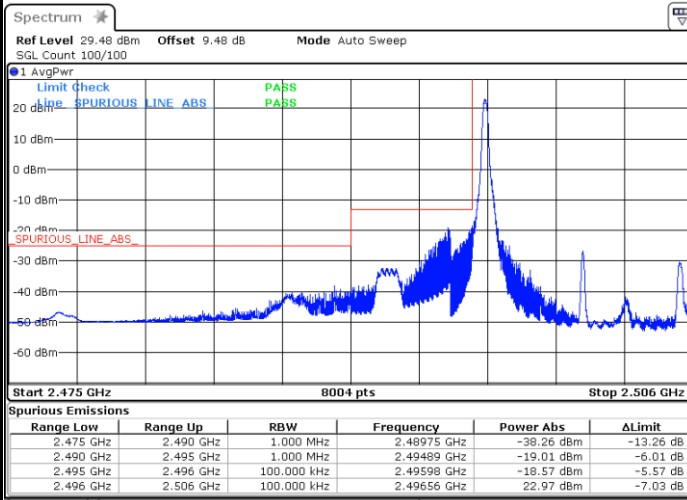

Date: 8 MAR 2019 00:29:14

Highest Band Edge / 1 RB

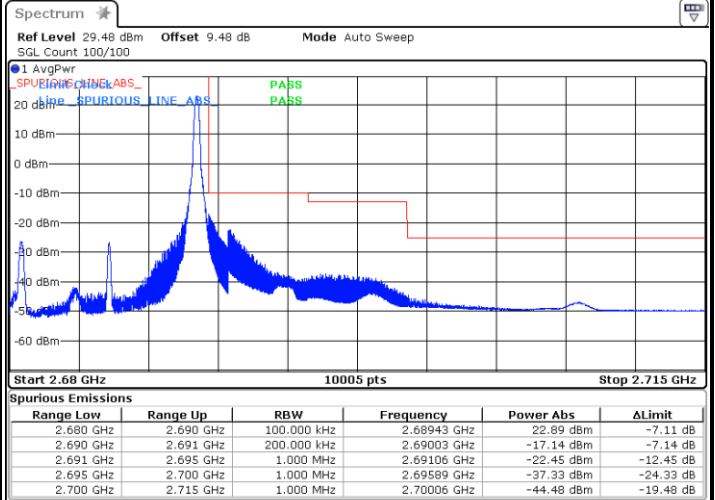

Date: 8 MAR 2019 00:43:50

Lowest Band Edge / Full RB

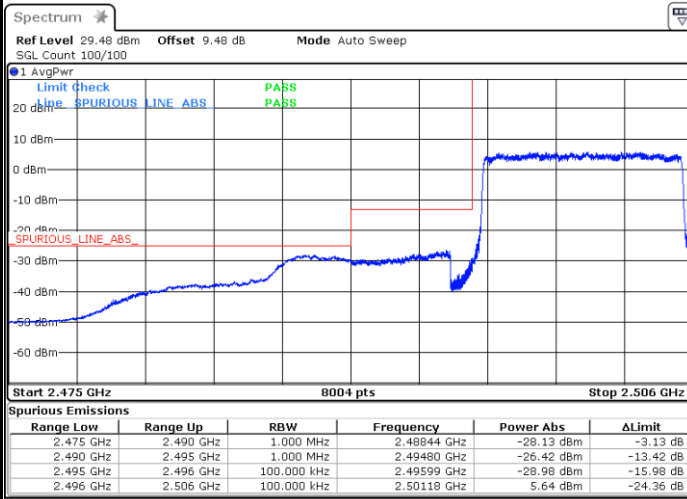

Date: 8 MAR 2019 00:34:33

Highest Band Edge / Full RB

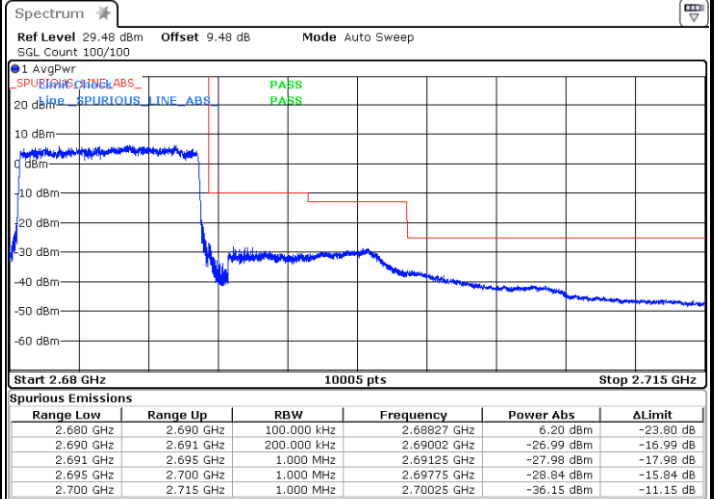

Date: 8 MAR 2019 00:35:31



LTE Band 41 / 10MHz / 16QAM

Lowest Band Edge / 1 RB

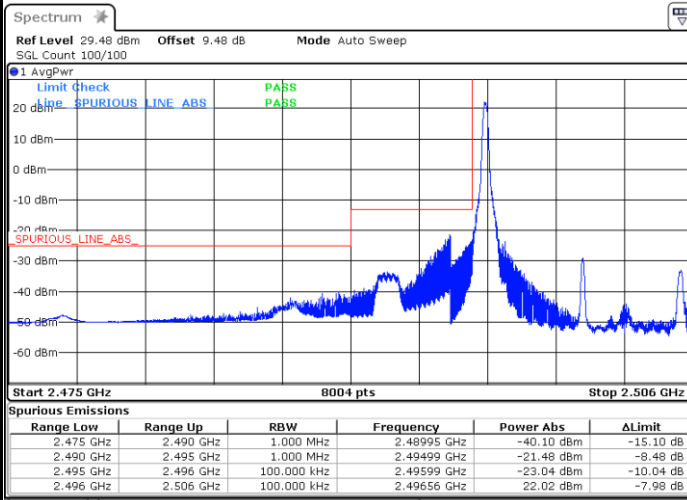

Date: 8 MAR 2019 00:30:52

Highest Band Edge / 1 RB

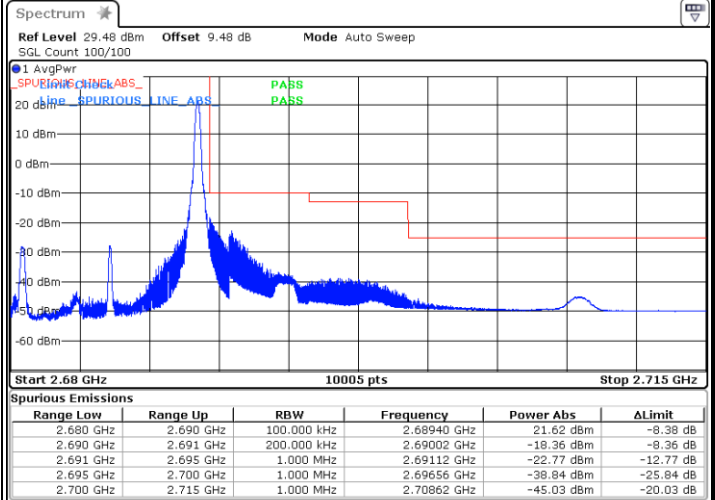

Date: 8 MAR 2019 00:42:24

Lowest Band Edge / Full RB

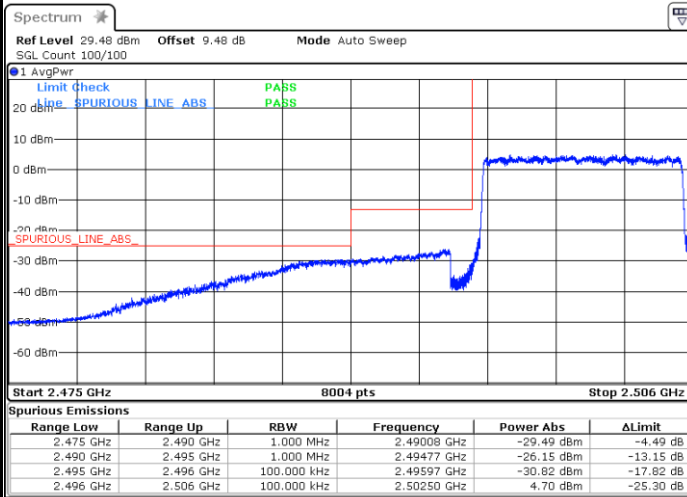

Date: 8 MAR 2019 00:33:56

Highest Band Edge / Full RB

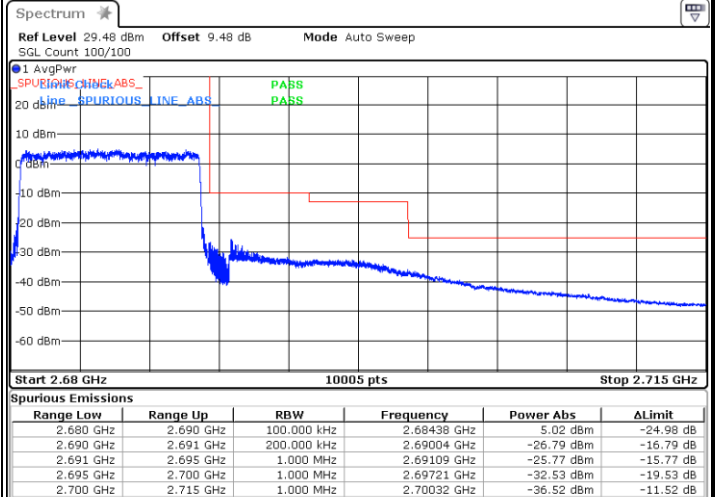

Date: 8 MAR 2019 00:36:15



LTE Band 41 / 15MHz / QPSK

Lowest Band Edge / 1 RB

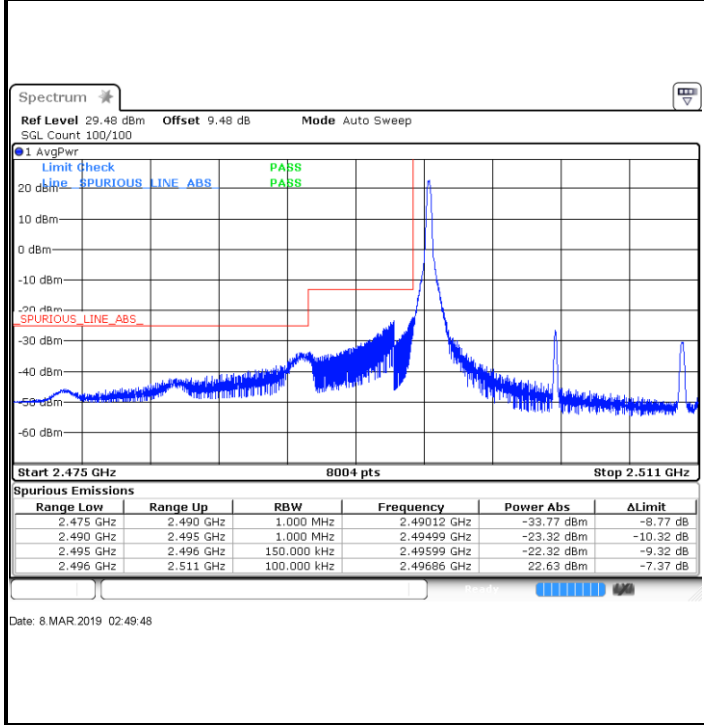

Highest Band Edge / 1 RB

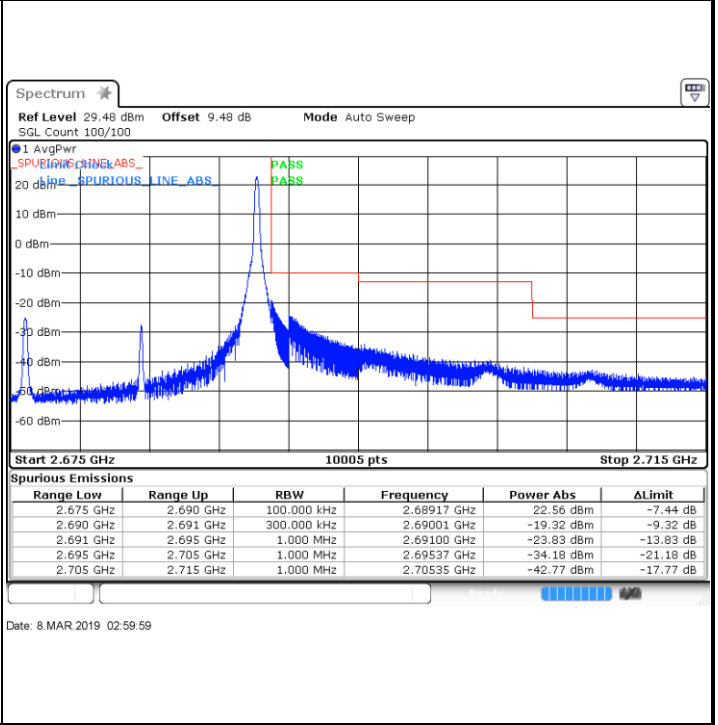

Lowest Band Edge / Full RB

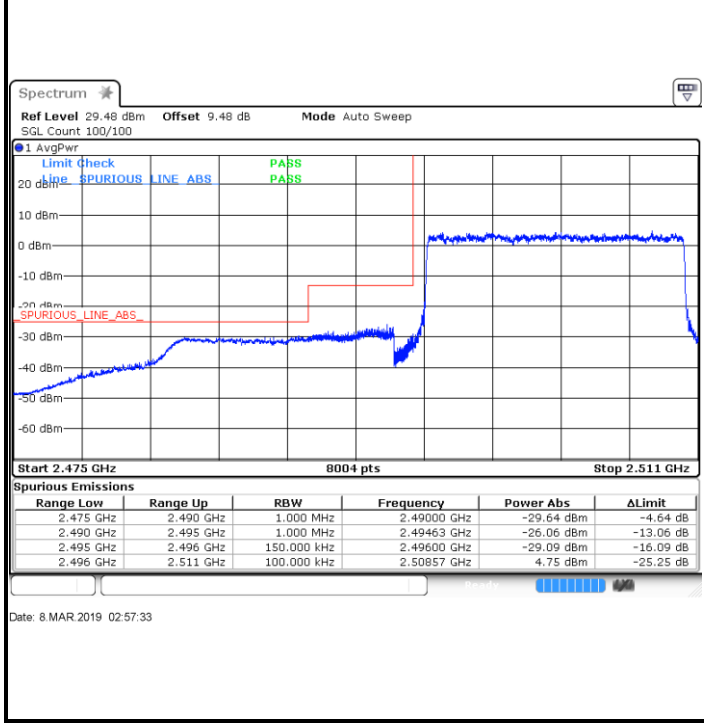

Highest Band Edge / Full RB

