



FCC RF Test Report

APPLICANT : Motorola Mobility LLC
EQUIPMENT : Mobile Cellular Phone
BRAND NAME : Motorola
MODEL NAME : XT1921-5, XT1921-3
FCC ID : IHDT56XC2
STANDARD : FCC Part 15 Subpart E §15.407
CLASSIFICATION : (NII) Unlicensed National Information Infrastructure

The product was received on Dec. 20, 2017 and testing was completed on Jan. 18, 2018. We, SPORTON INTERNATIONAL INC., would like to declare that the tested sample has been evaluated in accordance with the test procedures and has been in compliance with the applicable technical standards.

The test results in this report apply exclusively to the tested model / sample. Without written approval of SPORTON INTERNATIONAL INC., the test report shall not be reproduced except in full.

Reviewed by: Joseph Lin / Supervisor

Approved by: Jones Tsai / Manager



SPORTON INTERNATIONAL INC.

No. 52, Hwa Ya 1st Rd., Hwa Ya Technology Park, Kwei-Shan District, Tao Yuan City, Taiwan, R.O.C.

SPORTON INTERNATIONAL INC.

TEL : 886-3-327-3456

FAX : 886-3-328-4978

FCC ID : IHDT56XC2

Page Number : 1 of 31

Report Issued Date : Feb. 13, 2018

Report Version : Rev. 01

Report Template No.: BU5-FR15EWLAC MA Version 2.0



TABLE OF CONTENTS

REVISION HISTORY.....3

SUMMARY OF TEST RESULT4

1 GENERAL DESCRIPTION5

 1.1 Applicant5

 1.2 Manufacturer.....5

 1.3 Product Feature of Equipment Under Test.....5

 1.4 Product Specification of Equipment Under Test.....6

 1.5 Modification of EUT6

 1.6 Testing Location7

 1.7 Applicable Standards.....7

2 TEST CONFIGURATION OF EQUIPMENT UNDER TEST8

 2.1 Carrier Frequency and Channel8

 2.2 Test Mode 10

 2.3 Connection Diagram of Test System 11

 2.4 Support Unit used in test configuration and system 12

 2.5 EUT Operation Test Setup 12

 2.6 Measurement Results Explanation Example..... 12

3 TEST RESULT.....13

 3.1 26dB & 99% Occupied Bandwidth Measurement 13

 3.2 Maximum Conducted Output Power Measurement 15

 3.3 Power Spectral Density Measurement 17

 3.4 Unwanted Emissions Measurement20

 3.5 AC Conducted Emission Measurement.....26

 3.6 Automatically Discontinue Transmission28

 3.7 Antenna Requirements.....29

4 LIST OF MEASURING EQUIPMENT30

5 UNCERTAINTY OF EVALUATION31

APPENDIX A. CONDUCTED TEST RESULTS

APPENDIX B. AC CONDUCTED EMISSION TEST RESULT

APPENDIX C. RADIATED SPURIOUS EMISSION

APPENDIX D. RADIATED SPURIOUS EMISSION PLOTS

APPENDIX E. DUTY CYCLE PLOTS



SUMMARY OF TEST RESULT

Report Section	FCC Rule	Description	Limit	Result	Remark
3.1	2.1049 15.403(i)	26dB & 99% Bandwidth	-	Pass	-
3.2	15.407(a)	Maximum Conducted Output Power	≤ 24 dBm	Pass	-
3.3	15.407(a)	Power Spectral Density	≤ 11 dBm	Pass	-
3.4	15.407(b)	Unwanted Emissions	15.407(b) & 15.209(a)	Pass	Under limit 3.71 dB at 5350.080 MHz
3.5	15.207	AC Conducted Emission	15.207(a)	Pass	Under limit 16.40 dB at 0.566 MHz
3.6	15.407(c)	Automatically Discontinue Transmission	Discontinue Transmission	Pass	-
3.7	15.203 & 15.407(a)	Antenna Requirement	N/A	Pass	-



1 General Description

1.1 Applicant

Motorola Mobility LLC
222 W. Merchandise Mart Plaza, Chicago IL 60654, USA

1.2 Manufacturer

Motorola Mobility LLC
222 W. Merchandise Mart Plaza, Chicago IL 60654, USA

1.3 Product Feature of Equipment Under Test

Product Feature	
Equipment	Mobile Cellular Phone
Brand Name	Motorola
Model Name	XT1921-5, XT1921-3
FCC ID	IHDT56XC2
IMEI Code	990005440074244 (for Radiation) 990005440016179 (for Conduction)
EUT supports Radios application	CDMA/EV-DO/GSM/EGPRS/WCDMA/HSPA/LTE/FM/GNSS WLAN 11b/g/n HT20 WLAN 11a/n HT20/HT40 Bluetooth BR/EDR/LE
HW Version	DVT1B
EUT Stage	Identical Prototype

Remark: The above EUT's information was declared by manufacturer. Please refer to the specifications or user's manual for more detailed description.

Accessory List	
AC Adapter 1	Brand Name : Motorola
	Model Name : C-P35
AC Adapter 2	Brand Name : Motorola
	Model Name : SSW-2919UMTJ C-P35 SPN5945A
AC Adapter 3	Brand Name : Motorola
	Model Name : C-P56
AC Adapter 4	Brand Name : Motorola
	Model Name : C-P56
Battery	Brand Name : Motorola
	Model Name : GK40
USB Cable	Brand Name : Saibao
	Model Name : SWT-A083A



1.4 Product Specification of Equipment Under Test

Standards-related Product Specification	
Tx/Rx Frequency Range	5180 MHz ~ 5240 MHz 5260 MHz ~ 5320 MHz 5500 MHz ~ 5700 MHz
Maximum Output Power to Antenna	<5180 MHz ~ 5240 MHz> 802.11a : 15.97 dBm / 0.0395 W 802.11n HT20 : 10.98 dBm / 0.0125 W 802.11n HT40 : 9.83 dBm / 0.0096 W <5260 MHz ~ 5320 MHz> 802.11a : 15.97 dBm / 0.0395 W 802.11n HT20 : 10.97 dBm / 0.0125 W 802.11n HT40 : 9.91 dBm / 0.0098 W <5500 MHz ~ 5700 MHz > 802.11a : 15.87 dBm / 0.0386 W 802.11n HT20 : 10.96 dBm / 0.0125 W 802.11n HT40 : 9.93 dBm / 0.0098 W
99% Occupied Bandwidth	802.11a : 19.40 MHz 802.11n HT20 : 19.10 MHz 802.11n HT40 : 36.80 MHz
Antenna Type / Gain	<5150 MHz ~ 5250 MHz> PIFA Antenna with gain -3.78 dBi <5250 MHz ~ 5350 MHz> PIFA Antenna with gain -3.53 dBi <5470 MHz ~ 5725 MHz> PIFA Antenna with gain -3.97 dBi
Type of Modulation	802.11a/n : OFDM (BPSK / QPSK / 16QAM / 64QAM)

1.5 Modification of EUT

No modifications are made to the EUT during all test items.



1.6 Testing Location

Sporton Lab is accredited to ISO 17025 by Taiwan Accreditation Foundation (TAF code : 1190) and the FCC designation No. TW1190 and TW0007 under the FCC 2.948(e) by Mutual Recognition Agreement (MRA) in FCC Test.

Test Site	SPORTON INTERNATIONAL INC.	
Test Site Location	No. 52, Hwa Ya 1 st Rd., Hwa Ya Technology Park, Kwei-Shan District, Tao Yuan City, Taiwan, R.O.C. TEL: +886-3-327-3456 FAX: +886-3-328-4978	
Test Site No.	Sporton Site No.	
	TH05-HY	CO05-HY

Note: The test site complies with ANSI C63.4 2014 requirement.

Test Site	SPORTON INTERNATIONAL INC.	
Test Site Location	No.58, Aly. 75, Ln. 564, Wenhua 3rd Rd. Guishan Dist, Taoyuan City, Taiwan (R.O.C.) TEL: +886-3-327-0868 FAX: +886-3-327-0855	
Test Site No.	Sporton Site No.	
	03CH11-HY	

1.7 Applicable Standards

According to the specifications of the manufacturer, the EUT must comply with the requirements of the following standards:

- ♦ FCC Part 15 Subpart E
- ♦ FCC KDB 789033 D02 General UNII Test Procedures New Rules v02r01.
- ♦ ANSI C63.10-2013

Remark:

1. All test items were verified and recorded according to the standards and without any deviation during the test.
2. This EUT has also been tested and complied with the requirements of FCC Part 15, Subpart B, recorded in a separate test report.



2 Test Configuration of Equipment Under Test

- a. The EUT has been associated with peripherals and configuration operated in a manner tended to maximize its emission characteristics in a typical application. Frequency range investigated: conduction emission (150 kHz to 30 MHz), radiation emission (9 kHz to the 10th harmonic of the highest fundamental frequency or to 40 GHz, whichever is lower). For radiated measurement, pre-scanned in three orthogonal panels, X, Y, Z. The worst cases (X plane) were recorded in this report.
- b. AC power line Conducted Emission was tested under maximum output power.

2.1 Carrier Frequency and Channel

Frequency Band	Channel	Freq. (MHz)	Channel	Freq. (MHz)
5150-5250 MHz Band 1 (U-NII-1)	36	5180	44	5220
	38*	5190	46*	5230
	40	5200	48	5240
	-	-		
Frequency Band	Channel	Freq. (MHz)	Channel	Freq. (MHz)
5250-5350 MHz Band 2 (U-NII-2A)	52	5260	60	5300
	54*	5270	62*	5310
	56	5280	64	5320
	-	-		
Frequency Band	Channel	Freq. (MHz)	Channel	Freq. (MHz)
5470-5725 MHz Band 3 (U-NII-2C)	100	5500	112	5560
	102*	5510	116	5580
	104	5520	132	5660
	-	-	134*	5670
	108	5540	136	5680
	110*	5550	140	5700



Frequency Band	Channel	Freq. (MHz)	Channel	Freq. (MHz)
TDWR Channel	118*	5590	124	5620
	120	5600	126*	5630
	-	-	128	5640

Note: The above Frequency and Channel in "*" were 802.11n HT40.



2.2 Test Mode

Final test modes are considering the modulation and worse data rates as below table.

Modulation	Data Rate
802.11a	6 Mbps
802.11n HT20	MCS0
802.11n HT40	MCS0

Test Cases	
AC Conducted Emission	Mode 1 : GSM 1900 Idle + Bluetooth Link + WLAN (5GHz) Link + MP3 + SD Card + USB Cable (Charging from Adapter 1) + Earphone
Remark: For Radiated Test Cases, The tests were performance with Adapter 1.	

Ch. #		Band I : 5150-5250 MHz	Band II : 5250-5350 MHz	Band III : 5470-5725MHz
		802.11a	802.11a	802.11a
L	Low	36	52	100
M	Middle	44	60	116
H	High	48	64	140

Ch. #		Band I : 5150-5250 MHz	Band II : 5250-5350 MHz	Band III : 5470-5725MHz
		802.11n HT20	802.11n HT20	802.11n HT20
L	Low	36	52	100
M	Middle	44	60	116
H	High	48	64	140

Ch. #		Band I : 5150-5250 MHz	Band II : 5250-5350 MHz	Band III : 5470-5725MHz
		802.11n HT40	802.11n HT40	802.11n HT40
L	Low	38	54	102
M	Middle	-	-	110
H	High	46	62	134

2.3 Connection Diagram of Test System

<WLAN Tx Mode>

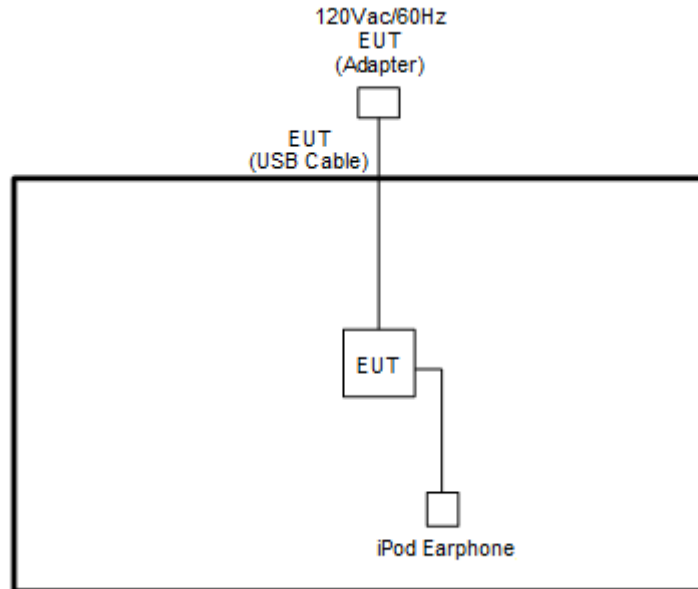

<AC Conducted Emission Mode>

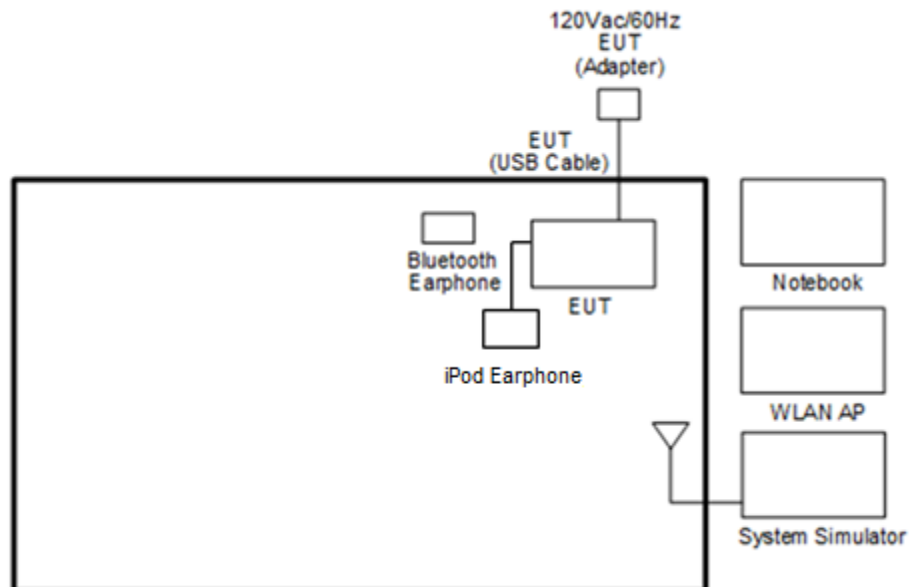



2.4 Support Unit used in test configuration and system

Item	Equipment	Trade Name	Model Name	FCC ID	Data Cable	Power Cord
1.	System Simulator	Anritsu	MT8820C	N/A	N/A	Unshielded, 1.8 m
2.	Bluetooth Earphone	Sony Ericsson	MW600	PY7DDA-2029	N/A	N/A
3.	WLAN AP	ASUS	RT-AC66U	MSQ-RTAC66U	N/A	Unshielded, 1.8 m
4.	iPod Earphone	Apple	A1285	FCC DoC	Shielded, 1.0 m	N/A
5.	Notebook	DELL	Latitude E6320	FCC DoC/ Contains FCC ID: QDS-BRCM1054	N/A	AC I/P: Unshielded, 1.2 m DC O/P: Shielded, 1.8 m
6.	SD Card	SanDisk	MicroSD HC	FCC DoC	N/A	N/A

2.5 EUT Operation Test Setup

The RF test items, utility “QRCT” was installed in Notebook which was programmed in order to make the EUT get into the engineering modes to provide channel selection, power level, data rate and the application type and for continuous transmitting signals.

2.6 Measurement Results Explanation Example

For all conducted test items:

The offset level is set in the spectrum analyzer to compensate the RF cable loss and attenuator factor between EUT conducted output port and spectrum analyzer. With the offset compensation, the spectrum analyzer reading level is exactly the EUT RF output level.

Example :

The spectrum analyzer offset is derived from RF cable loss and attenuator factor.

Offset = RF cable loss + attenuator factor.

Following shows an offset computation example with cable loss 4.2 dB and 10dB attenuator.

Offset(dB) = RF cable loss(dB) + attenuator factor(dB).

$$= 4.2 + 10 = 14.2 \text{ (dB)}$$

3 Test Result

3.1 26dB & 99% Occupied Bandwidth Measurement

3.1.1 Description of 26dB & 99% Occupied Bandwidth

This section is for reporting purpose only.

There is no restriction limits for bandwidth.

For Straddle Channel, According to KDB 789033 D02 General UNII Test Procedures New Rules v02r01, If the power and PSD of the devices are uniform and comply with the lower limits specified for the U-NII-2 bands, a single measurement over the entire emission bandwidth can be performed to show compliance.

3.1.2 Measuring Instruments

The measuring equipment is listed in the section 4 of this test report.

3.1.3 Test Procedures

1. The testing follows FCC KDB 789033 D02 General UNII Test Procedures New Rules v02r01. Section C) Emission bandwidth
2. Set RBW = approximately 1% of the emission bandwidth.
3. Set the VBW > RBW.
4. Detector = Peak.
5. Trace mode = max hold
6. Measure the maximum width of the emission that is 26 dB down from the peak of the emission. Compare this with the RBW setting of the analyzer. Readjust RBW and repeat measurement as needed until the RBW/EBW ratio is approximately 1%.
7. For 99% Bandwidth Measurement, the spectrum analyzer's resolution bandwidth (RBW) is set 1MHz and set the Video bandwidth (VBW) $\geq 3 * RBW$.
8. Measure and record the results in the test report.

3.1.4 Test Setup

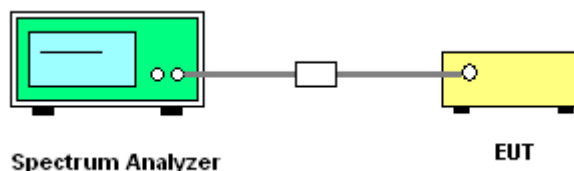

3.1.5 Test Result of 26dB & 99% Occupied Bandwidth

Please refer to Appendix A.

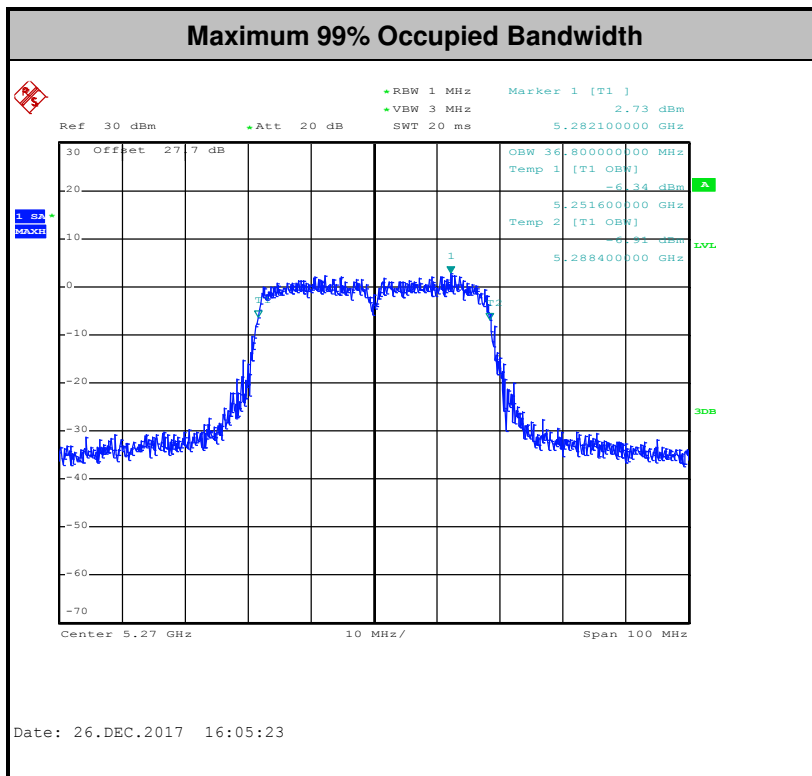
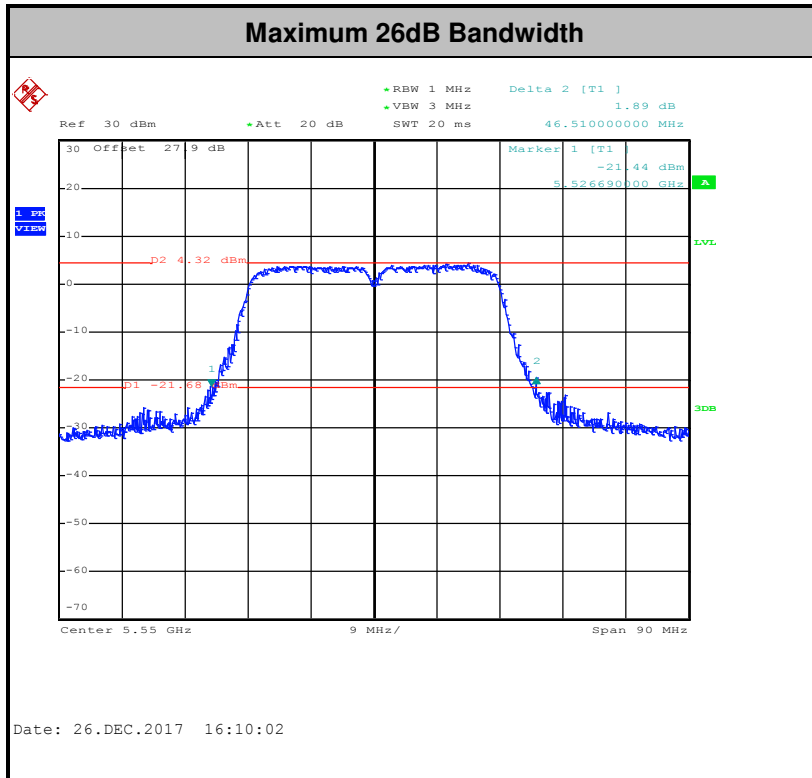

Note: The occupied channel bandwidth is maintained within the band of operation for all of the modulations.



3.2 Maximum Conducted Output Power Measurement

3.2.1 Limit of Maximum Conducted Output Power

<FCC 14-30 CFR 15.407>

For mobile and portable client devices in the 5.15–5.25 GHz band, the maximum conducted output power over the frequency band of operation shall not exceed 250 mW.

For the 5.25–5.725 GHz bands, the maximum conducted output power over the frequency bands of operation shall not exceed the lesser of 250 mW or 11 dBm $10 \log B$, where B is the 26 dB emission bandwidth in megahertz.

For Straddle Channel, According to KDB 789033 D02 General UNII Test Procedures New Rules v02r01, If the power and PSD of the devices are uniform and comply with the lower limits specified for the U-NII-2 bands, a single measurement over the entire emission bandwidth can be performed to show compliance.

If transmitting antennas of directional gain greater than 6 dBi are used, the peak output power shall be reduced by the amount in dB that the directional gain of the antenna exceeds 6 dBi.

Note that U-NII-2 band, devices with a maximum e.i.r.p. greater than 500 mW shall implement TPC in order to have the capability to operate at least 6 dB below the maximum permitted e.i.r.p. of 1 W.

3.2.2 Measuring Instruments

The measuring equipment is listed in the section 4 of this test report.

3.2.3 Test Procedures

The testing follows Method PM of FCC KDB 789033 D02 General UNII Test Procedures New Rules v02r01.

Method PM (Measurement using an RF average power meter):

1. Measurement is performed using a wideband RF power meter.
2. The EUT is configured to transmit continuously with a consistent duty cycle at its maximum power control level.
3. Measure the average power of the transmitter, and the average power is corrected with duty factor, $10 \log(1/x)$, where x is the duty cycle.

3.2.4 Test Setup

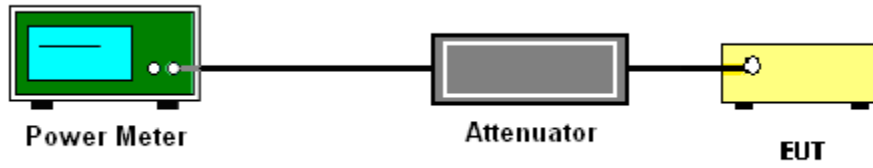

3.2.5 Test Result of Maximum Conducted Output Power

Please refer to Appendix A.



3.3 Power Spectral Density Measurement

3.3.1 Limit of Power Spectral Density

<FCC 14-30 CFR 15.407>

For an indoor access point operating in the band 5.15-5.25 GHz, the maximum power spectral density shall not exceed 17 dBm in any 1 megahertz band.

For the 5.25–5.725 GHz bands, the maximum power spectral density shall not exceed 11 dBm in any 1 megahertz band.

For Straddle Channel, According to KDB 789033 D02 General UNII Test Procedures New Rules v02r01, If the power and PSD of the devices are uniform and comply with the lower limits specified for the U-NII-2 bands, a single measurement over the entire emission bandwidth can be performed to show compliance.

If transmitting antennas of directional gain greater than 6 dBi are used, the peak output power shall be reduced by the amount in dB that the directional gain of the antenna exceeds 6 dBi.

3.3.2 Measuring Instruments

The measuring equipment is listed in the section 4 of this test report.

3.3.3 Test Procedures

The testing follows FCC KDB 789033 D02 General UNII Test Procedures New Rules v02r01.
Section F) Maximum power spectral density.

Method SA-2

(trace averaging across on and off times of the EUT transmissions, followed by duty cycle correction).

- Measure the duty cycle.
 - Set span to encompass the entire emission bandwidth (EBW) of the signal.
 - Set RBW = 1 MHz.
 - Set VBW \geq 3 MHz.
 - Number of points in sweep \geq 2 Span / RBW.
 - Sweep time = auto.
 - Detector = RMS
 - Trace average at least 100 traces in power averaging mode.
 - Add $10 \log(1/x)$, where x is the duty cycle, to the measured power in order to compute the average power during the actual transmission times. For example, add $10 \log(1/0.25) = 6$ dB if the duty cycle is 25 percent.
1. The RF output of EUT was connected to the spectrum analyzer by a low loss cable.
 2. Each plot has already offset with cable loss, and attenuator loss. Measure the PPSD and record it.

3.3.4 Test Setup

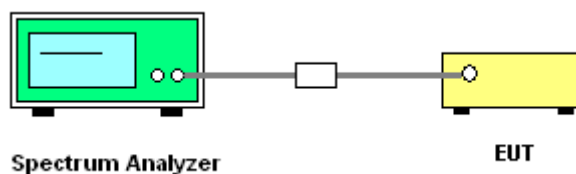

3.3.5 Test Result of Power Spectral Density

Please refer to Appendix A.

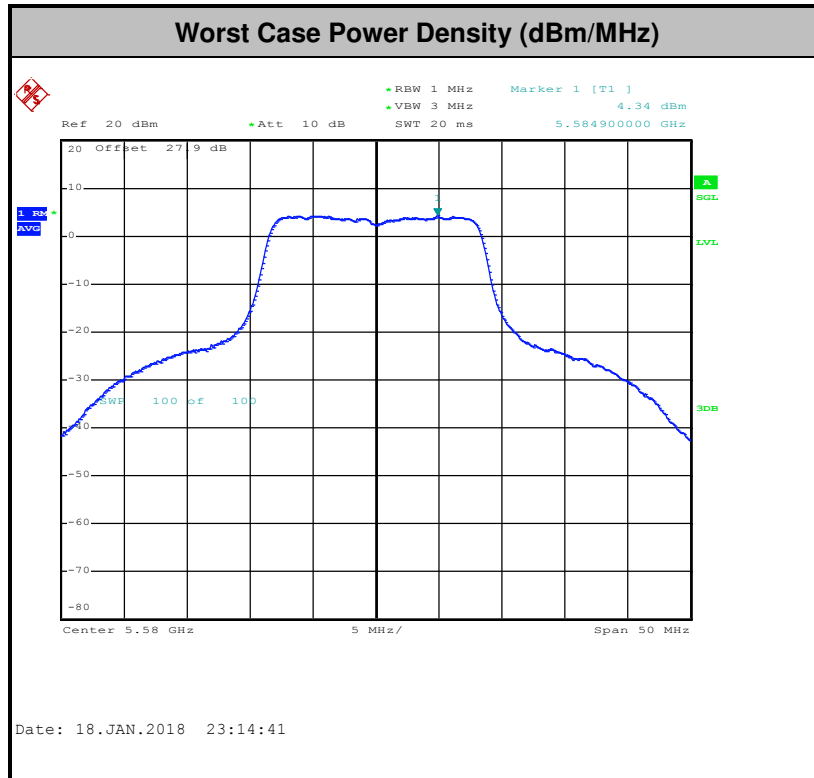

Note: Average Power Density (dB) = Measured value+ Duty Factor



3.4 Unwanted Emissions Measurement

This section is to measure unwanted emissions through radiated measurement for band edge spurious emissions and out of band emissions measurement.

3.4.1 Limit of Unwanted Emissions

- (1) For transmitters operating in the 5150-5250 MHz band: all emissions outside of the 5150-5350 MHz band shall not exceed an EIRP of -27dBm/MHz.

For transmitters operating in the 5250-5350 MHz band: all emissions outside of the 5150-5350 MHz band shall not exceed an EIRP of -27 dBm/MHz. Devices operating in the 5250-5350 MHz band that generate emissions in the 5150-5250 MHz band must meet all applicable technical requirements for operation in the 5150-5250 MHz band (including indoor use) or alternatively meet an out-of-band emission EIRP limit of -27 dBm/MHz in the 5150-5250 MHz band.

For transmitters operating in the 5470-5600 MHz and 5650-5725MHz band: all emissions outside of the 5470-5600 MHz and 5650-5725MHz band shall not exceed an EIRP of -27 dBm/MHz.

- (2) Unwanted spurious emissions fallen in restricted bands shall comply with the general field strength limits as below table,

Frequency (MHz)	Field Strength (microvolts/meter)	Measurement Distance (meters)
0.009 – 0.490	2400/F(kHz)	300
0.490 – 1.705	24000/F(kHz)	30
1.705 – 30.0	30	30
30 – 88	100	3
88 – 216	150	3
216 - 960	200	3
Above 960	500	3

Note: The following formula is used to convert the EIRP to field strength.

$$E = \frac{1000000\sqrt{30P}}{3} \mu\text{V/m, where P is the eirp (Watts)}$$



EIRP (dBm)	Field Strength at 3m (dBμV/m)
-17	78.3
- 27	68.3

(3) KDB789033 D02 v02r01 G)2)c)

- (i) Section 15.407(b)(1) to (b)(3) specify the unwanted emission limits for the U-NII-1 and U-NII-2 bands. As specified, emissions above 1000 MHz that are outside of the restricted bands are subject to a peak emission limit of -27 dBm/MHz.³
- (ii) Section 15.407(b)(4) specifies the unwanted emission limit for the U-NII-3 band. A band emissions mask is specified in Section 15.407(b)(4)(i). The emission limits are in terms of a Peak detector. An alternative to the band emissions mask is specified in Section 15.407(b)(4)(ii). The alternative limits are based on the highest antenna gain specified in the filing. There are also marketing and importation restrictions for the devices using the alternative limit.⁴

Note 3: An out-of-band emission that complies with both the average and peak limits of Section 15.209 is not required to satisfy the -27 dBm/MHz peak emission limit.

Note 4: Only devices with antenna gains of 10 dBi or less may be approved using the emission limits specified in Section 15.247(d) till March 2, 2018; all other devices operating in this band must use the mask specified in Section 15.407(b)(4)(i).



3.4.2 Measuring Instruments

The measuring equipment is listed in the section 4 of this test report.

3.4.3 Test Procedures

1. The testing follows FCC KDB 789033 D02 General UNII Test Procedures New Rules v02r01. Section G) Unwanted emissions measurement.

(1) Procedure for Unwanted Emissions Measurements Below 1000MHz

- RBW = 120 kHz
- VBW = 300 kHz
- Detector = Peak
- Trace mode = max hold

(2) Procedure for Peak Unwanted Emissions Measurements Above 1000 MHz

- RBW = 1 MHz
- VBW \geq 3 MHz
- Detector = Peak
- Sweep time = auto
- Trace mode = max hold

(3) Procedures for Average Unwanted Emissions Measurements Above 1000MHz

- RBW = 1 MHz
- VBW = 10 Hz, when duty cycle is no less than 98 percent.
- VBW \geq 1/T, when duty cycle is less than 98 percent where T is the minimum transmission duration over which the transmitter is on and is transmitting at its maximum power control level for the tested mode of operation.



2. The EUT was placed on a turntable with 0.8 meter for frequency below 1GHz and 1.5 meter for frequency above 1GHz respectively above ground.
3. The EUT was set 3 meters from the interference receiving antenna which was mounted on the top of a variable height antenna tower.
4. The antenna is a broadband antenna and its height is adjusted between one meter and four meters above ground to find the maximum value of the field strength for both horizontal polarization and vertical polarization of the antenna.
5. For each suspected emission, the EUT was arranged to its worst case and then adjust the antenna tower (from 1 m to 4 m) and turntable (from 0 degree to 360 degrees) to find the maximum reading.
6. For testing below 1GHz, if the emission level of the EUT in peak mode was 3 dB lower than the limit specified, then peak values of EUT will be reported, otherwise, the emissions will be repeated one by one using the CISPR quasi-peak method and reported.
7. For testing above 1GHz, the emission level of the EUT in peak mode was 20dB lower than average limit (that means the emission level in average mode also complies with the limit in average mode), then peak values of EUT will be reported, otherwise, the emissions will be measured in average mode again and reported.

3.4.4 Test Setup

For radiated emissions below 30MHz

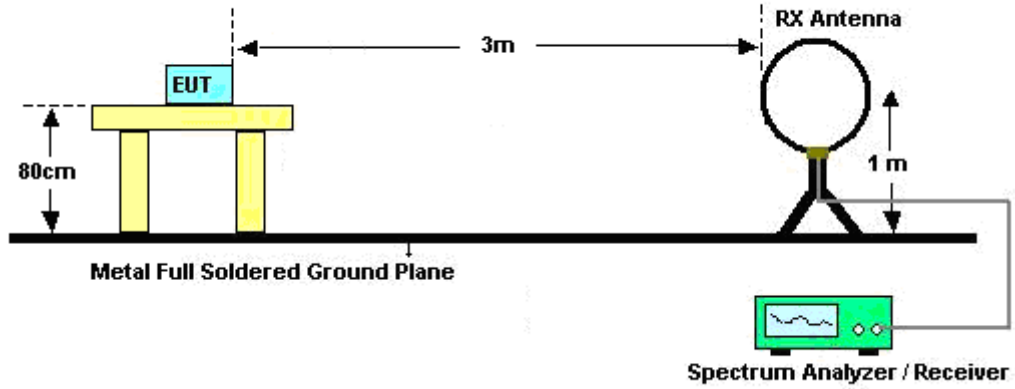

For radiated emissions from 30MHz to 1GHz

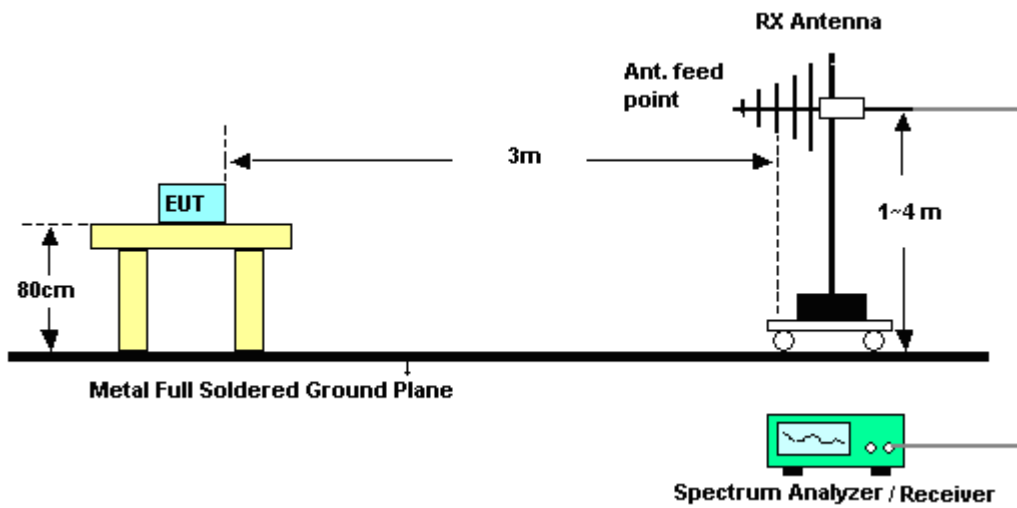

For radiated emissions above 1GHz

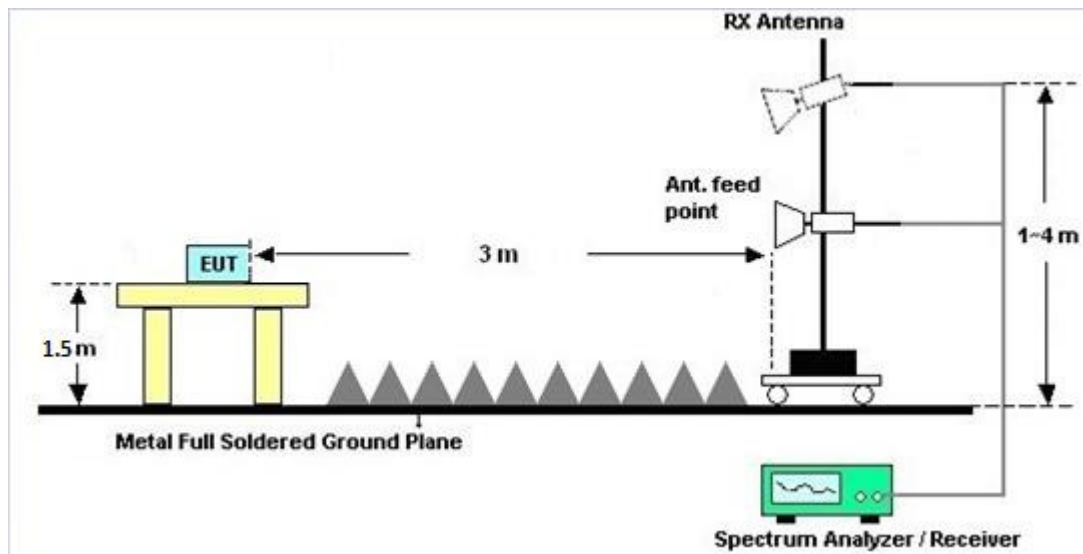

3.4.5 Test Results of Radiated Spurious Emissions (9 kHz ~ 30 MHz)

The low frequency, which started from 9 kHz to 30MHz, was pre-scanned and the result which was 20dB lower than the limit line was not reported.

There is a comparison data of both open-field test site and semi-Anechoic chamber, and the result came out very similar.

3.4.6 Test Result of Radiated Spurious at Band Edges

Please refer to Appendix C and D.

3.4.7 Duty Cycle

Please refer to Appendix E.

3.4.8 Test Result of Radiated Spurious Emissions (30MHz ~ 10th Harmonic)

Please refer to Appendix C and D.



3.5 AC Conducted Emission Measurement

3.5.1 Limit of AC Conducted Emission

For equipment that is designed to be connected to the public utility (AC) power line, the radio frequency voltage that is conducted back onto the AC power line on any frequency or frequencies within the band 150 kHz to 30 MHz shall not exceed the limits in the following table.

Frequency of emission (MHz)	Conducted limit (dB μ V)	
	Quasi-peak	Average
0.15-0.5	66 to 56*	56 to 46*
0.5-5	56	46
5-30	60	50

*Decreases with the logarithm of the frequency.

3.5.2 Measuring Instruments

The measuring equipment is listed in the section 4 of this test report.

3.5.3 Test Procedures

1. The EUT was placed 0.4 meter from the conducting wall of the shielding room was kept at least 80 centimeters from any other grounded conducting surface.
2. Connect EUT to the power mains through a line impedance stabilization network (LISN).
3. All the support units are connecting to the other LISN.
4. The LISN provides 50 ohm coupling impedance for the measuring instrument.
5. The FCC states that a 50 ohm, 50 microhenry LISN should be used.
6. Both sides of AC line were checked for maximum conducted interference.
7. The frequency range from 150 kHz to 30 MHz was searched.
8. Set the test-receiver system to Peak Detect Function and specified bandwidth with Maximum Hold Mode.

3.5.4 Test Setup

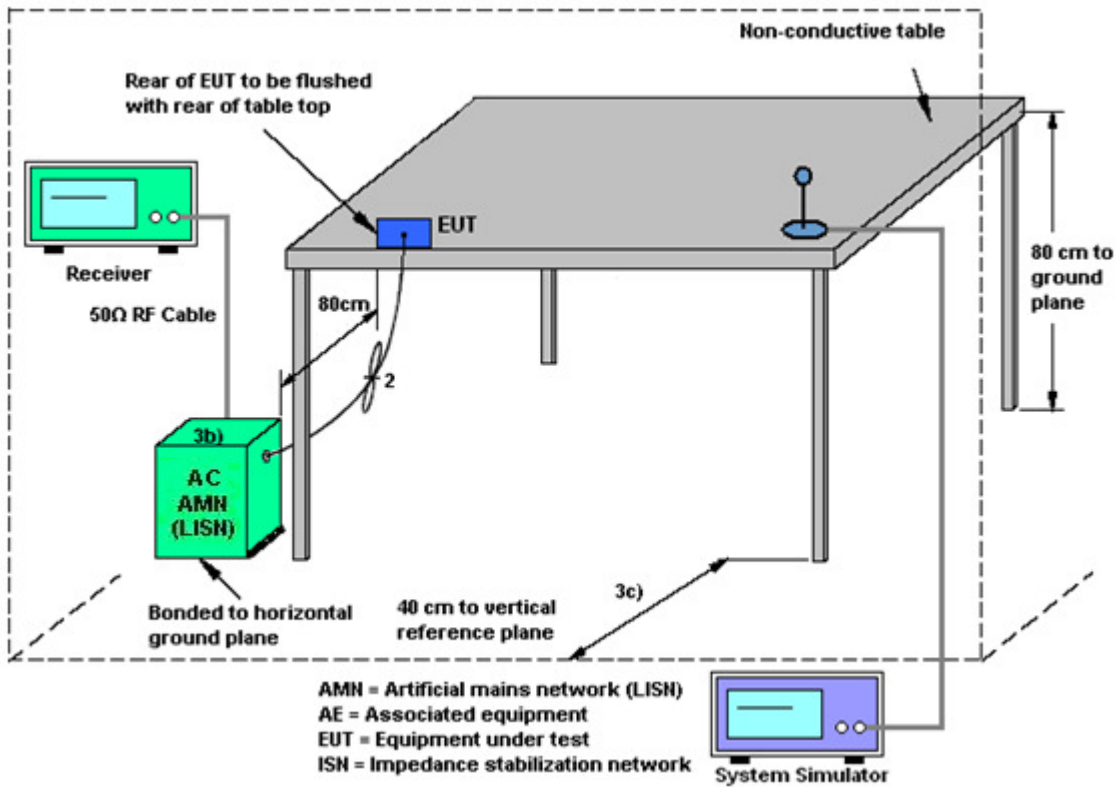

3.5.5 Test Result of AC Conducted Emission

Please refer to Appendix B.



3.6 Automatically Discontinue Transmission

3.6.1 Limit of Automatically Discontinue Transmission

The device shall automatically discontinue transmission in case of either absence of information to transmit or operational failure. These provisions are not intended to preclude the transmission of control or signaling information or the use of repetitive codes used by certain digital technologies to complete frame or burst intervals. Applicants shall include in their application for equipment authorization to describe how this requirement is met.

3.6.2 Measuring Instruments

The measuring equipment is listed in the section 4 of this test report.

3.6.3 Test Result of Automatically Discontinue Transmission

While the EUT is not transmitting any information, the EUT can automatically discontinue transmission and become standby mode for power saving. The EUT can detect the controlling signal of ACK message transmitting from remote device and verify whether it shall resend or discontinue transmission.



3.7 Antenna Requirements

3.7.1 Standard Applicable

If transmitting antenna directional gain is greater than 6 dBi, both the peak transmit power and the peak power spectral density shall be reduced by the amount in dB that the directional gain of the antenna exceeds 6 dBi.

3.7.2 Antenna Anti-Replacement Construction

An embedded-in antenna design is used.

3.7.3 Antenna Gain

The antenna peak gain of EUT is less than 6 dBi. Therefore, it is not necessary to reduce maximum peak output power limit.



4 List of Measuring Equipment

Instrument	Manufacturer	Model No.	Serial No.	Characteristics	Calibration Date	Test Date	Due Date	Remark
Power Meter	Anritsu	ML2495A	0932001	N/A	Sep. 26, 2017	Dec. 22, 2017~ Jan. 18, 2018	Sep. 25, 2018	Conducted (TH05-HY)
Power Sensor	Anritsu	MA2411B	0846202	300MHz~40GHz z	Sep. 26, 2017	Dec. 22, 2017~ Jan. 18, 2018	Sep. 25, 2018	Conducted (TH05-HY)
Spectrum Analyzer	Rohde & Schwarz	FSP30	101067	9kHz ~ 30GHz	Nov. 13, 2017	Dec. 22, 2017~ Jan. 18, 2018	Nov. 12, 2018	Conducted (TH05-HY)
AC Power Source	ChainTek	APC-1000W	N/A	N/A	N/A	Dec. 29, 2017	N/A	Conduction (CO05-HY)
EMI Test Receiver	Rohde & Schwarz	ESCI 7	100724	9kHz~7GHz	Sep. 20, 2017	Dec. 29, 2017	Sep. 19, 2018	Conduction (CO05-HY)
LISN	Rohde & Schwarz	ENV216	100080	9kHz~30MHz	Nov. 30, 2017	Dec. 29, 2017	Nov. 29, 2018	Conduction (CO05-HY)
Amplifier	MITEQ	TTA1840-35-HG	1871923	18GHz~40GHz, VSWR : 2.5:1 max	Jul. 18, 2017	Dec. 26, 2017~ Jan. 17, 2018	Jul. 17, 2018	Radiation (03CH11-HY)
Amplifier	SONOMA	310N	187312	9kHz~1GHz	Nov. 10, 2016	Dec. 26, 2017~ Jan. 17, 2018	Nov. 09, 2018	Radiation (03CH11-HY)
Bilog Antenna	TESEQ	CBL 6111D&N-6-0 6	35414&AT- N0602	30MHz~1GHz	Oct. 14, 2017	Dec. 26, 2017~ Jan. 17, 2018	Oct. 13, 2018	Radiation (03CH11-HY)
Horn Antenna	SCHWARZBE CK	BBHA 9120 D	9120D-132 6	1GHz ~ 18GHz	Oct. 16, 2017	Dec. 26, 2017~ Jan. 17, 2018	Oct. 15, 2018	Radiation (03CH11-HY)
Loop Antenna	Rohde & Schwarz	HFH2-Z2	100488	9 kHz~30 MHz	Nov. 23, 2017	Dec. 26, 2017~ Jan. 17, 2018	Nov. 22, 2019	Radiation (03CH11-HY)
Preamplifier	Keysight	83017A	MY532700 80	1GHz~26.5GHz	Nov. 10, 2016	Dec. 26, 2017~ Jan. 17, 2018	Nov. 09, 2018	Radiation (03CH11-HY)
Spectrum Analyzer	Keysight	N9010A	MY542004 86	10Hz ~ 44GHz	Oct. 19, 2017	Dec. 26, 2017~ Jan. 17, 2018	Oct. 18, 2018	Radiation (03CH11-HY)
Antenna Mast	EMEC	AM-BS-4500- B	N/A	1~4m	N/A	Dec. 26, 2017~ Jan. 17, 2018	N/A	Radiation (03CH11-HY)
Turn Table	EMEC	TT 2000	N/A	0~360 Degree	N/A	Dec. 26, 2017~ Jan. 17, 2018	N/A	Radiation (03CH11-HY)
SHF-EHF Horn Antenna	SCHWARZBE CK	BBHA 9170	BBHA9170 584	18GHz ~ 40GHz	Nov. 27, 2017	Dec. 26, 2017~ Jan. 17, 2018	Nov. 26, 2018	Radiation (03CH11-HY)
Preamplifier	Jet-Power	JPA0118-55-3 03	171000180 0054001	1GHz~18GHz	Dec. 07, 2017	Dec. 26, 2017~ Jan. 17, 2018	Dec. 06, 2018	Radiation (03CH11-HY)



5 Uncertainty of Evaluation

Uncertainty of Conducted Emission Measurement (150kHz ~ 30MHz)

Measuring Uncertainty for a Level of Confidence of 95% ($U = 2Uc(y)$)	2.70
---	------

Uncertainty of Radiated Emission Measurement (30 MHz ~ 1000 MHz)

Measuring Uncertainty for a Level of Confidence of 95% ($U = 2Uc(y)$)	5.20
---	------

Uncertainty of Radiated Emission Measurement (1000 MHz ~ 18000 MHz)

Measuring Uncertainty for a Level of Confidence of 95% ($U = 2Uc(y)$)	5.50
---	------

Uncertainty of Radiated Emission Measurement (18000 MHz ~ 40000 MHz)

Measuring Uncertainty for a Level of Confidence of 95% ($U = 2Uc(y)$)	5.20
---	------

Appendix A. Test Result of Conducted Test Items

Test Engineer:	Derek Hsu and Luffy Lin	Temperature:	21~25	°C
Test Date:	2017/12/22~2018/01/18	Relative Humidity:	51~54	%

TEST RESULTS DATA
26dB and 99% OBW

Band I										
Mod.	Data Rate	N _{TX}	CH.	Freq. (MHz)	99% Bandwidth (MHz)	26 dB Bandwidth (MHz)	IC 99% Bandwidth Power Limit (dBm)	IC 99% Bandwidth EIRP Limit (dBm)		
11a	6Mbps	1	36	5180	19.40	42.43	-	22.88		
11a	6Mbps	1	44	5220	18.70	41.47	-	22.72		
11a	6Mbps	1	48	5240	18.95	42.34	-	22.78		
HT20	MCS0	1	36	5180	18.90	24.80	-	22.76		
HT20	MCS0	1	44	5220	18.95	24.10	-	22.78		
HT20	MCS0	1	48	5240	18.90	24.45	-	22.76		
HT40	MCS0	1	38	5190	36.70	46.18	-	23.01		
HT40	MCS0	1	46	5230	36.60	45.72	-	23.01		

TEST RESULTS DATA
Average Power Table

FCC Band I										
Mod.	Data Rate	NTX	CH.	Freq. (MHz)	Duty Factor (dB)	Average Conducted Power (dBm)	FCC Conducted Power Limit (dBm)	DG (dBi)		Pass/Fail
11a	6Mbps	1	36	5180	0.64	15.90	24.00	-3.78		Pass
11a	6Mbps	1	44	5220	0.64	15.87	24.00	-3.78		Pass
11a	6Mbps	1	48	5240	0.64	15.97	24.00	-3.78		Pass
HT20	MCS0	1	36	5180	0.65	10.98	24.00	-3.78		Pass
HT20	MCS0	1	44	5220	0.65	10.95	24.00	-3.78		Pass
HT20	MCS0	1	48	5240	0.65	10.78	24.00	-3.78		Pass
HT40	MCS0	1	38	5190	0.52	9.57	24.00	-3.78		Pass
HT40	MCS0	1	46	5230	0.52	9.83	24.00	-3.78		Pass

TEST RESULTS DATA
Power Spectral Density

FCC Band I										
Mod.	Data Rate	N _{TX}	CH.	Freq. (MHz)	Duty Factor (dB)	Average Power Density (dBm/MHz)	Average PSD Limit (dBm/MHz)	DG (dBi)	-	Pass/Fail
11a	6Mbps	1	36	5180	0.64	3.70	11.00	-3.78		Pass
11a	6Mbps	1	44	5220	0.64	3.79	11.00	-3.78		Pass
11a	6Mbps	1	48	5240	0.64	4.22	11.00	-3.78		Pass
HT20	MCS0	1	36	5180	0.65	-1.67	11.00	-3.78		Pass
HT20	MCS0	1	44	5220	0.65	-1.50	11.00	-3.78		Pass
HT20	MCS0	1	48	5240	0.65	-1.66	11.00	-3.78		Pass
HT40	MCS0	1	38	5190	0.52	-5.54	11.00	-3.78		Pass
HT40	MCS0	1	46	5230	0.52	-5.48	11.00	-3.78		Pass

TEST RESULTS DATA
26dB and 99% OBW

Band II										
Mod.	Data Rate	N _{TX}	CH.	Freq. (MHz)	99% Bandwidth (MHz)	26 dB Bandwidth (MHz)	IC 99% Bandwidth Power Limit (dBm)	IC 99% Bandwidth EIRP Limit (dBm)	FCC 26dB Bandwidth Power Limit (dBm)	Note
11a	6M bps	1	52	5260	18.70	38.53	23.72	29.72	23.98	
11a	6M bps	1	60	5300	18.75	42.16	23.73	29.73	23.98	
11a	6M bps	1	64	5320	18.80	41.40	23.74	29.74	23.98	
HT20	MCS 0	1	52	5260	18.95	28.10	23.78	29.78	23.98	
HT20	MCS 0	1	60	5300	19.05	23.95	23.80	29.80	23.98	
HT20	MCS 0	1	64	5320	19.10	27.50	23.81	29.81	23.98	
HT40	MCS 0	1	54	5270	36.80	46.16	23.98	30.00	23.98	
HT40	MCS 0	1	62	5310	36.60	46.15	23.98	30.00	23.98	

TEST RESULTS DATA
Average Power Table

FCC Band II										
Mod.	Data Rate	N _{TX}	CH.	Freq. (MHz)	Duty Factor (dB)	Average Conducted Power (dBm)	FCC Conducted Power Limit (dBm)	DG (dBi)	EIRP Power Limit (dBm)	Pass/Fail
11a	6M bps	1	52	5260	0.64	15.81	23.98	-3.53	26.99	Pass
11a	6M bps	1	60	5300	0.64	15.92	23.98	-3.53	26.99	Pass
11a	6M bps	1	64	5320	0.64	15.97	23.98	-3.53	26.99	Pass
HT20	MCS 0	1	52	5260	0.65	10.83	23.98	-3.53	26.99	Pass
HT20	MCS 0	1	60	5300	0.65	10.95	23.98	-3.53	26.99	Pass
HT20	MCS 0	1	64	5320	0.65	10.97	23.98	-3.53	26.99	Pass
HT40	MCS 0	1	54	5270	0.52	9.76	23.98	-3.53	26.99	Pass
HT40	MCS 0	1	62	5310	0.52	9.91	23.98	-3.53	26.99	Pass

TEST RESULTS DATA
Power Spectral Density

Band II										
Mod.	Data Rate	N _{TX}	CH.	Freq. (MHz)	Duty Factor (dB)	Average Power Density (dBm/MHz)	Average PSD Limit (dBm/MHz)	DG (dBi)		Pass/Fail
11a	6M bps	1	52	5260	0.64	4.13	11.00	-3.53		Pass
11a	6M bps	1	60	5300	0.64	4.26	11.00	-3.53		Pass
11a	6M bps	1	64	5320	0.64	4.27	11.00	-3.53		Pass
HT20	MCS 0	1	52	5260	0.65	-1.43	11.00	-3.53		Pass
HT20	MCS 0	1	60	5300	0.65	-1.18	11.00	-3.53		Pass
HT20	MCS 0	1	64	5320	0.65	-1.03	11.00	-3.53		Pass
HT40	MCS 0	1	54	5270	0.52	-5.37	11.00	-3.53		Pass
HT40	MCS 0	1	62	5310	0.52	-5.11	11.00	-3.53		Pass

TEST RESULTS DATA
26dB and 99% OBW

Band III										
Mod.	Data Rate	N _{TX}	CH.	Freq. (MHz)	99% Bandwidth In UNII-2C (MHz)	26 dB Bandwidth In UNII-2C (MHz)	IC 99% Bandwidth Power Limit (dBm)	IC 99% Bandwidth EIRP Limit (dBm)	FCC 26dB Bandwidth Power Limit (dBm)	6dB Bandwidth for Straddle Channel (MHz)
11a	6M bps	1	100	5500	18.55	39.68	23.68	29.68	23.98	----
11a	6M bps	1	116	5580	18.50	38.80	23.67	29.67	23.98	----
11a	6M bps	1	140	5700	18.35	37.03	23.64	29.64	23.98	----
HT20	MCS 0	1	100	5500	19.00	24.50	23.79	29.79	23.98	----
HT20	MCS 0	1	116	5580	18.80	24.15	23.74	29.74	23.98	----
HT20	MCS 0	1	140	5700	18.95	25.20	23.78	29.78	23.98	----
HT40	MCS 0	1	102	5510	36.60	45.10	23.98	30.00	23.98	----
HT40	MCS 0	1	110	5550	36.70	46.51	23.98	30.00	23.98	----
HT40	MCS 0	1	134	5670	36.70	46.35	23.98	30.00	23.98	----

TEST RESULTS DATA
Average Power Table

FCC Band III										
Mod.	Data Rate	N _{TX}	CH.	Freq. (MHz)	Duty Factor (dB)	Average Conducted Power (dBm)	FCC Conducted Power Limit (dBm)	DG (dBi)	EIRP Power Limit (dBm)	Pass/Fail
11a	6M bps	1	100	5500	0.64	15.82	23.98	-3.97	26.99	Pass
11a	6M bps	1	116	5580	0.64	15.82	23.98	-3.97	26.99	Pass
11a	6M bps	1	140	5700	0.64	15.87	23.98	-3.97	26.99	Pass
HT20	MCS 0	1	100	5500	0.65	10.96	23.98	-3.97	26.99	Pass
HT20	MCS 0	1	116	5580	0.65	10.82	23.98	-3.97	26.99	Pass
HT20	MCS 0	1	140	5700	0.65	10.95	23.98	-3.97	26.99	Pass
HT40	MCS 0	1	102	5510	0.52	9.93	23.98	-3.97	26.99	Pass
HT40	MCS 0	1	110	5550	0.52	9.90	23.98	-3.97	26.99	Pass
HT40	MCS 0	1	134	5670	0.52	9.78	23.98	-3.97	26.99	Pass

TEST RESULTS DATA
Power Spectral Density

Band III										
Mod.	Data Rate	N _{TX}	CH.	Freq. (MHz)	Duty Factor (dB)	Average Power Density (dBm/MHz)	Average PSD Limit (dBm/MHz)	DG (dBi)		Pass/Fail
11a	6M bps	1	100	5500	0.64	4.81	11.00	-3.97		Pass
11a	6M bps	1	116	5580	0.64	4.98	11.00	-3.97		Pass
11a	6M bps	1	140	5700	0.64	2.21	11.00	-3.97		Pass
HT20	MCS 0	1	100	5500	0.65	-0.27	11.00	-3.97		Pass
HT20	MCS 0	1	116	5580	0.65	-0.39	11.00	-3.97		Pass
HT20	MCS 0	1	140	5700	0.65	-1.11	11.00	-3.97		Pass
HT40	MCS 0	1	102	5510	0.52	-3.97	11.00	-3.97		Pass
HT40	MCS 0	1	110	5550	0.52	-4.01	11.00	-3.97		Pass
HT40	MCS 0	1	134	5670	0.52	-4.21	11.00	-3.97		Pass



Appendix B. AC Conducted Emission Test Results

Test Engineer :	Blue Lan	Temperature :	24~26°C
		Relative Humidity :	63~65%

EUT Information

Report NO : 7D2018
 Test Mode : Mode 1
 Test Voltage : 120Vac/60Hz
 Phase : Line

ENV216 Auto Test FCC Power Bar - L

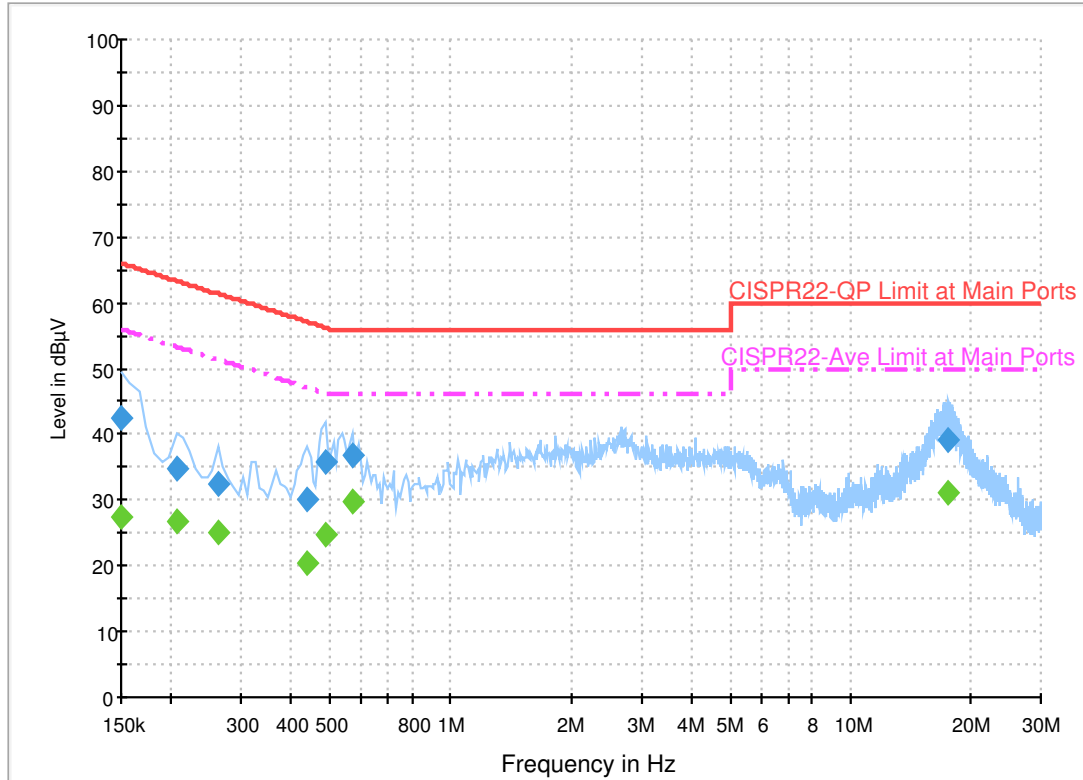

Final Result 1

Frequency (MHz)	QuasiPeak (dBµV)	Filter	Line	Corr. (dB)	Margin (dB)	Limit (dBµV)
0.150000	42.4	Off	L1	19.5	23.6	66.0
0.206000	34.7	Off	L1	19.5	28.7	63.4
0.262000	32.5	Off	L1	19.5	28.9	61.4
0.438000	30.0	Off	L1	19.5	27.1	57.1
0.486000	35.9	Off	L1	19.5	20.3	56.2
0.566000	36.7	Off	L1	19.5	19.3	56.0
17.654000	39.0	Off	L1	19.8	21.0	60.0

Final Result 2

Frequency (MHz)	Average (dBµV)	Filter	Line	Corr. (dB)	Margin (dB)	Limit (dBµV)
0.150000	27.5	Off	L1	19.5	28.5	56.0
0.206000	26.7	Off	L1	19.5	26.7	53.4
0.262000	25.2	Off	L1	19.5	26.2	51.4
0.438000	20.3	Off	L1	19.5	26.8	47.1
0.486000	24.7	Off	L1	19.5	21.5	46.2
0.566000	29.6	Off	L1	19.5	16.4	46.0
17.654000	31.0	Off	L1	19.8	19.0	50.0

EUT Information

Report NO : 7D2018
 Test Mode : Mode 1
 Test Voltage : 120Vac/60Hz
 Phase : Neutral

ENV216 Auto Test FCC Power Bar - N

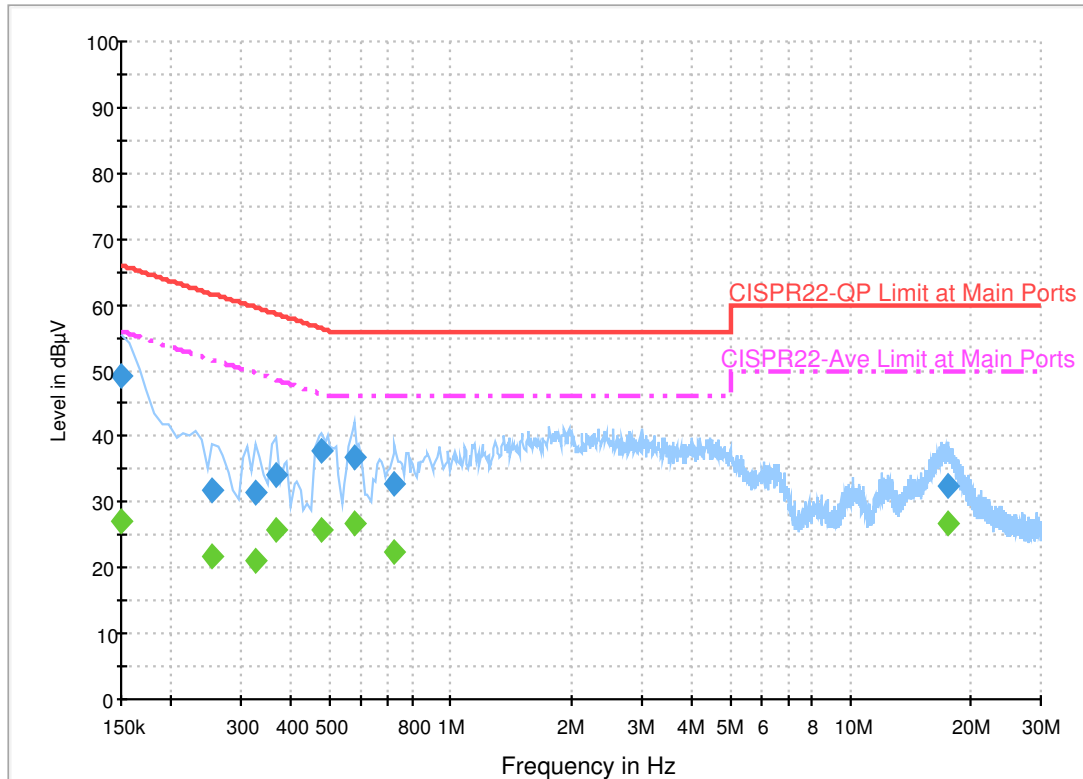

Final Result 1

Frequency (MHz)	QuasiPeak (dBµV)	Filter	Line	Corr. (dB)	Margin (dB)	Limit (dBµV)
0.150000	49.1	Off	N	19.5	16.9	66.0
0.254000	31.8	Off	N	19.5	29.8	61.6
0.326000	31.6	Off	N	19.5	28.0	59.6
0.366000	34.2	Off	N	19.5	24.4	58.6
0.478000	37.8	Off	N	19.5	18.6	56.4
0.574000	36.8	Off	N	19.5	19.2	56.0
0.726000	32.8	Off	N	19.5	23.2	56.0
17.454000	32.5	Off	N	19.8	27.5	60.0

Final Result 2

Frequency (MHz)	Average (dBµV)	Filter	Line	Corr. (dB)	Margin (dB)	Limit (dBµV)
0.150000	27.0	Off	N	19.5	29.0	56.0
0.254000	21.8	Off	N	19.5	29.8	51.6
0.326000	21.1	Off	N	19.5	28.5	49.6
0.366000	25.9	Off	N	19.5	22.7	48.6
0.478000	25.9	Off	N	19.5	20.5	46.4
0.574000	26.6	Off	N	19.5	19.4	46.0
0.726000	22.6	Off	N	19.5	23.4	46.0
17.454000	26.7	Off	N	19.8	23.3	50.0



Appendix C. Radiated Spurious Emission

Test Engineer :	Hao Hsu, Jacky Hung, and Ken Wu	Temperature :	23~26°C
		Relative Humidity :	50~55%

Band 1 - 5150~5250MHz

WIFI 802.11a (Band Edge @ 3m)

WIFI Ant.	Note	Frequency	Level	Over Limit	Limit Line	Read Level	Antenna Factor	Cable Loss	Preamp Factor	Ant Pos	Table Pos	Peak Avg.	Pol.	
1		(MHz)	(dBμV/m)	(dB)	(dBμV/m)	(dBμV)	(dB/m)	(dB)	(dB)	(cm)	(deg)	(P/A)	(H/V)	
802.11a CH 36 5180MHz		5150	57.44	-16.56	74	49.67	31.75	9.05	33.03	100	305	P	H	
		5149.76	49.56	-4.44	54	41.79	31.75	9.05	33.03	100	305	A	H	
	*	5180	110.52	-	-	102.7	31.78	9.07	33.03	100	305	P	H	
	*	5180	101.13	-	-	93.31	31.78	9.07	33.03	100	305	A	H	
													H	
			5148.98	50.74	-23.26	74	42.97	31.75	9.05	33.03	100	290	P	V
			5150	44.06	-9.94	54	36.29	31.75	9.05	33.03	100	290	A	V
	*		5180	103.41	-	-	95.59	31.78	9.07	33.03	100	290	P	V
	*		5180	94.39	-	-	86.57	31.78	9.07	33.03	100	290	A	V
														V
802.11a CH 44 5220MHz		5034.58	49.56	-24.44	74	42	31.63	8.97	33.04	108	287	P	H	
		5129.22	41.71	-12.29	54	33.98	31.73	9.03	33.03	108	287	A	H	
	*	5220	110.38	-	-	102.48	31.82	9.11	33.03	108	287	P	H	
	*	5220	101.22	-	-	93.32	31.82	9.11	33.03	108	287	A	H	
			5406.96	49.43	-24.57	74	41.23	32	9.22	33.02	108	287	P	H
			5408.4	41.09	-12.91	54	32.89	32	9.22	33.02	108	287	A	H
			5018.98	48.89	-25.11	74	41.36	31.62	8.95	33.04	389	142	P	V
			5022.36	40.5	-13.5	54	32.96	31.63	8.95	33.04	389	142	A	V
	*		5220	104.31	-	-	96.41	31.82	9.11	33.03	389	142	P	V
	*		5220	95.06	-	-	87.16	31.82	9.11	33.03	389	142	A	V
			5446.56	48.13	-25.87	74	39.81	32.05	9.29	33.02	389	142	P	V
			5456.16	39.54	-14.46	54	31.22	32.05	9.29	33.02	389	142	A	V



802.11a CH 48 5240MHz		5018.2	50.33	-23.67	74	42.8	31.62	8.95	33.04	103	304	P	H
		5150	42.27	-11.73	54	34.5	31.75	9.05	33.03	103	304	A	H
	*	5240	111.79	-	-	103.87	31.83	9.12	33.03	103	304	P	H
	*	5240	102.54	-	-	94.62	31.83	9.12	33.03	103	304	A	H
		5434.56	49.37	-24.63	74	41.1	32.03	9.26	33.02	103	304	P	H
		5436.96	41.99	-12.01	54	33.72	32.03	9.26	33.02	103	304	A	H
		5044.72	48.75	-25.25	74	41.17	31.65	8.97	33.04	104	291	P	V
		5050.96	40.74	-13.26	54	33.16	31.65	8.97	33.04	104	291	A	V
	*	5240	105.85	-	-	97.93	31.83	9.12	33.03	104	291	P	V
	*	5240	96.08	-	-	88.16	31.83	9.12	33.03	104	291	A	V
		5427.36	49.69	-24.31	74	41.43	32.02	9.26	33.02	104	291	P	V
		5433.36	40.33	-13.67	54	32.06	32.03	9.26	33.02	104	291	A	V
Remark	<ol style="list-style-type: none"> 1. No other spurious found. 2. All results are PASS against Peak and Average limit line. 												



Band 1 5150~5250MHz
WIFI 802.11a (Harmonic @ 3m)

WIFI Ant. 1	Note	Frequency (MHz)	Level (dBµV/m)	Over Limit (dB)	Limit Line (dBµV/m)	Read Level (dBµV)	Antenna Factor (dB/m)	Cable Loss (dB)	Preamp Factor (dB)	Ant Pos (cm)	Table Pos (deg)	Peak Avg. (P/A)	Pol. (H/V)
802.11a CH 36 5180MHz		10360	46.41	-27.59	74	57.16	39.51	14.63	65.2	100	0	P	H
		15540	45.71	-28.29	74	53.35	38	17.95	63.98	100	0	P	H
													H
													H
		10360	46.02	-27.98	74	56.77	39.51	14.63	65.2	100	0	P	V
		15540	45.31	-28.69	74	52.95	38	17.95	63.98	100	0	P	V
													V
													V
802.11a CH 44 5220MHz		10440	46.58	-27.42	74	57.18	39.61	14.68	65.2	100	0	P	H
		15660	44.05	-29.95	74	52.21	37.67	18.06	64.24	100	0	P	H
													H
													H
		10440	47.63	-26.37	74	58.23	39.61	14.68	65.2	100	0	P	V
		15660	44.67	-29.33	74	52.83	37.67	18.06	64.24	100	0	P	V
													V
													V
802.11a CH 48 5240MHz		10480	47.54	-26.46	74	58.03	39.68	14.72	65.2	100	0	P	H
		15720	44.75	-29.25	74	53.24	37.47	18.1	64.39	100	0	P	H
													H
													H
		10480	47.31	-26.69	74	57.8	39.68	14.72	65.2	100	0	P	V
		15720	45.04	-28.96	74	53.53	37.47	18.1	64.39	100	0	P	V
													V
													V
Remark	1. No other spurious found. 2. All results are PASS against Peak and Average limit line.												



Band 1 5150~5250MHz
WIFI 802.11n HT20 (Band Edge @ 3m)

WIFI Ant. 1	Note	Frequency (MHz)	Level (dBμV/m)	Over Limit (dB)	Limit Line (dBμV/m)	Read Level (dBμV)	Antenna Factor (dB/m)	Cable Loss (dB)	Preamp Factor (dB)	Ant Pos (cm)	Table Pos (deg)	Peak Avg. (P/A)	Pol. (H/V)	
802.11n HT20 CH 36 5180MHz		5149.76	52.67	-21.33	74	44.9	31.75	9.05	33.03	103	301	P	H	
		5127.66	43.67	-10.33	54	35.94	31.73	9.03	33.03	103	301	A	H	
	*	5180	104.69	-	-	96.87	31.78	9.07	33.03	103	301	P	H	
	*	5180	96.22	-	-	88.4	31.78	9.07	33.03	103	301	A	H	
													H	
													H	
			5126.1	49.4	-24.6	74	41.67	31.73	9.03	33.03	100	115	P	V
			5127.92	41.44	-12.56	54	33.71	31.73	9.03	33.03	100	115	A	V
		*	5180	99.77	-	-	91.95	31.78	9.07	33.03	100	115	P	V
		*	5180	90.94	-	-	83.12	31.78	9.07	33.03	100	115	A	V
													V	
													V	
802.11n HT20 CH 44 5220MHz		5126.36	49.36	-24.64	74	41.63	31.73	9.03	33.03	100	299	P	H	
		5120.12	40.69	-13.31	54	32.97	31.72	9.03	33.03	100	299	A	H	
		*	5220	103.14	-	-	95.24	31.82	9.11	33.03	100	299	P	H
		*	5220	94.86	-	-	86.96	31.82	9.11	33.03	100	299	A	H
			5404.32	48.26	-25.74	74	40.06	32	9.22	33.02	100	299	P	H
			5418.24	40.12	-13.88	54	31.9	32.02	9.22	33.02	100	299	A	H
			5115.7	49.4	-24.6	74	41.69	31.72	9.03	33.04	100	117	P	V
			5083.98	40.46	-13.54	54	32.81	31.68	9.01	33.04	100	117	A	V
		*	5220	97.95	-	-	90.05	31.82	9.11	33.03	100	117	P	V
		*	5220	89.39	-	-	81.49	31.82	9.11	33.03	100	117	A	V
		5370.96	47.69	-26.31	74	39.55	31.97	9.2	33.03	100	117	P	V	
		5452.8	39.8	-14.2	54	31.48	32.05	9.29	33.02	100	117	A	V	



802.11n HT20 CH 48 5240MHz		5108.42	49.05	-24.95	74	41.34	31.72	9.03	33.04	100	301	P	H
		5141.7	40.44	-13.56	54	32.67	31.75	9.05	33.03	100	301	A	H
	*	5240	102.76	-	-	94.84	31.83	9.12	33.03	100	301	P	H
	*	5240	94.69	-	-	86.77	31.83	9.12	33.03	100	301	A	H
		5439.84	49.15	-24.85	74	40.88	32.03	9.26	33.02	100	301	P	H
		5432.88	40.16	-13.84	54	31.89	32.03	9.26	33.02	100	301	A	H
		5125.58	49.07	-24.93	74	41.34	31.73	9.03	33.03	109	116	P	V
		5053.3	40.32	-13.68	54	32.74	31.65	8.97	33.04	109	116	A	V
	*	5240	96.81	-	-	88.89	31.83	9.12	33.03	109	116	P	V
	*	5240	88.63	-	-	80.71	31.83	9.12	33.03	109	116	A	V
		5402.4	48.43	-25.57	74	40.23	32	9.22	33.02	109	116	P	V
		5440.32	40.14	-13.86	54	31.87	32.03	9.26	33.02	109	116	A	V
Remark	<ol style="list-style-type: none"> No other spurious found. All results are PASS against Peak and Average limit line. 												



Band 1 5150~5250MHz
WIFI 802.11n HT20 (Harmonic @ 3m)

WIFI Ant. 1	Note	Frequency (MHz)	Level (dBμV/m)	Over Limit (dB)	Limit Line (dBμV/m)	Read Level (dBμV)	Antenna Factor (dB/m)	Cable Loss (dB)	Preamp Factor (dB)	Ant Pos (cm)	Table Pos (deg)	Peak Avg. (P/A)	Pol. (H/V)	
802.11n HT20 CH 36 5180MHz		10360	46.34	-27.66	74	52.7	39.51	14.63	60.81	100	0	P	H	
		15540	44.29	-29.71	74	48.72	38	17.95	60.77	100	0	P	H	
													H	
													H	
			10360	46.76	-27.24	74	53.12	39.51	14.63	60.81	100	0	P	V
			15540	44.39	-29.61	74	48.82	38	17.95	60.77	100	0	P	V
														V
802.11n HT20 CH 44 5220MHz		10440	46.49	-27.51	74	52.8	39.61	14.68	60.91	100	0	P	H	
		15660	43.92	-30.08	74	48.52	37.67	18.06	60.68	100	0	P	H	
													H	
													H	
			10440	46.89	-27.11	74	53.2	39.61	14.68	60.91	100	0	P	V
			15660	44.07	-29.93	74	48.67	37.67	18.06	60.68	100	0	P	V
														V
802.11n HT20 CH 48 5240MHz		10480	46.18	-27.82	74	52.45	39.68	14.72	60.98	100	0	P	H	
		15720	44.14	-29.86	74	48.86	37.47	18.1	60.62	100	0	P	H	
													H	
													H	
			10480	47.43	-26.57	74	53.7	39.68	14.72	60.98	100	0	P	V
			15720	43.04	-30.96	74	47.76	37.47	18.1	60.62	100	0	P	V
														V
Remark	1. No other spurious found.													
	2. All results are PASS against Peak and Average limit line.													



Band 1 5150~5250MHz
WIFI 802.11n HT40 (Band Edge @ 3m)

WIFI Ant. 1	Note	Frequency (MHz)	Level (dBμV/m)	Over Limit (dB)	Limit Line (dBμV/m)	Read Level (dBμV)	Antenna Factor (dB/m)	Cable Loss (dB)	Preamp Factor (dB)	Ant Pos (cm)	Table Pos (deg)	Peak Avg. (P/A)	Pol. (H/V)
802.11n HT40 CH 38 5190MHz		5149.24	56.33	-17.67	74	48.56	31.75	9.05	33.03	101	299	P	H
		5148.2	50.12	-3.88	54	42.35	31.75	9.05	33.03	101	299	A	H
	*	5190	98.9	-	-	91.06	31.78	9.09	33.03	101	299	P	H
	*	5190	91.51	-	-	83.67	31.78	9.09	33.03	101	299	A	H
		5377.96	48.36	-25.64	74	40.2	31.98	9.2	33.02	101	299	P	H
		5457.48	42.15	-11.85	54	33.83	32.05	9.29	33.02	101	299	A	H
		5141.18	51.04	-22.96	74	43.27	31.75	9.05	33.03	100	117	P	V
		5149.76	46.03	-7.97	54	38.26	31.75	9.05	33.03	100	117	A	V
	*	5190	94.18	-	-	86.34	31.78	9.09	33.03	100	117	P	V
	*	5190	85.88	-	-	78.04	31.78	9.09	33.03	100	117	A	V
		5390.84	48.32	-25.68	74	40.16	31.98	9.2	33.02	100	117	P	V
		5457.2	41.6	-12.4	54	33.28	32.05	9.29	33.02	100	117	A	V
	802.11n HT40 CH 46 5230MHz		5051.48	49.82	-24.18	74	42.24	31.65	8.97	33.04	100	300	P
		5074.1	43.03	-10.97	54	35.4	31.68	8.99	33.04	100	300	A	H
*		5230	99.67	-	-	91.76	31.83	9.11	33.03	100	300	P	H
*		5230	91.92	-	-	84.01	31.83	9.11	33.03	100	300	A	H
		5427.84	48.53	-25.47	74	40.27	32.02	9.26	33.02	100	300	P	H
		5433.12	41.86	-12.14	54	33.59	32.03	9.26	33.02	100	300	A	H
		5112.06	49.58	-24.42	74	41.87	31.72	9.03	33.04	100	116	P	V
		5073.32	42.5	-11.5	54	34.87	31.68	8.99	33.04	100	116	A	V
*		5230	93.79	-	-	85.88	31.83	9.11	33.03	100	116	P	V
*		5230	86.51	-	-	78.6	31.83	9.11	33.03	100	116	A	V
	5413.92	47.9	-26.1	74	39.68	32.02	9.22	33.02	100	116	P	V	
	5440.08	42.18	-11.82	54	33.91	32.03	9.26	33.02	100	116	A	V	
Remark	1. No other spurious found. 2. All results are PASS against Peak and Average limit line.												



Band 1 5150~5250MHz
WIFI 802.11n HT40 (Harmonic @ 3m)

WIFI Ant. 1	Note	Frequency (MHz)	Level (dBμV/m)	Over Limit (dB)	Limit Line (dBμV/m)	Read Level (dBμV)	Antenna Factor (dB/m)	Cable Loss (dB)	Preamp Factor (dB)	Ant Pos (cm)	Table Pos (deg)	Peak Avg. (P/A)	Pol. (H/V)
802.11n HT40 CH 38 5190MHz		10380	45.7	-28.3	74	52.05	39.54	14.64	60.84	100	0	P	H
		15570	44.4	-29.6	74	48.87	37.91	17.98	60.74	100	0	P	H
													H
													H
		10380	46.18	-27.82	74	52.53	39.54	14.64	60.84	100	0	P	V
		15570	43.53	-30.47	74	48	37.91	17.98	60.74	100	0	P	V
													V
													V
802.11n HT40 CH 46 5230MHz		10460	46.33	-27.67	74	52.63	39.63	14.69	60.93	100	0	P	H
		15690	43.76	-30.24	74	48.43	37.57	18.07	60.65	100	0	P	H
													H
													H
		10460	46.38	-27.62	74	52.68	39.63	14.69	60.93	100	0	P	V
		15690	43.34	-30.66	74	48.01	37.57	18.07	60.65	100	0	P	V
													V
													V
Remark	1. No other spurious found. 2. All results are PASS against Peak and Average limit line.												



Band 2 - 5250~5350MHz
WIFI 802.11a (Band Edge @ 3m)

WIFI	Note	Frequency	Level	Over	Limit	Read	Antenna	Cable	Preamp	Ant	Table	Peak	Pol.
Ant.				Limit	Line	Level	Factor	Loss	Factor	Pos	Pos	Avg.	
1		(MHz)	(dBμV/m)	(dB)	(dBμV/m)	(dBμV)	(dB/m)	(dB)	(dB)	(cm)	(deg)	(P/A)	(H/V)
802.11a CH 52 5260MHz		5133.62	48.67	-25.33	74	40.92	31.73	9.05	33.03	100	304	P	H
		5072.42	41.8	-12.2	54	34.17	31.68	8.99	33.04	100	304	A	H
	*	5260	110.99	-	-	103.03	31.87	9.12	33.03	100	304	P	H
	*	5260	101.57	-	-	93.61	31.87	9.12	33.03	100	304	A	H
		5448.96	49.28	-24.72	74	40.96	32.05	9.29	33.02	100	304	P	H
		5459.04	41.35	-12.65	54	33.03	32.05	9.29	33.02	100	304	A	H
		5108.8	48.94	-25.06	74	41.23	31.72	9.03	33.04	100	291	P	V
		5060.18	40.86	-13.14	54	33.24	31.67	8.99	33.04	100	291	A	V
	*	5260	104.42	-	-	96.46	31.87	9.12	33.03	100	291	P	V
	*	5260	95.31	-	-	87.35	31.87	9.12	33.03	100	291	A	V
		5446.56	47.99	-26.01	74	39.67	32.05	9.29	33.02	100	291	P	V
		5457.12	40.4	-13.6	54	32.08	32.05	9.29	33.02	100	291	A	V
802.11a CH 60 5300MHz		5092.48	48.99	-25.01	74	41.32	31.7	9.01	33.04	100	302	P	H
		5102	41.54	-12.46	54	33.87	31.7	9.01	33.04	100	302	A	H
	*	5300	109.79	-	-	101.76	31.9	9.16	33.03	100	302	P	H
	*	5300	100.94	-	-	92.91	31.9	9.16	33.03	100	302	A	H
		5352.48	51.48	-22.52	74	43.37	31.95	9.19	33.03	100	302	P	H
		5352	45.86	-8.14	54	37.75	31.95	9.19	33.03	100	302	A	H
		5038.42	49.64	-24.36	74	42.06	31.65	8.97	33.04	400	143	P	V
		5106.42	40.58	-13.42	54	32.89	31.72	9.01	33.04	400	143	A	V
	*	5300	105.42	-	-	97.39	31.9	9.16	33.03	400	143	P	V
	*	5300	95.41	-	-	87.38	31.9	9.16	33.03	400	143	A	V
		5352.24	48.75	-25.25	74	40.64	31.95	9.19	33.03	400	143	P	V
		5352.24	40.97	-13.03	54	32.86	31.95	9.19	33.03	400	143	A	V



802.11a CH 64 5320MHz	*	5320	110.46	-	-	102.4	31.92	9.17	33.03	100	304	P	H
	*	5320	100.91	-	-	92.85	31.92	9.17	33.03	100	304	A	H
		5353.44	57.86	-16.14	74	49.75	31.95	9.19	33.03	100	304	P	H
		5350.08	49.44	-4.56	54	41.33	31.95	9.19	33.03	100	304	A	H
													H
													H
	*	5320	104.6	-	-	96.54	31.92	9.17	33.03	103	290	P	V
	*	5320	95.09	-	-	87.03	31.92	9.17	33.03	103	290	A	V
		5354.08	55.62	-18.38	74	47.51	31.95	9.19	33.03	103	290	P	V
		5350.88	44.55	-9.45	54	36.44	31.95	9.19	33.03	103	290	A	V
													V
													V
Remark	1. No other spurious found. 2. All results are PASS against Peak and Average limit line.												



Band 2 5250~5350MHz

WIFI 802.11a (Harmonic @ 3m)

WIFI Ant. 1	Note	Frequency (MHz)	Level (dBμV/m)	Over Limit (dB)	Limit Line (dBμV/m)	Read Level (dBμV)	Antenna Factor (dB/m)	Cable Loss (dB)	Preamp Factor (dB)	Ant Pos (cm)	Table Pos (deg)	Peak Avg. (P/A)	Pol. (H/V)
802.11a CH 52 5260MHz		10520	47.75	-26.25	74	58.19	39.71	14.74	65.2	100	0	P	H
		15780	44.77	-29.23	74	53.49	37.33	18.15	64.51	100	0	P	H
													H
													H
		10520	46.93	-27.07	74	57.37	39.71	14.74	65.2	100	0	P	V
		15780	44.18	-29.82	74	52.9	37.33	18.15	64.51	100	0	P	V
													V
													V
802.11a CH 60 5300MHz		10600	46.91	-27.09	74	57.2	39.78	14.8	65.18	100	0	P	H
		15900	43	-31	74	52.25	36.99	18.25	64.77	100	0	P	H
													H
													H
		10600	47.81	-26.19	74	58.1	39.78	14.8	65.18	100	0	P	V
		15900	43.14	-30.86	74	52.39	36.99	18.25	64.77	100	0	P	V
													V
													V
802.11a CH 64 5320MHz		10640	45.65	-28.35	74	55.89	39.81	14.82	65.17	100	0	P	H
		15960	43.48	-30.52	74	53.04	36.8	18.3	64.92	100	0	P	H
													H
													H
		10640	45.99	-28.01	74	56.23	39.81	14.82	65.17	100	0	P	V
		15960	43.49	-30.51	74	53.05	36.8	18.3	64.92	100	0	P	V
													V
													V
Remark	1. No other spurious found. 2. All results are PASS against Peak and Average limit line.												



Band 2 5250~5350MHz
WIFI 802.11n HT20 (Band Edge @ 3m)

WIFI Ant. 1	Note	Frequency (MHz)	Level (dBμV/m)	Over Limit (dB)	Limit Line (dBμV/m)	Read Level (dBμV)	Antenna Factor (dB/m)	Cable Loss (dB)	Preamp Factor (dB)	Ant Pos (cm)	Table Pos (deg)	Peak Avg. (P/A)	Pol. (H/V)
802.11n HT20 CH 52 5260MHz		5120.9	49.78	-24.22	74	42.06	31.72	9.03	33.03	100	297	P	H
		5041.86	40.44	-13.56	54	32.86	31.65	8.97	33.04	100	297	A	H
	*	5260	103.24	-	-	95.28	31.87	9.12	33.03	100	297	P	H
	*	5260	94.75	-	-	86.79	31.87	9.12	33.03	100	297	A	H
		5454	47.91	-26.09	74	39.59	32.05	9.29	33.02	100	297	P	H
		5449.92	40.21	-13.79	54	31.89	32.05	9.29	33.02	100	297	A	H
		5104.78	49.26	-24.74	74	41.59	31.7	9.01	33.04	106	115	P	V
		5047.06	40.27	-13.73	54	32.69	31.65	8.97	33.04	106	115	A	V
	*	5260	96.92	-	-	88.96	31.87	9.12	33.03	106	115	P	V
	*	5260	88.57	-	-	80.61	31.87	9.12	33.03	106	115	A	V
		5406	48.37	-25.63	74	40.17	32	9.22	33.02	106	115	P	V
		5444.4	39.82	-14.18	54	31.55	32.03	9.26	33.02	106	115	A	V
802.11n HT20 CH 60 5300MHz		5136	50.93	-23.07	74	43.18	31.73	9.05	33.03	100	297	P	H
		5053.04	40.56	-13.44	54	32.98	31.65	8.97	33.04	100	297	A	H
	*	5300	102.74	-	-	94.71	31.9	9.16	33.03	100	297	P	H
	*	5300	94.73	-	-	86.7	31.9	9.16	33.03	100	297	A	H
		5351.76	49.36	-24.64	74	41.25	31.95	9.19	33.03	100	297	P	H
		5351.76	42.85	-11.15	54	34.74	31.95	9.19	33.03	100	297	A	H
		5041.48	50.61	-23.39	74	43.03	31.65	8.97	33.04	108	115	P	V
		5043.52	40.32	-13.68	54	32.74	31.65	8.97	33.04	108	115	A	V
	*	5300	97.06	-	-	89.03	31.9	9.16	33.03	108	115	P	V
	*	5300	88.97	-	-	80.94	31.9	9.16	33.03	108	115	A	V
	5410.8	47.46	-26.54	74	39.26	32	9.22	33.02	108	115	P	V	
	5352	40.19	-13.81	54	32.08	31.95	9.19	33.03	108	115	A	V	



802.11n HT20 CH 64 5320MHz	*	5320	102.47	-	-	94.41	31.92	9.17	33.03	109	296	P	H
	*	5320	94.32	-	-	86.26	31.92	9.17	33.03	109	296	A	H
		5350.72	51.32	-22.68	74	43.21	31.95	9.19	33.03	109	296	P	H
		5371.84	42.71	-11.29	54	34.57	31.97	9.2	33.03	109	296	A	H
													H
													H
	*	5320	96.81	-	-	88.75	31.92	9.17	33.03	103	114	P	V
	*	5320	88.49	-	-	80.43	31.92	9.17	33.03	103	114	A	V
		5446.88	48.64	-25.36	74	40.32	32.05	9.29	33.02	103	114	P	V
		5371.52	40.64	-13.36	54	32.5	31.97	9.2	33.03	103	114	A	V
													V
													V
Remark	1. No other spurious found. 2. All results are PASS against Peak and Average limit line.												



Band 2 5250~5350MHz
WIFI 802.11n HT20 (Harmonic @ 3m)

WIFI Ant. 1	Note	Frequency (MHz)	Level (dBμV/m)	Over Limit (dB)	Limit Line (dBμV/m)	Read Level (dBμV)	Antenna Factor (dB/m)	Cable Loss (dB)	Preamp Factor (dB)	Ant Pos (cm)	Table Pos (deg)	Peak Avg. (P/A)	Pol. (H/V)
802.11n HT20 CH 52 5260MHz		10520	46.65	-27.35	74	52.91	39.71	14.74	61.02	100	0	P	H
		15780	43.57	-30.43	74	48.36	37.33	18.15	60.58	100	0	P	H
													H
													H
		10520	46.51	-27.49	74	52.77	39.71	14.74	61.02	100	0	P	V
		15780	43.88	-30.12	74	48.67	37.33	18.15	60.58	100	0	P	V
													V
802.11n HT20 CH 60 5300MHz		10600	46.7	-27.3	74	52.91	39.78	14.8	61.1	100	0	P	H
		15900	42.49	-31.51	74	47.45	36.99	18.25	60.48	100	0	P	H
													H
													H
		10600	45.56	-28.44	74	51.77	39.78	14.8	61.1	100	0	P	V
		15900	43.3	-30.7	74	48.26	36.99	18.25	60.48	100	0	P	V
													V
802.11n HT20 CH 64 5320MHz		10640	45.38	-28.62	74	51.59	39.81	14.82	61.14	100	0	P	H
		15960	42.65	-31.35	74	47.72	36.8	18.3	60.43	100	0	P	H
													H
													H
		10640	46.07	-27.93	74	52.28	39.81	14.82	61.14	100	0	P	V
		15960	42.83	-31.17	74	47.9	36.8	18.3	60.43	100	0	P	V
													V
Remark	1. No other spurious found.												
	2. All results are PASS against Peak and Average limit line.												



Band 2 5250~5350MHz
WIFI 802.11n HT40 (Band Edge @ 3m)

WIFI Ant. 1	Note	Frequency (MHz)	Level (dBμV/m)	Over Limit (dB)	Limit Line (dBμV/m)	Read Level (dBμV)	Antenna Factor (dB/m)	Cable Loss (dB)	Preamp Factor (dB)	Ant Pos (cm)	Table Pos (deg)	Peak Avg. (P/A)	Pol. (H/V)
802.11n HT40 CH 54 5270MHz		5050.32	48.91	-25.09	74	41.33	31.65	8.97	33.04	105	298	P	H
		5066.3	42.63	-11.37	54	35.01	31.67	8.99	33.04	105	298	A	H
	*	5270	98.79	-	-	90.81	31.87	9.14	33.03	105	298	P	H
	*	5270	91.78	-	-	83.8	31.87	9.14	33.03	105	298	A	H
		5451.6	48.16	-25.84	74	39.84	32.05	9.29	33.02	105	298	P	H
		5439.12	42.02	-11.98	54	33.75	32.03	9.26	33.02	105	298	A	H
		5032.64	49.74	-24.26	74	42.18	31.63	8.97	33.04	100	116	P	V
		5100.98	42.57	-11.43	54	34.9	31.7	9.01	33.04	100	116	A	V
	*	5270	92.3	-	-	84.32	31.87	9.14	33.03	100	116	P	V
	*	5270	85.34	-	-	77.36	31.87	9.14	33.03	100	116	A	V
		5408.64	48.22	-25.78	74	40.02	32	9.22	33.02	100	116	P	V
		5447.04	41.93	-12.07	54	33.61	32.05	9.29	33.02	100	116	A	V
802.11n HT40 CH 62 5310MHz		5107.1	49.21	-24.79	74	41.52	31.72	9.01	33.04	100	297	P	H
		5084.66	42.48	-11.52	54	34.83	31.68	9.01	33.04	100	297	A	H
	*	5310	99.17	-	-	91.12	31.92	9.16	33.03	100	297	P	H
	*	5310	91.68	-	-	83.63	31.92	9.16	33.03	100	297	A	H
		5351.76	55.25	-18.75	74	47.14	31.95	9.19	33.03	100	297	P	H
		5350.08	50.29	-3.71	54	42.18	31.95	9.19	33.03	100	297	A	H
		5081.26	49.35	-24.65	74	41.7	31.68	9.01	33.04	110	115	P	V
		5029.24	42.75	-11.25	54	35.19	31.63	8.97	33.04	110	115	A	V
	*	5310	92.69	-	-	84.64	31.92	9.16	33.03	110	115	P	V
	*	5310	85.24	-	-	77.19	31.92	9.16	33.03	110	115	A	V
	5356.32	50.76	-23.24	74	42.65	31.95	9.19	33.03	110	115	P	V	
	5350.32	44.69	-9.31	54	36.58	31.95	9.19	33.03	110	115	A	V	
Remark	1. No other spurious found. 2. All results are PASS against Peak and Average limit line.												



Band 2 5250~5350MHz
WIFI 802.11n HT40 (Harmonic @ 3m)

WIFI Ant. 1	Note	Frequency (MHz)	Level (dBμV/m)	Over Limit (dB)	Limit Line (dBμV/m)	Read Level (dBμV)	Antenna Factor (dB/m)	Cable Loss (dB)	Preamp Factor (dB)	Ant Pos (cm)	Table Pos (deg)	Peak Avg. (P/A)	Pol. (H/V)
802.11n HT40 CH 54 5270MHz		10540	46.21	-27.79	74	52.44	39.73	14.76	61.03	100	0	P	H
		15810	43.76	-30.24	74	48.59	37.23	18.18	60.55	100	0	P	H
													H
													H
		10540	46.15	-27.85	74	52.38	39.73	14.76	61.03	100	0	P	V
		15810	44.48	-29.52	74	49.31	37.23	18.18	60.55	100	0	P	V
													V
													V
802.11n HT40 CH 62 5310MHz		10620	45.01	-28.99	74	51.22	39.8	14.81	61.12	100	0	P	H
		15930	43.15	-30.85	74	48.17	36.89	18.28	60.46	100	0	P	H
													H
													H
		10620	46.38	-27.62	74	52.59	39.8	14.81	61.12	100	0	P	V
		15930	43.52	-30.48	74	48.54	36.89	18.28	60.46	100	0	P	V
													V
													V
Remark	1. No other spurious found. 2. All results are PASS against Peak and Average limit line.												



Band 3 - 5470~5725MHz
WIFI 802.11a (Band Edge @ 3m)

WIFI	Note	Frequency	Level	Over	Limit	Read	Antenna	Cable	Preamp	Ant	Table	Peak	Pol.	
Ant.				Limit	Line	Level	Factor	Loss	Factor	Pos	Pos	Avg.		
1		(MHz)	(dBμV/m)	(dB)	(dBμV/m)	(dBμV)	(dB/m)	(dB)	(dB)	(cm)	(deg)	(P/A)	(H/V)	
802.11a CH 100 5500MHz		5447.28	53.22	-20.78	74	44.9	32.05	9.29	33.02	100	289	P	H	
		5467.92	55.72	-12.48	68.2	47.38	32.07	9.29	33.02	100	289	P	H	
		5447.76	45.61	-8.39	54	37.29	32.05	9.29	33.02	100	289	A	H	
	*	5500	108.56	-	-	100.11	32.1	9.37	33.02	100	289	P	H	
	*	5500	100.03	-	-	91.58	32.1	9.37	33.02	100	289	A	H	
														H
			5458.96	52.16	-21.84	74	43.84	32.05	9.29	33.02	387	172	P	V
			5466.48	55.98	-12.22	68.2	47.64	32.07	9.29	33.02	387	172	P	V
			5447.44	43.53	-10.47	54	35.21	32.05	9.29	33.02	387	172	A	V
	*		5500	106.23	-	-	97.78	32.1	9.37	33.02	387	172	P	V
	*		5500	97.18	-	-	88.73	32.1	9.37	33.02	387	172	A	V
														V
802.11a CH 116 5580MHz		5394.64	49.21	-24.79	74	41.01	32	9.22	33.02	100	290	P	H	
		5465.68	48.68	-19.52	68.2	40.34	32.07	9.29	33.02	100	290	P	H	
		5394.88	40.88	-13.12	54	32.68	32	9.22	33.02	100	290	A	H	
	*	5580	109.09	-	-	100.46	32.22	9.48	33.07	100	290	P	H	
	*	5580	100.16	-	-	91.53	32.22	9.48	33.07	100	290	A	H	
			5759.015	49.53	-18.67	68.2	40.17	32.57	9.95	33.16	100	290	P	H
			5440.48	48.53	-25.47	74	40.26	32.03	9.26	33.02	394	175	P	V
			5468.56	47.81	-20.39	68.2	39.47	32.07	9.29	33.02	394	175	P	V
			5459.44	39.71	-14.29	54	31.39	32.05	9.29	33.02	394	175	A	V
	*		5580	107.48	-	-	98.85	32.22	9.48	33.07	394	175	P	V
	*		5580	98.16	-	-	89.53	32.22	9.48	33.07	394	175	A	V
			5765	50.69	-17.51	68.2	41.33	32.57	9.95	33.16	394	175	P	V



802.11a CH 140 5700MHz	*	5700	107.45	-	-	98.38	32.44	9.75	33.12	100	299	P	H
	*	5700	98.09	-	-	89.02	32.44	9.75	33.12	100	299	A	H
		5727.64	58.49	-9.71	68.2	49.31	32.5	9.81	33.13	100	299	P	H
													H
													H
													H
	*	5700	106.54	-	-	97.47	32.44	9.75	33.12	398	1	P	V
	*	5700	97.51	-	-	88.44	32.44	9.75	33.12	398	1	A	V
		5725.4	57.61	-10.59	68.2	48.43	32.5	9.81	33.13	398	1	P	V
													V
													V
													V
Remark	1. No other spurious found. 2. All results are PASS against Peak and Average limit line.												



Band 3 - 5470~5725MHz
WIFI 802.11a (Harmonic @ 3m)

WIFI Ant. 1	Note	Frequency (MHz)	Level (dBμV/m)	Over Limit (dB)	Limit Line (dBμV/m)	Read Level (dBμV)	Antenna Factor (dB/m)	Cable Loss (dB)	Preamp Factor (dB)	Ant Pos (cm)	Table Pos (deg)	Peak Avg. (P/A)	Pol. (H/V)
802.11a CH 100 5500MHz		11000	47.45	-26.55	74	57.07	40.1	15.08	65.1	100	0	P	H
		16500	44.79	-23.41	68.2	52.35	38.5	18.74	65.1	100	0	P	H
													H
													H
		11000	48.64	-25.36	74	58.26	40.1	15.08	65.1	100	0	P	V
		16500	45.46	-22.74	68.2	53.02	38.5	18.74	65.1	100	0	P	V
													V
													V
802.11a CH 116 5580MHz		11160	47.41	-26.59	74	57.05	40.07	15.2	65.2	100	0	P	H
		16740	46.24	-21.96	68.2	52.77	39.08	18.93	64.86	100	0	P	H
													H
													H
		11160	49.05	-24.95	74	58.69	40.07	15.2	65.2	100	0	P	V
		16740	44.9	-23.3	68.2	51.43	39.08	18.93	64.86	100	0	P	V
													V
													V
802.11a CH 140 5700MHz		11400	47.49	-26.51	74	57.15	40.02	15.38	65.34	100	0	P	H
		17100	48.63	-19.57	68.2	53.5	40.06	19.18	64.46	100	0	P	H
													H
													H
		11400	48.16	-25.84	74	57.82	40.02	15.38	65.34	100	0	P	V
		17100	48.95	-19.25	68.2	53.82	40.06	19.18	64.46	100	0	P	V
													V
													V
Remark	1. No other spurious found. 2. All results are PASS against Peak and Average limit line.												



Band 3 - 5470~5725MHz
WIFI 802.11n HT20 (Band Edge @ 3m)

WIFI Ant. 1	Note	Frequency (MHz)	Level (dBμV/m)	Over Limit (dB)	Limit Line (dBμV/m)	Read Level (dBμV)	Antenna Factor (dB/m)	Cable Loss (dB)	Preamp Factor (dB)	Ant Pos (cm)	Table Pos (deg)	Peak Avg. (P/A)	Pol. (H/V)	
802.11n HT20 CH 100 5500MHz		5433.36	48.92	-25.08	74	40.65	32.03	9.26	33.02	100	263	P	H	
		5448.56	42.09	-11.91	54	33.77	32.05	9.29	33.02	100	263	A	H	
	*	5500	100.6	-	-	92.15	32.1	9.37	33.02	100	263	P	H	
	*	5500	92.51	-	-	84.06	32.1	9.37	33.02	100	263	A	H	
													H	
														H
			5469.84	48.28	-25.72	74	39.94	32.07	9.29	33.02	100	302	P	V
			5448.24	40.37	-13.63	54	32.05	32.05	9.29	33.02	100	302	A	V
		*	5500	96.37	-	-	87.92	32.1	9.37	33.02	100	302	P	V
		*	5500	87.98	-	-	79.53	32.1	9.37	33.02	100	302	A	V
													V	
													V	
802.11n HT20 CH 116 5580MHz		5364.64	47.54	-26.46	74	39.41	31.97	9.19	33.03	101	118	P	H	
		5460.64	39.97	-14.03	54	31.65	32.05	9.29	33.02	101	118	A	H	
	*	5580	101	-	-	92.37	32.22	9.48	33.07	101	118	P	H	
	*	5580	92.81	-	-	84.18	32.22	9.48	33.07	101	118	A	H	
			5729.72	49.68	-24.32	74	40.5	32.5	9.81	33.13	101	118	P	H
			5763.425	41.03	-12.97	54	31.67	32.57	9.95	33.16	101	118	A	H
			5457.52	49.23	-24.77	74	40.91	32.05	9.29	33.02	100	302	P	V
			5453.68	39.98	-14.02	54	31.66	32.05	9.29	33.02	100	302	A	V
		*	5580	96.12	-	-	87.49	32.22	9.48	33.07	100	302	P	V
		*	5580	87.96	-	-	79.33	32.22	9.48	33.07	100	302	A	V
		5751.77	49.53	-24.47	74	40.23	32.57	9.88	33.15	100	302	P	V	
		5728.145	40.83	-13.17	54	31.65	32.5	9.81	33.13	100	302	A	V	



802.11n HT20 CH 140 5700MHz	*	5700	101.62	-	-	92.55	32.44	9.75	33.12	100	340	P	H
	*	5700	93.88	-	-	84.81	32.44	9.75	33.12	100	340	A	H
		5725	53.49	-20.51	74	44.31	32.5	9.81	33.13	100	340	P	H
		5725.08	45.84	-8.16	54	36.66	32.5	9.81	33.13	100	340	A	H
													H
													H
	*	5700	97.32	-	-	88.25	32.44	9.75	33.12	100	89	P	V
	*	5700	89.11	-	-	80.04	32.44	9.75	33.12	100	89	A	V
		5753.64	50.33	-23.67	74	41.03	32.57	9.88	33.15	100	89	P	V
		5725	43	-11	54	33.82	32.5	9.81	33.13	100	89	A	V
													V
													V
Remark	1. No other spurious found. 2. All results are PASS against Peak and Average limit line.												



Band 3 - 5470~5725MHz
WIFI 802.11n HT20 (Harmonic @ 3m)

WIFI Ant. 1	Note	Frequency (MHz)	Level (dBμV/m)	Over Limit (dB)	Limit Line (dBμV/m)	Read Level (dBμV)	Antenna Factor (dB/m)	Cable Loss (dB)	Preamp Factor (dB)	Ant Pos (cm)	Table Pos (deg)	Peak Avg. (P/A)	Pol. (H/V)	
802.11n HT20 CH 100 5500MHz		11000	47.64	-26.36	74	53.66	40.1	15.08	61.5	100	0	P	H	
		16500	44.9	-29.1	74	47.06	38.5	18.74	59.7	100	0	P	H	
													H	
													H	
			11000	46.95	-27.05	74	52.97	40.1	15.08	61.5	100	0	P	V
			16500	44.65	-29.35	74	46.81	38.5	18.74	59.7	100	0	P	V
														V
802.11n HT20 CH 116 5580MHz		11160	46.6	-27.4	74	52.51	40.07	15.2	61.47	100	0	P	H	
		16740	46.15	-27.85	74	46.89	39.08	18.93	59.07	100	0	P	H	
													H	
													H	
			11160	46.54	-27.46	74	52.45	40.07	15.2	61.47	100	0	P	V
			16740	47.04	-26.96	74	47.78	39.08	18.93	59.07	100	0	P	V
														V
802.11n HT20 CH 140 5700MHz		11400	46.14	-27.86	74	51.88	40.02	15.38	61.42	100	0	P	H	
		17100	47.33	-26.67	74	45.88	40.06	19.18	58.14	100	0	P	H	
													H	
													H	
			11400	45.87	-28.13	74	51.61	40.02	15.38	61.42	100	0	P	V
			17100	47.21	-26.79	74	45.76	40.06	19.18	58.14	100	0	P	V
														V
Remark	1. No other spurious found.													
	2. All results are PASS against Peak and Average limit line.													



**Band 3 - 5470~5725MHz
WIFI 802.11n HT40 (Band Edge @ 3m)**

WIFI Ant. 1	Note	Frequency (MHz)	Level (dBμV/m)	Over Limit (dB)	Limit Line (dBμV/m)	Read Level (dBμV)	Antenna Factor (dB/m)	Cable Loss (dB)	Preamp Factor (dB)	Ant Pos (cm)	Table Pos (deg)	Peak Avg. (P/A)	Pol. (H/V)
802.11n HT40 CH 102 5510MHz		5470	52.75	-21.25	74	44.41	32.07	9.29	33.02	100	116	P	H
		5470	46.59	-7.41	54	38.25	32.07	9.29	33.02	100	116	A	H
	*	5510	97.1	-	-	88.66	32.1	9.37	33.03	100	116	P	H
	*	5510	89.53	-	-	81.09	32.1	9.37	33.03	100	116	A	H
		5744.21	48.75	-25.25	74	39.49	32.53	9.88	33.15	100	116	P	H
		5748.935	43.29	-10.71	54	34.03	32.53	9.88	33.15	100	116	A	H
		5468.56	50.69	-23.31	74	42.35	32.07	9.29	33.02	100	302	P	V
		5469.52	44.06	-9.94	54	35.72	32.07	9.29	33.02	100	302	A	V
	*	5510	91.41	-	-	82.97	32.1	9.37	33.03	100	302	P	V
	*	5510	84.94	-	-	76.5	32.1	9.37	33.03	100	302	A	V
		5741.69	49.04	-24.96	74	39.78	32.53	9.88	33.15	100	302	P	V
		5752.715	42.77	-11.23	54	33.47	32.57	9.88	33.15	100	302	A	V
802.11n HT40 CH 110 5550MHz		5424.4	48.9	-25.1	74	40.64	32.02	9.26	33.02	100	116	P	H
		5438.08	41.98	-12.02	54	33.71	32.03	9.26	33.02	100	116	A	H
	*	5550	97.05	-	-	88.47	32.19	9.44	33.05	100	116	P	H
	*	5550	89.32	-	-	80.74	32.19	9.44	33.05	100	116	A	H
		5758.07	50.63	-23.37	74	41.27	32.57	9.95	33.16	100	116	P	H
		5746.1	42.99	-11.01	54	33.73	32.53	9.88	33.15	100	116	A	H
		5409.28	48.21	-25.79	74	40.01	32	9.22	33.02	100	300	P	V
		5465.68	41.85	-12.15	54	33.51	32.07	9.29	33.02	100	300	A	V
	*	5550	92.54	-	-	83.96	32.19	9.44	33.05	100	300	P	V
	*	5550	84.77	-	-	76.19	32.19	9.44	33.05	100	300	A	V
	5752.715	49.51	-24.49	74	40.21	32.57	9.88	33.15	100	300	P	V	
	5745.47	43.01	-10.99	54	33.75	32.53	9.88	33.15	100	300	A	V	



802.11n HT40 CH 134 5670MHz		5437.5	48.79	-25.21	74	40.52	32.03	9.26	33.02	100	116	P	H
		5458.15	41.84	-12.16	54	33.52	32.05	9.29	33.02	100	116	A	H
	*	5670	97.36	-	-	88.38	32.41	9.68	33.11	100	116	P	H
	*	5670	90.04	-	-	81.06	32.41	9.68	33.11	100	116	A	H
		5728.25	49.93	-24.07	74	40.75	32.5	9.81	33.13	100	116	P	H
		5725.975	43.46	-10.54	54	34.28	32.5	9.81	33.13	100	116	A	H
		5388.85	49.17	-24.83	74	41.01	31.98	9.2	33.02	100	296	P	V
		5458.15	42.37	-11.63	54	34.05	32.05	9.29	33.02	100	296	A	V
	*	5670	93.75	-	-	84.77	32.41	9.68	33.11	100	296	P	V
	*	5670	86.47	-	-	77.49	32.41	9.68	33.11	100	296	A	V
		5756.075	48.48	-25.52	74	39.19	32.57	9.88	33.16	100	296	P	V
		5757.825	43.15	-10.85	54	33.79	32.57	9.95	33.16	100	296	A	V
Remark	1. No other spurious found. 2. All results are PASS against Peak and Average limit line.												



Band 3 - 5470~5725MHz
WIFI 802.11n HT40 (Harmonic @ 3m)

WIFI Ant. 1	Note	Frequency (MHz)	Level (dBμV/m)	Over Limit (dB)	Limit Line (dBμV/m)	Read Level (dBμV)	Antenna Factor (dB/m)	Cable Loss (dB)	Preamp Factor (dB)	Ant Pos (cm)	Table Pos (deg)	Peak Avg. (P/A)	Pol. (H/V)	
802.11n HT40 CH 102 5510MHz		11020	46.47	-27.53	74	52.47	40.1	15.11	61.5	100	0	P	H	
		16530	45.76	-28.24	74	47.73	38.58	18.76	59.61	100	0	P	H	
													H	
													H	
			11020	48.66	-25.34	74	54.66	40.1	15.11	61.5	100	0	P	V
			16530	44.79	-29.21	74	46.76	38.58	18.76	59.61	100	0	P	V
														V
802.11n HT40 CH 110 5550MHz		11100	45.88	-28.12	74	51.83	40.08	15.16	61.48	100	0	P	H	
		16650	44.9	-29.1	74	46.16	38.87	18.86	59.3	100	0	P	H	
													H	
													H	
			11100	48.74	-25.26	74	54.69	40.08	15.16	61.48	100	0	P	V
			16650	46.18	-27.82	74	47.44	38.87	18.86	59.3	100	0	P	V
														V
802.11n HT40 CH 134 5670MHz		11340	45.74	-28.26	74	51.52	40.03	15.33	61.43	100	0	P	H	
		17010	47.21	-26.79	74	46.33	39.76	19.14	58.36	100	0	P	H	
													H	
													H	
			11340	46.5	-27.5	74	52.28	40.03	15.33	61.43	100	0	P	V
			17010	46.4	-27.6	74	45.52	39.76	19.14	58.36	100	0	P	V
														V
Remark	1. No other spurious found.													
	2. All results are PASS against Peak and Average limit line.													



Emission below 1GHz
WIFI 802.11n HT40 (LF @ 3m)

WIFI	Note	Frequency	Level	Over	Limit	Read	Antenna	Cable	Preamp	Ant	Table	Peak	Pol.	
Ant.				Limit	Line	Level	Factor	Loss	Factor	Pos	Pos	Avg.		
1		(MHz)	(dBμV/m)	(dB)	(dBμV/m)	(dBμV)	(dB/m)	(dB)	(dB)	(cm)	(deg)	(P/A)	(H/V)	
802.11n HT40 LF		49.17	24.44	-15.56	40	41.42	14.48	1.02	32.49			P	H	
		51.6	26.74	-13.26	40	44.49	13.71	1.02	32.49			P	H	
		122.88	26.47	-17.03	43.5	40.12	17.26	1.51	32.46			P	H	
		484.1	24.86	-21.14	46	30.91	23.5	2.77	32.37			P	H	
		739.6	29.73	-16.27	46	30.83	27.72	3.4	32.35			P	H	
		946.8	33.67	-12.33	46	30.5	30.41	3.82	31.23	100	0	P	H	
													H	
													H	
													H	
													H	
													H	
													H	
			34.32	31.2	-8.8	40	40.55	22.31	0.82	32.49	100	35	P	V
			49.17	28.68	-11.32	40	45.66	14.48	1.02	32.49			P	V
			121.53	32.8	-10.7	43.5	46.4	17.31	1.51	32.46			P	V
			477.1	26.25	-19.75	46	32.39	23.41	2.77	32.37			P	V
			750.1	30.22	-15.78	46	31.17	27.81	3.44	32.33			P	V
			958.7	34.43	-11.57	46	30.45	31.02	3.9	31.12			P	V
													V	
													V	
												V		
												V		
												V		
												V		
Remark	1. No other spurious found. 2. All results are PASS against limit line.													



Note symbol

*	Fundamental Frequency which can be ignored. However, the level of any unwanted emissions shall not exceed the level of the fundamental frequency.
!	Test result is over limit line.
P/A	P eak or A verage
H/V	H orizontal or V ertical



A calculation example for radiated spurious emission is shown as below:

WIFI	Note	Frequency	Level	Over	Limit	Read	Antenna	Cable	Preamp	Ant	Table	Peak	Pol.
Ant.				Limit	Line	Level	Factor	Loss	Factor	Pos	Pos	Avg.	
1		(MHz)	(dBμV/m)	(dB)	(dBμV/m)	(dBμV)	(dB/m)	(dB)	(dB)	(cm)	(deg)	(P/A)	(H/V)
802.11b		2390	55.45	-18.55	74	54.51	32.22	4.58	35.86	103	308	P	H
CH 01													
2412MHz		2390	43.54	-10.46	54	42.6	32.22	4.58	35.86	103	308	A	H

- Level(dBμV/m) =
Antenna Factor(dB/m) + Cable Loss(dB) + Read Level(dBμV) - Preamp Factor(dB)
- Over Limit(dB) = Level(dBμV/m) – Limit Line(dBμV/m)

For Peak Limit @ 2390MHz:

- Level(dBμV/m)
= Antenna Factor(dB/m) + Cable Loss(dB) + Read Level(dBμV) - Preamp Factor(dB)
= 32.22(dB/m) + 4.58(dB) + 54.51(dBμV) – 35.86 (dB)
= 55.45 (dBμV/m)
- Over Limit(dB)
= Level(dBμV/m) – Limit Line(dBμV/m)
= 55.45(dBμV/m) – 74(dBμV/m)
= -18.55(dB)

For Average Limit @ 2390MHz:

- Level(dBμV/m)
= Antenna Factor(dB/m) + Cable Loss(dB) + Read Level(dBμV) - Preamp Factor(dB)
= 32.22(dB/m) + 4.58(dB) + 42.6(dBμV) – 35.86 (dB)
= 43.54 (dBμV/m)
- Over Limit(dB)
= Level(dBμV/m) – Limit Line(dBμV/m)
= 43.54(dBμV/m) – 54(dBμV/m)
= -10.46(dB)

Both peak and average measured complies with the limit line, so test result is “PASS”.



Appendix D. Radiated Spurious Emission

Test Engineer :	Hao Hsu, Jacky Hung, and Ken Wu	Temperature :	23~26°C
		Relative Humidity :	50~55%

Note symbol

-L	Low channel location
-R	High channel location



Band 1 - 5150~5250MHz
WIFI 802.11a (Band Edge @ 3m)

WIFI	Band 1 5150~5250MHz Band Edge @ 3m	
ANT	802.11a CH36 5180MHz	
1	Horizontal	Fundamental
Peak	<p>Site : 03CH11-HY Condition : PEAK_BE_74 3m HORN 9120D-HF HORIZONTAL RBW:1000.000KHz VBW:3000.000KHz SWT:Auto Detector : Peak Project : 7D2018</p>	<p>Site : 03CH11-HY Condition : PEAK_74 3m HORN 9120D-HF HORIZONTAL RBW:1000.000KHz VBW:3000.000KHz SWT:Auto Detector : Peak Project : 7D2018</p>
Avg.	<p>Site : 03CH11-HY Condition : AVG_BE_54 3m HORN 9120D-HF HORIZONTAL RBW:1000.000KHz VBW:1.000KHz SWT:Auto Detector : Peak Project : 7D2018</p>	Left blank



WIFI	Band 1 5150~5250MHz Band Edge @ 3m	
ANT	802.11a CH36 5180MHz	
1	Vertical	Fundamental
Peak	<p>Site : 03CH11-HY Condition : PEAK_BE_74 3m HORN 91200-HF VERTICAL RBW:1000.000KHz VBW:3000.000KHz SWT:Auto Detector : Peak Project : 7D2018</p>	<p>Site : 03CH11-HY Condition : PEAK_74 3m HORN 91200-HF VERTICAL RBW:1000.000KHz VBW:3000.000KHz SWT:Auto Detector : Peak Project : 7D2018</p>
Avg.	<p>Site : 03CH11-HY Condition : AVG_BE_54 3m HORN 91200-HF VERTICAL RBW:1000.000KHz VBW:1000KHz SWT:Auto Detector : Peak Project : 7D2018</p>	Left blank



WIFI	Band 1 5150~5250MHz Band Edge @ 3m	
ANT	802.11a CH44 5220MHz - L	
1	Horizontal	Fundamental
Peak	<p>Site : 03CH11-HY Condition : PEAK_BE_74 3m HORN 91200-HF HORIZONTAL : RBW:1000.000KHz VBW:3000.000KHz SWT:Auto Detector : Peak Project : 7D2018</p>	<p>Site : 03CH11-HY Condition : PEAK_74 3m HORN 91200-HF HORIZONTAL : RBW:1000.000KHz VBW:3000.000KHz SWT:Auto Detector : Peak Project : 7D2018</p>
Avg.	<p>Site : 03CH11-HY Condition : AVG_BE_54 3m HORN 91200-HF HORIZONTAL : RBW:1000.000KHz VBW:1000KHz SWT:Auto Detector : Peak Project : 7D2018</p>	Left blank

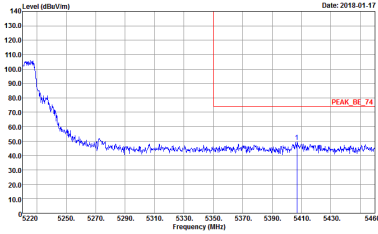
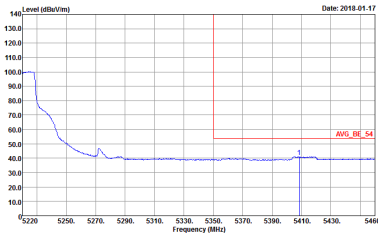

WIFI	Band 1 5150~5250MHz Band Edge @ 3m	
ANT	802.11a CH44 5220MHz - R	
1	Horizontal	Fundamental
Peak	 <p>Site : 03CH11-HY Condition : PEAK_BE_74 3m HORN 91200-HF HORIZONTAL RBW:1000.000KHz VBW:3000.000KHz SWF:Auto Detector : Peak Project : 7D2018</p>	Left blank
Avg.	 <p>Site : 03CH11-HY Condition : AVG_BE_54 3m HORN 91200-HF HORIZONTAL RBW:1000.000KHz VBW:1.000KHz SWF:Auto Detector : Peak Project : 7D2018</p>	Left blank

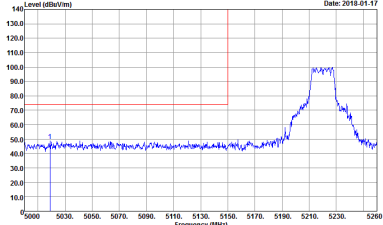
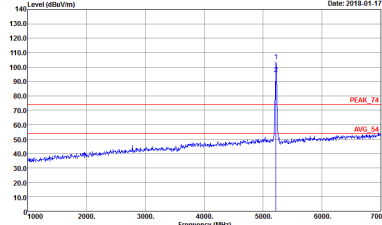
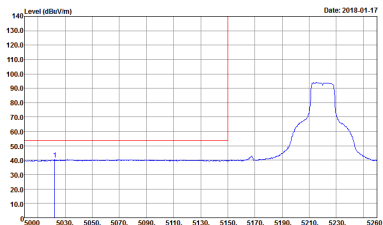

WIFI	Band 1 5150~5250MHz Band Edge @ 3m	
ANT	802.11a CH44 5220MHz - L	
1	Vertical	Fundamental
Peak	 <p>Site : 03CH11-HY Condition : PEAK_BE_74 3m HORN 91200-HF VERTICAL RBW:1000.000KHz VBW:3000.000KHz SWT:Auto Detector : Peak Project : 7D2018</p>	 <p>Site : 03CH11-HY Condition : PEAK_74 3m HORN 91200-HF VERTICAL RBW:1000.000KHz VBW:3000.000KHz SWT:Auto Detector : Peak Project : 7D2018</p>
Avg.	 <p>Site : 03CH11-HY Condition : AVG_BE_54 3m HORN 91200-HF VERTICAL RBW:1000.000KHz VBW:1000KHz SWT:Auto Detector : Peak Project : 7D2018</p>	Left blank

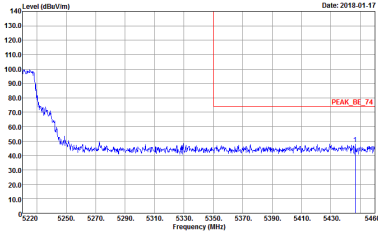
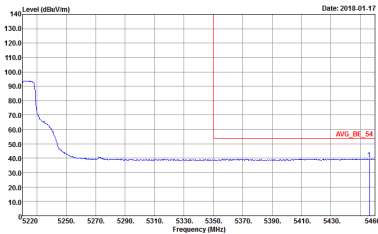

WIFI	Band 1 5150~5250MHz Band Edge @ 3m	
ANT	802.11a CH44 5220MHz - R	
1	Vertical	Fundamental
Peak	 <p>Site : 03CH11-HY Condition : PEAK_BE_74 3m HORN 91200-HF VERTICAL RBW:1000.000KHz VBW:3000.000KHz SWF:Auto Detector : Peak Project : 7D2018</p>	Left blank
Avg.	 <p>Site : 03CH11-HY Condition : AVG_BE_54 3m HORN 91200-HF VERTICAL RBW:1000.000KHz VBW:1000KHz SWF:Auto Detector : Peak Project : 7D2018</p>	Left blank



WIFI	Band 1 5150~5250MHz Band Edge @ 3m	
ANT	802.11a CH48 5240MHz - L	
1	Horizontal	Fundamental
Peak	<p>Site : 03CH11-HY Condition : PEAK_BE_74 3m HORN 91200-HF HORIZONTAL RBW:1000.000KHz VBW:3000.000KHz SWT:Auto Detector : Peak Project : 7D2018</p>	<p>Site : 03CH11-HY Condition : PEAK_74 3m HORN 91200-HF HORIZONTAL RBW:1000.000KHz VBW:3000.000KHz SWT:Auto Detector : Peak Project : 7D2018</p>
Avg.	<p>Site : 03CH11-HY Condition : AVG_BE_54 3m HORN 91200-HF HORIZONTAL RBW:1000.000KHz VBW:1000KHz SWT:Auto Detector : Peak Project : 7D2018</p>	Left blank

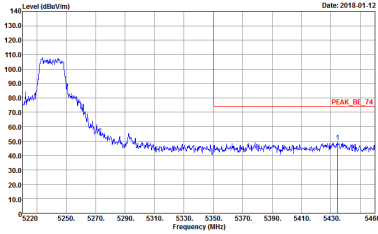
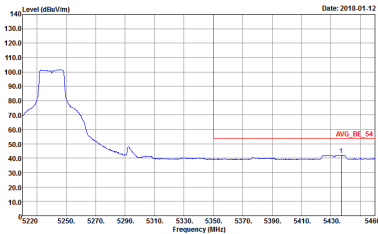

WIFI	Band 1 5150~5250MHz Band Edge @ 3m	
ANT	802.11a CH48 5240MHz - R	
1	Horizontal	Fundamental
Peak	 <p>Site : 03CH11-HY Condition : PEAK_BE_74 3m HORN 91200-HF HORIZONTAL RBW:1000.000KHz VBW:3000.000KHz SWF:Auto Detector : Peak Project : 7D2018</p>	Left blank
Avg.	 <p>Site : 03CH11-HY Condition : AVG_BE_54 3m HORN 91200-HF HORIZONTAL RBW:1000.000KHz VBW:1000KHz SWF:Auto Detector : Peak Project : 7D2018</p>	Left blank



WIFI	Band 1 5150~5250MHz Band Edge @ 3m	
ANT	802.11a CH48 5240MHz - L	
1	Vertical	Fundamental
Peak	<p>Site : 03CH11-HY Condition : PEAK_BE_74 3m HORN 91200-HF VERTICAL RBW:1000.000KHz VBW:3000.000KHz SWT:Auto Detector : Peak Project : 7D2018</p>	<p>Site : 03CH11-HY Condition : PEAK_74 3m HORN 91200-HF VERTICAL RBW:1000.000KHz VBW:3000.000KHz SWT:Auto Detector : Peak Project : 7D2018</p>
Avg.	<p>Site : 03CH11-HY Condition : AVG_BE_54 3m HORN 91200-HF VERTICAL RBW:1000.000KHz VBW:1000KHz SWT:Auto Detector : Peak Project : 7D2018</p>	Left blank

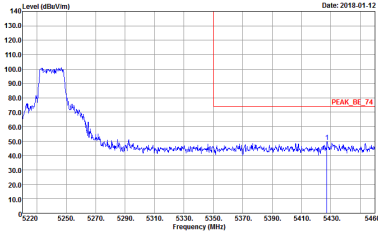
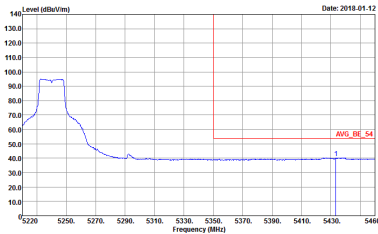

WIFI	Band 1 5150~5250MHz Band Edge @ 3m	
ANT	802.11a CH48 5240MHz - R	
1	Vertical	Fundamental
<p>Peak</p>	 <p>Site : 03CH11-HY Condition : PEAK_BE_74 3m HORN 91200-HF VERTICAL RBW:1000.000KHz VBW:3000.000KHz SWF:Auto Detector : Peak Project : 7D2018</p>	<p>Left blank</p>
<p>Avg.</p>	 <p>Site : 03CH11-HY Condition : AVG_BE_54 3m HORN 91200-HF VERTICAL RBW:1000.000KHz VBW:1000KHz SWF:Auto Detector : Peak Project : 7D2018</p>	<p>Left blank</p>



Band 1 5150~5250MHz
WIFI 802.11n HT20 (Band Edge @ 3m)

WIFI	Band 1 5150~5250MHz Band Edge @ 3m	
ANT	802.11n HT20 CH36 5180MHz	
1	Horizontal	Fundamental
Peak	<p>Site : 03CH11-HY Condition : PEAK_BE_74 3m HORN 91200-HF HORIZONTAL Detector : Peak Project : 7D2018</p>	<p>Site : 03CH11-HY Condition : PEAK_74 3m HORN 91200-HF HORIZONTAL Detector : Peak Project : 7D2018</p>
Avg.	<p>Site : 03CH11-HY Condition : AVG_BE_54 3m HORN 91200-HF HORIZONTAL Detector : Peak Project : 7D2018</p>	Left blank



WIFI	Band 1 5150~5250MHz Band Edge @ 3m	
ANT	802.11n HT20 CH36 5180MHz	
1	Vertical	Fundamental
Peak	<p>Site : 03CH11-HY Condition : PEAK_BE_74 3m HORN 91200-HF VERTICAL RBW:1000.000KHz VBW:3000.000KHz SWT:Auto Detector : Peak Project : 7D2018</p>	<p>Site : 03CH11-HY Condition : PEAK_74 3m HORN 91200-HF VERTICAL RBW:1000.000KHz VBW:3000.000KHz SWT:Auto Detector : Peak Project : 7D2018</p>
Avg.	<p>Site : 03CH11-HY Condition : AVG_BE_54 3m HORN 91200-HF VERTICAL RBW:1000.000KHz VBW:1000KHz SWT:Auto Detector : Peak Project : 7D2018</p>	Left blank



WIFI	Band 1 5150~5250MHz Band Edge @ 3m	
ANT	802.11n HT20 CH44 5220MHz - L	
1	Horizontal	Fundamental
Peak	<p>Site : 03CH11-HY Condition : PEAK_BE_74 3m HORN 91200-HF HORIZONTAL RBW:1000.000KHz VBW:3000.000KHz SWT:Auto Detector : Peak Project : 7D2018</p>	<p>Site : 03CH11-HY Condition : PEAK_74 3m HORN 91200-HF HORIZONTAL RBW:1000.000KHz VBW:3000.000KHz SWT:Auto Detector : Peak Project : 7D2018</p>
Avg.	<p>Site : 03CH11-HY Condition : AVG_BE_54 3m HORN 91200-HF HORIZONTAL RBW:1000.000KHz VBW:1000KHz SWT:Auto Detector : Peak Project : 7D2018</p>	Left blank

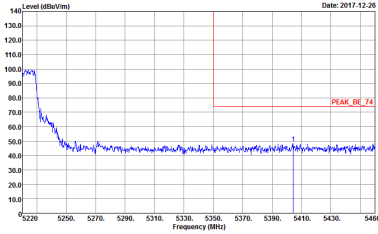
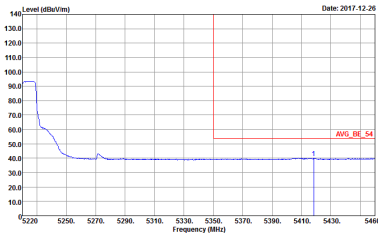

WIFI	Band 1 5150~5250MHz Band Edge @ 3m	
ANT	802.11n HT20 CH44 5220MHz - R	
1	Horizontal	Fundamental
<p>Peak</p>	 <p>Site : 03CH11-HY Condition : PEAK_BE_74 3m HORN 91200-HF HORIZONTAL RBW:1000.000KHz VBW:3000.000KHz SWF:Auto Detector : Peak Project : 7D2018</p>	<p>Left blank</p>
<p>Avg.</p>	 <p>Site : 03CH11-HY Condition : AVG_BE_54 3m HORN 91200-HF HORIZONTAL RBW:1000.000KHz VBW:1.000KHz SWF:Auto Detector : Peak Project : 7D2018</p>	<p>Left blank</p>

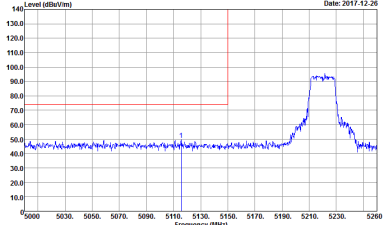
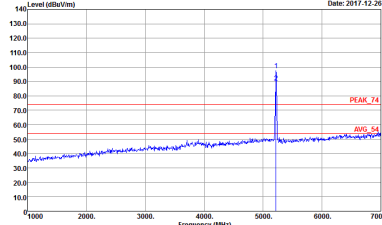
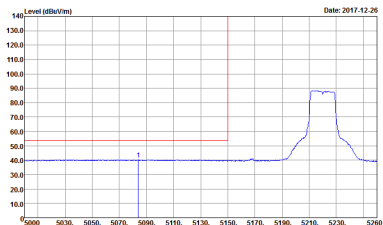

WIFI	Band 1 5150~5250MHz Band Edge @ 3m	
ANT	802.11n HT20 CH44 5220MHz - L	
1	Vertical	Fundamental
Peak	 <p>Site : 03CH11-HY Condition : PEAK_BE_74 3m HORN 91200-HF VERTICAL RBW:1000.000kHz VBW:3000.000kHz SWT:Auto Detector : Peak Project : 7D2018</p>	 <p>Site : 03CH11-HY Condition : PEAK_74 3m HORN 91200-HF VERTICAL RBW:1000.000kHz VBW:3000.000kHz SWT:Auto Detector : Peak Project : 7D2018</p>
Avg.	 <p>Site : 03CH11-HY Condition : AVG_BE_54 3m HORN 91200-HF VERTICAL RBW:1000.000kHz VBW:1000kHz SWT:Auto Detector : Peak Project : 7D2018</p>	Left blank

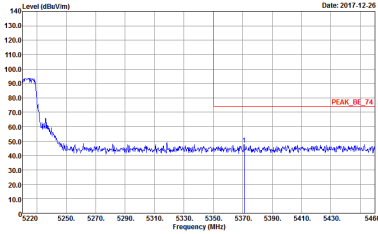
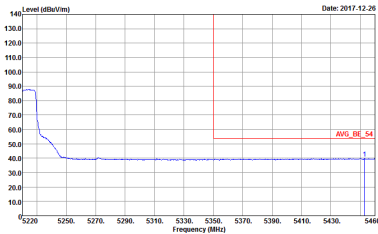

WIFI	Band 1 5150~5250MHz Band Edge @ 3m	
ANT	802.11n HT20 CH44 5220MHz - R	
1	Vertical	Fundamental
Peak	 <p>Site : 03CH11-HY Condition : PEAK_BE_74 3m HORN 91200-HF VERTICAL RBW:1000.000KHz VBW:3000.000KHz SWT:Auto Detector : Peak Project : 7D2018</p>	Left blank
Avg.	 <p>Site : 03CH11-HY Condition : AVG_BE_54 3m HORN 91200-HF VERTICAL RBW:1000.000KHz VBW:1000KHz SWT:Auto Detector : Peak Project : 7D2018</p>	Left blank



WIFI	Band 1 5150~5250MHz Band Edge @ 3m	
ANT	802.11n HT20 CH48 5240MHz - L	
1	Horizontal	Fundamental
Peak	<p>Site : 03CH11-HY Condition : PEAK_BE_74 3m HORN 91200-HF HORIZONTAL RBW:1000.000KHz VBW:3000.000KHz SWT:Auto Detector : Peak Project : 7D2018</p>	<p>Site : 03CH11-HY Condition : PEAK_74 3m HORN 91200-HF HORIZONTAL RBW:1000.000KHz VBW:3000.000KHz SWT:Auto Detector : Peak Project : 7D2018</p>
Avg.	<p>Site : 03CH11-HY Condition : AVG_BE_54 3m HORN 91200-HF HORIZONTAL RBW:1000.000KHz VBW:1000KHz SWT:Auto Detector : Peak Project : 7D2018</p>	Left blank

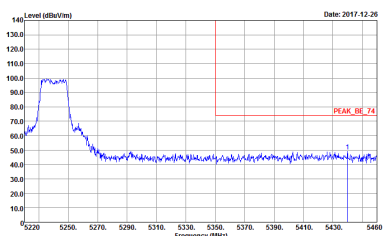
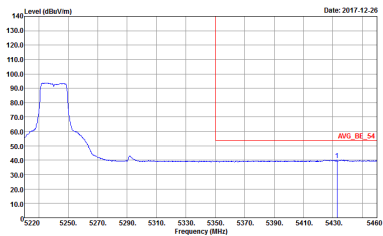

WIFI	Band 1 5150~5250MHz Band Edge @ 3m	
ANT	802.11n HT20 CH48 5240MHz - R	
1	Horizontal	Fundamental
Peak	 <p>Site : 03CH11-HY Condition : PEAK_BE_74 3m HORN 91200-HF HORIZONTAL RBW:1000.000KHz VBW:3000.000KHz SWF:Auto Detector : Peak Project : 7D2018</p>	Left blank
Avg.	 <p>Site : 03CH11-HY Condition : AVG_BE_54 3m HORN 91200-HF HORIZONTAL RBW:1000.000KHz VBW:1.000KHz SWF:Auto Detector : Peak Project : 7D2018</p>	Left blank



WIFI	Band 1 5150~5250MHz Band Edge @ 3m	
ANT	802.11n HT20 CH48 5240MHz - L	
1	Vertical	Fundamental
Peak	<p>Site : 03CH11-HY Condition : PEAK_BE_74 3m HORN 91200-HF VERTICAL RBW:1000.000KHz VBW:3000.000KHz SWT:Auto Detector : Peak Project : 7D2018</p>	<p>Site : 03CH11-HY Condition : PEAK_74 3m HORN 91200-HF VERTICAL RBW:1000.000KHz VBW:3000.000KHz SWT:Auto Detector : Peak Project : 7D2018</p>
Avg.	<p>Site : 03CH11-HY Condition : AVG_BE_54 3m HORN 91200-HF VERTICAL RBW:1000.000KHz VBW:1000KHz SWT:Auto Detector : Peak Project : 7D2018</p>	Left blank



WIFI	Band 1 5150~5250MHz Band Edge @ 3m	
ANT	802.11n HT20 CH48 5240MHz - R	
1	Vertical	Fundamental
<p>Peak</p>	<p>Site : 03CH11-HY Condition : PEAK_BE_74 3m HORN 91200-HF VERTICAL RBW:1000.000KHz VBW:3000.000KHz SWF:Auto Detector : Peak Project : 7D2018</p>	<p>Left blank</p>
<p>Avg.</p>	<p>Site : 03CH11-HY Condition : AVG_BE_54 3m HORN 91200-HF VERTICAL RBW:1000.000KHz VBW:1000KHz SWF:Auto Detector : Peak Project : 7D2018</p>	<p>Left blank</p>



Band 1 5150~5250MHz
WIFI 802.11n HT40 (Band Edge @ 3m)

WIFI	Band 1 5150~5250MHz Band Edge @ 3m	
ANT	802.11n HT40 CH38 5190MHz - L	
1	Horizontal	Fundamental
Peak	<p>Site : 03CH11-HY Condition : PEAK_BE_74 3m HORN 91200-HF HORIZONTAL : RBW:1000.000KHz VBW:3000.000KHz SWT:Auto Detector : Peak Project : 7D2018</p>	<p>Site : 03CH11-HY Condition : PEAK_74 3m HORN 91200-HF HORIZONTAL : RBW:1000.000KHz VBW:3000.000KHz SWT:Auto Detector : Peak Project : 7D2018</p>
Avg.	<p>Site : 03CH11-HY Condition : AVG_BE_54 3m HORN 91200-HF HORIZONTAL : RBW:1000.000KHz VBW:10.000KHz SWT:Auto Detector : Peak Project : 7D2018</p>	Left blank

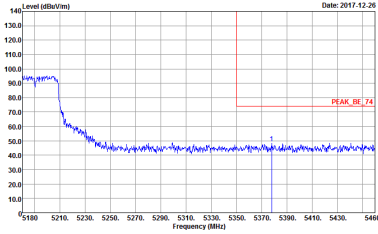
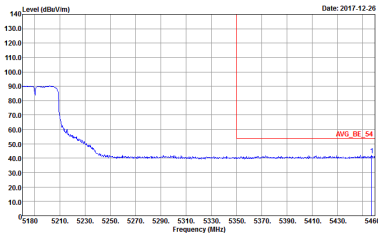

WIFI	Band 1 5150~5250MHz Band Edge @ 3m	
ANT	802.11n HT40 CH38 5190MHz - R	
1	Horizontal	Fundamental
<p>Peak</p>	 <p>Site : 03CH11-HY Condition : PEAK_BE_74 3m HORN 91200-HF HORIZONTAL RBW:1000.000kHz VBW:3000.000kHz SWT:Auto Detector : Peak Project : 7D2018</p>	<p>Left blank</p>
<p>Avg.</p>	 <p>Site : 03CH11-HY Condition : AVG_BE_54 3m HORN 91200-HF HORIZONTAL RBW:1000.000kHz VBW:10.000kHz SWT:Auto Detector : Peak Project : 7D2018</p>	<p>Left blank</p>



WIFI	Band 1 5150~5250MHz Band Edge @ 3m	
ANT	802.11n HT40 CH38 5190MHz - L	
1	Vertical	Fundamental
Peak	<p>Site : 03CH11-HY Condition : PEAK_BE_74 3m HORN 91200-HF VERTICAL RBW:1000.000KHz VBW:3000.000KHz SWT:Auto Detector : Peak Project : 7D2018</p>	<p>Site : 03CH11-HY Condition : PEAK_74 3m HORN 91200-HF VERTICAL RBW:1000.000KHz VBW:3000.000KHz SWT:Auto Detector : Peak Project : 7D2018</p>
Avg.	<p>Site : 03CH11-HY Condition : AVG_BE_54 3m HORN 91200-HF VERTICAL RBW:1000.000KHz VBW:10.000KHz SWT:Auto Detector : Peak Project : 7D2018</p>	Left blank

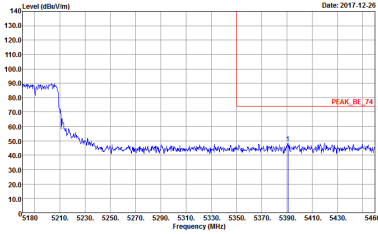
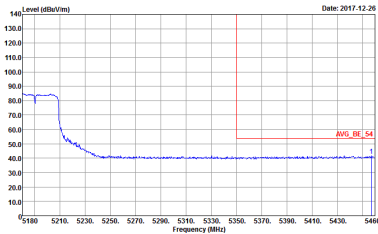

WIFI	Band 1 5150~5250MHz Band Edge @ 3m	
ANT	802.11n HT40 CH38 5190MHz - R	
1	Vertical	Fundamental
Peak	 <p>Site : 03CH11-HY Condition : PEAK_BE_74 3m HORN 91200-HF VERTICAL RBW:1000.000kHz VBW:3000.000kHz SWT:Auto Detector : Peak Project : 7D2018</p>	Left blank
Avg.	 <p>Site : 03CH11-HY Condition : AVG_BE_54 3m HORN 91200-HF VERTICAL RBW:1000.000kHz VBW:10.000kHz SWT:Auto Detector : Peak Project : 7D2018</p>	Left blank



WIFI	Band 1 5150~5250MHz Band Edge @ 3m	
ANT	802.11n HT40 CH46 5230MHz - L	
1	Horizontal	Fundamental
Peak	<p>Site : 03CH11-HY Condition : PEAK_BE_74 3m HORN 91200-HF HORIZONTAL RBW:1000.000KHz VBW:3000.000KHz SWT:Auto Detector : Peak Project : 7D2018</p>	<p>Site : 03CH11-HY Condition : PEAK_74 3m HORN 91200-HF HORIZONTAL RBW:1000.000KHz VBW:3000.000KHz SWT:Auto Detector : Peak Project : 7D2018</p>
Avg.	<p>Site : 03CH11-HY Condition : AVG_BE_54 3m HORN 91200-HF HORIZONTAL RBW:1000.000KHz VBW:10.000KHz SWT:Auto Detector : Peak Project : 7D2018</p>	Left blank

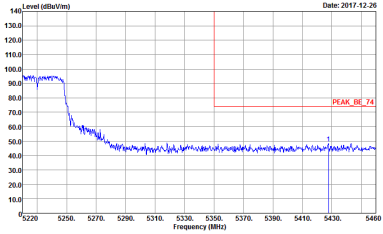
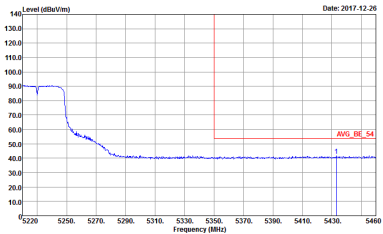

WIFI	Band 1 5150~5250MHz Band Edge @ 3m	
ANT	802.11n HT40 CH46 5230MHz - R	
1	Horizontal	Fundamental
Peak	 <p>Site : 03CH11-HY Condition : PEAK_BE_74 3m HORN 91200-HF HORIZONTAL RBW:1000.000kHz VBW:3000.000kHz SWT:Auto Detector : Peak Project : 7D2018</p>	Left blank
Avg.	 <p>Site : 03CH11-HY Condition : AVG_BE_54 3m HORN 91200-HF HORIZONTAL RBW:1000.000kHz VBW:30.000kHz SWT:Auto Detector : Peak Project : 7D2018</p>	Left blank



WIFI	Band 1 5150~5250MHz Band Edge @ 3m	
ANT	802.11n HT40 CH46 5230MHz - L	
1	Vertical	Fundamental
Peak	<p>Site : 03CH11-HY Condition : PEAK_BE_74 3m HORN 91200-HF VERTICAL RBW:1000.000KHz VBW:3000.000KHz SWT:Auto Detector : Peak Project : 7D2018</p>	<p>Site : 03CH11-HY Condition : PEAK_74 3m HORN 91200-HF VERTICAL RBW:1000.000KHz VBW:3000.000KHz SWT:Auto Detector : Peak Project : 7D2018</p>
Avg.	<p>Site : 03CH11-HY Condition : AVG_BE_54 3m HORN 91200-HF VERTICAL RBW:1000.000KHz VBW:10.000KHz SWT:Auto Detector : Peak Project : 7D2018</p>	Left blank



WIFI	Band 1 5150~5250MHz Band Edge @ 3m	
ANT	802.11n HT40 CH46 5230MHz - R	
1	Vertical	Fundamental
Peak	<p>Site : 03CH11-HY Condition : PEAK_BE_74 3m HORN 91200-HF VERTICAL RBW:1000.000kHz VBW:3000.000kHz SWT:Auto Detector : Peak Project : 7D2018</p>	Left blank
Avg.	<p>Site : 03CH11-HY Condition : AVG_BE_54 3m HORN 91200-HF VERTICAL RBW:1000.000kHz VBW:10.000kHz SWT:Auto Detector : Peak Project : 7D2018</p>	Left blank



Band 1 - 5150~5250MHz
WIFI 802.11a (Harmonic @ 3m)

WIFI	Band 1 5150~5250MHz Harmonic @ 3m	
ANT	802.11a CH36 5180MHz	
1	Horizontal	Vertical
Peak Avg.	<p>Site : 03CH11-1F Condition : PEAK_74 3m HORN 9120D-HF HORIZONTAL Project : 7D2018</p>	<p>Site : 03CH11-1F Condition : PEAK_74 3m HORN 9120D-HF VERTICAL Project : 7D2018</p>

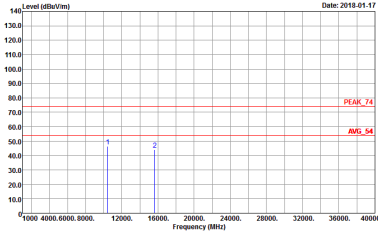
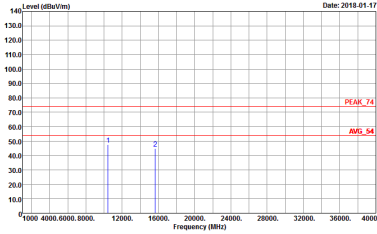

WIFI	Band 1 5150~5250MHz Harmonic @ 3m	
ANT	802.11a CH44 5220MHz	
1	Horizontal	Vertical
<p>Peak</p> <p>Avg.</p>	 <p>Site : 03CH11-HY Condition : PEAK_74 3m HORN 9120D-HF HORIZONTAL Project : 7D2018</p>	 <p>Site : 03CH11-HY Condition : PEAK_74 3m HORN 9120D-HF VERTICAL Project : 7D2018</p>



WIFI	Band 1 5150~5250MHz Harmonic @ 3m	
ANT	802.11a CH48 5240MHz	
1	Horizontal	Vertical
Peak Avg.	<p>Site : 03CH11-HY Condition : PEAK_74 3m HORN 9120D-HF HORIZONTAL Project : 7D2018</p>	<p>Site : 03CH11-HY Condition : PEAK_74 3m HORN 9120D-HF VERTICAL Project : 7D2018</p>



Band 1 5150~5250MHz
WIFI 802.11n HT20 (Harmonic @ 3m)

Table with 2 columns: Horizontal and Vertical. Each column contains a graph of Level (dBu/m) vs Frequency (MHz) with peak and average values indicated. Includes site information: 03GH11-HY, PEAK_74 3m HORN 9120D-HF HORIZONTAL, 7D2018.

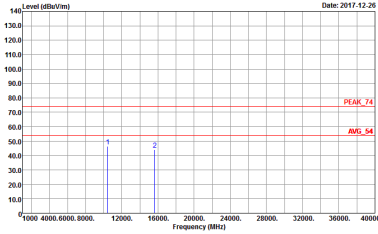
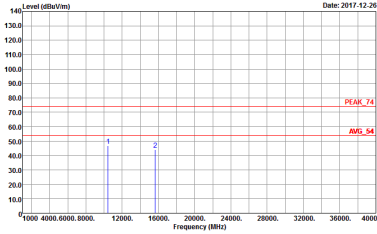

WIFI	Band 1 5150~5250MHz Harmonic @ 3m	
ANT	802.11n HT20 CH44 5220MHz	
1	Horizontal	Vertical
<p>Peak</p> <p>Avg.</p>	 <p>Site : 03CH11-HY Condition : PEAK_74 3m HORN 9120D-HF HORIZONTAL Project : 7D2018</p>	 <p>Site : 03CH11-HY Condition : PEAK_74 3m HORN 9120D-HF VERTICAL Project : 7D2018</p>

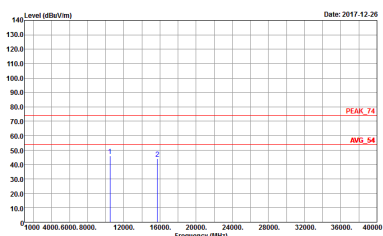
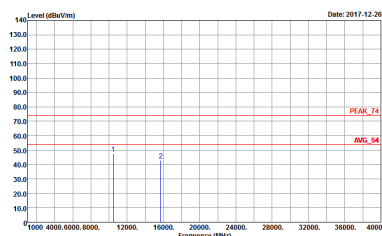

WIFI	Band 1 5150~5250MHz Harmonic @ 3m	
ANT	802.11n HT20 CH48 5240MHz	
1	Horizontal	Vertical
<p>Peak</p> <p>Avg.</p>	 <p>Site : 03CH11-HY Condition : PEAK_74 3m HORN 9120D-HF HORIZONTAL Project : 7D2018</p>	 <p>Site : 03CH11-HY Condition : PEAK_74 3m HORN 9120D-HF VERTICAL Project : 7D2018</p>



Band 1 5150~5250MHz
WIFI 802.11n HT40 (Harmonic @ 3m)

Table with 2 columns: Horizontal and Vertical. Each column contains a graph of Level (dBu/m) vs Frequency (MHz) with peak and average values indicated. Includes site information: 03GH11-HY, PEAK_74 3m HORN 9120D-HF HORIZONTAL, 7D2018.



WIFI	Band 1 5150~5250MHz Harmonic @ 3m	
ANT	802.11n HT40 CH46 5230MHz	
1	Horizontal	Vertical
Peak Avg.	<p>Site : 03CH11-HY Condition : PEAK_74 3m HORN 9120D-HF HORIZONTAL Project : 7D2018</p>	<p>Site : 03CH11-HY Condition : PEAK_74 3m HORN 9120D-HF VERTICAL Project : 7D2018</p>



Band 2 - 5250~5350MHz
WIFI 802.11a (Band Edge @ 3m)

WIFI	Band 2 5250~5350MHz Band Edge @ 3m	
ANT	802.11a CH52 5260MHz - L	
1	Horizontal	Fundamental
Peak	<p>Site : 03CH11-HY Condition : PEAK_BE_74 3m HORN 91200-HF HORIZONTAL RBW:1000.000KHz VBW:3000.000KHz SWT:Auto Detector : Peak Project : 7D2018</p>	<p>Site : 03CH11-HY Condition : PEAK_74 3m HORN 91200-HF HORIZONTAL RBW:1000.000KHz VBW:3000.000KHz SWT:Auto Detector : Peak Project : 7D2018</p>
Avg.	<p>Site : 03CH11-HY Condition : AVG_BE_54 3m HORN 91200-HF HORIZONTAL RBW:1000.000KHz VBW:1000KHz SWT:Auto Detector : Peak Project : 7D2018</p>	Left blank



WIFI	Band 2 5250~5350MHz Band Edge @ 3m	
ANT	802.11a CH52 5260MHz - R	
1	Horizontal	Fundamental
Peak	<p>Site : 03CH11-HY Condition : PEAK_BE_74 3m HORN 91200-HF HORIZONTAL RBW:1000.000KHz VBW:3000.000KHz SWF:Auto Detector : Peak Project : 7D2018</p>	Left blank
Avg.	<p>Site : 03CH11-HY Condition : AVG_BE_54 3m HORN 91200-HF HORIZONTAL RBW:1000.000KHz VBW:1000KHz SWF:Auto Detector : Peak Project : 7D2018</p>	Left blank



WIFI	Band 2 5250~5350MHz Band Edge @ 3m	
ANT	802.11a CH52 5260MHz - L	
1	Vertical	Fundamental
Peak	<p>Site : 03CH11-HY Condition : PEAK_BE_74 3m HORN 91200-HF VERTICAL RBW:1000.000KHz VBW:3000.000KHz SWT:Auto Detector : Peak Project : 7D2018</p>	<p>Site : 03CH11-HY Condition : PEAK_74 3m HORN 91200-HF VERTICAL RBW:1000.000KHz VBW:3000.000KHz SWT:Auto Detector : Peak Project : 7D2018</p>
Avg.	<p>Site : 03CH11-HY Condition : AVG_BE_54 3m HORN 91200-HF VERTICAL RBW:1000.000KHz VBW:1.000KHz SWT:Auto Detector : Peak Project : 7D2018</p>	Left blank



WIFI	Band 2 5250~5350MHz Band Edge @ 3m	
ANT	802.11a CH52 5260MHz - R	
1	Vertical	Fundamental
<p>Peak</p>	<p>Site : 03CH11-HY Condition : PEAK_BE_74 3m HORN 91200-HF VERTICAL RBW:1000.000KHz VBW:3000.000KHz SWF:Auto Detector : Peak Project : 7D2018</p>	<p>Left blank</p>
<p>Avg.</p>	<p>Site : 03CH11-HY Condition : AVG_BE_54 3m HORN 91200-HF VERTICAL RBW:1000.000KHz VBW:1000KHz SWF:Auto Detector : Peak Project : 7D2018</p>	<p>Left blank</p>



WIFI	Band 2 5250~5350MHz Band Edge @ 3m	
ANT	802.11a CH60 5300MHz - L	
1	Horizontal	Fundamental
Peak	<p>Site : 03CH11-HY Condition : PEAK_BE_74 3m HORN 91200-HF HORIZONTAL RBW:1000.000KHz VBW:3000.000KHz SWT:Auto Detector : Peak Project : 7D2018</p>	<p>Site : 03CH11-HY Condition : PEAK_74 3m HORN 91200-HF HORIZONTAL RBW:1000.000KHz VBW:3000.000KHz SWT:Auto Detector : Peak Project : 7D2018</p>
Avg.	<p>Site : 03CH11-HY Condition : AVG_BE_54 3m HORN 91200-HF HORIZONTAL RBW:1000.000KHz VBW:1000KHz SWT:Auto Detector : Peak Project : 7D2018</p>	Left blank

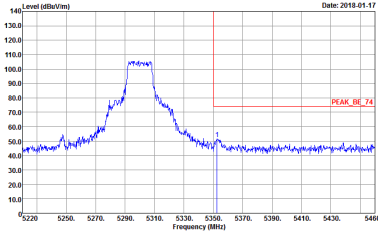
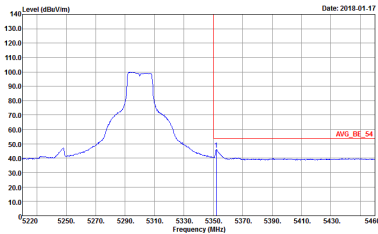

WIFI	Band 2 5250~5350MHz Band Edge @ 3m	
ANT	802.11a CH60 5300MHz - R	
1	Horizontal	Fundamental
<p>Peak</p>	 <p>Site : 03CH11-HY Condition : PEAK_BE_74 3m HORN 91200-HF HORIZONTAL RBW:1000.000KHz VBW:3000.000KHz SWF:Auto Detector : Peak Project : 7D2018</p>	<p>Left blank</p>
<p>Avg.</p>	 <p>Site : 03CH11-HY Condition : AVG_BE_54 3m HORN 91200-HF HORIZONTAL RBW:1000.000KHz VBW:1000KHz SWF:Auto Detector : Peak Project : 7D2018</p>	<p>Left blank</p>



WIFI	Band 2 5250~5350MHz Band Edge @ 3m	
ANT	802.11a CH60 5300MHz - L	
1	Vertical	Fundamental
Peak	<p>Site : 03CH11-HY Condition : PEAK_BE_74 3m HORN 91200-HF VERTICAL RBW:1000.000KHz VBW:3000.000KHz SWT:Auto Detector : Peak Project : 7D2018</p>	<p>Site : 03CH11-HY Condition : PEAK_74 3m HORN 91200-HF VERTICAL RBW:1000.000KHz VBW:3000.000KHz SWT:Auto Detector : Peak Project : 7D2018</p>
Avg.	<p>Site : 03CH11-HY Condition : AVG_BE_54 3m HORN 91200-HF VERTICAL RBW:1000.000KHz VBW:1000KHz SWT:Auto Detector : Peak Project : 7D2018</p>	Left blank



WIFI	Band 2 5250~5350MHz Band Edge @ 3m	
ANT	802.11a CH60 5300MHz - R	
1	Vertical	Fundamental
<p>Peak</p>		<p>Left blank</p>
<p>Avg.</p>		<p>Left blank</p>



WIFI	Band 2 5250~5350MHz Band Edge @ 3m	
ANT	802.11a CH64 5320MHz	
1	Horizontal	Fundamental
Peak	<p>Site : 03CH11-HY Condition : PEAK_BE_74 3m HORN 91200-HF HORIZONTAL RBW:1000.000KHz VBW:3000.000KHz SWT:Auto Detector : Peak Project : 7D2018</p>	<p>Site : 03CH11-HY Condition : PEAK_74 3m HORN 91200-HF HORIZONTAL RBW:1000.000KHz VBW:3000.000KHz SWT:Auto Detector : Peak Project : 7D2018</p>
Avg.	<p>Site : 03CH11-HY Condition : AVG_BE_54 3m HORN 91200-HF HORIZONTAL RBW:1000.000KHz VBW:1000KHz SWT:Auto Detector : Peak Project : 7D2018</p>	Left blank

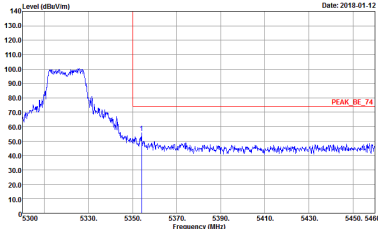
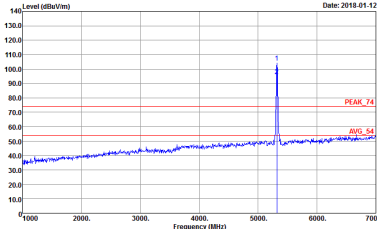
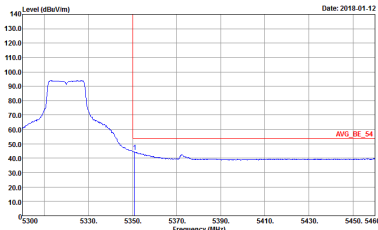

WIFI	Band 2 5250~5350MHz Band Edge @ 3m	
ANT	802.11a CH64 5320MHz	
1	Vertical	Fundamental
Peak	 <p>Site : 03CH11-HY Condition : PEAK_BE_74 3m HORN 91200-HF VERTICAL RBW:1000.000KHz VBW:3000.000KHz SWT:Auto Detector : Peak Project : 7D2018</p>	 <p>Site : 03CH11-HY Condition : PEAK_74 3m HORN 91200-HF VERTICAL RBW:1000.000KHz VBW:3000.000KHz SWT:Auto Detector : Peak Project : 7D2018</p>
Avg.	 <p>Site : 03CH11-HY Condition : AVG_BE_54 3m HORN 91200-HF VERTICAL RBW:1000.000KHz VBW:1000KHz SWT:Auto Detector : Peak Project : 7D2018</p>	Left blank

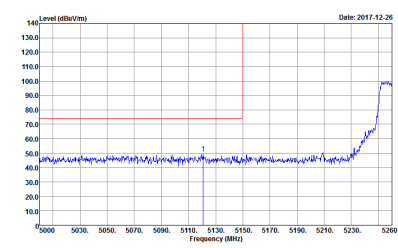
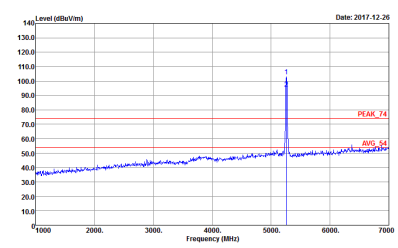
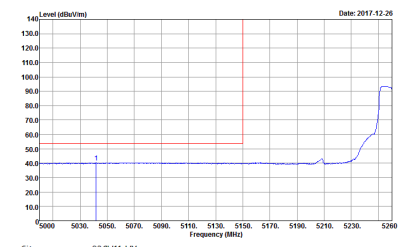

Band 2 5250~5350MHz
WIFI 802.11n HT20 (Band Edge @ 3m)

WIFI	Band 2 5250~5350MHz Band Edge @ 3m	
ANT	802.11n HT20 CH52 5260MHz - L	
1	Horizontal	Fundamental
Peak	 <p>Site : 03CH11-HY Condition : PEAK_BE_74 3m HORN 91200-HF HORIZONTAL Detector : Peak Project : 7D2018</p>	 <p>Site : 03CH11-HY Condition : PEAK_74 3m HORN 91200-HF HORIZONTAL Detector : Peak Project : 7D2018</p>
Avg.	 <p>Site : 03CH11-HY Condition : AVG_BE_54 3m HORN 91200-HF HORIZONTAL Detector : Peak Project : 7D2018</p>	Left blank

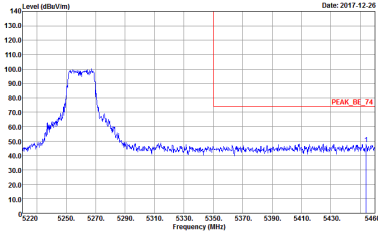
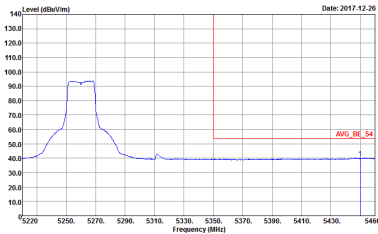

WIFI	Band 2 5250~5350MHz Band Edge @ 3m	
ANT	802.11n HT20 CH52 5260MHz - R	
1	Horizontal	Fundamental
Peak	 <p>Site : 03CH11-HY Condition : PEAK_BE_74 3m HORN 91200-HF HORIZONTAL RBW:1000.000KHz VBW:3000.000KHz SWF:Auto Detector : Peak Project : 7D2018</p>	Left blank
Avg.	 <p>Site : 03CH11-HY Condition : AVG_BE_54 3m HORN 91200-HF HORIZONTAL RBW:1000.000KHz VBW:1000KHz SWF:Auto Detector : Peak Project : 7D2018</p>	Left blank



WIFI	Band 2 5250~5350MHz Band Edge @ 3m	
ANT	802.11n HT20 CH52 5260MHz - L	
1	Vertical	Fundamental
Peak	<p>Site : 03CH11-HY Condition : PEAK_BE_74 3m HORN 91200-HF VERTICAL RBW:1000.000KHz VBW:3000.000KHz SWT:Auto Detector : Peak Project : 7D2018</p>	<p>Site : 03CH11-HY Condition : PEAK_74 3m HORN 91200-HF VERTICAL RBW:1000.000KHz VBW:3000.000KHz SWT:Auto Detector : Peak Project : 7D2018</p>
Avg.	<p>Site : 03CH11-HY Condition : AVG_BE_54 3m HORN 91200-HF VERTICAL RBW:1000.000KHz VBW:1000KHz SWT:Auto Detector : Peak Project : 7D2018</p>	Left blank

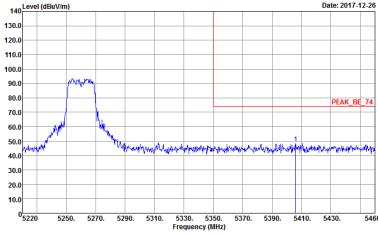
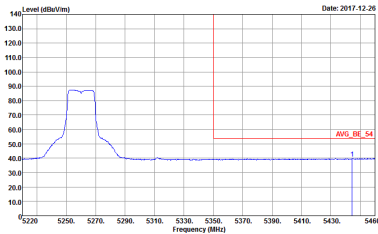

WIFI	Band 2 5250~5350MHz Band Edge @ 3m	
ANT	802.11n HT20 CH52 5260MHz - R	
1	Vertical	Fundamental
<p>Peak</p>	 <p>Site : 03CH11-HY Condition : PEAK_BE_74 3m HORN 91200-HF VERTICAL RBW:1000.000KHz VBW:3000.000KHz SWF:Auto Detector : Peak Project : 7D2018</p>	<p>Left blank</p>
<p>Avg.</p>	 <p>Site : 03CH11-HY Condition : AVG_BE_54 3m HORN 91200-HF VERTICAL RBW:1000.000KHz VBW:1.000KHz SWF:Auto Detector : Peak Project : 7D2018</p>	<p>Left blank</p>



WIFI	Band 2 5250~5350MHz Band Edge @ 3m	
ANT	802.11n HT20 CH60 5300MHz - L	
1	Horizontal	Fundamental
Peak	<p>Site : 03CH11-HY Condition : PEAK_BE_74 3m HORN 91200-HF HORIZONTAL RBW:1000.000KHz VBW:3000.000KHz SWT:Auto Detector : Peak Project : 7D2018</p>	<p>Site : 03CH11-HY Condition : PEAK_74 3m HORN 91200-HF HORIZONTAL RBW:1000.000KHz VBW:3000.000KHz SWT:Auto Detector : Peak Project : 7D2018</p>
Avg.	<p>Site : 03CH11-HY Condition : AVG_BE_54 3m HORN 91200-HF HORIZONTAL RBW:1000.000KHz VBW:1.000KHz SWT:Auto Detector : Peak Project : 7D2018</p>	Left blank

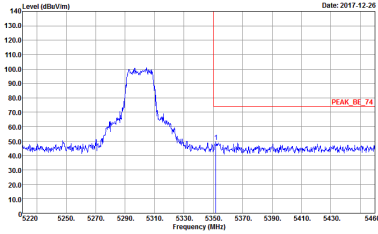
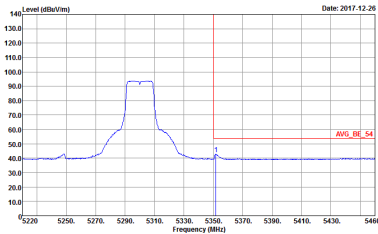

WIFI	Band 2 5250~5350MHz Band Edge @ 3m	
ANT	802.11n HT20 CH60 5300MHz - R	
1	Horizontal	Vertical
<p>Peak</p>	 <p>Site : 03CH11-HY Condition : PEAK_BE_74 3m HORN 91200-HF HORIZONTAL RBW:1000.000KHz VBW:3000.000KHz SWF:Auto Detector : Peak Project : 7D2018</p>	<p>Left blank</p>
<p>Avg.</p>	 <p>Site : 03CH11-HY Condition : AVG_BE_54 3m HORN 91200-HF HORIZONTAL RBW:1000.000KHz VBW:1.000KHz SWF:Auto Detector : Peak Project : 7D2018</p>	<p>Left blank</p>



WIFI	Band 2 5250~5350MHz Band Edge @ 3m	
ANT	802.11n HT20 CH60 5300MHz - L	
1	Vertical	Fundamental
Peak	<p> Site : 03CH11-HY Condition : PEAK_BE_74 3m HORN 91200-HF VERTICAL RBW:1000.000KHz VBW:3000.000KHz SWT:Auto Detector : Peak Project : 7D2018 </p>	<p> Site : 03CH11-HY Condition : PEAK_74 3m HORN 91200-HF VERTICAL RBW:1000.000KHz VBW:3000.000KHz SWT:Auto Detector : Peak Project : 7D2018 </p>
Avg.	<p> Site : 03CH11-HY Condition : AVG_BE_54 3m HORN 91200-HF VERTICAL RBW:1000.000KHz VBW:1000KHz SWT:Auto Detector : Peak Project : 7D2018 </p>	Left blank



WIFI	Band 2 5250~5350MHz Band Edge @ 3m	
ANT	802.11n HT20 CH60 5300MHz - R	
1	Vertical	Fundamental
Peak		Left blank
Avg.		Left blank



WIFI	Band 2 5250~5350MHz Band Edge @ 3m	
ANT	802.11n HT20 CH64 5320MHz	
1	Horizontal	Fundamental
Peak	<p>Site : 03CH11-HY Condition : PEAK_BE_74 3m HORN 91200-HF HORIZONTAL RBW:1000.000KHz VBW:3000.000KHz SWT:Auto Detector : Peak Project : 7D2018</p>	<p>Site : 03CH11-HY Condition : PEAK_74 3m HORN 91200-HF HORIZONTAL RBW:1000.000KHz VBW:3000.000KHz SWT:Auto Detector : Peak Project : 7D2018</p>
Avg.	<p>Site : 03CH11-HY Condition : AVG_BE_54 3m HORN 91200-HF HORIZONTAL RBW:1000.000KHz VBW:1000KHz SWT:Auto Detector : Peak Project : 7D2018</p>	Left blank



WIFI	Band 2 5250~5350MHz Band Edge @ 3m	
ANT	802.11n HT20 CH64 5320MHz	
1	Vertical	Fundamental
Peak	<p>Site : 03CH11-HY Condition : PEAK_BE_74 3m HORN 91200-HF VERTICAL RBW:1000.000KHz VBW:3000.000KHz SWT:Auto Detector : Peak Project : 7D2018</p>	<p>Site : 03CH11-HY Condition : PEAK_74 3m HORN 91200-HF VERTICAL RBW:1000.000KHz VBW:3000.000KHz SWT:Auto Detector : Peak Project : 7D2018</p>
Avg.	<p>Site : 03CH11-HY Condition : AVG_BE_54 3m HORN 91200-HF VERTICAL RBW:1000.000KHz VBW:1000KHz SWT:Auto Detector : Peak Project : 7D2018</p>	Left blank



Band 2 5250~5350MHz
WIFI 802.11n HT40 (Band Edge @ 3m)

WIFI	Band 2 5250~5350MHz Band Edge @ 3m	
ANT	802.11n HT40 CH54 5270MHz - L	
1	Horizontal	Fundamental
Peak	<p>Site : 03CH11-HY Condition : PEAK_BE_74 3m HORN 91200-HF HORIZONTAL Detector : Peak Project : 7D2018</p>	<p>Site : 03CH11-HY Condition : PEAK_74 3m HORN 91200-HF HORIZONTAL Detector : Peak Project : 7D2018</p>
Avg.	<p>Site : 03CH11-HY Condition : AVG_BE_54 3m HORN 91200-HF HORIZONTAL Detector : Peak Project : 7D2018</p>	Left blank

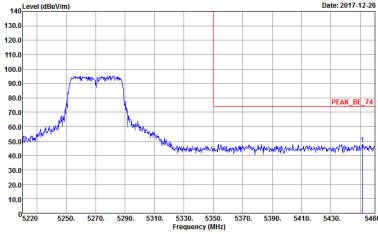
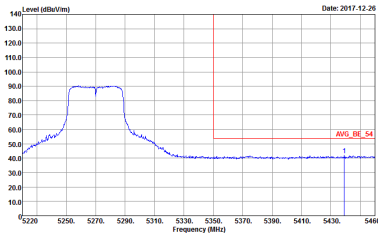

WIFI	Band 2 5250~5350MHz Band Edge @ 3m	
ANT	802.11n HT40 CH54 5270 MHz - R	
1	Horizontal	Fundamental
<p>Peak</p>	 <p>Site : 03CH11-HY Condition : PEAK_BE_74 3m HORN 91200-HF HORIZONTAL RBW:1000.000kHz VBW:3000.000kHz SWT:Auto Detector : Peak Project : 7D2018</p>	<p>Left blank</p>
<p>Avg.</p>	 <p>Site : 03CH11-HY Condition : AVG_BE_54 3m HORN 91200-HF HORIZONTAL RBW:1000.000kHz VBW:10.000kHz SWT:Auto Detector : Peak Project : 7D2018</p>	<p>Left blank</p>



WIFI	Band 2 5250~5350MHz Band Edge @ 3m	
ANT	802.11n HT40 CH54 5270 MHz - L	
1	Vertical	Vertical
Peak	<p>Site : 03CH11-HY Condition : PEAK_BE_74 3m HORN 91200-HF VERTICAL RBW:1000.000KHz VBW:3000.000KHz SWT:Auto Detector : Peak Project : 7D2018</p>	<p>Site : 03CH11-HY Condition : PEAK_74 3m HORN 91200-HF VERTICAL RBW:1000.000KHz VBW:3000.000KHz SWT:Auto Detector : Peak Project : 7D2018</p>
Avg.	<p>Site : 03CH11-HY Condition : AVG_BE_54 3m HORN 91200-HF VERTICAL RBW:1000.000KHz VBW:10.000KHz SWT:Auto Detector : Peak Project : 7D2018</p>	Left blank

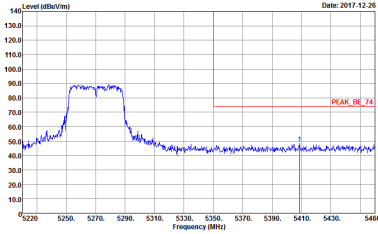
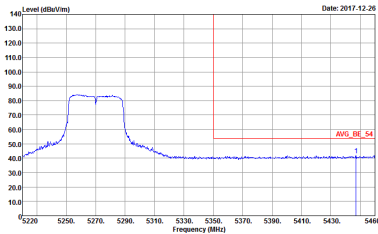

WIFI	Band 2 5250~5350MHz Band Edge @ 3m	
ANT	802.11n HT40 CH54 5270 MHz - R	
1	Vertical	Vertical
<p>Peak</p>	 <p>Site : 03CH11-HY Condition : PEAK_BE_74 3m HORN 91200-HF VERTICAL RBW:1000.000KHz VBW:3000.000KHz SWT:Auto Detector : Peak Project : 7D2018</p>	<p>Left blank</p>
<p>Avg.</p>	 <p>Site : 03CH11-HY Condition : AVG_BE_54 3m HORN 91200-HF VERTICAL RBW:1000.000KHz VBW:10.000KHz SWT:Auto Detector : Peak Project : 7D2018</p>	<p>Left blank</p>



WIFI	Band 2 5250~5350MHz Band Edge @ 3m	
ANT	802.11n HT40 CH62 5310 MHz - L	
1	Horizontal	Fundamental
Peak	<p>Site : 03CH11-HY Condition : PEAK_BE_74 3m HORN 91200-HF HORIZONTAL RBW:1000.000KHz VBW:3000.000KHz SWT:Auto Detector : Peak Project : 7D2018</p>	<p>Site : 03CH11-HY Condition : PEAK_74 3m HORN 91200-HF HORIZONTAL RBW:1000.000KHz VBW:3000.000KHz SWT:Auto Detector : Peak Project : 7D2018</p>
Avg.	<p>Site : 03CH11-HY Condition : AVG_BE_54 3m HORN 91200-HF HORIZONTAL RBW:1000.000KHz VBW:10.000KHz SWT:Auto Detector : Peak Project : 7D2018</p>	Left blank

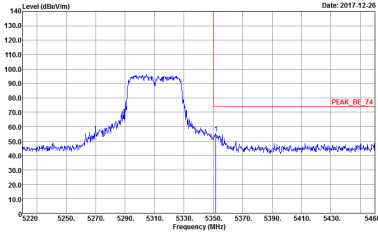
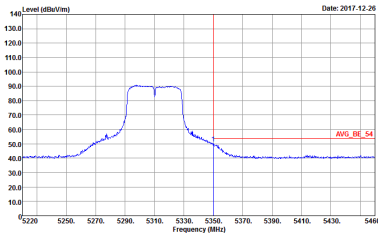

WIFI	Band 2 5250~5350MHz Band Edge @ 3m	
ANT	802.11n HT40 CH62 5310 MHz - R	
1	Horizontal	Fundamental
Peak	 <p>Site : 03CH11-HY Condition : PEAK_BE_74 3m HORN 91200-HF HORIZONTAL RBW:1000.000kHz VBW:3000.000kHz SWT:Auto Detector : Peak Project : 7D2018</p>	Left blank
Avg.	 <p>Site : 03CH11-HY Condition : AVG_BE_54 3m HORN 91200-HF HORIZONTAL RBW:1000.000kHz VBW:10.000kHz SWT:Auto Detector : Peak Project : 7D2018</p>	Left blank



WIFI	Band 2 5250~5350MHz Band Edge @ 3m	
ANT	802.11n HT40 CH62 5310 MHz - L	
1	Vertical	Fundamental
Peak	<p>Site : 03CH11-HY Condition : PEAK_BE_74 3m HORN 91200-HF VERTICAL RBW:1000.000KHz VBW:3000.000KHz SWT:Auto Detector : Peak Project : 7D2018</p>	<p>Site : 03CH11-HY Condition : PEAK_74 3m HORN 91200-HF VERTICAL RBW:1000.000KHz VBW:3000.000KHz SWT:Auto Detector : Peak Project : 7D2018</p>
Avg.	<p>Site : 03CH11-HY Condition : AVG_BE_54 3m HORN 91200-HF VERTICAL RBW:1000.000KHz VBW:10.000KHz SWT:Auto Detector : Peak Project : 7D2018</p>	Left blank

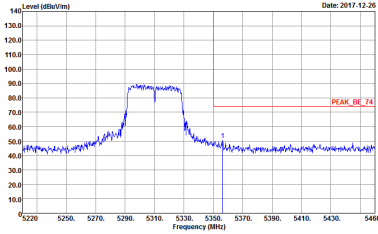
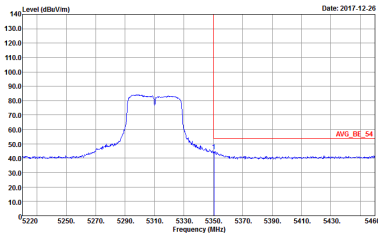

WIFI	Band 2 5250~5350MHz Band Edge @ 3m	
ANT	802.11n HT40 CH62 5310 MHz - R	
1	Vertical	Fundamental
<p>Peak</p>	 <p>Site : 03CH11-HY Condition : PEAK_BE_74 3m HORN 91200-HF VERTICAL RBW:1000.000kHz VBW:3000.000kHz SWT:Auto Detector : Peak Project : 7D2018</p>	<p>Left blank</p>
<p>Avg.</p>	 <p>Site : 03CH11-HY Condition : AVG_BE_54 3m HORN 91200-HF VERTICAL RBW:1000.000kHz VBW:10.000kHz SWT:Auto Detector : Peak Project : 7D2018</p>	<p>Left blank</p>



Band 2 - 5250~5350MHz
WIFI 802.11a (Harmonic @ 3m)

WIFI	Band 2 5250~5350MHz Harmonic @ 3m	
ANT	802.11a CH52 5260MHz	
1	Horizontal	Vertical
Peak Avg.	<p>Site : 03CH11-FY Condition : PEAK_74 3m HORN 9120D-HF HORIZONTAL Project : 7D2018</p>	<p>Site : 03CH11-FY Condition : PEAK_74 3m HORN 9120D-HF VERTICAL Project : 7D2018</p>

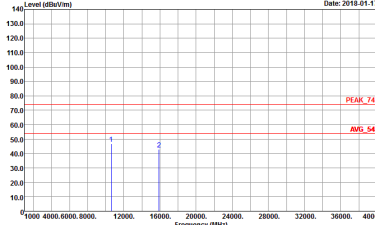
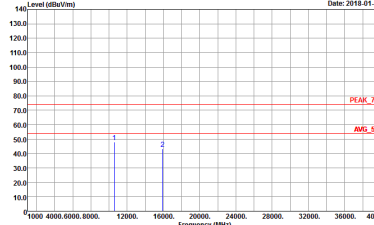

WIFI	Band 2 5250~5350MHz Harmonic @ 3m	
ANT	802.11a CH60 5300MHz	
1	Horizontal	Vertical
<p>Peak</p> <p>Avg.</p>	 <p>Site : 03CH11-HY Condition : PEAK_74 3m HORN 9120D-HF HORIZONTAL Project : 7D2018</p>	 <p>Site : 03CH11-HY Condition : PEAK_74 3m HORN 9120D-HF VERTICAL Project : 7D2018</p>



WIFI	Band 2 5250~5350MHz Harmonic @ 3m	
ANT	802.11a CH64 5320MHz	
1	Horizontal	Vertical
Peak Avg.	<p>Site : 03CH11-HY Condition : PEAK_74 3m HORN 9120D-HF VERTICAL Project : 7D2018</p>	<p>Site : 03CH11-HY Condition : PEAK_74 3m HORN 9120D-HF VERTICAL Project : 7D2018</p>



Band 2 5250~5350MHz
WIFI 802.11n HT20 (Harmonic @ 3m)

WIFI	Band 2 5250~5350MHz Harmonic @ 3m	
ANT	802.11n HT20 CH52 5260MHz	
1	Horizontal	Vertical
Peak Avg.	<p>Site : 03GH11-HY Condition : PEAK_74 3m HORN 9120D-HF HORIZONTAL Project : 7D2018</p>	<p>Site : 03GH11-HY Condition : PEAK_74 3m HORN 9120D-HF VERTICAL Project : 7D2018</p>



WIFI	Band 2 5250~5350MHz Harmonic @ 3m	
ANT	802.11n HT20 CH60 5300MHz	
1	Horizontal	Vertical
Peak Avg.	<p>Site : 03CH11-HY Condition : PEAK_74 3m HORN 9120D-HF HORIZONTAL Project : 7D2018</p>	<p>Site : 03CH11-HY Condition : PEAK_74 3m HORN 9120D-HF VERTICAL Project : 7D2018</p>



WIFI	Band 2 5250~5350MHz Harmonic @ 3m	
ANT	802.11n HT20 CH64 5320MHz	
1	Horizontal	Vertical
Peak Avg.	<p>Site : 03CH11-HY Condition : PEAK_74 3m HORN 9120D-HF HORIZONTAL Project : 7D2018</p>	<p>Site : 03CH11-HY Condition : PEAK_74 3m HORN 9120D-HF VERTICAL Project : 7D2018</p>



**Band 2 5250~5350MHz
WIFI 802.11n HT40 (Harmonic @ 3m)**

WIFI	Band 2 5250~5350MHz Harmonic @ 3m	
ANT	802.11n HT40 CH54 5270MHz	
1	Horizontal	Vertical
Peak Avg.	<p>Site : 03GH11-HY Condition : PEAK_74 3m HORN 9120D-HF HORIZONTAL Project : 7D2018</p>	<p>Site : 03GH11-HY Condition : PEAK_74 3m HORN 9120D-HF VERTICAL Project : 7D2018</p>



WIFI	Band 2 5250~5350MHz Harmonic @ 3m	
ANT	802.11n HT40 CH62 5310MHz	
1	Horizontal	Vertical
Peak Avg.	<p>Site : 03CH11-HY Condition : PEAK_74 3m HORN 9120D-HF HORIZONTAL Project : 7D2018</p>	<p>Site : 03CH11-HY Condition : PEAK_74 3m HORN 9120D-HF VERTICAL Project : 7D2018</p>

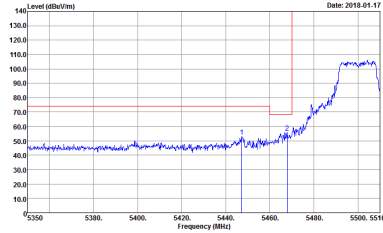
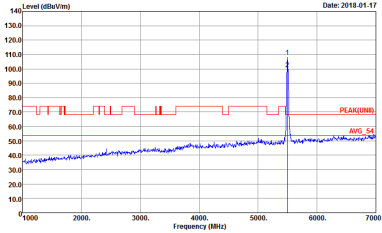
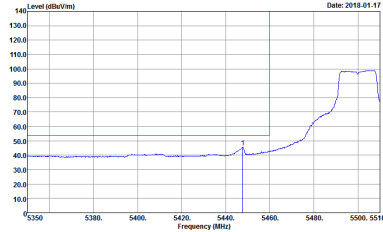

Band 3 - 5470~5725MHz
WIFI 802.11a (Band Edge @ 3m)

WIFI	Band 3 5470~5725MHz Band Edge @ 3m	
ANT	802.11a CH100 5500MHz	
1	Horizontal	Fundamental
Peak	 <p>Site : 03CH11-HY Condition : PEAK_BE(UNIT)_B3 3m HORN 9120D-HF HORIZONTAL Detector : Peak Project : 7D2018</p>	 <p>Site : 03CH11-HY Condition : PEAK(UNIT) 3m HORN 9120D-HF HORIZONTAL Detector : Peak Project : 7D2018</p>
Avg.	 <p>Site : 03CH11-HY Condition : AVG_BE(UNIT)_B3 3m HORN 9120D-HF HORIZONTAL Detector : Peak Project : 7D2018</p>	Left blank

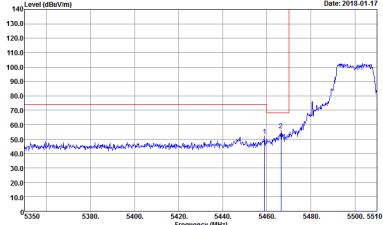
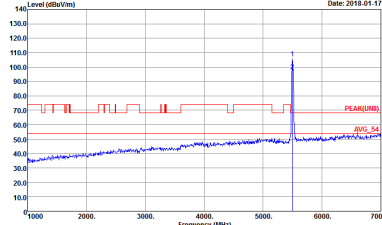
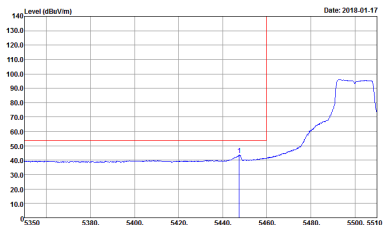

WIFI	Band 3 5470~5725MHz Band Edge @ 3m	
ANT	802.11a CH100 5500MHz	
1	Vertical	Fundamental
Peak	 <p>Site : 03CH11-HY Condition : PEAK_BE[UNII]_B3 3m HORN 9120D-HF VERTICAL RBW:1000.000KHz VBW:3000.000KHz SWT:Auto Detector : Peak Project : 7D2018</p>	 <p>Site : 03CH11-HY Condition : PEAK[UNII] 3m HORN 9120D-HF VERTICAL RBW:1000.000KHz VBW:3000.000KHz SWT:Auto Detector : Peak Project : 7D2018</p>
Avg.	 <p>Site : 03CH11-HY Condition : AVG_BE[UNII]_B3 3m HORN 9120D-HF VERTICAL RBW:1000.000KHz VBW:1.000KHz SWT:Auto Detector : Peak Project : 7D2018</p>	Left blank



WIFI	Band 3 5470~5725MHz Band Edge @ 3m	
ANT	802.11a CH116 5580MHz - L	
1	Horizontal	Fundamental
Peak	<p>Site : 03CH11-HY Condition : PEAK_BE(UNII)_B3 3m HORN 9120D-HF HORIZONTAL RBW:1000.000KHz VBW:3000.000KHz SWT:Auto Detector : Peak Project : 7D2018</p>	<p>Site : 03CH11-HY Condition : PEAK(UNII) 3m HORN 9120D-HF HORIZONTAL RBW:1000.000KHz VBW:3000.000KHz SWT:Auto Detector : Peak Project : 7D2018</p>
Avg.	<p>Site : 03CH11-HY Condition : AVG_BE(UNII)_B3 3m HORN 9120D-HF HORIZONTAL RBW:1000.000KHz VBW:1.000KHz SWT:Auto Detector : Peak Project : 7D2018</p>	Left blank



WIFI	Band 3 5470~5725MHz Band Edge @ 3m	
ANT	802.11a CH116 5580MHz - R	
1	Horizontal	Fundamental
Peak	<p>Site : 03CH11-HY Condition : PEAK_BE(UNIT)_B3 3m HORN 91200-HF HORIZONTAL Detector : Peak Project : 7D2018</p>	Left blank



WIFI	Band 3 5470~5725MHz Band Edge @ 3m	
ANT	802.11a CH116 5580MHz - L	
1	Vertical	Fundamental
Peak	<p>Site : 03CH11-HY Condition : PEAK_BE(UNII)_B3 3m HORN 9120D-HF VERTICAL RBW:1000.000KHz VBW:3000.000KHz SWT:Auto Detector : Peak Project : 7D2018</p>	<p>Site : 03CH11-HY Condition : PEAK(UNII) 3m HORN 9120D-HF VERTICAL RBW:1000.000KHz VBW:3000.000KHz SWT:Auto Detector : Peak Project : 7D2018</p>
Avg.	<p>Site : 03CH11-HY Condition : AVG_BE(UNII)_B3 3m HORN 9120D-HF VERTICAL RBW:1000.000KHz VBW:1.000KHz SWT:Auto Detector : Peak Project : 7D2018</p>	Left blank



WIFI	Band 3 5470~5725MHz Band Edge @ 3m	
ANT	802.11a CH116 5580MHz - R	
1	Vertical	Fundamental
Peak	<p>Site : 03CH11-HY Condition : PEAK_BE(UNIT)_B3 3m HORN 91200-HF VERTICAL RBW:1000.000KHz VBW:3000.000KHz SWT:Auto Detector : Peak Project : 7D2018</p>	Left blank



WIFI	Band 3 5470~5725MHz Band Edge @ 3m	
ANT	802.11a CH140 5700MHz	
1	Horizontal	Fundamental
Peak	<p>Site : 03CH11-HY Condition : PEAK_BE[UNII]_B3 3m HORN 9120D-HF HORIZONTAL RBW:1000.000KHz VBW:3000.000KHz SWT:Auto Detector : Peak Project : 7D2018</p>	<p>Site : 03CH11-HY Condition : PEAK[UNII] 3m HORN 9120D-HF HORIZONTAL RBW:1000.000KHz VBW:3000.000KHz SWT:Auto Detector : Peak Project : 7D2018</p>



WIFI	Band 3 5470~5725MHz Band Edge @ 3m	
ANT	802.11a CH140 5700MHz	
1	Vertical	Fundamental
Peak	<p> Site : 03CH11-HY Condition : PEAK_BE(UNII)_B3 3m HORN 91200-HF VERTICAL RBW:1000.000KHz VBW:3000.000KHz SWT:Auto Detector : Peak Project : 7D2018 </p>	<p> Site : 03CH11-HY Condition : PEAK(UNII) 3m HORN 91200-HF VERTICAL RBW:1000.000KHz VBW:3000.000KHz SWT:Auto Detector : Peak Project : 7D2018 </p>



Band 3 5470~5725MHz
WIFI 802.11n HT20 (Band Edge @ 3m)

Table with 2 columns (WIFI, ANT) and 2 rows (Peak, Avg.). It contains spectral analysis graphs for Horizontal and Fundamental components, showing Level (dBu/m) vs Frequency (MHz) with various annotations like 'PEAK_74' and 'AVG_54'.



WIFI	Band 3 5470~5725MHz Band Edge @ 3m	
ANT	802.11n HT20 CH100 5500MHz	
1	Vertical	Fundamental
Peak	<p>Site : 03CH11-HY Condition : PEAK_BE_74 3m HORN 91200-HF VERTICAL RBW:1000.000KHz VBW:3000.000KHz SWT:Auto Detector : Peak Project : 7D2018</p>	<p>Site : 03CH11-HY Condition : PEAK_74 3m HORN 91200-HF VERTICAL RBW:1000.000KHz VBW:3000.000KHz SWT:Auto Detector : Peak Project : 7D2018</p>
Avg.	<p>Site : 03CH11-HY Condition : AVG_BE_54 3m HORN 91200-HF VERTICAL RBW:1000.000KHz VBW:1000KHz SWT:Auto Detector : Peak Project : 7D2018</p>	Left blank



WIFI	Band 3 5470~5725MHz Band Edge @ 3m	
ANT	802.11n HT20 CH116 5580MHz - L	
1	Horizontal	Fundamental
Peak	<p>Site : 03CH11-HY Condition : PEAK_BE_74 3m HORN 91200-HF HORIZONTAL RBW:1000.000KHz VBW:3000.000KHz SWT:Auto Detector : Peak Project : 7D2018</p>	<p>Site : 03CH11-HY Condition : PEAK_74 3m HORN 91200-HF HORIZONTAL RBW:1000.000KHz VBW:3000.000KHz SWT:Auto Detector : Peak Project : 7D2018</p>
Avg.	<p>Site : 03CH11-HY Condition : AVG_BE_54 3m HORN 91200-HF HORIZONTAL RBW:1000.000KHz VBW:1000KHz SWT:Auto Detector : Peak Project : 7D2018</p>	Left blank

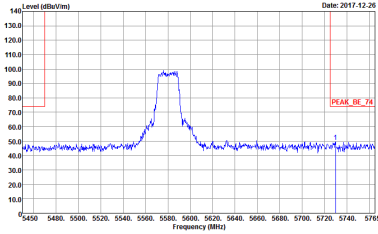
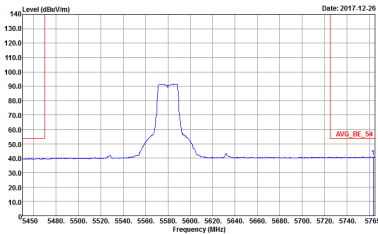

WIFI	Band 3 5470~5725MHz Band Edge @ 3m	
ANT	802.11n HT20 CH116 5580MHz - R	
1	Horizontal	Fundamental
<p>Peak</p>	 <p>Site : 03CH11-HY Condition : PEAK_BE_74 3m HORN 91200-HF HORIZONTAL RBW:1000.000KHz VBW:3000.000KHz SWF:Auto Detector : Peak Project : 7D2018</p>	<p>Left blank</p>
<p>Avg.</p>	 <p>Site : 03CH11-HY Condition : AVG_BE_54 3m HORN 91200-HF HORIZONTAL RBW:1000.000KHz VBW:1.000KHz SWF:Auto Detector : Peak Project : 7D2018</p>	<p>Left blank</p>



WIFI	Band 3 5470~5725MHz Band Edge @ 3m	
ANT	802.11n HT20 CH116 5580MHz - L	
1	Vertical	Fundamental
Peak	<p>Site : 03CH11-HY Condition : PEAK_BE_74 3m HORN 91200-HF VERTICAL RBW:1000.000KHz VBW:3000.000KHz SWT:Auto Detector : Peak Project : 7D2018</p>	<p>Site : 03CH11-HY Condition : PEAK_74 3m HORN 91200-HF VERTICAL RBW:1000.000KHz VBW:3000.000KHz SWT:Auto Detector : Peak Project : 7D2018</p>
Avg.	<p>Site : 03CH11-HY Condition : AVG_BE_54 3m HORN 91200-HF VERTICAL RBW:1000.000KHz VBW:1000KHz SWT:Auto Detector : Peak Project : 7D2018</p>	Left blank

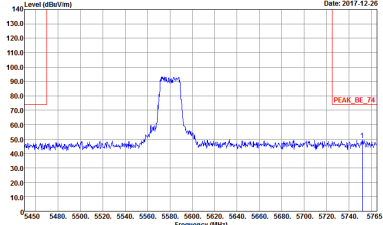
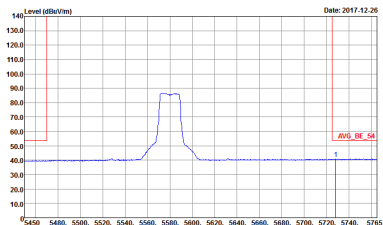

WIFI	Band 3 5470~5725MHz Band Edge @ 3m	
ANT	802.11n HT20 CH116 5580MHz - R	
1	Vertical	Fundamental
Peak	 <p>Site : 03CH11-HY Condition : PEAK_BE_74 3m HORN 91200-HF VERTICAL RBW:1000.000KHz VBW:3000.000KHz SWF:Auto Detector : Peak Project : 7D2018</p>	Left blank
Avg.	 <p>Site : 03CH11-HY Condition : AVG_BE_54 3m HORN 91200-HF VERTICAL RBW:1000.000KHz VBW:1.000KHz SWF:Auto Detector : Peak Project : 7D2018</p>	Left blank

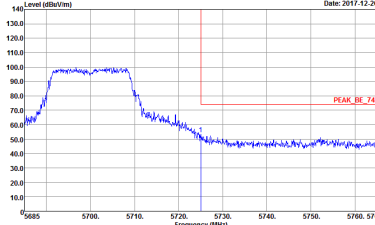
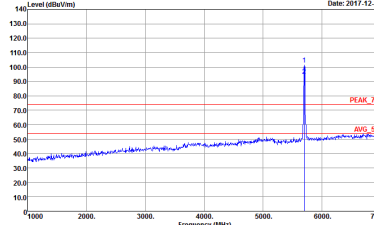
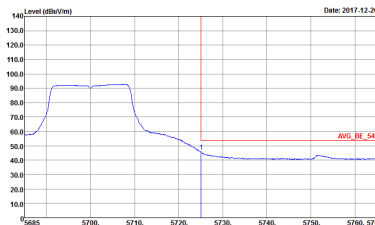

WIFI	Band 3 5470~5725MHz Band Edge @ 3m	
ANT	802.11n HT20 CH140 5700MHz	
1	Horizontal	Fundamental
Peak	 <p>Site : 03CH11-HY Condition : PEAK_BE_74 3m HORN 91200-HF HORIZONTAL RBW:1000.000KHz VBW:3000.000KHz SWT:Auto Detector : Peak Project : 7D2018</p>	 <p>Site : 03CH11-HY Condition : PEAK_74 3m HORN 91200-HF HORIZONTAL RBW:1000.000KHz VBW:3000.000KHz SWT:Auto Detector : Peak Project : 7D2018</p>
Avg.	 <p>Site : 03CH11-HY Condition : AVG_BE_54 3m HORN 91200-HF HORIZONTAL RBW:1000.000KHz VBW:1000KHz SWT:Auto Detector : Peak Project : 7D2018</p>	Left blank



WIFI	Band 3 5470~5725MHz Band Edge @ 3m	
ANT	802.11n HT20 CH140 5700MHz	
1	Vertical	Fundamental
Peak.	<p>Site : 03CH11-HY Condition : PEAK_BE_74 3m HORN 91200-HF VERTICAL RBW:1000.000KHz VBW:3000.000KHz SWT:Auto Detector : Peak Project : 7D2018</p>	<p>Site : 03CH11-HY Condition : PEAK_74 3m HORN 91200-HF VERTICAL RBW:1000.000KHz VBW:3000.000KHz SWT:Auto Detector : Peak Project : 7D2018</p>
Avg.	<p>Site : 03CH11-HY Condition : AVG_BE_54 3m HORN 91200-HF VERTICAL RBW:1000.000KHz VBW:1000KHz SWT:Auto Detector : Peak Project : 7D2018</p>	Left blank



Band 3 5470~5725MHz
WIFI 802.11n HT40 (Band Edge @ 3m)

WIFI	Band 3 5470~5725MHz Band Edge @ 3m	
ANT	802.11n HT40 CH102 5510MHz - L	
1	Horizontal	Fundamental
Peak	<p>Site : 03CH11-HY Condition : PEAK_BE_74 3m HORN 91200-HF HORIZONTAL Detector : Peak Project : 7D2018</p>	<p>Site : 03CH11-HY Condition : PEAK_74 3m HORN 91200-HF HORIZONTAL Detector : Peak Project : 7D2018</p>
Avg.	<p>Site : 03CH11-HY Condition : AVG_BE_54 3m HORN 91200-HF HORIZONTAL Detector : Peak Project : 7D2018</p>	Left blank

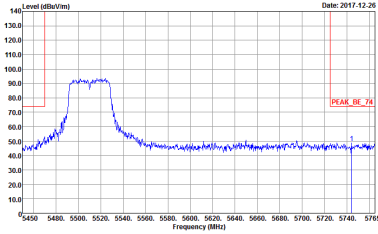
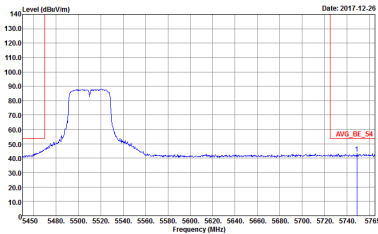

WIFI	Band 3 5470~5725MHz Band Edge @ 3m	
ANT	802.11n HT40 CH102 5510MHz - R	
1	Horizontal	Fundamental
Peak	 <p>Site : 03CH11-HY Condition : PEAK_BE_74 3m HORN 91200-HF HORIZONTAL RBW:1000.000kHz VBW:3000.000kHz SWT:Auto Detector : Peak Project : 7D2018</p>	Left blank
Avg.	 <p>Site : 03CH11-HY Condition : AVG_BE_54 3m HORN 91200-HF HORIZONTAL RBW:1000.000kHz VBW:10.000kHz SWT:Auto Detector : Peak Project : 7D2018</p>	Left blank

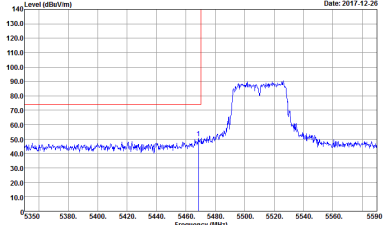
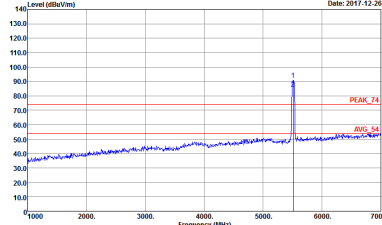
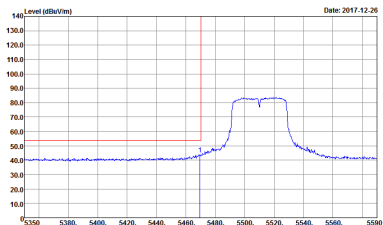

WIFI	Band 3 5470~5725MHz Band Edge @ 3m	
ANT	802.11n HT40 CH102 5510MHz - L	
1	Vertical	Fundamental
Peak	 <p>Site : 03CH11-HY Condition : PEAK_BE_74 3m HORN 91200-HF VERTICAL RBW:1000.000KHz VBW:3000.000KHz SWT:Auto Detector : Peak Project : 7D2018</p>	 <p>Site : 03CH11-HY Condition : PEAK_74 3m HORN 91200-HF VERTICAL RBW:1000.000KHz VBW:3000.000KHz SWT:Auto Detector : Peak Project : 7D2018</p>
Avg.	 <p>Site : 03CH11-HY Condition : AVG_BE_54 3m HORN 91200-HF VERTICAL RBW:1000.000KHz VBW:10.000KHz SWT:Auto Detector : Peak Project : 7D2018</p>	Left blank

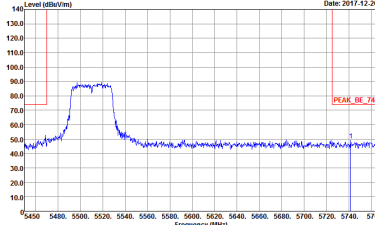
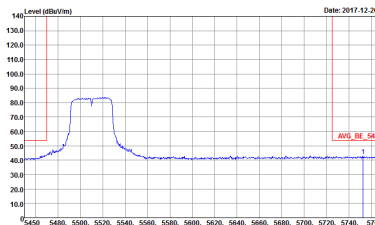

WIFI	Band 3 5470~5725MHz Band Edge @ 3m	
ANT	802.11n HT40 CH102 5510MHz - R	
1	Vertical	Fundamental
Peak	 <p>Site : 03CH11-HY Condition : PEAK_BE_74 3m HORN 91200-HF VERTICAL RBW:1000.000kHz VBW:3000.000kHz SWT:Auto Detector : Peak Project : 7D2018</p>	Left blank
Avg.	 <p>Site : 03CH11-HY Condition : AVG_BE_54 3m HORN 91200-HF VERTICAL RBW:1000.000kHz VBW:10.000kHz SWT:Auto Detector : Peak Project : 7D2018</p>	Left blank

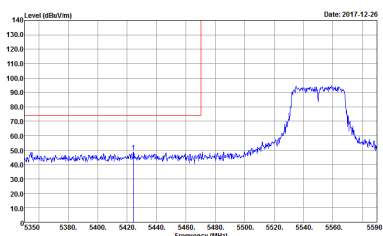
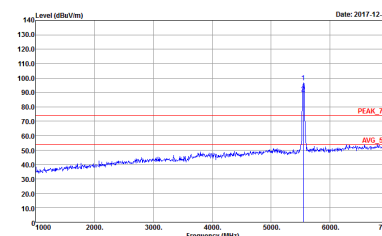
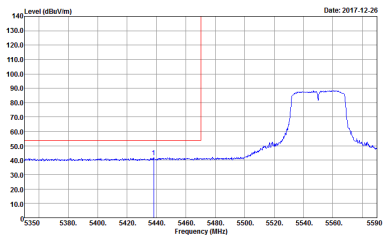

WIFI	Band 3 5470~5725MHz Band Edge @ 3m	
ANT	802.11n HT40 CH110 5550MHz - L	
1	Horizontal	Fundamental
Peak	 <p>Site : 03CH11-HY Condition : PEAK_BE_74 3m HORN 91200-HF HORIZONTAL RBW:1000.000KHz VBW:3000.000KHz SWT:Auto Detector : Peak Project : 7D2018</p>	 <p>Site : 03CH11-HY Condition : PEAK_74 3m HORN 91200-HF HORIZONTAL RBW:1000.000KHz VBW:3000.000KHz SWT:Auto Detector : Peak Project : 7D2018</p>
Avg.	 <p>Site : 03CH11-HY Condition : AVG_BE_54 3m HORN 91200-HF HORIZONTAL RBW:1000.000KHz VBW:10.000KHz SWT:Auto Detector : Peak Project : 7D2018</p>	Left blank

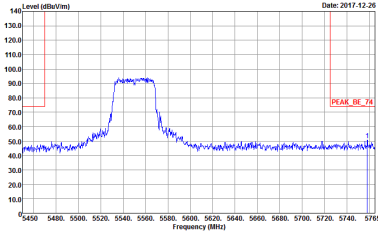
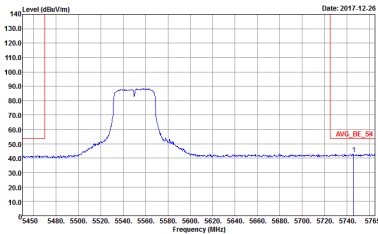

WIFI	Band 3 5470~5725MHz Band Edge @ 3m	
ANT	802.11n HT40 CH110 5550MHz - R	
1	Horizontal	Fundamental
Peak	 <p>Site : 03CH11-HY Condition : PEAK_BE_74 3m HORN 91200-HF HORIZONTAL RBW:1000.000KHz VBW:3000.000KHz SWT:Auto Detector : Peak Project : 7D2018</p>	Left blank
Avg.	 <p>Site : 03CH11-HY Condition : AVG_BE_54 3m HORN 91200-HF HORIZONTAL RBW:1000.000KHz VBW:10.000KHz SWT:Auto Detector : Peak Project : 7D2018</p>	Left blank

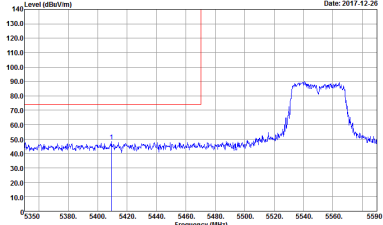
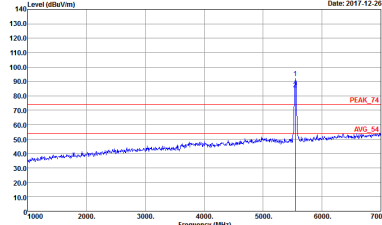
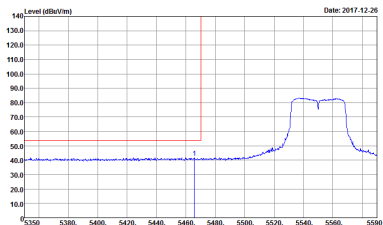

WIFI	Band 3 5470~5725MHz Band Edge @ 3m	
ANT	802.11n HT40 CH110 5550MHz - L	
1	Vertical	Fundamental
Peak	 <p>Site : 03CH11-HY Condition : PEAK_BE_74 3m HORN 91200-HF VERTICAL RBW:1000.000KHz VBW:3000.000KHz SWT:Auto Detector : Peak Project : 7D2018</p>	 <p>Site : 03CH11-HY Condition : PEAK_74 3m HORN 91200-HF VERTICAL RBW:1000.000KHz VBW:3000.000KHz SWT:Auto Detector : Peak Project : 7D2018</p>
Avg.	 <p>Site : 03CH11-HY Condition : AVG_BE_54 3m HORN 91200-HF VERTICAL RBW:1000.000KHz VBW:10.000KHz SWT:Auto Detector : Peak Project : 7D2018</p>	Left blank

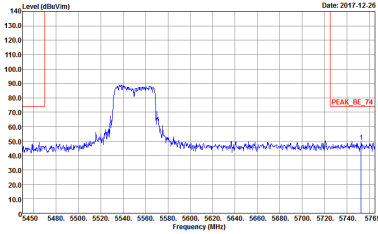
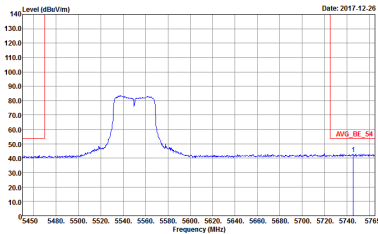

WIFI	Band 3 5470~5725MHz Band Edge @ 3m	
ANT	802.11n HT40 CH110 5550MHz - R	
1	Vertical	Fundamental
Peak	 <p>Site : 03CH11-HY Condition : PEAK_BE_74 3m HORN 91200-HF VERTICAL RBW:1000.000KHz VBW:3000.000KHz SWT:Auto Detector : Peak Project : 7D2018</p>	Left blank
Avg.	 <p>Site : 03CH11-HY Condition : AVG_BE_54 3m HORN 91200-HF VERTICAL RBW:1000.000KHz VBW:10.000KHz SWT:Auto Detector : Peak Project : 7D2018</p>	Left blank

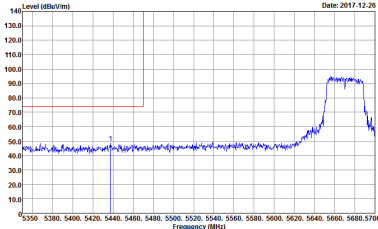
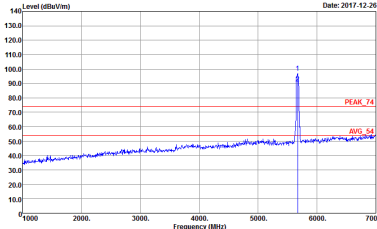
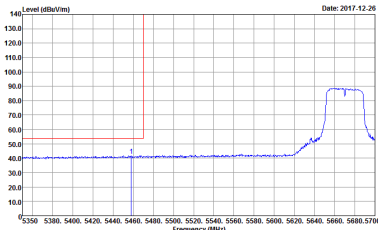

WIFI	Band 3 5470~5725MHz Band Edge @ 3m	
ANT	802.11n HT40 CH134 5670MHz - L	
1	Horizontal	Fundamental
Peak	 <p>Level (dBuV/m) vs Frequency (MHz) plot showing a peak at approximately 5670 MHz. The y-axis ranges from 10.0 to 140.0 dBuV/m, and the x-axis ranges from 5350 to 5710 MHz. A red line indicates the peak level at approximately 130 dBuV/m.</p> <p>Site : 03CH11-HY Condition : PEAK_BE_74 3m HORN 91200-HF HORIZONTAL RBW:1000.000KHz VBW:3000.000KHz SWT:Auto Detector : Peak Project : 7D2018</p>	 <p>Level (dBuV/m) vs Frequency (MHz) plot showing a peak at approximately 5670 MHz. The y-axis ranges from 10.0 to 140.0 dBuV/m, and the x-axis ranges from 0 to 7000 MHz. A red line indicates the peak level at approximately 130 dBuV/m.</p> <p>Site : 03CH11-HY Condition : PEAK_74 3m HORN 91200-HF HORIZONTAL RBW:1000.000KHz VBW:3000.000KHz SWT:Auto Detector : Peak Project : 7D2018</p>
Avg.	 <p>Level (dBuV/m) vs Frequency (MHz) plot showing the average signal for the horizontal polarization. The y-axis ranges from 10.0 to 140.0 dBuV/m, and the x-axis ranges from 5350 to 5710 MHz. A red line indicates the average level at approximately 130 dBuV/m.</p> <p>Site : 03CH11-HY Condition : AVG_BE_54 3m HORN 91200-HF HORIZONTAL RBW:1000.000KHz VBW:10.000KHz SWT:Auto Detector : Peak Project : 7D2018</p>	Left blank

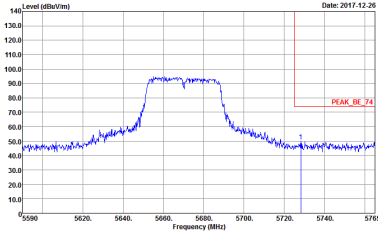
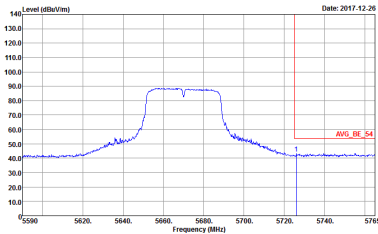

WIFI	Band 3 5470~5725MHz Band Edge @ 3m	
ANT	802.11n HT40 CH134 5670MHz - R	
1	Horizontal	Fundamental
Peak	 <p>Site : 03CH11-HY Condition : PEAK_BE_74 3m HORN 91200-HF HORIZONTAL RBW:1000.000kHz VBW:3000.000kHz SWT:Auto Detector : Peak Project : 7D2018</p>	Left blank
Avg.	 <p>Site : 03CH11-HY Condition : AVG_BE_54 3m HORN 91200-HF HORIZONTAL RBW:1000.000kHz VBW:10.000kHz SWT:Auto Detector : Peak Project : 7D2018</p>	Left blank



WIFI	Band 3 5470~5725MHz Band Edge @ 3m	
ANT	802.11n HT40 CH134 5670MHz - L	
1	Vertical	Fundamental
Peak	<p>Site : 03CH11-HY Condition : PEAK_BE_74 3m HORN 91200-HF VERTICAL RBW:1000.000KHz VBW:3000.000KHz SWT:Auto Detector : Peak Project : 7D2018</p>	<p>Site : 03CH11-HY Condition : PEAK_74 3m HORN 91200-HF VERTICAL RBW:1000.000KHz VBW:3000.000KHz SWT:Auto Detector : Peak Project : 7D2018</p>
Avg.	<p>Site : 03CH11-HY Condition : AVG_BE_54 3m HORN 91200-HF VERTICAL RBW:1000.000KHz VBW:10.000KHz SWT:Auto Detector : Peak Project : 7D2018</p>	Left blank

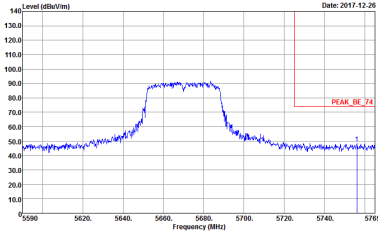
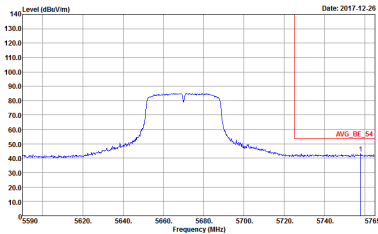

WIFI	Band 3 5470~5725MHz Band Edge @ 3m	
ANT	802.11n HT40 CH134 5670MHz - R	
1	Vertical	Fundamental
Peak	 <p>Site : 03CH11-HY Condition : PEAK_BE_74 3m HORN 91200-HF VERTICAL RBW:1000.000KHz VBW:3000.000KHz SWT:Auto Detector : Peak Project : 7D2018</p>	Left blank
Avg.	 <p>Site : 03CH11-HY Condition : AVG_BE_54 3m HORN 91200-HF VERTICAL RBW:1000.000KHz VBW:10.000KHz SWT:Auto Detector : Peak Project : 7D2018</p>	Left blank



Band 3 - 5470~5725MHz
WIFI 802.11a (Harmonic @ 3m)

WIFI	Band 3 5470~5725MHz Harmonic @ 3m	
ANT	802.11a CH100 5500MHz	
1	Horizontal	Vertical
<p>Peak</p> <p>Avg.</p>	<p>Site : 03CH11-FY Condition : PEAK(UNII) 3m HORN 9120D-HF HORIZONTAL Project : 7D2018</p>	<p>Site : 03CH11-FY Condition : PEAK(UNII) 3m HORN 9120D-HF VERTICAL Project : 7D2018</p>

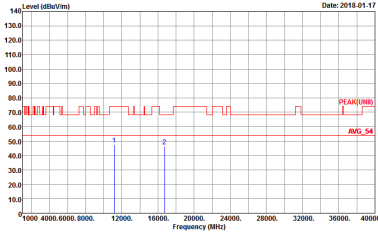
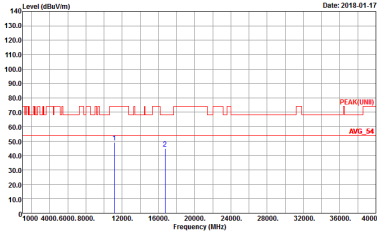

WIFI	Band 3 5470~5725MHz Harmonic @ 3m	
ANT	802.11a CH116 5580MHz	
1	Horizontal	Vertical
<p>Peak</p> <p>Avg.</p>	 <p>Site : 03CH11-HY Condition : PEAK(UNII) 3m HORN 9120D-HF HORIZONTAL Project : 7D2018</p>	 <p>Site : 03CH11-HY Condition : PEAK(UNII) 3m HORN 9120D-HF VERTICAL Project : 7D2018</p>

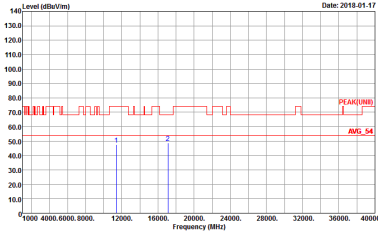
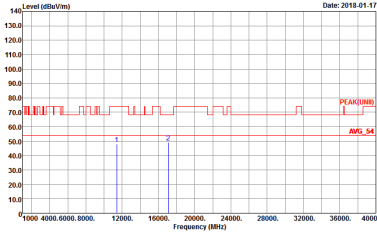

WIFI	Band 3 5470~5725MHz Harmonic @ 3m	
ANT	802.11a CH140 5700MHz	
1	Horizontal	Vertical
<p>Peak</p> <p>Avg.</p>	 <p>Site : 03CH11-HY Condition : PEAK(UNII) 3m HORN 9120D-HF HORIZONTAL Project : 7D2018</p>	 <p>Site : 03CH11-HY Condition : PEAK(UNII) 3m HORN 9120D-HF VERTICAL Project : 7D2018</p>



**Band 3 5470~5725MHz
WIFI 802.11n HT20 (Harmonic @ 3m)**

WIFI	Band 3 5470~5725MHz Harmonic @ 3m	
ANT	802.11n HT20 CH100 5500MHz	
1	Horizontal	Vertical
Peak Avg.	<p>Site : 03GH11-HY Condition : PEAK_74 3m HORN 9120D-HF HORIZONTAL Project : 7D2018</p>	<p>Site : 03GH11-HY Condition : PEAK_74 3m HORN 9120D-HF VERTICAL Project : 7D2018</p>



WIFI	Band 3 5470~5725MHz Harmonic @ 3m	
ANT	802.11n HT20 CH116 5580MHz	
1	Horizontal	Vertical
Peak Avg.	<p>Site : 03CH11-HY Condition : PEAK_74 3m HORN 9120D-HF HORIZONTAL Project : 7D2018</p>	<p>Site : 03CH11-HY Condition : PEAK_74 3m HORN 9120D-HF VERTICAL Project : 7D2018</p>



WIFI	Band 3 5470~5725MHz Harmonic @ 3m	
ANT	802.11n HT20 CH140 5700MHz	
1	Horizontal	Vertical
Peak Avg.	<p>Site : 03CH11-HY Condition : PEAK_74 3m HORN 9120D-HF HORIZONTAL Project : 7D2018</p>	<p>Site : 03CH11-HY Condition : PEAK_74 3m HORN 9120D-HF VERTICAL Project : 7D2018</p>



Band 3 5470~5725MHz
WIFI 802.11n HT40 (Harmonic @ 3m)

Table with 2 columns: Horizontal and Vertical. Each column contains a graph of Level (dBu/m) vs Frequency (MHz) with peak and average values indicated. Includes site and condition details.

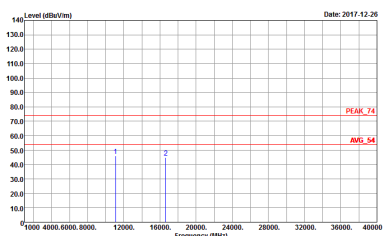
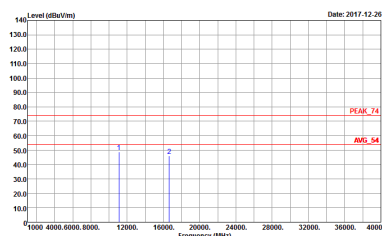

WIFI	Band 3 5470~5725MHz Harmonic @ 3m	
ANT	802.11n HT40 CH110 5550MHz	
1	Horizontal	Vertical
<p>Peak</p> <p>Avg.</p>	 <p>Site : 03CH11-HY Condition : PEAK_74 3m HORN 9120D-HF HORIZONTAL Project : 7D2018</p>	 <p>Site : 03CH11-HY Condition : PEAK_74 3m HORN 9120D-HF VERTICAL Project : 7D2018</p>



WIFI	Band 3 5470~5725MHz Harmonic @ 3m	
ANT	802.11n HT40 CH134 5670MHz	
1	Horizontal	Vertical
Peak Avg.	<p>Site : 03CH11-HY Condition : PEAK_74 3m HORN 9120D-HF HORIZONTAL Project : 7D2018</p>	<p>Site : 03CH11-HY Condition : PEAK_74 3m HORN 9120D-HF VERTICAL Project : 7D2018</p>



Emission below 1GHz
5GHz WIFI 802.11n HT40 (LF)

WIFI	5GHz WIFI	
ANT	802.11n HT40 LF	
1	Horizontal	Vertical
QP / Peak	<p>Site : 03CH11-FY Condition : QP 3m BT-LOG 6111D-LF_ETC HORIZONTAL Detector : Peak Project : 7D2018</p>	<p>Site : 03CH11-FY Condition : QP 3m BT-LOG 6111D-LF_ETC VERTICAL Detector : Peak Project : 7D2018</p>

Appendix E. Duty Cycle Plots

Band	Duty Cycle(%)	T(us)	1/T(kHz)	VBW Setting	Duty Factor(dB)
802.11a	86.26	1356	0.737	1kHz	0.64
5GHz 802.11n HT20	86.18	1272	0.786	1kHz	0.65
5GHz 802.11n HT40	88.80	17.76	56.306	10kHz	0.52

802.11a

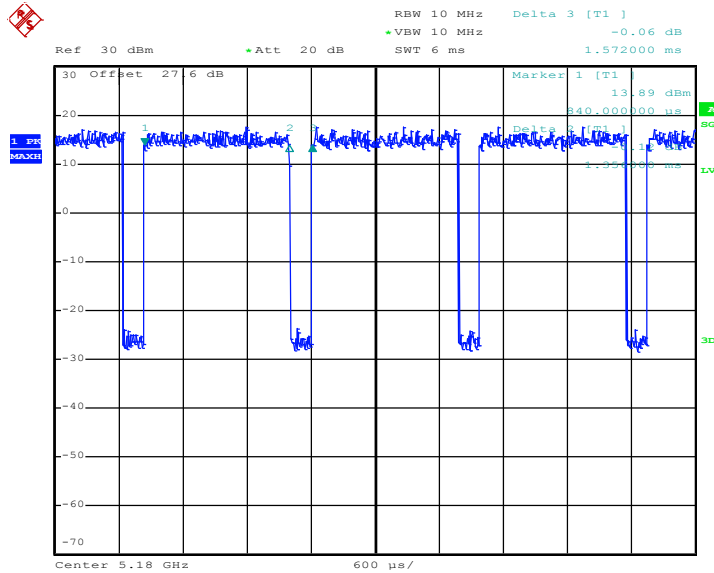

Date: 22.DEC.2017 00:27:25



802.11n HT20

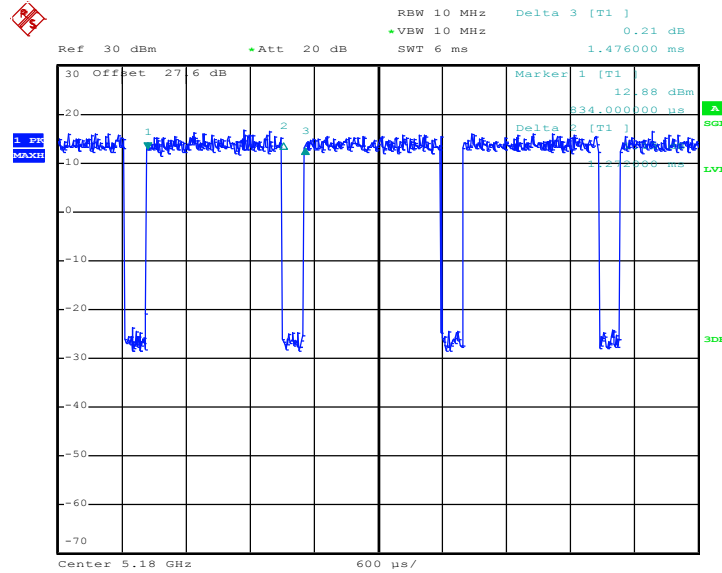

Date: 22.DEC.2017 00:35:52

802.11n HT40

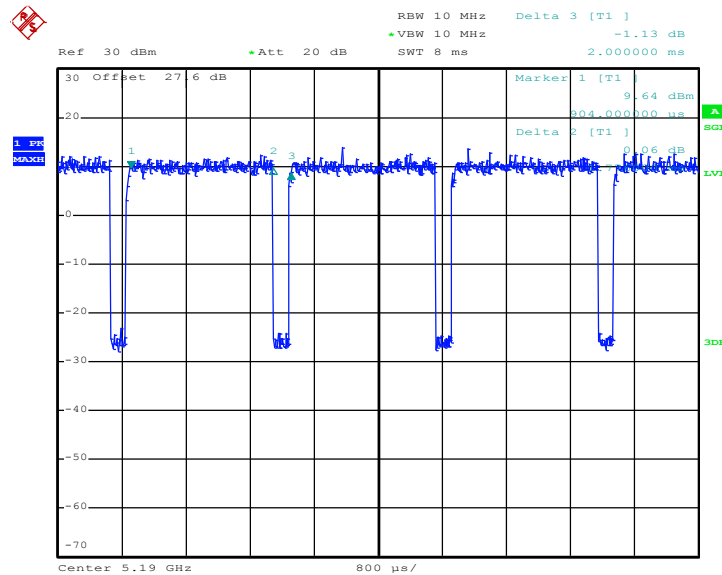

Date: 22.DEC.2017 00:50:07