

Hearing Aid Compatibility (HAC) T-Coil Test Report

APPLICANT : Motorola Mobility LLC
EQUIPMENT : Mobile Cellular Phone
BRAND NAME : Motorola
MODEL NAME : XT1924-7
FCC ID : IHDT56XA2
T-RATING : T3
STANDARD : FCC 47 CFR §20.19
ANSI C63.19-2011

We, SPORTON INTERNATIONAL INC., would like to declare that the tested sample has been evaluated in accordance with the procedures and shown the compliance with the applicable technical standards.

The test results in this report apply exclusively to the tested model / sample. Without written approval of SPORTON INTERNATIONAL INC., the test report shall not be reproduced except in full.

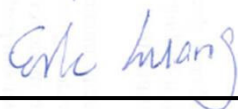

Reviewed by: Eric Huang / Manager



Approved by: Jones Tsai / Manager



SPORTON INTERNATIONAL INC.

No.52, Hwa Ya 1st Rd., Hwa Ya Technology Park, Kwei-Shan District, Taoyuan City, Taiwan
(R.O.C.)



Table of Contents

1. Attestation of Test Summary..... 4

2. General Information..... 5

3. Administration Data..... 6

4. Applied Standards 6

5. Air Interface and Operating Mode..... 7

6. Measurement standards for T-Coil 8

 6.1 Frequency Response 8

 6.2 T-Coil Signal Quality Categories..... 8

7. T-Coil Test Procedure 9

 7.1 Test Flow Chart.....10

 7.2 Test Setup Diagram11

 7.3 Description of EUT Test Position13

8. Test Equipment List.....14

9. T-Coil testing for CMRS Voice.....15

 9.1 GSM Tests Results15

 9.2 UMTS Tests Results16

 9.3 VoLTE Tests Results.....16

 9.4 VoWiFi Tests Results.....18

10. T-Coil testing for OTT VoIP Calling19

11. Uncertainty Assessment20

12. References.....21

Appendix A. Plots of T-Coil Measurement
Appendix B. DASYS Calibration Certificate



Revision History

REPORT NO.	VERSION	DESCRIPTION	ISSUED DATE
HA7D2916B	Rev. 01	Initial issue of report	Mar. 08, 2018



1. Attestation of Test Summary

Air Interface	Band MHz	T-Rating	Frequency Response	Magnetic Intensity
GSM CMRS Voice	GSM850	T3	Pass	Pass
	GSM1900	T3	Pass	Pass
OTT over EDGE	EDGE850	T4	Pass	Pass
	EDGE1900	T4	Pass	Pass
UMTS CMRS Voice	Band 2	T4	Pass	Pass
	Band 4	T4	Pass	Pass
	Band 5	T4	Pass	Pass
OTT over UMTS	Band 2	T4	Pass	Pass
	Band 4	T4	Pass	Pass
	Band 5	T4	Pass	Pass
VoLTE	Band 2	T3	Pass	Pass
	Band 4	T3	Pass	Pass
	Band 5	T3	Pass	Pass
	Band 7	T3	Pass	Pass
	Band 12	T3	Pass	Pass
	Band 13	T3	Pass	Pass
	Band 38	T3	Pass	Pass
	Band 41	T3	Pass	Pass
	Band 66	T3	Pass	Pass
OTT over LTE	Band 2	T4	Pass	Pass
	Band 41	T4	Pass	Pass
VoWiFi	2450	T3	Pass	Pass
	5200	T3	Pass	Pass
	5300	T3	Pass	Pass
	5500	T3	Pass	Pass
	5800	T3	Pass	Pass
OTT over WiFi	2450	T4	Pass	Pass
	5800	T4	Pass	Pass
Date Tested	2018/2/18			

The device is compliance with HAC limits specified in guidelines FCC 47CFR §20.19 and ANSI Standard ANSI C63.19.



2. General Information

Product Feature & Specification	
Applicant Name	Motorola Mobility LLC
Equipment Name	Mobile Cellular Phone
Brand Name	Motorola
Model Name	XT1924-7
FCC ID	IHDT56XA2
HW Version	DVT 1B
SW Version	hannah_t-userdebug 8.0.0 OCP27.35 641 intcfg,test-keys
EUT Stage	Identical Prototype
Exposure category	General Population/Uncontrolled Exposure
Frequency Band	GSM850: 824.2 MHz ~ 848.8 MHz GSM1900: 1850.2 MHz ~ 1909.8 MHz WCDMA Band II: 1852.4 MHz ~ 1907.6 MHz WCDMA Band IV: 1712.4 MHz ~ 1752.6 MHz WCDMA Band V: 826.4 MHz ~ 846.6 MHz LTE Band 2: 1850.7 MHz ~ 1909.3 MHz LTE Band 4: 1710.7 MHz ~ 1754.3 MHz LTE Band 5: 824.7 MHz ~ 848.3 MHz LTE Band 7: 2502.5 MHz ~ 2567.5 MHz LTE Band 12: 699.7 MHz ~ 715.3 MHz LTE Band 13: 779.5 MHz ~ 784.5 MHz LTE Band 38: 2572.5 MHz ~ 2617.5 MHz LTE Band 41: 2498.5 MHz ~ 2687.5 MHz LTE Band 66: 1710.7 MHz ~ 1779.3 MHz LTE Band 71: 665.5 MHz ~ 695.5 MHz WLAN 2.4GHz Band: 2412 MHz ~ 2462 MHz WLAN 5.2GHz Band: 5180 MHz ~ 5240 MHz WLAN 5.3GHz Band: 5260 MHz ~ 5320 MHz WLAN 5.5GHz Band: 5500 MHz ~ 5700 MHz WLAN 5.8GHz Band: 5745 MHz ~ 5825 MHz Bluetooth: 2402 MHz ~ 2480 MHz
Mode	GSM/GPRS/EGPRS RMC/AMR 12.2Kbps HSDPA HSUPA DC-HSDPA LTE: QPSK, 16QAM, 64QAM 802.11a/b/g/n HT20/HT40 Bluetooth v4.2 with LE



3. Administration Data

Sporton Lab is accredited to ISO 17025 by Taiwan Accreditation Foundation (TAF code: 1190) and the FCC designation No. TW1190 under the FCC 2.948(e) by Mutual Recognition Agreement (MRA) in FCC test.

Testing Laboratory	
Test Site	SPORTON INTERNATIONAL INC.
Test Site Location	No.52, Hwa Ya 1st Rd., Hwa Ya Technology Park, Kwei-Shan District, Taoyuan City, Taiwan (R.O.C.) TEL: +886-3-327-3456 FAX: +886-3-328-4978
Test Site No.	Sporton Site No. : SAR04-HY
Applicant	
Company Name	Motorola Mobility LLC
Address	222 W,Merchandise Mart Plaza, Chicago IL 60654 USA
Manufacturer	
Company Name	Motorola Mobility LLC
Address	222 W,Merchandise Mart Plaza, Chicago IL 60654 USA

4. Applied Standards

- FCC CFR47 Part 20.19
- ANSI C63.19-2011
- FCC KDB 285076 D01 HAC Guidance v05
- FCC KDB 285076 D02 T Coil testing v03



5. Air Interface and Operating Mode

Air Interface	Band MHz	Type	C63.19 Tested	Simultaneous Transmitter	Name of Voice Service	Power Reduction
GSM	GSM850	VO	Yes	WLAN, BT	CMRS Voice	No
	GSM1900			WLAN, BT		No
	EDGE850	VD	Yes	WLAN, BT	Google Duo ⁽¹⁾	No
	EDGE1900					
UMTS	850	VO	Yes	WLAN, BT	CMRS Voice	No
	1750			WLAN, BT		No
	1900			WLAN, BT		No
	HSPA	VD	Yes	WLAN, BT	Google Duo ⁽¹⁾	No
LTE (FDD)	Band 2	VD	Yes	WLAN, BT	VoLTE / Google Duo(1)	No
	Band 4			WLAN, BT		No
	Band 5			WLAN, BT		No
	Band 7			WLAN, BT		No
	Band 12			WLAN, BT		No
	Band 13			WLAN, BT		No
	Band 66			WLAN, BT		No
	Band 71			WLAN, BT		No
LTE (TDD)	Band 38	VD	Yes	WLAN, BT	VoLTE / Google Duo(1)	No
	Band 41			WLAN, BT		No
Wi-Fi	2450	VD	Yes	GSM,WCDMA,LTE	VoWiFi / Google Duo(1)	No
	5200			GSM,WCDMA,LTE		No
	5300			GSM,WCDMA,LTE		No
	5500			GSM,WCDMA,LTE		No
	5800			GSM,WCDMA,LTE		No
BT	2450	DT	No	GSM,WCDMA,LTE	NA	No
Type Transport: VO= Voice only DT= Digital Transport only (no voice) VD= CMRS and IP Voice Service over Digital Transport						
Remark: 1. For protocols not listed in Table 7.1 of ANSI C63.19-2011 or the ANSI C63.19-2011 VoLTE interpretation, the average speech level of -20 dBm0 should be used.						

6. Measurement standards for T-Coil

6.1 Frequency Response

The frequency response of the perpendicular component of the magnetic field, measured in 1/3 octave bands, shall follow the response curve specified in this sub-clause, over the frequency range 300 Hz to 3000 Hz.

Figure 1.1 and Figure 1.2 provide the boundaries as a function of frequency. These response curves are for true field-strength measurements of the T-Coil signal. Thus, the 6 dB/octave probe response has been corrected from the raw readings.

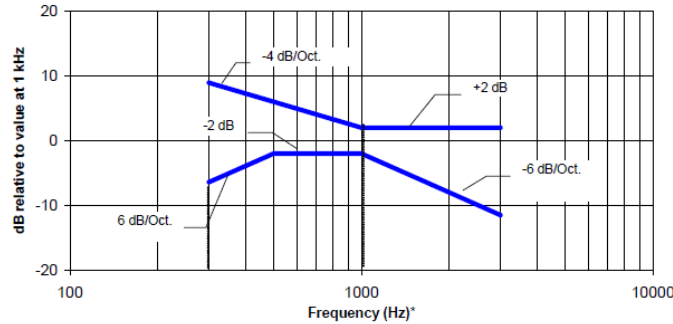

NOTE—The frequency response is between 300 Hz and 3000 Hz.

Fig. 1.1 Magnetic field frequency response for WDs with field strength ≤ -15 dB at 1 kHz

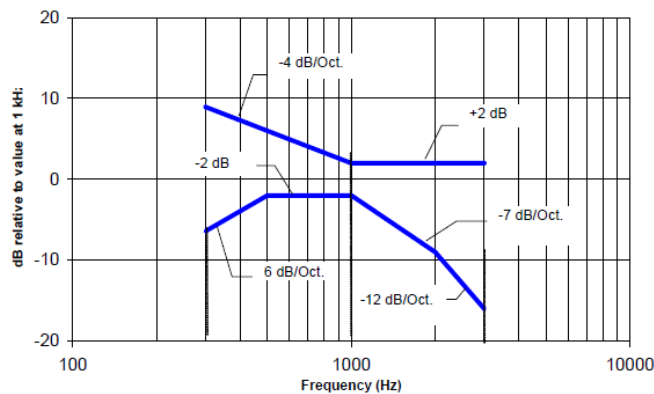

NOTE—The frequency response is between 300 Hz and 3000 Hz.

Fig. 1.2 Magnetic field frequency response for WDs with a field that exceeds -15 dB(A/m) at 1 kHz

6.2 T-Coil Signal Quality Categories

This section provides the signal quality requirement for the intended T-Coil signal from a WD. Only the RF immunity of the hearing aid is measured in T-Coil mode. It is assumed that a hearing aid can have no immunity to an interference signal in the audio band, which is the intended reception band for this mode. A device is assessed beginning by determining the category of the RF environment in the area of the T-Coil source.

The RF measurements made for the T-Coil evaluation are used to assign the category T1 through T4. The limitation is given in Table 1. This establishes the RF environment presented by the WD to a hearing aid.

Category	Telephone parameters WD signal quality ((signal + noise) to noise ratio in dB)
Category T1	0 to 10 dB
Category T2	10 to 20 dB
Category T3	20 to 30 dB
Category T4	> 30 dB

Table 1 T-Coil Signal Quality Categories



7. T-Coil Test Procedure

Referenced to ANSI C63.19-2011, Section 7.4,

This section describes the procedures used to measure the ABM (T-Coil) performance of the WD. In addition to measuring the absolute signal levels, the A-weighted magnitude of the unintended signal shall also be determined. To assure that the required signal quality is measured, the measurement of the intended signal and the measurement of the unintended signal must be made at the same location for each measurement position. In addition, the RF field strength at each measurement location must be at or below that required for the assigned category.

Measurements shall not include undesired properties from the WD's RF field; therefore, use of a coaxial connection to a base station simulator or non-radiating load, there might still be RF leakage from the WD, which can interfere with the desired measurement. Pre-measurement checks should be made to avoid this possibility. All measurements shall be performed with the WD operating on battery power with an appropriate normal speech audio signal input level given in ANSI C63.19-2011 Table 7.1. If the device display can be turned off during a phone call, then that may be done during the measurement as well,

Measurement shall be performed at two locations specified in ANSI C63.19-2011 A.3, with the correct probe orientation for a particular location, in a multistage sequence by first measuring the field intensity of the desired T-Coil signal the same location as the desired ABM or T-Coil signal (ABM1), and the ratio of desired to undesired magnetic components (ABM2) must be measured at the same location as the desired ABM or T-Coil signal (ABM1), and the ratio of desired to undesired ABM signals must be calculated. For the perpendicular field location, only the ABM1 frequency response shall be determined in a third measurement stage.

The following steps summarize the basic test flow for determining ABM1 and ABM2. These steps assume that a sine wave or narrowband 1/3 octave signal can be used for the measurement of ABM1.

- a. A validation of the test setup and instrumentation may be performed using a TMFS or Helmholtz coil Measure the emissions and confirm that they are within the specified tolerance.
- b. Position the WD in the test setup and connect the WD RF connector to a base station simulator or a non-radiating load. Confirm that equipment that requires calibration has been calibrated, and that the noise level meets the requirements given in ANSI C63.19-2011 clause 7.3.1.
- c. The drive level to the WD is set such that the reference input level specified in ANSI C63.19-2011 Table 7.1 is input to the base station simulator (or manufacturer's test mode equivalent) in 1 kHz, 1/3 octave band. This drive level shall be used for the T-Coil signal test (ABM1) at $f = 1$ kHz. Either a sine wave at 1025 Hz or a voice-like signal, band-limited to the 1 kHz 1/3 octave, as defined in ANSI C63.19-2011 clause 7.4.2, shall be used for the reference audio signal. If interference is found at 1025 Hz an alternative nearby reference audio signal frequency may be used. The same drive level shall be used for the ABM1 frequency response measurements at each 1/3 octave band center frequency. The WD volume control may be set at any level up to maximum, provided that a signal at any frequency at maximum modulation would not result in clipping or signal overload.
- d. Determine the magnetic measurement locations for the WD device (A.3), if not already specified by the manufacturer, as described in ANSI C63.19-2011 clause 7.4.4.1.1 and 7.4.4.2.
- e. At each measurement location, measure and record the desired T-Coil magnetic signals (ABM1 at f_i) as described in ANSI C63.19-2011 clause 7.4.4.2 in each individual ISO 266-1975 R10 standard 1/3 octave band. The desired audio band input frequency (f_i) shall be centered in each 1/3 octave band maintaining the same drive level as determined in item c) and the reading taken for that band.
- f. Equivalent methods of determining the frequency response may also be employed, such as fast Fourier transform (FFT) analysis using noise excitation or input-output comparison using simulated speech. The full-band integrated probe output, as specified in D.9, may be used, as long as the appropriate calibration curve is applied to the measured result, so as to yield an accurate measurement of the field magnitude. (The resulting measurement shall be an accurate measurement in dB A/m.)
- g. All Measurements of the desired signal shall be shown to be of the desired signal and not of an undesired signal. This may be shown by turning the desired signal ON and OFF with the probe measuring the same location. If the scanning method is used the scans shall show that all measurement points selected for the ABM1 measurement meet the ambient and test system noise criteria in ANSI C63.19-2011 clause 7.3.1.
- h. At the measurement location for each orientation, measure and record the undesired broadband audio magnetic signal (ABM2) as specified in ANSI C63.19-2011 clause 7.4.4.4 with no audio signal applied (or digital zero applied, if appropriate) using A-weighting and the half-band integrator. Calculate the ratio of the desired to undesired signal strength (i.e., signal quality).
- i. Obtain the data from the postprocessor, SEMCAD, and determine the category that properly classifies the signal quality based on ANSI C63.19-2011 Table 8.5.

7.1 Test Flow Chart

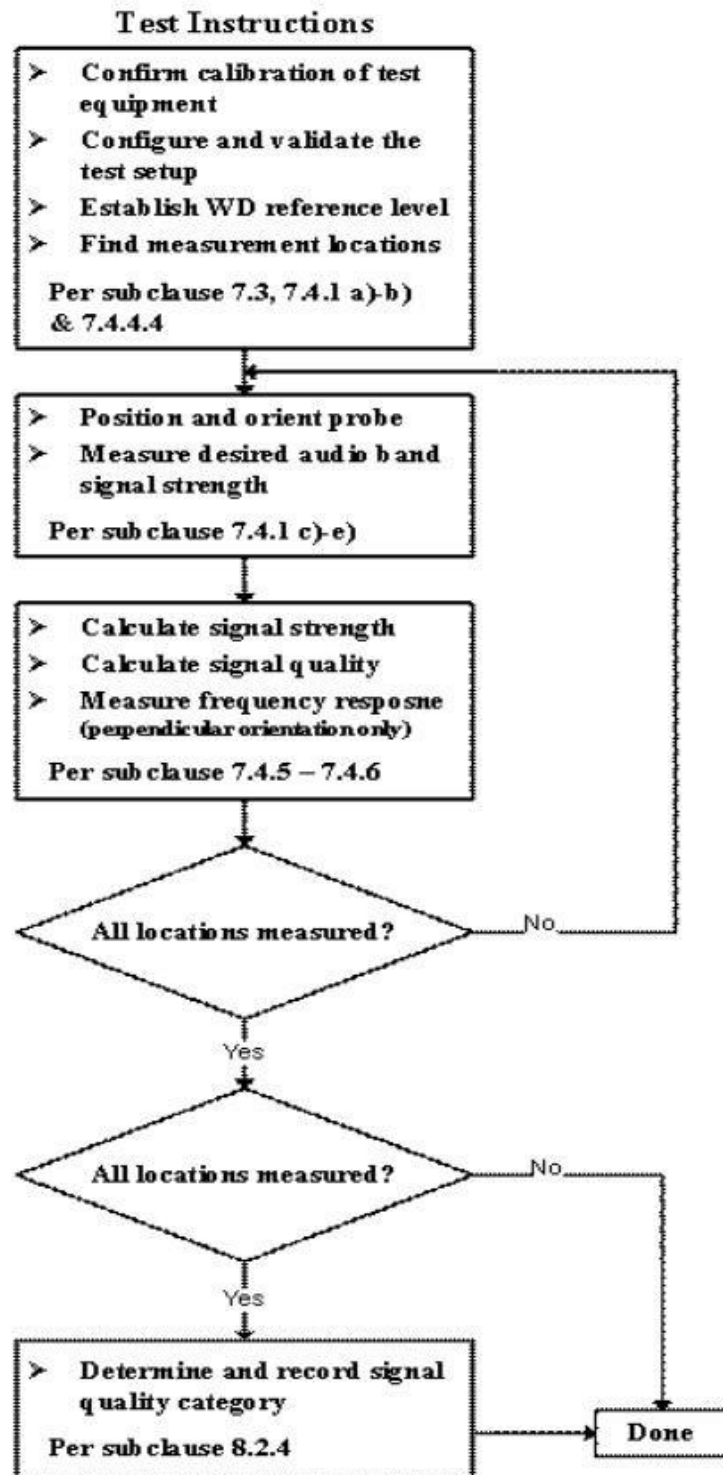
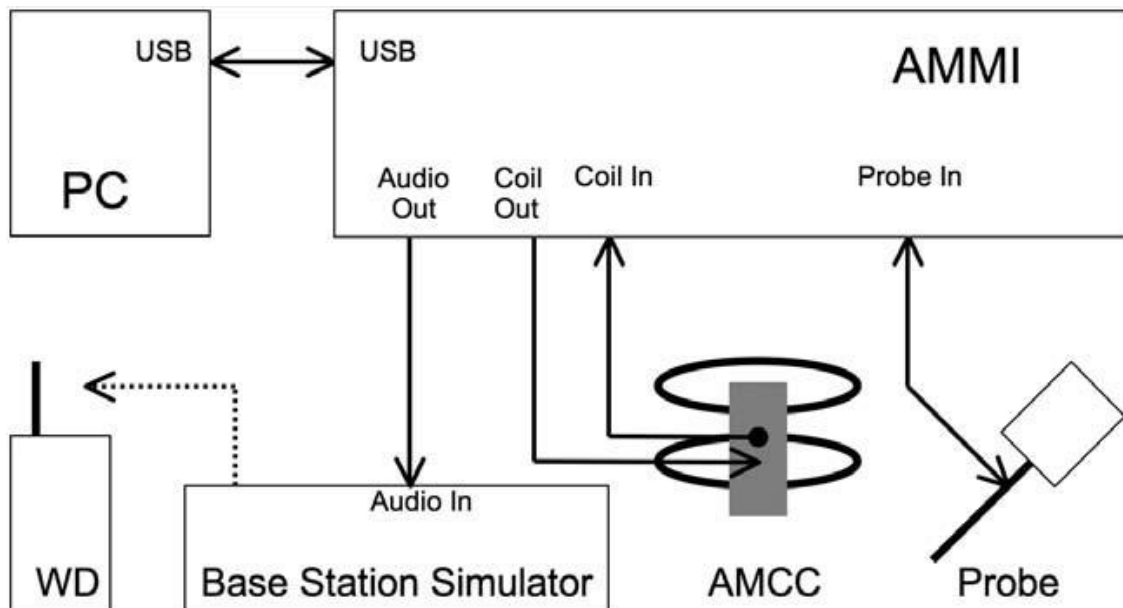

Fig. 2 T-Coil Signal Test flowchart

7.2 Test Setup Diagram



General Note:

1. Define the all applicable input audio level as below according to C63 and KDB 285076 D02v03:
 - GSM input level: -16dBm0
 - UMTS input level: -16dBm0
 - CDMA input level: -18dBm0
 - VoLTE input level: -16dBm0
 - VoWiFi input level: -20dBm0
 - OTT VoIP input Level: -20dBm0
2. For GSM / UMTS / CDMA test setup and input level, the correct input level definition is via a communication tester CMU200's "Decoder Cal" and "Codec Cal" with audio option B52 and B85 to set the correct audio input levels.
3. CMU200 is able to output 1kHz audio signal equivalent to 3.14dBm0 at "Decoder Cal." configuration, the signal reference is used to adjust the AMMI gain setting to reach -16dBm0 for GSM/UMTS and -18dBm0 for CDMA. CMW500 input is calibrated and the relation between the analog input voltage and the internal level in dBm0 can be determined
4. The test setup used for VoLTE over IMS and VoWiFi over IMS is via the callbox of CMW500 for T-coil measurement, The data application unit of the CMW500 was used to simulate the IP multimedia subsystem server. The CMW500 can be manually configured to ensure and control the speech input level result is -16dBm0 for VoLTE, -20dBm0 for VoWiFi when the device during the IMS connection.
5. The test setup used for OTT VoIP call is via the data application unit on CMW500 connection to the Internet, also connection to the other auxiliary VoIP unit which is used to configure the audio codec and bit rate and also monitor the audio input level of -20dBm0.



1. The Required gain factor for the specific signal shall typically be multiplied by this factor to achieve approx. the same level as for the 1kHz sine signal
2. The below calculation formula is an example and showing how to determine the input level for the device.

The predefined signal types have the following differences / factors compared to the 1kHz sine signal:

Signal [file name]	Duration [s]	Peak-to-RMS [dB]	RMS [dB]	Required gain factor *)	Gain setting
1kHz sine	---	3.0	0.0	1.00	
48k_1.025kHz_10s.wav	10	3.0	0.0	1.00	
48k_1kHz_3.15kHz_10s.wav	10	6.0	-3.0	1.42	
48k_315Hz_1kHz_10s.wav	10	6.0	-2.9	1.40	
48k_csek_8k_441_white_10s.wav	10	13.8	-10.5	3.34	
48k_multisine_50-5000_10s.wav	10	11.1	-7.9	2.49	
48k_voice_1kHz_1s.wav	1	16.2	-12.7	4.33	
48k_voice_300-3000_2s.wav	2	21.6	-18.6	8.48	

(*) The gain for the specific signal shall typically be multiplied by this factor to achieve approx. the same level as for the 1kHz sine signal.

Insert the gain applicable for your setup in the last column of the table.

<An example for determine input level>

- Audio Level at -16dBm0 = ((-16dBm0) – (3.14dBm0)) + X dBv
- Calculated Gain at -16dBm0 = 10((audio level at -16dBm0 – Y dBm0) / 20) * 10
- Gating setting at -16dBm0 = required gain factor * calculated gain

Gain Value (linear)	20* log(gain) dB	AMCC Coil In (dBv RMS)	Level dBm0
		-2.39	3.14
10	20	-19.93	-14.40
8.32	18.40	-21.53	-16

Signal Type	Duration (s)	Peak to RMS (dB)	RMS (dB)	Required Gain Factor	Calculated Gain Setting
1kHz sine	-	3	0	1	8.32
48k_voice_1kHz	1	16.2	-12.7	4.33	36.02
48k_voice_300Hz ~ 3kHz	2	21.6	-18.6	8.48	70.53

7.3 Description of EUT Test Position

Fig.3 illustrate the references and reference plane that shall be used in a typical EUT emissions measurement. The principle of this section is applied to EUT with similar geometry. Please refer to Appendix C for the setup photographs.

- ◆ The area is 5 cm by 5 cm.
- ◆ The area is centered on the audio frequency output transducer of the EUT.
- ◆ The area is in a reference plane, which is defined as the planar area that contains the highest point in the area of the phone that normally rests against the user’s ear. It is parallel to the centerline of the receiver area of the phone and is defined by the points of the receiver-end of the EUT handset, which, in normal handset use, rest against the ear.
- ◆ The measurement plane is parallel to, and 10 mm in front of, the reference plane.

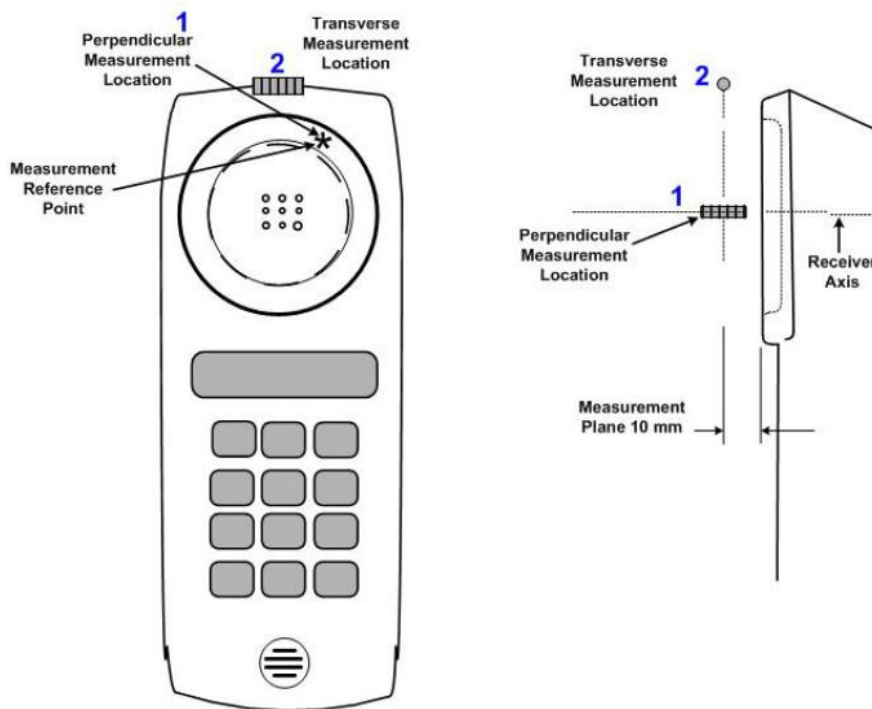

Fig.3 A typical EUT reference and plane for T-Coil measurements



8. Test Equipment List

Manufacturer	Name of Equipment	Type/Model	Serial Number	Calibration	
				Last Cal.	Due Date
SPEAG	Audio Magnetic 1D Field Probe	AM1DV3	3130	Nov. 21, 2017	Nov. 20, 2018
SPEAG	Data Acquisition Electronics	DAE4	854	May. 02, 2017	May. 01, 2018
SPEAG	Audio Magnetic Calibration Coil	AMCC	1049	NCR	NCR
SPEAG	Audio Measuring Instrument	AMMI	1041	NCR	NCR
SPEAG	Test Arch Phantom	N/A	N/A	NCR	NCR
SPEAG	Phone Positioner	N/A	N/A	NCR	NCR
Gencom	Thermometer	TE1	TM685-1	Mar. 21, 2017	Mar. 20, 2018
Gencom	Thermometer	TE1	TM685-2	Mar. 21, 2017	Mar. 20, 2018
R&S	Base Station	CMW500	115793	Aug. 23, 2017	Aug. 22, 2019
R&S	Base Station	CMW500	116160	Mar. 08, 2017	Mar. 07, 2018
R&S	Base Station	CMU200	116457	May. 23, 2017	May. 22, 2018

Note:

- 1. NCR: "No-Calibration Required"

9. T-Coil testing for CMRS Voice

General Note:

1. The middle channel of each frequency band is used for T-Coil testing according ANSI C63.19 2011.
2. For VoLTE or VoWiFi radio configuration investigation is choose either one codec and an investigation was performed on all frequency band, data rates and modulations and RB configuration to determine the radio configuration to be used for testing, the following tests results which the worst case configuration would be remarked to be used for the testing for the handset.
3. Choose worst case from radio configuration investigation. After investigation was performed to determine the audio codec configuration to be used for testing, the following tests results which the worst case codec would be remarked to be used for the testing for the handset.
4. According to 3GPP 36.211 Table 4.2-2, the TDD LTE power class 3 supports uplink-downlink configuration 0 to 6, an investigation was performed to determine the worst-case uplink-downlink configuration and with the FDD LTE worst case radio configuration.
5. For VoWiFi codec selection, due to the same with VoLTE codec configuration, therefore, worst codec is choose from VoLTE codec investigation to be used for others air interfaces testing of VoWiFi.

9.1 GSM Tests Results

<Codec Investigation>

Codec	FR V1	HR V1	Orientation	Band / Channel
ABM 1 (dBA/m)	-6.45	-5.39	Axial	GSM850 / 189
ABM 2 (dBA/m)	-30.64	-31.41		
Signal Quality (dB)	24.19	26.02		
Freq. Response	PASS	PASS		

<Summary Tests Results>

Plot No.	Air Interface	Mode	Channel	Probe Position	ABM1 dB (A/m)	ABM2 dB (A/m)	Signal Quality dB	T Rating	Frequency Response
1	GSM850	CMRS Voice	189	Axial (Z)	-6.45	-30.64	24.19	T3	PASS
				Transversal (Y)	-15.45	-40.37	24.92	T3	
2	GSM1900	CMRS Voice	661	Axial (Z)	-5.72	-32.83	27.11	T3	PASS
				Transversal (Y)	-13.57	-41.20	27.63	T3	



9.2 UMTS Tests Results

<Codec Investigation>

Codec	AMR 4.75Kbps	AMR 7.95Kbps	AMR 12.2Kbps	Orientation	Band / Channel
ABM 1 (dBA/m)	-8.8	-7.72	-5.83	Axial	Band 2 / 9400
ABM 2 (dBA/m)	-42.00	-40.77	-37.84		
Freq. Response	Pass	Pass	Pass		
Signal Quality (dB)	33.2	33.05	32.01		

<Summary Tests Results>

Plot No.	Air Interface	Mode	Channel	Probe Position	ABM1 dB (A/m)	ABM2 dB (A/m)	Signal Quality dB	T Rating	Frequency Response
3	WCDMA II	AMR 12.2Kbps	9400	Axial (Z)	-5.83	-37.84	32.01	T4	PASS
				Transversal (Y)	-12.74	-43.20	30.46	T4	
4	WCDMA IV	AMR 12.2Kbps	1413	Axial (Z)	-6.58	-38.69	32.11	T4	PASS
				Transversal (Y)	-12.70	-43.36	30.66	T4	
5	WCDMA V	AMR 12.2Kbps	4182	Axial (Z)	-8.57	-40.72	32.15	T4	PASS
				Transversal (Y)	-12.47	-43.14	30.67	T4	

9.3 VoLTE Tests Results

<Radio Configuration Investigation>

Air Interface	bandwidth	modulation	RB size	RB offset	Channel	UL-DL Configuration	ABM1 dB A/m)	ABM2 dB (A/m)	Signal Quality dB
LTE B2	20	QPSK	1	0	18900		-8.38	-38.37	29.99
LTE B2	20	QPSK	50	0	18900		-8.36	-39.91	31.55
LTE B2	20	QPSK	100	0	18900		-8.37	-39.48	31.11
LTE B2	20	16QAM	1	0	18900		-8.34	-39.04	30.70
LTE B2	15	QPSK	1	0	18900		-8.35	-38.57	30.22
LTE B2	10	QPSK	1	0	18900		-9.43	-40.25	30.82
LTE B2	5	QPSK	1	0	18900		-8.33	-38.97	30.64
LTE B2	3	QPSK	1	0	18900		-8.33	-39.07	30.74
LTE B2	1.4	QPSK	1	0	18900		-9.47	-39.59	30.12
LTE B41	20	QPSK	1	0	40620	0	-7.29	-34.36	27.07
LTE B41	20	QPSK	1	0	40620	1	-7.28	-35.24	27.96
LTE B41	20	QPSK	1	0	40620	2	-7.24	-34.43	27.19
LTE B41	20	QPSK	1	0	40620	3	-7.25	-35.26	28.01
LTE B41	20	QPSK	1	0	40620	4	-7.23	-35.44	28.21
LTE B41	20	QPSK	1	0	40620	5	-7.27	-34.67	27.40
LTE B41	20	QPSK	1	0	40620	6	-7.27	-34.57	27.30



<AMR Codec Investigation>

Codec	NB AMR 4.75Kbps	NB AMR 12.2Kbps	WB AMR 6.60Kbps	WB AMR 23.85Kbps	Orientation	Band / BW / Channel
ABM 1 (dBA/m)	-10.31	-9.99	-8.25	-7.5	Axial	B2 / 20M / 18900
ABM 2 (dBA/m)	-40.47	-40.11	-39.58	-37.63		
Freq. Response	Pass	Pass	Pass	Pass		
Signal Quality (dB)	30.16	30.12	31.33	30.13		

<EVS Codec Investigation>

Codec	EVS SWB 9.6Kbps	EVS SWB 13.2Kbps	EVS WB 5.9Kbps	EVS WB 13.2Kbps	EVS NB 5.9Kbps	EVS NB 13.2Kbps	Orientation	Band / BW / Channel
ABM 1 (dBA/m)	-8.28	-8.08	-7.43	-8.09	-7.43	-7.43	Axial	B2 / 20M / 18900
ABM 2 (dBA/m)	-39.9	-39.26	-39.16	-39.89	-38.88	-39.16		
Freq. Response	Pass	Pass	Pass	Pass	Pass	Pass		
Signal Quality (dB)	31.62	31.18	31.73	31.8	31.45	31.73		

<Summary Tests Results>

Plot No.	Air Interface	BW (MHz)	Modulation	RB Size	RB offset	Channel	Probe Position	ABM1 dB (A/m)	ABM2 dB (A/m)	Signal Quality dB	T Rating	Frequency Response
6	LTE Band 2	20	QPSK	1	0	18900	Axial (Z)	-9.99	-40.11	30.12	T4	PASS
							Transversal (Y)	-13.94	-42.10	28.16	T3	
7	LTE Band 4	20	QPSK	1	0	20175	Axial (Z)	-5.31	-36.78	31.47	T4	PASS
							Transversal (Y)	-14.67	-43.39	28.72	T3	
8	LTE Band 5	10	QPSK	1	0	20525	Axial (Z)	-5.04	-36.94	31.90	T4	PASS
							Transversal (Y)	-14.16	-43.18	29.02	T3	
9	LTE Band 7	20	QPSK	1	0	21100	Axial (Z)	-6.21	-37.18	30.97	T4	PASS
							Transversal (Y)	-13.21	-41.99	28.78	T3	
10	LTE Band 12	10	QPSK	1	0	23095	Axial (Z)	-7.89	-39.58	31.69	T4	PASS
							Transversal (Y)	-14.65	-44.04	29.39	T3	
11	LTE Band 13	10	QPSK	1	0	23230	Axial (Z)	-7.84	-40.22	32.38	T4	PASS
							Transversal (Y)	-14.69	-44.01	29.32	T3	
12	LTE Band 66	20	QPSK	1	0	132322	Axial (Z)	-6.65	-38.69	32.04	T4	PASS
							Transversal (Y)	-14.30	-43.37	29.07	T3	
13	LTE Band 71	20	QPSK	1	0	133322	Axial (Z)	-8.04	-39.57	31.53	T4	PASS
							Transversal (Y)	-14.66	-42.92	28.26	T3	
14	LTE Band 38	20	QPSK	1	0	38000	Axial (Z)	-7.23	-33.98	26.75	T3	PASS
							Transversal (Y)	-15.36	-40.66	25.30	T3	
15	LTE Band 41	20	QPSK	1	0	40620	Axial (Z)	-7.99	-35.19	27.20	T3	PASS
							Transversal (Y)	-15.12	-40.40	25.28	T3	



9.4 VoWiFi Tests Results

<Radio Configuration Investigation>

Air Interface	Bandwidth	Data rate	channel	ABM1 dB (A/m)	ABM2 dB (A/m)	Signal Quality (dB)
802.11b	20	1M	6	-10.38	-40.41	30.03
802.11b	20	11M	6	-10.03	-40.49	30.46
802.11g	20	6M	6	-10.10	-40.35	30.25
802.11g	20	54M	6	-10.38	-40.44	30.06
802.11n-HT20	20	MCS0	6	-10.09	-40.47	30.38
802.11n-HT20	20	MCS7	6	-10.10	-40.26	30.16
802.11a	20	6M	40	-10.56	-39.56	29.00
802.11a	20	54M	40	-10.58	-40.67	30.09
802.11an-HT20	20	MCS0	40	-10.58	-40.81	30.23
802.11an-HT20	20	MCS7	40	-10.58	-39.62	29.04
802.11an-HT40	40	MCS0	38	-10.57	-39.73	29.16
802.11an-HT40	40	MCS7	38	-10.57	-41.06	30.49

<Summary Tests Results>

Plot No.	Air Interface	Mode	Channel	Probe Position	ABM1 dB (A/m)	ABM2 dB (A/m)	Signal Quality dB	T Rating	Frequency Response
16	WLAN2.4GHz	802.11b 1Mbps	6	Axial (Z)	-10.54	-40.50	29.96	T3	Pass
				Transversal (Y)	-16.14	-41.22	25.08	T3	
17	WLAN5GHz	802.11a 6Mbps	40	Axial (Z)	-10.71	-40.76	30.05	T4	Pass
				Transversal (Y)	-15.87	-40.07	24.20	T3	
18	WLAN5GHz	802.11a 6Mbps	60	Axial (Z)	-9.68	-39.68	30.00	T3	Pass
				Transversal (Y)	-16.55	-42.79	26.24	T3	
19	WLAN5GHz	802.11a 6Mbps	124	Axial (Z)	-9.74	-39.75	30.01	T4	Pass
				Transversal (Y)	-15.55	-41.71	26.16	T3	
20	WLAN5GHz	802.11a 6Mbps	157	Axial (Z)	-9.84	-38.61	28.77	T3	Pass
				Transversal (Y)	-15.26	-40.26	25.00	T3	

10. T-Coil testing for OTT VoIP Calling

General Notes:

1. The google Duo VoIP call software is pre-installed on this device and head-to-ear scenario should be consideration, the google Duo only support OPUS audio codec and support 6Kbpa to 75Kbps bitrate. According to KDB 285076 D02, all air interfaces via a data connection with google Duo VoIP calling would be consideration to be tested.
2. The test setup used for OTT VoIP call is via the data application unit on CMW500 connection to the Internet, also connection to the other auxiliary VoIP unit which is used to configure the audio codec and bit rate and also monitor the audio input level of -20dBm0
3. According to VoLTE and VoWiFi radio configuration investigation, the worst case radio configuration is used for OTT over LTE and OTT over WiFi testing.
4. Due to OTT service and CMRS IP service are all be established over the internet protocol for the voice service, and on both services use the identical RF air interface for the WIFI and LTE, therefore according to VOLTE and VoWifi summary test results, the worst case air interface is used for OTT T-Coil testing.
5. For OTT VoIP codec investigation test reduction, due to all air interface have the same codec configuration, therefore, the codec investigation was choose UMTS B2 to determine the audio codec configuration to be used for others air interfaces testing.

<Codec Investigation>

Codec	Bitrate 6Kbps	Bitrate 40Kbps	Bitrate 70Kbps	Orientation	Band / Channel
ABM 1 (dBA/m)	11.97	11.74	9.1	Axial	UMTS B2 / 9400
ABM 2 (dBA/m)	-37.17	-37.94	-40.66		
Freq. Response	Pass	Pass	Pass		
Signal Quality (dB)	49.14	49.68	49.76		

<Summary Tests Results>

Plot No.	Air Interface	Mode	Channel	Probe Position	ABM1 dB (A/m)	ABM2 dB (A/m)	Signal Quality dB	T Rating	Frequency Response
21	GSM850	EDGE	189	Axial (Z)	11.13	-36.23	47.36	T4	Pass
				Transversal (Y)	1.77	-44.23	46.00	T4	
22	GSM1900	EDGE	661	Axial (Z)	11.11	-36.60	47.71	T4	Pass
				Transversal (Y)	1.73	-44.87	46.60	T4	
23	WCDMA II	HSPA	9400	Axial (Z)	11.97	-37.17	49.14	T4	Pass
				Transversal (Y)	1.86	-45.78	47.64	T4	
24	WCDMA IV	HSPA	1413	Axial (Z)	10.06	-39.32	49.38	T4	Pass
				Transversal (Y)	1.83	-45.80	47.63	T4	
25	WCDMA V	HSPA	4182	Axial (Z)	10.29	-39.33	49.62	T4	Pass
				Transversal (Y)	2.03	-45.26	47.29	T4	
26	LTE Band 2	QPSK	18900	Axial (Z)	12.41	-37.97	50.38	T4	Pass
				Transversal (Y)	2.91	-44.12	47.03	T4	
27	LTE Band 41	QPSK	40620	Axial (Z)	7.41	-38.78	46.19	T4	Pass
				Transversal (Y)	1.01	-39.38	40.39	T4	
28	WLAN2.4GHz	802.11b 1Mbps	6	Axial (Z)	11.74	-36.48	48.22	T4	Pass
				Transversal (Y)	1.93	-39.04	40.97	T4	
29	WLAN5GHz	802.11a 6Mbps	40	Axial (Z)	11.44	-37.15	48.59	T4	Pass
				Transversal (Y)	1.59	-39.88	41.47	T4	

Remark:

1. Phone Condition: Mute on; Backlight off; Max Volume
2. The detail frequency response results please refer to appendix A.
3. Test Engineer : Nick Yu and Steven Chang



11. Uncertainty Assessment

The evaluation of uncertainty by the statistical analysis of a series of observations is termed a Type A evaluation of uncertainty. The evaluation of uncertainty by means other than the statistical analysis of a series of observation is termed a Type B evaluation of uncertainty. Each component of uncertainty, however evaluated, is represented by an estimated standard deviation, termed standard uncertainty, which is determined by the positive square root of the estimated variance. The combined standard uncertainty of the measurement result represents the estimated standard deviation of the result. It is obtained by combining the individual standard uncertainties of both Type A and Type B evaluation using the usual “root-sum-squares” (RSS) methods of combining standard deviations by taking the positive square root of the estimated variances. Expanded uncertainty is a measure of uncertainty that defines an interval about the measurement result within which the measured value is confidently believed to lie. It is obtained by multiplying the combined standard uncertainty by a coverage factor. For purpose of this document, a coverage factor two is used, which corresponds to confidence interval of about 95 %. The DASy uncertainty Budget is showed in Table 8.2.

Error Description	Uncertainty Value (±%)	Probability Distribution	Divisor	Ci (ABM1)	Ci (ABM2)	Standard Uncertainty (ABM1)	Standard Uncertainty (ABM2)
Probe Sensitivity							
Reference Level	3.0	Normal	1	1	1	± 3.0 %	± 3.0 %
AMCC Geometry	0.4	Rectangular	√3	1	1	± 0.2 %	± 0.2 %
AMCC Current	1.0	Rectangular	√3	1	1	± 0.6 %	± 0.6 %
Probe Positioning During Calibrate	0.1	Rectangular	√3	1	1	± 0.1 %	± 0.1 %
Noise Contribution	0.7	Rectangular	√3	0.0143	1	± 0.0 %	± 0.4 %
Frequency Slope	5.9	Rectangular	√3	0.1	1	± 0.3 %	± 3.5 %
Probe System							
Repeatability / Drift	1.0	Rectangular	√3	1	1	± 0.6 %	± 0.6 %
Linearity / Dynamic Range	0.6	Rectangular	√3	1	1	± 0.4 %	± 0.4 %
Acoustic Noise	1.0	Rectangular	√3	0.1	1	± 0.1 %	± 0.6 %
Probe Angle	2.3	Rectangular	√3	1	1	± 1.4 %	± 1.4 %
Spectral Processing	0.9	Rectangular	√3	1	1	± 0.5 %	± 0.5 %
Integration Time	0.6	Normal	1	1	5	± 0.6 %	± 3.0 %
Field Disturbation	0.2	Rectangular	√3	1	1	± 0.1 %	± 0.1 %
Test Signal							
Reference Signal Spectral Response	0.6	Rectangular	√3	0	1	± 0.0 %	± 0.4 %
Positioning							
Probe Positioning	1.9	Rectangular	√3	1	1	± 1.1 %	± 1.1 %
Phantom Thickness	0.9	Rectangular	√3	1	1	± 0.5 %	± 0.5 %
EUT Positioning	1.9	Rectangular	√3	1	1	± 1.1 %	± 1.1 %
External Contributions							
RF Interference	0.0	Rectangular	√3	1	0.3	± 0.0 %	± 0.0 %
Test Signal Variation	2.0	Rectangular	√3	1	1	± 1.2 %	± 1.2 %
Combined Standard Uncertainty						± 4.1 %	± 6.1 %
Coverage Factor for 95 %						K = 2	
Expanded Uncertainty						± 8.1 %	± 12.3 %

Table 8.2 Uncertainty Budget of audio band magnetic measurement



12. References

- [1] ANSI C63.19-2011, "American National Standard for Methods of Measurement of Compatibility between Wireless Communications Devices and Hearing Aids", 27 May 2011.
- [2] FCC KDB 285076 D01v05, "Equipment Authorization Guidance for Hearing Aid Compatibility", Sep 2017
- [3] FCC KDB 285076 D02v03, "Guidance for performing T-Coil tests for air interfaces supporting voice over IP (e.g., LTE and WiFi) to support CMRS based telephone services", Sep 2017
- [4] SPEAG DASY System Handbook