



FCC RF Test Report

APPLICANT : Motorola Mobility LLC
EQUIPMENT : Mobile Cellular Phone
BRAND NAME : Motorola
MODEL NAME : XT1926-5
FCC ID : IHDT56WL3
STANDARD : FCC Part 15 Subpart E §15.407
CLASSIFICATION : (NII) Unlicensed National Information Infrastructure

The product was received on Dec. 28, 2017 and testing was completed on Feb. 13, 2018. We, SPORTON INTERNATIONAL INC., would like to declare that the tested sample has been evaluated in accordance with the test procedures and has been in compliance with the applicable technical standards.

The test results in this report apply exclusively to the tested model / sample. Without written approval of SPORTON INTERNATIONAL INC., the test report shall not be reproduced except in full.

Reviewed by: Joseph Lin / Supervisor

Approved by: Jones Tsai / Manager



SPORTON INTERNATIONAL INC.

No. 52, Hwa Ya 1st Rd., Hwa Ya Technology Park, Kwei-Shan District, Tao Yuan City, Taiwan, R.O.C.



TABLE OF CONTENTS

1 GENERAL DESCRIPTION 5

1.1 Applicant 5

1.2 Manufacturer 5

1.3 Product Feature of Equipment Under Test 5

1.4 Product Specification of Equipment Under Test 5

1.5 Re-use of Measured Data 6

1.6 Specification of Accessory 7

1.7 Modification of EUT 8

1.8 Testing Location 8

1.9 Applicable Standards 8

2 TEST CONFIGURATION OF EQUIPMENT UNDER TEST 9

2.1 Carrier Frequency and Channel 9

2.2 Test Mode 10

2.3 Connection Diagram of Test System 11

2.4 EUT Operation Test Setup 11

3 TEST RESULT 12

3.1 Unwanted Emissions Measurement 12

4 LIST OF MEASURING EQUIPMENT 18

5 UNCERTAINTY OF EVALUATION 19

APPENDIX A. RADIATED SPURIOUS EMISSION

APPENDIX B. DUTY CYCLE PLOTS

APPENDIX C. SETUP PHOTOGRAPHS

APPENDIX D. REFERENCE REPORT



REVISION HISTORY

REPORT NO.	VERSION	DESCRIPTION	ISSUED DATE
FR7D2702-05F	Rev. 01	Initial issue of report	Mar. 12, 2018



SUMMARY OF TEST RESULT

Report Section	FCC Rule	Description	Limit	Result	Remark
3.1	15.407(b)	Unwanted Emissions	15.407(b)(4)(i) &15.209(a)	Pass	Under limit 3.11 dB at 11650.000 MHz



1 General Description

1.1 Applicant

Motorola Mobility LLC
222 W, Merchandise Mart Plaza, Chicago IL 60654 USA

1.2 Manufacturer

Motorola Mobility LLC
222 W, Merchandise Mart Plaza, Chicago IL 60654 USA

1.3 Product Feature of Equipment Under Test

Product Feature	
Equipment	Mobile Cellular Phone
Brand Name	Motorola
Model Name	XT1926-5
FCC ID	IHDT56WL3
EUT supports Radios application	GSM/GPRS/EGPRS/WCDMA/HSPA/DC-HSDPA/ HSPA+(16QAM uplink is not supported)/LTE/NFC WLAN 2.4GHz 802.11b/g/n HT20 WLAN 5GHz 802.11a/n HT20/HT40 WLAN 5GHz 802.11ac VHT20/VHT40/VHT80 Bluetooth v3.0+EDR/ Bluetooth v4.0 LE/ Bluetooth v4.1 LE/ Bluetooth v4.2 LE/ Bluetooth v5.0 LE
IMEI Code	Radiation: 351855090018252/ 351855090018260
HW Version	DVT1B
SW Version	evert_n-userdebug 8.0.0 OPW27.88 1825 intcfg,test-keys
EUT Stage	Identical Prototype

Remark: The above EUT's information was declared by manufacturer. Please refer to the specifications or user's manual for more detailed description.

1.4 Product Specification of Equipment Under Test

Standards-related Product Specification	
Tx/Rx Channel Frequency Range	5745 MHz ~ 5825 MHz
Type of Modulation	802.11a/n : OFDM (BPSK / QPSK / 16QAM / 64QAM) 802.11ac : OFDM (BPSK / QPSK / 16QAM / 64QAM / 256QAM)
Antenna Type / Gain	PIFA Antenna with gain -3.0 dBi



1.5 Re-use of Measured Data

1.5.1 Introduction Section

This application re-uses data collected on a similar device. The subject device of this application (Model: XT1926-5, FCC ID: IHDT56WL3) is electrically identical to the reference device (Model: XT1926-6, XT1926-7, FCC ID: IHDT56WL4) for the portions of the circuitry corresponding to the data being re-used, as treated by KDB Publication 178919 D01.

1.5.2 Difference Section

For details concerning the similarity with respect to component placement, mechanical/electrical design etc., please refer to the Product Equality Declaration.

The re-used RF data includes the following bands provided in Appendix D (Sporton RF Report No. FR7D2702F for the reference device Model: XT1926-6, XT1926-7, FCC ID: IHDT56WL4):

1.5.3 Spot Check Verification Data Section

In order to confirm hardware similarity of the subject device with the reference device, spot check measurements were performed on the subject device for conducted power, the test result were consistent with FCC ID: IHDT56WL4.

Assertions concerning the similarity of these devices are based on representations by the applicant. The applicant accepts full responsibility for the validity of the similarity claim, and for the determination that verification test data are sufficient to support it.

1.5.4 Reference detail Section:

Equipment Class	Reference FCC ID	Folder Test	Report Title/Section
U-NII (B1~3)	IHDT56WL4	Part15E(FR7D2702E)	All sections (except RSE) applicable
U-NII (B4)	IHDT56WL4	Part15E(FR7D2702F)	All sections (except RSE) applicable
U-NII (DFS)	IHDT56WL4	Part15E(FZ7D2702)	All sections applicable



1.6 Specification of Accessory

Specification of Accessory			
AC Adapter 1(US)	Brand Name	Motorola (Salom)	Model Name SC-22
	Power Rating	I/P: 100-240 Vac, 500mA, O/P: 5Vdc,3000mA or 9Vdc,1600mA or 12Vdc,1200mA	
AC Adapter 1(EU)	Brand Name	Motorola (Salom)	Model Name SC-23
	Power Rating	I/P: 100-240 Vac, 500mA, O/P: 5Vdc,3000mA or 9Vdc,1600mA or 12Vdc,1200mA	
AC Adapter 1(UK)	Brand Name	Motorola (Salom)	Model Name SC-24
	Power Rating	I/P: 100-240 Vac, 500mA, O/P: 5Vdc,3000mA or 9Vdc,1600mA or 12Vdc,1200mA	
AC Adapter 1(IN)	Brand Name	Motorola (Salom)	Model Name SC-25
	Power Rating	I/P: 100-240 Vac, 500mA, O/P: 5Vdc,3000mA or 9Vdc,1600mA or 12Vdc,1200mA	
AC Adapter 1(AU)	Brand Name	Motorola (Salom)	Model Name SC-26
	Power Rating	I/P: 100-240 Vac, 500mA, O/P: 5Vdc,3000mA or 9Vdc,1600mA or 12Vdc,1200mA	
AC Adapter 1 (Indonesia)	Brand Name	Motorola (Salom)	Model Name SC-23
	Power Rating	I/P: 100-240 Vac, 500mA, O/P: 5Vdc,3000mA or 9Vdc,1600mA or 12Vdc,1200mA	
AC Adapter 2(US)	Brand Name	Motorola (Chenyang)	Model Name SC-22
	Power Rating	I/P: 100-240 Vac, 500mA, O/P: 5Vdc,3000mA or 9Vdc,1600mA or 12Vdc,1200mA	
AC Adapter 2(EU)	Brand Name	Motorola (Chenyang)	Model Name SC-23
	Power Rating	I/P: 100-240 Vac, 500mA, O/P: 5Vdc,3000mA or 9Vdc,1600mA or 12Vdc,1200mA	
AC Adapter 2(UK)	Brand Name	Motorola (Chenyang)	Model Name SC-24
	Power Rating	I/P: 100-240 Vac, 500mA, O/P: 5Vdc,3000mA or 9Vdc,1600mA or 12Vdc,1200mA	
AC Adapter 2(IN)	Brand Name	Motorola (Chenyang)	Model Name SC-25
	Power Rating	I/P: 100-240 Vac, 500mA, O/P: 5Vdc,3000mA or 9Vdc,1600mA or 12Vdc,1200mA	
AC Adapter 2(AU)	Brand Name	Motorola (Chenyang)	Model Name SC-26
	Power Rating	I/P: 100-240 Vac, 500mA, O/P: 5Vdc,3000mA or 9Vdc,1600mA or 12Vdc,1200mA	
Battery	Brand Name	Motorola (ATL)	Model Name JT40
	Power Rating	3.8Vdc,3200mAh	Type Li-ion Polymer
Earphone 1	Brand Name	Motorola (Jiahe)	Model Name LS-118M-12
	Signal Line Type	1.2 meter, non-shielded cable, without ferrite core	
Earphone 2	Brand Name	Motorola (Lianyun)	Model Name TS910A-38AMS01WHR-M
	Signal Line Type	1.2 meter, non-shielded cable, without ferrite core	
USB Cable	Brand Name	Motorola (Liqi)	Model Name L32B-053000100-ALL
	Signal Line Type	1.0 meter, shielded cable, without ferrite core	



1.7 Modification of EUT

No modifications are made to the EUT during all test items.

1.8 Testing Location

SPORTON INTERNATIONAL INC. is accredited to ISO 17025 by Taiwan Accreditation Foundation (TAF code : 1190) and the FCC designation No. TW1007 under the FCC-recognized accredited testing laboratories by Mutual Recognition Agreement (MRA) in FCC Test.

Test Site	SPORTON INTERNATIONAL INC.	
Test Site Location	No.58, Aly. 75, Ln. 564 Wenha 3rd Rd. Guishan Dist. Taoyuan City Taiwan TEL: +886-3-327-3456 FAX: +886-3-328-4978	
Test Site No.	Sporton Site No.	FCC Test Firm Registration No.
	03CH12-HY	214511

Note: The test site complies with ANSI C63.4 2014 requirement.

1.9 Applicable Standards

According to the specifications of the manufacturer, the EUT must comply with the requirements of the following standards:

- FCC Part 15 Subpart E
- FCC KDB 789033 D02 General UNII Test Procedures New Rules v02r01
- ANSI C63.10-2013

Remark:

1. All test items were verified and recorded according to the standards and without any deviation during the test.
2. This EUT has also been tested and complied with the requirements of FCC Part 15, Subpart B, recorded in a separate test report.



2 Test Configuration of Equipment Under Test

The EUT has been associated with peripherals and configuration operated in a manner tended to maximize its emission characteristics in a typical application. Frequency range investigated: radiated emission (9 kHz to the 10th harmonic of the highest fundamental frequency or to 40 GHz, whichever is lower). For radiated measurement, pre-scanned in three orthogonal panels, X, Y, Z. The worst cases were recorded in this report.

2.1 Carrier Frequency and Channel

Frequency Band	Channel	Freq. (MHz)	Channel	Freq. (MHz)
5745-5825 MHz Band 4 (U-NII-3)	149	5745	157	5785
	151*	5755	159*	5795
	153	5765	161	5805
	155#	5775	165	5825

Note:

1. The above Frequency and Channel in "*" were 802.11n HT40 and 802.11ac VHT40.
2. The above Frequency and Channel in "#n" were 802.11ac VHT80.



2.2 Test Mode

Final test mode of conducted test items and radiated spurious emissions are considering the modulation and worse data rates as below table.

Modulation	Data Rate
802.11a	6 Mbps
802.11n HT40	MCS0
802.11ac VHT20	MCS0
802.11ac VHT80	MCS0

Ch. #		Band IV : 5745-5825 MHz		
		802.11a	802.11n HT20	802.11n HT40
L	Low	149	149	151
M	Middle	157	157	-
H	High	165	165	159

Ch. #		Band IV : 5745-5825 MHz		
		802.11ac VHT20	802.11ac VHT40	802.11ac VHT80
L	Low	149	151	-
M	Middle	157	-	155
H	High	165	159	-

2.3 Connection Diagram of Test System

<WLAN Tx Mode>

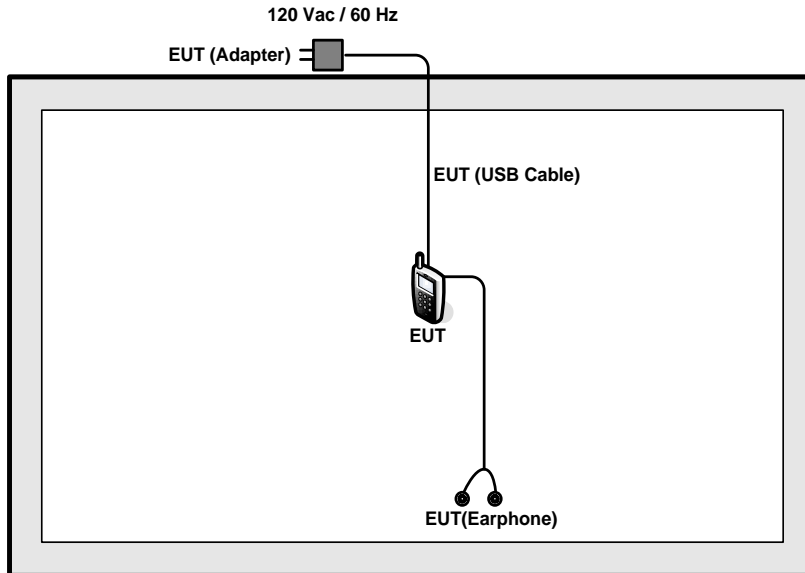

2.4 EUT Operation Test Setup

For WLAN RF test items, an engineering test program was provided and enabled to make EUT continuously transmit/receive.



3 Test Result

3.1 Unwanted Emissions Measurement

This section as specified in FCC Part 15.407(b) is to measure unwanted emissions through radiated measurement for band edge spurious emissions and out of band emissions measurement. The unwanted emissions shall comply with 15.407(b)(1) to (6), and restricted bands per FCC Part15.205.

3.1.1 Limit of Unwanted Emissions

(1) For transmitters operating in the 5.725-5.85 GHz band:

15.407(b)(4)(i) All emissions shall be limited to a level of -27 dBm/MHz at 75 MHz or more above or below the band edge increasing linearly to 10 dBm/MHz at 25 MHz above or below the band edge, and from 25 MHz above or below the band edge increasing linearly to a level of 15.6 dBm/MHz at 5 MHz above or below the band edge, and from 5 MHz above or below the band edge increasing linearly to a level of 27 dBm/MHz at the band edge.

(2) Unwanted spurious emissions fallen in restricted bands per FCC Part15.205 shall comply with the general field strength limits set forth in § 15.209 as below table,

Frequency (MHz)	Field Strength (microvolts/meter)	Measurement Distance (meters)
0.009 – 0.490	2400/F(kHz)	300
0.490 – 1.705	24000/F(kHz)	30
1.705 – 30.0	30	30
30 – 88	100	3
88 – 216	150	3
216 - 960	200	3
Above 960	500	3

Note: The following formula is used to convert the EIRP to field strength.

$$E = \frac{1000000\sqrt{30P}}{3} \mu\text{V/m, where P is the eirp (Watts)}$$



EIRP (dBm)	Field Strength at 3m (dBµV/m)
-17	78.3
- 27	68.3

(3) KDB789033 D02 v01r04 G)2)c)

- (i) Section 15.407(b)(1) to (b)(3) specify the unwanted emission limits for the U-NII-1 and U-NII-2 bands. As specified, emissions above 1000 MHz that are outside of the restricted bands are subject to a peak emission limit of -27 dBm/MHz.³
- (ii) Section 15.407(b)(4) specifies the unwanted emission limit for the U-NII-3 band. A band emissions mask is specified in Section 15.407(b)(4)(i). The emission limits are in terms of a Peak detector. An alternative to the band emissions mask is specified in Section 15.407(b)(4)(ii). The alternative limits are based on the highest antenna gain specified in the filing. There are also marketing and importation restrictions for the devices using the alternative limit.⁴

Note 3: An out-of-band emission that complies with both the average and peak limits of Section 15.209 is not required to satisfy the -27 dBm/MHz peak emission limit.

Note 4: Only devices with antenna gains of 10 dBi or less may be approved using the emission limits specified in Section 15.247(d) till March 2, 2018; all other devices operating in this band must use the mask specified in Section 15.407(b)(4)(i).



3.1.2 Measuring Instruments

The measuring equipment is listed in the section 4 of this test report.

3.1.3 Test Procedures

1. The testing follows FCC KDB 789033 D02 General UNII Test Procedures New Rules v01r04. Section G) Unwanted emissions measurement.

(1) Procedure for Unwanted Emissions Measurements Below 1000MHz

- RBW = 120 kHz
- VBW = 300 kHz
- Detector = Peak
- Trace mode = max hold

(2) Procedure for Peak Unwanted Emissions Measurements Above 1000 MHz

- RBW = 1 MHz
- VBW \geq 3 MHz
- Detector = Peak
- Sweep time = auto
- Trace mode = max hold

(3) Procedures for Average Unwanted Emissions Measurements Above 1000MHz

- RBW = 1 MHz
- VBW = 10 Hz, when duty cycle is no less than 98 percent.
- VBW \geq 1/T, when duty cycle is less than 98 percent where T is the minimum transmission duration over which the transmitter is on and is transmitting at its maximum power control level for the tested mode of operation.



2. The EUT was placed on a turntable with 0.8 meter for frequency below 1GHz and 1.5 meter for frequency above 1GHz respectively above ground.
3. The EUT was set 3 meters from the interference receiving antenna which was mounted on the top of a variable height antenna tower.
4. The antenna is a broadband antenna and its height is adjusted between one meter and four meters above ground to find the maximum value of the field strength for both horizontal polarization and vertical polarization of the antenna.
5. For each suspected emission, the EUT was arranged to its worst case and then adjust the antenna tower (from 1 m to 4 m) and turntable (from 0 degree to 360 degrees) to find the maximum reading.
6. For testing below 1GHz, if the emission level of the EUT in peak mode was 3 dB lower than the limit specified, then peak values of EUT will be reported, otherwise, the emissions will be repeated one by one using the CISPR quasi-peak method and reported.
7. For testing above 1GHz, the emission level of the EUT in peak mode was 20dB lower than average limit (that means the emission level in average mode also complies with the limit in average mode), then peak values of EUT will be reported, otherwise, the emissions will be measured in average mode again and reported.

3.1.4 Test Setup

For radiated emissions below 30MHz

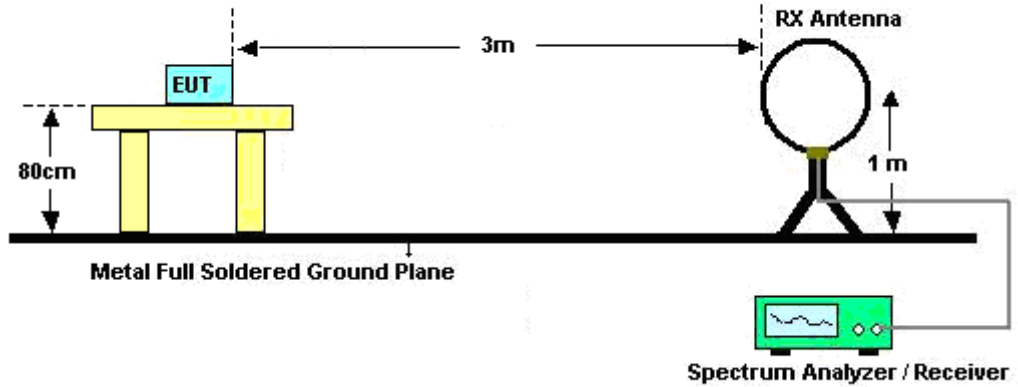

For radiated emissions from 30MHz to 1GHz

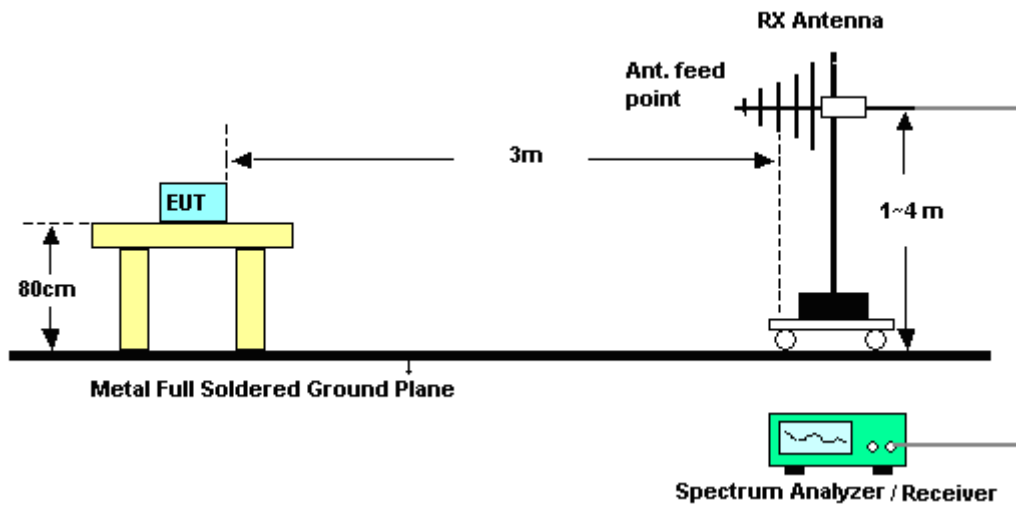

For radiated emissions above 1GHz

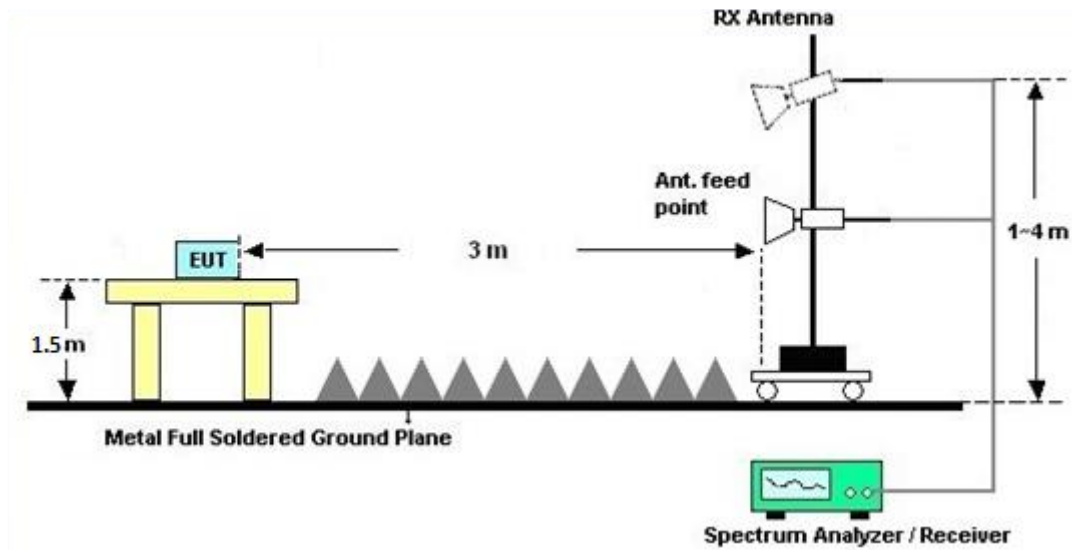

3.1.5 Test Results of Radiated Spurious Emissions (9 kHz ~ 30 MHz)

The low frequency, which started from 9 kHz to 30MHz, was pre-scanned and the result which was 20dB lower than the limit line per 15.31(o) was not reported.

3.1.6 Test Result of Radiated Spurious at Band Edges

Please refer to Appendix A.

3.1.7 Duty Cycle

Please refer to Appendix B.

3.1.8 Test Result of Radiated Spurious Emissions (30MHz ~ 10th Harmonic)

Please refer to Appendix A.



4 List of Measuring Equipment

Instrument	Manufacturer	Model No.	Serial No.	Characteristics	Calibration Date	Test Date	Due Date	Remark
Amplifier	MITEQ	TTA1840-35-H G	1871923	18GHz~40GHz, VSWR : 2.5:1 max	Jul. 18, 2017	Feb. 09, 2018~ Feb. 13, 2018	Jul. 17, 2018	Radiation (03CH12-HY)
Bilog Antenna	TESEQ	CBL 6111D&N-6-06	35414&AT-N 0602	30MHz~1GHz	Oct. 14, 2017	Feb. 09, 2018~ Feb. 13, 2018	Oct. 13, 2018	Radiation (03CH12-HY)
Loop Antenna	Rohde & Schwarz	HFH2-Z2	100488	9 kHz~30 MHz	Nov. 23, 2017	Feb. 09, 2018~ Feb. 13, 2018	Nov. 22, 2018	Radiation (03CH12-HY)
EMI Test Receiver	Rohde & Schwarz	ESU26	100390	20Hz~26.5GHz	Dec. 25, 2017	Feb. 09, 2018~ Feb. 13, 2018	Dec. 24, 2018	Radiation (03CH12-HY)
Horn Antenna	SCHWARZBE CK	BBHA 9120D	9120D-1328	1GHz ~ 18GHz	Oct. 20, 2017	Feb. 09, 2018~ Feb. 13, 2018	Oct. 19, 2018	Radiation (03CH12-HY)
Hygrometer	TECPEL	DTM-303B	TP140349	N/A	Oct. 12, 2017	Feb. 09, 2018~ Feb. 13, 2018	Oct. 11, 2018	Radiation (03CH12-HY)
Preamplifier	COM-POWER	PA-103	161075	10MHz~1GHz	Mar. 23, 2017	Feb. 09, 2018~ Feb. 13, 2018	Mar. 22, 2018	Radiation (03CH12-HY)
Preamplifier	Keysight	83017A	MY53270148	1GHz~26.5GHz	Jan. 15, 2018	Feb. 09, 2018~ Feb. 13, 2018	Jan. 14, 2019	Radiation (03CH12-HY)
Filter	Wainwright	WLKS1200-12 SS	SN2	1.2G Low Pass	Mar. 24, 2017	Feb. 09, 2018~ Feb. 13, 2018	Mar. 23, 2018	Radiation (03CH12-HY)
Controller	EMEC	EM1000	N/A	Control Turn table & Ant Mast	NCR	Feb. 09, 2018~ Feb. 13, 2018	NCR	Radiation (03CH12-HY)
Antenna Mast	EMEC	AM-BS-4500-B	N/A	1m~4m	NCR	Feb. 09, 2018~ Feb. 13, 2018	NCR	Radiation (03CH12-HY)
Turn Table	EMEC	TT2000	N/A	0~360 Degree	NCR	Feb. 09, 2018~ Feb. 13, 2018	NCR	Radiation (03CH12-HY)
SHF-EHF Horn Antenna	SCHWARZBE CK	BBHA 9170	BBHA917057 6	18GHz ~ 40GHz	Apr. 27, 2017	Feb. 09, 2018~ Feb. 13, 2018	Apr. 26, 2018	Radiation (03CH12-HY)
Spectrum Analyzer	Keysight	N9010A	MY55370526	10Hz~44GHz	Mar. 15, 2017	Feb. 09, 2018~ Feb. 13, 2018	Mar. 14, 2018	Radiation (03CH12-HY)

NCR: No Calibration Required



5 Uncertainty of Evaluation

Uncertainty of Radiated Emission Measurement (30 MHz ~ 1000 MHz)

Measuring Uncertainty for a Level of Confidence of 95% ($U = 2Uc(y)$)	5.1dB
---	-------

Uncertainty of Radiated Emission Measurement (1000 MHz ~ 18000 MHz)

Measuring Uncertainty for a Level of Confidence of 95% ($U = 2Uc(y)$)	5.2dB
---	-------

Uncertainty of Radiated Emission Measurement (18000 MHz ~ 40000 MHz)

Measuring Uncertainty for a Level of Confidence of 95% ($U = 2Uc(y)$)	4.7dB
---	-------



Appendix A. Radiated Spurious Emission

Band 4 - 5725~5850MHz

WIFI 802.11a (Band Edge @ 3m)

WIFI Ant.	Note	Frequency	Level	Over Limit	Limit Line	Read Level	Antenna Factor	Path Loss	Preamp Factor	Ant Pos	Table Pos	Peak Avg.	Pol.
1		(MHz)	(dBμV/m)	(dB)	(dBμV/m)	(dBμV)	(dB/m)	(dB)	(dB)	(cm)	(deg)	(P/A)	(H/V)
802.11a CH 149 5745MHz		5649.4	49.94	-18.26	68.2	42.62	32.19	6.35	31.22	102	211	P	H
		5696.2	57.63	-44.77	102.4	50.25	32.27	6.36	31.25	102	211	P	H
		5711.4	59.13	-49.26	108.39	51.74	32.29	6.36	31.26	102	211	P	H
		5724.2	63	-57.38	120.38	55.58	32.31	6.37	31.26	102	211	P	H
	*	5745	108.66	-	-	101.22	32.34	6.37	31.27	102	211	P	H
	*	5745	98	-	-	90.56	32.34	6.37	31.27	102	211	A	H
		5640.6	49.52	-18.68	68.2	42.2	32.19	6.35	31.22	100	112	P	V
		5698.6	53.31	-50.86	104.17	45.93	32.27	6.36	31.25	100	112	P	V
		5719.4	55.99	-54.64	110.63	48.57	32.31	6.37	31.26	100	112	P	V
		5725	60.68	-61.52	122.2	53.26	32.31	6.37	31.26	100	112	P	V
	*	5745	105.82	-	-	98.38	32.34	6.37	31.27	100	112	P	V
	*	5745	95.45	-	-	88.01	32.34	6.37	31.27	100	112	A	V



WIFI Ant. 1	Note	Frequency (MHz)	Level (dBμV/m)	Over Limit (dB)	Limit Line (dBμV/m)	Read Level (dBμV)	Antenna Factor (dB/m)	Path Loss (dB)	Preamp Factor (dB)	Ant Pos (cm)	Table Pos (deg)	Peak Avg. (P/A)	Pol. (H/V)
		5642.2	50.02	-18.18	68.2	42.7	32.19	6.35	31.22	100	216	P	H
		5699.8	50.18	-54.87	105.05	42.8	32.27	6.36	31.25	100	216	P	H
		5719.8	52.96	-57.78	110.74	45.54	32.31	6.37	31.26	100	216	P	H
		5720.4	54.3	-57.41	111.71	46.88	32.31	6.37	31.26	100	216	P	H
	*	5785	109.14	-	-	101.66	32.39	6.38	31.29	100	216	P	H
	*	5785	98.23	-	-	90.75	32.39	6.38	31.29	100	216	A	H
		5850	51.23	-70.97	122.2	43.65	32.48	6.42	31.32	100	216	P	H
		5858.4	51.18	-58.67	109.85	43.58	32.51	6.42	31.33	100	216	P	H
		5909	50.38	-29.63	80.01	42.69	32.58	6.46	31.35	100	216	P	H
		5935.2	50.07	-18.13	68.2	42.36	32.6	6.48	31.37	100	216	P	H
		5646.2	49.54	-18.66	68.2	42.22	32.19	6.35	31.22	100	112	P	V
		5694.8	50.02	-51.35	101.37	42.64	32.27	6.36	31.25	100	112	P	V
		5719	50.55	-59.97	110.52	43.13	32.31	6.37	31.26	100	112	P	V
		5723.4	51.61	-66.94	118.55	44.19	32.31	6.37	31.26	100	112	P	V
	*	5785	106.17	-	-	98.69	32.39	6.38	31.29	100	112	P	V
	*	5785	95.27	-	-	87.79	32.39	6.38	31.29	100	112	A	V
		5850.6	51.79	-69.04	120.83	44.21	32.48	6.42	31.32	100	112	P	V
		5864	50.38	-57.9	108.28	42.77	32.51	6.43	31.33	100	112	P	V
		5891.2	50.23	-42.95	93.18	42.57	32.56	6.44	31.34	100	112	P	V
		5946.2	49.61	-18.59	68.2	41.87	32.63	6.48	31.37	100	112	P	V



WIFI Ant. 1	Note	Frequency (MHz)	Level (dBμV/m)	Over Limit (dB)	Limit Line (dBμV/m)	Read Level (dBμV)	Antenna Factor (dB/m)	Path Loss (dB)	Preamp Factor (dB)	Ant Pos (cm)	Table Pos (deg)	Peak Avg. (P/A)	Pol. (H/V)
802.11a CH 165 5825MHz	*	5825	108.43	-	-	100.89	32.46	6.39	31.31	100	215	P	H
	*	5825	97.53	-	-	89.99	32.46	6.39	31.31	100	215	A	H
		5850.4	58.07	-63.22	121.29	50.49	32.48	6.42	31.32	100	215	P	H
		5855.8	57.09	-53.49	110.58	49.48	32.51	6.42	31.32	100	215	P	H
		5875.4	52.51	-52.39	104.9	44.88	32.53	6.43	31.33	100	215	P	H
		5929.8	50.78	-17.42	68.2	43.06	32.6	6.47	31.35	100	215	P	H
	*	5825	105.47	-	-	97.93	32.46	6.39	31.31	100	111	P	V
	*	5825	94.66	-	-	87.12	32.46	6.39	31.31	100	111	A	V
		5852.2	55.78	-61.4	117.18	48.2	32.48	6.42	31.32	100	111	P	V
		5856.8	56.38	-53.92	110.3	48.77	32.51	6.42	31.32	100	111	P	V
		5882.2	52.08	-47.77	99.85	44.44	32.53	6.44	31.33	100	111	P	V
		5941.4	50.5	-17.7	68.2	42.76	32.63	6.48	31.37	100	111	P	V
Remark	1. No other spurious found. 2. All results are PASS against Peak and Average limit line.												



Band 4 5725~5850MHz
WIFI 802.11a (Harmonic @ 3m)

WIFI Ant. 1	Note	Frequency (MHz)	Level (dBμV/m)	Over Limit (dB)	Limit Line (dBμV/m)	Read Level (dBμV)	Antenna Factor (dB/m)	Path Loss (dB)	Preamp Factor (dB)	Ant Pos (cm)	Table Pos (deg)	Peak Avg. (P/A)	Pol. (H/V)
802.11a CH 149 5745MHz		11490	57.42	-16.58	74	72.37	40.11	10.33	65.39	118	280	P	H
		11490	42.52	-11.48	54	57.47	40.11	10.33	65.39	118	280	A	H
		17235	50.7	-17.5	68.2	60.7	41.54	12.73	64.27	100	0	P	H
		11490	64.15	-9.85	74	79.1	40.11	10.33	65.39	123	348	P	V
		11490	49.62	-4.38	54	64.57	40.11	10.33	65.39	123	348	A	V
		17235	49.38	-18.82	68.2	59.38	41.54	12.73	64.27	100	0	P	V
802.11a CH 157 5785MHz		11570	56.72	-17.28	74	71.79	39.93	10.37	65.37	119	286	P	H
		11570	42.17	-11.83	54	57.24	39.93	10.37	65.37	119	286	A	H
		17355	48.59	-19.61	68.2	57.92	41.96	12.82	64.11	100	0	P	H
		11570	64.81	-9.19	74	79.88	39.93	10.37	65.37	111	349	P	V
		11570	50.6	-3.4	54	65.67	39.93	10.37	65.37	111	349	A	V
		17355	48.02	-20.18	68.2	57.35	41.96	12.82	64.11	100	0	P	V
802.11a CH 165 5825MHz		11650	57.87	-16.13	74	73.03	39.77	10.41	65.34	120	281	P	H
		11650	44	-10	54	59.16	39.77	10.41	65.34	120	281	A	H
		17475	46.94	-21.26	68.2	55.6	42.38	12.91	63.95	100	0	P	H
		11650	65.13	-8.87	74	80.29	39.77	10.41	65.34	113	348	P	V
		11650	50.89	-3.11	54	66.05	39.77	10.41	65.34	113	348	A	V
		17475	47.28	-20.92	68.2	55.94	42.38	12.91	63.95	100	0	P	V
Remark	1. No other spurious found. 2. All results are PASS against Peak and Average limit line.												



Band 4 5725~5850MHz
WIFI 802.11n HT40 (Band Edge @ 3m)

Table with 14 columns: WIFI Ant. 1, Note, Frequency (MHz), Level (dBµV/m), Over Limit (dB), Limit Line (dBµV/m), Read Level (dBµV), Antenna Factor (dB/m), Path Loss (dB), Preamp Factor (dB), Ant Pos (cm), Table Pos (deg), Peak Avg. (P/A), Pol. (H/V). Rows include frequency measurements from 5624.4 to 5937.2 MHz.



WIFI Ant. 1	Note	Frequency (MHz)	Level (dBμV/m)	Over Limit (dB)	Limit Line (dBμV/m)	Read Level (dBμV)	Antenna Factor (dB/m)	Path Loss (dB)	Preamp Factor (dB)	Ant Pos (cm)	Table Pos (deg)	Peak Avg. (P/A)	Pol. (H/V)
802.11n HT40 CH 159 5795MHz		5634.2	50.3	-17.9	68.2	42.98	32.19	6.35	31.22	100	214	P	H
		5696.8	51.05	-51.79	102.84	43.67	32.27	6.36	31.25	100	214	P	H
		5718.2	53.46	-56.84	110.3	46.04	32.31	6.37	31.26	100	214	P	H
		5724.4	54.45	-66.38	120.83	47.03	32.31	6.37	31.26	100	214	P	H
	*	5795	104.63	-	-	97.13	32.41	6.38	31.29	100	214	P	H
	*	5795	93.61	-	-	86.11	32.41	6.38	31.29	100	214	A	H
		5852.4	53.6	-63.13	116.73	46.02	32.48	6.42	31.32	100	214	P	H
		5856.6	53.26	-57.09	110.35	45.65	32.51	6.42	31.32	100	214	P	H
		5875	50.68	-54.52	105.2	43.05	32.53	6.43	31.33	100	214	P	H
		5927.8	49.21	-18.99	68.2	41.49	32.6	6.47	31.35	100	214	P	H
		5605.4	49.46	-18.74	68.2	42.19	32.14	6.34	31.21	100	107	P	V
		5683.4	50.11	-42.84	92.95	42.76	32.24	6.36	31.25	100	107	P	V
		5713.2	51.23	-57.67	108.9	43.84	32.29	6.36	31.26	100	107	P	V
		5724.2	51.38	-69	120.38	43.96	32.31	6.37	31.26	100	107	P	V
	*	5795	101.48	-	-	93.98	32.41	6.38	31.29	100	107	P	V
	*	5795	90.86	-	-	83.36	32.41	6.38	31.29	100	107	A	V
		5851.2	52.06	-67.4	119.46	44.48	32.48	6.42	31.32	100	107	P	V
		5857.6	51.07	-59	110.07	43.46	32.51	6.42	31.32	100	107	P	V
	5900.6	50.45	-35.77	86.22	42.77	32.56	6.46	31.34	100	107	P	V	
	5931	49.16	-19.04	68.2	41.44	32.6	6.47	31.35	100	107	P	V	
Remark	1. No other spurious found. 2. All results are PASS against Peak and Average limit line.												



Band 4 5725~5850MHz
WIFI 802.11n HT40 (Harmonic @ 3m)

Table with 14 columns: WIFI Ant. 1, Note, Frequency (MHz), Level (dBµV/m), Over Limit (dB), Limit Line (dBµV/m), Read Level (dBµV), Antenna Factor (dB/m), Path Loss (dB), Preamp Factor (dB), Ant Pos (cm), Table Pos (deg), Peak Avg. (P/A), Pol. (H/V). Rows include data for 802.11n HT40 CH 151 5755MHz and 802.11n HT40 CH 159 5795MHz.

Remark

- 1. No other spurious found.
2. All results are PASS against Peak and Average limit line.



Band 4 5725~5850MHz
WIFI 802.11ac VHT20 (Band Edge @ 3m)

Table with 14 columns: WIFI Ant. 1, Note, Frequency (MHz), Level (dBµV/m), Over Limit (dB), Limit Line (dBµV/m), Read Level (dBµV), Antenna Factor (dB/m), Path Loss (dB), Preamp Factor (dB), Ant Pos (cm), Table Pos (deg), Peak Avg. (P/A), Pol. (H/V). Rows include frequencies like 5647, 5693, 5716, 5724.6, 5745, 5745, 5609.6, 5698.6, 5716.6, 5723.2, 5745, 5745.



WIFI Ant. 1	Note	Frequency (MHz)	Level (dBμV/m)	Over Limit (dB)	Limit Line (dBμV/m)	Read Level (dBμV)	Antenna Factor (dB/m)	Path Loss (dB)	Preamp Factor (dB)	Ant Pos (cm)	Table Pos (deg)	Peak Avg. (P/A)	Pol. (H/V)
		5639.2	49.68	-18.52	68.2	42.36	32.19	6.35	31.22	118	217	P	H
		5687.8	51.19	-45.01	96.2	43.81	32.27	6.36	31.25	118	217	P	H
		5716.8	52.98	-56.93	109.91	45.59	32.29	6.36	31.26	118	217	P	H
		5722.2	52.91	-62.91	115.82	45.49	32.31	6.37	31.26	118	217	P	H
	*	5785	108.58	-	-	101.1	32.39	6.38	31.29	118	217	P	H
	*	5785	97.72	-	-	90.24	32.39	6.38	31.29	118	217	A	H
		5851	50.56	-69.36	119.92	42.98	32.48	6.42	31.32	118	217	P	H
		5861.6	51.25	-57.7	108.95	43.64	32.51	6.43	31.33	118	217	P	H
802.11ac		5918.8	50.12	-22.65	72.77	42.42	32.58	6.47	31.35	118	217	P	H
VHT20		5932.8	49.93	-18.27	68.2	42.21	32.6	6.47	31.35	118	217	P	H
CH 157		5609	49.26	-18.94	68.2	41.99	32.14	6.34	31.21	100	107	P	V
5785MHz		5686	49.93	-44.94	94.87	42.55	32.27	6.36	31.25	100	107	P	V
		5717	50.62	-59.34	109.96	43.23	32.29	6.36	31.26	100	107	P	V
		5721.8	50.73	-64.17	114.9	43.31	32.31	6.37	31.26	100	107	P	V
	*	5785	105.82	-	-	98.34	32.39	6.38	31.29	100	107	P	V
	*	5785	94.78	-	-	87.3	32.39	6.38	31.29	100	107	A	V
		5850	50.65	-71.55	122.2	43.07	32.48	6.42	31.32	100	107	P	V
		5858.8	49.98	-59.75	109.73	42.38	32.51	6.42	31.33	100	107	P	V
		5917.2	49.52	-24.43	73.95	41.82	32.58	6.47	31.35	100	107	P	V
		5944.6	49.67	-18.53	68.2	41.93	32.63	6.48	31.37	100	107	P	V



WIFI Ant. 1	Note	Frequency (MHz)	Level (dBμV/m)	Over Limit (dB)	Limit Line (dBμV/m)	Read Level (dBμV)	Antenna Factor (dB/m)	Path Loss (dB)	Preamp Factor (dB)	Ant Pos (cm)	Table Pos (deg)	Peak Avg. (P/A)	Pol. (H/V)
802.11ac VHT20 CH 165 5825MHz	*	5825	108.12	-	-	100.58	32.46	6.39	31.31	102	215	P	H
	*	5825	97.07	-	-	89.53	32.46	6.39	31.31	102	215	A	H
		5852	57.97	-59.67	117.64	50.39	32.48	6.42	31.32	102	215	P	H
		5857	55.15	-55.09	110.24	47.54	32.51	6.42	31.32	102	215	P	H
		5875	51.24	-53.96	105.2	43.61	32.53	6.43	31.33	102	215	P	H
		5927	49.62	-18.58	68.2	41.9	32.6	6.47	31.35	102	215	P	H
	*	5825	105.63	-	-	98.09	32.46	6.39	31.31	111	107	P	V
	*	5825	94.43	-	-	86.89	32.46	6.39	31.31	111	107	A	V
		5850.2	55.07	-66.67	121.74	47.49	32.48	6.42	31.32	111	107	P	V
		5856.6	53.46	-56.89	110.35	45.85	32.51	6.42	31.32	111	107	P	V
	5879.2	50.72	-51.36	102.08	43.09	32.53	6.43	31.33	111	107	P	V	
	5947	49.07	-19.13	68.2	41.33	32.63	6.48	31.37	111	107	P	V	
Remark	<ol style="list-style-type: none"> No other spurious found. All results are PASS against Peak and Average limit line. 												



Band 4 5725~5850MHz
WIFI 802.11ac VHT20 (Harmonic @ 3m)

WIFI Ant. 1	Note	Frequency (MHz)	Level (dBμV/m)	Over Limit (dB)	Limit Line (dBμV/m)	Read Level (dBμV)	Antenna Factor (dB/m)	Path Loss (dB)	Preamp Factor (dB)	Ant Pos (cm)	Table Pos (deg)	Peak Avg. (P/A)	Pol. (H/V)
802.11ac VHT20 CH 149 5745MHz		11490	58.7	-15.3	74	73.65	40.11	10.33	65.39	119	278	P	H
		11490	42.63	-11.37	54	57.58	40.11	10.33	65.39	119	278	A	H
		17235	49.95	-18.25	68.2	59.95	41.54	12.73	64.27	100	0	P	H
		11490	66.27	-7.73	74	81.22	40.11	10.33	65.39	120	348	P	V
		11490	49.93	-4.07	54	64.88	40.11	10.33	65.39	120	348	A	V
		17235	49.26	-18.94	68.2	59.26	41.54	12.73	64.27	100	0	P	V
802.11ac VHT20 CH 157 5785MHz		11570	57.59	-16.41	74	72.66	39.93	10.37	65.37	118	286	P	H
		11570	41.96	-12.04	54	57.03	39.93	10.37	65.37	118	286	A	H
		17355	49.09	-19.11	68.2	58.42	41.96	12.82	64.11	100	0	P	H
		11570	65.88	-8.12	74	80.95	39.93	10.37	65.37	117	349	P	V
		11570	49.82	-4.18	54	64.89	39.93	10.37	65.37	117	349	A	V
		17355	48.9	-19.3	68.2	58.23	41.96	12.82	64.11	100	0	P	V
802.11ac VHT20 CH 165 5825MHz		11650	59.48	-14.52	74	74.64	39.77	10.41	65.34	119	280	P	H
		11650	43.67	-10.33	54	58.83	39.77	10.41	65.34	119	280	A	H
		17475	47.57	-20.63	68.2	56.23	42.38	12.91	63.95	100	0	P	H
		11650	66.35	-7.65	74	81.51	39.77	10.41	65.34	110	352	P	V
		11650	50.5	-3.5	54	65.66	39.77	10.41	65.34	110	352	A	V
		17475	46.64	-21.56	68.2	55.3	42.38	12.91	63.95	100	0	P	V
Remark	1. No other spurious found. 2. All results are PASS against Peak and Average limit line.												



Band 4 5725~5850MHz
WIFI 802.11ac VHT80 (Band Edge @ 3m)

WIFI Ant. 1	Note	Frequency (MHz)	Level (dBμV/m)	Over Limit (dB)	Limit Line (dBμV/m)	Read Level (dBμV)	Antenna Factor (dB/m)	Path Loss (dB)	Preamp Factor (dB)	Ant Pos (cm)	Table Pos (deg)	Peak Avg. (P/A)	Pol. (H/V)
802.11ac VHT80 CH 155 5775MHz		5644.6	49.98	-18.22	68.2	42.66	32.19	6.35	31.22	103	215	P	H
		5696.6	58.06	-44.63	102.69	50.68	32.27	6.36	31.25	103	215	P	H
		5718.4	61.11	-49.24	110.35	53.69	32.31	6.37	31.26	103	215	P	H
		5720.2	62.34	-48.92	111.26	54.92	32.31	6.37	31.26	103	215	P	H
	*	5775	101.06	-	-	93.57	32.39	6.38	31.28	103	215	P	H
	*	5775	90.1	-	-	82.61	32.39	6.38	31.28	103	215	A	H
		5850.2	58.23	-63.51	121.74	50.65	32.48	6.42	31.32	103	215	P	H
		5858.4	57.42	-52.43	109.85	49.82	32.51	6.42	31.33	103	215	P	H
		5875.6	51.93	-52.82	104.75	44.3	32.53	6.43	31.33	103	215	P	H
		5932.4	49.93	-18.27	68.2	42.21	32.6	6.47	31.35	103	215	P	H
		5640.6	49.18	-19.02	68.2	41.86	32.19	6.35	31.22	100	106	P	V
		5698.6	55.15	-49.02	104.17	47.77	32.27	6.36	31.25	100	106	P	V
		5720	57.38	-53.42	110.8	49.96	32.31	6.37	31.26	100	106	P	V
		5720.2	58.42	-52.84	111.26	51	32.31	6.37	31.26	100	106	P	V
	*	5775	97.59	-	-	90.1	32.39	6.38	31.28	100	106	P	V
	*	5775	87.23	-	-	79.74	32.39	6.38	31.28	100	106	A	V
		5851	56.6	-63.32	119.92	49.02	32.48	6.42	31.32	100	106	P	V
		5855.8	55.32	-55.26	110.58	47.71	32.51	6.42	31.32	100	106	P	V
		5880	51.06	-50.43	101.49	43.42	32.53	6.44	31.33	100	106	P	V
	5939.4	49.8	-18.4	68.2	42.06	32.63	6.48	31.37	100	106	P	V	

Remark

- No other spurious found.
- All results are PASS against Peak and Average limit line.



Band 4 5725~5850MHz

WIFI 802.11ac VHT80 (Harmonic @ 3m)

WIFI Ant. 1	Note	Frequency (MHz)	Level (dBμV/m)	Over Limit (dB)	Limit Line (dBμV/m)	Read Level (dBμV)	Antenna Factor (dB/m)	Path Loss (dB)	Preamp Factor (dB)	Ant Pos (cm)	Table Pos (deg)	Peak Avg. (P/A)	Pol. (H/V)
802.11ac		11550	46.72	-27.28	74	61.76	39.98	10.36	65.38	100	0	P	H
VHT80		17325	48.26	-19.94	68.2	57.79	41.84	12.79	64.16	100	0	P	H
CH 155		11550	49.96	-24.04	74	65	39.98	10.36	65.38	100	0	P	V
5775MHz		17325	48.33	-19.87	68.2	57.86	41.84	12.79	64.16	100	0	P	V
Remark	1. No other spurious found. 2. All results are PASS against Peak and Average limit line.												



Emission below 1GHz
5GHz WIFI 802.11a (LF @ 3m)

WIFI	Note	Frequency	Level	Over	Limit	Read	Antenna	Path	Preamp	Ant	Table	Peak	Pol.
Ant.				Limit	Line	Level	Factor	Loss	Factor	Pos	Pos	Avg.	
1		(MHz)	(dBμV/m)	(dB)	(dBμV/m)	(dBμV)	(dB/m)	(dB)	(dB)	(cm)	(deg)	(P/A)	(H/V)
5GHz 802.11a LF		80.22	14.98	-25.02	40	31.39	13.19	0.82	30.42	-	-	P	H
		177.42	25.5	-18	43.5	39.66	14.88	1.26	30.3	-	-	P	H
		298.65	22.66	-23.34	46	32.25	19.06	1.49	30.14	-	-	P	H
		458.9	27.4	-18.6	46	32.35	23.13	1.79	29.87	-	-	P	H
		763.4	30.83	-15.17	46	29.97	27.92	2.35	29.41	100	0	P	H
		991.6	34.51	-19.49	54	30.04	30.68	2.77	28.98	-	-	P	H
		34.05	31.73	-8.27	40	39.2	22.31	0.45	30.23	100	0	P	V
		179.04	20.73	-22.77	43.5	34.98	14.79	1.26	30.3	-	-	P	V
		271.92	21.1	-24.9	46	30.7	19.13	1.45	30.18	-	-	P	V
		447	27.28	-18.72	46	32.49	22.92	1.76	29.89	-	-	P	V
		729.1	32.98	-13.02	46	32.91	27.27	2.28	29.48	-	-	P	V
	962.2	34.84	-19.16	54	30.02	31.12	2.74	29.04	-	-	P	V	
Remark	1. No other spurious found. 2. All results are PASS against limit line.												



Note symbol

*	Fundamental Frequency which can be ignored. However, the level of any unwanted emissions shall not exceed the level of the fundamental frequency.
!	Test result is over limit line.
P/A	Peak or Average
H/V	Horizontal or Vertical



A calculation example for radiated spurious emission is shown as below:

WIFI	Note	Frequency	Level	Over	Limit	Read	Antenna	Path	Preamp	Ant	Table	Peak	Pol.
Ant.				Limit	Line	Level	Factor	Loss	Factor	Pos	Pos	Avg.	
1		(MHz)	(dBμV/m)	(dB)	(dBμV/m)	(dBμV)	(dB/m)	(dB)	(dB)	(cm)	(deg)	(P/A)	(H/V)
802.11b		2390	55.45	-18.55	74	54.51	32.22	4.58	35.86	103	308	P	H
CH 01													
2412MHz		2390	43.54	-10.46	54	42.6	32.22	4.58	35.86	103	308	A	H

1. Path Loss(dB) = Cable loss(dB) + Filter loss(dB) + Attenuator loss(dB)
2. Level(dBμV/m) = Antenna Factor(dB/m) + Path Loss(dB) + Read Level(dBμV) - Preamp Factor(dB)
3. Over Limit(dB) = Level(dBμV/m) – Limit Line(dBμV/m)

For Peak Limit @ 2390MHz:

1. Level(dBμV/m)
= Antenna Factor(dB/m) + Path Loss(dB) + Read Level(dBμV) - Preamp Factor(dB)
= 32.22(dB/m) + 4.58(dB) + 54.51(dBμV) – 35.86 (dB)
= 55.45 (dBμV/m)
2. Over Limit(dB)
= Level(dBμV/m) – Limit Line(dBμV/m)
= 55.45(dBμV/m) – 74(dBμV/m)
= -18.55(dB)

For Average Limit @ 2390MHz:

1. Level(dBμV/m)
= Antenna Factor(dB/m) + Path Loss(dB) + Read Level(dBμV) - Preamp Factor(dB)
= 32.22(dB/m) + 4.58(dB) + 42.6(dBμV) – 35.86 (dB)
= 43.54 (dBμV/m)
2. Over Limit(dB) = Level(dBμV/m) – Limit Line(dBμV/m)
= 43.54(dBμV/m) – 54(dBμV/m)
= -10.46(dB)

Both peak and average measured complies with the limit line, so test result is “PASS”.



Appendix B. Duty Cycle Plots

Band	Duty Cycle(%)	T(ms)	1/T(kHz)	VBW Setting
802.11a	94.85	2.067	0.484	1 kHz
802.11n HT40	89.59	0.952	1.051	3 kHz
802.11ac VHT20	94.90	1.939	0.516	1 kHz
802.11ac VHT80	83.81	0.465	2.152	3 kHz

802.11a

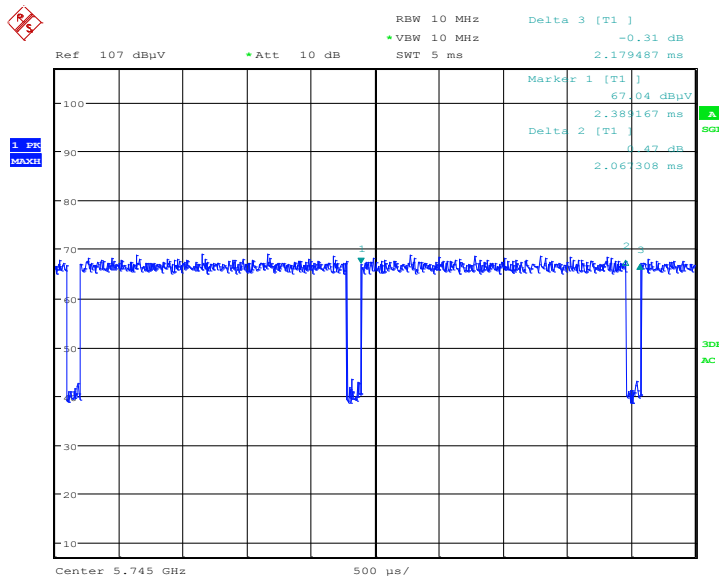



802.11n HT40

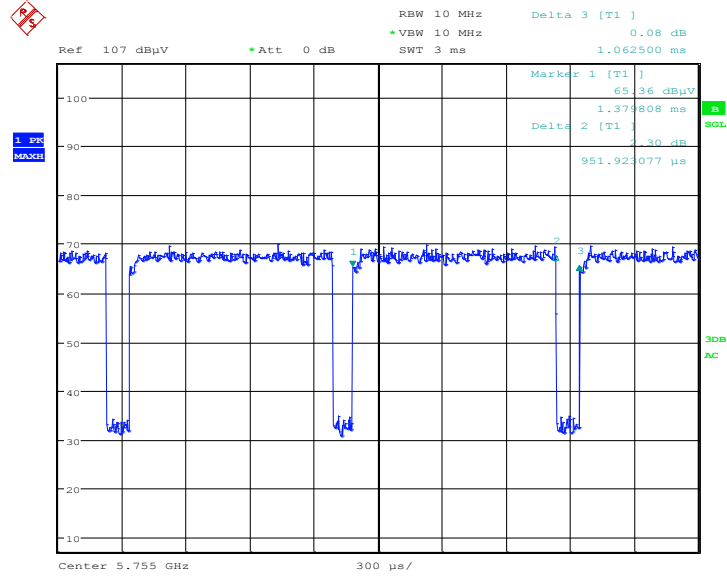

Date: 10.FEB.2018 16:51:37

802.11ac VHT20

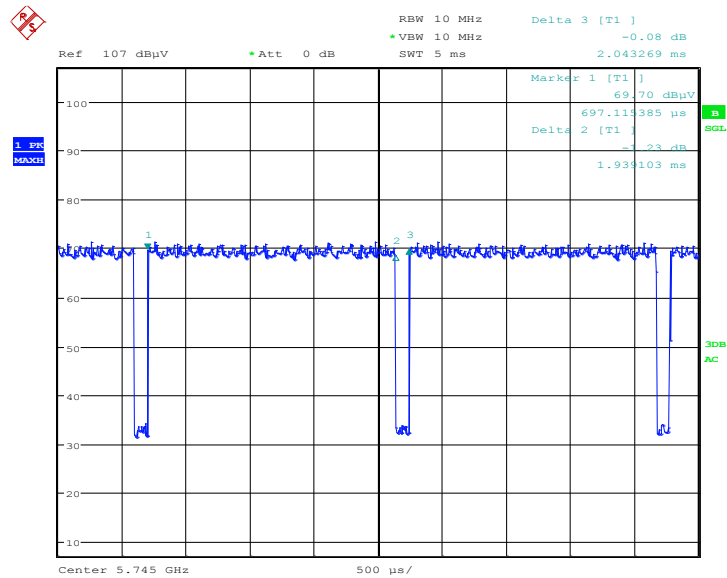

Date: 10.FEB.2018 15:06:54



802.11ac VHT80

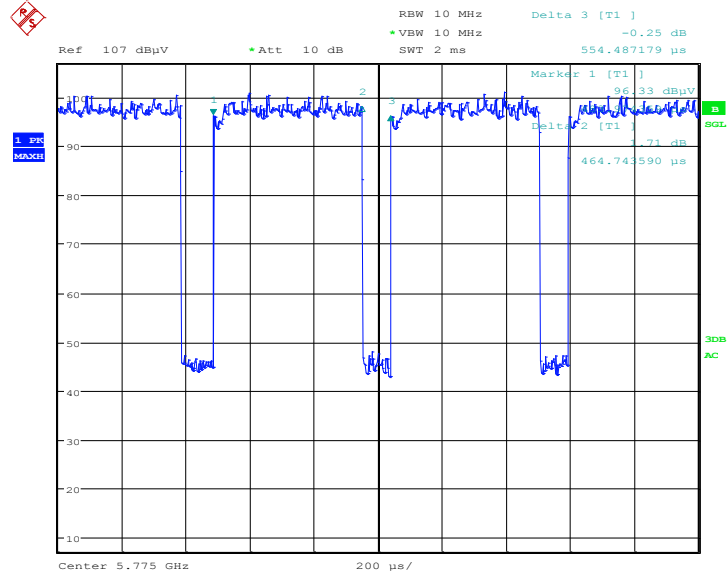

Date: 10.FEB.2018 17:54:34



Appendix D. Reference Report

Please refer to Sporton report number FR7D2702F which is issued separately.