



FCC RF Test Report

APPLICANT : Motorola Mobility LLC
EQUIPMENT : Mobile Cellular Phone
BRAND NAME : Motorola
MODEL NAME : 10012
FCC ID : IHDT56WH1
STANDARD : FCC Part 15 Subpart E §15.407
CLASSIFICATION : (NII) Unlicensed National Information Infrastructure

The product was received on Jun. 02, 2017 and testing was completed on Jun. 22, 2017. We, Sporton International (KunShan) INC., would like to declare that the tested sample has been evaluated in accordance with the test procedures and has been in compliance with the applicable technical standards.

The test results in this report apply exclusively to the tested model / sample. Without written approval of Sporton International (KunShan) INC., the test report shall not be reproduced except in full.

Prepared by: James Huang / Manager



Approved by: Jones Tsai / Manager

Sporton International (KunShan) INC.
No.3-2, Pingxiang Road, Kunshan Development Zone, Jiangsu, China



TABLE OF CONTENTS

1 GENERAL DESCRIPTION 5

1.1 Applicant 5

1.2 Manufacturer 5

1.3 Product Feature of Equipment Under Test 5

1.4 Product Specification of Equipment Under Test 6

1.5 Specification of Accessory 7

1.6 Modification of EUT 7

1.7 Testing Location 8

1.8 Applicable Standards 8

2 TEST CONFIGURATION OF EQUIPMENT UNDER TEST 9

2.1 Carrier Frequency Channel 9

2.2 Test Mode 10

2.3 Connection Diagram of Test System 12

2.4 Support Unit used in test configuration and system 13

2.5 EUT Operation Test Setup 13

2.6 Measurement Results Explanation Example 13

3 TEST RESULT 14

3.1 26dB & 99% Occupied Bandwidth Measurement 14

3.2 Maximum Conducted Output Power Measurement 16

3.3 Power Spectral Density Measurement 18

3.4 Unwanted Radiated Emission Measurement 21

3.5 AC Conducted Emission Measurement 27

3.6 Frequency Stability Measurement 31

3.7 Automatically Discontinue Transmission 32

3.8 Antenna Requirements 33

4 LIST OF MEASURING EQUIPMENTS 34

5 UNCERTAINTY OF EVALUATION 35

APPENDIX A. CONDUCTED TEST RESULTS

APPENDIX B. RADIATED SPURIOUS EMISSION

APPENDIX C. DUTY CYCLE PLOTS

APPENDIX D. SETUP PHOTOGRAPHS



SUMMARY OF TEST RESULT

Report Section	FCC Rule	Description	Limit	Result	Remark
3.1	2.1049 15.403(i)	26dB & 99% Bandwidth	-	Pass	-
3.2	15.407(a)	Maximum Conducted Output Power	FCC ≤ 24 dBm (depend on band)	Pass	-
3.3	15.407(a)	Power Spectral Density	FCC ≤ 11 dBm/MHz (depend on band)	Pass	-
3.4	15.407(b)	Unwanted Emissions	15.407(b) 15.209(a)	Pass	Under limit 3.77 dB at 5150.00 MHz
3.5	15.207	AC Conducted Emission	15.207(a)	Pass	Under limit 12.96 dB at 0.582 MHz
3.6	15.407(g)	Frequency Stability	Within Operation Band	Pass	-
3.7	15.407(c)	Automatically Discontinue Transmission	Discontinue Transmission	Pass	-
3.8	15.203 & 15.407(a)	Antenna Requirement	N/A	Pass	-



1 General Description

1.1 Applicant

Motorola Mobility LLC
222 W, Merchandise Mart Plaza, Chicago IL 60654 USA

1.2 Manufacturer

Motorola Mobility LLC
222 W, Merchandise Mart Plaza, Chicago IL 60654 USA

1.3 Product Feature of Equipment Under Test

Product Feature	
Equipment	Mobile Cellular Phone
Brand Name	Motorola
Model Name	10012
FCC ID	IHDT56WH1
EUT supports Radios application	GSM/GPRS/EGPRS/WCDMA/HSPA/DC-HSDPA/ HSPA+(16QAM uplink is not supported)/LTE/ WLAN 2.4GHz 802.11b/g/n HT20/ WLAN 5GHz 802.11a/n HT20/HT40/ Bluetooth v3.0 + EDR/Bluetooth v4.0 LE/ Bluetooth v4.1 LE/ Bluetooth v4.2 LE
IMEI Code	Conducted: 355666080013534 Conduction: 355666080014854 Radiation: 355666080014938
HW Version	NA DVT2
SW Version	sanders_oem_userdebug_7.1.1_NPS26.116-26_47_intcfg-t est-keys_oem
EUT Stage	Identical Prototype

Remark:

1. The above EUT's information was declared by manufacturer. Please refer to the specifications or user's manual for more detailed description.



1.4 Product Specification of Equipment Under Test

Standards-related Product Specification	
Tx/Rx Frequency Range	5180 MHz ~ 5240 MHz 5260 MHz ~ 5320 MHz 5500 MHz ~ 5700 MHz
Maximum Output Power to Antenna	<5180 MHz ~ 5240 MHz> 802.11a : 13.59 dBm / 0.0229 W 802.11n HT20 : 13.69 dBm / 0.0234 W 802.11n HT40 : 14.12 dBm / 0.0258 W <5260 MHz ~ 5320 MHz> 802.11a : 13.46 dBm / 0.0222 W 802.11n HT20 : 13.30 dBm / 0.0214 W 802.11n HT40 : 14.13 dBm / 0.0259 W <5500 MHz ~ 5700 MHz > 802.11a : 13.31 dBm / 0.0214 W 802.11n HT20 : 13.32 dBm / 0.0215 W 802.11n HT40 : 13.89 dBm / 0.0245 W
99% Occupied Bandwidth	<5180 MHz ~ 5240 MHz> 802.11a : 18.63 MHz 802.11n HT20 : 19.53 MHz 802.11n HT40 : 37.06 MHz <5260 MHz ~ 5320 MHz> 802.11a : 18.78 MHz 802.11n HT20 : 19.43 MHz 802.11n HT40 : 36.86 MHz <5500 MHz ~ 5700 MHz > 802.11a : 18.83 MHz 802.11n HT20 : 19.63 MHz 802.11n HT40 : 37.16 MHz
Antenna Type / Gain	<5180 MHz ~ 5240 MHz > IFA Antenna with gain -3.2 dBi <5260 MHz ~ 5320 MHz > IFA Antenna with gain -4.1 dBi <5500 MHz ~ 5700 MHz > IFA Antenna with gain -4.5 dBi
Type of Modulation	802.11a/n : OFDM (BPSK / QPSK / 16QAM / 64QAM)

Note: WLAN operation in 5600 MHz ~ 5650 MHz is notched.

1.5 Specification of Accessory

Specification of Accessory			
AC Adapter 1	Brand Name	Motorola(Salom)	Model Name SC-22
	Power Rating	I/P: 100-240Vac, 500mA, O/P: 5Vdc or 9Vdc or 12Vdc, 3000mA or 1600mA or 1200mA	
AC Adapter 2	Brand Name	Motorola(chenyang)	Model Name SC-22
	Power Rating	I/P: 100-240Vac, 500mA, O/P: 5Vdc or 9Vdc or 12Vdc, 3000mA or 1600mA or 1200mA	
AC Adapter 3	Brand Name	Motorola(LiteOn)	Model Name SC-22
	Power Rating	I/P: 100-240Vac, 500mA, O/P: 5Vdc or 9Vdc or 12Vdc, 3000mA or 1600mA or 1200mA	
Battery	Brand Name	Motorola (ATL)	Model Name HG30
	Power Rating	3.8Vdc,3000mAh	Type Li-ion, Polymer
Earphone 1	Brand Name	Motorola(JuWei)	Model Name JWEP0998-W09R
	Signal Line Type	1.2 meter, non-shielded cable, without ferrite core	
Earphone 2	Brand Name	Motorola(Newleader)	Model Name NLD-EM307K-02SF
	Signal Line Type	1.2 meter, non-shielded cable, without ferrite core	
USB Cable	Brand Name	Motorola(Saibao)	Model Name SWT-A075A
	Signal Line Type	1.0meter, shielded cable, without core	

1.6 Modification of EUT

No modifications are made to the EUT during all test items.



1.7 Testing Location

Test Site	Sporton International (KunShan) INC.			
Test Site Location	No.3-2, Pingxiang Road, Kunshan Development Zone, Jiangsu, China TEL: +86-0512-5790-0158 FAX: +86-0512-5790-0958			
Test Site No.	Sporton Site No.			FCC Registration No.
	TH01-KS	03CH03-KS	CO01-KS	306251

Note: The test site complies with ANSI C63.4 2014 requirement.

1.8 Applicable Standards

According to the specifications of the manufacturer, the EUT must comply with the requirements of the following standards:

- ♦ FCC Part 15 Subpart E
- ♦ FCC KDB 789033 D02 General UNII Test Procedures New Rules v01r04
- ♦ ANSI C63.10-2013

Remark:

1. All test items were verified and recorded according to the standards and without any deviation during the test.
2. This EUT has also been tested and complied with the requirements of FCC Part 15, Subpart B, recorded in a separate test report.



2 Test Configuration of Equipment Under Test

The EUT has been associated with peripherals and configuration operated in a manner tended to maximize its emission characteristics in a typical application. Frequency range investigated: conducted emission (150 kHz to 30 MHz) and radiated emission (9 kHz to the 10th harmonic of the highest fundamental frequency or to 40 GHz, whichever is lower). For radiated measurement, pre-scanned in three orthogonal panels, X, Y, Z. The worst cases (X plane) were recorded in this report.

2.1 Carrier Frequency Channel

Frequency Band	Channel	Freq. (MHz)	Channel	Freq. (MHz)
5180-5240 MHz Band 1 (U-NII-1)	36	5180	44	5220
	38*	5190	46*	5230
	40	5200	48	5240
	-	-	-	-

Frequency Band	Channel	Freq. (MHz)	Channel	Freq. (MHz)
5260-5320 MHz Band 2 (U-NII-2A)	52	5260	60	5300
	54*	5270	62*	5310
	56	5280	64	5320
	-	-	-	-

Frequency Band	Channel	Freq. (MHz)	Channel	Freq. (MHz)
5500-5700 MHz Band 3 (U-NII-2C)	100	5500	112	5560
	102*	5510	116	5580
	104	5520	132	5660
	-	-	134*	5670
	108	5540	136	5680
	110*	5550	140	5700

Note: The above Frequency and Channel in "*" were 802.11n HT40.



2.2 Test Mode

Final test mode of conducted test items and radiated spurious emissions are considering the modulation and worse data rates as below table.

Modulation	Data Rate
802.11a	6 Mbps
802.11n HT20	MCS0
802.11n HT40	MCS0

AC Conducted Emission	<p>Mode 1 : GSM850 Idle + Bluetooth Link + WLAN Link (5G) + USB Cable (Charging from Adapter 1) + Earphone 1 + Battery</p> <p>Mode 2 : GSM850 Idle + Bluetooth Link + WLAN Link (5G) + USB Cable (Charging from Adapter 2) + Earphone 2 + Battery</p> <p>Mode 3 : GSM850 Idle + Bluetooth Link + WLAN Link (5G) + USB Cable (Charging from Adapter 3) + Earphone 1 + Battery</p>
<p>Remark:</p> <ol style="list-style-type: none"> For Radiated TCs, the tests were performed with Adapter 1, Adapter 2, Adapter 3, Earphone 1, Earphone 2, Battery and USB Cable. The worst case of conducted emission is mode 1; only the test data of it was reported. 	



Ch. #		Band I : 5180-5240 MHz	Band II : 5260-5320 MHz	Band III : 5500-5700MHz
		802.11a	802.11a	802.11a
L	Low	36	52	100
M	Middle	44	60	116
H	High	48	64	140

Ch. #		Band I : 5180-5240 MHz	Band II : 5260-5320 MHz	Band III : 5500-5700MHz
		802.11n HT20	802.11n HT20	802.11n HT20
L	Low	36	52	100
M	Middle	44	60	116
H	High	48	64	140

Ch. #		Band I : 5180-5240 MHz	Band II : 5260-5320 MHz	Band III : 5500-5700MHz
		802.11n HT40	802.11n HT40	802.11n HT40
L	Low	38	54	102
M	Middle	-	-	110
H	High	46	62	134

2.3 Connection Diagram of Test System

<WLAN Tx Mode>

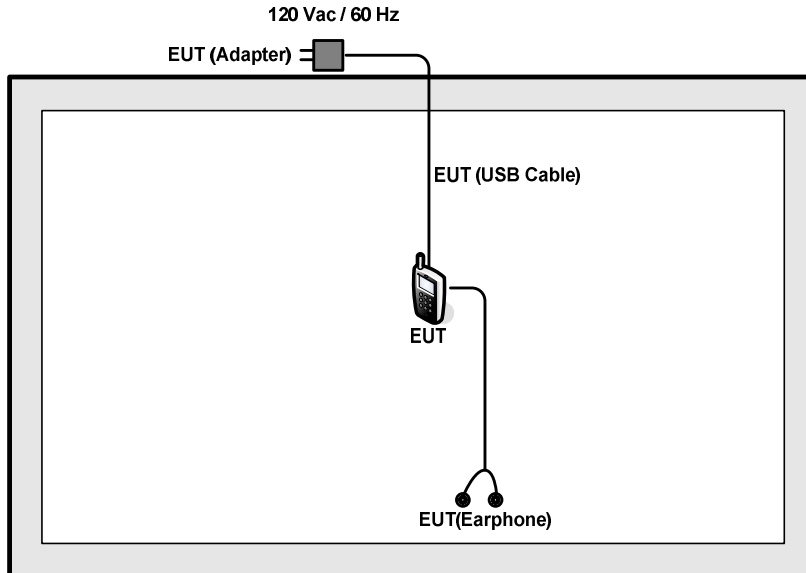

<AC Conducted Emission Mode>

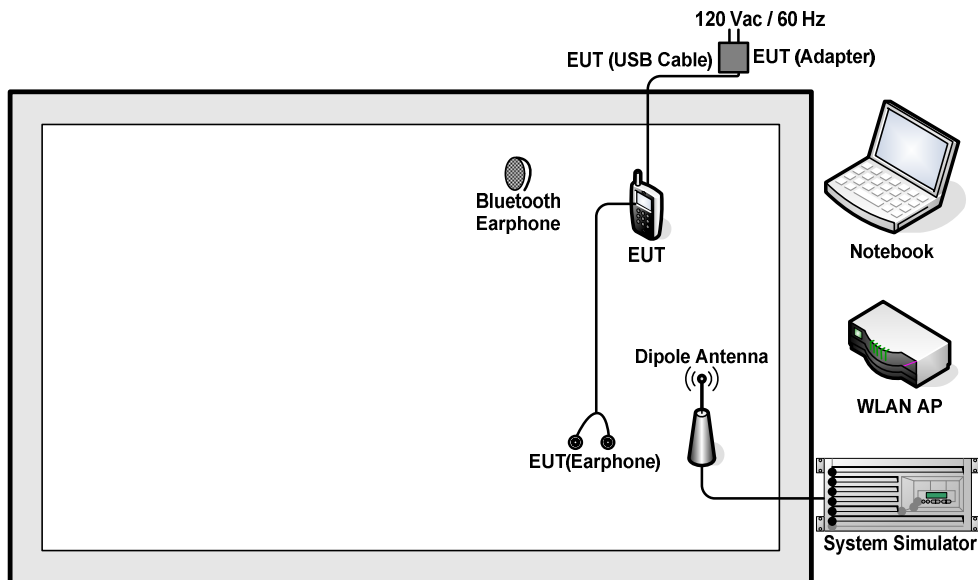



2.4 Support Unit used in test configuration and system

Item	Equipment	Trade Name	Model Name	FCC ID	Data Cable	Power Cord
1.	System Simulator	Anritsu	MT8820C	N/A	N/A	Unshielded, 1.8 m
2.	WLAN AP	Cisco	Air-AP1262N-A-K9	LDK102073	N/A	Unshielded, 1.8m
3.	WLAN AP	D-LINK	DIR-855	KA2DIR855A2	N/A	Unshielded, 1.8 m
4.	Notebook	Lenovo	Edge E335	PPD-AR5B95	N/A	AC I/P: Unshielded, 1.8 m DC O/P: Shielded, 1.8 m
5.	Notebook	Lenovo	G480	PRC4	N/A	AC I/P: Unshielded, 1.8 m DC O/P: Shielded, 1.8 m
6.	Bluetooth Earphone	Lenovo	LBH308	N/A	N/A	N/A

2.5 EUT Operation Test Setup

For WLAN RF test items, an engineering test program was provided and enabled to make EUT continuously transmit/receive.

For AC power line conducted emissions, the EUT was set to connect with the Notebook under large package sizes transmission.

2.6 Measurement Results Explanation Example

For all conducted test items:

The offset level is set in the spectrum analyzer to compensate the RF cable loss between EUT conducted output port and spectrum analyzer. With the offset compensation, the spectrum analyzer reading level is exactly the EUT RF output level.

Example:

The spectrum analyzer offset is derived from RF cable loss.

Offset = RF cable loss.

Following shows an offset computation example with cable loss 6.6 dB.

$$\text{Offset (dB)} = \text{RF cable loss(dB)}.$$

$$= 6.6 \text{ (dB)}$$

3 Test Result

3.1 26dB & 99% Occupied Bandwidth Measurement

3.1.1 Description of 26dB & 99% Occupied Bandwidth

This section is for reporting purpose only.

There is no restriction limits for bandwidth.

3.1.2 Measuring Instruments

The measuring equipment is listed in the section 4 of this test report.

3.1.3 Test Procedures

1. The testing follows FCC KDB 789033 D02 General UNII Test Procedures New Rules v01r04.
Section C) Emission bandwidth
2. Set RBW = approximately 1% of the emission bandwidth.
3. Set the VBW > RBW.
4. Detector = Peak.
5. Trace mode = max hold
6. Measure the maximum width of the emission that is 26 dB down from the peak of the emission.
Compare this with the RBW setting of the analyzer. Readjust RBW and repeat measurement as needed until the RBW/EBW ratio is approximately 1%.
7. For 99% Bandwidth Measurement, the spectrum analyzer's resolution bandwidth (RBW) is set 1MHz and set the Video bandwidth (VBW) $\geq 3 * RBW$.
8. Measure and record the results in the test report.

3.1.4 Test Setup

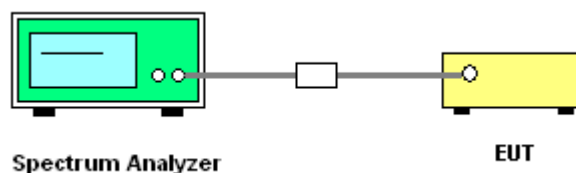



3.1.5 Test Result of 26dB & 99% Occupied Bandwidth Plots

Please refer to Appendix A.

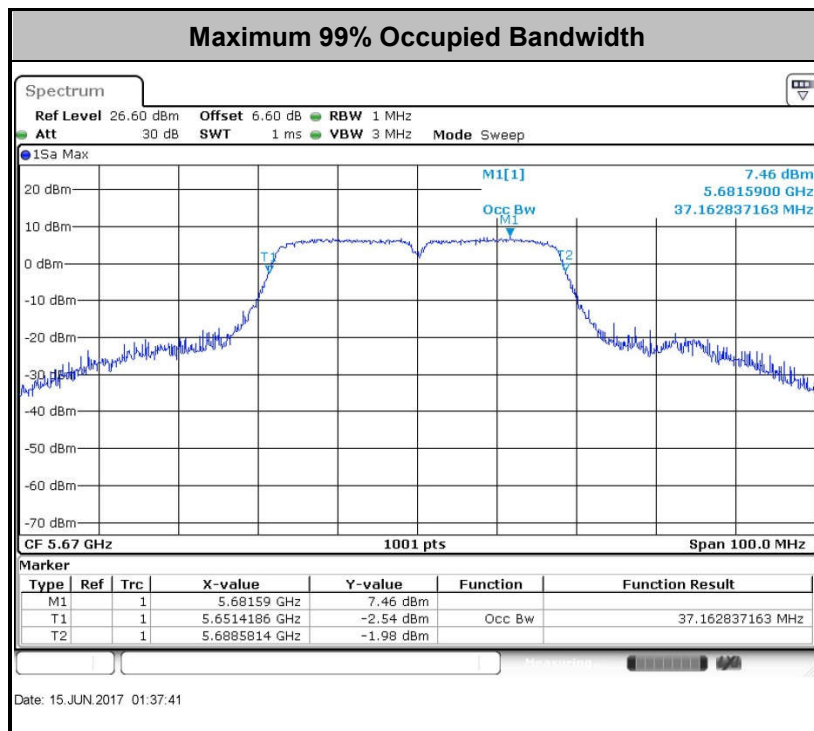
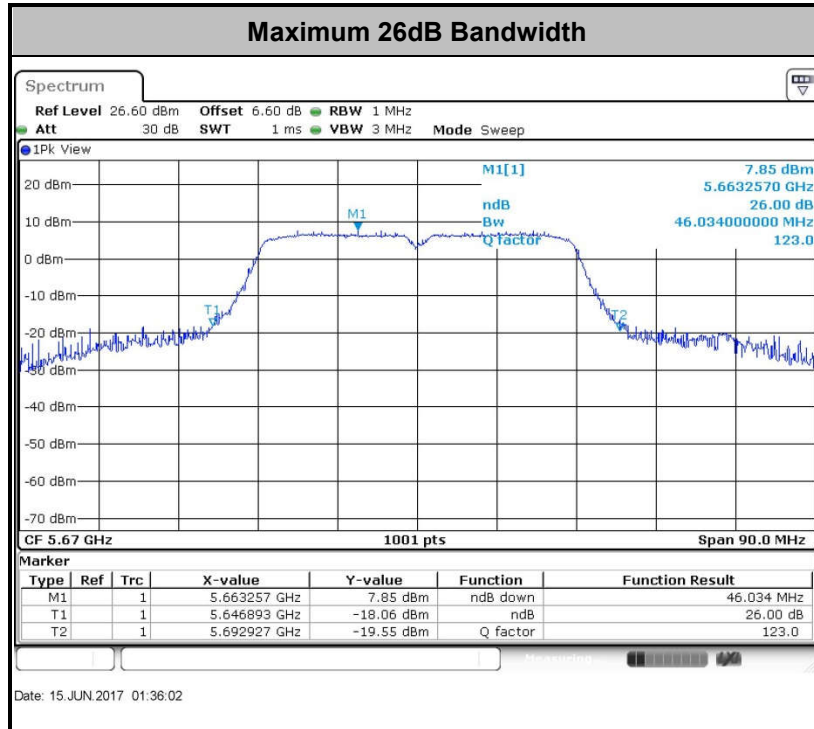

Note : The occupied channel bandwidth is maintained within the band of operation for all of the modulations.



3.2 Maximum Conducted Output Power Measurement

3.2.1 Limit of Maximum Conducted Output Power

<FCC 14-30 CFR 15.407>

For mobile and portable client devices in the 5.15–5.25 GHz band, the maximum conducted output power over the frequency band of operation shall not exceed 250 mW.

For the 5.25–5.725 GHz bands, the maximum conducted output power over the frequency bands of operation shall not exceed the lesser of 250 mW or $11 \text{ dBm} + 10 \log B$, where B is the 26 dB emission bandwidth in megahertz.

If transmitting antennas of directional gain greater than 6 dBi are used, the peak output power shall be reduced by the amount in dB that the directional gain of the antenna exceeds 6 dBi.

Note that U-NII-2 band, devices with a maximum e.i.r.p. greater than 500 mW shall implement TPC in order to have the capability to operate at least 6 dB below the maximum permitted e.i.r.p. of 1 W.

3.2.2 Measuring Instruments

The measuring equipment is listed in the section 4 of this test report.

3.2.3 Test Procedures

The testing follows Method PM of FCC KDB 789033 D02 General UNII Test Procedures New Rules v01r04.

Method PM (Measurement using an RF average power meter):

1. Measurement is performed using a wideband RF power meter.
2. The EUT is configured to transmit continuously with a consistent duty cycle at its maximum power control level.
3. Measure the average power of the transmitter, and the average power is corrected with duty factor, $10 \log(1/x)$, where x is the duty cycle.

3.2.4 Test Setup

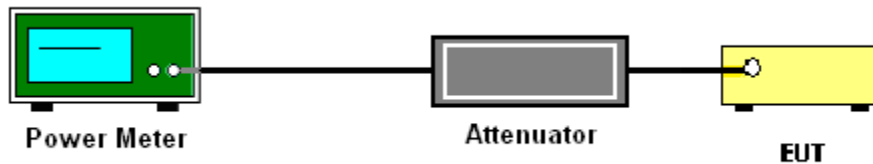

3.2.5 Test Result of Maximum Conducted Output Power

Please refer to Appendix A.



3.3 Power Spectral Density Measurement

3.3.1 Limit of Power Spectral Density

<FCC 14-30 CFR 15.407>

For mobile and portable client devices in the 5.15–5.25 GHz band, the maximum power spectral density shall not exceed 11dBm in any 1 megahertz band.

For the 5.25–5.725 GHz bands, the maximum power spectral density shall not exceed 11 dBm in any 1 megahertz band.

If transmitting antennas of directional gain greater than 6 dBi are used, the peak output power shall be reduced by the amount in dB that the directional gain of the antenna exceeds 6 dBi.

3.3.2 Measuring Instruments

The measuring equipment is listed in the section 4 of this test report.

3.3.3 Test Procedures

The testing follows FCC KDB 789033 D02 General UNII Test Procedures New Rules v01r04.
Section F) Maximum power spectral density.

Method SA-2

(trace averaging across on and off times of the EUT transmissions, followed by duty cycle correction).

1. The testing follows Method SA-2 of FCC KDB 789033 D02 General UNII Test Procedures New Rules v01r04.
 - Measure the duty cycle.
 - Set span to encompass the entire emission bandwidth (EBW) of the signal.
 - Set RBW = 1 MHz.
 - Set VBW \geq 3 MHz.
 - Number of points in sweep \geq 2 Span / RBW.
 - Sweep time = auto.
 - Detector = RMS
 - Trace average at least 100 traces in power averaging mode.
 - Add $10 \log(1/x)$, where x is the duty cycle, to the measured power in order to compute the average power during the actual transmission times. For example, add $10 \log(1/0.25) = 6$ dB if the duty cycle is 25 percent.
2. The RF output of EUT was connected to the spectrum analyzer by a low loss cable.
3. Each plot has already offset with cable loss, and attenuator loss. Measure the PPSD and record it.

3.3.4 Test Setup

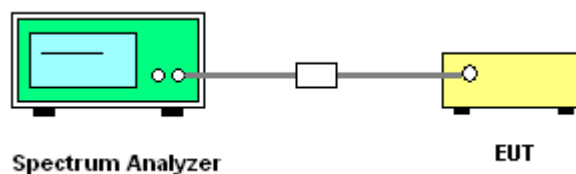



3.3.5 Test Result of Power Spectral Density

Please refer to Appendix A.

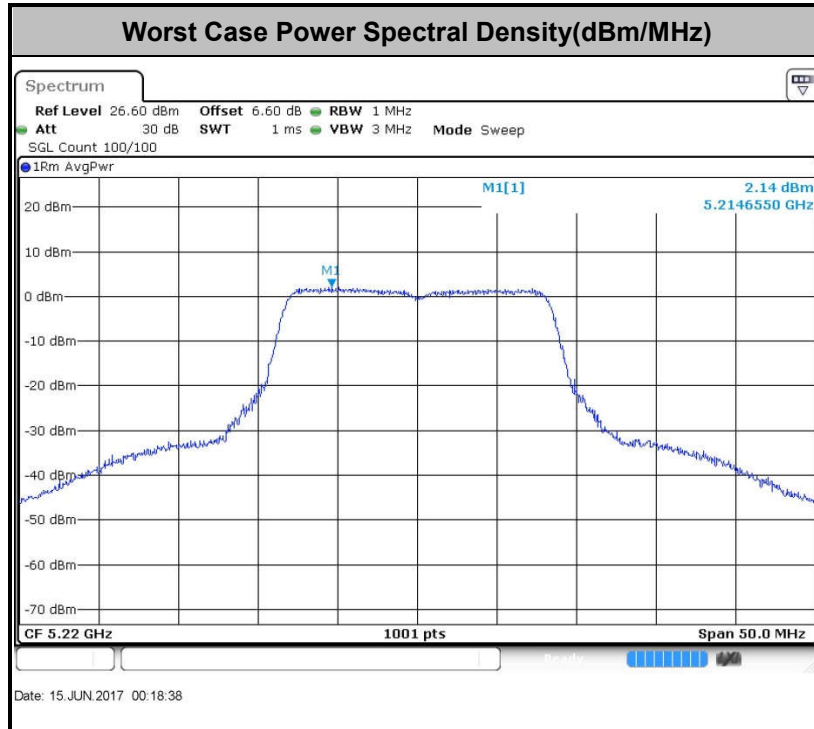

Note: Average Power Density (dB) = Measured value+ Duty Factor



3.4 Unwanted Radiated Emission Measurement

This section as specified in FCC Part 15.407(b) is to measure unwanted emissions through radiated measurement for band edge spurious emissions and out of band emissions measurement. The unwanted emissions shall comply with 15.407(b)(1) to (6), and restricted bands per FCC Part15.205.

3.4.1 Limit of Unwanted Emissions

- (1) For transmitters operating in the 5150-5250 MHz band: all emissions outside of the 5150-5350 MHz band shall not exceed an EIRP of -27dBm/MHz.

For transmitters operating in the 5250-5350 MHz band: all emissions outside of the 5150-5350 MHz band shall not exceed an EIRP of -27 dBm/MHz. Devices operating in the 5250-5350 MHz band that generate emissions in the 5150-5250 MHz band must meet all applicable technical requirements for operation in the 5150-5250 MHz band (including indoor use) or alternatively meet an out-of-band emission EIRP limit of -27 dBm/MHz in the 5150-5250 MHz band.

For transmitters operating in the 5470-5725MHz band: all emissions outside of the 5470-5725MHz band shall not exceed an EIRP of -27 dBm/MHz.

- (2) Unwanted spurious emissions fallen in restricted bands shall comply with the general field strength limits as below table

Frequency (MHz)	Field Strength (microvolts/meter)	Measurement Distance (meters)
0.009 – 0.490	2400/F(kHz)	300
0.490 – 1.705	24000/F(kHz)	30
1.705 – 30.0	30	30
30 – 88	100	3
88 – 216	150	3
216 - 960	200	3
Above 960	500	3

Note: The following formula is used to convert the EIRP to field strength.

$$E = \frac{1000000\sqrt{30P}}{3} \mu\text{V/m, where P is the eirp (Watts)}$$



EIRP (dBm)	Field Strength at 3m (dBμV/m)
- 27	68.3

(3) KDB789033 D01 v01r04 G)2)c)

- (i) Section 15.407(b)(1) to (b)(3) specify the unwanted emission limits for the U-NII-1 and U-NII-2 bands. As specified, emissions above 1000 MHz that are outside of the restricted bands are subject to a peak emission limit of -27 dBm/MHz.³
- (ii) Section 15.407(b)(4) specifies the unwanted emission limit for the U-NII-3 band. A band emissions mask is specified in Section 15.407(b)(4)(i). The emission limits are in terms of a Peak detector. An alternative to the band emissions mask is specified in Section 15.407(b)(4)(ii). The alternative limits are based on the highest antenna gain specified in the filing. There are also marketing and importation restrictions for the devices using the alternative limit.⁴

Note 3: An out-of-band emission that complies with both the average and peak limits of Section 15.209 is not required to satisfy the -27 dBm/MHz peak emission limit.

Note 4: Only devices with antenna gains of 10 dBi or less may be approved using the emission limits specified in Section 15.247(d) till March 2, 2018; all other devices operating in this band must use the mask specified in Section 15.407(b)(4)(i).



3.4.2 Measuring Instruments

The measuring equipment is listed in the section 4 of this test report.

3.4.3 Test Procedures

1. The testing follows FCC KDB 789033 D02 General UNII Test Procedures New Rules v01r04. Section G) Unwanted emissions measurement.

(1) Procedure for Unwanted Emissions Measurements Below 1000MHz

- RBW = 120 kHz
- VBW = 300 kHz
- Detector = Peak
- Trace mode = max hold

(2) Procedure for Peak Unwanted Emissions Measurements Above 1000 MHz

- RBW = 1 MHz
- VBW \geq 3 MHz
- Detector = Peak
- Sweep time = auto
- Trace mode = max hold

(3) Procedures for Average Unwanted Emissions Measurements Above 1000MHz

- RBW = 1 MHz
- VBW = 10 Hz, when duty cycle is no less than 98 percent.
- VBW \geq 1/T, when duty cycle is less than 98 percent where T is the minimum transmission duration over which the transmitter is on and is transmitting at its maximum power control level for the tested mode of operation.

2. The EUT was placed on a turntable with 0.8 meter for frequency below 1GHz and 1.5 meter for frequency above 1GHz respectively above ground.
3. The EUT was set 3 meters from the interference receiving antenna which was mounted on the top of a variable height antenna tower.
4. The antenna is a broadband antenna and its height is adjusted between one meter and four meters above ground to find the maximum value of the field strength for both horizontal polarization and vertical polarization of the antenna.
5. For each suspected emission, the EUT was arranged to its worst case and then adjust the antenna tower (from 1 m to 4 m) and turntable (from 0 degree to 360 degrees) to find the maximum reading.
6. For testing below 1GHz, if the emission level of the EUT in peak mode was 3 dB lower than the limit specified, then peak values of EUT will be reported, otherwise, the emissions will be repeated one by one using the CISPR quasi-peak method and reported.
7. For testing above 1GHz, the emission level of the EUT in peak mode was 20dB lower than average limit (that means the emission level in average mode also complies with the limit in average mode), then peak values of EUT will be reported, otherwise, the emissions will be measured in average mode again and reported.

3.4.4 Test Setup

For radiated emissions below 30MHz

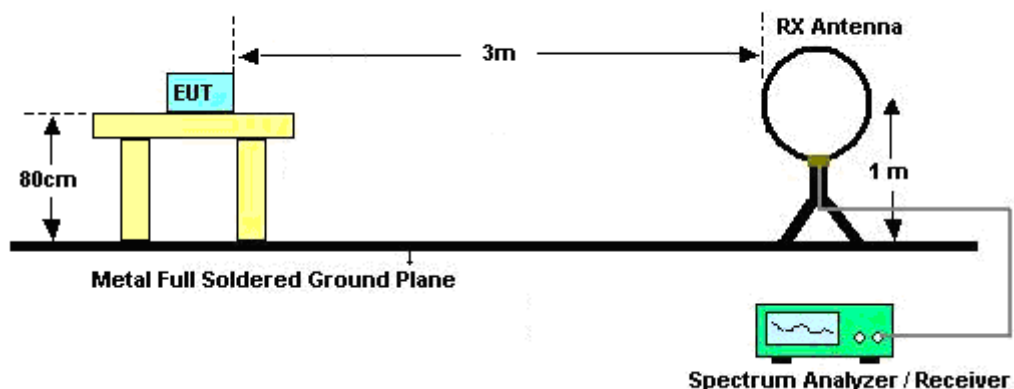

For radiated emissions from 30MHz to 1GHz

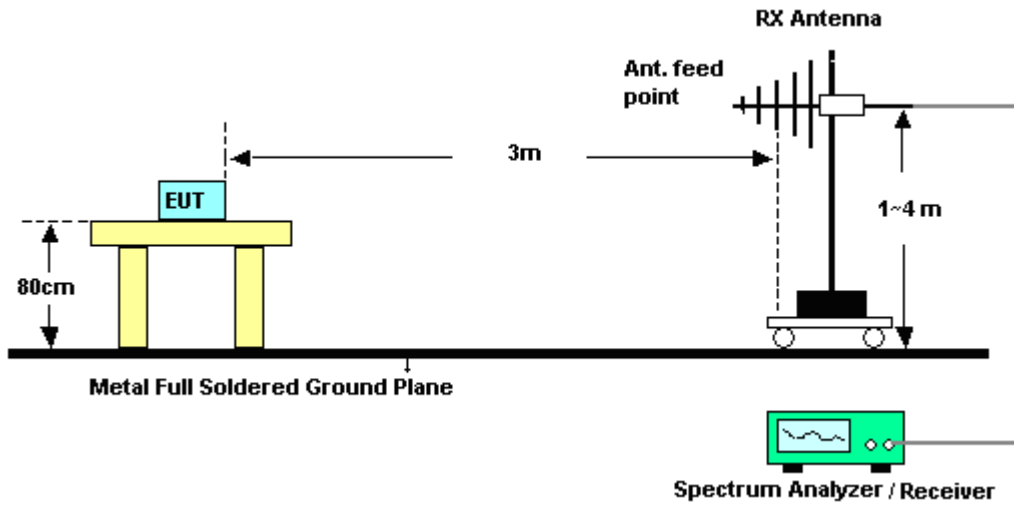

For radiated emissions above 1GHz

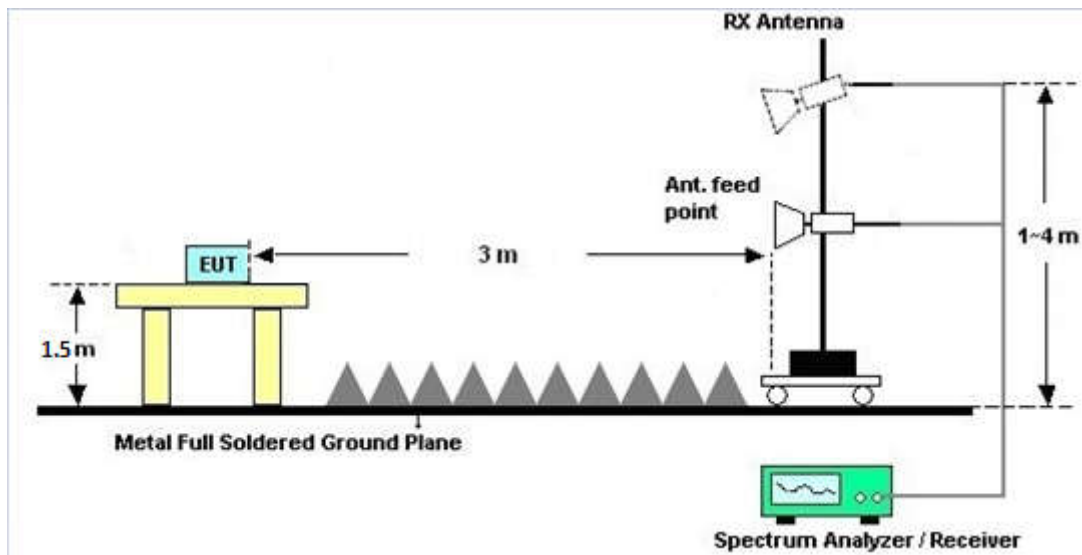



3.4.5 Test Results of Radiated Spurious Emissions (9 kHz ~ 30 MHz)

The low frequency, which started from 9 kHz to 30MHz, was pre-scanned and the result which was 20dB lower than the limit line was not reported.

3.4.6 Test Result of Radiated Spurious at Band Edges

Please refer to Appendix B.

3.4.7 Duty Cycle

Please refer to Appendix C.

3.4.8 Test Result of Radiated Spurious Emissions (30MHz ~ 10th Harmonic)

Please refer to Appendix B.



3.5 AC Conducted Emission Measurement

3.5.1 Limit of AC Conducted Emission

For equipment that is designed to be connected to the public utility (AC) power line, the radio frequency voltage that is conducted back onto the AC power line on any frequency or frequencies within the band 150 kHz to 30 MHz shall not exceed the limits in the following table.

Frequency of emission (MHz)	Conducted limit (dB μ V)	
	Quasi-peak	Average
0.15-0.5	66 to 56*	56 to 46*
0.5-5	56	46
5-30	60	50

*Decreases with the logarithm of the frequency.

3.5.2 Measuring Instruments

The measuring equipment is listed in the section 4 of this test report.

3.5.3 Test Procedures

1. The EUT was placed 0.4 meter from the conducting wall of the shielding room was kept at least 80 centimeters from any other grounded conducting surface.
2. Connect EUT to the power mains through a line impedance stabilization network (LISN).
3. All the support units are connecting to the other LISN.
4. The LISN provides 50 ohm coupling impedance for the measuring instrument.
5. The FCC states that a 50 ohm, 50 microhenry LISN should be used.
6. Both sides of AC line were checked for maximum conducted interference.
7. The frequency range from 150 kHz to 30 MHz was searched.
8. Set the test-receiver system to Peak Detect Function and specified bandwidth with Maximum Hold Mode.

3.5.4 Test Setup

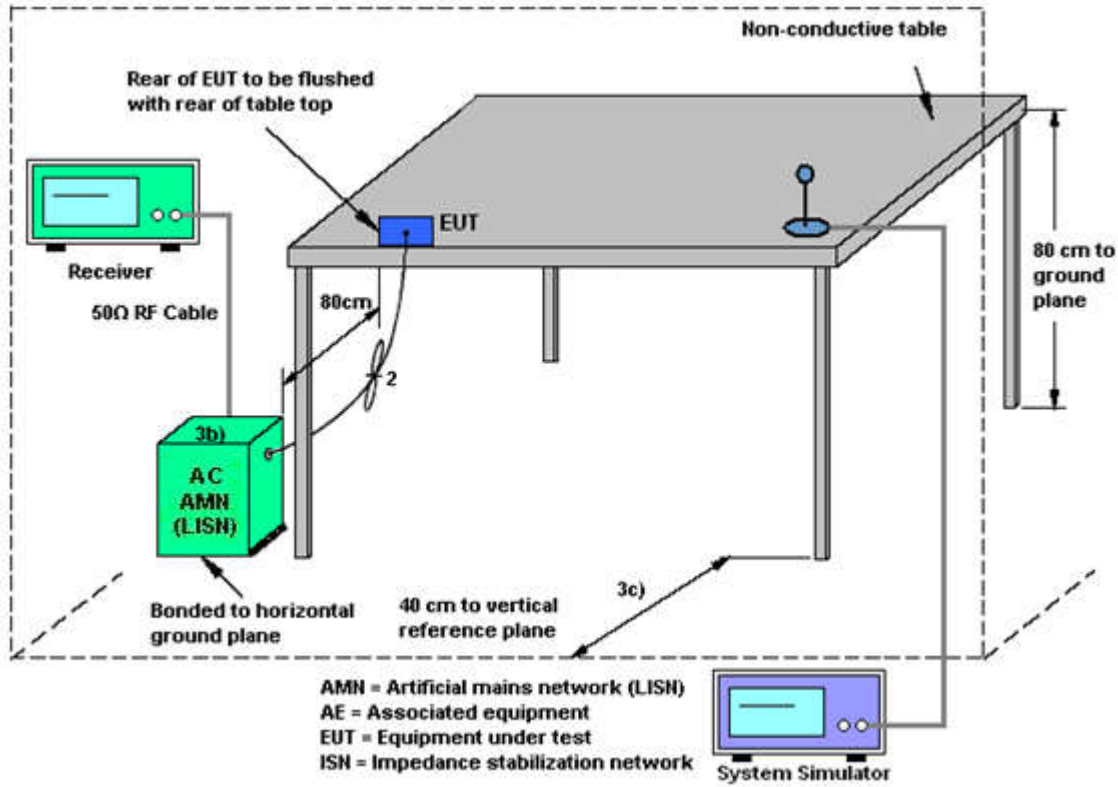



3.5.5 Test Result of AC Conducted Emission

Test Mode :	Mode 1	Temperature :	22~24°C
Test Engineer :	Amos Zhang	Relative Humidity :	42~46%
Test Voltage :	120Vac / 60Hz	Phase :	Line
Function Type :	GSM850 Idle + Bluetooth Link + WLAN Link (5G) + USB Cable (Charging from Adapter 1) + Earphone 1 + Battery		

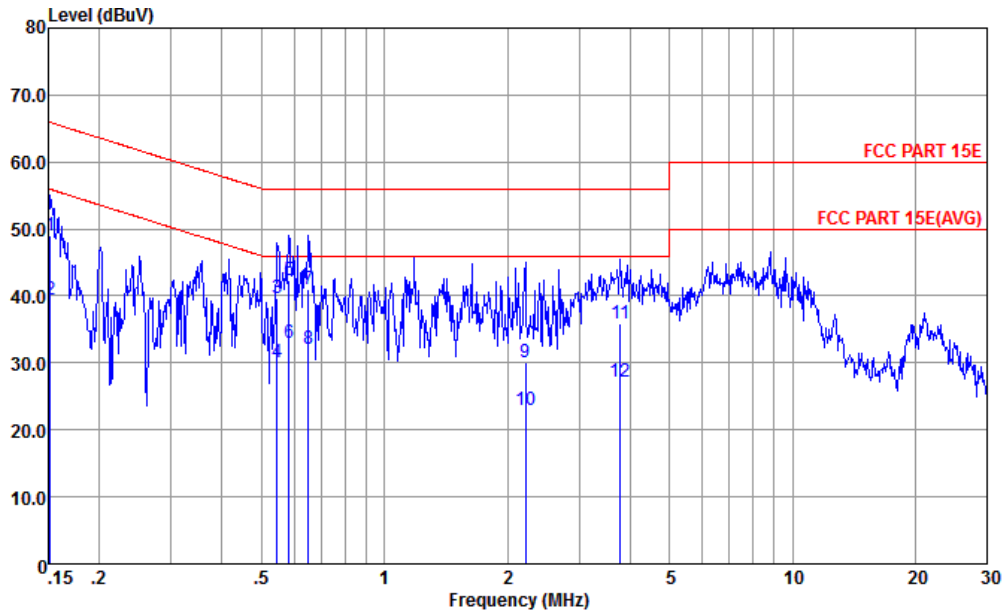

Site : CO01-KS
 Condition : FCC PART 15E LISN-L-161017-060103 LINE
 mode : Mode 1
 : 355666080014854 #9

	Freq	Level	Over Limit	Limit Line	Read Level	LISN Factor	Cable Loss	Remark
	MHz	dBuV	dB	dBuV	dBuV	dB	dB	
1	0.152	49.13	-16.78	65.91	38.20	0.54	10.39	QP
2	0.152	39.43	-16.48	55.91	28.50	0.54	10.39	Average
3	0.546	39.65	-16.35	56.00	29.20	0.26	10.19	QP
4	0.546	30.05	-15.95	46.00	19.60	0.26	10.19	Average
5	0.582	42.24	-13.76	56.00	31.80	0.26	10.18	QP
6 *	0.582	33.04	-12.96	46.00	22.60	0.26	10.18	Average
7	0.651	41.03	-14.97	56.00	30.60	0.25	10.18	QP
8	0.651	32.03	-13.97	46.00	21.60	0.25	10.18	Average
9	2.213	30.01	-25.99	56.00	19.60	0.21	10.20	QP
10	2.213	22.91	-23.09	46.00	12.50	0.21	10.20	Average
11	3.779	35.95	-20.05	56.00	25.50	0.21	10.24	QP
12	3.779	27.25	-18.75	46.00	16.80	0.21	10.24	Average



Test Mode :	Mode 1	Temperature :	22~24°C
Test Engineer :	Amos Zhang	Relative Humidity :	42~46%
Test Voltage :	120Vac / 60Hz	Phase :	Neutral
Function Type :	GSM850 Idle + Bluetooth Link + WLAN Link (5G) + USB Cable (Charging from Adapter 1) + Earphone 1 + Battery		

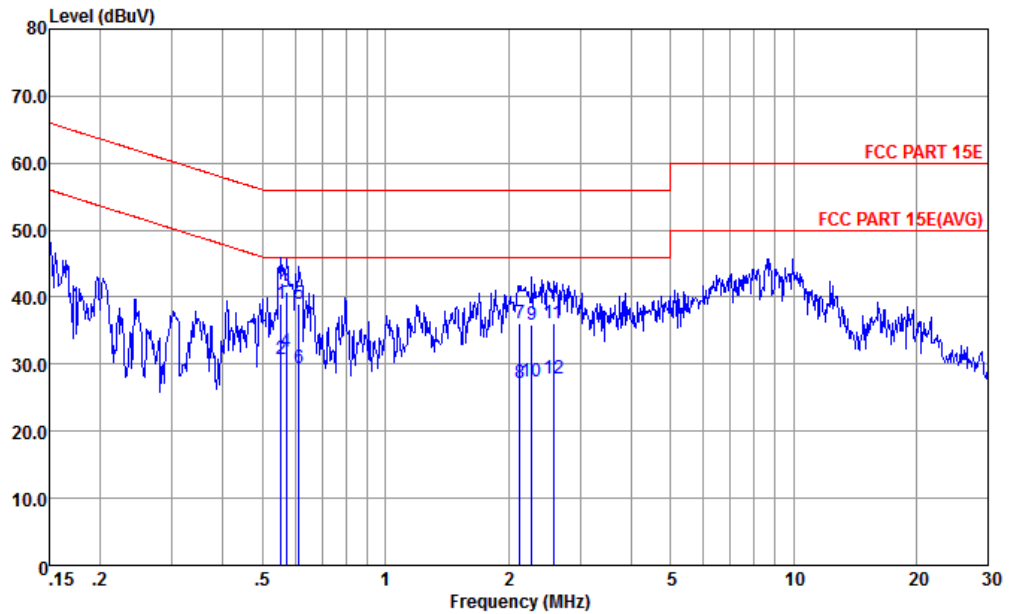

Site : CO01-KS
 Condition : FCC PART 15E LISN-N-161017-060103 NEUTRAL

mode : Mode 1
 : 355666080014854 #9

	Freq	Level	Over Limit	Limit Line	Read Level	LISN Factor	Cable Loss	Remark
	MHz	dBuV	dB	dBuV	dBuV	dB	dB	
1	0.555	39.06	-16.94	56.00	28.50	0.38	10.18	QP
2	0.555	30.76	-15.24	46.00	20.20	0.38	10.18	Average
3	0.570	40.76	-15.24	56.00	30.20	0.38	10.18	QP
4 *	0.570	31.86	-14.14	46.00	21.30	0.38	10.18	Average
5	0.614	39.06	-16.94	56.00	28.50	0.38	10.18	QP
6	0.614	29.36	-16.64	46.00	18.80	0.38	10.18	Average
7	2.133	36.10	-19.90	56.00	25.50	0.41	10.19	QP
8	2.133	27.20	-18.80	46.00	16.60	0.41	10.19	Average
9	2.285	35.80	-20.20	56.00	25.19	0.41	10.20	QP
10	2.285	27.30	-18.70	46.00	16.69	0.41	10.20	Average
11	2.581	36.21	-19.79	56.00	25.60	0.40	10.21	QP
12	2.581	27.91	-18.09	46.00	17.30	0.40	10.21	Average

3.6 Frequency Stability Measurement

3.6.1 Limit of Frequency Stability

Manufacturers of U-NII devices are responsible for ensuring frequency stability such that an emission is maintained within the band of operation under all conditions of normal operation as specified in the user's manual.

3.6.2 Measuring Instruments

The measuring equipment is listed in the section 4 of this test report.

3.6.3 Test Procedures

1. To ensure emission at the band edge is maintained within the authorized band, those values shall be measured by radiation emissions at upper and lower frequency points, and finally compensated by frequency deviation as procedures below.
2. The EUT was operated at the maximum output power, and connected to the spectrum analyzer, which is set to maximum hold function and peak detector. The peak value of the power envelope was measured and noted. The upper and lower frequency points were respectively measured relatively 10dB lower than the measured peak value.
3. The frequency deviation was calculated by adding the upper frequency point and the lower frequency point divided by two. Those detailed values of frequency deviation are provided in table below.

3.6.4 Test Setup

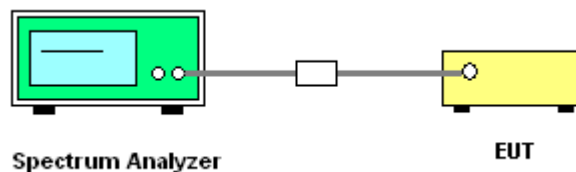

3.6.5 Test Result of Frequency Stability

Please refer to Appendix A.



3.7 Automatically Discontinue Transmission

3.7.1 Limit of Automatically Discontinue Transmission

The device shall automatically discontinue transmission in case of either absence of information to transmit or operational failure. These provisions are not intended to preclude the transmission of control or signaling information or the use of repetitive codes used by certain digital technologies to complete frame or burst intervals. Applicants shall include in their application for equipment authorization to describe how this requirement is met.

3.7.2 Measuring Instruments

The measuring equipment is listed in the section 4 of this test report.

3.7.3 Test Result of Automatically Discontinue Transmission

While the EUT is not transmitting any information, the EUT can automatically discontinue transmission and become standby mode for power saving. The EUT can detect the controlling signal of ACK message transmitting from remote device and verify whether it shall resend or discontinue transmission.



3.8 Antenna Requirements

3.8.1 Standard Applicable

If transmitting antenna directional gain is greater than 6 dBi, both the peak transmit power and the peak power spectral density shall be reduced by the amount in dB that the directional gain of the antenna exceeds 6 dBi.

3.8.2 Antenna Anti-Replacement Construction

An embedded-in antenna design is used.

3.8.3 Antenna Gain

The antenna gain is less than 6 dBi. Therefore, it is not necessary to reduce maximum peak output power limit.



4 List of Measuring Equipments

Instrument	Manufacturer	Model No.	Serial No.	Characteristics	Calibration Date	Test Date	Due Date	Remark
Spectrum Analyzer	R&S	FSV40	101040	10Hz~40GHz	Aug. 09, 2016	Jun. 12, 2017~ Jun. 15, 2017	Aug. 08, 2017	Conducted (TH01-KS)
Pulse Power Sensor	Anritsu	MA2411B	0917070	300MHz~40GHz	Jan. 19, 2017	Jun. 12, 2017~ Jun. 15, 2017	Jan. 18, 2018	Conducted (TH01-KS)
Power Meter	Anritsu	ML2495A	1005002	50MHz Bandwidth	Jan. 19, 2017	Jun. 12, 2017~ Jun. 15, 2017	Jan. 18, 2018	Conducted (TH01-KS)
Thermal Chamber	Ten Billion	TTC-B3S	TBN-960502	-40~+150°C	Oct. 13, 2016	Jun. 12, 2017~ Jun. 15, 2017	Oct. 12, 2017	Conducted (TH01-KS)
EMI Test Receiver	Keysight	N9038A	MY56400004	3Hz~8.5GHz;Max x 30dBm	Oct. 22, 2016	Jun. 06, 2017~ Jun. 12, 2017	Oct. 21, 2017	Radiation (03CH03-KS)
EXA Spectrum Analyzer	Keysight	N9010A	MY55150244	10Hz-44GHz	Apr. 18, 2017	Jun. 06, 2017~ Jun. 12, 2017	Apr. 17, 2018	Radiation (03CH03-KS)
Loop Antenna	R&S	HFH2-Z2	100321	9kHz~30MHz	Nov. 23, 2016	Jun. 06, 2017~ Jun. 12, 2017	Nov. 22, 2017	Radiation (03CH03-KS)
Bilog Antenna	TeseQ	CBL6112D	35406	25MHz-2GHz	Apr. 22, 2017	Jun. 06, 2017~ Jun. 12, 2017	Apr. 21, 2018	Radiation (03CH03-KS)
Horn Antenna	Schwarzbeck	BBHA9120D	9120D-1356	1GHz~18GHz	Apr. 22, 2017	Jun. 06, 2017~ Jun. 12, 2017	Apr. 21, 2018	Radiation (03CH03-KS)
SHF-EHF Horn	com-power	AH-840	101070	18GHz ~40GHz	Oct. 19, 2016	Jun. 06, 2017~ Jun. 12, 2017	Oct. 18, 2017	Radiation (03CH03-KS)
Amplifier	com-power	PA-103A	161069	1MHz ~1000MHz / 32 dB	Apr. 18, 2017	Jun. 06, 2017~ Jun. 12, 2017	Apr. 17, 2018	Radiation (03CH03-KS)
Amplifier	MITEQ	TTA1840-35-H G	1887435	18GHz~40GHz	Oct. 13, 2016	Jun. 06, 2017~ Jun. 12, 2017	Oct. 12, 2017	Radiation (03CH03-KS)
high gain Amplifier	MITEQ	AMF-7D-0010 1800-30-10P	2025788	1Ghz-18Ghz	Apr. 18, 2017	Jun. 06, 2017~ Jun. 12, 2017	Apr. 17, 2018	Radiation (03CH03-KS)
Amplifier	Agilent	8449B	3008A02370	1GHz~26.5GHz	Oct. 13, 2016	Jun. 06, 2017~ Jun. 12, 2017	Oct. 12, 2017	Radiation (03CH03-KS)
AC Power Source	Chroma	61601	F104090004	N/A	NCR	Jun. 06, 2017~ Jun. 12, 2017	NCR	Radiation (03CH03-KS)
Turn Table	ChamPro	EM 1000-T	060762-T	0~360 degree	NCR	Jun. 06, 2017~ Jun. 12, 2017	NCR	Radiation (03CH03-KS)
EMI Receiver	R&S	ESC17	100768	9kHz~7GHz;	Apr. 20, 2017	Jun. 22, 2017	Apr. 19, 2018	Conduction (CO01-KS)
AC LISN	MessTec	AN3016	060103	9kHz~30MHz	Oct. 13, 2016	Jun. 22, 2017	Oct. 12, 2017	Conduction (CO01-KS)
AC LISN (for auxiliary equipment)	MessTec	AN3016	060105	9kHz~30MHz	Oct. 13, 2016	Jun. 22, 2017	Oct. 12, 2017	Conduction (CO01-KS)
AC Power Source	Chroma	61602	ABP0000008 11	AC 0V~300V, 45Hz~1000Hz	Oct. 13, 2016	Jun. 22, 2017	Oct. 12, 2017	Conduction (CO01-KS)

NCR: No Calibration Required



5 Uncertainty of Evaluation

Uncertainty of Conducted Emission Measurement (150kHz ~ 30MHz)

Measuring Uncertainty for a Level of Confidence of 95% ($U = 2Uc(y)$)	2.3dB
---	-------

Uncertainty of Radiated Emission Measurement (30 MHz ~ 1000 MHz)

Measuring Uncertainty for a Level of Confidence of 95% ($U = 2Uc(y)$)	4.6dB
---	-------

Uncertainty of Radiated Emission Measurement (1GHz ~ 18GHz)

Measuring Uncertainty for a Level of Confidence of 95% ($U = 2Uc(y)$)	4.5dB
---	-------

Uncertainty of Radiated Emission Measurement (18GHz ~ 40GHz)

Measuring Uncertainty for a Level of Confidence of 95% ($U = 2Uc(y)$)	4.7dB
---	-------



Appendix A. Conducted Test Results

Test Engineer:	Silent Hai	Temperature:	21~25	°C
Test Date:	2017/6/12~2017/6/15	Relative Humidity:	51~55	%

TEST RESULTS DATA
26dB and 99% OBW

Band I										
Mod.	Data Rate	NTX	CH.	Freq. (MHz)	99% Bandwidth (MHz)	26 dB Bandwidth (MHz)	IC 99% Bandwidth Power Limit (dBm)	IC 99% Bandwidth EIRP Limit (dBm)		
11a	6Mbps	1	36	5180	18.53	23.28	-	22.68		
11a	6Mbps	1	44	5220	18.63	23.83	-	22.70		
11a	6Mbps	1	48	5240	18.63	23.43	-	22.70		
HT20	MCS0	1	36	5180	19.18	23.63	-	22.83		
HT20	MCS0	1	44	5220	19.53	24.33	-	22.91		
HT20	MCS0	1	48	5240	19.48	23.98	-	22.90		
HT40	MCS0	1	38	5190	36.96	45.23	-	23.01		
HT40	MCS0	1	46	5230	37.06	44.78	-	23.01		

TEST RESULTS DATA
Average Power Table

FCC Band I										
Mod.	Data Rate	NTX	CH.	Freq. (MHz)	Duty Factor (dB)	Average Conducted Power (dBm)	FCC Conducted Power Limit (dBm)	DG (dBi)		Pass/Fail
11a	6Mbps	1	36	5180	0.58	13.21	24.00	-3.20		Pass
11a	6Mbps	1	44	5220	0.58	13.26	24.00	-3.20		Pass
11a	6Mbps	1	48	5240	0.58	13.59	24.00	-3.20		Pass
HT20	MCS0	1	36	5180	0.66	13.18	24.00	-3.20		Pass
HT20	MCS0	1	44	5220	0.66	13.42	24.00	-3.20		Pass
HT20	MCS0	1	48	5240	0.66	13.69	24.00	-3.20		Pass
HT40	MCS0	1	38	5190	0.66	13.83	24.00	-3.20		Pass
HT40	MCS0	1	46	5230	0.66	14.12	24.00	-3.20		Pass

TEST RESULTS DATA
Power Spectral Density

FCC Band I										
Mod.	Data Rate	N _{TX}	CH.	Freq. (MHz)	Duty Factor (dB)	Average Power Density (dBm/MHz)	Average PSD Limit (dBm/MHz)	DG (dBi)	-	Pass/Fail
11a	6Mbps	1	36	5180	0.58	2.03	11.00	-3.20		Pass
11a	6Mbps	1	44	5220	0.58	2.72	11.00	-3.20		Pass
11a	6Mbps	1	48	5240	0.58	2.20	11.00	-3.20		Pass
HT20	MCS0	1	36	5180	0.66	1.88	11.00	-3.20		Pass
HT20	MCS0	1	44	5220	0.66	2.29	11.00	-3.20		Pass
HT20	MCS0	1	48	5240	0.66	1.95	11.00	-3.20		Pass
HT40	MCS0	1	38	5190	0.66	-0.32	11.00	-3.20		Pass
HT40	MCS0	1	46	5230	0.66	-0.64	11.00	-3.20		Pass

TEST RESULTS DATA
26dB and 99% OBW

Band II										
Mod.	Data Rate	NTX	CH.	Freq. (MHz)	99% Bandwidth (MHz)	26 dB Bandwidth (MHz)	IC 99% Bandwidth Power Limit (dBm)	IC 99% Bandwidth EIRP Limit (dBm)	FCC 26dB Bandwidth Power Limit (dBm)	Note
11a	6M bps	1	52	5260	18.73	23.68	23.73	29.73	23.98	
11a	6M bps	1	60	5300	18.78	23.58	23.74	29.74	23.98	
11a	6M bps	1	64	5320	18.68	23.83	23.71	29.71	23.98	
HT20	MCS 0	1	52	5260	19.38	23.73	23.87	29.87	23.98	
HT20	MCS 0	1	60	5300	19.38	23.83	23.87	29.87	23.98	
HT20	MCS 0	1	64	5320	19.43	23.68	23.88	29.88	23.98	
HT40	MCS 0	1	54	5270	36.86	45.50	23.98	30.00	23.98	
HT40	MCS 0	1	62	5310	36.86	45.58	23.98	30.00	23.98	

TEST RESULTS DATA
Average Power Table

FCC Band II										
Mod.	Data Rate	NTX	CH.	Freq. (MHz)	Duty Factor (dB)	Average Conducted Power (dBm)	FCC Conducted Power Limit (dBm)	DG (dBi)	EIRP Power Limit (dBm)	Pass/Fail
11a	6M bps	1	52	5260	0.58	13.46	23.98	-4.10	26.99	Pass
11a	6M bps	1	60	5300	0.58	12.80	23.98	-4.10	26.99	Pass
11a	6M bps	1	64	5320	0.58	13.00	23.98	-4.10	26.99	Pass
HT20	MCS 0	1	52	5260	0.66	13.30	23.98	-4.10	26.99	Pass
HT20	MCS 0	1	60	5300	0.66	12.85	23.98	-4.10	26.99	Pass
HT20	MCS 0	1	64	5320	0.66	12.98	23.98	-4.10	26.99	Pass
HT40	MCS 0	1	54	5270	0.66	14.13	23.98	-4.10	26.99	Pass
HT40	MCS 0	1	62	5310	0.66	13.51	23.98	-4.10	26.99	Pass

TEST RESULTS DATA
Power Spectral Density

Band II										
Mod.	Data Rate	NTX	CH.	Freq. (MHz)	Duty Factor (dB)	Average Power Density (dBm/MHz)	Average PSD Limit (dBm/MHz)	DG (dBi)		Pass/Fail
11a	6M bps	1	52	5260	0.58	2.37	11.00	-4.10		Pass
11a	6M bps	1	60	5300	0.58	1.76	11.00	-4.10		Pass
11a	6M bps	1	64	5320	0.58	1.97	11.00	-4.10		Pass
HT20	MCS 0	1	52	5260	0.66	2.26	11.00	-4.10		Pass
HT20	MCS 0	1	60	5300	0.66	1.92	11.00	-4.10		Pass
HT20	MCS 0	1	64	5320	0.66	2.05	11.00	-4.10		Pass
HT40	MCS 0	1	54	5270	0.66	-0.32	11.00	-4.10		Pass
HT40	MCS 0	1	62	5310	0.66	-0.82	11.00	-4.10		Pass

TEST RESULTS DATA
26dB and 99% OBW

Band III										
Mod.	Data Rate	NTX	CH.	Freq. (MHz)	99% Bandwidth (MHz)	26 dB Bandwidth (MHz)	IC 99% Bandwidth Power Limit (dBm)	IC 99% Bandwidth EIRP Limit (dBm)	FCC 26dB Bandwidth Power Limit (dBm)	Note
11a	6M bps	1	100	5500	18.78	23.48	23.74	29.74	23.98	
11a	6M bps	1	116	5580	18.68	23.93	23.71	29.71	23.98	
11a	6M bps	1	140	5700	18.83	23.68	23.75	29.75	23.98	
HT20	MCS 0	1	100	5500	19.53	23.98	23.91	29.91	23.98	
HT20	MCS 0	1	116	5580	19.58	23.98	23.92	29.92	23.98	
HT20	MCS 0	1	140	5700	19.63	23.98	23.93	29.93	23.98	
HT40	MCS 0	1	102	5510	36.96	45.50	23.98	30.00	23.98	
HT40	MCS 0	1	110	5550	37.06	45.67	23.98	30.00	23.98	
HT40	MCS 0	1	134	5670	37.16	46.03	23.98	30.00	23.98	

TEST RESULTS DATA
Average Power Table

FCC Band III										
Mod.	Data Rate	NTX	CH.	Freq. (MHz)	Duty Factor (dB)	Average Conducted Power (dBm)	FCC Conducted Power Limit (dBm)	DG (dBi)	EIRP Power Limit (dBm)	Pass/Fail
11a	6M bps	1	100	5500	0.58	13.31	23.98	-4.50	26.99	Pass
11a	6M bps	1	116	5580	0.58	12.99	23.98	-4.50	26.99	Pass
11a	6M bps	1	140	5700	0.58	13.15	23.98	-4.50	26.99	Pass
HT20	MCS 0	1	100	5500	0.66	13.32	23.98	-4.50	26.99	Pass
HT20	MCS 0	1	116	5580	0.66	13.12	23.98	-4.50	26.99	Pass
HT20	MCS 0	1	140	5700	0.66	13.28	23.98	-4.50	26.99	Pass
HT40	MCS 0	1	102	5510	0.66	13.78	23.98	-4.50	26.99	Pass
HT40	MCS 0	1	110	5550	0.66	13.89	23.98	-4.50	26.99	Pass
HT40	MCS 0	1	134	5670	0.66	13.67	23.98	-4.50	26.99	Pass

TEST RESULTS DATA
Power Spectral Density

Band III										
Mod.	Data Rate	NTX	CH.	Freq. (MHz)	Duty Factor (dB)	Average Power Density (dBm/MHz)	Average PSD Limit (dBm/MHz)	DG (dBi)		Pass/Fail
11a	6M bps	1	100	5500	0.58	2.27	11.00	-4.50		Pass
11a	6M bps	1	116	5580	0.58	1.86	11.00	-4.50		Pass
11a	6M bps	1	140	5700	0.58	1.55	11.00	-4.50		Pass
HT20	MCS 0	1	100	5500	0.66	1.68	11.00	-4.50		Pass
HT20	MCS 0	1	116	5580	0.66	1.87	11.00	-4.50		Pass
HT20	MCS 0	1	140	5700	0.66	1.67	11.00	-4.50		Pass
HT40	MCS 0	1	102	5510	0.66	-0.77	11.00	-4.50		Pass
HT40	MCS 0	1	110	5550	0.66	-1.01	11.00	-4.50		Pass
HT40	MCS 0	1	134	5670	0.66	-0.49	11.00	-4.50		Pass

TEST RESULTS DATA
Frequency Stability

Band I										
Mod.	Data Rate	NTX	CH.	Freq. (MHz)	Center Frequency (MHz)	Frequency Deviation (MHz)	Frequency Stability (ppm)	Temperature (°C)	Voltage (V)	Note
11a	6Mbps	1	36	5180	5180.000	0.000	0.00	50	3.8	
11a	6Mbps	1	36	5180	5180.050	0.050	9.65	-30	3.8	
11a	6Mbps	1	36	5180	5180.025	0.025	4.83	25	4.2	
11a	6Mbps	1	36	5180	5180.000	0.000	0.00	25	3.6	
11a	6Mbps	1	36	5180	5180.025	0.025	4.83	25	3.8	

Band II										
Mod.	Data Rate	NTX	CH.	Freq. (MHz)	Center Frequency (MHz)	Frequency Deviation (MHz)	Frequency Stability (ppm)	Temperature (°C)	Voltage (V)	Note
11a	6Mbps	1	64	5320	5320.000	0.000	0.00	50	3.8	
11a	6Mbps	1	64	5320	5320.025	0.025	4.70	-30	3.8	
11a	6Mbps	1	64	5320	5320.025	0.025	4.70	25	4.2	
11a	6Mbps	1	64	5320	5320.025	0.025	4.70	25	3.6	
11a	6Mbps	1	64	5320	5320.025	0.025	4.70	25	3.8	

Band III										
Mod.	Data Rate	NTX	CH.	Freq. (MHz)	Center Frequency (MHz)	Frequency Deviation (MHz)	Frequency Stability (ppm)	Temperature (°C)	Voltage (V)	Note
11a	6Mbps	1	100	5500	5500.000	0.000	0.00	50	3.8	
11a	6Mbps	1	100	5500	5500.050	0.050	9.09	-30	3.8	
11a	6Mbps	1	100	5500	5500.025	0.025	4.55	25	4.2	
11a	6Mbps	1	100	5500	5500.050	0.050	9.09	25	3.6	
11a	6Mbps	1	100	5500	5500.050	0.050	9.09	25	3.8	



Appendix B. Radiated Spurious Emission

Band 1 - 5150~5250MHz WIFI 802.11a (Band Edge @ 3m)

WIFI Ant.	Note	Frequency	Level	Over Limit	Limit Line	Read Level	Antenna Factor	Cable Loss	Preamp Factor	Ant Pos	Table Pos	Peak Avg.	Pol.
1		(MHz)	(dBμV/m)	(dB)	(dBμV/m)	(dBμV)	(dB/m)	(dB)	(dB)	(cm)	(deg)	(P/A)	(H/V)
802.11a CH 36 5180MHz		5147.04	52.17	-21.83	74	49.61	31.17	7.92	36.53	100	123	P	H
		5150	40.87	-13.13	54	38.31	31.17	7.92	36.53	100	123	A	H
	*	5176	98.58	-	-	96.02	31.14	7.94	36.52	100	123	P	H
	*	5176	91.05	-	-	88.49	31.14	7.94	36.52	100	123	A	H
		5149.92	49.75	-24.25	74	47.19	31.17	7.92	36.53	347	111	P	V
		5150	39.56	-14.44	54	37	31.17	7.92	36.53	347	111	A	V
	*	5174	96.53	-	-	93.97	31.14	7.94	36.52	347	111	P	V
	*	5174	89.36	-	-	86.8	31.14	7.94	36.52	347	111	A	V
802.11a CH 44 5220MHz		5135.52	46.36	-27.64	74	43.8	31.19	7.91	36.54	100	121	P	H
		5100.96	36.93	-17.07	54	34.37	31.22	7.9	36.56	100	121	A	H
	*	5216	99.48	-	-	96.88	31.11	7.99	36.5	100	121	P	H
	*	5216	92.19	-	-	89.59	31.11	7.99	36.5	100	121	A	H
		5353.02	44.25	-29.75	74	41.36	30.98	8.34	36.43	100	121	P	H
		5397.3	35.59	-18.41	54	32.59	30.93	8.48	36.41	100	121	A	H
		5139.04	45.95	-28.05	74	43.39	31.19	7.91	36.54	323	112	P	V
		5102.08	36.81	-17.19	54	34.25	31.22	7.9	36.56	323	112	A	V
	*	5224	96.52	-	-	93.92	31.11	7.99	36.5	323	112	P	V
	*	5224	89.29	-	-	86.69	31.11	7.99	36.5	323	112	A	V
		5359.32	45.3	-28.7	74	42.41	30.98	8.34	36.43	323	112	P	V
	5390.82	35.59	-18.41	54	32.64	30.94	8.43	36.42	323	112	A	V	



802.11a CH 48 5240MHz	*	5246	99.29	-	-	96.62	31.07	8.08	36.48	100	118	P	H
	*	5246	92.09	-	-	89.42	31.07	8.08	36.48	100	118	A	H
		5352.66	44.14	-29.86	74	41.25	30.98	8.34	36.43	100	118	P	H
		5364.54	35.7	-18.3	54	32.77	30.96	8.39	36.42	100	118	A	H
	*	5236	97.04	-	-	94.4	31.09	8.04	36.49	321	110	P	V
	*	5236	89.73	-	-	87.09	31.09	8.04	36.49	321	110	A	V
		5365.98	44.58	-29.42	74	41.65	30.96	8.39	36.42	321	110	P	V
		5397.3	35.73	-18.27	54	32.73	30.93	8.48	36.41	321	110	A	V
Remark	1. No other spurious found. 2. All results are PASS against Peak and Average limit line.												



Band 1 5150~5250MHz

WIFI 802.11a (Harmonic @ 3m)

WIFI Ant. 1	Note	Frequency (MHz)	Level (dBμV/m)	Over Limit (dB)	Limit Line (dBμV/m)	Read Level (dBμV)	Antenna Factor (dB/m)	Cable Loss (dB)	Preamp Factor (dB)	Ant Pos (cm)	Table Pos (deg)	Peak Avg. (P/A)	Pol. (H/V)
802.11a		10360	42.46	-31.54	74	59.37	37.4	11.84	66.15	100	360	P	H
CH 36		10360	41.41	-32.59	74	58.32	37.4	11.84	66.15	100	360	P	V
5180MHz													
802.11a		10440	42.24	-31.76	74	58.98	37.47	11.89	66.1	100	360	P	H
CH 44		10440	41.55	-32.45	74	58.29	37.47	11.89	66.1	100	360	P	V
5220MHz													
802.11a		10480	41.31	-32.69	74	57.94	37.52	11.92	66.07	100	360	P	H
CH 48		10480	42.96	-31.04	74	59.59	37.52	11.92	66.07	100	360	P	V
5240MHz													
Remark	1. No other spurious found. 2. All results are PASS against Peak and Average limit line.												



Band 1 5150~5250MHz
WIFI 802.11n HT20 (Band Edge @ 3m)

WIFI Ant. 1	Note	Frequency (MHz)	Level (dBμV/m)	Over Limit (dB)	Limit Line (dBμV/m)	Read Level (dBμV)	Antenna Factor (dB/m)	Cable Loss (dB)	Preamp Factor (dB)	Ant Pos (cm)	Table Pos (deg)	Peak Avg. (P/A)	Pol. (H/V)
802.11n HT20 CH 36 5180MHz		5148.96	51.36	-22.64	74	48.8	31.17	7.92	36.53	100	123	P	H
		5149.99	40.6	-13.4	54	38.04	31.17	7.92	36.53	100	123	A	H
	*	5186	96.12	-	-	93.56	31.14	7.94	36.52	100	123	P	H
	*	5186	89.01	-	-	86.45	31.14	7.94	36.52	100	123	A	H
		5150	49.07	-24.93	74	46.51	31.17	7.92	36.53	322	119	P	V
		5149.76	39.19	-14.81	54	36.63	31.17	7.92	36.53	322	119	A	V
	*	5186	94.52	-	-	91.96	31.14	7.94	36.52	322	119	P	V
	5186	86.92	-	-	84.36	31.14	7.94	36.52	322	119	A	V	
802.11n HT20 CH 44 5220MHz		5132.64	46.18	-27.82	74	43.62	31.19	7.91	36.54	100	119	P	H
		5105.6	36.8	-17.2	54	34.24	31.2	7.91	36.55	100	119	A	H
	*	5226	97.58	-	-	94.94	31.09	8.04	36.49	100	119	P	H
	*	5226	90.22	-	-	87.58	31.09	8.04	36.49	100	119	A	H
		5381.82	44.4	-29.6	74	41.45	30.94	8.43	36.42	100	119	P	H
		5389.38	35.69	-18.31	54	32.74	30.94	8.43	36.42	100	119	A	H
		5127.2	46.46	-27.54	74	43.9	31.19	7.91	36.54	316	113	P	V
		5117.12	36.76	-17.24	54	34.2	31.2	7.91	36.55	316	113	A	V
	*	5226	94.44	-	-	91.8	31.09	8.04	36.49	316	113	P	V
	*	5226	87.42	-	-	84.78	31.09	8.04	36.49	316	113	A	V
		5362.74	44.29	-29.71	74	41.36	30.96	8.39	36.42	316	113	P	V
	5392.98	35.42	-18.58	54	32.47	30.94	8.43	36.42	316	113	A	V	



802.11n HT20 CH 48 5240MHz	*	5234	98.08	-	-	95.44	31.09	8.04	36.49	100	125	P	H
	*	5234	90.85	-	-	88.21	31.09	8.04	36.49	100	125	A	H
		5376.96	44.96	-29.04	74	42.03	30.96	8.39	36.42	100	125	P	H
		5398.92	35.6	-18.4	54	32.6	30.93	8.48	36.41	100	125	A	H
	*	5248	94.87	-	-	92.2	31.07	8.08	36.48	336	108	P	V
	*	5248	87.39	-	-	84.72	31.07	8.08	36.48	336	108	A	V
		5354.82	44.96	-29.04	74	42.07	30.98	8.34	36.43	336	108	P	V
		5383.08	35.59	-18.41	54	32.64	30.94	8.43	36.42	336	108	A	V
Remark	<ol style="list-style-type: none"> No other spurious found. All results are PASS against Peak and Average limit line. 												



Band 1 5150~5250MHz
WIFI 802.11n HT20 (Harmonic @ 3m)

Table with 14 columns: WIFI Ant. 1, Note, Frequency (MHz), Level (dBµV/m), Over Limit (dB), Limit Line (dBµV/m), Read Level (dBµV), Antenna Factor (dB/m), Cable Loss (dB), Preamp Factor (dB), Ant Pos (cm), Table Pos (deg), Peak Avg. (P/A), Pol. (H/V). Rows include data for 10360, 10440, and 10480 MHz channels.



Band 1 5150~5250MHz
WIFI 802.11n HT40 (Band Edge @ 3m)

WIFI Ant. 1	Note	Frequency (MHz)	Level (dBμV/m)	Over Limit (dB)	Limit Line (dBμV/m)	Read Level (dBμV)	Antenna Factor (dB/m)	Cable Loss (dB)	Preamp Factor (dB)	Ant Pos (cm)	Table Pos (deg)	Peak Avg. (P/A)	Pol. (H/V)
802.11n HT40 CH 38 5190MHz		5146.56	60.46	-13.54	74	57.9	31.17	7.92	36.53	100	115	P	H
	!	5150	50.23	-3.77	54	47.67	31.17	7.92	36.53	100	115	A	H
	*	5180	94.47	-	-	91.91	31.14	7.94	36.52	100	115	P	H
	*	5180	87.14	-	-	84.58	31.14	7.94	36.52	100	115	A	H
		5361.12	44.41	-29.59	74	41.48	30.96	8.39	36.42	100	115	P	H
		5397.12	35.44	-18.56	54	32.44	30.93	8.48	36.41	100	115	A	H
		5146.88	59.98	-14.02	74	57.42	31.17	7.92	36.53	325	118	P	V
		5149.6	47.16	-6.84	54	44.6	31.17	7.92	36.53	325	118	A	V
	*	5202	92.27	-	-	89.71	31.12	7.95	36.51	325	118	P	V
	*	5202	84.67	-	-	82.11	31.12	7.95	36.51	325	118	A	V
		5382.9	45.42	-28.58	74	42.47	30.94	8.43	36.42	325	118	P	V
		5383.44	35.39	-18.61	54	32.44	30.94	8.43	36.42	325	118	A	V
802.11n HT40 CH 46 5230MHz		5125.12	46.6	-27.4	74	44.04	31.19	7.91	36.54	100	117	P	H
		5127.52	37.63	-16.37	54	35.07	31.19	7.91	36.54	100	117	A	H
	*	5216	94.67	-	-	92.07	31.11	7.99	36.5	100	117	P	H
	*	5216	87.85	-	-	85.25	31.11	7.99	36.5	100	117	A	H
		5353.92	44.66	-29.34	74	41.77	30.98	8.34	36.43	100	117	P	H
		5363.82	35.39	-18.61	54	32.46	30.96	8.39	36.42	100	117	A	H
		5124.96	47.05	-26.95	74	44.49	31.19	7.91	36.54	336	117	P	V
		5127.68	36.96	-17.04	54	34.4	31.19	7.91	36.54	336	117	A	V
	*	5242	91.15	-	-	88.48	31.07	8.08	36.48	336	117	P	V
	*	5242	83.95	-	-	81.28	31.07	8.08	36.48	336	117	A	V
	5362.02	43.97	-30.03	74	41.04	30.96	8.39	36.42	336	117	P	V	
	5365.08	35.44	-18.56	54	32.51	30.96	8.39	36.42	336	117	A	V	
Remark	1. No other spurious found. 2. All results are PASS against Peak and Average limit line.												



Band 1 5150~5250MHz
WIFI 802.11n HT40 (Harmonic @ 3m)

Table with 14 columns: WIFI Ant. 1, Note, Frequency (MHz), Level (dBµV/m), Over Limit (dB), Limit Line (dBµV/m), Read Level (dBµV), Antenna Factor (dB/m), Cable Loss (dB), Preamp Factor (dB), Ant Pos (cm), Table Pos (deg), Peak Avg. (P/A), Pol. (H/V). Rows include data for 10380 MHz and 10460 MHz channels.



Band 1 5150~5250MHz

Band 2 - 5250~5350MHz

WIFI 802.11a (Band Edge @ 3m)

WIFI Ant.	Note	Frequency	Level	Over Limit	Limit Line	Read Level	Antenna Factor	Cable Loss	Preamp Factor	Ant Pos	Table Pos	Peak Avg.	Pol.
1		(MHz)	(dBμV/m)	(dB)	(dBμV/m)	(dBμV)	(dB/m)	(dB)	(dB)	(cm)	(deg)	(P/A)	(H/V)
802.11a CH 52 5260MHz		5112.8	45.92	-28.08	74	43.36	31.2	7.91	36.55	100	124	P	H
		5104.48	36.79	-17.21	54	34.23	31.22	7.9	36.56	100	124	A	H
	*	5266	98.8	-	-	96.09	31.06	8.12	36.47	100	124	P	H
	*	5266	91.35	-	-	88.64	31.06	8.12	36.47	100	124	A	H
		5120	46.4	-27.6	74	43.84	31.2	7.91	36.55	356	111	P	V
		5107.36	36.73	-17.27	54	34.17	31.2	7.91	36.55	356	111	A	V
	*	5262	96.97	-	-	94.26	31.06	8.12	36.47	356	111	P	V
	*	5262	89.57	-	-	86.86	31.06	8.12	36.47	356	111	A	V
802.11a CH 60 5300MHz		5118.24	47.47	-26.53	74	44.91	31.2	7.91	36.55	100	125	P	H
		5104	36.88	-17.12	54	34.32	31.22	7.9	36.56	100	125	A	H
	*	5296	98.86	-	-	96.09	31.02	8.21	36.46	100	125	P	H
	*	5296	91.11	-	-	88.34	31.02	8.21	36.46	100	125	A	H
		5352.9	47.15	-26.85	74	44.26	30.98	8.34	36.43	100	125	P	H
		5352.2	39.52	-14.48	54	36.63	30.98	8.34	36.43	100	125	A	H
		5100	45.94	-28.06	74	43.38	31.22	7.9	36.56	333	101	P	V
		5107.04	36.72	-17.28	54	34.16	31.2	7.91	36.55	333	101	A	V
	*	5304	96.67	-	-	93.9	31.02	8.21	36.46	333	101	P	V
	*	5304	88.86	-	-	86.09	31.02	8.21	36.46	333	101	A	V
		5351.9	45.74	-28.26	74	42.85	30.98	8.34	36.43	333	101	P	V
		5352.4	38.16	-15.84	54	35.27	30.98	8.34	36.43	333	101	A	V



802.11a CH 64 5320MHz	*	5326	97.74	-	-	94.92	31.01	8.26	36.45	100	122	P	H
	*	5326	90.55	-	-	87.73	31.01	8.26	36.45	100	122	A	H
		5352.9	50.35	-23.65	74	47.46	30.98	8.34	36.43	100	122	P	H
		5350.1	40.29	-13.71	54	37.4	30.98	8.34	36.43	100	122	A	H
	*	5324	96.35	-	-	93.53	31.01	8.26	36.45	324	111	P	V
	*	5324	89.06	-	-	86.24	31.01	8.26	36.45	324	111	A	V
		5351.6	49.42	-24.58	74	46.53	30.98	8.34	36.43	324	111	P	V
		5350.3	39.84	-14.16	54	36.95	30.98	8.34	36.43	324	111	A	V
Remark	<ol style="list-style-type: none"> No other spurious found. All results are PASS against Peak and Average limit line. 												



Band 2 5250~5350MHz

WIFI 802.11a (Harmonic @ 3m)

WIFI Ant. 1	Note	Frequency (MHz)	Level (dBμV/m)	Over Limit (dB)	Limit Line (dBμV/m)	Read Level (dBμV)	Antenna Factor (dB/m)	Cable Loss (dB)	Preamp Factor (dB)	Ant Pos (cm)	Table Pos (deg)	Peak Avg. (P/A)	Pol. (H/V)
802.11a		10520	41.2	-32.8	74	57.74	37.56	11.94	66.04	100	360	P	H
CH 52 5260MHz		10520	41.79	-32.21	74	58.33	37.56	11.94	66.04	100	360	P	V
802.11a		10600	41.35	-32.65	74	57.68	37.65	12	65.98	100	360	P	H
CH 60 5300MHz		10600	40.34	-33.66	74	56.67	37.65	12	65.98	100	360	P	V
802.11a		10640	40.24	-33.76	74	56.5	37.68	12.02	65.96	100	360	P	H
CH 64 5320MHz		10640	40.17	-33.83	74	56.43	37.68	12.02	65.96	100	360	P	V
Remark	1. No other spurious found. 2. All results are PASS against Peak and Average limit line.												



Band 2 5250~5350MHz
WIFI 802.11n HT20 (Band Edge @ 3m)

Table with 14 columns: WIFI Ant. 1, Note, Frequency (MHz), Level (dBµV/m), Over Limit (dB), Limit Line (dBµV/m), Read Level (dBµV), Antenna Factor (dB/m), Cable Loss (dB), Preamp Factor (dB), Ant Pos (cm), Table Pos (deg), Peak Avg. (P/A), Pol. (H/V). Rows include data for 802.11n HT20 CH 52 (5260MHz) and 802.11n HT20 CH 60 (5300MHz).



802.11n HT20 CH 64 5320MHz	*	5316	96.68	-	-	93.86	31.01	8.26	36.45	100	114	P	H
	*	5316	89.27	-	-	86.45	31.01	8.26	36.45	100	114	A	H
		5350.4	51.32	-22.68	74	48.43	30.98	8.34	36.43	100	114	P	H
		5350.01	40.27	-13.73	54	37.38	30.98	8.34	36.43	100	114	A	H
	*	5314	94.44	-	-	91.62	31.01	8.26	36.45	330	111	P	V
	*	5314	87.22	-	-	84.4	31.01	8.26	36.45	330	111	A	V
		5351.3	51.32	-22.68	74	48.43	30.98	8.34	36.43	330	111	P	V
		5350.2	39.39	-14.61	54	36.5	30.98	8.34	36.43	330	111	A	V
Remark	<ol style="list-style-type: none"> No other spurious found. All results are PASS against Peak and Average limit line. 												



Band 2 5250~5350MHz
WIFI 802.11n HT20 (Harmonic @ 3m)

Table with 14 columns: WIFI Ant. 1, Note, Frequency (MHz), Level (dBµV/m), Over Limit (dB), Limit Line (dBµV/m), Read Level (dBµV), Antenna Factor (dB/m), Cable Loss (dB), Preamp Factor (dB), Ant Pos (cm), Table Pos (deg), Peak Avg. (P/A), Pol. (H/V). Rows include data for 802.11n HT20 CH 52 (5260MHz), 802.11n HT20 CH 60 (5300MHz), and 802.11n HT20 CH 64 (5320MHz). A Remark section at the bottom states: '1. No other spurious found. 2. All results are PASS against Peak and Average limit line.'



Band 2 5250~5350MHz
WIFI 802.11n HT40 (Band Edge @ 3m)

WIFI Ant. 1	Note	Frequency (MHz)	Level (dBμV/m)	Over Limit (dB)	Limit Line (dBμV/m)	Read Level (dBμV)	Antenna Factor (dB/m)	Cable Loss (dB)	Preamp Factor (dB)	Ant Pos (cm)	Table Pos (deg)	Peak Avg. (P/A)	Pol. (H/V)
802.11n HT40 CH 54 5270MHz		5119.84	46.2	-27.8	74	43.64	31.2	7.91	36.55	100	122	P	H
		5113.6	36.65	-17.35	54	34.09	31.2	7.91	36.55	100	122	A	H
	*	5262	95.42	-	-	92.71	31.06	8.12	36.47	100	122	P	H
	*	5262	88.13	-	-	85.42	31.06	8.12	36.47	100	122	A	H
		5362.2	45.65	-28.35	74	42.72	30.96	8.39	36.42	100	122	P	H
		5351	36.54	-17.46	54	33.65	30.98	8.34	36.43	100	122	A	H
		5100.32	46.24	-27.76	74	43.68	31.22	7.9	36.56	301	103	P	V
		5107.04	36.63	-17.37	54	34.07	31.2	7.91	36.55	301	103	A	V
	*	5264	90.4	-	-	87.69	31.06	8.12	36.47	301	103	P	V
	*	5264	83.48	-	-	80.77	31.06	8.12	36.47	301	103	A	V
		5399	44.97	-29.03	74	41.97	30.93	8.48	36.41	301	103	P	V
		5351.5	35.96	-18.04	54	33.07	30.98	8.34	36.43	301	103	A	V
802.11n HT40 CH 62 5310MHz		5131.68	46.9	-27.1	74	44.34	31.19	7.91	36.54	100	127	P	H
		5100.64	36.63	-17.37	54	34.07	31.22	7.9	36.56	100	127	A	H
	*	5302	93.63	-	-	90.86	31.02	8.21	36.46	100	127	P	H
	*	5302	86.4	-	-	83.63	31.02	8.21	36.46	100	127	A	H
		5351.1	59.3	-14.7	74	56.41	30.98	8.34	36.43	100	127	P	H
	!	5350.1	48	-6	54	45.11	30.98	8.34	36.43	100	127	A	H
		5132.96	46.37	-27.63	74	43.81	31.19	7.91	36.54	327	109	P	V
		5101.6	36.59	-17.41	54	34.03	31.22	7.9	36.56	327	109	A	V
	*	5298	91.31	-	-	88.54	31.02	8.21	36.46	327	109	P	V
	*	5298	83.59	-	-	80.82	31.02	8.21	36.46	327	109	A	V
	5351.1	57.5	-16.5	74	54.61	30.98	8.34	36.43	327	109	P	V	
	5350.3	45.97	-8.03	54	43.08	30.98	8.34	36.43	327	109	A	V	
Remark	1. No other spurious found. 2. All results are PASS against Peak and Average limit line.												



Band 2 5250~5350MHz
WIFI 802.11n HT40 (Harmonic @ 3m)

Table with 14 columns: WIFI Ant. 1, Note, Frequency (MHz), Level (dBµV/m), Over Limit (dB), Limit Line (dBµV/m), Read Level (dBµV), Antenna Factor (dB/m), Cable Loss (dB), Preamp Factor (dB), Ant Pos (cm), Table Pos (deg), Peak Avg. (P/A), Pol. (H/V). Rows include data for 802.11n HT40 CH 54 at 10540MHz and 802.11n HT40 CH 62 at 10620MHz. A Remark section at the bottom states: '1. No other spurious found. 2. All results are PASS against Peak and Average limit line.'



Band 2 5250~5350MHz

Band 3 - 5470~5725MHz

WIFI 802.11a (Band Edge @ 3m)

WIFI Ant.	Note	Frequency	Level	Over Limit	Limit Line	Read Level	Antenna Factor	Cable Loss	Preamp Factor	Ant Pos	Table Pos	Peak Avg.	Pol.
1		(MHz)	(dBμV/m)	(dB)	(dBμV/m)	(dBμV)	(dB/m)	(dB)	(dB)	(cm)	(deg)	(P/A)	(H/V)
802.11a CH 100 5500MHz		5469.52	49.87	-24.13	74	47.03	30.86	8.35	36.37	100	114	P	H
		5470	40.41	-13.59	54	37.57	30.86	8.35	36.37	100	114	A	H
	*	5496	97.88	-	-	95.08	30.85	8.32	36.37	100	114	P	H
	*	5496	90.8	-	-	88	30.85	8.32	36.37	100	114	A	H
		5467.28	48.84	-25.16	74	46	30.86	8.35	36.37	316	301	P	V
		5469.52	39.38	-14.62	54	36.54	30.86	8.35	36.37	316	301	A	V
	*	5498	95.99	-	-	93.23	30.83	8.29	36.36	316	301	P	V
	*	5498	88.78	-	-	86.02	30.83	8.29	36.36	316	301	A	V
802.11a CH 116 5580MHz		5464.72	44.94	-29.06	74	42.1	30.86	8.35	36.37	100	116	P	H
		5451.28	35.85	-18.15	54	32.97	30.88	8.38	36.38	100	116	A	H
	*	5586	97.85	-	-	95.29	30.75	8.13	36.32	100	116	P	H
	*	5586	90.88	-	-	88.32	30.75	8.13	36.32	100	116	A	H
		5733.48	47.15	-26.85	74	43.8	31.32	8.31	36.28	100	116	P	H
		5735.24	36.93	-17.07	54	33.43	31.44	8.34	36.28	100	116	A	H
		5441.68	44.96	-29.04	74	42.05	30.89	8.41	36.39	300	109	P	V
		5448.72	35.94	-18.06	54	33.06	30.88	8.38	36.38	300	109	A	V
	*	5574	95.37	-	-	92.77	30.76	8.16	36.32	300	109	P	V
	*	5574	88.19	-	-	85.59	30.76	8.16	36.32	300	109	A	V
		5743.8	46.58	-27.42	74	43.08	31.44	8.34	36.28	300	109	P	V
		5745.96	36.89	-17.11	54	33.39	31.44	8.34	36.28	300	109	A	V



802.11a CH 140 5700MHz	*	5696	99.9	-	-	96.87	31.07	8.25	36.29	100	117	P	H
	*	5696	92.05	-	-	89.02	31.07	8.25	36.29	100	117	A	H
		5728.92	54.23	-19.77	74	50.88	31.32	8.31	36.28	100	117	P	H
		5725	44.42	-9.58	54	41.07	31.32	8.31	36.28	100	117	A	H
	*	5708	95.93	-	-	92.74	31.19	8.28	36.28	300	309	P	V
	*	5708	88.6	-	-	85.41	31.19	8.28	36.28	300	309	A	V
		5727.8	51.26	-22.74	74	47.91	31.32	8.31	36.28	300	309	P	V
		5725	41.98	-12.02	54	38.63	31.32	8.31	36.28	300	309	A	V
Remark	<ol style="list-style-type: none"> No other spurious found. All results are PASS against Peak and Average limit line. 												



Band 3 - 5470~5725MHz
WIFI 802.11a (Harmonic @ 3m)

Table with 14 columns: WIFI Ant. 1, Note, Frequency (MHz), Level (dBµV/m), Over Limit (dB), Limit Line (dBµV/m), Read Level (dBµV), Antenna Factor (dB/m), Cable Loss (dB), Preamp Factor (dB), Ant Pos (cm), Table Pos (deg), Peak Avg. (P/A), Pol. (H/V). Rows include channels 100, 116, and 140 with their respective frequency and measurement data.



Band 3 - 5470~5725MHz
WIFI 802.11n HT20 (Band Edge @ 3m)

Table with 14 columns: WIFI Ant. 1, Note, Frequency (MHz), Level (dBµV/m), Over Limit (dB), Limit Line (dBµV/m), Read Level (dBµV), Antenna Factor (dB/m), Cable Loss (dB), Preamp Factor (dB), Ant Pos (cm), Table Pos (deg), Peak Avg. (P/A), Pol. (H/V). Rows include data for 802.11n HT20 CH 100 (5500MHz) and 802.11n HT20 CH 116 (5580MHz).



802.11n HT20 CH 140 5700MHz	*	5694	98.86	-	-	95.83	31.07	8.25	36.29	100	126	P	H
	*	5694	91.38	-	-	88.35	31.07	8.25	36.29	100	126	A	H
		5725.08	61.76	-12.24	74	58.41	31.32	8.31	36.28	100	126	P	H
		5725	47.27	-6.73	54	43.92	31.32	8.31	36.28	100	126	A	H
	*	5704	95.89	-	-	92.7	31.19	8.28	36.28	314	315	P	V
	*	5704	88.36	-	-	85.17	31.19	8.28	36.28	314	315	A	V
		5725.08	54.39	-19.61	74	51.04	31.32	8.31	36.28	314	315	P	V
		5725	45.78	-8.22	54	42.43	31.32	8.31	36.28	314	315	A	V
Remark	1. No other spurious found. 2. All results are PASS against Peak and Average limit line.												



Band 3 - 5470~5725MHz
WIFI 802.11n HT20 (Harmonic @ 3m)

WIFI Ant. 1	Note	Frequency (MHz)	Level (dBμV/m)	Over Limit (dB)	Limit Line (dBμV/m)	Read Level (dBμV)	Antenna Factor (dB/m)	Cable Loss (dB)	Preamp Factor (dB)	Ant Pos (cm)	Table Pos (deg)	Peak Avg. (P/A)	Pol. (H/V)
802.11n HT20 CH 100 5500MHz		11000	42.25	-31.75	74	57.64	38.06	12.25	65.7	100	360	P	H
		11000	41.27	-32.73	74	56.66	38.06	12.25	65.7	100	360	P	V
802.11n HT20 CH 116 5580MHz		11160	42.44	-31.56	74	57.42	38.24	12.36	65.58	100	360	P	H
		11160	41.57	-32.43	74	56.55	38.24	12.36	65.58	100	360	P	V
802.11n HT20 CH 140 5700MHz		11400	41.74	-32.26	74	56.14	38.49	12.52	65.41	100	360	P	H
		11400	40.75	-33.25	74	55.15	38.49	12.52	65.41	100	360	P	V
Remark	1. No other spurious found. 2. All results are PASS against Peak and Average limit line.												



**Band 3 - 5470~5725MHz
WIFI 802.11n HT40 (Band Edge @ 3m)**

WIFI Ant. 1	Note	Frequency (MHz)	Level (dBμV/m)	Over Limit (dB)	Limit Line (dBμV/m)	Read Level (dBμV)	Antenna Factor (dB/m)	Cable Loss (dB)	Preamp Factor (dB)	Ant Pos (cm)	Table Pos (deg)	Peak Avg. (P/A)	Pol. (H/V)
802.11n HT40 CH 102 5510MHz		5469.2	60.44	-13.56	74	57.6	30.86	8.35	36.37	100	117	P	H
	!	5470	48.53	-5.47	54	45.69	30.86	8.35	36.37	100	117	A	H
	*	5498	92.65	-	-	89.89	30.83	8.29	36.36	100	117	P	H
	*	5498	85.7	-	-	82.94	30.83	8.29	36.36	100	117	A	H
		5731.4	46.83	-27.17	74	43.48	31.32	8.31	36.28	100	117	P	H
		5745.56	36.88	-17.12	54	33.38	31.44	8.34	36.28	100	117	A	H
		5465.36	57.69	-16.31	74	54.85	30.86	8.35	36.37	306	91	P	V
		5470	45.84	-8.16	54	43	30.86	8.35	36.37	306	91	A	V
	*	5514	89.72	-	-	87	30.81	8.26	36.35	306	91	P	V
	*	5514	83.07	-	-	80.35	30.81	8.26	36.35	306	91	A	V
		5764.04	46.62	-27.38	74	42.97	31.56	8.37	36.28	306	91	P	V
		5758.28	36.65	-17.35	54	33	31.56	8.37	36.28	306	91	A	V
802.11n HT40 CH 110 5550MHz		5454.32	45.7	-28.3	74	42.82	30.88	8.38	36.38	100	121	P	H
		5447.6	36.59	-17.41	54	33.71	30.88	8.38	36.38	100	121	A	H
	*	5564	93.79	-	-	91.14	30.78	8.2	36.33	100	121	P	H
	*	5564	86.67	-	-	84.02	30.78	8.2	36.33	100	121	A	H
		5741.16	46.41	-27.59	74	42.91	31.44	8.34	36.28	100	121	P	H
		5743.96	37.04	-16.96	54	33.54	31.44	8.34	36.28	100	121	A	H
		5443.92	45.31	-28.69	74	42.4	30.89	8.41	36.39	302	89	P	V
		5468.24	36.16	-17.84	54	33.32	30.86	8.35	36.37	302	89	A	V
	*	5536	91.74	-	-	89.05	30.8	8.23	36.34	302	89	P	V
	*	5536	84.31	-	-	81.62	30.8	8.23	36.34	302	89	A	V
	5734.2	46.95	-27.05	74	43.6	31.32	8.31	36.28	302	89	P	V	
	5743.88	36.75	-17.25	54	33.25	31.44	8.34	36.28	302	89	A	V	



802.11n HT40 CH 134 5670MHz		5457.52	44.63	-29.37	74	41.75	30.88	8.38	36.38	100	117	P	H
		5466.8	35.81	-18.19	54	32.97	30.86	8.35	36.37	100	117	A	H
	*	5684	95.53	-	-	92.5	31.07	8.25	36.29	100	117	P	H
	*	5684	88.14	-	-	85.11	31.07	8.25	36.29	100	117	A	H
		5731.24	50.94	-23.06	74	47.59	31.32	8.31	36.28	100	117	P	H
		5725.32	41.29	-12.71	54	37.94	31.32	8.31	36.28	100	117	A	H
		5423.44	45.05	-28.95	74	42.1	30.91	8.44	36.4	301	78	P	V
		5436.88	35.7	-18.3	54	32.79	30.89	8.41	36.39	301	78	A	V
	*	5676	92	-	-	89.12	30.95	8.22	36.29	301	78	P	V
	*	5676	84.2	-	-	81.32	30.95	8.22	36.29	301	78	A	V
		5727.56	49.08	-24.92	74	45.73	31.32	8.31	36.28	301	78	P	V
		5725.48	39.9	-14.1	54	36.55	31.32	8.31	36.28	301	78	A	V
Remark	<p>1. No other spurious found.</p> <p>2. All results are PASS against Peak and Average limit line.</p>												



Band 3 - 5470~5725MHz
WIFI 802.11n HT40 (Harmonic @ 3m)

Table with 14 columns: WIFI Ant. 1, Note, Frequency (MHz), Level (dBµV/m), Over Limit (dB), Limit Line (dBµV/m), Read Level (dBµV), Antenna Factor (dB/m), Cable Loss (dB), Preamp Factor (dB), Ant Pos (cm), Table Pos (deg), Peak Avg. (P/A), Pol. (H/V). Rows include channels 102 (5510MHz), 110 (5550MHz), and 134 (5670MHz) with their respective test results.



Band 3 - 5470~5725MHz

Emission below 1GHz

WIFI 802.11n HT40 (LF @ 3m)

WIFI Ant.	Note	Frequency	Level	Over Limit	Limit Line	Read Level	Antenna Factor	Cable Loss	Preamp Factor	Ant Pos	Table Pos	Peak Avg.	Pol.
1		(MHz)	(dBμV/m)	(dB)	(dBμV/m)	(dBμV)	(dB/m)	(dB)	(dB)	(cm)	(deg)	(P/A)	(H/V)
802.11n HT40 LF		34.85	32.28	-7.72	40	37.51	25.5	0.62	31.35	-	-	P	H
		57.16	28.27	-11.73	40	44.45	14.14	1.09	31.41	-	-	P	H
		159.01	36.08	-7.42	43.5	48.66	17.53	1.43	31.54	100	30	P	H
		198.78	34.65	-8.85	43.5	48.49	15.84	1.81	31.49	-	-	P	H
		268.62	31.29	-14.71	46	43.18	17.81	1.73	31.43	-	-	P	H
		478.14	26.88	-19.12	46	31.42	24.25	2.46	31.25	-	-	P	H
		32.91	32.11	-7.89	40	36.71	26.18	0.54	31.32	102	10	P	V
		43.58	31.71	-8.29	40	42.38	20	0.74	31.41	-	-	P	V
		92.08	27.22	-16.28	43.5	39.57	17.9	1.19	31.44	-	-	P	V
		196.84	29.05	-14.45	43.5	42.85	15.92	1.77	31.49	-	-	P	V
		407.33	24.76	-21.24	46	30.53	23.52	1.97	31.26	-	-	P	V
		692.51	27.66	-18.34	46	29.23	26.48	3.01	31.06	-	-	P	V
Remark	1. No other spurious found. 2. All results are PASS against limit line.												



Note symbol

*	Fundamental Frequency which can be ignored. However, the level of any unwanted emissions shall not exceed the level of the fundamental frequency.
!	Test result is over limit line.
P/A	Peak or Average
H/V	Horizontal or Vertical



A calculation example for radiated spurious emission is shown as below:

WIFI	Note	Frequency	Level	Over	Limit	Read	Antenna	Cable	Preamp	Ant	Table	Peak	Pol.
Ant.				Limit	Line	Level	Factor	Loss	Factor	Pos	Pos	Avg.	
1		(MHz)	(dBμV/m)	(dB)	(dBμV/m)	(dBμV)	(dB/m)	(dB)	(dB)	(cm)	(deg)	(P/A)	(H/V)
802.11b		2390	55.45	-18.55	74	54.51	32.22	4.58	35.86	103	308	P	H
CH 01													
2412MHz		2390	43.54	-10.46	54	42.6	32.22	4.58	35.86	103	308	A	H

$$1. \text{ Level(dB}\mu\text{V/m)} = \text{Antenna Factor(dB/m)} + \text{Cable Loss(dB)} + \text{Read Level(dB}\mu\text{V)} - \text{Preamp Factor(dB)}$$

$$2. \text{ Over Limit(dB)} = \text{Level(dB}\mu\text{V/m)} - \text{Limit Line(dB}\mu\text{V/m)}$$

For Peak Limit @ 2390MHz:

$$1. \text{ Level(dB}\mu\text{V/m)}$$

$$= \text{Antenna Factor(dB/m)} + \text{Cable Loss(dB)} + \text{Read Level(dB}\mu\text{V)} - \text{Preamp Factor(dB)}$$

$$= 32.22(\text{dB/m}) + 4.58(\text{dB}) + 54.51(\text{dB}\mu\text{V}) - 35.86(\text{dB})$$

$$= 55.45(\text{dB}\mu\text{V/m})$$

$$2. \text{ Over Limit(dB)}$$

$$= \text{Level(dB}\mu\text{V/m)} - \text{Limit Line(dB}\mu\text{V/m)}$$

$$= 55.45(\text{dB}\mu\text{V/m}) - 74(\text{dB}\mu\text{V/m})$$

$$= -18.55(\text{dB})$$

For Average Limit @ 2390MHz:

$$1. \text{ Level(dB}\mu\text{V/m)}$$

$$= \text{Antenna Factor(dB/m)} + \text{Cable Loss(dB)} + \text{Read Level(dB}\mu\text{V)} - \text{Preamp Factor(dB)}$$

$$= 32.22(\text{dB/m}) + 4.58(\text{dB}) + 42.6(\text{dB}\mu\text{V}) - 35.86(\text{dB})$$

$$= 43.54(\text{dB}\mu\text{V/m})$$

$$2. \text{ Over Limit(dB)}$$

$$= \text{Level(dB}\mu\text{V/m)} - \text{Limit Line(dB}\mu\text{V/m)}$$

$$= 43.54(\text{dB}\mu\text{V/m}) - 54(\text{dB}\mu\text{V/m})$$

$$= -10.46(\text{dB})$$

Both peak and average measured complies with the limit line, so test result is "PASS".



Appendix C. Duty Cycle Plots

Band	Duty Cycle(%)	T(ms)	1/T(kHz)	VBW Setting
802.11a	87.50	1.370	0.730	1kHz
802.11n HT20	85.99	1.272	0.786	1kHz
802.11n HT40	85.90	1.228	0.815	1kHz

802.11a

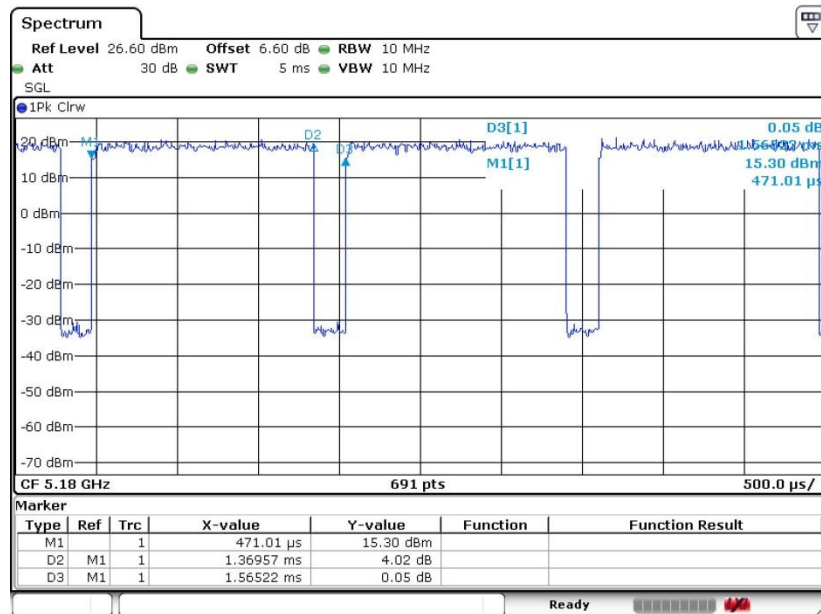

Date: 12 JUN 2017 20:01:56



802.11n HT20

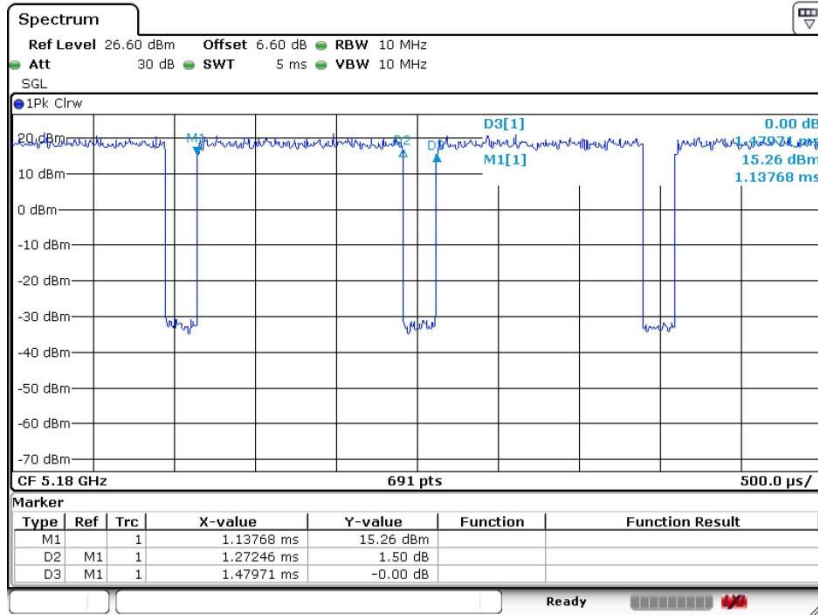

Date: 12 JUN 2017 20:08:51

802.11n HT40

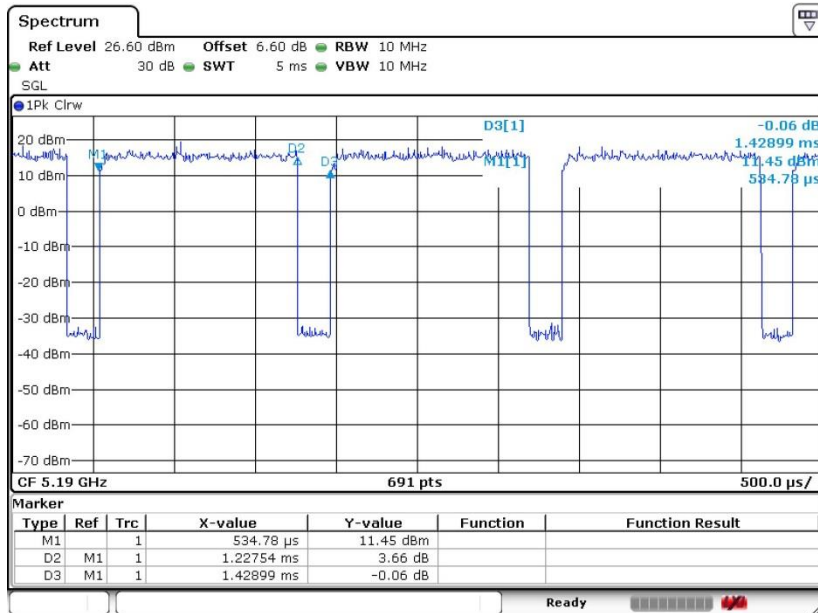

Date: 12 JUN 2017 20:25:17