

HAC_E_Dipole_835_170427

DUT: HAC-Dipole 835 MHz

Communication System: CW; Frequency: 835 MHz; Duty Cycle: 1:1
 Medium: Air Medium parameters used: $\sigma = 0$ S/m, $\epsilon_r = 1$; $\rho = 0$ kg/m³
 Ambient Temperature : 23.6 °C

DASY5 Configuration

- Probe: ER3DV6 - SN2358; ConvF(1, 1, 1); Calibrated: 2017/1/19;
- Sensor-Surface: (Fix Surface)
- Electronics: DAE4 Sn1424; Calibrated: 2017/2/16
- Phantom: HAC Test Arch with AMCC; Type: SD HAC P01 BA;
- Measurement SW: DASY52, Version 52.8 (8); SEMCAD X Version 14.6.10 (7373)

E Scan - measurement distance from the probe sensor center to CD835 = 10mm & 15mm/Hearing Aid Compatibility Test at 15mm distance (41x361x1): Interpolated grid:

dx=0.5000 mm, dy=0.5000 mm
 Device Reference Point: 0, 0, -6.3 mm
 Reference Value = 105.2 V/m; Power Drift = -0.09 dB
 PMR not calibrated. PMF = 1.000 is applied.
 E-field emissions = 109.3 V/m
 Average value of Total=(109.3+103.8) / 2 = 106.55 V/m

PMF scaled E-field

Grid 1 M4 107.9 V/m	Grid 2 M4 109.3 V/m	Grid 3 M4 107.3 V/m
Grid 4 M4 66.74 V/m	Grid 5 M4 67.09 V/m	Grid 6 M4 65.63 V/m
Grid 7 M4 103.0 V/m	Grid 8 M4 103.8 V/m	Grid 9 M4 101.2 V/m

Cursor:

Total = 109.3 V/m
 E Category: M4
 Location: 0.5, -69, 9.7 mm

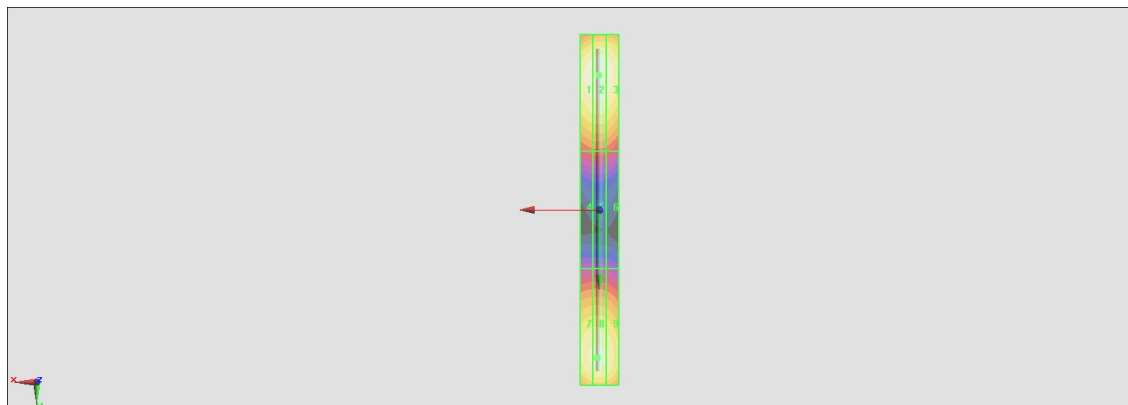
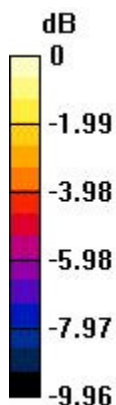

0 dB = 109.3 V/m = 40.77 dBV/m

HAC_E_Dipole_1880_170427

DUT: HAC Dipole 1880 MHz

Communication System: CW; Frequency: 1880 MHz; Duty Cycle: 1:1
 Medium: Air Medium parameters used: $\sigma = 0$ S/m, $\epsilon_r = 1$; $\rho = 0$ kg/m³
 Ambient Temperature : 23.6 °C

DASY5 Configuration

- Probe: ER3DV6 - SN2358; ConvF(1, 1, 1); Calibrated: 2017/1/19;
- Sensor-Surface: (Fix Surface)
- Electronics: DAE4 Sn1424; Calibrated: 2017/2/16
- Phantom: HAC Test Arch with AMCC; Type: SD HAC P01 BA;
- Measurement SW: DASY52, Version 52.8 (8); SEMCAD X Version 14.6.10 (7373)

E Scan - measurement distance from the probe sensor center to CD1880 = 10mm & 15mm/Hearing Aid Compatibility Test at 15mm distance (41x181x1): Interpolated grid:
 dx=0.5000 mm, dy=0.5000 mm

Device Reference Point: 0, 0, -6.3 mm

Reference Value = 150.3 V/m; Power Drift = -0.01 dB

PMR not calibrated. PMF = 1.000 is applied.

E-field emissions = 89.15 V/m

Average value of Total=(89.15+83.92) / 2 = 86.535 V/m

PMF scaled E-field

Grid 1 M3 87.74 V/m	Grid 2 M3 89.15 V/m	Grid 3 M3 87.05 V/m
Grid 4 M3 71.16 V/m	Grid 5 M3 71.48 V/m	Grid 6 M3 70.27 V/m
Grid 7 M3 83.05 V/m	Grid 8 M3 83.92 V/m	Grid 9 M3 81.97 V/m

Cursor:

Total = 89.15 V/m

E Category: M3

Location: 0.5, -30.5, 9.7 mm

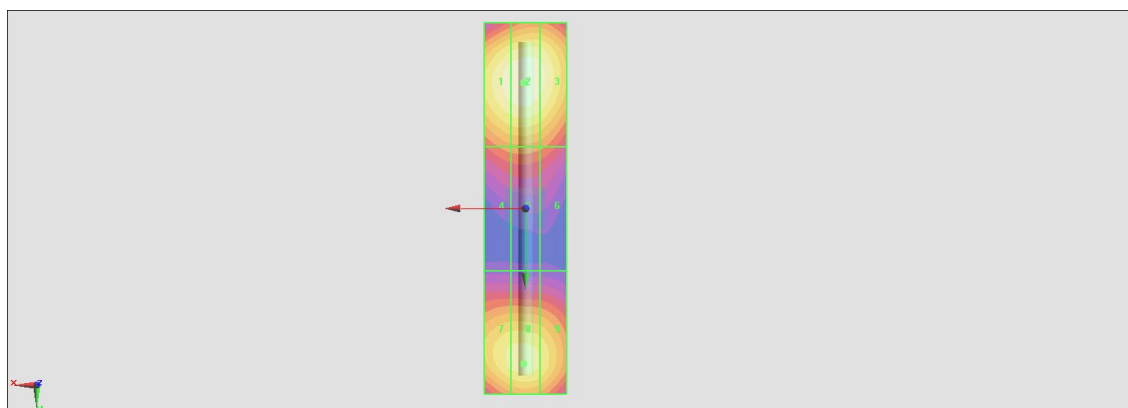
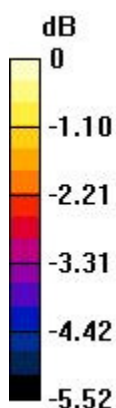

0 dB = 89.15 V/m = 39.00 dBV/m

HAC_E_Dipole_2600_170508

DUT: HAC Dipole 2600 MHz

Communication System: CW; Frequency: 2600 MHz; Duty Cycle: 1:1
 Medium: Air Medium parameters used: $\sigma = 0$ S/m, $\epsilon_r = 1$; $\rho = 0$ kg/m³
 Ambient Temperature : 23.2 °C

DASY5 Configuration

- Probe: ER3DV6 - SN2358; ConvF(1, 1, 1); Calibrated: 2017/1/19;
- Sensor-Surface: (Fix Surface)
- Electronics: DAE3 Sn577; Calibrated: 2016/9/28
- Phantom: HAC Test Arch with AMCC; Type: SD HAC P01 BA;
- Measurement SW: DASY52, Version 52.8 (8); SEMCAD X Version 14.6.10 (7373)

E Scan - measurement distance from the probe sensor center to CD2600 = 10mm & 15mm/Hearing Aid Compatibility Test at 15mm distance (41x181x1): Interpolated grid:
 dx=0.5000 mm, dy=0.5000 mm

Device Reference Point: 0, 0, -6.3 mm
 Reference Value = 72.73 V/m; Power Drift = 0.01 dB
 PMR not calibrated. PMF = 1.000 is applied.
 E-field emissions = 93.00 V/m
 Average value of Total=(86.59+93.00) / 2 = 89.795 V/m

PMF scaled E-field

Grid 1 M3 85.90 V/m	Grid 2 M3 86.59 V/m	Grid 3 M3 84.73 V/m
Grid 4 M3 87.61 V/m	Grid 5 M3 90.31 V/m	Grid 6 M3 89.50 V/m
Grid 7 M3 91.57 V/m	Grid 8 M3 93.00 V/m	Grid 9 M3 92.85 V/m

Cursor:

Total = 93.00 V/m

E Category: M3

Location: -0.5, 20.5, 9.7 mm

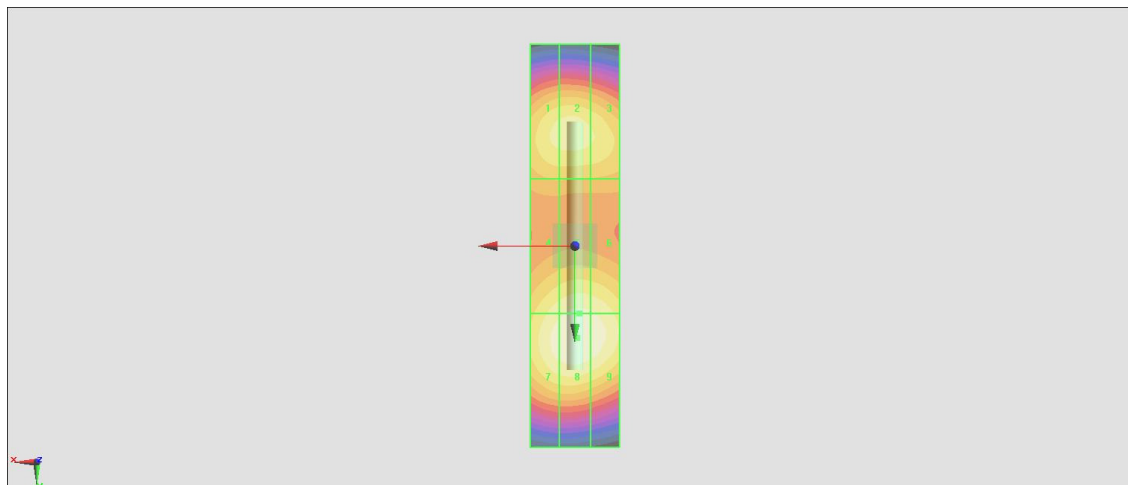
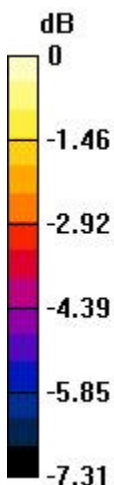

0 dB = 93.00 V/m = 39.46 dBV/m