



FCC RF Test Report

APPLICANT : Motorola Mobility, LLC
EQUIPMENT : Mobile Cellular Phone
BRAND NAME : Motorola
MODEL NAME : 10059
FCC ID : IHDT56WA5
STANDARD : 47 CFR Part 2, 22(H), 27
CLASSIFICATION : PCS Licensed Transmitter Held to Ear (PCE)

This is a variant report which is only valid together with the original test report. The product was received on Feb. 03, 2017 and completely tested on Mar. 10, 2017. We, SPORTON INTERNATIONAL INC., would like to declare that the tested sample has been evaluated in accordance with the test procedures given in ANSI / TIA / EIA-603-D-2010 and the testing has shown the tested sample to be in compliance with the applicable technical standards. The test results in this report apply exclusively to the tested model / sample. Without written approval of SPORTON INTERNATIONAL INC., the test report shall not be reproduced except in full.

Reviewed by: Joseph Lin / Supervisor

Approved by: Jones Tsai / Manager



Testing Laboratory
1190

SPORTON INTERNATIONAL INC.

No. 52, Hwa Ya 1st Rd., Hwa Ya Technology Park, Kwei-Shan District, Tao Yuan City, Taiwan, R.O.C.

SPORTON INTERNATIONAL INC.

TEL : 886-3-327-3456

FAX : 886-3-328-4978

FCC ID : IHDT56WA5

Page Number : 1 of 17

Report Issued Date : Mar. 20, 2017

Report Version : Rev. 01

Report Template No.: BU5-FGLTE Version 1.6



TABLE OF CONTENTS

REVISION HISTORY.....3
SUMMARY OF TEST RESULT4
1 GENERAL DESCRIPTION5
1.1 Applicant5
1.2 Manufacturer5
1.3 Product Feature of Equipment Under Test.....5
1.4 Product Specification of Equipment Under Test.....6
1.5 Modification of EUT6
1.6 Emission Designator7
1.7 Testing Location7
1.8 Applicable Standards8
2 TEST CONFIGURATION OF EQUIPMENT UNDER TEST9
2.1 Test Mode9
2.2 Connection Diagram of Test System9
2.3 Support Unit used in test configuration and system 10
2.4 Frequency List of Low/Middle/High Channels 10
3 CONDUCTED TEST ITEMS 11
3.1 Measuring Instruments 11
3.2 Test Setup 11
3.3 Test Result of Conducted Test 11
3.4 Conducted Output Power 11
4 RADIATED TEST ITEMS 12
4.1 Measuring Instruments 12
4.2 Test Setup 12
4.3 Test Result of Radiated Test 12
4.4 Effective Radiated Power and Effective Isotropic Radiated Power 13
4.5 Radiated Spurious Emission 15
5 LIST OF MEASURING EQUIPMENT 16
6 UNCERTAINTY OF EVALUATION 17
APPENDIX A. TEST RESULTS OF CONDUCTED TEST
APPENDIX B. TEST RESULTS OF ERP/EIRP AND RADIATED TEST
APPENDIX C. ORIGINAL REPORT



SUMMARY OF TEST RESULT

Report Section	FCC Rule	Description	Limit	Result	Remark
3.4	§2.1046	Conducted Output Power	Reporting Only	PASS	-
4.4	§22.913(a)(2)	Effective Radiated Power (Band 5)	ERP < 7 Watt	PASS	-
	§27.50(h)(2)	Equivalent Isotropic Radiated Power (Band 7)	EIRP < 2Watt		
4.5	§2.1053 §22.917(a)	Radiated Spurious Emission (Band 5)	< 43+10log10(P[Watts])	PASS	Under limit 24.13 dB at 10242.000 MHz
	§2.1053 §27.53(m)(4)	Radiated Spurious Emission (Band 7)	< 55+10log10(P[Watts])		



1 General Description

1.1 Applicant

Motorola Mobility, LLC

222 W Merchandise Mart Plaza, Suite 1800, Chicago, IL 60654, United States

1.2 Manufacturer

Motorola Mobility, LLC

222 W Merchandise Mart Plaza, Suite 1800, Chicago, IL 60654, United States

1.3 Product Feature of Equipment Under Test

Product Feature	
Equipment	Mobile Cellular Phone
Brand Name	Motorola
Model Name	10059
FCC ID	IHDT56WA5
IMEI Code	IMEI 1: 353302080001137 IMEI 2: 353302080001145
EUT supports Radios application	GSM/EGPRS/WCDMA/HSPA/LTE/NFC/FM WLAN 11b/g/n HT20 WLAN 11a/n HT20/HT40 Bluetooth BR/EDR/LE
HW Version	DVT2
EUT Stage	Identical Prototype

Remark:

1. The above EUT's information was declared by manufacturer. Please refer to the specifications or user's manual for more detailed description.
2. This is a variant report. All the test cases were performed on original report which can be referred to Sporton Report Number FG720310-04B.



Accessory List	
AC Adapter	Brand Name : Motorola
	Model Name : SPN5970A
Battery 1	Brand Name : Motorola
	Model Name : SNN5983A
Battery 2	Brand Name : Motorola
	Model Name : SNN5985A
Earphone	Brand Name : Motorola
	Model Name : SH38C16618
USB Cable	Brand Name : Motorola
	Model Name : SKN6473A

1.4 Product Specification of Equipment Under Test

Standards-related Product Specification	
Tx Frequency	LTE Band 5 : 824.7 MHz ~ 848.3 MHz
	LTE Band 7 : 2502.5 MHz ~ 2567.5 MHz
Rx Frequency	LTE Band 5 : 869.7 MHz ~ 893.3 MHz
	LTE Band 7 : 2622.5MHz ~ 2687.5 MHz
Bandwidth	LTE Band 5 : 1.4MHz / 3MHz / 5MHz / 10MHz
	LTE Band 7 : 5MHz / 10MHz / 15MHz / 20MHz
Maximum Output Power to Antenna	LTE Band 5 : 22.69 dBm
	LTE Band 7 : 22.60 dBm
Antenna Gain	LTE Band 5 : -2.30 dBi
	LTE Band 7 : -2.50 dBi
Type of Modulation	QPSK / 16QAM

1.5 Modification of EUT

No modifications are made to the EUT during all test items.



1.6 Emission Designator

LTE Band 5		QPSK			16QAM		
BW (MHz)	Frequency Range (MHz)	Emission Designator (99%OBW)	Frequency Tolerance (ppm)	Maximum ERP(W)	Emission Designator (99%OBW)	Frequency Tolerance (ppm)	Maximum ERP(W)
10	829.0 ~ 844.0	-	-	0.0524	-	-	0.0558
LTE Band 7		QPSK			16QAM		
BW (MHz)	Frequency Range (MHz)	Emission Designator (99%OBW)	Frequency Tolerance (ppm)	Maximum EIRP(W)	Emission Designator (99%OBW)	Frequency Tolerance (ppm)	Maximum EIRP(W)
15	2507.5 ~ 2562.5	-	-	-	-	-	0.1403
20	2510.0 ~ 2560.0	-	-	0.1648	-	-	-

1.7 Testing Location

Sporton Lab is accredited to ISO 17025 by Taiwan Accreditation Foundation (TAF code : 1190) and the FCC designation No. TW1190 under the FCC 2.948(e) by Mutual Recognition Agreement (MRA) in FCC Test.

Test Site	SPORTON INTERNATIONAL INC.	
Test Site Location	No. 52, Hwa Ya 1 st Rd., Hwa Ya Technology Park, Kwei-Shan District, Tao Yuan City, Taiwan, R.O.C. TEL: +886-3-327-3456 FAX: +886-3-328-4978	
Test Site No.	Sporton Site No.	
	TH05-HY	03CH07-HY



1.8 Applicable Standards

According to the specifications of the manufacturer, the EUT must comply with the requirements of the following standards:

- ♦ 47 CFR Part 2, 22(H), 27
- ♦ ANSI / TIA / EIA-603-D-2010
- ♦ FCC KDB 971168 D01 Power Meas. License Digital Systems v02r02

Remark:

1. All test items were verified and recorded according to the standards and without any deviation during the test.
2. This EUT has also been tested and complied with the requirements of FCC Part 15, Subpart B, recorded in a separate test report.

2 Test Configuration of Equipment Under Test

2.1 Test Mode

Antenna port conducted and radiated test items listed below are performed according to KDB 971168 D01 Power Meas. License Digital Systems v02r02 with maximum output power.

Radiated measurements are performed by rotating the EUT in three different orthogonal test planes to find the maximum emission.

Test Items	Band	Bandwidth (MHz)						Modulation		RB #			Test Channel		
		1.4	3	5	10	15	20	QPSK	16QAM	1	Half	Full	L	M	H
E.R.P./ E.I.R.P.	5				√	-	-	√	√	√			√	√	
	7	-	-			√	√	√	√	√					√
Radiated Spurious Emission	5				√	-	-	√		√				√	
	7	-	-		√			√		√					√
Note	<ol style="list-style-type: none"> The mark "√" means that this configuration is chosen for testing The mark "-" means that this bandwidth is not supported. The device is investigated from 30MHz to 10 times of fundamental signal for radiated spurious emission test under different RB size/offset and modulations in exploratory test. Subsequently, only the worst case emissions are reported. All the radiated test cases were performance with Battery 1. 														

2.2 Connection Diagram of Test System

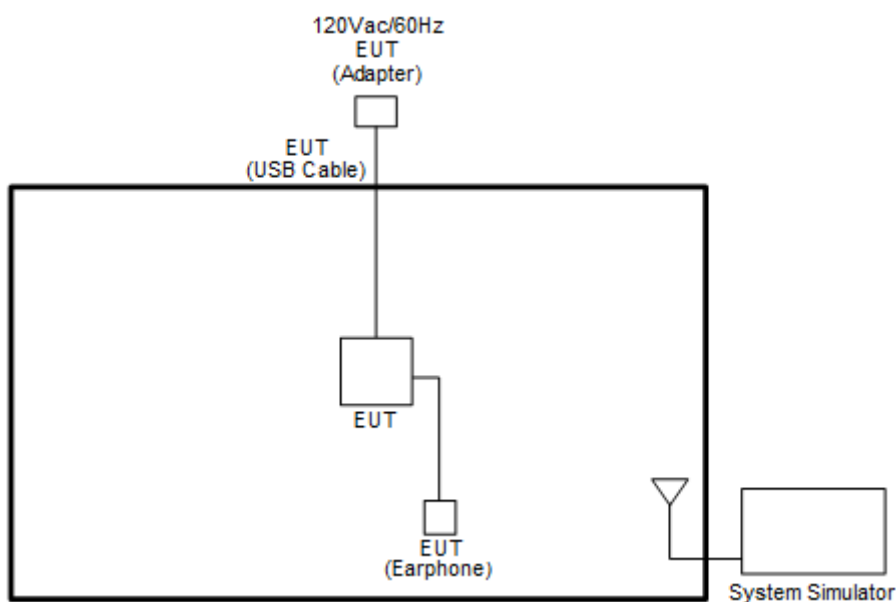



2.3 Support Unit used in test configuration and system

Item	Equipment	Trade Name	Model No.	FCC ID	Data Cable	Power Cord
1.	LTE Base Station	Anritsu	MT8820C	N/A	N/A	Unshielded, 1.8 m

2.4 Frequency List of Low/Middle/High Channels

LTE Band 5 Channel and Frequency List				
BW [MHz]	Channel/Frequency(MHz)	Lowest	Middle	Highest
10	Channel	20450	20525	-
	Frequency	829	836.5	-

LTE Band 7 Channel and Frequency List				
BW [MHz]	Channel/Frequency(MHz)	Lowest	Middle	Highest
20	Channel	-	-	21350
	Frequency	-	-	2560
15	Channel	-	-	21375
	Frequency	-	-	2562.5

3 Conducted Test Items

3.1 Measuring Instruments

See list of measuring instruments of this test report.

3.2 Test Setup

3.2.1 Conducted Output Power

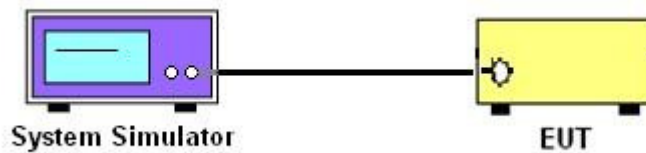

3.3 Test Result of Conducted Test

Please refer to Appendix A.

3.4 Conducted Output Power

3.4.1 Description of the Conducted Output Power Measurement

A system simulator was used to establish communication with the EUT. Its parameters were set to force the EUT transmitting at maximum output power. The measured power in the radio frequency on the transmitter output terminals shall be reported.

3.4.2 Test Procedures

1. The transmitter output port was connected to the system simulator.
2. Set EUT at maximum power through the system simulator.
3. Select lowest, middle, and highest channels for each band and different modulation.
4. Measure and record the power level from the system simulator.

4 Radiated Test Items

4.1 Measuring Instruments

See list of measuring instruments of this test report.

4.2 Test Setup

4.2.1 For radiated test from 30MHz to 1GHz

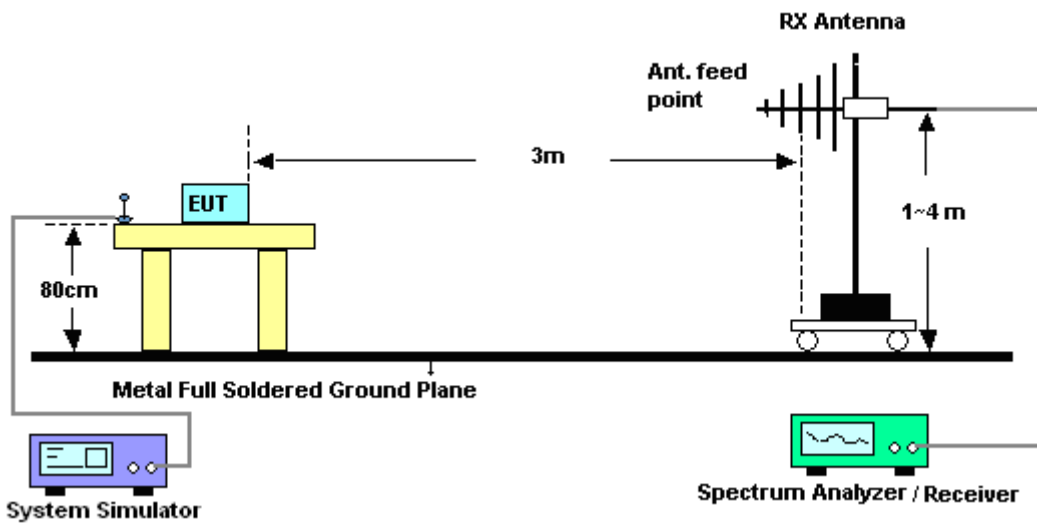

4.2.2 For radiated test above 1GHz

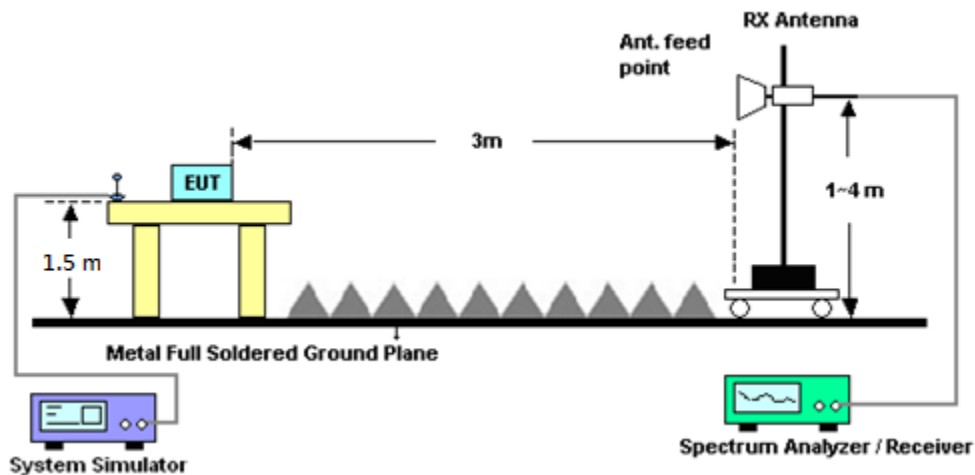

4.3 Test Result of Radiated Test

Please refer to Appendix B.



4.4 Effective Radiated Power and Effective Isotropic Radiated Power

4.4.1 Description of the ERP/EIRP Measurement

Effective radiated power output measurements by substitution method according to ANSI / TIA / EIA-603-D-2010, and the spectrum analyzer configuration follows KDB 971168 D01 Power Meas. License Digital Systems v02r02. Mobile and portable (hand-held) stations operating are limited to average ERP of 7 watts with LTE band 5.

Equivalent isotropic radiated power output measurements by substitution method according to ANSI / TIA / EIA-603-D-2010, and the spectrum analyzer configuration follows KDB 971168 D01 Power Meas. License Digital Systems v02r02. Mobile and portable (hand-held) stations operating are limited to average EIRP of 2 watts with LTE band 7.

4.4.2 Test Procedures

1. The EUT was placed on a non-conductive rotating platform (0.8 meters for frequency below 1GHz and 1.5 meter for frequency above 1GHz) in a semi-anechoic chamber. The radiated emission at the fundamental frequency was measured at 3 m with a test antenna and a spectrum analyzer with RMS detector per section 5. of KDB 971168 D01.
2. During the measurement, the system simulator parameters were set to force the EUT transmitting at maximum output power. The maximum emission was recorded from analyzer power level (LVL) from the 360 degrees rotation of the turntable and the test antenna raised and lowered over a range from 1 to 4 meters in both horizontally and vertically polarized orientations.
3. Effective Isotropic Radiated Power (EIRP) was measured by substitution method according to TIA/EIA-603-D. The EUT was replaced by the substitution antenna at same location, and then a known power from S.G. was applied into the dipole antenna through a Tx cable, and then recorded the maximum Analyzer reading through raised and lowered the test antenna. The correction factor (in dB) = S.G. - Tx Cable loss + Substitution antenna gain - Analyzer reading. Then the EUT's EIRP was calculated with the correction factor, $EIRP = LVL + \text{Correction factor}$ and $ERP = EIRP - 2.15$. Take the record of the output power at substitution antenna.



	LTE Average					
LTE BW	1.4M	3M	5M	10M	15M	20M
Span	3MHz	6MHz	10MHz	20MHz	30MHz	40MHz
RBW	30kHz	100kHz	100kHz	300kHz	300kHz	300kHz
VBW	100kHz	300kHz	300kHz	1MHz	1MHz	1MHz
Detector	RMS	RMS	RMS	RMS	RMS	RMS
Trace	Average	Average	Average	Average	Average	Average
Average Type	Power	Power	Power	Power	Power	Power
Sweep Count	100	100	100	100	100	100



4.5 Radiated Spurious Emission

4.5.1 Description of Radiated Spurious Emission

The radiated spurious emission was measured by substitution method according to ANSI / TIA / EIA-603-D-2010. The power of any emission outside of the authorized operating frequency ranges must be attenuated below the transmitter power (P) by a factor of at least $43 + 10 \log (P)$ dB.

For Band 7

The power of any emission outside of the authorized operating frequency ranges must be attenuated below the transmitter power (P) by a factor of at least $55 + 10 \log (P)$ dB.

The spectrum is scanned from 30 MHz up to a frequency including its 10th harmonic.

4.5.2 Test Procedures

1. The testing follows FCC KDB 971168 v02r02 Section 5.8 and ANSI / TIA-603-D-2010 Section 2.2.12.
2. The EUT was placed on a turntable with 0.8 meter for frequency below 1GHz and 1.5 meter for frequency above 1GHz respectively above ground.
3. The EUT was set 3 meters from the receiving antenna, which was mounted on the antenna tower.
4. The table was rotated 360 degrees to determine the position of the highest spurious emission.
5. The height of the receiving antenna is varied between one meter and four meters to search the maximum spurious emission for both horizontal and vertical polarizations.
6. Make the measurement with the spectrum analyzer's RBW = 1MHz, VBW = 3MHz, taking the record of maximum spurious emission.
7. A horn antenna was substituted in place of the EUT and was driven by a signal generator.
8. Tune the output power of signal generator to the same emission level with EUT maximum spurious emission.
9. Taking the record of output power at antenna port.
10. Repeat step 7 to step 8 for another polarization.
11. The RF fundamental frequency should be excluded against the limit line in the operating frequency band.

The limit line is derived from $43 + 10\log(P)$ dB below the transmitter power P(Watts)

12. For Band 7:

The limit line is derived from $55 + 10\log(P)$ dB below the transmitter power P(Watts)

EIRP (dBm) = S.G. Power – Tx Cable Loss + Tx Antenna Gain

ERP (dBm) = EIRP - 2.15



5 List of Measuring Equipment

Instrument	Manufacturer	Model No.	Serial No.	Characteristics	Calibration Date	Test Date	Due Date	Remark
LTE Base Station	Anritsu	MT8820C	6201432821	GSM/GPRS /WCDMA/LTE	Oct. 11, 2016	Feb. 21, 2017	Oct. 10, 2017	Conducted (TH05-HY)
Bilog Antenna	TESEQ	CBL 6111D&0080 0N1D01N-06	35419&03	30MHz to 1GHz	Jan. 07, 2017	Mar. 02, 2017 ~ Mar. 10, 2017	Jan. 06, 2018	Radiation (03CH07-HY)
Double Ridge Horn Antenna	ESCO	3117	00075962	1GHz ~ 18GHz	Aug. 19, 2016	Mar. 02, 2017 ~ Mar. 10, 2017	Aug. 18, 2017	Radiation (03CH07-HY)
EMI Test Receiver	Keysight	N9038A(MX E)	MY54130085	20Hz ~ 8.4GHz	Oct. 26, 2016	Mar. 02, 2017 ~ Mar. 10, 2017	Oct. 25, 2017	Radiation (03CH07-HY)
Loop Antenna	Rohde & Schwarz	HFH2-Z2	100315	9 kHz~30 MHz	Sep. 02, 2015	Mar. 02, 2017 ~ Mar. 10, 2017	Sep. 01, 2017	Radiation (03CH07-HY)
Preamplifier	MITEQ	AMF-7D-001 01800-30-10 P	1590075	1GHz ~ 18GHz	Apr. 15, 2016	Mar. 02, 2017 ~ Mar. 10, 2017	Apr. 14, 2017	Radiation (03CH07-HY)
Preamplifier	COM-POWER	PA-103A	161241	10MHz-1GHz	Mar. 18, 2016	Mar. 02, 2017 ~ Mar. 10, 2017	Mar. 17, 2017	Radiation (03CH07-HY)
Spectrum Analyzer	Agilent	N9030A	MY52350276	3Hz~44GHz	Mar. 21, 2016	Mar. 02, 2017 ~ Mar. 10, 2017	Mar. 20, 2017	Radiation (03CH07-HY)
Antenna Mast	Max-Full	MFA520BS	N/A	1m~4m	N/A	Mar. 02, 2017 ~ Mar. 10, 2017	N/A	Radiation (03CH07-HY)
Turn Table	ChainTek	Chaintek 3000	N/A	0~360 Degree	N/A	Mar. 02, 2017 ~ Mar. 10, 2017	N/A	Radiation (03CH07-HY)
Preamplifier	MITEQ	JS44-18004 000-33-8P	1840917	18GHz ~ 40GHz	Jun. 14, 2016	Mar. 02, 2017 ~ Mar. 10, 2017	Jun. 13, 2017	Radiation (03CH07-HY)
SHF-EHF Horn Antenna	SCHWARZBEC K	BBHA 9170	BBHA917058 4	18GHz- 40GHz	Nov. 08, 2016	Mar. 02, 2017 ~ Mar. 10, 2017	Nov. 07, 2017	Radiation (03CH07-HY)
Signal Generator	Anritsu	MG3694C	163401	0.1Hz~40GHz	Jan. 04, 2017	Mar. 02, 2017 ~ Mar. 10, 2017	Jan. 03, 2018	Radiation (03CH07-HY)



6 Uncertainty of Evaluation

Uncertainty of Radiated Emission Measurement (30 MHz ~ 1000 MHz)

Measuring Uncertainty for a Level of Confidence of 95% ($U = 2Uc(y)$)	5.7
---	-----

Uncertainty of Radiated Emission Measurement (1 GHz ~ 18 GHz)

Measuring Uncertainty for a Level of Confidence of 95% ($U = 2Uc(y)$)	5.5
---	-----

Uncertainty of Radiated Emission Measurement (18 GHz ~ 40 GHz)

Measuring Uncertainty for a Level of Confidence of 95% ($U = 2Uc(y)$)	5.2
---	-----



Appendix A. Test Results of Conducted Test

Conducted Output Power(Average power)

LTE Band 5 Maximum Average Power [dBm]						
BW [MHz]	RB Size	RB Offset	Mod	Lowest	Middle	Highest
10	1	0	QPSK	22.65	22.69	22.54
10	1	25		22.48	22.38	22.52
10	1	49		22.58	22.60	22.51
10	25	0		21.45	21.49	21.42
10	25	12		21.50	21.50	21.53
10	25	25		21.55	21.57	21.56
10	50	0		21.47	21.52	21.43
10	1	0	16-QAM	21.81	21.69	21.77
10	1	25		21.57	21.57	21.66
10	1	49		21.88	21.88	21.72
10	25	0		20.43	20.45	20.44
10	25	12		20.47	20.51	20.52
10	25	25		20.46	20.50	20.52
10	50	0		20.51	20.43	20.50
5	1	0	QPSK	22.40	22.37	22.43
5	1	12		22.32	22.23	22.44
5	1	24		22.39	22.35	22.37
5	12	0		21.42	21.44	21.50
5	12	7		21.41	21.38	21.57
5	12	13		21.47	21.40	21.38
5	25	0		21.39	21.35	21.45
5	1	0	16-QAM	21.66	21.60	21.67
5	1	12		21.54	21.57	21.60
5	1	24		21.60	21.59	21.49
5	12	0		20.47	20.43	20.52
5	12	7		20.43	20.39	20.51
5	12	13		20.44	20.39	20.45
5	25	0		20.38	20.38	20.51



LTE Band 5 Maximum Average Power [dBm]						
BW [MHz]	RB Size	RB Offset	Mod	Lowest	Middle	Highest
3	1	0	QPSK	22.40	22.34	22.41
3	1	8		22.36	22.30	22.37
3	1	14		22.27	22.30	22.34
3	8	0		21.44	21.44	21.39
3	8	4		21.41	21.38	21.42
3	8	7		21.35	21.37	21.43
3	15	0		21.37	21.30	21.42
3	1	0	16-QAM	21.61	21.55	21.67
3	1	8		21.59	21.55	21.59
3	1	14		21.47	21.54	21.49
3	8	0		20.51	20.47	20.47
3	8	4		20.45	20.38	20.50
3	8	7		20.42	20.38	20.46
3	15	0		20.41	20.33	20.42
1.4	1	0	QPSK	22.33	22.33	22.24
1.4	1	3		22.38	22.29	22.32
1.4	1	5		22.28	22.23	22.29
1.4	3	0		22.33	22.34	22.31
1.4	3	1		22.38	22.41	22.37
1.4	3	3		22.32	22.28	22.32
1.4	6	0		21.38	21.29	21.37
1.4	1	0	16-QAM	21.58	21.54	21.58
1.4	1	3		21.62	21.54	21.60
1.4	1	5		21.54	21.48	21.49
1.4	3	0		21.38	21.37	21.31
1.4	3	1		21.43	21.44	21.38
1.4	3	3		21.35	21.24	21.29
1.4	6	0		20.49	20.38	20.47



LTE Band 7 Maximum Average Power [dBm]						
BW [MHz]	RB Size	RB Offset	Mod	Lowest	Middle	Highest
20	1	0	QPSK	22.35	22.13	22.18
20	1	49		22.47	22.35	22.60
20	1	99		22.22	22.27	22.45
20	50	0		21.51	21.35	21.54
20	50	24		21.64	21.47	21.56
20	50	50		21.51	21.33	21.51
20	100	0		21.52	21.31	21.56
20	1	0	16-QAM	21.63	21.58	21.61
20	1	49		21.82	21.64	21.82
20	1	99		21.51	21.49	21.73
20	50	0		20.51	20.36	20.52
20	50	24		20.64	20.49	20.54
20	50	50		20.57	20.37	20.58
20	100	0		20.54	20.29	20.57
15	1	0	QPSK	22.27	22.14	22.18
15	1	37		22.35	22.32	22.53
15	1	74		22.32	22.27	22.36
15	36	0		21.52	21.35	21.40
15	36	20		21.51	21.38	21.61
15	36	39		21.43	21.30	21.58
15	75	0		21.48	21.39	21.48
15	1	0	16-QAM	21.60	21.45	21.58
15	1	37		21.61	21.49	21.78
15	1	74		21.62	21.48	21.63
15	36	0		20.52	20.35	20.47
15	36	20		20.51	20.40	20.62
15	36	39		20.45	20.27	20.58
15	75	0		20.49	20.34	20.46



LTE Band 7 Maximum Average Power [dBm]						
BW [MHz]	RB Size	RB Offset	Mod	Lowest	Middle	Highest
10	1	0	QPSK	22.59	22.36	22.51
10	1	25		22.56	22.30	22.48
10	1	49		22.55	22.36	22.59
10	25	0		21.68	21.45	21.54
10	25	12		21.54	21.38	21.54
10	25	25		21.57	21.39	21.49
10	50	0		21.57	21.44	21.48
10	1	0	16-QAM	21.96	21.69	21.89
10	1	25		21.75	21.57	21.75
10	1	49		21.94	21.60	21.76
10	25	0		20.72	20.46	20.58
10	25	12		20.62	20.36	20.56
10	25	25		20.58	20.35	20.50
10	50	0		20.60	20.38	20.48
5	1	0	QPSK	22.52	22.27	22.33
5	1	12		22.55	22.28	22.42
5	1	24		22.50	22.25	22.45
5	12	0		21.68	21.42	21.53
5	12	7		21.66	21.41	21.53
5	12	13		21.65	21.38	21.51
5	25	0		21.69	21.44	21.55
5	1	0	16-QAM	21.86	21.64	21.74
5	1	12		21.79	21.49	21.70
5	1	24		21.74	21.56	21.74
5	12	0		20.72	20.47	20.57
5	12	7		20.70	20.43	20.52
5	12	13		20.65	20.39	20.51
5	25	0		20.71	20.41	20.53



Appendix B. Test Results of ERP/EIRP and Radiated Test

ERP/EIRP

LTE Band 5 / 10MHz (Average)							
Channel	Mode	RB		Horizontal		Vertical	
		Size	Offset	ERP(dBm)	ERP(W)	ERP(dBm)	ERP(W)
Lowest	QPSK	1	0	16.15	0.0412	17.19	0.0524
Lowest	16QAM	1	49	16.64	0.0461	17.47	0.0558
Limit	ERP < 7W			Result		PASS	

LTE Band 7 / 15MHz (Average)							
Channel	Mode	RB		Horizontal		Vertical	
		Size	Offset	EIRP(dBm)	EIRP(W)	EIRP(dBm)	EIRP(W)
Highest	16QAM	1	37	20.45	0.1109	21.47	0.1403
Limit	EIRP < 2W			Result		PASS	

LTE Band 7 / 20MHz (Average)							
Channel	Mode	RB		Horizontal		Vertical	
		Size	Offset	EIRP(dBm)	EIRP(W)	EIRP(dBm)	EIRP(W)
Highest	QPSK	1	49	21.22	0.1324	22.17	0.1648
Limit	EIRP < 2W			Result		PASS	



Radiated Spurious Emission

LTE Band 5

LTE Band 5 / 10MHz / QPSK									
Channel	Frequency (MHz)	ERP (dBm)	Limit (dBm)	Over Limit (dB)	SPA Reading (dBm)	S.G. Power (dBm)	TX Cable loss (dB)	TX Antenna Gain (dBi)	Polarization (H/V)
Middle	1664	-54.55	-13	-41.55	-42.21	-56.26	0.98	4.84	H
	2496	-63.58	-13	-50.58	-56.66	-65.53	1.29	5.39	H
	3328	-65.28	-13	-52.28	-60.5	-68.82	1.55	7.24	H
									H
									H
									H
									H
	1664	-53.87	-13	-40.87	-42.03	-55.58	0.98	4.84	V
	2496	-59.96	-13	-46.96	-53.52	-61.91	1.29	5.39	V
	3328	-64.38	-13	-51.38	-59.83	-67.92	1.55	7.24	V
									V
									V
									V
									V

Remark: Spurious emissions within 30-1000MHz were found more than 20dB below limit line.



LTE Band 7

LTE Band 7 / 10MHz / QPSK									
Channel	Frequency (MHz)	EIRP (dBm)	Limit (dBm)	Over Limit (dB)	SPA Reading (dBm)	S.G. Power (dBm)	TX Cable loss (dB)	TX Antenna Gain (dBi)	Polarization (H/V)
Highest	5124	-62.88	-25	-37.88	-63.16	-70.17	2.41	9.70	H
	7680	-59.94	-25	-34.94	-64.46	-69.48	2.37	11.91	H
	10242	-54.33	-25	-29.33	-62.46	-63.93	2.69	12.30	H
	15372	-56.54	-25	-31.54	-70.67	-66.91	3.75	14.12	H
									H
									H
									H
	5124	-62.66	-25	-37.66	-62.78	-69.95	2.41	9.70	V
	7680	-59.17	-25	-34.17	-64.02	-68.71	2.37	11.91	V
	10242	-49.13	-25	-24.13	-57.2	-58.73	2.69	12.30	V
	15372	-54.26	-25	-29.26	-68.41	-64.63	3.75	14.12	V
									V
									V
									V

Remark: Spurious emissions within 30-1000MHz were found more than 20dB below limit line.



Appendix C. Original Report

Please refer to Sporton report number FG720310-04B.