



FCC RF Test Report

APPLICANT : Motorola Mobility, LLC
EQUIPMENT : Mobile Cellular Phone
BRAND NAME : Motorola
MODEL NAME : 9653
FCC ID : IHDT56WA1
STANDARD : FCC Part 15 Subpart C §15.225
CLASSIFICATION : (DXX) Low Power Communication Device Transmitter

This is a variant report which is only valid together with the original test report. The testing was completed on May 04, 2017. We, SPORTON INTERNATIONAL INC., would like to declare that the tested sample has been evaluated in accordance with the test procedures and has been in compliance with the applicable technical standards.

The test results in this report apply exclusively to the tested model / sample. Without written approval of SPORTON INTERNATIONAL INC., the test report shall not be reproduced except in full.

Reviewed by: Joseph Lin / Supervisor

Approved by: Jones Tsai / Manager



SPORTON INTERNATIONAL INC.

No. 52, Hwa Ya 1st Rd., Hwa Ya Technology Park, Kwei-Shan District, Tao Yuan City, Taiwan, R.O.C.



TABLE OF CONTENTS

SUMMARY OF THE TEST RESULT4

1. GENERAL INFORMATION.....5

1.1 Applicant..... 5

1.2 Manufacturer 5

1.3 Product Feature of Equipment Under Test 5

1.4 Product Specification of Equipment Under Test 6

1.5 Modification of EUT 6

1.6 Testing Location 7

1.7 Applicable Standards..... 7

2. TEST CONFIGURATION OF EQUIPMENT UNDER TEST8

2.1 Descriptions of Test Mode 8

2.2 Connection Diagram of Test System 9

2.3 Table for Supporting Units 11

2.4 EUT Operation Test Setup 11

3. TEST RESULTS.....12

3.1 AC Power Line Conducted Emissions Measurement 12

3.2 Field Strength of Fundamental Emissions and Mask Measurement..... 14

3.3 Radiated Emissions Measurement 16

3.4 Antenna Requirements..... 19

4. LIST OF MEASURING EQUIPMENT20

APPENDIX A. TEST RESULTS OF CONDUCTED EMISSION TEST

APPENDIX B. TEST RESULTS OF RADIATED TEST ITEMS

B1. Test Result of Field Strength of Fundamental Emissions

B2. Results of Radiated Emissions (9 kHz~30MHz)

B3. Results of Radiated Emissions (30MHz~1GHz)



SUMMARY OF THE TEST RESULT

Applied Standard: 47 CFR FCC Part 15 Subpart C				
Part	FCC Rule	Description of Test	Result	Remark
3.1	15.207	AC Power Line Conducted Emissions	Complies	Under Limit 3.70 dB at 0.238MHz
3.2	15.225(a)(b)(c)	Field Strength of Fundamental Emissions	Complies	Max level 65.97 dB at 13.560 MHz
3.3	15.225(d) 15.209	Radiated Emissions	Complies	Under Limit 4.62 dB at 57.810 MHz
3.4	15.203	Antenna Requirements	Complies	-

Test Items	Uncertainty	Remark
AC Power Line Conducted Emissions	±2.70dB	Confidence levels of 95%
Radiated Emissions (30MHz~1000MHz)	±5.20dB	Confidence levels of 95%



1. GENERAL INFORMATION

1.1 Applicant

Motorola Mobility, LLC

222 W Merchandise Mart Plaza, Suite 1800, Chicago, IL 60654, United States

1.2 Manufacturer

Motorola Mobility, LLC

222 W Merchandise Mart Plaza, Suite 1800, Chicago, IL 60654, United States

1.3 Product Feature of Equipment Under Test

Product Feature	
Equipment	Mobile Cellular Phone
Brand Name	Motorola
Model Name	9653
FCC ID	IHDT56WA1
IMEI Code	351884080020995
EUT supports Radios application	CDMA/EV-DO/GSM/EGPRS/WCDMA/HSPA/LTE/NFC/FM WLAN 11b/g/n HT20 WLAN 11a/n HT20/HT40 Bluetooth BR/EDR/LE
EUT Stage	Identical Prototype

Remark:

1. The above EUT's information was declared by manufacturer. Please refer to the specifications or user's manual for more detailed description.
2. This is a variant report by adding WPC Back cover. All the test cases were performed on original report which can be referred to Sporton Report Number FR720310D. Based on the original report, only worst case was verified.

Accessory List	
WPC Cover	Brand Name : Motorola
	Model Name : MD100W



1.4 Product Specification of Equipment Under Test

Standards-related Product Specification	
Tx/Rx Frequency Range	13.553 ~ 13.567MHz
Channel Number	1
Antenna Type	Fixed Internal Antenna
Type of Modulation	ASK

Remark: The above EUT's information was declared by manufacturer. Please refer to the specifications or user's manual for more detailed description.

1.5 Modification of EUT

No modifications are made to the EUT during all test items.

1.6 Testing Location

Sporton Lab is accredited to ISO 17025 by Taiwan Accreditation Foundation (TAF code : 1190) and the FCC designation No. TW0007 under the FCC 2.948(e) by Mutual Recognition Agreement (MRA) in FCC Test.

Test Site	SPORTON INTERNATIONAL INC.
Test Site Location	No. 52, Hwa Ya 1 st Rd., Hwa Ya Technology Park, Kwei-Shan District, Tao Yuan City, Taiwan, R.O.C. TEL: +886-3-3273456 / FAX: +886-3-3284978
Test Site No.	Sporton Site No.
	CO05-HY
Test Engineer	Marlowe Ho
Temperature	23~24°C
Relative Humidity	60~62%

Note: The test site complies with ANSI C63.4 2014 requirement.

Test Site	SPORTON INTERNATIONAL INC.
Test Site Location	No.58, Aly. 75, Ln. 564, Wenhua 3rd Rd. Guishan Dist, Taoyuan City, Taiwan (R.O.C.) TEL: +886-3-327-0868 / FAX: +886-3-327-0855
Test Site No.	Sporton Site No.
	03CH11-HY
Test Engineer	Jesse Wang
Temperature	21~24°C
Relative Humidity	51~54%

1.7 Applicable Standards

According to the specifications of the manufacturer, the EUT must comply with the requirements of the following standards:

- ♦ FCC Part 15 Subpart C §15.225
- ♦ ANSI C63.10-2013



2. TEST CONFIGURATION OF EQUIPMENT UNDER TEST

2.1 Descriptions of Test Mode

Investigation has been done on all the possible configurations for searching the worst cases.

The following table is a list of the test modes shown in this test report.

Test Items	
AC Power Line Conducted Emissions	Field Strength of Fundamental Emissions
Radiated Emissions 9kHz~30MHz	Radiated Emissions 30MHz~1GHz

The EUT pre-scanned in four NFC type, A, B, F, V. The worst type (type F) was recorded in this report.

2.2 Connection Diagram of Test System

<AC Conducted Emissions with WPC Charging Mode>

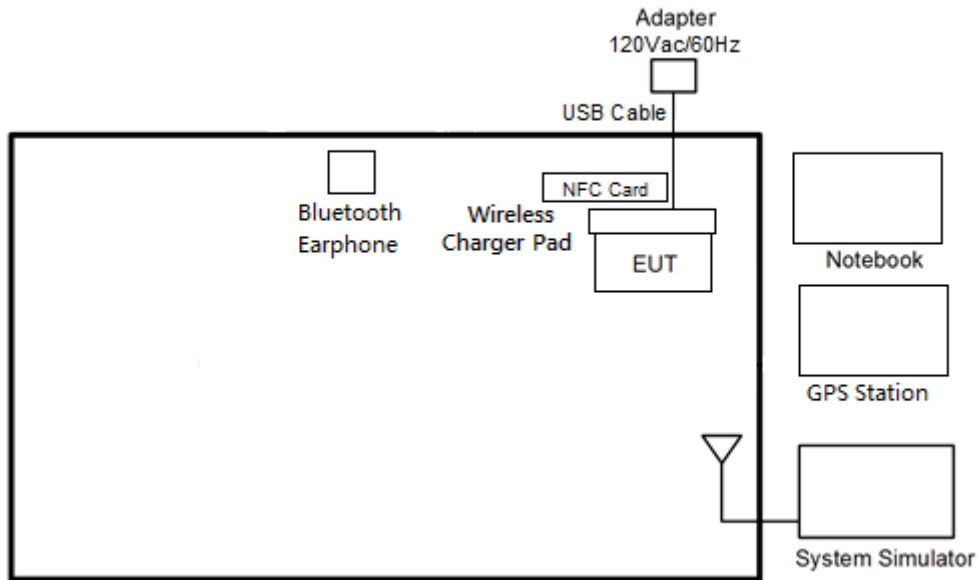

<AC Conducted Emissions with PAM Charging Mode>

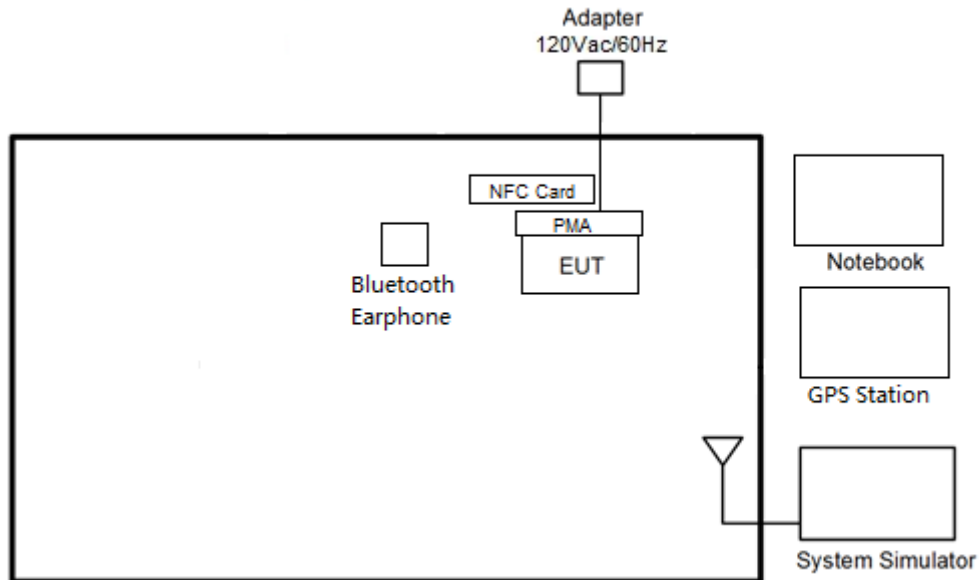

< For Fundamental Emissions and Mask and Radiated Emissions Measurement >

<WPC Charging Mode>

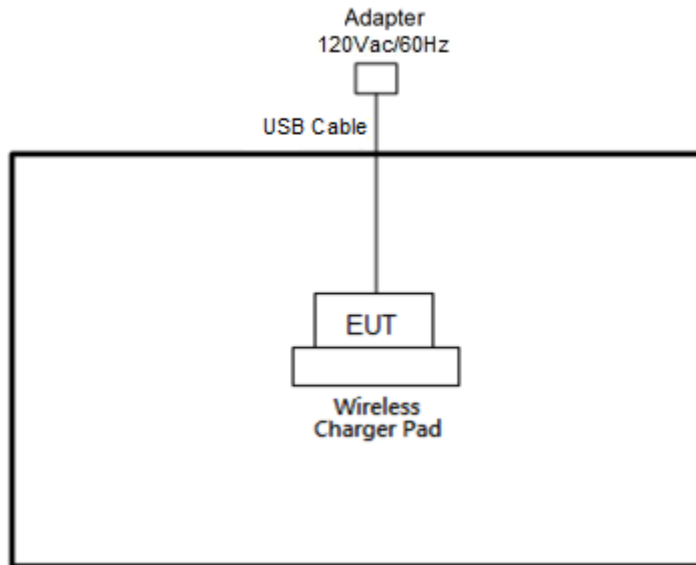

<PMA Charging Mode>

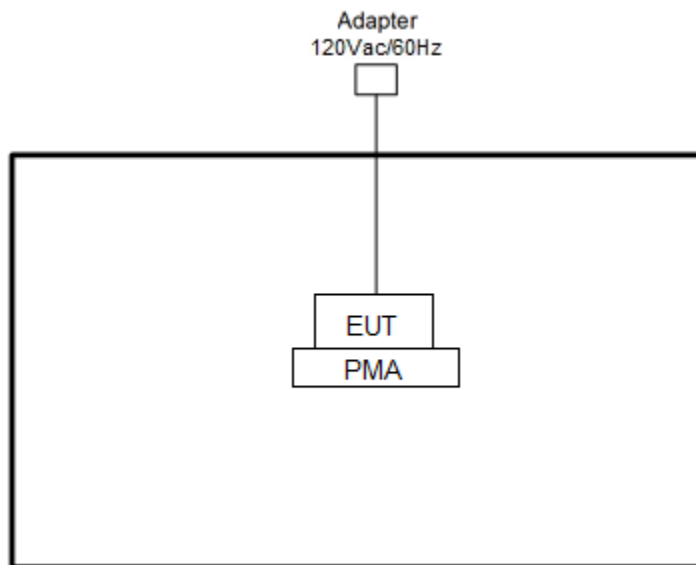



2.3 Table for Supporting Units

Support Unit	Manufacturer	Model	FCC ID
Base Station	Anritsu	MT8820C	N/A
Bluetooth Earphone	SonyEricsson	MW600	PY700A2029
WLAN AP	ASUS	RT-AC66U	MSQ-RTAC66U
SD Card	Transcend	MicroSD HC 16G	FCC DoC
Adapter	HUAWEI	HW-059200UHQ	FCC DoC
USB Cable	HUAWEI	N/A	FCC DoC
WPC Pad	LG	WCD-100	FCC DoC
PMA Pad	DURACELL	M-018B-518A	FCC DoC
NOTE BOOK	DELL	Latitude E6320	FCC DoC
NFC Card	Metro Taipei	Easy Card (A)	N/A

2.4 EUT Operation Test Setup

The EUT was programmed to be in continuously transmitting mode.

The ancillary equipment, NFC card, is used to make the EUT (NFC) continuously transmit at 13.56MHz and is placed around 0 cm gap to the EUT.



3. TEST RESULTS

3.1 AC Power Line Conducted Emissions Measurement

3.1.1 Limit of AC Conducted Emission

For equipment that is designed to be connected to the public utility (AC) power line, the radio frequency voltage that is conducted back onto the AC power line on any frequency or frequencies within the band 150 kHz to 30 MHz shall not exceed the limits in the following table.

Frequency of Emission (MHz)	Conducted Limit (dB μ V)	
	Quasi-Peak	Average
0.15-0.5	66 to 56*	56 to 46*
0.5-5	56	46
5-30	60	50

*Decreases with the logarithm of the frequency.

3.1.2 Measuring Instruments

See list of measuring instruments of this test report.

3.1.3 Test Procedures

1. The EUT was placed 0.4 meter from the conducting wall of the shielding room, and it was kept at least 80 centimeters from any other grounded conducting surface.
2. Connect EUT to the power mains through a line impedance stabilization network (LISN).
3. All the support units are connecting to the other LISN.
4. The LISN provides 50 ohm coupling impedance for the measuring instrument.
5. The FCC states that a 50 ohm, 50 microhenry LISN should be used.
6. Both sides of AC line were checked for maximum conducted interference.
7. The frequency range from 150 kHz to 30 MHz was searched.
8. Set the test-receiver system to Peak Detect Function and specified bandwidth (IF Bandwidth = 9kHz) with Maximum Hold Mode. Then measurement is also conducted by Average Detector and Quasi-Peak Detector Function respectively.

3.1.4 Test setup

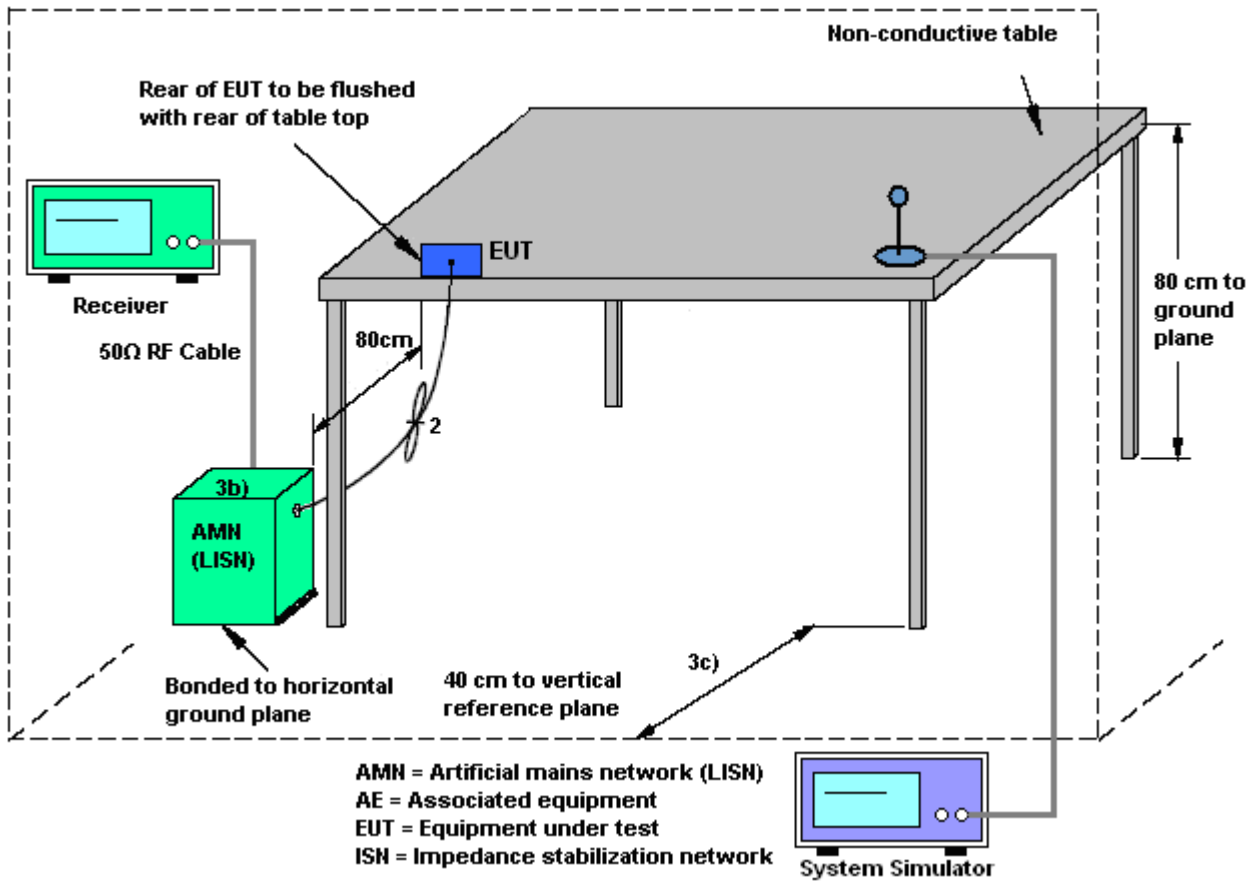

3.1.5 Test Result of AC Conducted Emission

Please refer to Appendix A.



3.2 Field Strength of Fundamental Emissions and Mask Measurement

3.2.1 Limit

Rules and specifications	FCC CFR 47 Part 15 section 15.225			
Description	Compliance with the spectrum mask is tested with RBW set to 9kHz.			
Freq. of Emission (MHz)	Field Strength (μV/m) at 30m	Field Strength (dBμV/m) at 30m	Field Strength (dBμV/m) at 10m	Field Strength (dBμV/m) at 3m
1.705~13.110	30	29.5	48.58	69.5
13.110~13.410	106	40.5	59.58	80.5
13.410~13.553	334	50.5	69.58	90.5
13.553~13.567	15848	84.0	103.08	124.0
13.567~13.710	334	50.5	69.58	90.5
13.710~14.010	106	40.5	59.58	80.5
14.010~30.000	30	29.5	48.58	69.5

3.2.2 Measuring Instruments

See list of measuring instruments of this test report.

3.2.3 Test Procedures

1. Configure the EUT according to ANSI C63.10. The EUT was placed on the top of the turntable 0.8 meter above ground. The phase center of the loop receiving antenna mounted antenna tower was placed 3 meters far away from the turntable.
2. Power on the EUT and all the supporting units. The turntable was rotated by 360 degrees to determine the position of the highest radiation.
3. The height of the receiving antenna was fixed at one meter above ground to find the maximum emissions field strength.
4. For Fundamental emissions, use the receiver to measure QP reading.

5. When the radiated emissions limits are expressed in terms of the average value of the emissions, and pulsed operation is employed, the measurement field strength shall be determined by averaging over one complete pulse train, including blanking intervals, as long as the pulse train does not exceed 0.1 seconds. As an alternative (provided the transmitter operates for longer than 0.1 seconds) or in cases where the pulse train exceeds 0.1 seconds, the measured field strength shall be determined from the average absolute voltage during a 0.1 second interval during which the field strength is at its maximum value.
6. Compliance with the spectrum mask is tested with RBW set to 9kHz.
Note: Emission level (dB μ V/m) = 20 log Emission level (μ V/m).

3.2.4 Test Setup

For radiated emissions below 30MHz

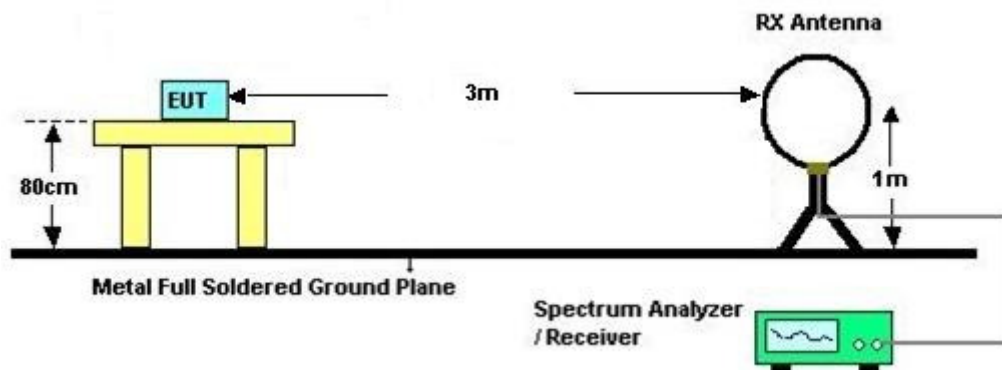

3.2.5 Test Result of Field Strength of Fundamental Emissions and Mask

Please refer to Appendix B.

3.3 Radiated Emissions Measurement

3.3.1 Limit

The field strength of any emissions which appear outside of 13.110 ~14.010MHz band shall not exceed the general radiated emissions limits.

Frequencies (MHz)	Field Strength ($\mu\text{V/m}$)	Measurement Distance (meters)
0.009~0.490	2400/F(kHz)	300
0.490~1.705	24000/F(kHz)	30
1.705~30.0	30	30
30~88	100	3
88~216	150	3
216~960	200	3
Above 960	500	3

3.3.2 Measuring Instruments

See list of measuring instruments of this test report.

3.3.3 Measuring Instrument Setting

The following table is the setting of receiver.

Receiver Parameter	Setting
Attenuation	Auto
Frequency Range: 9kHz~150kHz	RBW 200Hz for QP
Frequency Range: 150kHz~30MHz	RBW 9kHz for QP
Frequency Range: 30MHz~1000MHz	RBW 120kHz for Peak

Note: The emission limits shown in the above table are based on measurements employing a CISPR quasi-peak detector except for the frequency bands 9-90 kHz, 110-490 kHz. Radiated emission limits in these two bands are based on measurements employing an average detector.



3.3.4 Test Procedures

1. Configure the EUT according to ANSI C63.10. The EUT was placed on the top of the turntable 0.8 meter above ground. The phase center of the receiving antenna mounted on the top of a height-variable antenna tower was placed 3 meters far away from the turntable.
1. Power on the EUT and all the supporting units. The turntable was rotated by 360 degrees to determine the position of the highest radiation.
2. The height of the broadband receiving antenna was varied between one meter and four meters above ground to find the maximum emissions field strength of both horizontal and vertical polarization.
3. For each suspected emissions, the antenna tower was scan (from 1 M to 4 M) and then the turntable was rotated (from 0 degree to 360 degrees) to find the maximum reading.
4. Set the test-receiver system to Peak or CISPR quasi-peak Detect Function with specified bandwidth under Maximum Hold Mode.
5. When the radiated emissions limits are expressed in terms of the average value of the emissions, and pulsed operation is employed, the measurement field strength shall be determined by averaging over one complete pulse train, including blanking intervals, as long as the pulse train does not exceed 0.1 seconds. As an alternative (provided the transmitter operates for longer than 0.1 seconds) or in cases where the pulse train exceeds 0.1 seconds, the measured field strength shall be determined from the average absolute voltage during a 0.1 second interval during which the field strength is at its maximum value.
6. In case the emission is lower than 30MHz, loop antenna has to be used for measurement and the recorded data should be QP measured by receiver. Antenna Requirements

3.3.5 Test Setup

For radiated emissions below 30MHz

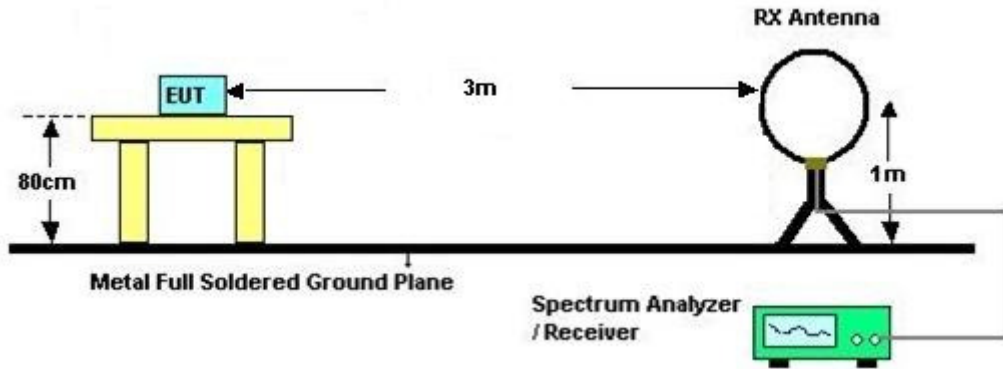

For radiated emissions above 30MHz

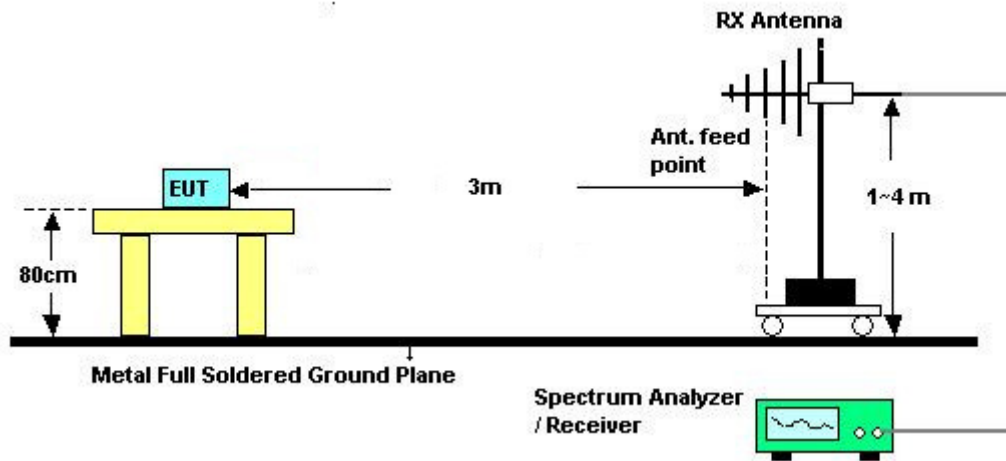

3.3.6 Test Result of Radiated Emissions Measurement

Please refer to Appendix B.



3.4 Antenna Requirements

3.4.1 Standard Applicable

Except for special regulations, the Low-power Radio-frequency Devices must not be equipped with any jacket for installing an antenna with extension cable. An intentional radiator shall be designed to ensure that no antenna other than that furnished by the responsible party shall be used with the device. The use of a permanently attached antenna or of an antenna that uses a unique coupling to the intentional radiator shall be considered sufficient to comply with the provisions of this Section. The manufacturer may design the unit so that the user can replace a broken antenna, but the use of a standard antenna jack or electrical connector is prohibited.

The use of a permanently attached antenna or of an antenna that uses a unique coupling to the intentional radiator shall be considered sufficient to comply with the FCC rule.

3.4.2 Antenna Anti-Replacement Construction

An embedded-in antenna design is used.



4. LIST OF MEASURING EQUIPMENT

Instrument	Manufacturer	Model No.	Serial No.	Characteristics	Calibration Date	Test Date	Due Date	Remark
AC Power Source	ChainTek	APC-1000W	N/A	N/A	N/A	May 04, 2017	N/A	Conduction (CO05-HY)
EMI Test Receiver	Rohde & Schwarz	ESCI 7	100724	9kHz~7GHz	Aug. 30, 2016	May 04, 2017	Aug. 29, 2017	Conduction (CO05-HY)
LISN	Rohde & Schwarz	ENV216	100080	9kHz~30MHz	Nov. 29, 2016	May 04, 2017	Nov. 28, 2017	Conduction (CO05-HY)
Preamplifier	COM-POWER	PA-103A	161241	10MHz-1GHz	Mar. 14, 2017	May 03, 2017	Mar. 13, 2018	Radiation (03CH07-HY)
Bilog Antenna	TESEQ	CBL 6111D&0080 0N1D01N-06	35419&03	30MHz to 1GHz	Jan. 07, 2017	May 03, 2017	Jan. 06, 2018	Radiation (03CH07-HY)
Loop Antenna	Rohde & Schwarz	HFH2-Z2	100315	9 kHz~30 MHz	Sep. 02, 2015	May 03, 2017	Sep. 01, 2017	Radiation (03CH07-HY)
Spectrum Analyzer	Agilent	N9010A	MY5347011 8	10Hz~44GHz	Apr. 17, 2017	May 03, 2017	Apr. 16, 2018	Radiation (03CH07-HY)
Antenna Mast	Max-Full	MFA520BS	N/A	1m~4m	N/A	May 03, 2017	N/A	Radiation (03CH07-HY)
Turn Table	ChainTek	Chaintek 3000	N/A	0~360 Degree	N/A	May 03, 2017	N/A	Radiation (03CH07-HY)
EMI Test Receiver	Keysight	N9038A(MX E)	MY5413008 5	20Hz ~ 8.4GHz	Oct. 26, 2016	May 03, 2017	Oct. 25, 2017	Radiation (03CH07-HY)

Appendix A. Test Results of Conducted Emission Test

Test Mode :	NFC Tx	Test Voltage :	120Vac / 60Hz
Function Type :	GSM850 Idle + Bluetooth Link + WLAN Link + NFC Tx + WPC Back cover + Battery + PMA Charging pad + Adapter		

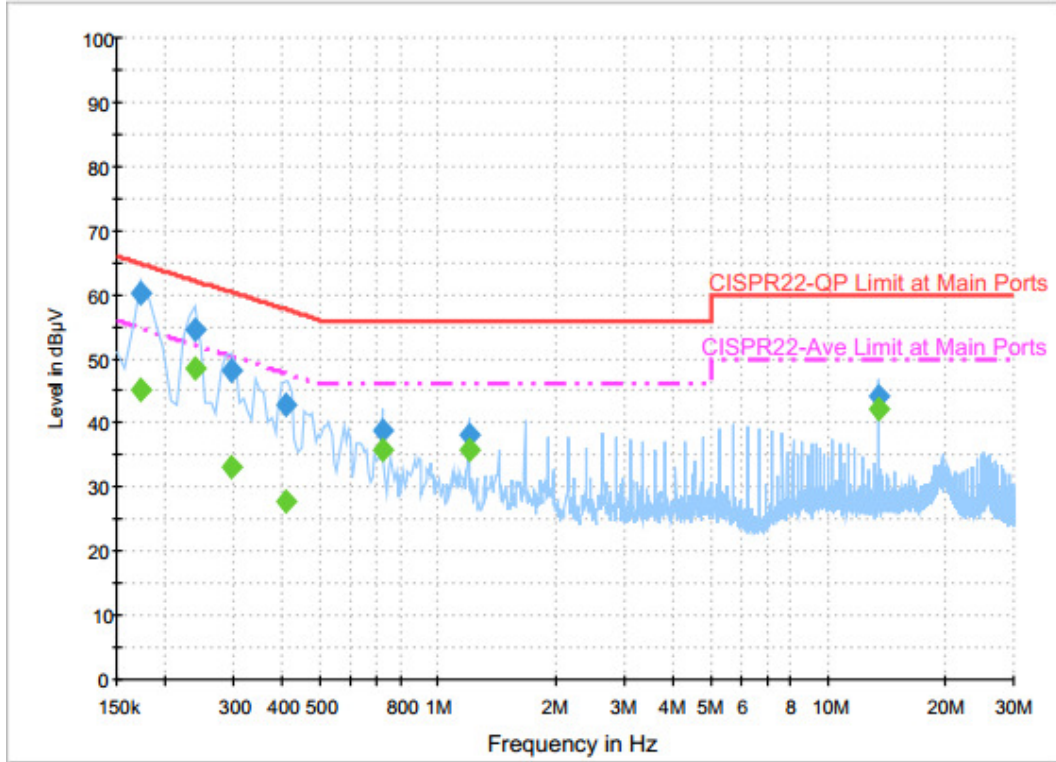

Final Result : Quasi-Peak

Frequency (MHz)	Quasi-Peak (dBµV)	Filter	Line	Corr. (dB)	Margin (dB)	Limit (dBµV)
0.174000	60.1	Off	L1	19.6	4.7	64.8
0.238000	54.6	Off	L1	19.6	7.6	62.2
0.294000	48.3	Off	L1	19.6	12.1	60.4
0.406000	42.8	Off	L1	19.6	14.9	57.7
0.718000	38.8	Off	L1	19.6	17.2	56.0
1.198000	38.1	Off	L1	19.6	17.9	56.0
13.558000	44.0	Off	L1	20.2	16.0	60.0

Final Result : Average

Frequency (MHz)	Average (dBµV)	Filter	Line	Corr. (dB)	Margin (dB)	Limit (dBµV)
0.174000	45.1	Off	L1	19.6	9.7	54.8
0.238000	48.5	Off	L1	19.6	3.7	52.2
0.294000	33.1	Off	L1	19.6	17.3	50.4
0.406000	27.6	Off	L1	19.6	20.1	47.7
0.718000	35.9	Off	L1	19.6	10.1	46.0
1.198000	35.7	Off	L1	19.6	10.3	46.0
13.558000	42.1	Off	L1	20.2	7.9	50.0



Test Mode :	NFC Tx	Test Voltage :	120Vac / 60Hz
Function Type :	GSM850 Idle + Bluetooth Link + WLAN Link + NFC Tx + WPC Back cover + Battery + PMA Charging pad + Adapter		

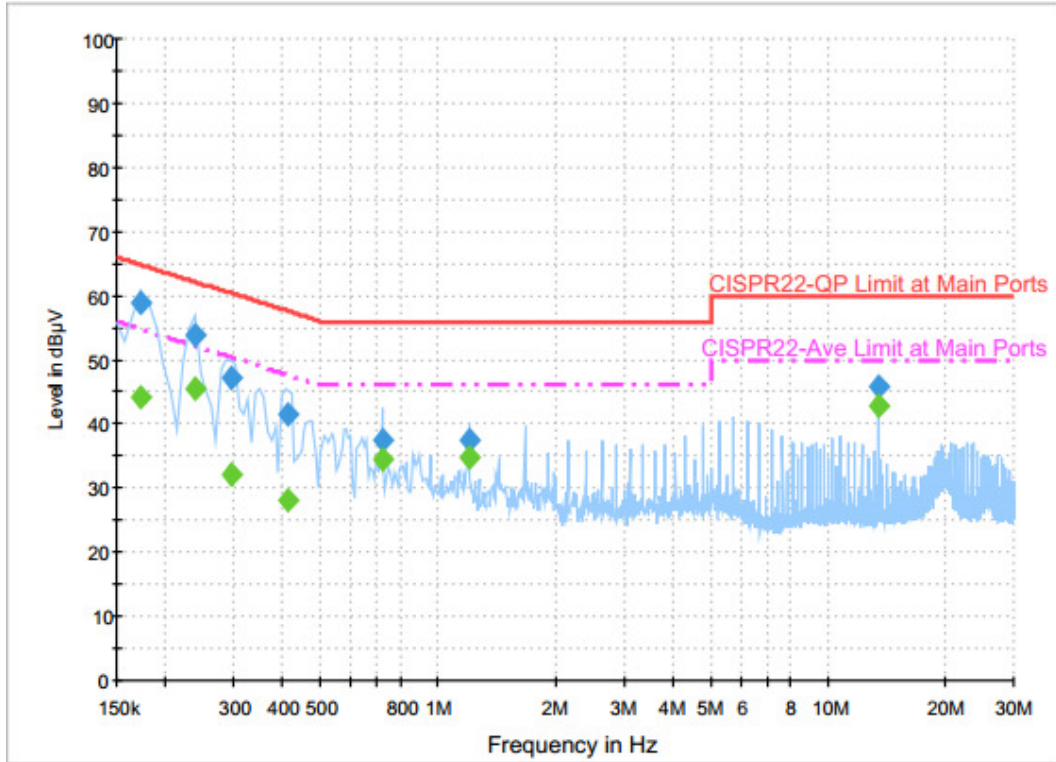

Final Result : Quasi-Peak

Frequency (MHz)	Quasi-Peak (dBµV)	Filter	Line	Corr. (dB)	Margin (dB)	Limit (dBµV)
0.174000	59.0	Off	N	19.5	5.8	64.8
0.238000	53.9	Off	N	19.5	8.3	62.2
0.294000	47.1	Off	N	19.5	13.3	60.4
0.414000	41.5	Off	N	19.5	16.1	57.6
0.718000	37.5	Off	N	19.5	18.5	56.0
1.198000	37.4	Off	N	19.6	18.6	56.0
13.558000	45.8	Off	N	20.3	14.2	60.0

Final Result : Average

Frequency (MHz)	Average (dBµV)	Filter	Line	Corr. (dB)	Margin (dB)	Limit (dBµV)
0.174000	44.1	Off	N	19.5	10.7	54.8
0.238000	45.6	Off	N	19.5	6.6	52.2
0.294000	32.1	Off	N	19.5	18.3	50.4
0.414000	28.1	Off	N	19.5	19.5	47.6
0.718000	34.5	Off	N	19.5	11.5	46.0
1.198000	34.9	Off	N	19.6	11.1	46.0
13.558000	42.7	Off	N	20.3	7.3	50.0



Appendix B. Test Results of Radiated Test Items

B1. Test Result of Field Strength of Fundamental Emissions

<WPC>

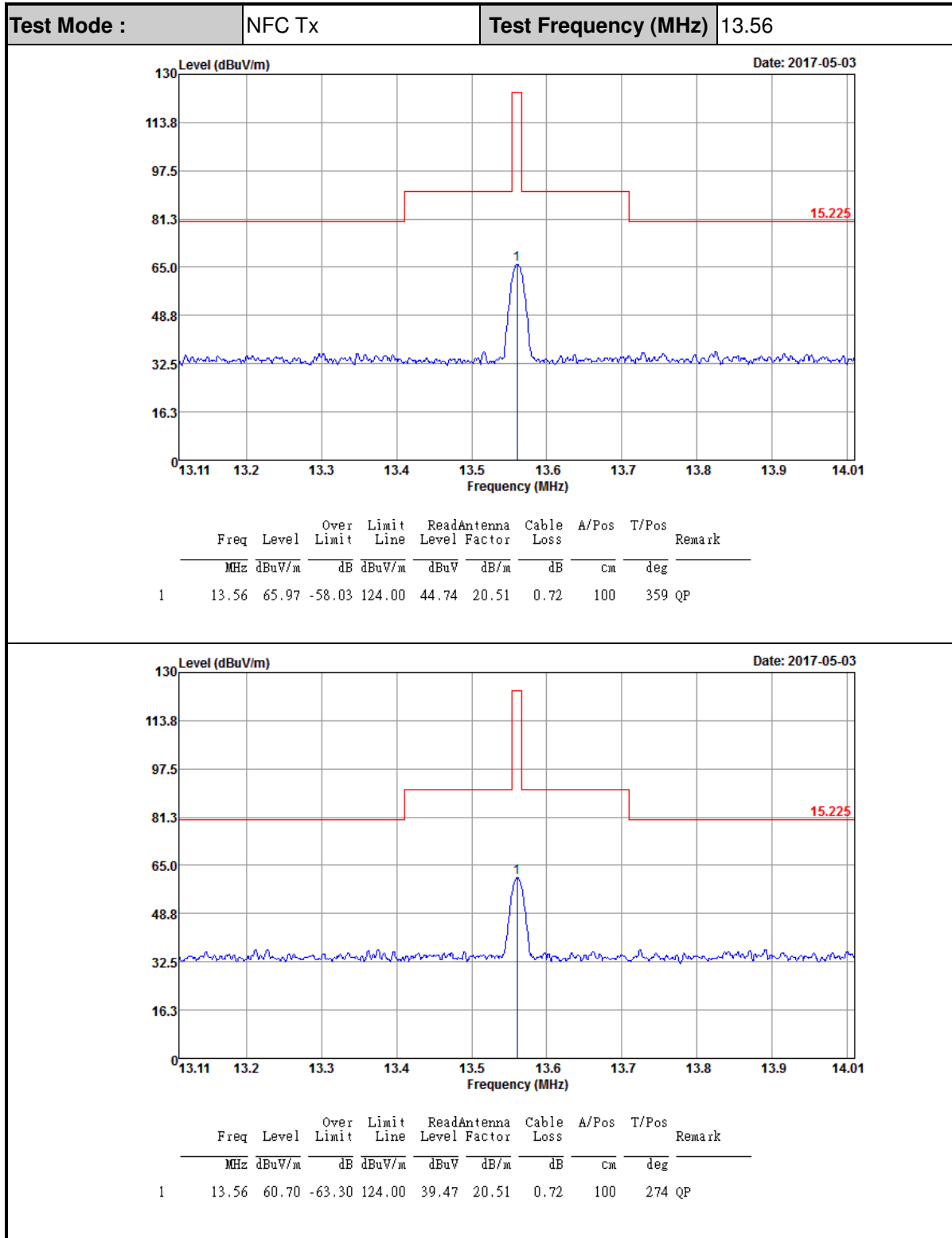



<PMA>

Test Mode :	NFC Tx	Test Frequency (MHz)	13.56
-------------	--------	----------------------	-------

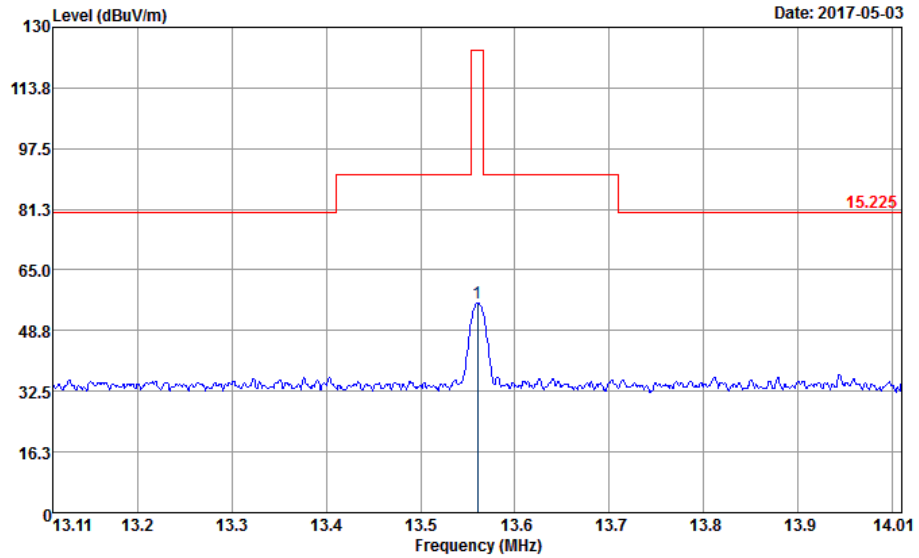

1	13.56	56.28	-67.72	124.00	35.05	20.51	0.72	100	91	QP
---	-------	-------	--------	--------	-------	-------	------	-----	----	----

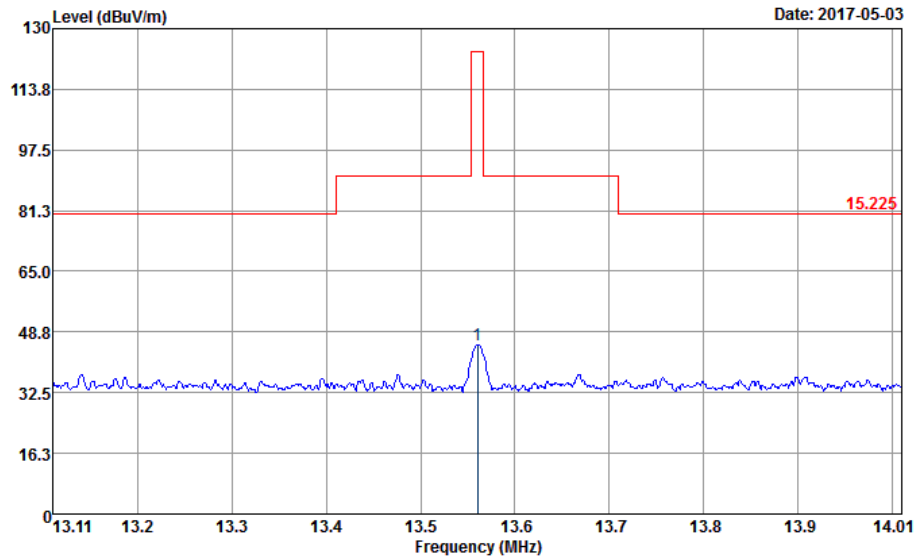

1	13.56	45.29	-78.71	124.00	24.06	20.51	0.72	100	191	QP
---	-------	-------	--------	--------	-------	-------	------	-----	-----	----



B2. Results of Radiated Spurious Emissions (9 kHz~30MHz)

<WPC>

Test Mode :		NFC Tx			Polarization :		Horizontal		
Frequency (MHz)	Level (dBμV/m)	Over Limit (dB)	Limit Line (dBμV/m)	Read Level (dBμV)	Antenna Factor (dB)	Cable Loss (dB)	Ant Pos (cm)	Table Pos (deg)	Remark
0.01538	52.08	-71.79	123.87	28.46	22.9	0.72			Average
0.07503	49.48	-60.62	110.1	29.76	19	0.72			Average
0.09962	50.02	-57.62	107.64	30.5	18.8	0.72			QP
0.14904	44.02	-60.12	104.14	24.53	18.77	0.72			Average
0.2401	60.1	-39.9	100	40.65	18.73	0.72			Average
0.58763	51.75	-20.47	72.22	32.38	18.65	0.72	100	283	QP
12.912	36.86	-32.64	69.5	15.76	20.38	0.72			QP
13.56	65.72	-3.78	69.5	44.49	20.51	0.72			QP
22.597	39.8	-29.7	69.5	16.14	21.95	1.71			QP
26.44	39.32	-30.18	69.5	15.42	22.19	1.71			QP

Test Mode :		NFC Tx			Polarization :		Vertical		
Frequency (MHz)	Level (dBμV/m)	Over Limit (dB)	Limit Line (dBμV/m)	Read Level (dBμV)	Antenna Factor (dB)	Cable Loss (dB)	Ant Pos (cm)	Table Pos (deg)	Remark
0.01538	52.69	-71.18	123.87	29.07	22.9	0.72			Average
0.07593	48.02	-61.98	110	28.3	19	0.72			Average
0.09878	43.44	-64.27	107.71	23.92	18.8	0.72			QP
0.14788	38.45	-65.76	104.21	18.96	18.77	0.72			Average
0.24554	58.1	-41.7	99.8	38.65	18.73	0.72			Average
0.58012	45.79	-26.54	72.33	26.42	18.65	0.72	100	291	QP
9.424	37.16	-32.34	69.5	16.73	19.71	0.72			QP
13.56	60.86	-8.64	69.5	39.63	20.51	0.72			QP
22.705	39.47	-30.03	69.5	15.8	21.96	1.71			QP
28.585	39.48	-30.02	69.5	15.45	22.32	1.71			QP

Note:

1. 13.56 MHz is fundamental signal which can be ignored.
2. The amplitude of spurious emissions which are attenuated by more than 20dB below the permissible value has no need to be reported.
3. Distance extrapolation factor = 40 log (specific distance / test distance) (dB);
4. Limit line = specific limits (dBμV) + distance extrapolation factor.



<PMA>

Test Mode :	NFC Tx	Polarization :	Horizontal
-------------	--------	----------------	------------

Frequency (MHz)	Level (dBμV/m)	Over Limit (dB)	Limit Line (dBμV/m)	Read Level (dBμV)	Antenna Factor (dB)	Cable Loss (dB)	Ant Pos (cm)	Table Pos (deg)	Remark
0.05954	50.09	-62.02	112.11	30.37	19	0.72			Average
0.07449	50.03	-60.13	110.16	30.31	19	0.72			Average
0.10506	35.16	-72.02	107.18	15.64	18.8	0.72			QP
0.11308	33.42	-73.12	106.54	13.9	18.8	0.72			Average
0.4101	49.45	-45.9	95.35	30.08	18.65	0.72			Average
1.354	39.62	-25.35	64.97	20	18.9	0.72	100	77	QP
12.944	37.48	-32.02	69.5	16.37	20.39	0.72			QP
13.56	56.15	-13.35	69.5	34.92	20.51	0.72			QP
20.635	39.6	-29.9	69.5	16.05	21.84	1.71			QP
26.635	39.38	-30.12	69.5	15.47	22.2	1.71			QP

Test Mode :	NFC Tx	Polarization :	Vertical
-------------	--------	----------------	----------

Frequency (MHz)	Level (dBμV/m)	Over Limit (dB)	Limit Line (dBμV/m)	Read Level (dBμV)	Antenna Factor (dB)	Cable Loss (dB)	Ant Pos (cm)	Table Pos (deg)	Remark
0.01538	42.83	-81.04	123.87	19.21	22.9	0.72			Average
0.07374	40.74	-69.51	110.25	21.02	19	0.72			Average
0.10544	33.8	-73.34	107.14	14.28	18.8	0.72			QP
0.11092	35.24	-71.46	106.7	15.72	18.8	0.72			Average
0.22072	41.17	-59.56	100.73	21.71	18.74	0.72			Average
0.52004	36.96	-36.32	73.28	17.62	18.62	0.72			QP
12.72	36.98	-32.52	69.5	15.92	20.34	0.72			QP
13.56	44.48	-25.02	69.5	23.25	20.51	0.72			QP
19.051	39.09	-30.41	69.5	16.76	21.61	0.72			QP
25.765	39.49	-30.01	69.5	15.63	22.15	1.71	100	192	QP

Note:

- 13.56 MHz is fundamental signal which can be ignored.
- The amplitude of spurious emissions which are attenuated by more than 20dB below the permissible value has no need to be reported.
- Distance extrapolation factor = 40 log (specific distance / test distance) (dB);
- Limit line = specific limits (dBμV) + distance extrapolation factor.



B3. Results of Radiated Spurious Emissions (30MHz~1GHz)

<WPC>

Test Mode :	NFC Tx	Polarization :	Horizontal
-------------	--------	----------------	------------

Frequency (MHz)	Level (dBμV/m)	Over Limit (dB)	Limit Line (dBμV/m)	Read Level (dBμV)	Antenna Factor (dB)	Cable Loss (dB)	Preamp Factor (dB)	Ant Pos (cm)	Table Pos (deg)	Remark
31.62	27.55	-12.45	40	32.3	24.92	1.71	31.38			Peak
196.86	33.65	-9.85	43.5	46.53	15.85	2.72	31.45	100	147	Peak
216.03	34.06	-11.94	46	46.41	16.36	2.72	31.43			Peak
853	33.51	-12.49	46	30.14	28.72	5.2	30.55			Peak
913.9	33.8	-12.2	46	29.66	29.33	5.33	30.52			Peak
944	35.97	-10.03	46	31.03	30.06	5.4	30.52			Peak

Test Mode :	NFC Tx	Polarization :	Vertical
-------------	--------	----------------	----------

Frequency (MHz)	Level (dBμV/m)	Over Limit (dB)	Limit Line (dBμV/m)	Read Level (dBμV)	Antenna Factor (dB)	Cable Loss (dB)	Preamp Factor (dB)	Ant Pos (cm)	Table Pos (deg)	Remark
71.85	28.54	-11.46	40	45.1	12.92	2.11	31.59	100	223	Peak
187.14	29.76	-13.74	43.5	43.03	15.47	2.72	31.46			Peak
235.2	32.01	-13.99	46	42.7	17.68	3.03	31.4			Peak
861.4	32.93	-13.07	46	29.44	28.77	5.27	30.55			Peak
928.6	34.22	-11.78	46	29.73	29.68	5.33	30.52			Peak
946.8	34.48	-11.52	46	29.47	30.13	5.4	30.52			Peak

Note:

1. The amplitude of spurious emissions which are attenuated by more than 20dB below the permissible value has no need to be reported.
2. Emission level (dBμV/m) = 20 log Emission level (μV/m).
3. Corrected Reading: Antenna Factor + Cable Loss + Read Level - Preamp Factor= Level.



<PMA>

Test Mode :	NFC Tx	Polarization :	Horizontal
-------------	--------	----------------	------------

Frequency (MHz)	Level (dBμV/m)	Over Limit (dB)	Limit Line (dBμV/m)	Read Level (dBμV)	Antenna Factor (dB)	Cable Loss (dB)	Preamp Factor (dB)	Ant Pos (cm)	Table Pos (deg)	Remark
30.27	28.83	-11.17	40	32.47	26	1.71	31.35	100	127	Peak
80.49	27.87	-12.13	40	43.44	13.9	2.11	31.58			Peak
159.06	31.39	-12.11	43.5	43.19	17.07	2.62	31.49			Peak
830.6	32.4	-13.6	46	29.46	28.31	5.2	30.57			Peak
885.9	33.48	-12.52	46	29.83	28.91	5.27	30.53			Peak
951.7	34.04	-11.96	46	28.95	30.2	5.4	30.51			Peak

Test Mode :	NFC Tx	Polarization :	Vertical
-------------	--------	----------------	----------

Frequency (MHz)	Level (dBμV/m)	Over Limit (dB)	Limit Line (dBμV/m)	Read Level (dBμV)	Antenna Factor (dB)	Cable Loss (dB)	Preamp Factor (dB)	Ant Pos (cm)	Table Pos (deg)	Remark
57.81	35.38	-4.62	40	52.65	12.62	1.71	31.6	100	224	Peak
71.58	30.68	-9.32	40	47.24	12.92	2.11	31.59			Peak
155.55	27.89	-15.61	43.5	39.42	17.35	2.62	31.5			Peak
862.8	32.85	-13.15	46	29.35	28.78	5.27	30.55			Peak
911.1	34.01	-11.99	46	29.94	29.26	5.33	30.52			Peak
954.5	34.39	-11.61	46	29.29	30.21	5.4	30.51			Peak

Note:

1. The amplitude of spurious emissions which are attenuated by more than 20dB below the permissible value has no need to be reported.
2. Emission level (dBμV/m) = 20 log Emission level (μV/m).
3. Corrected Reading: Antenna Factor + Cable Loss + Read Level - Preamp Factor= Level.