



FCC RF Test Report

APPLICANT : Motorola Mobility LLC.
EQUIPMENT : Mobile Cellular Phone
BRAND NAME : Motorola
MODEL NAME : 9397
FCC ID : IHDT56VD5
STANDARD : FCC Part 15 Subpart C §15.225
CLASSIFICATION : (DXX) Low Power Communication Device Transmitter

The testing was completed on May 10, 2016. We, SPORTON INTERNATIONAL INC., would like to declare that the tested sample has been evaluated in accordance with the test procedures and has been in compliance with the applicable technical standards.

The test results in this report apply exclusively to the tested model / sample. Without written approval of SPORTON INTERNATIONAL INC., the test report shall not be reproduced except in full.

Reviewed by: Joseph Lin / Supervisor

Approved by: Jones Tsai / Manager



SPORTON INTERNATIONAL INC.

No. 52, Hwa Ya 1st Rd., Hwa Ya Technology Park, Kwei-Shan District, Tao Yuan City, Taiwan, R.O.C.



Table of Contents

SUMMARY OF THE TEST RESULT4
1. GENERAL INFORMATION.....5
1.1 Applicant 5
1.2 Manufacturer..... 5
1.3 Feature of Equipment Under Test 5
1.4 Product Details..... 6
1.5 Modification of EUT..... 6
1.6 Testing Location 7
1.7 Applicable Standards 7
1.8 Test Modes..... 8
1.9 Test Configurations..... 9
1.10 Table for Supporting Units 10
2. CONDUCTED EMISSION TEST.....11
2.1 Measuring Instruments 11
2.2 Test setup 11
2.3 Test Result of Conducted Emission Test..... 11
2.4 AC Power Line Conducted Emissions Measurement 12
3. CONDUCTED TEST ITEMS13
3.1 Measuring Instruments 13
3.2 Test Setup 13
3.3 Test Result of Conducted Test Items..... 13
3.4 20dB and 99% OBW Spectrum Bandwidth Measurement..... 14
3.5 Frequency Stability Measurement 14
4. RADIATED TEST ITEMS.....15
4.1 Measuring Instruments 15
4.2 Test Setup 15
4.3 Test Result of Radiated Test Items 15
4.4 Field Strength of Fundamental Emissions and Mask Measurement 16
4.5 Radiated Emissions Measurement 17
5. LIST OF MEASURING EQUIPMENT19
APPENDIX A. TEST RESULTS OF CONDUCTED EMISSION TEST
APPENDIX B. TEST RESULTS OF CONDUCTED TEST ITEMS
B.1. Test Result of 20dB Spectrum Bandwidth
B.2 Test Result of Frequency Stability
APPENDIX C. TEST RESULTS OF RADIATED TEST ITEMS
C.1 Test Result of Field Strength of Fundamental Emissions
C.2 Results of Radiated Emissions (9 kHz~30MHz)
C.3 Results of Radiated Emissions (30MHz~1GHz)



SUMMARY OF THE TEST RESULT

Applied Standard: 47 CFR FCC Part 15 Subpart C				
Part	FCC Rule	Description of Test	Result	Under Limit
3.1	15.207	AC Power Line Conducted Emissions	Complies	4.80 dB at 13.558MHz
3.2	15.225(a)(b)(c)	Field Strength of Fundamental Emissions	Complies	60.74 dB at 13.56 MHz
3.3	2.1049	20dB Spectrum Bandwidth	Complies	-
3.3	-	99% OBW Spectrum Bandwidth	Complies	-
3.4	15.225(d) 15.209	Radiated Emissions	Complies	3.79 dB at 40.800 MHz
3.5	15.225(e)	Frequency Stability	Complies	-
3.6	15.203	Antenna Requirements	Complies	-

Test Items	Uncertainty	Remark
AC Power Line Conducted Emissions	±2.26dB	Confidence levels of 95%
Radiated Emissions (30MHz~1000MHz)	±4.80dB	Confidence levels of 95%



1. GENERAL INFORMATION

1.1 Applicant

Motorola Mobility LLC.

222 W. Merchandise Mart Plaza, Chicago IL 60654 USA

1.2 Manufacturer

Motorola Mobility LLC.

222 W. Merchandise Mart Plaza, Chicago IL 60654 USA

1.3 Feature of Equipment Under Test

Product Feature	
Equipment	Mobile Cellular Phone
Brand Name	Motorola
FCC Model Name	9397
FCC ID	IHDT56VD5
IMEI Code	354145070000075
EUT supports Radios application	GSM/EGPRS/WCDMA/HSPA/LTE/NFC WLAN 11b/g/n HT20 Bluetooth v3.0 EDR Bluetooth v4.1 - LE
HW Version	DVT2-A
SW Version	fastboot_harpia_oem_userdebug_6.0.1_MPI24.223_2173_i ntcfg-test-keys_oem.tar.gz
EUT Stage	Identical Prototype

Accessory List	
AC Adapter 1	Brand Name : Motorola
	Model Name : SPN5944A
AC Adapter 2	Brand Name : Motorola
	Model Name : SPN5816A (SPN5816C)
Battery 1	Brand Name : Motorola
	Model Name : SNN5976A
Battery 2	Brand Name : Motorola
	Model Name : SNN5977A
Earphone	Brand Name : Motorola
	Model Name : SJYN1181B
USB Cable	Brand Name : Motorola
	Model Name : SKN6462A



1.4 Product Details

Items	Description
Tx/Rx Frequency Range	13.553 ~ 13.567MHz
Channel Number	1
20dBW	2.64 KHz
99%OBW	2.24 KHz
Antenna Type	Loop Antenna
Type of Modulation	ASK

Remark: The above EUT's information was declared by manufacturer. Please refer to the specifications or user's manual for more detailed description.

1.5 Modification of EUT

No modifications are made to the EUT during all test items.

1.6 Testing Location

Sporton Lab is accredited to ISO 17025 by Taiwan Accreditation Foundation (TAF code : 1190) and the FCC designation No. TW1022 under the FCC 2.948(e) by Mutual Recognition Agreement (MRA) in FCC Test.

Test Site	SPORTON INTERNATIONAL INC.	
Test Site Location	No. 52, Hwa Ya 1 st Rd., Hwa Ya Technology Park, Kwei-Shan District, Tao Yuan City, Taiwan, R.O.C. TEL: +886-3-3273456 / FAX: +886-3-3284978	
Test Site No.	Sporton Site No.	
	TH03-HY	CO05-HY
Test Engineer	Tommy Lee	Arthur Hsieh
Temperature	22~24°C	23~24°C
Relative Humidity	53~55%	51~52%

Note: The test site complies with ANSI C63.4 2014 requirement.

Test Site	SPORTON INTERNATIONAL INC.	
Test Site Location	No. 52, Hwa Ya 1 st Rd., Hwa Ya Technology Park, Kwei-Shan District, Tao Yuan City, Taiwan, R.O.C. TEL: +886-3-3273456 / FAX: +886-3-3284978	
Test Site No.	Sporton Site No.	
	03CH13-HY	
Test Engineer	Kyle Jhuang	
Temperature	23~24°C	
Relative Humidity	43~44%	

Note: The test site complies with ANSI C63.4 2014 requirement.

1.7 Applicable Standards

According to the specifications of the manufacturer, the EUT must comply with the requirements of the following standards:

- ♦ FCC Part 15 Subpart C §15.225
- ♦ ANSI C63.10-2013



1.8 Test Modes

Investigation has been done on all the possible configurations for searching the worst cases. The following table is a list of the test modes shown in this test report.

Test Items	
AC Power Line Conducted Emissions	Field Strength of Fundamental Emissions
20dB Spectrum Bandwidth	Frequency Stability
Radiated Emissions 9kHz~30MHz	Radiated Emissions 30MHz~1GHz
Note: 1. The EUT was programmed to be in continuously transmitting mode. 2. The ancillary equipment, NFC card, is used to make the EUT (NFC) continuously transmit at 13.56MHz and is placed around 3 cm gap to the EUT.	

1.9 Test Configurations

<AC Conducted Emissions>

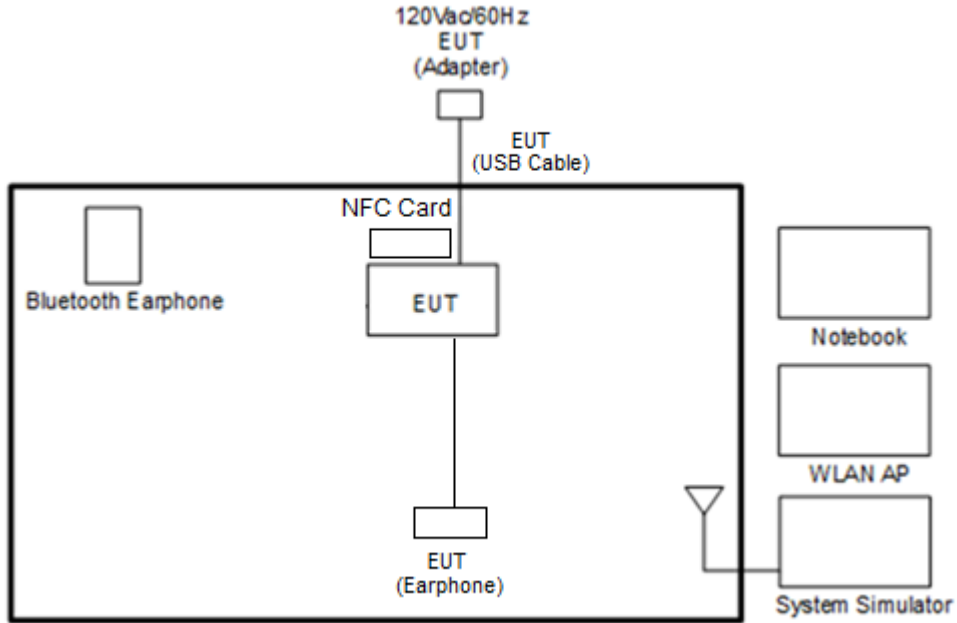

< For Fundamental Emissions and Mask and Radiated Emissions Measurement >

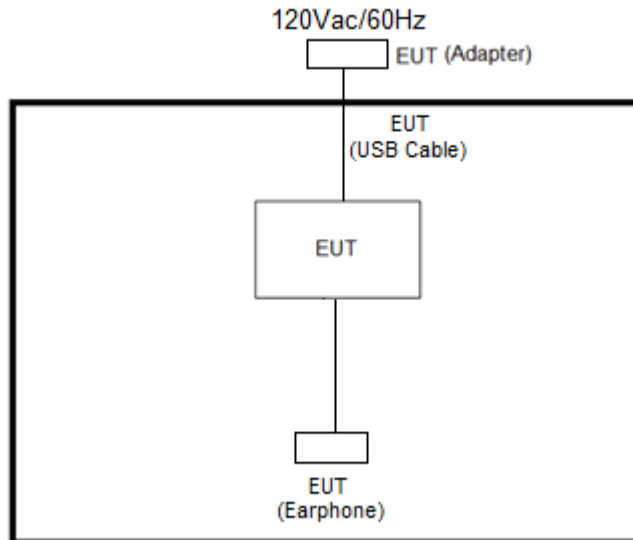



1.10 Table for Supporting Units

Support Unit	Manufacturer	Model	FCC ID
System Simulator	Anritsu	MT8820C	N/A
WLAN AP	D-Link	DIR-628	KA2DIR628A2
Bluetooth Earphone	Sony Ericsson	MW600	PY70DA2029
Notebook	DELL	Latitude E6320	FCC DoC/ Contains FCC ID: QDS-BRCM1054
SD Card	SanDisk	MicroSD HC	FCC DoC
NFC Card	Metro Taipei	Easy Card	N/A

2. CONDUCTED EMISSION TEST

2.1 Measuring Instruments

See list of measuring instruments of this test report.

2.2 Test setup

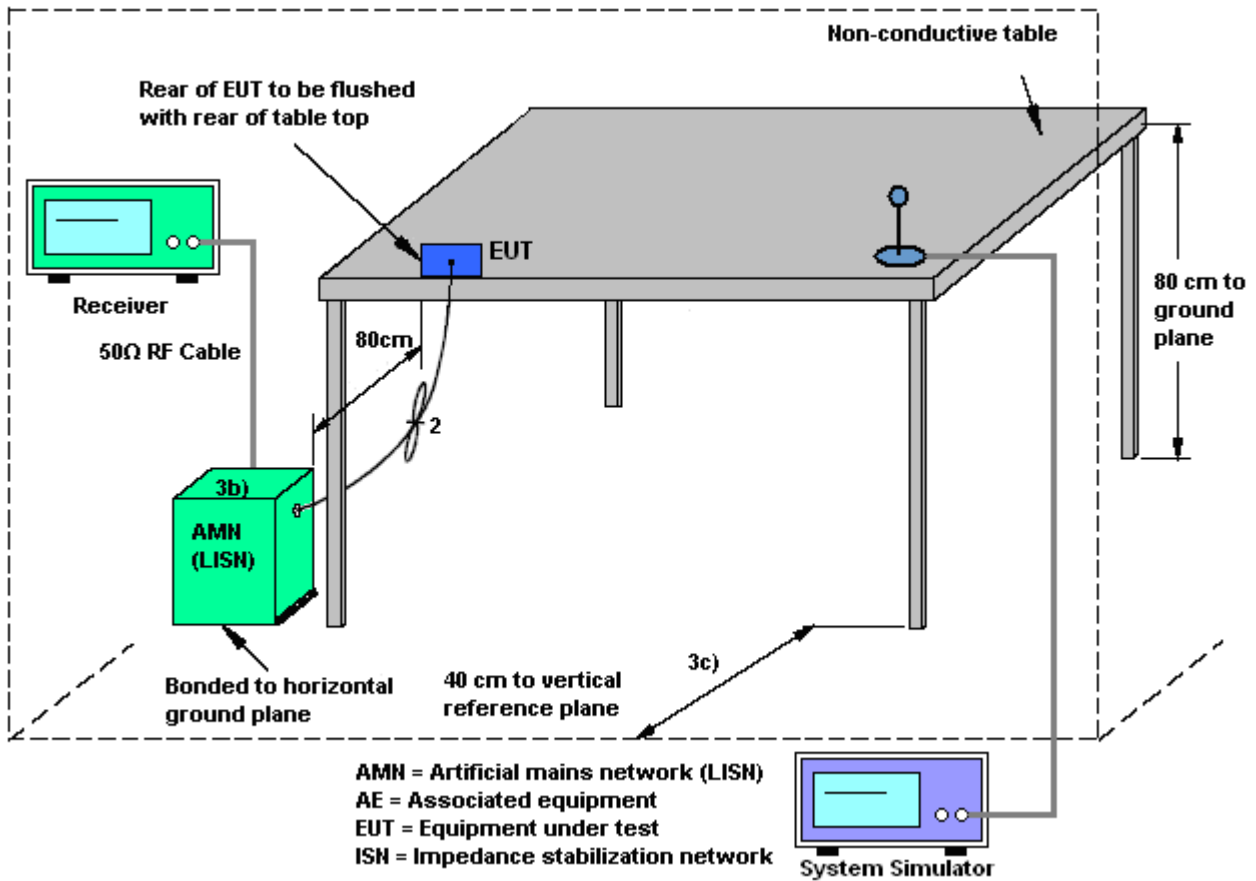

2.3 Test Result of Conducted Emission Test

Please refer to Appendix B.



2.4 AC Power Line Conducted Emissions Measurement

2.4.1 Limit

For equipment that is designed to be connected to the public utility (AC) power line, the radio frequency voltage that is conducted back onto the AC power line on any frequency or frequencies within the band 150 kHz to 30 MHz shall not exceed the limits in the following table.

Frequency of Emission (MHz)	Conducted Limit (dB μ V)	
	Quasi-Peak	Average
0.15-0.5	66 to 56*	56 to 46*
0.5-5	56	46
5-30	60	50

*Decreases with the logarithm of the frequency.

2.4.2 Test Procedures

1. The EUT was placed 0.4 meter from the conducting wall of the shielding room, and it was kept at least 80 centimeters from any other grounded conducting surface.
2. Connect EUT to the power mains through a line impedance stabilization network (LISN).
3. All the support units are connecting to the other LISN.
4. The LISN provides 50 ohm coupling impedance for the measuring instrument.
5. The FCC states that a 50 ohm, 50 microhenry LISN should be used.
6. Both sides of AC line were checked for maximum conducted interference.
7. The frequency range from 150 kHz to 30 MHz was searched.
8. Set the test-receiver system to Peak Detect Function and specified bandwidth (IF Bandwidth = 9kHz) with Maximum Hold Mode. Then measurement is also conducted by Average Detector and Quasi-Peak Detector Function respectively.

3. CONDUCTED TEST ITEMS

3.1 Measuring Instruments

See list of measuring instruments of this test report.

3.2 Test Setup

3.2.1 20dB and 99% OBW Spectrum Bandwidth

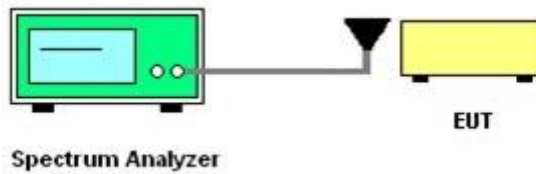

3.2.2 Frequency Stability

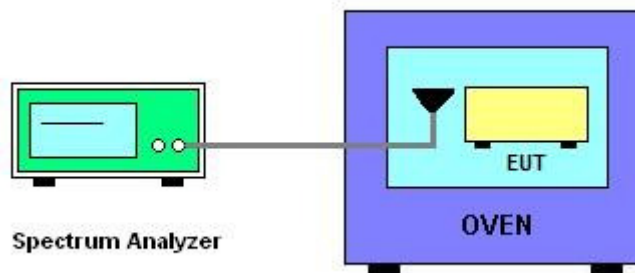

3.3 Test Result of Conducted Test Items

Please refer to Appendix C.



3.4 20dB and 99% OBW Spectrum Bandwidth Measurement

3.4.1 Limit

Intentional radiators must be designed to ensure that the 20dB and 99% emission bandwidth in the specific band 13.553~13.567MHz.

3.4.2 Test Procedures

1. The spectrum analyzer connected via a receive antenna placed near the EUT in peak Max hold mode.
2. The resolution bandwidth of 1 kHz and the video bandwidth of 3 kHz were used.
3. Measured the spectrum width with power higher than 20dB below carrier.
4. Measured the 99% OBW.

3.5 Frequency Stability Measurement

3.5.1 Limit

The frequency tolerance of the carrier signal shall be maintained within +/- 0.01% (100ppm) of the operating frequency over a temperature variation of -20 degrees to +50 degrees C at normal supply voltage, and for a variation in the primary supply voltage from 85% to 115% of the rated supply voltage at a temperature of 20 degrees C. For battery operated equipment, the equipment tests shall be performed using a new battery.

3.5.2 Test Procedures

1. The spectrum analyzer connected via a receive antenna placed near the EUT.
2. EUT have transmitted signal and fixed channelize.
3. Set the spectrum analyzer span to view the entire emissions bandwidth.
4. Set RBW = 1 kHz, VBW = 3 kHz with peak detector and maxhold settings.
5. The f_c is declaring of channel frequency. Then the frequency error formula is $(f_c - f) / f_c \times 10^6$ ppm and the limit is less than ± 100 ppm.
6. Extreme temperature rule is -20°C~50°C.

4. RADIATED TEST ITEMS

4.1 Measuring Instruments

See list of measuring instruments of this test report.

4.2 Test Setup

4.2.1 For radiated emissions below 30MHz

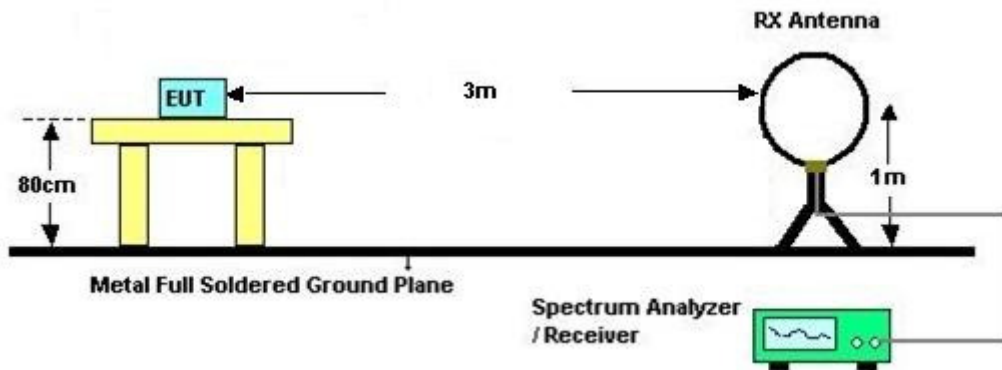

4.2.2 For radiated emissions above 30MHz

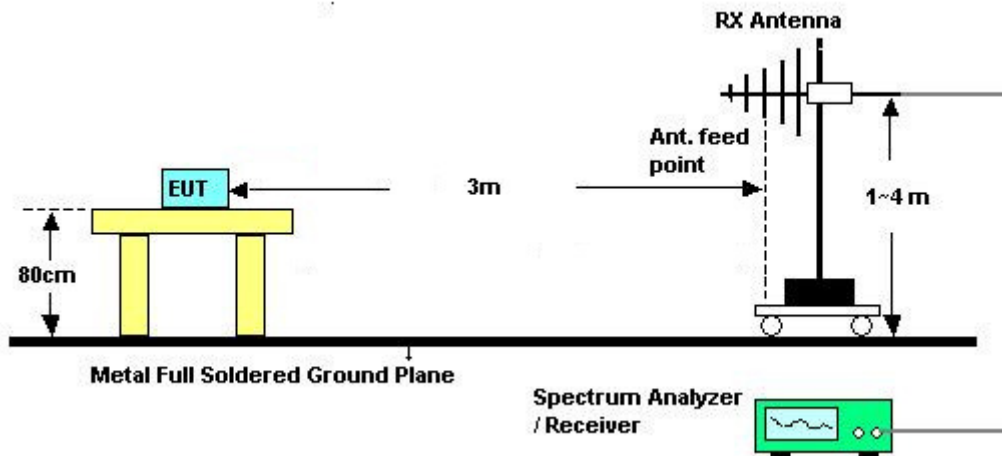

4.3 Test Result of Radiated Test Items

Please refer to Appendix D.



4.4 Field Strength of Fundamental Emissions and Mask Measurement

4.4.1 Limit

Rules and specifications	FCC CFR 47 Part 15 section 15.225 IC RSS-210 A2.6			
	Description			
Description	Compliance with the spectrum mask is tested with RBW set to 9kHz.			
Freq. of Emission (MHz)	Field Strength (µV/m) at 30m	Field Strength (dBµV/m) at 30m	Field Strength (dBµV/m) at 10m	Field Strength (dBµV/m) at 3m
1.705~13.110	30	29.5	48.58	69.5
13.110~13.410	106	40.5	59.58	80.5
13.410~13.553	334	50.5	69.58	90.5
13.553~13.567	15848	84.0	103.08	124.0
13.567~13.710	334	50.5	69.58	90.5
13.710~14.010	106	40.5	59.58	80.5
14.010~30.000	30	29.5	48.58	69.5

4.4.2 Test Procedures

1. Configure the EUT according to ANSI C63.10. The EUT was placed on the top of the turntable 0.8 meter above ground. The phase center of the loop receiving antenna mounted antenna tower was placed 3 meters far away from the turntable.
2. Power on the EUT and all the supporting units. The turntable was rotated by 360 degrees to determine the position of the highest radiation.
3. The height of the receiving antenna was fixed at one meter above ground to find the maximum emissions field strength.
4. For Fundamental emissions, use the receiver to measure QP reading.
5. When the radiated emissions limits are expressed in terms of the average value of the emissions, and pulsed operation is employed, the measurement field strength shall be determined by averaging over one complete pulse train, including blanking intervals, as long as the pulse train does not exceed 0.1 seconds. As an alternative (provided the transmitter operates for longer than 0.1 seconds) or in cases where the pulse train exceeds 0.1 seconds, the measured field strength shall be determined from the average absolute voltage during a 0.1 second interval during which the field strength is at its maximum value.
6. Compliance with the spectrum mask is tested with RBW set to 9kHz.

Note: Emission level (dBµV/m) = 20 log Emission level (µV/m).



4.5 Radiated Emissions Measurement

4.5.1 Limit

The field strength of any emissions which appear outside of 13.110 ~14.010MHz band shall not exceed the general radiated emissions limits.

Frequencies (MHz)	Field Strength (µV/m)	Measurement Distance (meters)
0.009~0.490	2400/F(kHz)	300
0.490~1.705	24000/F(kHz)	30
1.705~30.0	30	30
30~88	100	3
88~216	150	3
216~960	200	3
Above 960	500	3

4.5.2 Measuring Instrument Setting

The following table is the setting of receiver.

Receiver Parameter	Setting
Attenuation	Auto
Frequency Range: 9kHz~150kHz	RBW 200Hz for QP
Frequency Range: 150kHz~30MHz	RBW 9kHz for QP
Frequency Range: 30MHz~1000MHz	RBW 120kHz for Peak

Note: The emission limits shown in the above table are based on measurements employing a CISPR quasi-peak detector except for the frequency bands 9-90 kHz, 110-490 kHz. Radiated emission limits in these two bands are based on measurements employing an average detector.



4.5.3 Test Procedures

1. Configure the EUT according to ANSI C63.10. The EUT was placed on the top of the turntable 0.8 meter above ground. The phase center of the receiving antenna mounted on the top of a height-variable antenna tower was placed 3 meters far away from the turntable.
1. Power on the EUT and all the supporting units. The turntable was rotated by 360 degrees to determine the position of the highest radiation.
2. The height of the broadband receiving antenna was varied between one meter and four meters above ground to find the maximum emissions field strength of both horizontal and vertical polarization.
3. For each suspected emissions, the antenna tower was scan (from 1 M to 4 M) and then the turntable was rotated (from 0 degree to 360 degrees) to find the maximum reading.
4. Set the test-receiver system to Peak or CISPR quasi-peak Detect Function with specified bandwidth under Maximum Hold Mode.
5. When the radiated emissions limits are expressed in terms of the average value of the emissions, and pulsed operation is employed, the measurement field strength shall be determined by averaging over one complete pulse train, including blanking intervals, as long as the pulse train does not exceed 0.1 seconds. As an alternative (provided the transmitter operates for longer than 0.1 seconds) or in cases where the pulse train exceeds 0.1 seconds, the measured field strength shall be determined from the average absolute voltage during a 0.1 second interval during which the field strength is at its maximum value.
6. In case the emission is lower than 30MHz, loop antenna has to be used for measurement and the recorded data should be QP measured by receiver. Antenna Requirements

4.5.4 Limit

Except for special regulations, the Low-power Radio-frequency Devices must not be equipped with any jacket for installing an antenna with extension cable. An intentional radiator shall be designed to ensure that no antenna other than that furnished by the responsible party shall be used with the device. The use of a permanently attached antenna or of an antenna that uses a unique coupling to the intentional radiator shall be considered sufficient to comply with the provisions of this Section. The manufacturer may design the unit so that the user can replace a broken antenna, but the use of a standard antenna jack or electrical connector is prohibited.

4.5.5 Antenna Anti-Replacement Construction

An embedded-in antenna design is used.



5. LIST OF MEASURING EQUIPMENT

Instrument	Manufacturer	Model No.	Serial No.	Characteristics	Calibration Date	Test Date	Due Date	Remark
AC Power Source	AC POWER	AFC-500W	F104070011	50Hz~60Hz	Dec. 02, 2015	May 27, 2016	Dec. 01, 2016	Conducted (TH03-HY)
Spectrum Analyzer	Rohde & Schwarz	FSP30	101329	9kHz~30GHz	Jun. 24, 2015	May 27, 2016	Jun. 23, 2016	Conducted (TH03-HY)
Temperature Chamber	ESPEC	SU-641	92013721	-30°C ~70°C	Nov. 20, 2015	May 27, 2016	Nov. 19, 2016	Conducted (TH03-HY)
AC Power Source	ChainTek	APC-1000W	N/A	N/A	N/A	May 25, 2016	N/A	Conduction (CO05-HY)
EMI Test Receiver	Rohde & Schwarz	ESCI 7	100724	9kHz~7GHz	Aug. 26, 2015	May 25, 2016	Aug. 25, 2016	Conduction (CO05-HY)
LISN	Rohde & Schwarz	ENV216	100080	9kHz~30MHz	Dec. 02, 2015	May 25, 2016	Dec. 01, 2016	Conduction (CO05-HY)
Loop Antenna	Rohde & Schwarz	HFH2-Z2	100315	9 kHz~30 MHz	Sep. 02, 2015	Jun. 02, 2016	Sep. 01, 2016	Radiation (03CH13-HY)
Amplifier	Sonoma-Instrument	310 N	187282	10MHz~1GHz	Dec. 31, 2015	Jun. 02, 2016	Dec. 30, 2016	Radiation (03CH13-HY)
Bilog Antenna	TESEQ	CBL 6111D	40103	30MHz to 1GHz	Jan. 13, 2016	Jun. 02, 2016	Jan. 12, 2017	Radiation (03CH13-HY)
EMI Test Receiver	Keysight	N9038A (MXE)	MY55420170	N/A	Mar. 10, 2016	Jun. 02, 2016	Mar. 09, 2017	Radiation (03CH13-HY)
Spectrum Analyzer	Keysight	N9010A	MY55370526	N/A	Mar. 14, 2016	Jun. 02, 2016	Mar. 13, 2017	Radiation (03CH13-HY)

Appendix A. Test Results of Conducted Emission Test

Test Mode :	NFC Tx	Test Voltage :	120Vac / 60Hz
Function Type :	GSM850 Idle + Bluetooth Link + WLAN Link + Earphone + Battery 1 + USB Cable (Charging from Adapter 1) + NFC Tx		

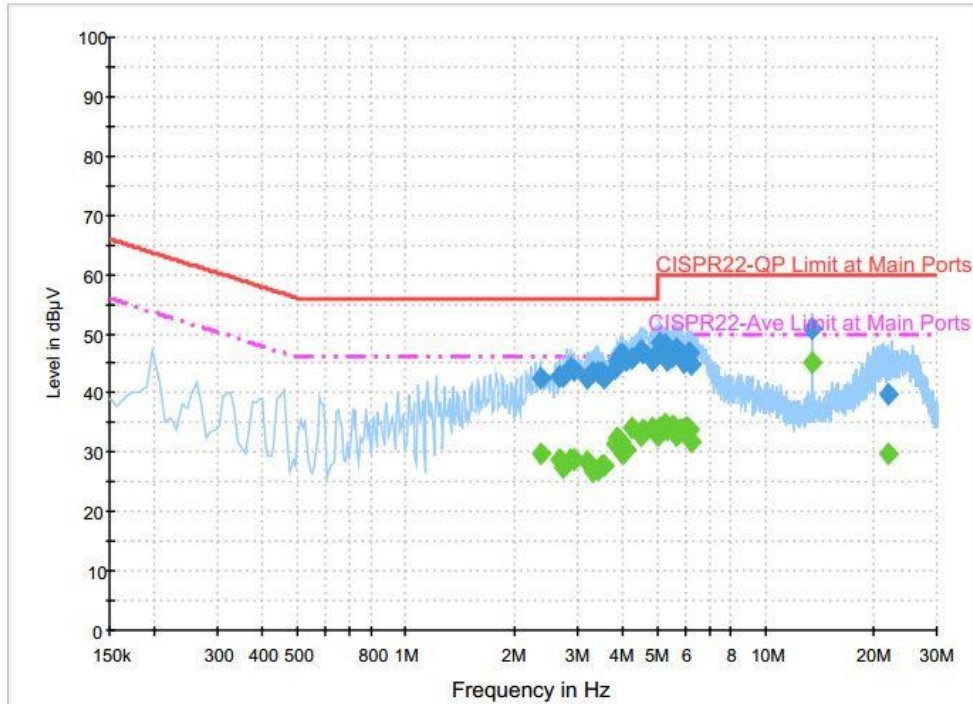

Final Result : Quasi-Peak

Frequency (MHz)	Quasi-Peak (dBµV)	Filter	Line	Corr. (dB)	Margin (dB)	Limit (dBµV)
2.366000	42.4	Off	L1	19.6	13.6	56.0
2.678000	43.0	Off	L1	19.7	13.0	56.0
2.734000	42.9	Off	L1	19.7	13.1	56.0
2.870000	44.2	Off	L1	19.7	11.8	56.0
2.942000	43.9	Off	L1	19.7	12.1	56.0
3.190000	42.4	Off	L1	19.7	13.6	56.0
3.310000	43.4	Off	L1	19.7	12.6	56.0
3.446000	43.5	Off	L1	19.7	12.5	56.0
3.518000	43.6	Off	L1	19.8	12.4	56.0
3.574000	42.3	Off	L1	19.8	13.7	56.0
3.814000	44.3	Off	L1	19.8	11.7	56.0
3.878000	45.5	Off	L1	19.8	10.5	56.0
3.950000	46.3	Off	L1	19.8	9.7	56.0
4.030000	46.6	Off	L1	19.8	9.4	56.0
4.094000	45.6	Off	L1	19.8	10.4	56.0
4.278000	45.9	Off	L1	19.8	10.1	56.0
4.542000	47.2	Off	L1	19.8	8.8	56.0
4.598000	47.0	Off	L1	19.8	9.0	56.0
4.862000	45.4	Off	L1	19.8	10.6	56.0



Test Mode :	NFC Tx	Test Voltage :	120Vac / 60Hz
Function Type :	GSM850 Idle + Bluetooth Link + WLAN Link + Earphone + Battery 1 + USB Cable (Charging from Adapter 1) + NFC Tx		

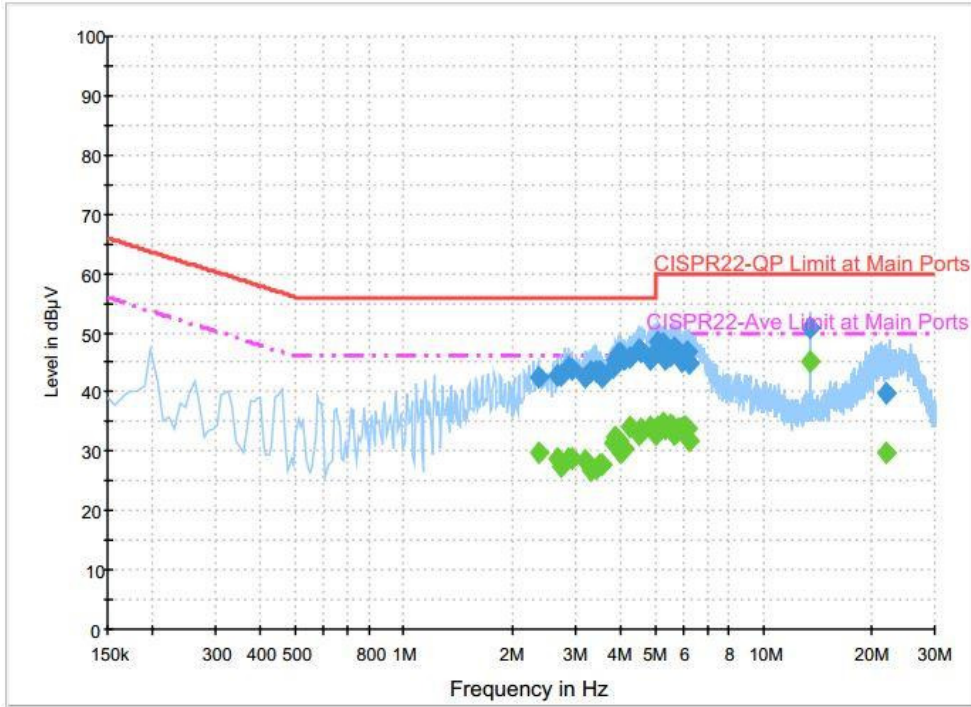

Final Result : Quasi-Peak

Frequency (MHz)	Quasi-Peak (dBµV)	Filter	Line	Corr. (dB)	Margin (dB)	Limit (dBµV)
5.038000	46.8	Off	L1	19.8	13.2	60.0
5.118000	48.3	Off	L1	19.8	11.7	60.0
5.262000	48.3	Off	L1	19.9	11.7	60.0
5.366000	45.4	Off	L1	19.9	14.6	60.0
5.510000	46.2	Off	L1	19.9	13.8	60.0
5.598000	47.1	Off	L1	19.9	12.9	60.0
5.694000	47.6	Off	L1	19.9	12.4	60.0
5.782000	46.5	Off	L1	19.9	13.5	60.0
5.862000	45.7	Off	L1	19.9	14.3	60.0
5.926000	45.1	Off	L1	19.9	14.9	60.0
6.038000	45.3	Off	L1	19.9	14.7	60.0
6.102000	46.4	Off	L1	19.9	13.6	60.0
6.182000	46.9	Off	L1	19.9	13.1	60.0
6.254000	44.9	Off	L1	19.9	15.1	60.0
13.558000	50.9	Off	L1	20.3	9.1	60.0
21.990000	39.9	Off	L1	20.8	20.1	60.0



Test Mode :	NFC Tx	Test Voltage :	120Vac / 60Hz
Function Type :	GSM850 Idle + Bluetooth Link + WLAN Link + Earphone + Battery 1 + USB Cable (Charging from Adapter 1) + NFC Tx		

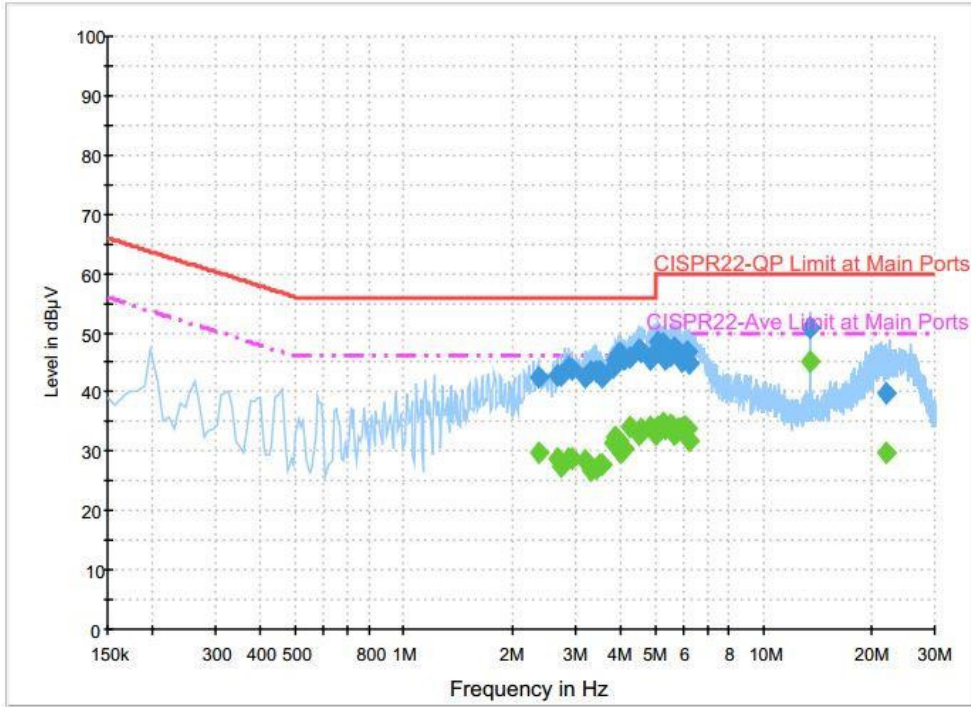

Final Result : Average

Frequency (MHz)	Average (dBµV)	Filter	Line	Corr. (dB)	Margin (dB)	Limit (dBµV)
2.366000	29.7	Off	L1	19.6	16.3	46.0
2.678000	28.6	Off	L1	19.7	17.4	46.0
2.734000	27.5	Off	L1	19.7	18.5	46.0
2.870000	28.6	Off	L1	19.7	17.4	46.0
2.942000	28.8	Off	L1	19.7	17.2	46.0
3.190000	28.4	Off	L1	19.7	17.6	46.0
3.310000	26.8	Off	L1	19.7	19.2	46.0
3.446000	27.2	Off	L1	19.7	18.8	46.0
3.518000	27.7	Off	L1	19.8	18.3	46.0
3.574000	27.9	Off	L1	19.8	18.1	46.0
3.814000	31.5	Off	L1	19.8	14.5	46.0
3.878000	32.6	Off	L1	19.8	13.4	46.0
3.950000	31.8	Off	L1	19.8	14.2	46.0
4.030000	29.9	Off	L1	19.8	16.1	46.0
4.094000	30.3	Off	L1	19.8	15.7	46.0
4.278000	34.0	Off	L1	19.8	12.0	46.0
4.542000	32.8	Off	L1	19.8	13.2	46.0
4.598000	33.7	Off	L1	19.8	12.3	46.0
4.862000	34.1	Off	L1	19.8	11.9	46.0



Test Mode :	NFC Tx	Test Voltage :	120Vac / 60Hz
Function Type :	GSM850 Idle + Bluetooth Link + WLAN Link + Earphone + Battery 1 + USB Cable (Charging from Adapter 1) + NFC Tx		

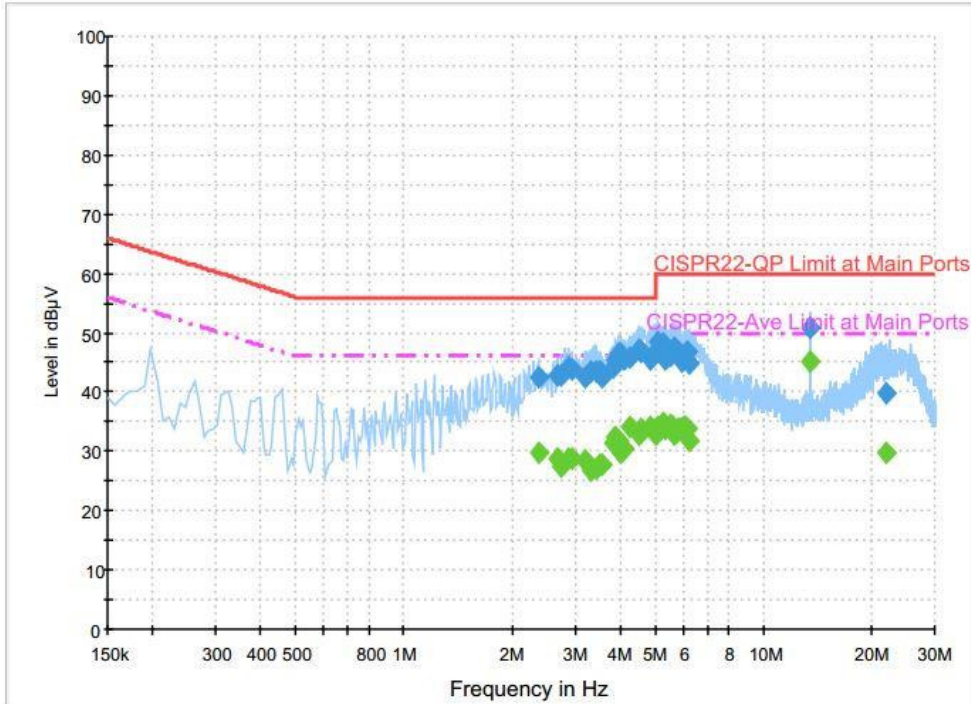

Final Result : Average

Frequency (MHz)	Average (dBµV)	Filter	Line	Corr. (dB)	Margin (dB)	Limit (dBµV)
5.038000	32.8	Off	L1	19.8	17.2	50.0
5.118000	34.1	Off	L1	19.8	15.9	50.0
5.262000	34.9	Off	L1	19.9	15.1	50.0
5.366000	33.9	Off	L1	19.9	16.1	50.0
5.510000	34.4	Off	L1	19.9	15.6	50.0
5.598000	34.0	Off	L1	19.9	16.0	50.0
5.694000	32.8	Off	L1	19.9	17.2	50.0
5.782000	33.9	Off	L1	19.9	16.1	50.0
5.862000	33.9	Off	L1	19.9	16.1	50.0
5.926000	33.8	Off	L1	19.9	16.2	50.0
6.038000	34.1	Off	L1	19.9	15.9	50.0
6.102000	34.2	Off	L1	19.9	15.8	50.0
6.182000	33.8	Off	L1	19.9	16.2	50.0
6.254000	31.9	Off	L1	19.9	18.1	50.0
13.558000	45.2	Off	L1	20.3	4.8	50.0
21.990000	29.8	Off	L1	20.8	20.2	50.0



Test Mode :	NFC Tx	Test Voltage :	120Vac / 60Hz
Function Type :	GSM850 Idle + Bluetooth Link + WLAN Link + Earphone + Battery 1 + USB Cable (Charging from Adapter 1) + NFC Tx		

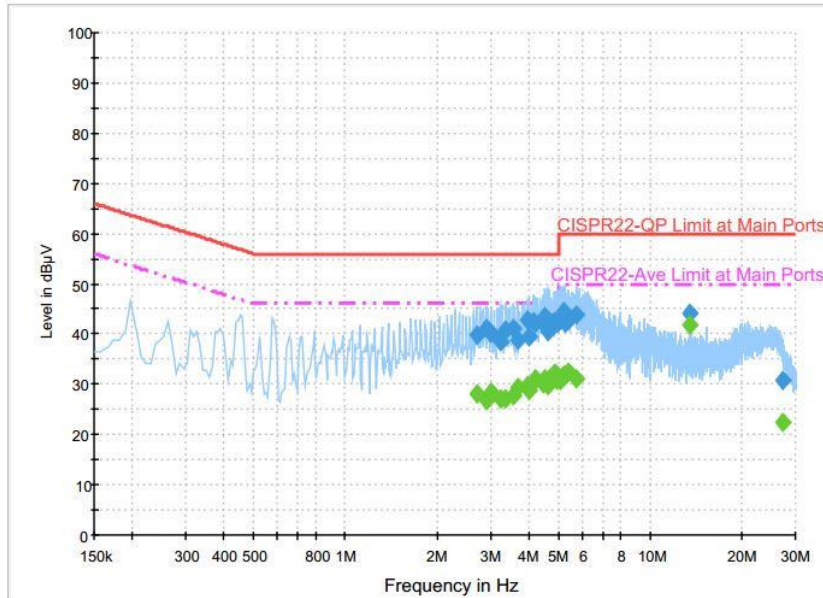

Final Result : Quasi-Peak

Frequency (MHz)	Quasi-Peak (dBµV)	Filter	Line	Corr. (dB)	Margin (dB)	Limit (dBµV)
2.694000	39.8	Off	N	19.7	16.2	56.0
2.894000	41.1	Off	N	19.7	14.9	56.0
3.022000	40.1	Off	N	19.7	15.9	56.0
3.222000	38.4	Off	N	19.7	17.6	56.0
3.350000	40.9	Off	N	19.7	15.1	56.0
3.550000	41.1	Off	N	19.7	14.9	56.0
3.678000	38.9	Off	N	19.7	17.1	56.0
3.942000	42.8	Off	N	19.7	13.2	56.0
4.014000	39.3	Off	N	19.7	16.7	56.0
4.142000	42.4	Off	N	19.8	13.6	56.0
4.206000	42.2	Off	N	19.8	13.8	56.0
4.470000	42.2	Off	N	19.8	13.8	56.0
4.534000	43.4	Off	N	19.8	12.6	56.0
4.606000	40.5	Off	N	19.8	15.5	56.0
4.662000	42.2	Off	N	19.8	13.8	56.0
4.862000	42.3	Off	N	19.8	13.7	56.0
4.926000	42.3	Off	N	19.8	13.7	56.0
4.990000	42.1	Off	N	19.8	13.9	56.0
5.062000	42.7	Off	N	19.8	17.3	60.0
5.190000	44.6	Off	N	19.8	15.4	60.0
5.262000	42.3	Off	N	19.8	17.7	60.0
5.390000	42.8	Off	N	19.8	17.2	60.0
5.718000	43.8	Off	N	19.8	16.2	60.0
13.558000	44.1	Off	N	20.3	15.9	60.0
27.118000	30.8	Off	N	21.2	29.2	60.0



Test Mode :	NFC Tx	Test Voltage :	120Vac / 60Hz
Function Type :	GSM850 Idle + Bluetooth Link + WLAN Link + Earphone + Battery 1 + USB Cable (Charging from Adapter 1) + NFC Tx		

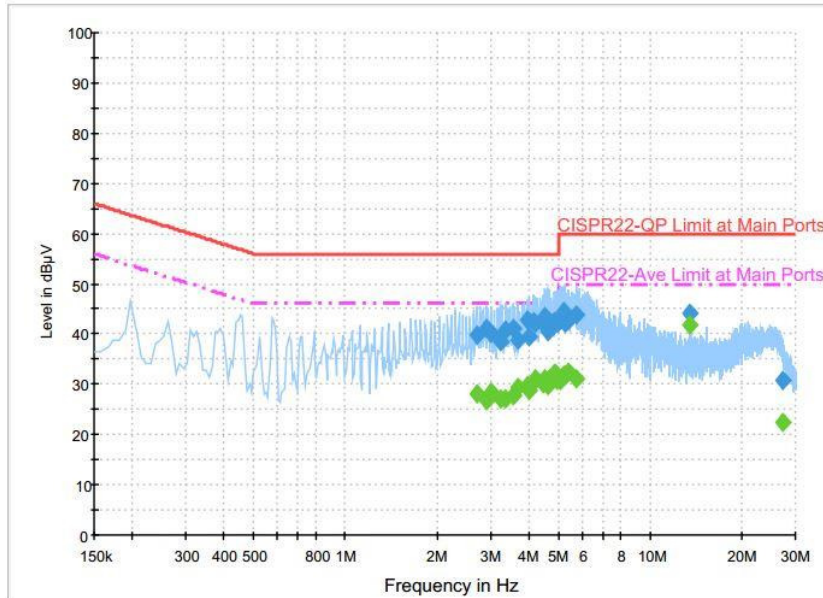

Final Result : Average

Frequency (MHz)	Average (dBµV)	Filter	Line	Corr. (dB)	Margin (dB)	Limit (dBµV)
2.694000	28.0	Off	N	19.7	18.0	46.0
2.894000	26.8	Off	N	19.7	19.2	46.0
3.022000	28.3	Off	N	19.7	17.7	46.0
3.222000	27.1	Off	N	19.7	18.9	46.0
3.350000	27.0	Off	N	19.7	19.0	46.0
3.550000	27.8	Off	N	19.7	18.2	46.0
3.678000	29.4	Off	N	19.7	16.6	46.0
3.942000	29.8	Off	N	19.7	16.2	46.0
4.014000	28.9	Off	N	19.7	17.1	46.0
4.142000	30.5	Off	N	19.8	15.5	46.0
4.206000	31.0	Off	N	19.8	15.0	46.0
4.470000	30.1	Off	N	19.8	15.9	46.0
4.534000	31.0	Off	N	19.8	15.0	46.0
4.606000	29.9	Off	N	19.8	16.1	46.0
4.662000	31.2	Off	N	19.8	14.8	46.0
4.862000	32.2	Off	N	19.8	13.8	46.0
4.926000	32.0	Off	N	19.8	14.0	46.0
4.990000	30.9	Off	N	19.8	15.1	46.0
5.062000	30.8	Off	N	19.8	19.2	50.0
5.190000	31.9	Off	N	19.8	18.1	50.0
5.262000	31.7	Off	N	19.8	18.3	50.0
5.390000	32.3	Off	N	19.8	17.7	50.0
5.718000	31.1	Off	N	19.8	18.9	50.0
13.558000	41.9	Off	N	20.3	8.1	50.0
27.118000	22.3	Off	N	21.2	27.7	50.0



(1) with antenna

Remark: 13.558MHz is the NFC RF fundamental signal.

(2) with dummy load

Remark: Only the fundamental NFC signal needs to be retested per C63.4.



Appendix B. Test Results of Conducted Test Items

B.1 Test Result of 20dB Spectrum Bandwidth

Test mode	NFC Tx	Test Frequency (MHz)	13.56
Date: 27.MAY.2016 09:27:03		Date: 27.MAY.2016 09:35:36	
20dB Bandwidth (kHz)	2.640	99% OccupiedBW(kHz)	2.240
Frequency range (MHz)	$f_L > 13.553$	13.55866	Test Result
	$f_H < 13.567$	13.56130	Complies



B.2 Test Result of Frequency Stability

Voltage vs. Frequency Stability		Temperature vs. Frequency Stability		
Voltage (Vac)	Measurement Frequency (MHz)	Temperature (°C)	Time	Measurement Frequency (MHz)
120	13.559980	-20	0	13.560030
102	13.559980		2	13.560020
138	13.559980		5	13.560020
			10	13.560010
		-10	0	13.560040
			2	13.560030
			5	13.560020
			10	13.559980
		0	0	13.560020
			2	13.560020
			5	13.560010
			10	13.560000
		10	0	13.560010
			2	13.560000
			5	13.560000
			10	13.559990
		20	0	13.560000
			2	13.560000
			5	13.559980
			10	13.559980
		30	0	13.559980
			2	13.559980
			5	13.559980
			10	13.559980
		40	0	13.559960
			2	13.559960
			5	13.559960
			10	13.559960



Voltage vs. Frequency Stability		Temperature vs. Frequency Stability		
Voltage (Vac)	Measurement Frequency (MHz)	Temperature (°C)	Time	Measurement Frequency (MHz)
		50	0	13.559940
			2	13.559940
			5	13.559940
			10	13.559950
Max.Deviation (MHz)	-0.000020	Max.Deviation (MHz)		-0.000060
Max.Deviation (ppm)	-1.4749	Max.Deviation (ppm)		-4.4248
Limit	FS < ±100 ppm	Limit		FS < ±100 ppm
Test Result	PASS	Test Result		PASS



Appendix C. Test Results of Radiated Test Items

C.1 Test Result of Field Strength of Fundamental Emissions

Test Mode :	NFC Tx	Test Frequency (MHz)	13.56	
--------------------	--------	-----------------------------	-------	--

Date: 2016-06-02

Site : 03CH13-HY
 Condition : 15.225 3m LOOP_ANT(H) HORIZONTAL
 Project : FR 651022
 Mode : 1

Over	Limit	ReadAntenna	Cable	A/Pos	T/Pos	Remark				
Line	Line	Level	Loss							
		Factor								
MHz	dBuV/m	dB	dBuV/m	dBuV	dB/m	dB	cm	deg		
1	13.56	63.26	-60.74	124.00	42.53	20.05	0.68	100	6	QP

Date: 2016-06-02

Site : 03CH13-HY
 Condition : 15.225 3m LOOP_ANT(V) VERTICAL
 Project : FR 651022
 Mode : 1

Over	Limit	ReadAntenna	Cable	A/Pos	T/Pos	Remark				
Line	Line	Level	Loss							
		Factor								
MHz	dBuV/m	dB	dBuV/m	dBuV	dB/m	dB	cm	deg		
1	13.56	59.21	-64.79	124.00	38.48	20.05	0.68	100	280	QP

Note: All NFC's spurious emissions are below 20dB of limits.

C.2 Results of Radiated Emissions (9 kHz~30MHz)

Test Mode :		NFC Tx			Polarization :		Horizontal		
Frequency (MHz)	Level (dBμV/m)	Over Limit (dB)	Limit Line (dBμV/m)	Read Level (dBμV)	Antenna Factor (dB)	Cable Loss (dB)	Ant Pos (cm)	Table Pos (deg)	Remark
0.02379	59.6	-60.48	120.08	38.67	20.25	0.68			Average
0.06471	54.96	-56.42	111.38	34.24	20.04	0.68			Average
0.0904	45.19	-63.29	108.48	24.52	19.99	0.68			QP
0.12944	49.48	-55.88	105.36	28.83	19.97	0.68			Average
0.19318	46.58	-55.3	101.88	25.97	19.93	0.68			Average
0.49751	39.63	-34.04	73.67	19.05	19.9	0.68			QP
13.56	63.13	-6.37	69.5	42.4	20.05	0.68			QP
13.768	44.31	-25.19	69.5	23.58	20.05	0.68	100	4	QP
20.329	34.21	-35.29	69.5	12.69	20.45	1.07			QP
26.47	33.92	-35.58	69.5	12.23	20.62	1.07			QP

Test Mode :		NFC Tx			Polarization :		Vertical		
Frequency (MHz)	Level (dBμV/m)	Over Limit (dB)	Limit Line (dBμV/m)	Read Level (dBμV)	Antenna Factor (dB)	Cable Loss (dB)	Ant Pos (cm)	Table Pos (deg)	Remark
0.009	57.08	-71.44	128.52	36.15	20.25	0.68			Average
0.06471	51.55	-59.83	111.38	30.83	20.04	0.68			Average
0.10612	37.43	-69.66	107.09	16.76	19.99	0.68			QP
0.12944	44.62	-60.74	105.36	23.97	19.97	0.68			Average
0.19284	44.6	-57.3	101.9	23.99	19.93	0.68			Average
0.49751	37.1	-36.57	73.67	16.52	19.9	0.68			QP
13.56	58.99	-10.51	69.5	38.26	20.05	0.68			QP
13.768	39.47	-30.03	69.5	18.74	20.05	0.68	100	277	QP
20.149	37.41	-32.09	69.5	15.91	20.43	1.07			QP
26.475	33.47	-36.03	69.5	11.78	20.62	1.07			QP

Note:

- 13.56 MHz is fundamental signal which can be ignored.
- The amplitude of spurious emissions which are attenuated by more than 20dB below the permissible value has no need to be reported.
- Distance extrapolation factor = 40 log (specific distance / test distance) (dB);
- Limit line = specific limits (dBμV) + distance extrapolation factor.



D.3 Results of Radiated Emissions (30MHz~1GHz)

Test Mode :	NFC Tx	Polarization :	Horizontal
-------------	--------	----------------	------------

Frequency (MHz)	Level (dBμV/m)	Over Limit (dB)	Limit Line (dBμV/m)	Read Level (dBμV)	Antenna Factor (dB)	Cable Loss (dB)	Preamp Factor (dB)	Ant Pos (cm)	Table Pos (deg)	Remark
98.04	25.39	-18.11	43.5	40.42	15.84	1.02	31.89			Peak
147.45	25.69	-17.81	43.5	38.69	17.58	1.27	31.85			Peak
210.09	23.97	-19.53	43.5	38.12	16.1	1.55	31.8			Peak
738.9	28.8	-17.2	46	30.58	27.12	3.09	31.99			Peak
836.2	29.71	-16.29	46	29.93	28.16	3.4	31.78			Peak
941.2	32.49	-13.51	46	30.36	29.89	3.44	31.2	121	155	Peak

Test Mode :	NFC Tx	Polarization :	Vertical
-------------	--------	----------------	----------

Frequency (MHz)	Level (dBμV/m)	Over Limit (dB)	Limit Line (dBμV/m)	Read Level (dBμV)	Antenna Factor (dB)	Cable Loss (dB)	Preamp Factor (dB)	Ant Pos (cm)	Table Pos (deg)	Remark
40.8	36.21	-3.79	40	47.88	19.64	0.62	31.93	102	54	QP
102.36	26.22	-17.28	43.5	40.67	16.4	1.04	31.89			Peak
184.17	22.11	-21.39	43.5	37.16	15.34	1.43	31.82			Peak
795.6	29.72	-16.28	46	30.62	27.76	3.26	31.92			Peak
891.5	30.88	-15.12	46	30.21	28.8	3.44	31.57			Peak
953.8	31.22	-14.78	46	28.74	30.12	3.45	31.09			Peak

Note:

1. The amplitude of spurious emissions which are attenuated by more than 20dB below the permissible value has no need to be reported.
2. Emission level (dBμV/m) = 20 log Emission level (μV/m).
3. Corrected Reading: Antenna Factor + Cable Loss + Read Level - Preamp Factor= Level.