



FCC Test Report

APPLICANT : Motorola Mobility, LLC
EQUIPMENT : Mobile Cellular Phone
BRAND NAME : Motorola
MODEL NAME : 4237
FCC ID : IHDT56VB1
STANDARD : FCC 47 CFR FCC Part 15 Subpart B
CLASSIFICATION : Verification

This is a variant report which is only valid together with the original test report. The product was received on May 17, 2016 and testing was completed on May 22, 2016. We, SPORTON INTERNATIONAL INC., would like to declare that the tested sample has been evaluated in accordance with the test procedures given in ANSI C63.4-2014 and has been in compliance with the applicable technical standards.

The test results in this report apply exclusively to the tested model / sample. Without written approval of SPORTON INTERNATIONAL INC., the test report shall not be reproduced except in full.

Reviewed by: Louis Wu / Manager

Approved by: Jones Tsai / Manager



SPORTON INTERNATIONAL INC.

No. 52, Hwa Ya 1st Rd., Hwa Ya Technology Park, Kwei-Shan District, Tao Yuan City, Taiwan, R.O.C.

SPORTON INTERNATIONAL INC.

TEL : 886-3-327-3456

FAX : 886-3-328-4978

FCC ID : IHDT56VB1

Page Number : 1 of 21

Report Issued Date : Jun. 01, 2016

Report Version : Rev. 01

Report Template No.: BU5-FD15B Version 1.2



TABLE OF CONTENTS

REVISION HISTORY..... 3

SUMMARY OF TEST RESULT 4

1. GENERAL DESCRIPTION 5

 1.1. Applicant..... 5

 1.2. Manufacturer 5

 1.3. Product Feature of Equipment Under Test 5

 1.4. Product Specification of Equipment Under Test 6

 1.5. Modification of EUT 7

 1.6. Test Location 7

 1.7. Applicable Standards 8

2. TEST CONFIGURATION OF EQUIPMENT UNDER TEST 9

 2.1. Test Mode 9

 2.2. Connection Diagram of Test System 10

 2.3. Support Unit used in test configuration and system 11

 2.4. EUT Operation Test Setup 11

3. TEST RESULT 12

 3.1. Test of AC Conducted Emission Measurement 12

 3.2. Test of Radiated Emission Measurement 16

4. LIST OF MEASURING EQUIPMENT 20

5. UNCERTAINTY OF EVALUATION 21

APPENDIX A. ORIGINAL REPORT



SUMMARY OF TEST RESULT

Report Section	FCC Rule	Description	Limit	Result	Remark
3.1	15.107	AC Conducted Emission	< 15.107 limits	PASS	Under limit 4.50 dB at 4.774 MHz
3.2	15.109	Radiated Emission	< 15.109 limits	PASS	Under limit 5.19 dB at 91.290 MHz



1. General Description

1.1. Applicant

Motorola Mobility, LLC

222 W Merchandise Mart Plaza, Suite 1800, Chicago, IL 60654, United States

1.2. Manufacturer

Motorola Mobility, LLC

222 W Merchandise Mart Plaza, Suite 1800, Chicago, IL 60654, United States

1.3. Product Feature of Equipment Under Test

Product Feature	
Equipment	Mobile Cellular Phone
Brand Name	Motorola
Model Name	4237
FCC ID	IHDT56VB1
IMEI Code	354107070049056
EUT supports Radios application	CDMA/EV-DO/GSM/EGPRS/WCDMA/HSPA/LTE/NFC WLAN 11b/g/n HT20 WLAN 11a/n HT20/HT40 WLAN 11ac VHT20/VHT40/VHT80 Bluetooth v3.0 EDR Bluetooth v4.2 LE
HW Version	DVT2
EUT Stage	Identical Prototype

Remark: The above EUT's information was declared by manufacturer. Please refer to the specifications or user's manual for more detailed description.

Accessory List	
WPC Cover	Brand Name : INCIPIO
	Model Name : MT-043-CASE



1.4. Product Specification of Equipment Under Test

Standards-related Product Specification	
Tx Frequency	GSM850: 824.2 MHz ~ 848.8 MHz GSM1900: 1850.2 MHz ~ 1909.8MHz WCDMA Band V: 826.4 MHz ~ 846.6 MHz WCDMA Band II: 1852.4 MHz ~ 1907.6 MHz CDMA2000 BC0: 824.70 MHz ~ 848.31 MHz CDMA2000 BC1: 1851.25 MHz ~ 1908.75 MHz LTE Band 5 : 824.7 MHz ~ 848.3 MHz LTE Band 2 : 1850.7 MHz ~ 1909.3 MHz LTE Band 4 : 1710.7 MHz ~ 1754.3 MHz LTE Band 7 : 2502.5 MHz ~ 2567.5 MHz LTE Band 13 : 779.5 MHz ~ 784.5 MHz 802.11b/g/n: 2412 MHz ~ 2462 MHz 802.11a/n/ac: 5180 MHz ~ 5240 MHz; 5260 MHz ~ 5320 MHz; 5500 MHz ~ 5700 MHz ; 5745 MHz ~ 5825 MHz Bluetooth: 2402 MHz ~ 2480 MHz NFC : 13.56 MHz
Rx Frequency	GSM850: 869.2 MHz ~ 893.8 MHz GSM1900: 1930.2 MHz ~ 1989.8 MHz WCDMA Band V: 871.4 MHz ~ 891.6 MHz WCDMA Band II: 1932.4 MHz ~ 1987.6 MHz CDMA2000 BC0: 869.70 MHz ~ 893.31 MHz CDMA2000 BC1: 1931.25 MHz ~ 1988.75 MHz LTE Band 5 : 869.7 MHz ~ 893.3 MHz LTE Band 2 : 1930.7 MHz ~ 1989.3 MHz LTE Band 4 : 2110.7 MHz ~ 2154.3 MHz LTE Band 7 : 2622.5MHz ~ 2687.5 MHz LTE Band 13 : 748.5 MHz ~ 753.5 MHz 802.11b/g/n: 2412 MHz ~ 2462 MHz 802.11a/n/ac: 5180 MHz ~ 5240 MHz; 5260 MHz ~ 5320 MHz; 5500 MHz ~ 5700 MHz ; 5745 MHz ~ 5825 MHz Bluetooth: 2402 MHz ~ 2480 MHz GPS : 1.57542 GHz NFC : 13.56 MHz
Antenna Type	WWAN : Fixed Internal Antenna WLAN : Fixed Internal Antenna Bluetooth : Fixed Internal Antenna GPS : Fixed Internal Antenna NFC: Fixed Internal Antenna

Standards-related Product Specification	
Type of Modulation	GSM: GMSK GPRS: GMSK EDGE(MCS 0-4): GMSK / (MCS 5-9): 8PSK WCDMA: QPSK (Uplink) HSDPA: 64QAM (Downlink) HSUPA: QPSK (Uplink) CDMA2000 : QPSK CDMA2000 1xEV-DO : 8PSK LTE: QPSK / 16QAM 802.11b : DSSS (DBPSK / DQPSK / CCK) 802.11a/g/n : OFDM (BPSK / QPSK / 16QAM / 64QAM) 802.11ac : OFDM (BPSK / QPSK / 16QAM / 64QAM /256QAM) Bluetooth LE : GFSK Bluetooth (1Mbps) : GFSK Bluetooth (2Mbps) : $\pi/4$ -DQPSK Bluetooth (3Mbps) : 8-DPSK GPS : BPSK NFC: ASK

1.5. Modification of EUT

No modifications are made to the EUT during all test items.

1.6. Test Location

Sporton Lab is accredited to ISO 17025 by Taiwan Accreditation Foundation (TAF code : 1190) and the FCC designation No. TW1022 under the FCC 2.948(e) by Mutual Recognition Agreement (MRA) in FCC Test.

Test Site	SPORTON INTERNATIONAL INC.	
Test Site Location	No. 52, Hwa Ya 1 st Rd., Hwa Ya Technology Park, Kwei-Shan District, Tao Yuan City, Taiwan, R.O.C. TEL: +886-3-327-3456 FAX: +886-3-328-4978	
Test Site No.	Sporton Site No.	
	CO05-HY	03CH06-HY



1.7. Applicable Standards

According to the specifications of the manufacturer, the EUT must comply with the requirements of the following standards:

- ♦ FCC 47 CFR FCC Part 15 Subpart B
- ♦ ANSI C63.4-2014

Remark:

1. All test items were verified and recorded according to the standards and without any deviation during the test.
2. For FCC 15 Subpart B - Unintentional Radiators, receivers contained within a transceiver shall be authorized under the verification procedure per the Section 15.101 (b).
3. For other Unintentional Radiators features of this EUT, test reports are be issued separately.
Per the Note of the Section 15.101, when device supports features (USB, FM Radio, digital devices...etc) more than one category of authorization, type of authorization shall be appropriately chosen for FCC 15B compliance rule, and the Section 15.101 (b), only those receivers that operate (tune) within the frequency range of 30-960 MHz, CB receivers and radar detectors are subject to the authorizations shown in paragraph (a) of the Section 15.101. However, receivers indicated as being subject to Declaration of Conformity that are contained within a transceiver, the transmitter portion of which is subject to certification, shall be authorized under the verification procedure.
4. Receivers operating above 960 MHz or below 30 MHz, except for radar detectors and CB receivers, are exempt from complying with the technical provisions of this part but are subject to § 15.5.



2. Test Configuration of Equipment Under Test

2.1. Test Mode

The EUT has been associated with peripherals pursuant to ANSI C63.4-2014 and configuration operated in a manner tended to maximize its emission characteristics in a typical application.

Frequency range investigated: conduction (150 kHz to 30 MHz), radiation (30MHz to the 5th harmonic of the highest fundamental frequency or to 40 GHz, whichever is lower).

The following tables are showing the test modes as the worst cases and recorded in this report.

Item	EUT Configuration	Test Condition		
		EMI AC	EMI RE<1G	EMI RE≥1G
1.	Charging Mode (EUT with adapter)	☒	☒	☒

Abbreviations:

- EMI AC: AC conducted emissions
- EMI RE ≥ 1G: EUT radiated emissions ≥ 1GHz
- EMI RE < 1G: EUT radiated emissions < 1GHz

Test Items	EUT Configure Mode	Function Type
AC Conducted Emission	1	Mode 1 : GSM1900 Idle + Bluetooth Idle + WLAN Idle + Camera + WPC Back Cover + Battery + LG Charging Pad + USB Cable (Charging from Adapter) Mode 2 : WCDMA Band V Idle + Bluetooth Idle + WLAN Idle + NFC on + WPC Back Cover + Battery + PMA Charging Pad + Adapter
Radiated Emissions < 1GHz	1	Mode 1 : GSM1900 Idle + Bluetooth Idle + WLAN Idle + Camera + WPC Back Cover + Battery + LG Charging Pad + USB Cable (Charging from Adapter) Mode 2 : WCDMA Band V Idle + Bluetooth Idle + WLAN Idle + NFC on + WPC Back Cover + Battery + PMA Charging Pad + Adapter
Radiated Emissions ≥ 1GHz	1	Mode 1 : GSM1900 Idle + Bluetooth Idle + WLAN Idle + Camera + WPC Back Cover + Battery + LG Charging Pad + USB Cable (Charging from Adapter)
Remark:		
1. The worst case of AC is mode 2; only the test data of this mode was reported.		
2. The worst case of RE < 1G is mode 1; only the test data of this mode was reported.		

2.2. Connection Diagram of Test System

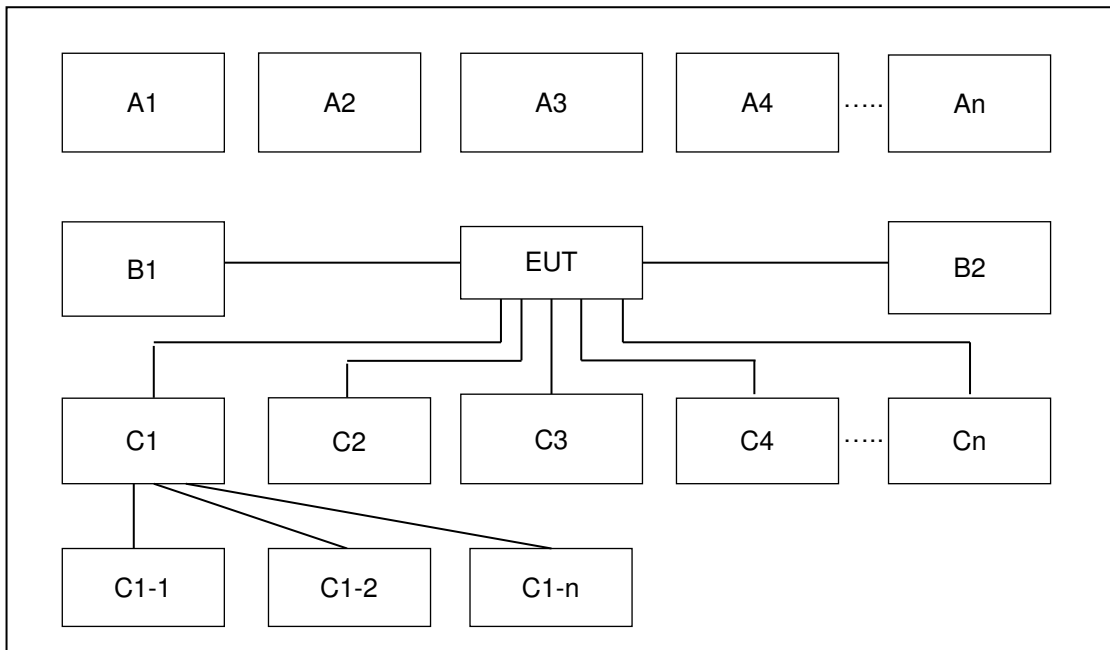

Conduction & Radiation Test Setup									
No.	Wireless Station	Connection Type	Test Mode						
			1	2	-	-	-	-	-
A1	Bluetooth Earphone	Bluetooth	X	X					
A2	System Simulator	GSM/UMTS/CDMA/ WCDMA/LTE	X	X					
A3	AP router	WiFi	X	X					
A4	WPC pad	WPC	X						
A5	PMA pad	PMA		X					
No.	Power Source	Connection Type	1	2	-	-	-	-	-
A4-1	AC : 120V/60Hz	AC Power Cable	X						
A5-1	AC : 120V/60Hz	AC Power Cable		X					
No.	Setup Peripherals	Connection Type	1	2	-	-	-	-	-
C1	SD card	SD I/O interface without Cable	X	X					



2.3. Support Unit used in test configuration and system

Item	Equipment	Trade Name	Model Name	FCC ID	Data Cable	Power Cord
1.	System Simulator	R&S	CMU 200	N/A	N/A	Unshielded, 1.8 m
2.	System Simulator	Anritsu	MT8820C	N/A	N/A	Unshielded, 1.8 m
3.	WLAN AP	D-Link	DIR-628	KA2DIR628A2	N/A	Unshielded, 1.8 m
4.	WLAN AP	D-Link	DIR-865L	KA2IR865LA1	N/A	Unshielded, 1.8 m
5.	Bluetooth Earphone	Sony Ericsson	MW600	PY7DDA-2029	N/A	N/A
6.	SD Card	SanDisk	MicroSD HC	FCC DoC	N/A	N/A
7.	Wireless Charger	LG	WCD-100	FCC DoC	N/A	N/A
8.	PMA	DURACELL	M-018B-518A	FCC DoC	N/A	N/A
9.	USB Cable	Motorola	SKN6461A	N/A	Unshielded, 1.0 m	N/A
10.	Adapter	Motorola	SPN5865A	N/A	N/A	N/A

2.4. EUT Operation Test Setup

The EUT was in GSM or WCDMA idle mode during the testing. The EUT was synchronized to the BCCH, and is in continuous receiving mode by setting system simulator's paging reorganization.

The EUT was attached to the Bluetooth earphone or WLAN AP, and the following programs installed in the EUT were programmed during the test.

1. Turn on camera to capture images.
2. Turn on the NFC function.



3. Test Result

3.1. Test of AC Conducted Emission Measurement

3.1.1 Limits of AC Conducted Emission

For equipment that is designed to be connected to the public utility (AC) power line, the radio frequency voltage that is conducted back onto the AC power line on any frequency or frequencies within the band 150 kHz to 30 MHz shall not exceed the limits in the following table.

Frequency of emission (MHz)	Conducted limit (dBuV)	
	Quasi-peak	Average
0.15-0.5	66 to 56*	56 to 46*
0.5-5	56	46
5-30	60	50

*Decreases with the logarithm of the frequency.

3.1.2 Measuring Instruments

The measuring equipment is listed in the section 4 of this test report.

3.1.3 Test Procedure

1. The EUT was placed 0.4 meter from the conducting wall of the shielding room was kept at least 80 centimeters from any other grounded conducting surface.
2. Connect EUT to the power mains through a line impedance stabilization network (LISN).
3. All the support units are connecting to the other LISN.
4. The LISN provides 50 ohm coupling impedance for the measuring instrument.
5. The FCC states that a 50 ohm, 50 microhenry LISN should be used.
6. Both sides of AC line were checked for maximum conducted interference.
7. The frequency range from 150 kHz to 30 MHz was searched.
8. Set the test-receiver system to Peak Detect Function and specified bandwidth (IF Bandwidth = 9kHz) with Maximum Hold Mode. Then measurement is also conducted by Average Detector and Quasi-Peak Detector Function respectively.

3.1.4 Test Setup

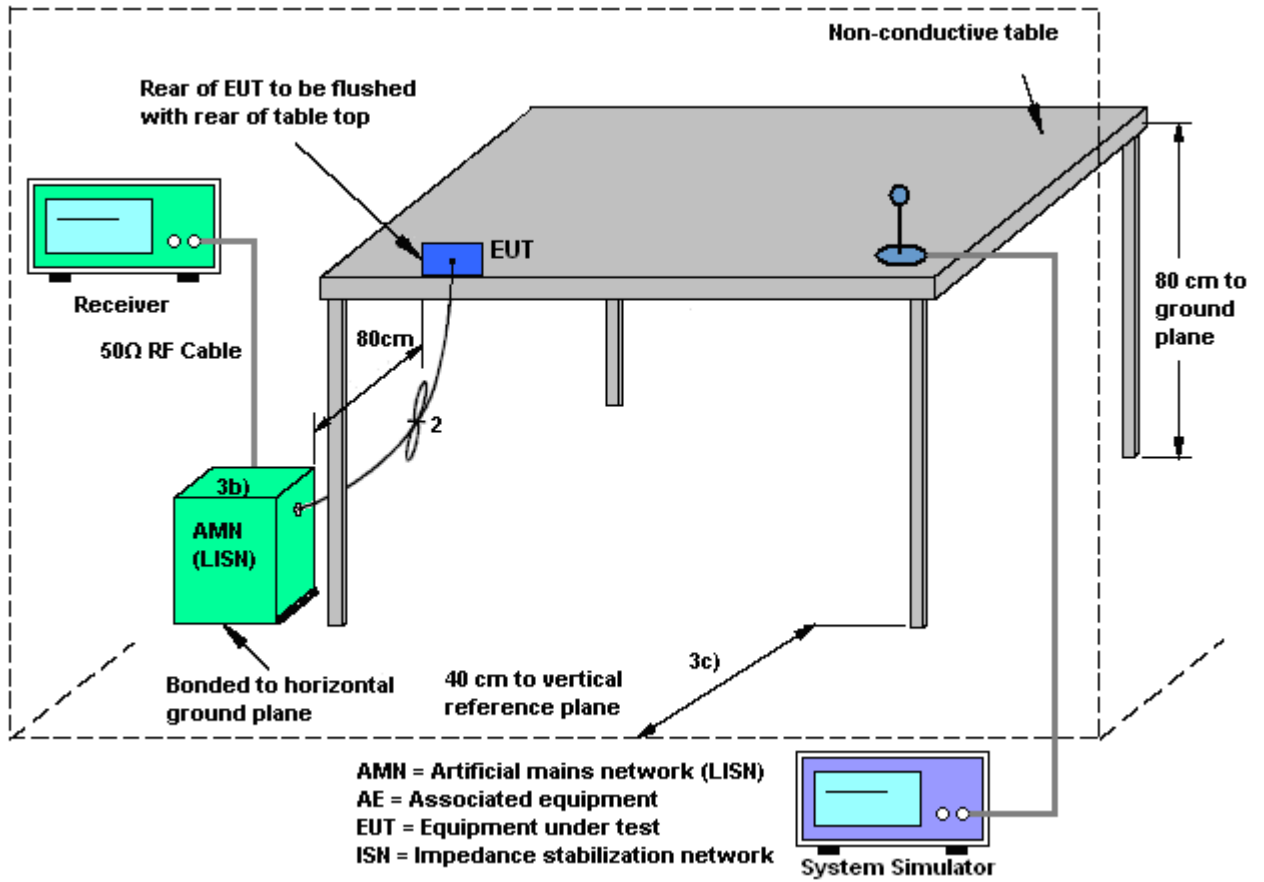

3.1.5 Test Result of AC Conducted Emission

Test Mode :	Mode 2	Temperature :	23~24°C
Test Engineer :	Kai-Chun Chu	Relative Humidity :	44~45%
Test Voltage :	120Vac / 60Hz	Phase :	Line
Function Type :	WCDMA Band V Idle + Bluetooth Idle + WLAN Idle + NFC on + WPC Back Cover + Battery + PMA Charging Pad + Adapter		

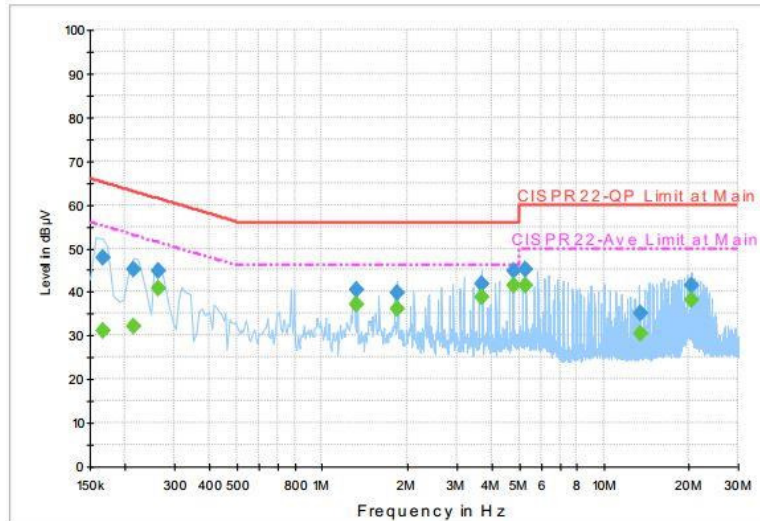

Final Result : Quasi-Peak

Frequency (MHz)	Quasi-Peak (dBµV)	Filter	Line	Corr. (dB)	Margin (dB)	Limit (dBµV)
0.166000	47.8	Off	L1	19.6	17.4	65.2
0.214000	45.1	Off	L1	19.6	17.9	63.0
0.262000	44.9	Off	L1	19.6	16.5	61.4
1.326000	40.6	Off	L1	19.7	15.4	56.0
1.854000	39.7	Off	L1	19.7	16.3	56.0
3.710000	41.9	Off	L1	19.8	14.1	56.0
4.774000	44.7	Off	L1	19.8	11.3	56.0
5.302000	45.0	Off	L1	19.9	15.0	60.0
13.558000	35.1	Off	L1	20.3	24.9	60.0
20.414000	41.4	Off	L1	20.7	18.6	60.0

Final Result : Average

Frequency (MHz)	Average (dBµV)	Filter	Line	Corr. (dB)	Margin (dB)	Limit (dBµV)
0.166000	31.2	Off	L1	19.6	24.0	55.2
0.214000	32.2	Off	L1	19.6	20.8	53.0
0.262000	40.9	Off	L1	19.6	10.5	51.4
1.326000	37.0	Off	L1	19.7	9.0	46.0
1.854000	36.0	Off	L1	19.7	10.0	46.0
3.710000	38.7	Off	L1	19.8	7.3	46.0
4.774000	41.5	Off	L1	19.8	4.5	46.0
5.302000	41.6	Off	L1	19.9	8.4	50.0
13.558000	30.4	Off	L1	20.3	19.6	50.0
20.414000	38.2	Off	L1	20.7	11.8	50.0



Test Mode :	Mode 2	Temperature :	23~24°C
Test Engineer :	Kai-Chun Chu	Relative Humidity :	44~45%
Test Voltage :	120Vac / 60Hz	Phase :	Neutral
Function Type :	WCDMA Band V Idle + Bluetooth Idle + WLAN Idle + NFC on + WPC Back Cover + Battery + PMA Charging Pad + Adapter		

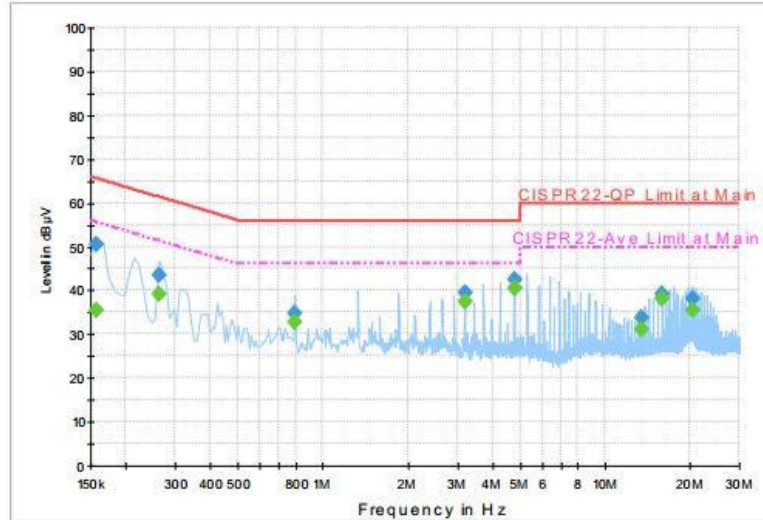

Final Result : Quasi-Peak

Frequency (MHz)	Quasi-Peak (dBµV)	Filter	Line	Corr. (dB)	Margin (dB)	Limit (dBµV)
0.158000	50.3	Off	N	19.6	15.3	65.6
0.262000	43.4	Off	N	19.6	18.0	61.4
0.798000	34.8	Off	N	19.6	21.2	56.0
3.182000	39.6	Off	N	19.7	16.4	56.0
4.774000	42.4	Off	N	19.8	13.6	56.0
13.558000	33.8	Off	N	20.3	26.2	60.0
15.910000	39.0	Off	N	20.5	21.0	60.0
20.422000	38.0	Off	N	20.8	22.0	60.0

Final Result : Average

Frequency (MHz)	Average (dBµV)	Filter	Line	Corr. (dB)	Margin (dB)	Limit (dBµV)
0.158000	35.6	Off	N	19.6	20.0	55.6
0.262000	39.1	Off	N	19.6	12.3	51.4
0.798000	32.9	Off	N	19.6	13.1	46.0
3.182000	37.3	Off	N	19.7	8.7	46.0
4.774000	40.5	Off	N	19.8	5.5	46.0
13.558000	31.1	Off	N	20.3	18.9	50.0
15.910000	38.0	Off	N	20.5	12.0	50.0
20.422000	35.6	Off	N	20.8	14.4	50.0



3.2. Test of Radiated Emission Measurement

3.2.1. Limit of Radiated Emission

The emissions from an unintentional radiator shall not exceed the field strength levels specified in the following table:

Frequency (MHz)	Field Strength (microvolts/meter)	Measurement Distance (meters)
30 – 88	100	3
88 – 216	150	3
216 - 960	200	3
Above 960	500	3

3.2.2. Measuring Instruments

The measuring equipment is listed in the section 4 of this test report.

3.2.3. Test Procedures

1. The EUT was placed on a turntable with 0.8 meter above ground.
2. The EUT was set 3 meters from the interference receiving antenna, which was mounted on the top of a variable height antenna tower.
3. The table was rotated 360 degrees to determine the position of the highest radiation.
4. The antenna is a Bi-Log antenna and its height is adjusted between one to four meters above ground to find the maximum value of the field strength for both horizontal polarization and vertical polarization of the antenna.
5. For each suspected emission, the EUT was arranged to its worst case and then tune the antenna tower (from 1 m to 4 m) and turntable (from 0 degree to 360 degrees) to find the maximum reading.
6. Set the test-receiver system to Peak Detect Function and specified bandwidth with Maximum Hold Mode (RBW=120kHz/VBW=300kHz for frequency below 1GHz; RBW=1MHz VBW=3MHz (Peak), RBW=1MHz/VBW=10Hz (Average) for frequency above 1GHz).
7. If the emission level of the EUT in peak mode was 3 dB lower than the limit specified, peak values of EUT will be reported. Otherwise, the emission will be repeated by using the quasi-peak method and reported.
8. Emission level (dBμV/m) = 20 log Emission level (μV/m)
9. Corrected Reading: Antenna Factor + Cable Loss + Read Level - Preamp Factor = Level

3.2.4. Test Setup of Radiated Emission

For radiated emissions from 30MHz to 1GHz

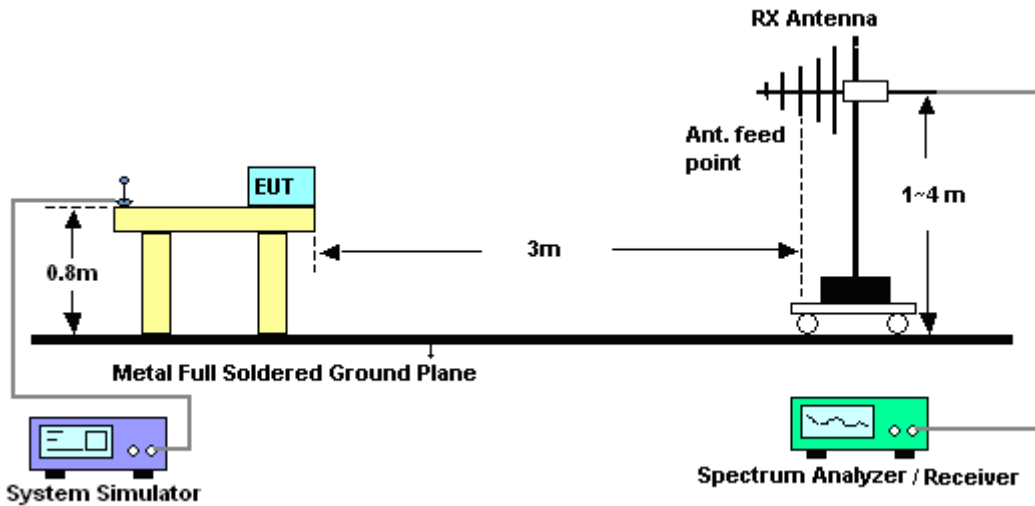

For radiated emissions above 1GHz

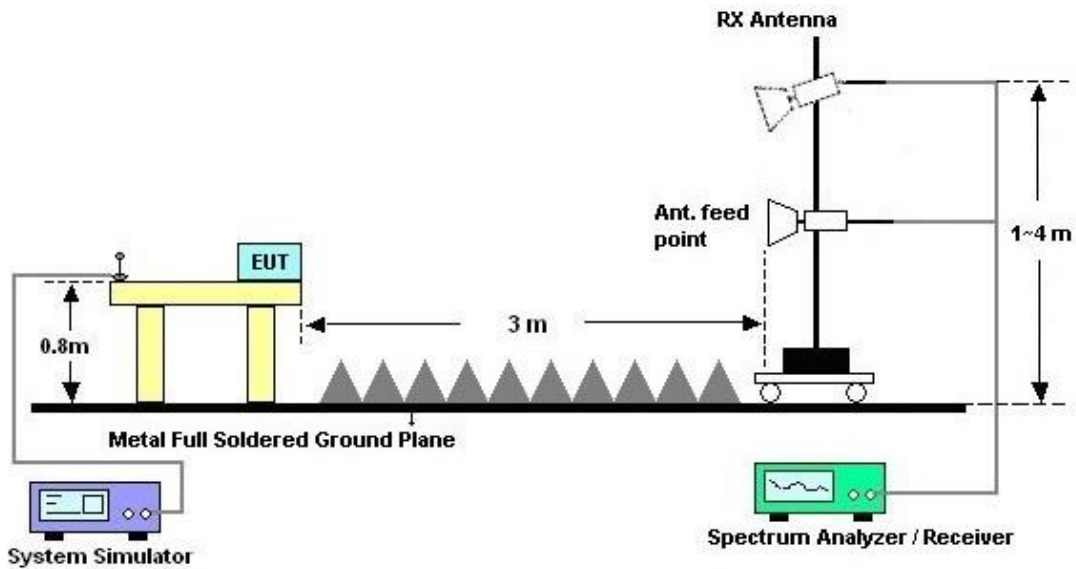



3.2.5. Test Result of Radiated Emission

Test Mode :	Mode 1	Temperature :	23~24°C
Test Engineer :	Donny Tang	Relative Humidity :	52~53%
Test Distance :	3m	Polarization :	Horizontal
Function Type :	GSM1900 Idle + Bluetooth Idle + WLAN Idle + Camera + WPC Back Cover + Battery + LG Charging Pad + USB Cable (Charging from Adapter)		
Remark :	#7 is system simulator signal which can be ignored.		

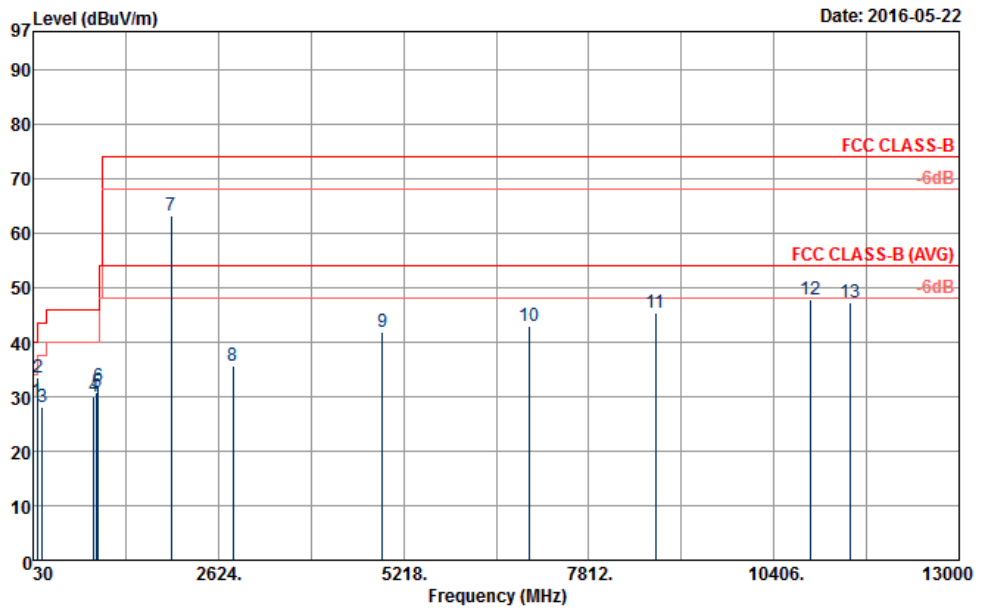

Site : 03CH06-HY
 Condition : FCC CLASS-B 3m 9120D_1156_150827 HORIZONTAL

Power : 120Vac/60Hz
 Memo : Mode 1

	Freq	Level	Over Limit	Limit Line	ReadAntenna Level	Cable Loss	Preamp Factor	A/Pos	T/Pos	Remark	
	MHz	dBuV/m	dB	dBuV/m	dBuV	dB/m	dB	dB	cm	deg	
1	91.02	29.18	-14.32	43.50	44.12	14.83	1.95	31.72	---	---	Peak
2	94.80	33.45	-10.05	43.50	47.75	15.35	2.07	31.72	100	197	Peak
3	162.30	28.17	-15.33	43.50	41.25	16.52	2.12	31.72	---	---	Peak
4	878.90	30.06	-15.94	46.00	29.04	29.27	3.36	31.61	---	---	Peak
5	921.60	30.87	-15.13	46.00	28.99	29.96	3.24	31.32	---	---	Peak
6	941.20	31.95	-14.05	46.00	29.51	30.47	3.11	31.14	---	---	Peak
7	1960.00	63.31	-----	-----	91.27	26.23	6.31	60.50	---	---	Peak
8	2830.00	35.66	-38.34	74.00	60.74	28.13	7.56	60.77	---	---	Peak
9	4926.00	42.01	-31.99	74.00	58.67	31.39	11.17	59.22	---	---	Peak
10	6980.00	42.97	-31.03	74.00	56.21	35.26	11.80	60.30	---	---	Peak
11	8750.00	45.33	-28.67	74.00	53.40	37.30	14.48	59.85	---	---	Peak
12	10910.00	47.86	-26.14	74.00	51.85	40.43	14.94	59.36	100	123	Peak
13	11464.00	47.27	-26.73	74.00	49.62	40.22	15.88	58.45	---	---	Peak



Test Mode :	Mode 1	Temperature :	23~24°C
Test Engineer :	Donny Tang	Relative Humidity :	52~53%
Test Distance :	3m	Polarization :	Vertical
Function Type :	GSM1900 Idle + Bluetooth Idle + WLAN Idle + Camera + WPC Back Cover + Battery + LG Charging Pad + USB Cable (Charging from Adapter)		
Remark :	#7 is system simulator signal which can be ignored.		

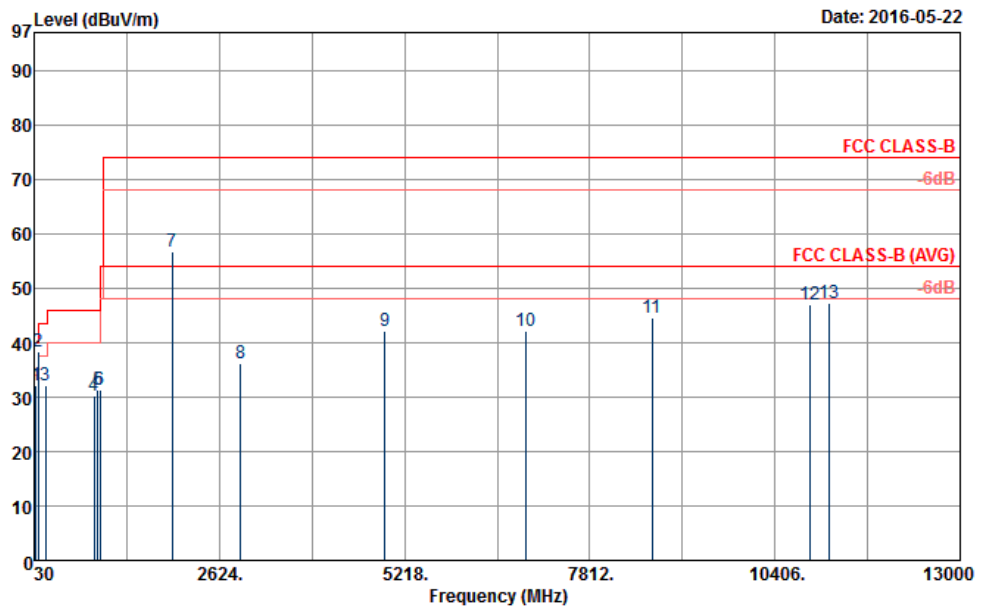

Site : 03CH06-HY
 Condition : FCC CLASS-B 3m 9120D_1156_150827 VERTICAL

Power : 120Vac/60Hz
 Memo : Mode 1

	Freq	Level	Over Limit	Limit Line	ReadAntenna Level	Cable Preamp	A/Pos	T/Pos	Remark		
	MHz	dBuV/m	dB	dBuV/m	dBuV	dB/m	dB	dB	cm	deg	
1	60.51	32.05	-7.95	40.00	49.78	11.90	2.13	31.76	---	---	Peak
2	91.29	38.31	-5.19	43.50	53.25	14.83	1.95	31.72	100	100	Peak
3	192.81	32.12	-11.38	43.50	46.41	15.48	1.95	31.72	---	---	Peak
4	867.70	30.28	-15.72	46.00	29.39	29.21	3.34	31.66	---	---	Peak
5	918.10	31.28	-14.72	46.00	29.49	29.88	3.27	31.36	---	---	Peak
6	957.30	31.47	-14.53	46.00	28.70	30.70	3.06	30.99	---	---	Peak
7	1960.00	56.76	84.72	26.23	6.31	60.50	---	---	Peak
8	2924.00	36.26	-37.74	74.00	61.14	28.32	7.63	60.83	---	---	Peak
9	4946.00	42.03	-31.97	74.00	58.58	31.42	11.17	59.14	---	---	Peak
10	6926.00	42.02	-31.98	74.00	55.42	35.13	11.78	60.31	---	---	Peak
11	8688.00	44.63	-29.37	74.00	52.96	37.19	14.21	59.73	---	---	Peak
12	10894.00	47.07	-26.93	74.00	51.12	40.42	14.94	59.41	---	---	Peak
13	11166.00	47.16	-26.84	74.00	50.22	40.40	15.41	58.87	100	212	Peak



4. List of Measuring Equipment

Instrument	Manufacturer	Model No.	Serial No.	Characteristics	Calibration Date	Test Date	Due Date	Remark
AC Power Source	ChainTek	APC-1000W	N/A	N/A	N/A	May 22, 2016	N/A	Conduction (CO05-HY)
EMI Test Receiver	Rohde & Schwarz	ESCI 7	100724	9kHz~7GHz	Aug. 26, 2015	May 22, 2016	Aug. 25, 2016	Conduction (CO05-HY)
LISN	Rohde & Schwarz	ENV216	100080	9kHz~30MHz	Dec. 02, 2015	May 22, 2016	Dec. 01, 2016	Conduction (CO05-HY)
Bilog Antenna	Schaffner	CBL6111C	2725	30MHz~1GHz	Nov. 17, 2015	May 22, 2016	Nov. 16, 2016	Radiation (03CH06-HY)
EMI Test Receiver	Rohde & Schwarz	ESU26	100472	20Hz~26.5GHz	Jan. 07, 2016	May 22, 2016	Jan. 06, 2017	Radiation (03CH06-HY)
Horn Antenna	SCHWARZBECK	BBHA 9120 D	9120D-1156	1GHz~18GHz	Aug. 21, 2015	May 22, 2016	Aug. 20, 2016	Radiation (03CH06-HY)
Preamplifier	SONOMA	310N	186713	9kHz~1GHz	Apr. 19, 2016	May 22, 2016	Apr. 18, 2017	Radiation (03CH06-HY)
Preamplifier	MITEQ	AMF-7D-0010 1800-30-10P	1850117	1GHz ~ 18GHz	Jul. 01, 2015	May 22, 2016	Jun. 30, 2016	Radiation (03CH06-HY)
Antenna Mast	MF	MF-7802	MF780208212	1m~4m	N/A	May 22, 2016	N/A	Radiation (03CH06-HY)
Turn Table	INN-CO	DS2000	420/650/00	0-360 degree	N/A	May 22, 2016	N/A	Radiation (03CH06-HY)
Loop Antenna	Rohde & Schwarz	HFH2-Z2	100315	9 kHz~30 MHz	Sep. 02, 2015	May 22, 2016	Sep. 01, 2015	Radiation (03CH06-HY)



5. Uncertainty of Evaluation

Uncertainty of Conducted Emission Measurement (150 kHz ~ 30 MHz)

Measuring Uncertainty for a Level of Confidence of 95% ($U = 2Uc(y)$)	2.26
---	------

Uncertainty of Radiated Emission Measurement (30 MHz ~ 1000 MHz)

Measuring Uncertainty for a Level of Confidence of 95% ($U = 2Uc(y)$)	4.00
---	------



Appendix A. Original Report

Please refer to Sporton report number FV631828 as below.



FCC Test Report

APPLICANT : Motorola Mobility, LLC
EQUIPMENT : Mobile Cellular Phone
BRAND NAME : Motorola
MODEL NAME : 4237
FCC ID : IHDT56VB1
STANDARD : FCC 47 CFR FCC Part 15 Subpart B
CLASSIFICATION : Verification

The product was received on Mar. 18, 2016 and testing was completed on Apr. 13, 2016. We, SPORTON INTERNATIONAL INC., would like to declare that the tested sample has been evaluated in accordance with the test procedures given in ANSI C63.4-2014 and has been in compliance with the applicable technical standards.

The test results in this report apply exclusively to the tested model / sample. Without written approval of SPORTON INTERNATIONAL INC., the test report shall not be reproduced except in full.

Louis Wu

Reviewed by: Louis Wu / Manager

Jones Tsai

Approved by: Jones Tsai / Manager



SPORTON INTERNATIONAL INC.

No. 52, Hwa Ya 1st Rd., Hwa Ya Technology Park, Kwei-Shan District, Tao Yuan City, Taiwan, R.O.C.

SPORTON INTERNATIONAL INC.

TEL : 886-3-327-3456

FAX : 886-3-328-4978

FCC ID : IHDT56VB1

Page Number : 1 of 22

Report Issued Date : May 12, 2016

Report Version : Rev. 01

Report Template No.: BU5-FD15B Version 1.2



TABLE OF CONTENTS

REVISION HISTORY.....3

SUMMARY OF TEST RESULT4

1. GENERAL DESCRIPTION.....5

 1.1. Applicant.....5

 1.2. Manufacturer5

 1.3. Product Feature of Equipment Under Test5

 1.4. Product Specification of Equipment Under Test6

 1.5. Modification of EUT7

 1.6. Test Location.....7

 1.7. Applicable Standards8

2. TEST CONFIGURATION OF EQUIPMENT UNDER TEST.....9

 2.1. Test Mode9

 2.2. Connection Diagram of Test System10

 2.3. Support Unit used in test configuration and system.....12

 2.4. EUT Operation Test Setup.....12

3. TEST RESULT.....13

 3.1. Test of AC Conducted Emission Measurement13

 3.2. Test of Radiated Emission Measurement17

4. LIST OF MEASURING EQUIPMENT21

5. UNCERTAINTY OF EVALUATION.....22



SUMMARY OF TEST RESULT

Report Section	FCC Rule	Description	Limit	Result	Remark
3.1	15.107	AC Conducted Emission	< 15.107 limits	PASS	Under limit 16.40 dB at 0.678 MHz
3.2	15.109	Radiated Emission	< 15.109 limits	PASS	Under limit 4.96 dB at 35.400 MHz



1. General Description

1.1. Applicant

Motorola Mobility, LLC

222 W Merchandise Mart Plaza, Suite 1800, Chicago, IL 60654, United States

1.2. Manufacturer

Motorola Mobility, LLC

222 W Merchandise Mart Plaza, Suite 1800, Chicago, IL 60654, United States

1.3. Product Feature of Equipment Under Test

Product Feature	
Equipment	Mobile Cellular Phone
Brand Name	Motorola
Model Name	4237
FCC ID	IHDT56VB1
IMEI Code	354107070048744
EUT supports Radios application	CDMA/EV-DO/GSM/EGPRS/WCDMA/HSPA/LTE/NFC WLAN 11b/g/n HT20 WLAN 11a/n HT20/HT40 WLAN 11ac VHT20/VHT40/VHT80 Bluetooth v3.0 EDR Bluetooth v4.2 LE
HW Version	DVT2
EUT Stage	Identical Prototype

Remark: The above EUT's information was declared by manufacturer. Please refer to the specifications or user's manual for more detailed description.

Accessory List	
AC Adapter	Brand Name : Motorola
	Model Name : SPN5913A
Earphone	Brand Name : Motorola
	Model Name : SJYN1305A
USB Cable	Brand Name : Motorola
	Model Name : SKN6473A
USB-C to 3.5mm Adapter	Brand Name : Motorola
	Model Name : SKN6474A



1.4. Product Specification of Equipment Under Test

Standards-related Product Specification	
Tx Frequency	GSM850: 824.2 MHz ~ 848.8 MHz GSM1900: 1850.2 MHz ~ 1909.8MHz WCDMA Band V: 826.4 MHz ~ 846.6 MHz WCDMA Band II: 1852.4 MHz ~ 1907.6 MHz CDMA2000 BC0: 824.70 MHz ~ 848.31 MHz CDMA2000 BC1: 1851.25 MHz ~ 1908.75 MHz LTE Band 5 : 824.7 MHz ~ 848.3 MHz LTE Band 2 : 1850.7 MHz ~ 1909.3 MHz LTE Band 4 : 1710.7 MHz ~ 1754.3 MHz LTE Band 7 : 2502.5 MHz ~ 2567.5 MHz LTE Band 13 : 779.5 MHz ~ 784.5 MHz 802.11b/g/n: 2412 MHz ~ 2462 MHz 802.11a/n/ac: 5180 MHz ~ 5240 MHz; 5260 MHz ~ 5320 MHz; 5500 MHz ~ 5700 MHz ; 5745 MHz ~ 5825 MHz Bluetooth: 2402 MHz ~ 2480 MHz NFC : 13.56 MHz
Rx Frequency	GSM850: 869.2 MHz ~ 893.8 MHz GSM1900: 1930.2 MHz ~ 1989.8 MHz WCDMA Band V: 871.4 MHz ~ 891.6 MHz WCDMA Band II: 1932.4 MHz ~ 1987.6 MHz CDMA2000 BC0: 869.70 MHz ~ 893.31 MHz CDMA2000 BC1: 1931.25 MHz ~ 1988.75 MHz LTE Band 5 : 869.7 MHz ~ 893.3 MHz LTE Band 2 : 1930.7 MHz ~ 1989.3 MHz LTE Band 4 : 2110.7 MHz ~ 2154.3 MHz LTE Band 7 : 2622.5MHz ~ 2687.5 MHz LTE Band 13 : 748.5 MHz ~ 753.5 MHz 802.11b/g/n: 2412 MHz ~ 2462 MHz 802.11a/n/ac: 5180 MHz ~ 5240 MHz; 5260 MHz ~ 5320 MHz; 5500 MHz ~ 5700 MHz ; 5745 MHz ~ 5825 MHz Bluetooth: 2402 MHz ~ 2480 MHz GPS : 1.57542 GHz NFC : 13.56 MHz
Antenna Type	WWAN : Fixed Internal Antenna WLAN : Fixed Internal Antenna Bluetooth : Fixed Internal Antenna GPS : Fixed Internal Antenna NFC: Fixed Internal Antenna

Standards-related Product Specification	
Type of Modulation	GSM: GMSK GPRS: GMSK EDGE(MCS 0-4): GMSK / (MCS 5-9): 8PSK WCDMA: QPSK (Uplink) HSDPA: QPSK (Downlink) HSUPA: QPSK (Uplink) CDMA2000 : QPSK CDMA2000 1xEV-DO : 8PSK LTE: QPSK / 16QAM 802.11b : DSSS (DBPSK / DQPSK / CCK) 802.11a/g/n : OFDM (BPSK / QPSK / 16QAM / 64QAM) 802.11ac : OFDM (BPSK / QPSK / 16QAM / 64QAM /256QAM) Bluetooth LE : GFSK Bluetooth (1Mbps) : GFSK Bluetooth (2Mbps) : $\pi/4$ -DQPSK Bluetooth (3Mbps) : 8-DPSK GPS : BPSK NFC: ASK

1.5. Modification of EUT

No modifications are made to the EUT during all test items.

1.6. Test Location

Sporton Lab is accredited to ISO 17025 by Taiwan Accreditation Foundation (TAF code : 1190) and the FCC designation No. TW1022 under the FCC 2.948(e) by Mutual Recognition Agreement (MRA) in FCC Test.

Test Site	SPORTON INTERNATIONAL INC.	
Test Site Location	No. 52, Hwa Ya 1 st Rd., Hwa Ya Technology Park, Kwei-Shan District, Tao Yuan City, Taiwan, R.O.C. TEL: +886-3-327-3456 FAX: +886-3-328-4978	
Test Site No.	Sporton Site No.	
	CO05-HY	03CH06-HY



1.7. Applicable Standards

According to the specifications of the manufacturer, the EUT must comply with the requirements of the following standards:

- ♦ FCC 47 CFR FCC Part 15 Subpart B
- ♦ ANSI C63.4-2014

Remark:

1. All test items were verified and recorded according to the standards and without any deviation during the test.
2. For FCC 15 Subpart B - Unintentional Radiators, receivers contained within a transceiver shall be authorized under the verification procedure per the Section 15.101 (b).
3. For other Unintentional Radiators features of this EUT, test reports are be issued separately.
Per the Note of the Section 15.101, when device supports features (USB, FM Radio, digital devices...etc) more than one category of authorization, type of authorization shall be appropriately chosen for FCC 15B compliance rule, and the Section 15.101 (b), only those receivers that operate (tune) within the frequency range of 30-960 MHz, CB receivers and radar detectors are subject to the authorizations shown in paragraph (a) of the Section 15.101. However, receivers indicated as being subject to Declaration of Conformity that are contained within a transceiver, the transmitter portion of which is subject to certification, shall be authorized under the verification procedure.
4. Receivers operating above 960 MHz or below 30 MHz, except for radar detectors and CB receivers, are exempt from complying with the technical provisions of this part but are subject to § 15.5.



2. Test Configuration of Equipment Under Test

2.1. Test Mode

The EUT has been associated with peripherals pursuant to ANSI C63.4-2014 and configuration operated in a manner tended to maximize its emission characteristics in a typical application.

Frequency range investigated: conduction (150 kHz to 30 MHz), radiation (30MHz to the 5th harmonic of the highest fundamental frequency or to 40 GHz, whichever is lower).

The following tables are showing the test modes as the worst cases and recorded in this report.

Item	EUT Configuration	Test Condition		
		EMI AC	EMI RE<1G	EMI RE≥1G
1.	Charging Mode (EUT with adapter)	☒	☒	☒

Abbreviations:

- EMI AC: AC conducted emissions
- EMI RE ≥ 1G: EUT radiated emissions ≥ 1GHz
- EMI RE < 1G: EUT radiated emissions < 1GHz

Test Items	EUT Configure Mode	Function Type
AC Conducted Emission	1	Mode 1: GSM1900 Idle + Bluetooth Idle + WLAN Idle + MP3 + Battery + USB Cable (Charging from Adapter) Mode 2: WCDMA Band V Idle + Bluetooth Idle + WLAN Idle + Camera + Battery + USB Cable (Charging from Adapter)
Radiated Emissions < 1GHz	1	Mode 1: GSM1900 Idle + Bluetooth Idle + WLAN Idle + MP3 + Earphone + Battery + USB -C to 3.5mm Adapter) Mode 2: WCDMA Band V Idle + Bluetooth Idle + WLAN Idle + Camera + Battery + USB Cable (Charging from Adapter)
Radiated Emissions ≥ 1GHz	1	Mode 1: WCDMA Band V Idle + Bluetooth Idle + WLAN Idle + Camera + Battery + USB Cable (Charging from Adapter)

Remark:

1. The worst case of AC is mode 2; only the test data of this mode was reported.
2. The worst case of RE < 1G is mode 2; only the test data of this mode was reported.

2.2. Connection Diagram of Test System

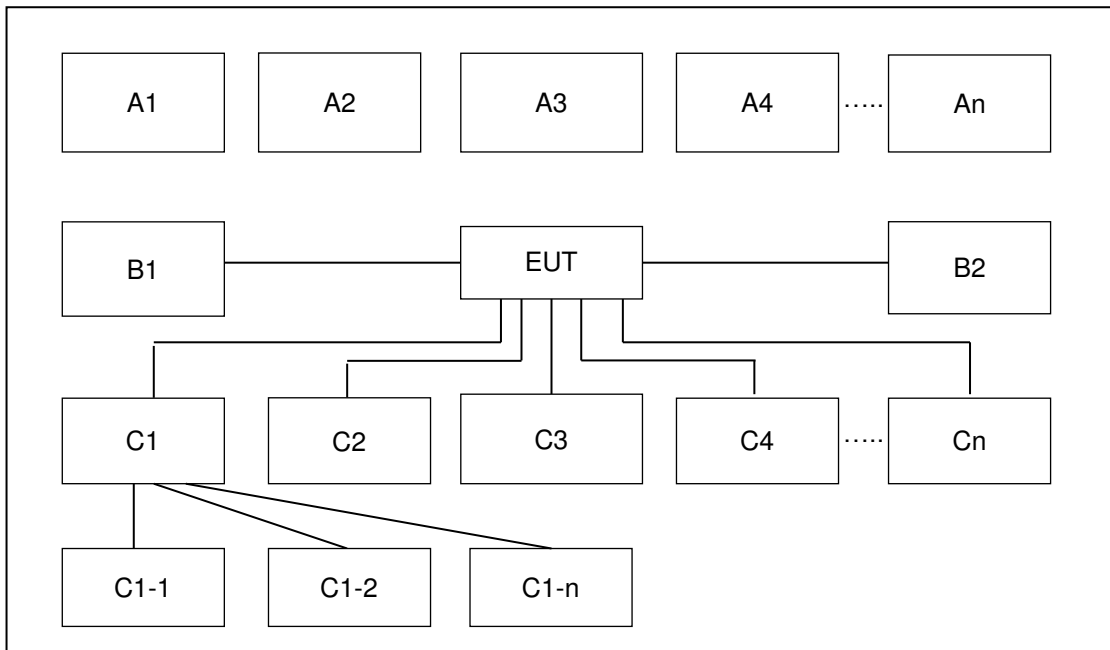

Radiation Test Setup									
No.	Wireless Station	Connection Type	Test Mode						
			1	2	-	-	-	-	-
A1	BT Earphone	Bluetooth	X	X					
A2	System Simulator	GSM/UMTS	X	X					
A3	AP router	WiFi	X	X					
No.	Power Source	Connection Type	1	2	-	-	-	-	-
B1	AC : 120V/60Hz	AC Power Cable		X					
No.	Setup Peripherals	Connection Type	1	2	-	-	-	-	-
C1	Earphone	Earphone jack	X						
C2	SD card	SD I/O interface without cable	X	X					



Conduction Test Setup									
No.	Wireless Station	Connection Type	Test Mode						
			1	2	-	-	-	-	-
A1	BT Earphone	Bluetooth	X	X					
A2	System Simulator	GSM/UMTS	X	X					
A3	AP router	WiFi	X	X					
No.	Power Source	Connection Type	1	2	-	-	-	-	-
B1	AC : 120V/60Hz	AC Power Cable	X	X					
No.	Setup Peripherals	Connection Type	1	2	-	-	-	-	-
C1	SD card	SD I/O interface without Cable	X	X					



2.3. Support Unit used in test configuration and system

Item	Equipment	Trade Name	Model Name	FCC ID	Data Cable	Power Cord
1.	System Simulator	R&S	CMU 200	N/A	N/A	Unshielded, 1.8 m
2.	System Simulator	Anritsu	MT8820C	N/A	N/A	Unshielded, 1.8 m
3.	WLAN AP	D-Link	DIR-628	KA2DIR628A2	N/A	Unshielded, 1.8 m
4.	WLAN AP	D-Link	DIR-865L	KA2IR865LA1	N/A	Unshielded, 1.8 m
5.	Bluetooth Earphone	Sony Ericsson	MW600	PY7DDA-2029	N/A	N/A
6.	SD Card	SanDisk	MicroSD HC	FCC DoC	N/A	N/A

2.4. EUT Operation Test Setup

The EUT was in GSM or WCDMA idle mode during the testing. The EUT was synchronized to the BCCH, and is in continuous receiving mode by setting system simulator’s paging reorganization.

The EUT was attached to the Bluetooth earphone or WLAN AP, and the following programs installed in the EUT were programmed during the test.

1. Execute “Music Player” to play MP3 file.
2. Turn on camera to capture images.



3. Test Result

3.1. Test of AC Conducted Emission Measurement

3.1.1 Limits of AC Conducted Emission

For equipment that is designed to be connected to the public utility (AC) power line, the radio frequency voltage that is conducted back onto the AC power line on any frequency or frequencies within the band 150 kHz to 30 MHz shall not exceed the limits in the following table.

Frequency of emission (MHz)	Conducted limit (dBuV)	
	Quasi-peak	Average
0.15-0.5	66 to 56*	56 to 46*
0.5-5	56	46
5-30	60	50

*Decreases with the logarithm of the frequency.

3.1.2 Measuring Instruments

The measuring equipment is listed in the section 4 of this test report.

3.1.3 Test Procedure

1. The EUT was placed 0.4 meter from the conducting wall of the shielding room was kept at least 80 centimeters from any other grounded conducting surface.
2. Connect EUT to the power mains through a line impedance stabilization network (LISN).
3. All the support units are connecting to the other LISN.
4. The LISN provides 50 ohm coupling impedance for the measuring instrument.
5. The FCC states that a 50 ohm, 50 microhenry LISN should be used.
6. Both sides of AC line were checked for maximum conducted interference.
7. The frequency range from 150 kHz to 30 MHz was searched.
8. Set the test-receiver system to Peak Detect Function and specified bandwidth (IF Bandwidth = 9kHz) with Maximum Hold Mode. Then measurement is also conducted by Average Detector and Quasi-Peak Detector Function respectively.

3.1.4 Test Setup

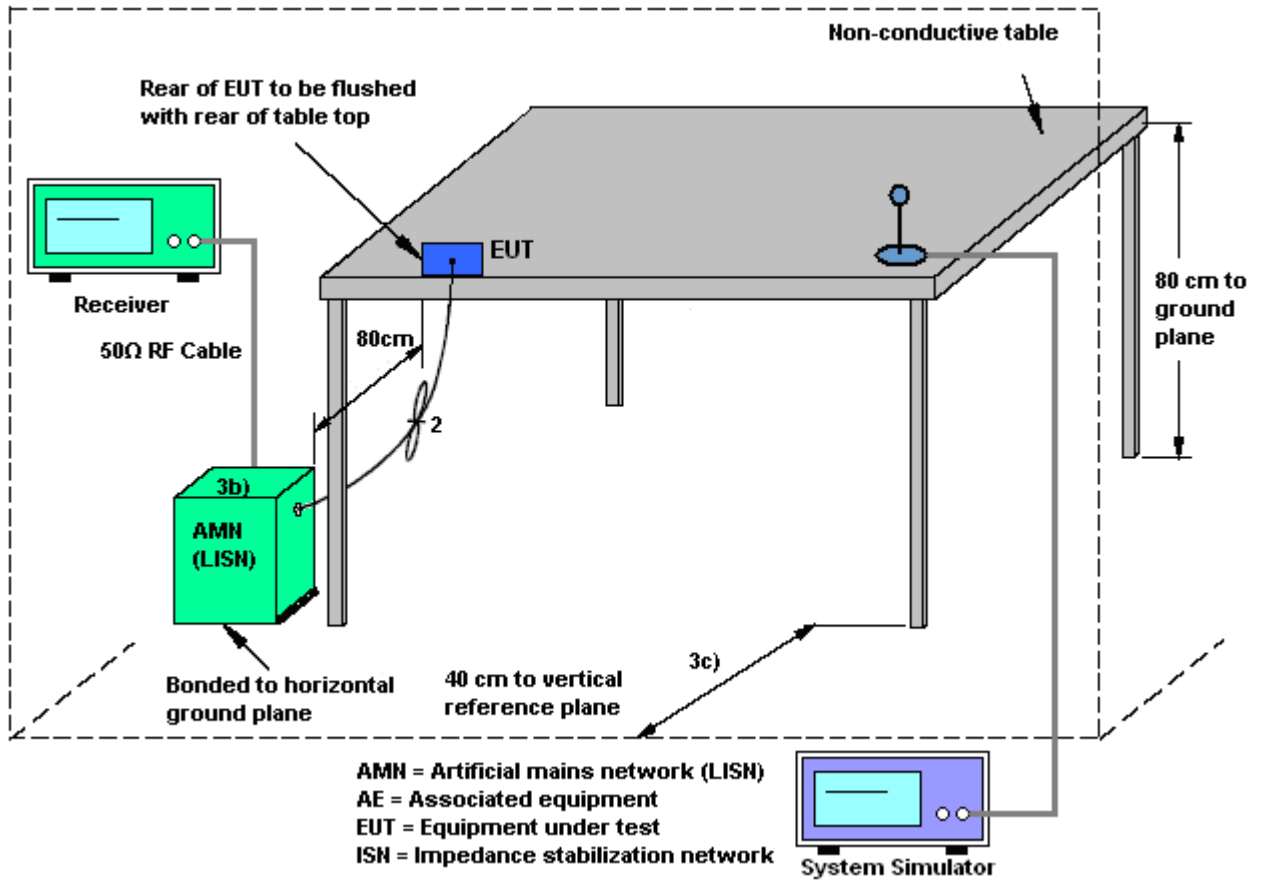

3.1.5 Test Result of AC Conducted Emission

Test Mode :	Mode 2	Temperature :	23~24°C
Test Engineer :	Kai-Chun Chu	Relative Humidity :	53~54%
Test Voltage :	120Vac / 60Hz	Phase :	Line
Function Type :	WCDMA Band V Idle + Bluetooth Idle + WLAN Idle + Camera + Battery + USB Cable (Charging from Adapter)		

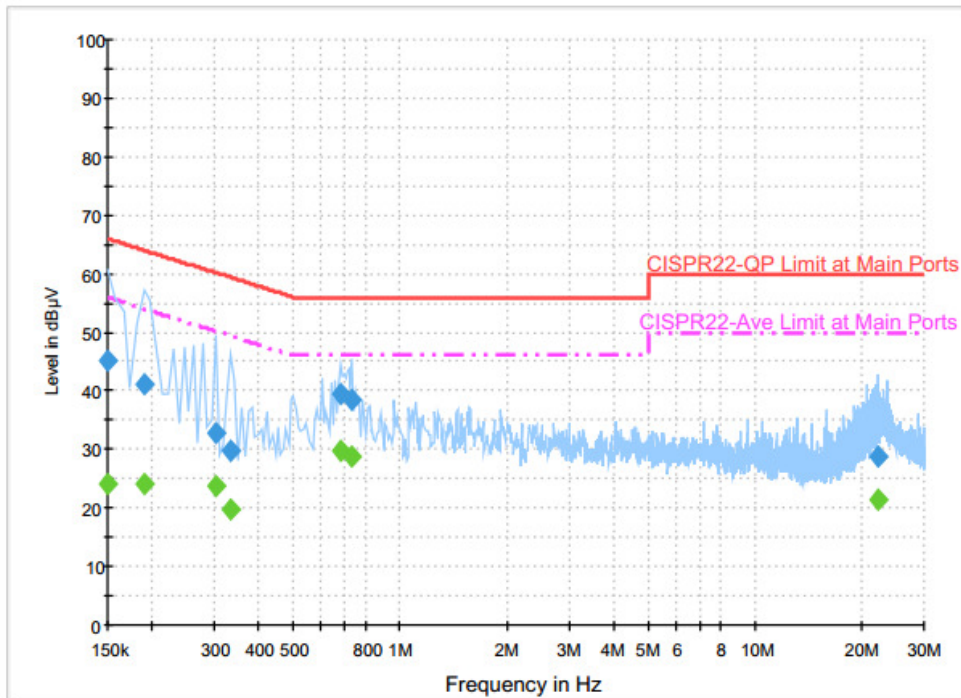

Final Result : Quasi-Peak

Frequency (MHz)	Quasi-Peak (dBµV)	Filter	Line	Corr. (dB)	Margin (dB)	Limit (dBµV)
0.150000	45.0	Off	L1	19.6	21.0	66.0
0.190000	41.1	Off	L1	19.6	22.9	64.0
0.302000	32.8	Off	L1	19.6	27.4	60.2
0.334000	29.8	Off	L1	19.6	29.6	59.4
0.678000	39.6	Off	L1	19.6	16.4	56.0
0.734000	38.5	Off	L1	19.6	17.5	56.0
22.206000	28.8	Off	L1	19.8	31.2	60.0

Final Result : Average

Frequency (MHz)	Average (dBµV)	Filter	Line	Corr. (dB)	Margin (dB)	Limit (dBµV)
0.150000	24.1	Off	L1	19.6	31.9	56.0
0.190000	24.2	Off	L1	19.6	29.8	54.0
0.302000	23.6	Off	L1	19.6	26.6	50.2
0.334000	19.6	Off	L1	19.6	29.8	49.4
0.678000	29.6	Off	L1	19.6	16.4	46.0
0.734000	28.6	Off	L1	19.6	17.4	46.0
22.206000	21.5	Off	L1	19.8	28.5	50.0

Test Mode :	Mode 2	Temperature :	23~24°C
Test Engineer :	Kai-Chun Chu	Relative Humidity :	53~54%
Test Voltage :	120Vac / 60Hz	Phase :	Neutral
Function Type :	WCDMA Band V Idle + Bluetooth Idle + WLAN Idle + Camera + Battery + USB Cable (Charging from Adapter)		

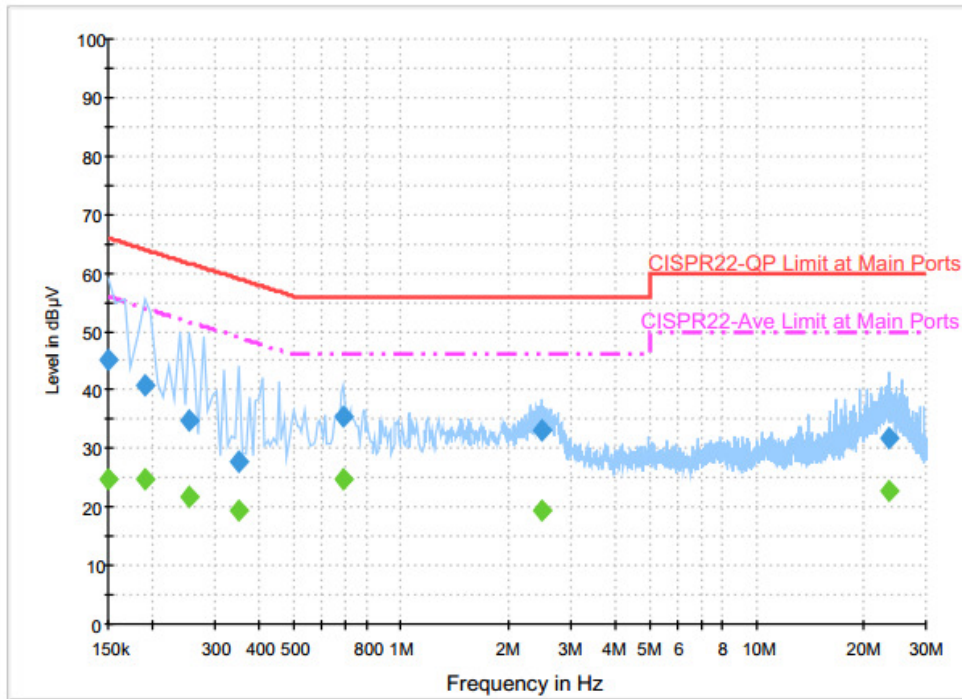

Final Result : Quasi-Peak

Frequency (MHz)	Quasi-Peak (dBµV)	Filter	Line	Corr. (dB)	Margin (dB)	Limit (dBµV)
0.150000	45.1	Off	N	19.6	20.9	66.0
0.190000	40.8	Off	N	19.6	23.2	64.0
0.254000	34.7	Off	N	19.6	26.9	61.6
0.350000	27.8	Off	N	19.6	31.2	59.0
0.686000	35.6	Off	N	19.6	20.4	56.0
2.478000	33.0	Off	N	19.6	23.0	56.0
23.774000	31.7	Off	N	20.0	28.3	60.0

Final Result : Average

Frequency (MHz)	Average (dBµV)	Filter	Line	Corr. (dB)	Margin (dB)	Limit (dBµV)
0.150000	24.6	Off	N	19.6	31.4	56.0
0.190000	24.8	Off	N	19.6	29.2	54.0
0.254000	21.6	Off	N	19.6	30.0	51.6
0.350000	19.3	Off	N	19.6	29.7	49.0
0.686000	24.6	Off	N	19.6	21.4	46.0
2.478000	19.5	Off	N	19.6	26.5	46.0
23.774000	22.9	Off	N	20.0	27.1	50.0



3.2. Test of Radiated Emission Measurement

3.2.1. Limit of Radiated Emission

The emissions from an unintentional radiator shall not exceed the field strength levels specified in the following table:

Frequency (MHz)	Field Strength (microvolts/meter)	Measurement Distance (meters)
30 – 88	100	3
88 – 216	150	3
216 - 960	200	3
Above 960	500	3

3.2.2. Measuring Instruments

The measuring equipment is listed in the section 4 of this test report.

3.2.3. Test Procedures

1. The EUT was placed on a turntable with 0.8 meter above ground.
2. The EUT was set 3 meters from the interference receiving antenna, which was mounted on the top of a variable height antenna tower.
3. The table was rotated 360 degrees to determine the position of the highest radiation.
4. The antenna is a Bi-Log antenna and its height is adjusted between one to four meters above ground to find the maximum value of the field strength for both horizontal polarization and vertical polarization of the antenna.
5. For each suspected emission, the EUT was arranged to its worst case and then tune the antenna tower (from 1 m to 4 m) and turntable (from 0 degree to 360 degrees) to find the maximum reading.
6. Set the test-receiver system to Peak Detect Function and specified bandwidth with Maximum Hold Mode (RBW=120kHz/VBW=300kHz for frequency below 1GHz; RBW=1MHz VBW=3MHz (Peak), RBW=1MHz/VBW=10Hz (Average) for frequency above 1GHz).
7. If the emission level of the EUT in peak mode was 3 dB lower than the limit specified, peak values of EUT will be reported. Otherwise, the emission will be repeated by using the quasi-peak method and reported.
8. Emission level (dBµV/m) = 20 log Emission level (µV/m)
9. Corrected Reading: Antenna Factor + Cable Loss + Read Level - Preamp Factor = Level

3.2.4. Test Setup of Radiated Emission

For radiated emissions from 30MHz to 1GHz

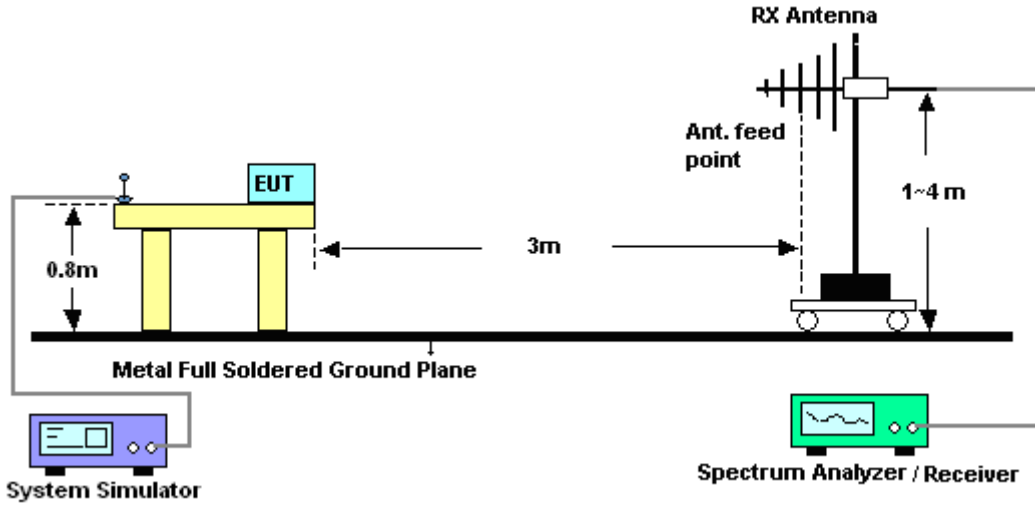

For radiated emissions above 1GHz

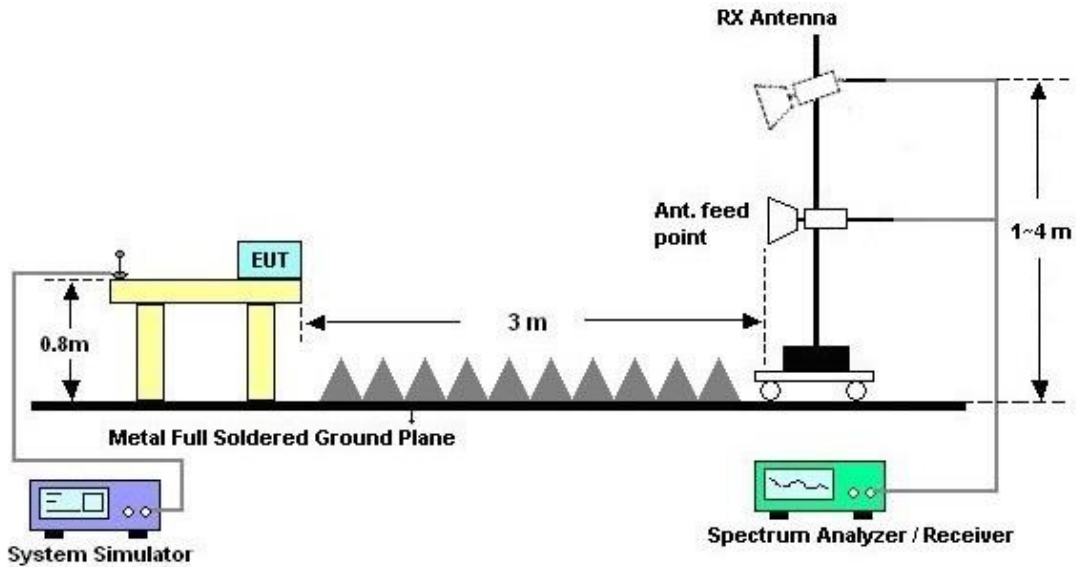



3.2.5. Test Result of Radiated Emission

Test Mode :	Mode 2	Temperature :	20~23°C
Test Engineer :	Donny Tang	Relative Humidity :	50~53%
Test Distance :	3m	Polarization :	Horizontal
Function Type :	WCDMA Band V Idle + Bluetooth Idle + WLAN Idle + Camera + Battery + USB Cable (Charging from Adapter)		
Remark :	#5 is system simulator signal which can be ignored.		

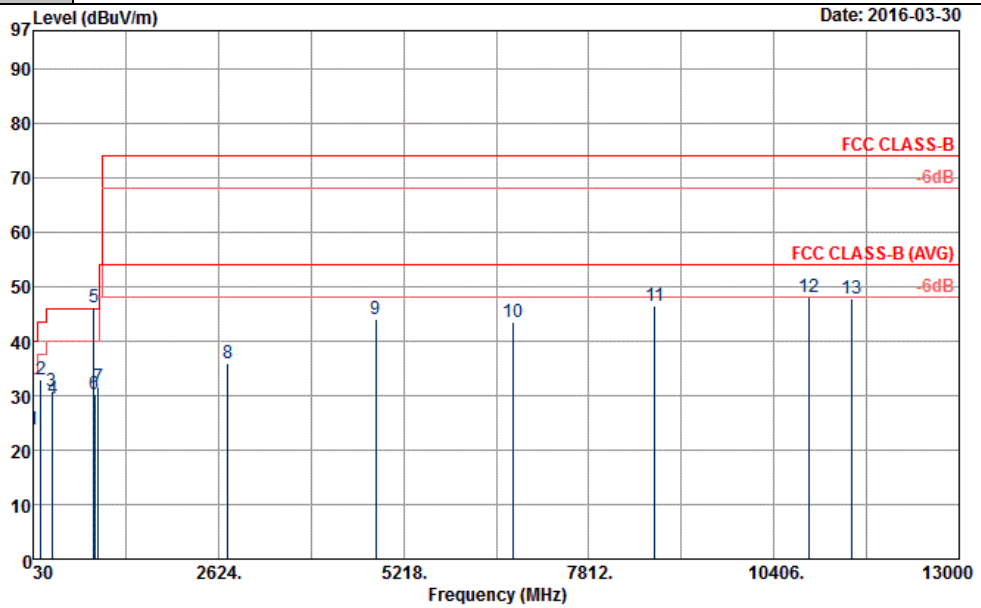

Site : 03CH06-HY
 Condition : FCC CLASS-B 3m 9120D_1156_150827 HORIZONTAL

Power : 120Vac/60Hz
 Memo : Mode 2

	Freq	Level	Over Limit	Limit Line	ReadAntenna Level	Cable Factor	Preamp Factor	A/Pos	T/Pos	Remark	
	MHz	dBUV/m	dB	dBUV/m	dBUV	dB/m	dB	dB	cm	deg	
1	31.35	23.87	-16.13	40.00	28.61	25.14	1.90	31.78	---	---	Peak
2	141.51	33.05	-10.45	43.50	44.85	17.81	2.12	31.73	100	222	Peak
3	297.57	30.74	-15.26	46.00	40.66	19.50	2.28	31.70	---	---	Peak
4	300.00	29.35	-16.65	46.00	39.27	19.50	2.28	31.70	---	---	Peak
5 *	881.60	46.17			45.07	29.29	3.36	31.55	---	---	Peak
6	888.00	30.39	-15.61	46.00	29.21	29.33	3.37	31.52	---	---	Peak
7	941.20	31.51	-14.49	46.00	29.03	30.47	3.11	31.10	---	---	Peak
8	2760.00	36.00	-38.00	74.00	61.26	27.99	7.46	60.71	---	---	Peak
9	4832.00	44.04	-29.96	74.00	61.50	31.22	11.01	59.69	---	---	Peak
10	6756.00	43.44	-30.56	74.00	57.21	34.72	11.86	60.35	---	---	Peak
11	8736.00	46.43	-27.57	74.00	54.63	37.27	14.35	59.82	---	---	Peak
12	10906.00	48.19	-25.81	74.00	52.18	40.43	14.94	59.36	100	106	Peak
13	11494.00	47.87	-26.13	74.00	50.13	40.21	15.95	58.42	---	---	Peak



Test Mode :	Mode 2	Temperature :	20~23°C
Test Engineer :	Donny Tang	Relative Humidity :	50~53%
Test Distance :	3m	Polarization :	Vertical
Function Type :	WCDMA Band V Idle + Bluetooth Idle + WLAN Idle + Camera + Battery + USB Cable (Charging from Adapter)		
Remark :	#5 is system simulator signal which can be ignored.		

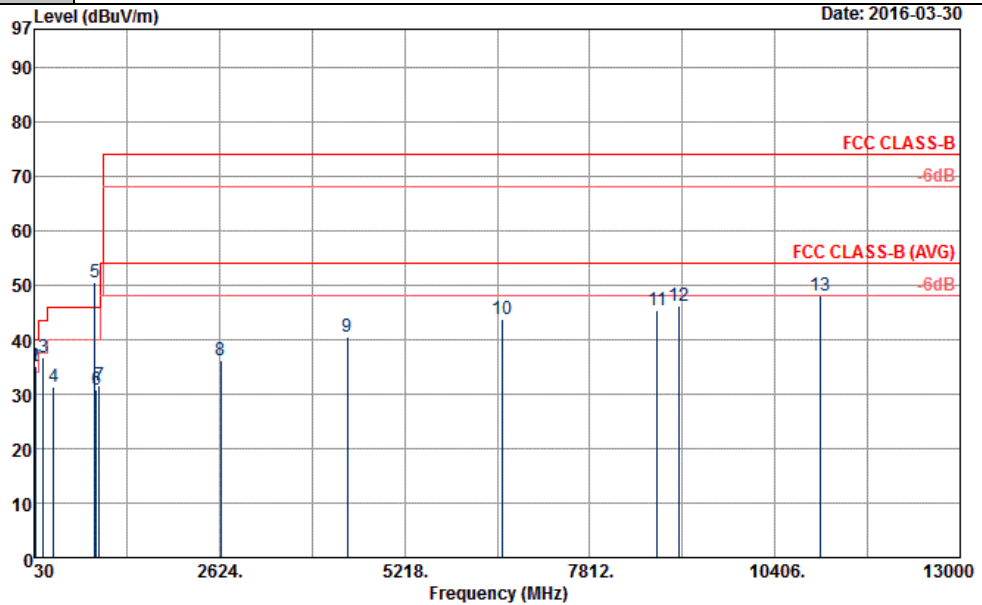

Site : 03CH06-HY
 Condition : FCC CLASS-B 3m 9120D_1156_150827 VERTICAL
 Power : 120Vac/60Hz
 Memo : Mode 2

	Freq	Level	Over Limit	Limit Line	ReadAntenna Level	Cable Factor	Preamp Loss	A/Pos	T/Pos	Remark	
	MHz	dBuV/m	dB	dBuV/m	dBuV	dB/m	dB	cm	deg		
1	35.40	35.04	-4.96	40.00	42.58	22.32	1.92	31.78	100	136 Peak	
2	41.61	35.01	-4.99	40.00	46.16	18.88	1.75	31.78	---	---	Peak
3	159.60	36.86	-6.64	43.50	49.76	16.70	2.13	31.73	---	---	Peak
4	301.40	31.31	-14.69	46.00	41.17	19.56	2.28	31.70	---	---	Peak
5 *	881.60	50.59			49.49	29.29	3.36	31.55	---	---	Peak
6	902.00	30.79	-15.21	46.00	29.40	29.45	3.38	31.44	---	---	Peak
7	944.00	31.62	-14.38	46.00	29.05	30.55	3.09	31.07	---	---	Peak
8	2644.00	36.18	-37.82	74.00	61.79	27.73	7.28	60.62	---	---	Peak
9	4422.00	40.64	-33.36	74.00	60.53	30.53	10.83	61.25	---	---	Peak
10	6582.00	43.84	-30.16	74.00	57.62	34.27	12.34	60.39	---	---	Peak
11	8758.00	45.46	-28.54	74.00	53.53	37.30	14.48	59.85	---	---	Peak
12	9060.00	46.24	-27.76	74.00	54.70	37.81	14.11	60.38	---	---	Peak
13	11050.00	47.98	-26.02	74.00	51.33	40.47	15.21	59.03	100	98 Peak	



4. List of Measuring Equipment

Instrument	Manufacturer	Model No.	Serial No.	Characteristics	Calibration Date	Test Date	Due Date	Remark
AC Power Source	ChainTek	APC-1000W	N/A	N/A	N/A	Mar. 31, 2016	N/A	Conduction (CO05-HY)
EMI Test Receiver	Rohde & Schwarz	ESCI 7	100724	9kHz~7GHz	Aug. 26, 2015	Mar. 31, 2016	Aug. 25, 2016	Conduction (CO05-HY)
LISN	Rohde & Schwarz	ENV216	100080	9kHz~30MHz	Dec. 02, 2015	Mar. 31, 2016	Dec. 01, 2016	Conduction (CO05-HY)
Bilog Antenna	Schaffner	CBL6111C	2725	30MHz~1GHz	Nov. 17, 2015	Mar. 30, 2016 ~ Apr. 13, 2016	Nov. 16, 2016	Radiation (03CH06-HY)
EMI Test Receiver	Rohde & Schwarz	ESU26	100472	20Hz~26.5GHz	Jan. 07, 2016	Mar. 30, 2016 ~ Apr. 13, 2016	Jan. 06, 2017	Radiation (03CH06-HY)
Horn Antenna	SCHWARZBECK	BBHA 9120 D	9120D-1156	1GHz~18GHz	Aug. 21, 2015	Mar. 30, 2016 ~ Apr. 13, 2016	Aug. 20, 2016	Radiation (03CH06-HY)
Preamplifier	SONOMA	310N	186713	9kHz~1GHz	Apr. 20, 2015	Mar. 30, 2016 ~ Apr. 13, 2016	Apr. 19, 2016	Radiation (03CH06-HY)
Preamplifier	MITEQ	AMF-7D-0010 1800-30-10P	1850117	1GHz ~ 18GHz	Jul. 01, 2015	Mar. 30, 2016 ~ Apr. 13, 2016	Jun. 30, 2016	Radiation (03CH06-HY)
Antenna Mast	MF	MF-7802	MF780208212	1m~4m	N/A	Mar. 30, 2016 ~ Apr. 13, 2016	N/A	Radiation (03CH06-HY)
Turn Table	INN-CO	DS2000	420/650/00	0-360 degree	N/A	Mar. 30, 2016 ~ Apr. 13, 2016	N/A	Radiation (03CH06-HY)
Loop Antenna	Rohde & Schwarz	HFH2-Z2	100315	9 kHz~30 MHz	Sep. 02, 2015	Mar. 30, 2016 ~ Apr. 13, 2016	Sep. 01, 2016	Radiation (03CH06-HY)



5. Uncertainty of Evaluation

Uncertainty of Conducted Emission Measurement (150 kHz ~ 30 MHz)

Measuring Uncertainty for a Level of Confidence of 95% ($U = 2Uc(y)$)	2.26
---	------

Uncertainty of Radiated Emission Measurement (30 MHz ~ 1000 MHz)

Measuring Uncertainty for a Level of Confidence of 95% ($U = 2Uc(y)$)	4.00
---	------