



FCC RF Test Report

APPLICANT : Motorola Mobility, LLC
EQUIPMENT : Mobile Cellular Phone
BRAND NAME : Motorola
MODEL NAME : 4237
FCC ID : IHDT56VB1
STANDARD : FCC Part 15 Subpart C §15.247
CLASSIFICATION : (DTS) Digital Transmission System

The product was received on Mar. 18, 2016 and testing was completed on Apr. 25, 2016. We, SPORTON INTERNATIONAL INC., would like to declare that the tested sample has been evaluated in accordance with the test procedures and has been in compliance with the applicable technical standards.

The test results in this report apply exclusively to the tested model / sample. Without written approval of SPORTON INTERNATIONAL INC., the test report shall not be reproduced except in full.

Reviewed by: Joseph Lin / Supervisor

Approved by: Jones Tsai / Manager



SPORTON INTERNATIONAL INC.

No. 52, Hwa Ya 1st Rd., Hwa Ya Technology Park, Kwei-Shan District, Tao Yuan City, Taiwan, R.O.C.

SPORTON INTERNATIONAL INC.

TEL : 886-3-327-3456

FAX : 886-3-328-4978

FCC ID : IHDT56VB1

Page Number : 1 of 84

Report Issued Date : May 10, 2016

Report Version : Rev. 01

Report Template No.: BU5-FR15CWLAC MA Version 1.3



TABLE OF CONTENTS

REVISION HISTORY 3

SUMMARY OF TEST RESULT 4

1 GENERAL DESCRIPTION 5

 1.1 Applicant 5

 1.2 Manufacturer 5

 1.3 Product Feature of Equipment Under Test 5

 1.4 Product Specification of Equipment Under Test 6

 1.5 Modification of EUT 6

 1.6 Testing Location 7

 1.7 Applicable Standards 8

2 TEST CONFIGURATION OF EQUIPMENT UNDER TEST 9

 2.1 Carrier Frequency and Channel 9

 2.2 Pre-Scanned RF Power 10

 2.3 Test Mode 16

 2.4 Connection Diagram of Test System 17

 2.5 Support Unit used in test configuration and system 18

 2.6 EUT Operation Test Setup 18

 2.7 Measurement Results Explanation Example 18

3 TEST RESULT 19

 3.1 6dB and 99% Bandwidth Measurement 19

 3.2 Peak Output Power Measurement 21

 3.3 Power Spectral Density Measurement 22

 3.4 Conducted Band Edges and Spurious Emission Measurement 25

 3.5 Radiated Band Edges and Spurious Emission Measurement 74

 3.6 AC Conducted Emission Measurement 78

 3.7 Antenna Requirements 82

4 LIST OF MEASURING EQUIPMENT 83

5 UNCERTAINTY OF EVALUATION 84

APPENDIX A. CONDUCTED TEST RESULTS

APPENDIX B. RADIATED SPURIOUS EMISSION

APPENDIX C. RADIATED SPURIOUS EMISSION PLOT

APPENDIX D. DUTY CYCLE PLOTS



SUMMARY OF TEST RESULT

Report Section	FCC Rule	Description	Limit	Result	Remark
3.1	15.247(a)(2)	6dB Bandwidth	$\geq 0.5\text{MHz}$	Pass	-
3.1	-	99% Bandwidth	-	Pass	-
3.2	15.247(b)	Power Output Measurement	$\leq 30\text{dBm}$	Pass	-
3.3	15.247(e)	Power Spectral Density	$\leq 8\text{dBm}/3\text{kHz}$	Pass	-
3.4	15.247(d)	Conducted Band Edges	$\leq 20\text{dBc}$	Pass	-
		Conducted Spurious Emission		Pass	-
3.5	15.247(d)	Radiated Band Edges and Radiated Spurious Emission	15.209(a) & 15.247(d)	Pass	Under limit 0.25 dB at 2487.000 MHz
3.6	15.207	AC Conducted Emission	15.207(a)	Pass	Under limit 20.10 dB at 0.150 MHz
3.7	15.203 & 15.247(b)	Antenna Requirement	N/A	Pass	-



1 General Description

1.1 Applicant

Motorola Mobility, LLC

222 W Merchandise Mart Plaza, Suite 1800, Chicago, IL 60654, United States

1.2 Manufacturer

Motorola Mobility, LLC

222 W Merchandise Mart Plaza, Suite 1800, Chicago, IL 60654, United States

1.3 Product Feature of Equipment Under Test

Product Feature	
Equipment	Mobile Cellular Phone
Brand Name	Motorola
Model Name	4237
FCC ID	IHDT56VB1
IMEI Code	354107070048983 (for Radiation) 354107070048744 (for Conduction)
EUT supports Radios application	CDMA/EV-DO/GSM/EGPRS/WCDMA/HSPA/LTE/NFC 2.4GHz WLAN 11b/g/n HT20 WLAN 11ac VHT20 5GHz WLAN 11a/n HT20/HT40 WLAN 11ac VHT20/VHT40/VHT80 Bluetooth v3.0 EDR Bluetooth v4.2 LE
HW Version	DVT2
EUT Stage	Identical Prototype

Remark: The above EUT's information was declared by manufacturer. Please refer to the specifications or user's manual for more detailed description.

Accessory List	
AC Adapter	Brand Name : Motorola
	Model Name : SPN5913A



1.4 Product Specification of Equipment Under Test

Standards-related Product Specification										
Tx/Rx Channel Frequency Range	802.11b/g/n/ac : 2412 MHz ~ 2462 MHz									
Maximum Output Power to antenna	<p><SISO Ant. 1> 802.11b : 18.91 dBm (0.0778 W) 802.11g : 17.30 dBm (0.0537 W) 802.11n HT20 : 16.81 dBm (0.0480 W) 802.11ac VHT20 : 16.75 dBm (0.0473 W)</p> <p><SISO Ant. 2> 802.11b : 14.96 dBm (0.0313 W) 802.11g : 17.73 dBm (0.0593 W) 802.11n HT20 : 13.58 dBm (0.0228 W) 802.11ac VHT20 : 13.59 dBm (0.0229 W)</p> <p><MIMO Ant. 1+2> 802.11b : 19.80 dBm (0.0955 W) 802.11g : 18.18 dBm (0.0658 W) 802.11n HT20 : 17.77 dBm (0.0598 W) 802.11ac VHT20 : 17.77 dBm (0.0598 W)</p>									
99% Occupied Bandwidth	802.11b : 14.65MHz 802.11g : 17.35MHz 802.11n HT20 : 18.35MHz 802.11ac VHT20 : 18.40MHz									
Antenna Type	802.11b/g/n/ac : Fixed Internal Antenna type (The antenna peak gain of EUT is less than 6 dBi)									
Type of Modulation	802.11b : DSSS (DBPSK / DQPSK / CCK) 802.11g/n : OFDM (BPSK / QPSK / 16QAM / 64QAM) 802.11ac : OFDM (BPSK / QPSK / 16QAM / 64QAM / 256QAM)									
Antenna Function for Transmitter	<table border="1"> <thead> <tr> <th></th> <th>Ant. 1</th> <th>Ant. 2</th> </tr> </thead> <tbody> <tr> <td>802.11 b/g/n/ac SISO</td> <td>V</td> <td>V</td> </tr> <tr> <td>802.11 b/g/n/ac MIMO</td> <td>V</td> <td>V</td> </tr> </tbody> </table>		Ant. 1	Ant. 2	802.11 b/g/n/ac SISO	V	V	802.11 b/g/n/ac MIMO	V	V
	Ant. 1	Ant. 2								
802.11 b/g/n/ac SISO	V	V								
802.11 b/g/n/ac MIMO	V	V								

1.5 Modification of EUT

No modifications are made to the EUT during all test items.



1.6 Testing Location

Sporton Lab is accredited to ISO 17025 by Taiwan Accreditation Foundation (TAF code : 1190) and the FCC designation No. TW1022 under the FCC 2.948(e) by Mutual Recognition Agreement (MRA) in FCC Test.

Test Site	SPORTON INTERNATIONAL INC.	
Test Site Location	No. 52, Hwa Ya 1 st Rd., Hwa Ya Technology Park, Kwei-Shan District, Tao Yuan City, Taiwan, R.O.C. TEL: +886-3-327-3456 FAX: +886-3-328-4978	
Test Site No.	Sporton Site No.	
	TH02-HY	CO05-HY

Note: The test site complies with ANSI C63.4 2014 requirement.

Test Site	SPORTON INTERNATIONAL INC.	
Test Site Location	No.58, Aly. 75, Ln. 564, Wenhua 3rd Rd. Guishan Dist, Taoyuan City, Taiwan (R.O.C.) TEL: +886-3-327-0868 FAX: +886-3-327-0855	
Test Site No.	Sporton Site No.	
	03CH11-HY	

Note: The test site complies with ANSI C63.4 2014 requirement.



1.7 Applicable Standards

According to the specifications of the manufacturer, the EUT must comply with the requirements of the following standards:

- ♦ FCC Part 15 Subpart C §15.247
- ♦ FCC KDB Publication No. 558074 D01 DTS Meas. Guidance v03r05
- ♦ FCC KDB 662911 D01 Multiple Transmitter Output v02r01.
- ♦ FCC KDB 644545 D03 Guidance for IEEE 802.11ac New Rules v01
- ♦ ANSI C63.10-2013

Remark:

1. All test items were verified and recorded according to the standards and without any deviation during the test.
2. This EUT has also been tested and complied with the requirements of FCC Part 15, Subpart B, recorded in a separate test report.



2 Test Configuration of Equipment Under Test

The EUT has been associated with peripherals and configuration operated in a manner tended to maximize its emission characteristics in a typical application. Frequency range investigated: conducted emission (150 kHz to 30 MHz) and radiated emission (9 kHz to the 10th harmonic of the highest fundamental frequency or to 40 GHz, whichever is lower). For radiated measurement, pre-scanned in three orthogonal panels, X, Y, Z. The worst cases (Y plane) were recorded in this report.

The final configuration from all the combinations and the worst-case data rates were investigated by measuring the maximum power across all the data rates and modulation modes under section 2.2.

Based on the worst configuration found above, the RF power setting is set individually to meet FCC compliance limit for the final conducted and radiated tests shown in section 2.3.

2.1 Carrier Frequency and Channel

Frequency Band	Channel	Freq. (MHz)	Channel	Freq. (MHz)
2400-2483.5 MHz	1	2412	7	2442
	2	2417	8	2447
	3	2422	9	2452
	4	2427	10	2457
	5	2432	11	2462
	6	2437		



2.2 Pre-Scanned RF Power

Preliminary tests were performed in different data rate and data rate associated with the highest power were chosen for full test shown in the following tables.

<SISO Ant. 1>

Channel	Frequency	2.4GHz 802.11b Average Power (dBm)			
		DSSS Data Rate			
		1 Mbps	2 Mbps	5.5 Mbps	11 Mbps
CH 01	2412MHz	17.30	17.26	17.28	17.29
CH 06	2437MHz	18.48	18.43	18.26	18.43
CH 11	2462MHz	18.91	18.77	18.86	18.90

Channel	Frequency	2.4GHz 802.11b RF Power (dBm)			
		DSSS Data Rate			
		1 Mbps	2 Mbps	5.5 Mbps	11 Mbps
CH 01	2412MHz	19.59	19.55	19.52	19.57
CH 06	2437MHz	20.67	20.66	20.65	20.60
CH 11	2462MHz	21.09	21.03	21.01	21.05

Channel	Frequency	2.4GHz 802.11g Average Power (dBm)							
		OFDM Data Rate							
		6Mbps	9Mbps	12Mbps	18Mbps	24Mbps	36Mbps	48Mbps	54Mbps
CH 01	2412MHz	16.54	16.48	16.50	16.53	16.18	15.78	14.66	14.83
CH 06	2437MHz	17.30	17.08	17.14	17.27	16.72	15.92	14.85	14.76
CH 11	2462MHz	16.18	15.96	16.13	16.04	15.44	15.59	15.57	15.20

Channel	Frequency	2.4GHz 802.11g RF Power (dBm)							
		OFDM Data Rate							
		6Mbps	9Mbps	12Mbps	18Mbps	24Mbps	36Mbps	48Mbps	54Mbps
CH 01	2412MHz	22.00	21.95	21.93	22.69	23.66	23.31	23.11	23.10
CH 06	2437MHz	22.37	22.31	22.32	22.97	23.58	23.54	23.32	23.33
CH 11	2462MHz	21.95	20.91	21.93	22.55	24.14	23.96	23.79	23.94



Channel	Frequency	2.4GHz 802.11n HT20 Average Power (dBm)							
		OFDM Data Rate							
		MCS0	MCS1	MCS2	MCS3	MCS4	MCS5	MCS6	MCS7
CH 01	2412MHz	16.35	16.23	16.34	15.67	15.72	15.79	14.63	14.69
CH 06	2437MHz	16.81	16.69	16.77	15.98	15.68	15.82	14.82	15.07
CH 11	2462MHz	15.51	15.37	15.48	15.21	15.36	15.22	15.19	14.12

Channel	Frequency	2.4GHz 802.11n HT20 RF Power (dBm)							
		OFDM Data Rate							
		MCS0	MCS1	MCS2	MCS3	MCS4	MCS5	MCS6	MCS7
CH 01	2412MHz	21.96	21.92	21.91	23.10	23.14	23.16	23.26	22.92
CH 06	2437MHz	22.33	22.31	22.29	23.38	23.29	23.34	23.32	23.28
CH 11	2462MHz	21.75	21.72	21.63	23.62	23.73	23.54	24.11	23.47

Channel	Frequency	2.4GHz 802.11ac VHT20 Average Power (dBm)								
		OFDM Data Rate								
		MCS0	MCS1	MCS2	MCS3	MCS4	MCS5	MCS6	MCS7	MCS8
CH 01	2412MHz	16.44	16.34	16.38	15.89	15.72	15.65	15.29	14.79	14.21
CH 06	2437MHz	16.75	16.68	16.72	15.73	16.04	15.55	14.87	15.06	12.48
CH 11	2462MHz	14.97	14.88	14.91	14.68	14.50	14.61	14.84	14.36	13.25

Channel	Frequency	2.4GHz 802.11ac VHT20 RF Power (dBm)								
		OFDM Data Rate								
		MCS0	MCS1	MCS2	MCS3	MCS4	MCS5	MCS6	MCS7	MCS8
CH 01	2412MHz	21.97	21.91	21.93	23.38	23.32	23.07	23.25	22.94	23.07
CH 06	2437MHz	22.12	22.08	22.01	23.38	23.54	23.30	23.43	23.33	22.93
CH 11	2462MHz	21.41	21.36	21.21	23.52	23.33	23.28	23.99	23.51	23.40



<SISO Ant. 2>

Channel	Frequency	2.4GHz 802.11b Average Power (dBm)			
		DSSS Data Rate			
		1 Mbps	2 Mbps	5.5 Mbps	11 Mbps
CH 01	2412MHz	14.35	14.30	14.32	14.33
CH 06	2437MHz	14.88	14.85	14.87	14.87
CH 11	2462MHz	14.96	14.84	14.91	14.94

Channel	Frequency	2.4GHz 802.11b RF Power (dBm)			
		DSSS Data Rate			
		1 Mbps	2 Mbps	5.5 Mbps	11 Mbps
CH 01	2412MHz	16.66	16.61	16.62	16.64
CH 06	2437MHz	16.97	16.92	16.88	16.89
CH 11	2462MHz	17.00	16.92	16.89	16.95

Channel	Frequency	2.4GHz 802.11g Average Power (dBm)							
		OFDM Data Rate							
		6Mbps	9Mbps	12Mbps	18Mbps	24Mbps	36Mbps	48Mbps	54Mbps
CH 01	2412MHz	13.41	13.24	13.27	13.40	13.20	12.84	11.94	11.82
CH 06	2437MHz	13.73	13.64	13.71	13.70	13.52	12.98	12.06	11.83
CH 11	2462MHz	12.47	12.45	12.34	12.44	12.16	11.69	11.79	11.89

Channel	Frequency	2.4GHz 802.11g RF Power (dBm)							
		OFDM Data Rate							
		6Mbps	9Mbps	12Mbps	18Mbps	24Mbps	36Mbps	48Mbps	54Mbps
CH 01	2412MHz	18.66	18.60	18.62	18.64	20.09	19.85	19.64	19.92
CH 06	2437MHz	18.47	18.41	18.44	18.46	19.07	19.45	18.84	18.83
CH 11	2462MHz	17.75	17.72	17.70	17.74	19.37	18.72	19.70	19.25



Channel	Frequency	2.4GHz 802.11n HT20 Average Power (dBm)							
		OFDM Data Rate							
		MCS0	MCS1	MCS2	MCS3	MCS4	MCS5	MCS6	MCS7
CH 01	2412MHz	13.19	13.13	13.15	12.86	12.86	12.74	11.93	11.85
CH 06	2437MHz	13.58	13.52	13.55	12.82	12.81	12.91	12.13	11.96
CH 11	2462MHz	11.82	11.72	11.79	11.78	11.64	11.77	11.80	11.01

Channel	Frequency	2.4GHz 802.11n HT20 RF Power (dBm)							
		OFDM Data Rate							
		MCS0	MCS1	MCS2	MCS3	MCS4	MCS5	MCS6	MCS7
CH 01	2412MHz	18.78	18.72	18.74	19.79	19.92	20.18	20.00	19.69
CH 06	2437MHz	18.67	18.62	18.63	18.90	19.21	19.36	18.90	19.08
CH 11	2462MHz	17.75	17.72	17.69	18.26	19.57	19.41	19.37	18.52

Channel	Frequency	2.4GHz 802.11ac VHT20 Average Power (dBm)								
		OFDM Data Rate								
		MCS0	MCS1	MCS2	MCS3	MCS4	MCS5	MCS6	MCS7	MCS8
CH 01	2412MHz	13.17	13.09	13.14	12.65	12.79	12.94	11.87	11.94	11.02
CH 06	2437MHz	13.59	13.55	13.56	12.70	12.70	12.85	12.07	12.02	10.13
CH 11	2462MHz	11.28	11.12	11.24	11.25	11.18	11.16	11.17	11.08	9.99

Channel	Frequency	2.4GHz 802.11ac VHT20 RF Power (dBm)								
		OFDM Data Rate								
		MCS0	MCS1	MCS2	MCS3	MCS4	MCS5	MCS6	MCS7	MCS8
CH 01	2412MHz	18.76	18.72	18.71	19.68	19.48	19.72	20.21	19.80	20.28
CH 06	2437MHz	18.86	18.72	18.65	18.71	19.23	19.05	19.30	18.92	18.84
CH 11	2462MHz	17.23	17.21	17.13	19.15	19.11	18.84	19.11	19.02	18.55



<MIMO Ant. 1+2>

Channel	Frequency	2.4GHz 802.11b Average Power (dBm)			
		DSSS Data Rate			
		1 Mbps	2 Mbps	5.5 Mbps	11 Mbps
CH 01	2412MHz	18.43	18.39	18.41	18.40
CH 06	2437MHz	19.41	19.36	19.38	19.36
CH 11	2462MHz	19.80	19.59	19.79	19.76

Channel	Frequency	2.4GHz 802.11b RF Power (dBm)			
		DSSS Data Rate			
		1 Mbps	2 Mbps	5.5 Mbps	11 Mbps
CH 01	2412MHz	20.67	20.58	20.60	20.62
CH 06	2437MHz	21.55	21.51	21.51	21.52
CH 11	2462MHz	21.84	21.71	21.72	21.74

Channel	Frequency	2.4GHz 802.11g Average Power (dBm)							
		OFDM Data Rate							
		6Mbps	9Mbps	12Mbps	18Mbps	24Mbps	36Mbps	48Mbps	54Mbps
CH 01	2412MHz	17.48	17.41	17.39	17.46	17.20	16.88	15.88	16.11
CH 06	2437MHz	18.18	17.94	17.86	18.15	17.59	16.92	15.91	15.94
CH 11	2462MHz	16.92	16.83	16.86	16.89	16.66	16.18	16.26	16.31

Channel	Frequency	2.4GHz 802.11g RF Power (dBm)							
		OFDM Data Rate							
		6Mbps	9Mbps	12Mbps	18Mbps	24Mbps	36Mbps	48Mbps	54Mbps
CH 01	2412MHz	22.84	22.80	22.81	23.41	24.48	24.58	24.18	24.30
CH 06	2437MHz	23.07	23.03	23.04	23.59	24.45	24.37	24.02	24.15
CH 11	2462MHz	22.48	22.46	22.41	23.09	24.50	24.37	24.24	24.62



Channel	Frequency	2.4GHz 802.11n HT20 Average Power (dBm)							
		OFDM Data Rate							
		MCS8	MCS9	MCS10	MCS11	MCS12	MCS13	MCS14	MCS15
CH 01	2412MHz	17.37	17.26	17.34	16.78	16.95	16.93	15.95	16.21
CH 06	2437MHz	17.77	17.70	17.74	17.04	16.75	16.78	16.13	15.98
CH 11	2462MHz	16.35	16.25	16.31	16.12	16.22	16.16	16.32	15.33

Channel	Frequency	2.4GHz 802.11n HT20 RF Power (dBm)							
		OFDM Data Rate							
		MCS8	MCS9	MCS10	MCS11	MCS12	MCS13	MCS14	MCS15
CH 01	2412MHz	23.04	22.98	22.93	24.33	24.29	24.21	24.27	24.22
CH 06	2437MHz	23.13	23.08	23.07	24.36	24.26	24.28	24.20	24.10
CH 11	2462MHz	22.42	22.31	22.29	23.74	24.18	24.09	24.75	24.07

Channel	Frequency	2.4GHz 802.11ac VHT20 Average Power (dBm)								
		OFDM Data Rate								
		MCS0	MCS1	MCS2	MCS3	MCS4	MCS5	MCS6	MCS7	MCS8
CH 01	2412MHz	17.41	17.24	17.39	16.90	17.15	17.20	16.22	15.85	14.97
CH 06	2437MHz	17.77	17.71	17.75	17.07	16.90	16.91	15.89	15.91	13.97
CH 11	2462MHz	15.87	15.72	15.79	15.58	15.48	15.60	15.65	15.17	14.40

Channel	Frequency	2.4GHz 802.11ac VHT20 RF Power (dBm)								
		OFDM Data Rate								
		MCS0	MCS1	MCS2	MCS3	MCS4	MCS5	MCS6	MCS7	MCS8
CH 01	2412MHz	23.02	23.00	22.91	24.43	24.53	24.78	24.65	24.13	23.92
CH 06	2437MHz	23.09	23.05	23.03	23.97	24.26	24.32	24.33	24.18	23.81
CH 11	2462MHz	22.03	21.96	21.83	23.75	23.64	23.75	24.47	24.17	23.95

Note: MIMO Ant. 1+2 is a calculated result from sum of the power MIMO Ant. 1 and MIMO Ant. 2.



2.3 Test Mode

Final test mode of conducted test items and radiated spurious emissions are considering the modulation and worse data rates from the power table described in section 2.2.

Single Antenna

Modulation	Data Rate
802.11b	1 Mbps
802.11g	6 Mbps
802.11n HT20	MCS0
802.11ac VHT20	MCS0

MIMO Antenna

Modulation	Data Rate
802.11b	1 Mbps
802.11g	6 Mbps
802.11n HT20	MCS0
802.11ac VHT20	MCS0

Test Cases	
AC Conducted Emission	Mode 1 :GSM850 Idle + WLAN (2.4GHz) Link + Bluetooth Link + Adapter + MP3

2.4 Connection Diagram of Test System

<WLAN Tx Mode>

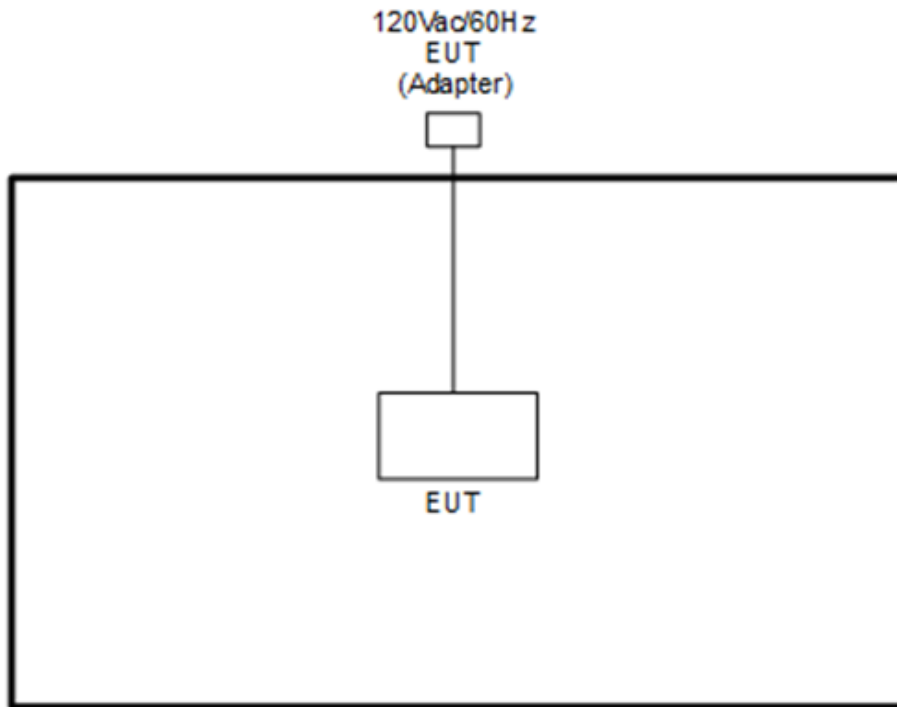

<AC Conducted Emission Mode>

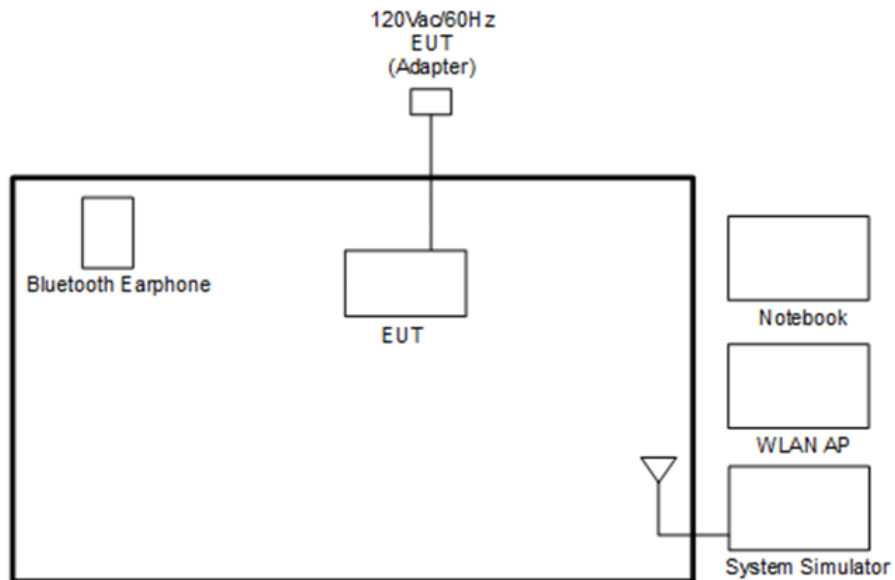



2.5 Support Unit used in test configuration and system

Item	Equipment	Trade Name	Model Name	FCC ID	Data Cable	Power Cord
1.	System Simulator	Anritsu	MT8820C	N/A	N/A	Unshielded, 1.8 m
2.	WLAN AP	D-Link	DIR-628	KA2DIR628A2	N/A	Unshielded, 1.8 m
3.	Notebook	DELL	Latitude E6320	FCC DoC/ Contains FCC ID: QDS-BRCM1054	N/A	AC I/P: Unshielded, 1.2 m DC O/P: Shielded, 1.8 m
4.	Bluetooth Earphone	Sony Ericsson	MW600	PY7DDA-2029	N/A	N/A
5.	SD Card	SanDisk	MicroSD HC	FCC DoC	N/A	N/A

2.6 EUT Operation Test Setup

For WLAN function, programmed RF utility, "QRCT" installed in the notebook make the EUT provide functions like channel selection and power level for continuous transmitting and receiving signals.

2.7 Measurement Results Explanation Example

For all conducted test items:

The offset level is set in the spectrum analyzer to compensate the RF cable loss and attenuator factor between EUT conducted output port and spectrum analyzer. With the offset compensation, the spectrum analyzer reading level is exactly the EUT RF output level.

Example:

The spectrum analyzer offset is derived from RF cable loss and attenuator factor.

Offset = RF cable loss + attenuator factor.

Following shows an offset computation example with cable loss 4.2 dB and 10dB attenuator.

$$\begin{aligned} \text{Offset(dB)} &= \text{RF cable loss(dB)} + \text{attenuator factor(dB)}. \\ &= 4.2 + 10 = 14.2 \text{ (dB)} \end{aligned}$$

3 Test Result

3.1 6dB and 99% Bandwidth Measurement

3.1.1 Limit of 6dB and 99% Bandwidth

The minimum 6 dB bandwidth shall be at least 500 kHz.

3.1.2 Measuring Instruments

The measuring equipment is listed in the section 4 of this test report.

3.1.3 Test Procedures

1. The testing follows FCC KDB Publication No. 558074 DTS D01 Meas. Guidance v03r05.
2. The RF output of EUT was connected to the spectrum analyzer by RF cable and attenuator. The path loss was compensated to the results for each measurement.
3. Set to the maximum power setting and enable the EUT transmit continuously.
4. Make the measurement with the spectrum analyzer's resolution bandwidth (RBW) = 100 kHz. Set the Video bandwidth (VBW) = 300 kHz. In order to make an accurate measurement. The 6 dB bandwidth must be greater than 500 kHz.
5. For 99% Bandwidth Measurement, the spectrum analyzer's resolution bandwidth (RBW) = 1MHz and set the Video bandwidth (VBW) = 3MHz.
6. Measure and record the results in the test report.

3.1.4 Test Setup

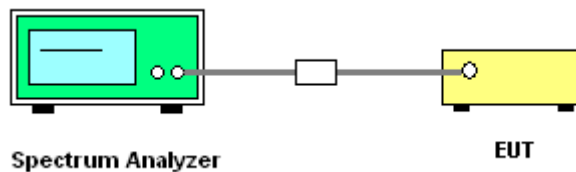



3.1.5 Test Result of 6dB and 99% Occupied Bandwidth

Please refer to Appendix A of this report.

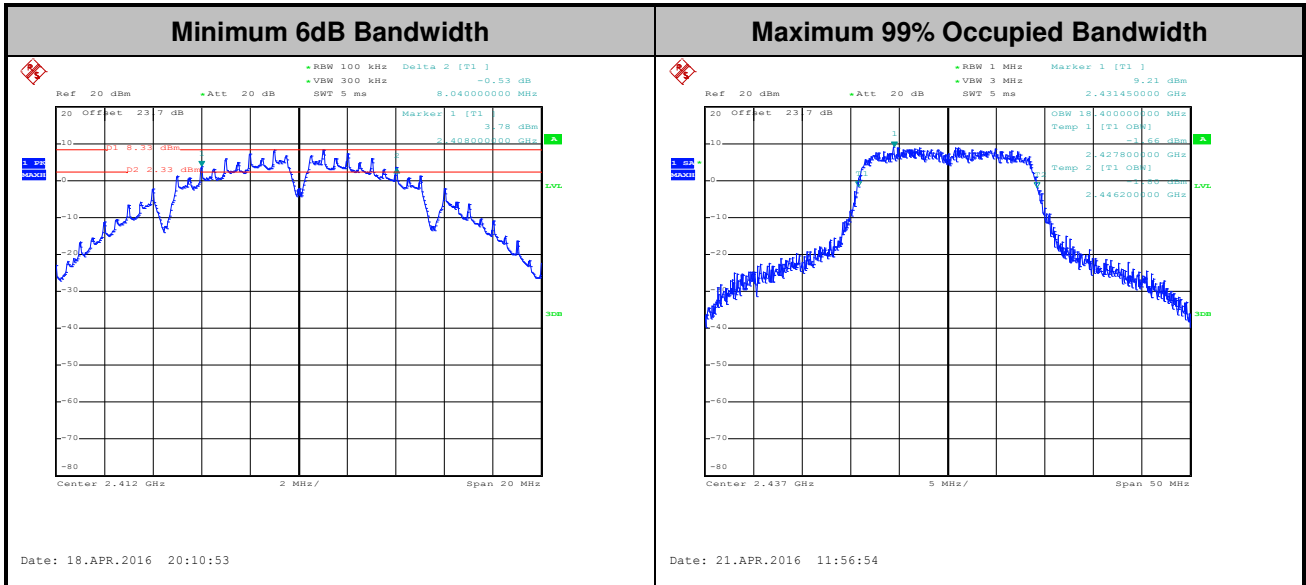

Note : The occupied channel bandwidth is maintained within the band of operation for all of the modulations.

3.2 Maximum Average Output Power Measurement

3.2.1 Limit of Average Output Power

For systems using digital modulation in the 2400-2483.5MHz, the limit for average output power is 30dBm. If transmitting antenna with directional gain greater than 6dBi is used, the average output power from the intentional radiator shall be reduced below the above stated value by the amount in dB that the directional gain of the antenna exceeds 6 dBi. In case of point-to-point operation, the limit has to be reduced by 1dB for every 3dB that the directional gain of the antenna exceeds 6dBi.

3.2.2 Measuring Instruments

The measuring equipment is listed in the section 4 of this test report.

3.2.3 Test Procedures

1. The testing follows Measurement Procedure 10.2 Method PKPSD of FCC KDB Publication No. 558074 D01 DTS Meas. Guidance v03r05

1. The RF output of EUT was connected to the power meter by RF cable and attenuator. The path loss was compensated to the results for each measurement.
2. Set to the maximum power setting and enable the EUT transmit continuously.
3. Measure the conducted output power and record the results in the test report.
4. For MIMO mode, calculation method follows FCC KDB 662911 D01 Multiple Transmitter Output v02r01.

3.2.4 Test Setup

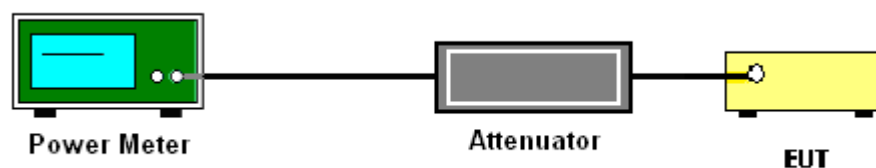

3.2.5 Test Result of Peak Output Power (Reporting Only)

Please refer to Appendix A of this report.

3.2.6 Test Result of Average output Power

Please refer to Appendix A of this report.



3.3 Power Spectral Density Measurement

3.3.1 Limit of Power Spectral Density

The power spectral density shall not be greater than 8dBm in any 3kHz band at any time interval of continuous transmission.

3.3.2 Measuring Instruments

The measuring equipment is listed in the section 4 of this test report.

3.3.3 Test Procedures

2. The testing follows Measurement Procedure 10.2 Method PKPSD of FCC KDB Publication No. 558074 D01 DTS Meas. Guidance v03r05
3. The RF output of EUT was connected to the spectrum analyzer by RF cable and attenuator. The path loss was compensated to the results for each measurement.
4. Set to the maximum power setting and enable the EUT transmit continuously.
5. Make the measurement with the spectrum analyzer's resolution bandwidth (RBW) = 3 kHz. Video bandwidth VBW = 10 kHz In order to make an accurate measurement, set the span to 1.5 times DTS Channel Bandwidth. (6dB BW)
6. **Detector = RMS, Sweep time = auto couple. Allow max hold to run for at least 60 s, or longer as needed to allow the trace to stabilize. Use the peak marker function to determine the maximum power level.**
7. Measure and record the results in the test report.
8. For MIMO mode, calculation method follows FCC KDB 662911 D01 Multiple Transmitter Output v02r01.

If measurements performed using method (2) plus $10 \log(N)$ exceeds the emission limit, the test should choose method (1) before declaring that the device fails the emission limit.

Method (1): Measure and sum the spectra across the outputs.

The total final Power Spectral Density is from a device with 2 transmitter outputs. The spectrum measurements of the individual outputs are all performed with the same span and number of points, the spectrum value in the first spectral bin of output 1 is summed with that in the first spectral bin of output 2 to obtain the value for the first frequency bin of the summed spectrum.

Method (2): Measure and add $10 \log(N)$ dB, where N is the number of outputs. (N=2)

3.3.4 Test Setup

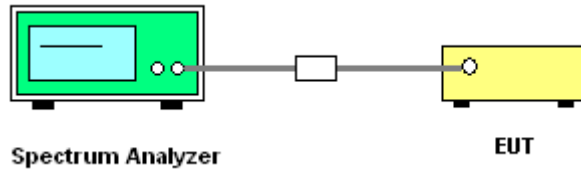



3.3.5 Test Result of Power Spectral Density

Please refer to Appendix A of this report.

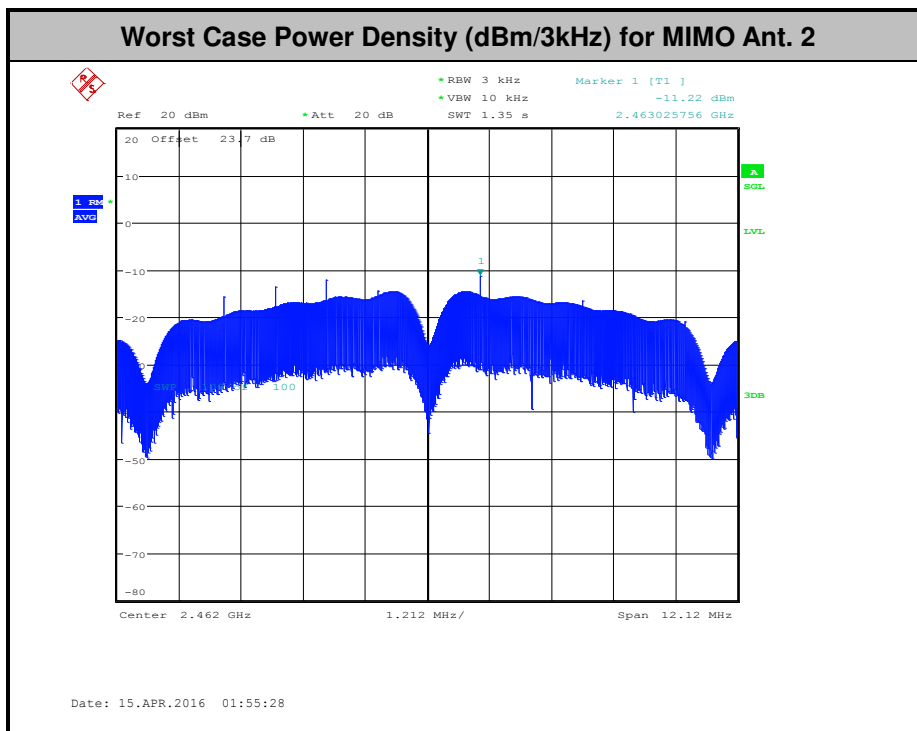
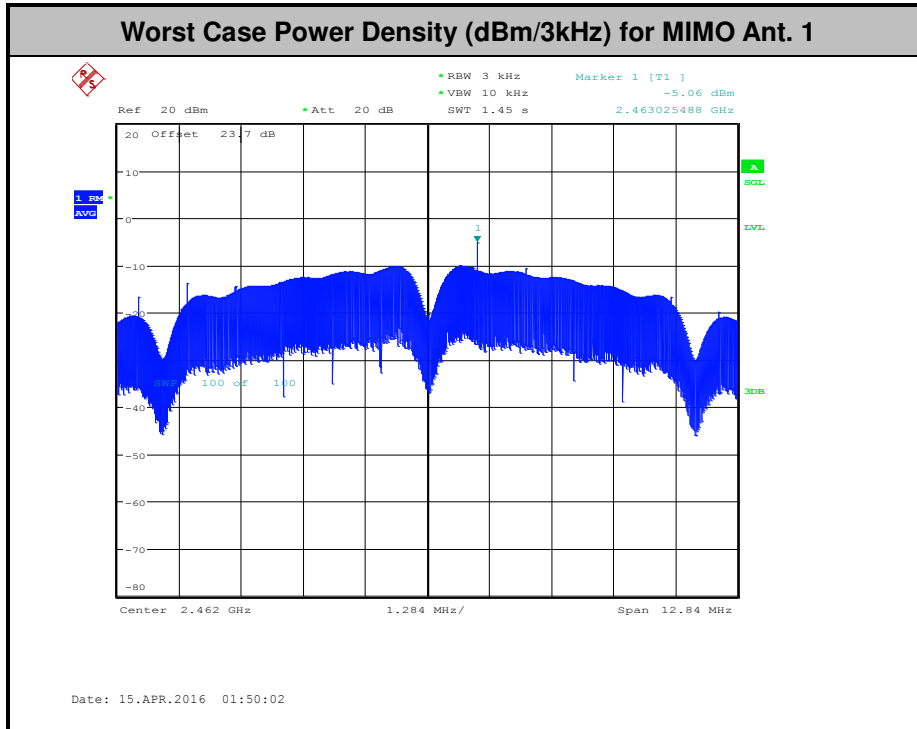

3.4 Conducted Band Edges and Spurious Emission Measurement

3.4.1 Limit of Conducted Band Edges and Spurious Emission Measurement

In any 100 kHz bandwidth outside of the authorized frequency band, the emissions which fall in the non-restricted bands shall be attenuated at least 20 dB / 30dB relative to the maximum PSD level in 100 kHz by RF conducted measurement and radiated emissions which fall in the restricted bands, as defined in Section 15.205(a), must also comply with the radiated emission limits specified in Section 15.209(a).

3.4.2 Measuring Instruments

The measuring equipment is listed in the section 4 of this test report.

3.4.3 Test Procedures

1. The testing follows FCC KDB Publication No. 558074 D01 DTS Meas. Guidance v03r05.
2. The RF output of EUT was connected to the spectrum analyzer by RF cable and attenuator. The path loss was compensated to the results for each measurement.
3. Set to the maximum power setting and enable the EUT transmit continuously.
4. Set RBW = 100 kHz, VBW=300 kHz, Peak Detector. Unwanted Emissions measured in any 100 kHz bandwidth outside of the authorized frequency band shall be attenuated by at least 20 dB relative to the maximum in-band peak PSD level in 100 kHz when maximum peak conducted output power procedure is used. If the transmitter complies with the conducted power limits based on the use of RMS averaging over a time interval, the attenuation required under this paragraph shall be 30 dB instead of 20 dB per 15.247(d).
5. Measure and record the results in the test report.
6. The RF fundamental frequency should be excluded against the limit line in the operating frequency band.

3.4.4 Test Setup

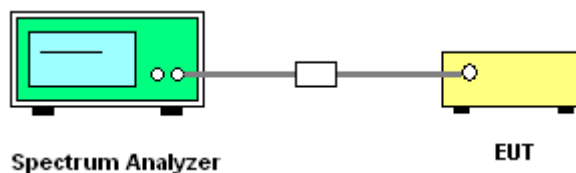



3.4.5 Test Result of Conducted Band Edges and Spurious Emission

Number of TX = 1, Ant. 1 (Measured)

Number of TX	1	Ant. :	1
Test Mode :	802.11b	Temperature :	21~25°C
Test Band :	2.4GHz Low	Relative Humidity :	51~54%
Test Channel :	01	Test Engineer :	Luffy Lin

WLAN 802.11b Channel 01

100kHz PSD reference Level

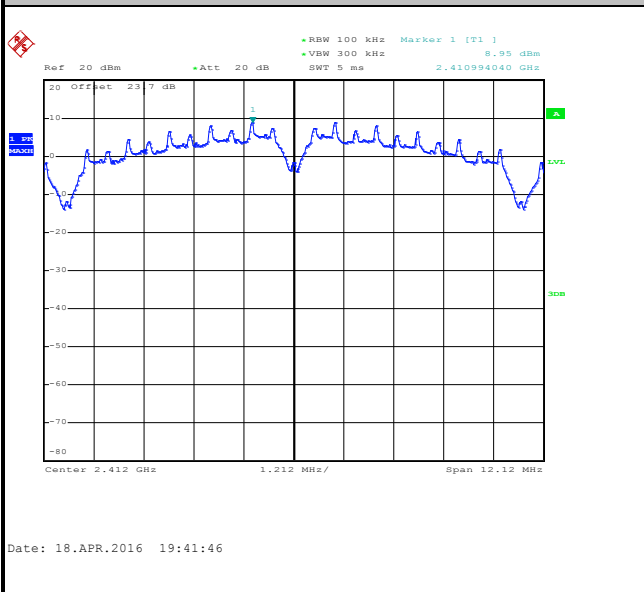

Low Channel Plot

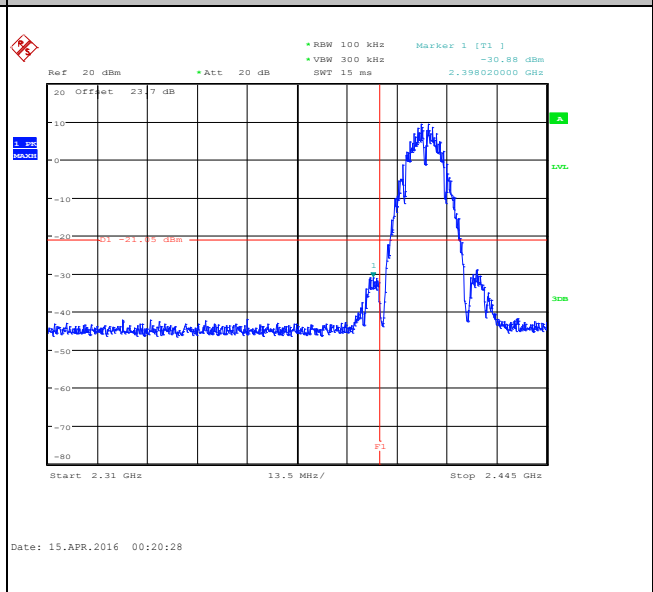

Spurious Emission 30MHz~3GHz

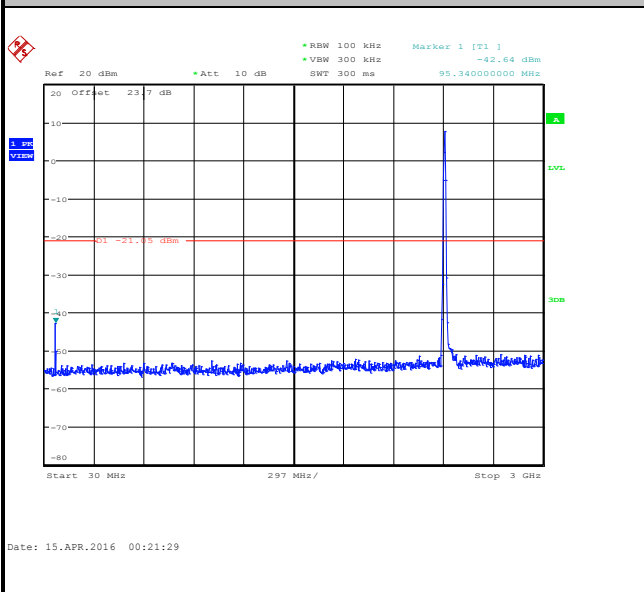

Spurious Emission 2GHz~25GHz

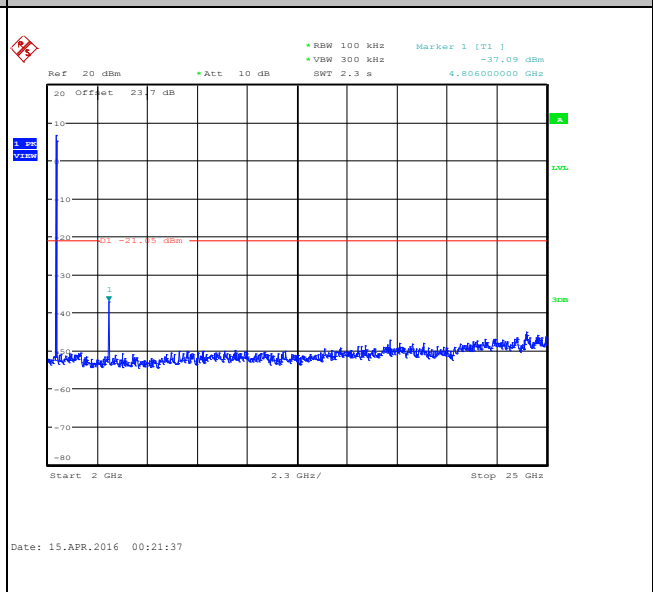



Number of TX :	1	Ant. :	1
Test Mode :	802.11b	Temperature :	21~25°C
Test Band :	2.4GHz Mid	Relative Humidity :	51~54%
Test Channel :	06	Test Engineer :	Luffy Lin

WLAN 802.11b Channel 06

100kHz PSD reference Level

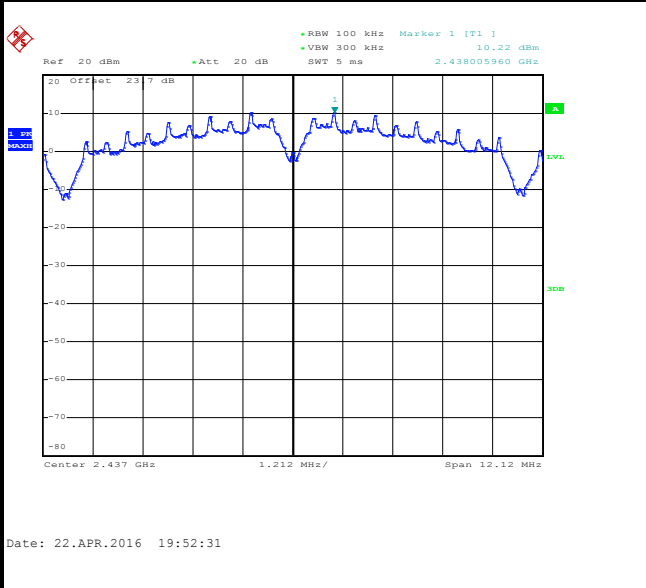

Spurious Emission 30MHz~3GHz

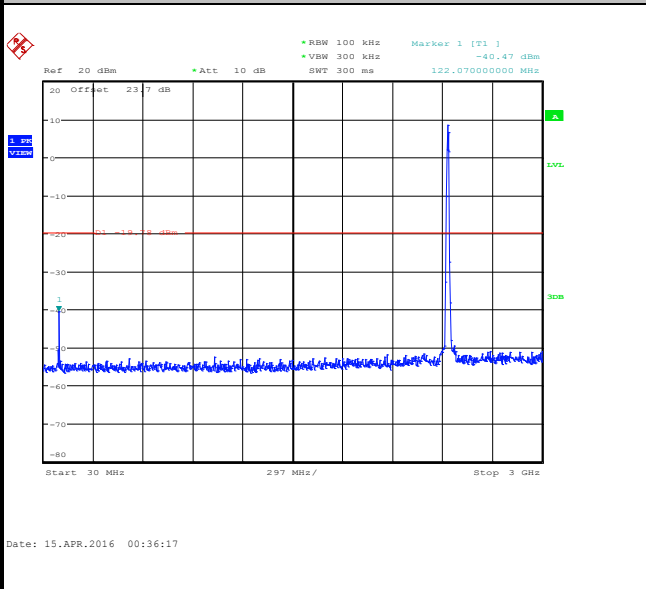

Spurious Emission 2GHz~25GHz

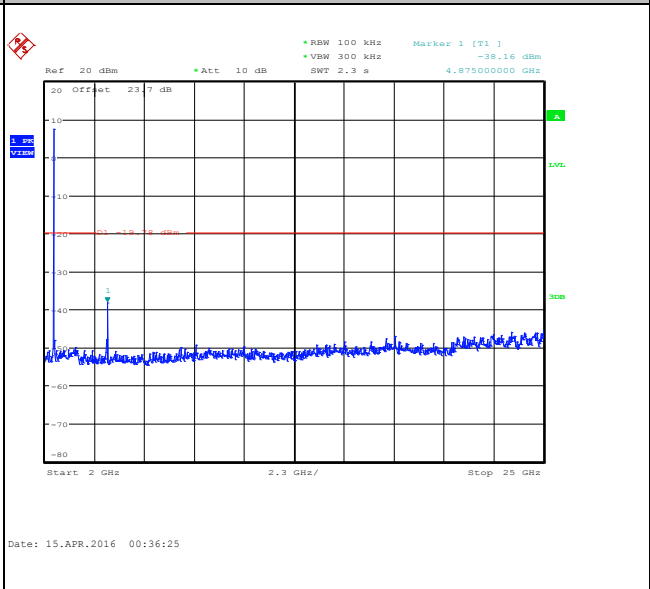



Number of TX :	1	Ant. :	1
Test Mode :	802.11b	Temperature :	21~25°C
Test Band :	2.4GHz High	Relative Humidity :	51~54%
Test Channel :	11	Test Engineer :	Luffy Lin

WLAN 802.11b Channel 11

100kHz PSD reference Level

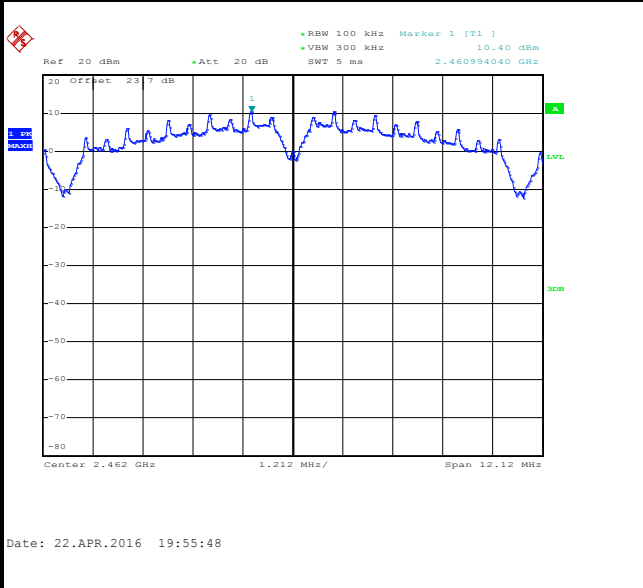

High Channel Plot

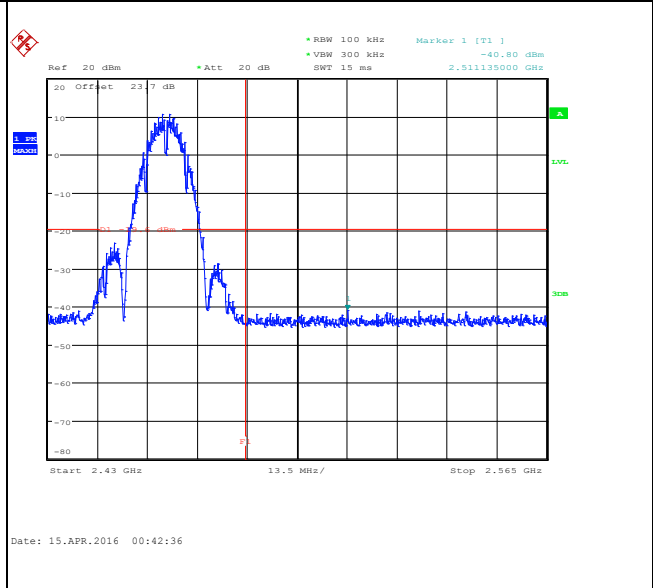

Spurious Emission 30MHz~3GHz

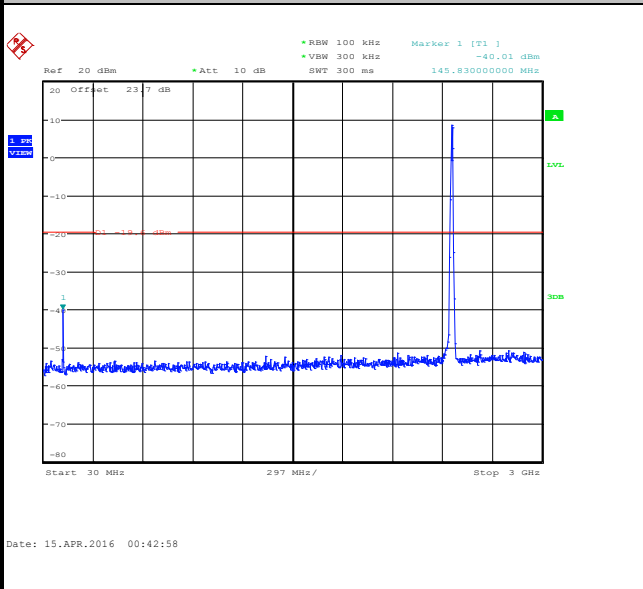

Spurious Emission 2GHz~25GHz

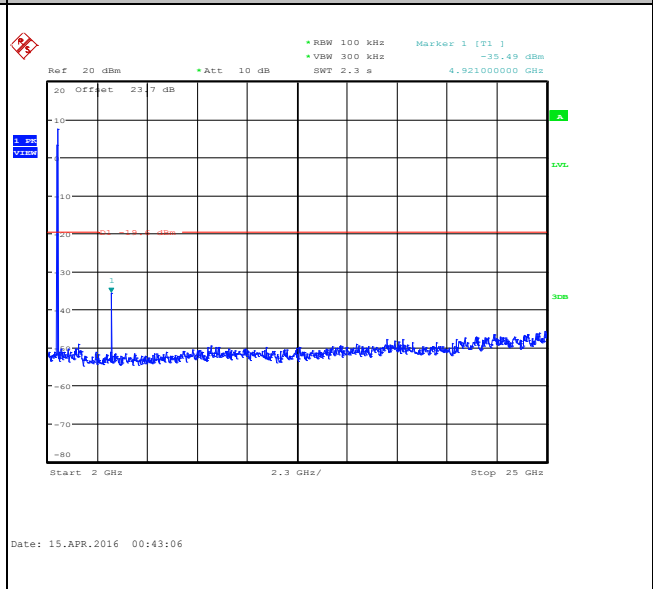



Number of TX :	1	Ant. :	1
Test Mode :	802.11g	Temperature :	21~25°C
Test Band :	2.4GHz Low	Relative Humidity :	51~54%
Test Channel :	01	Test Engineer :	Luffy Lin

WLAN 802.11g Channel 01

100kHz PSD reference Level

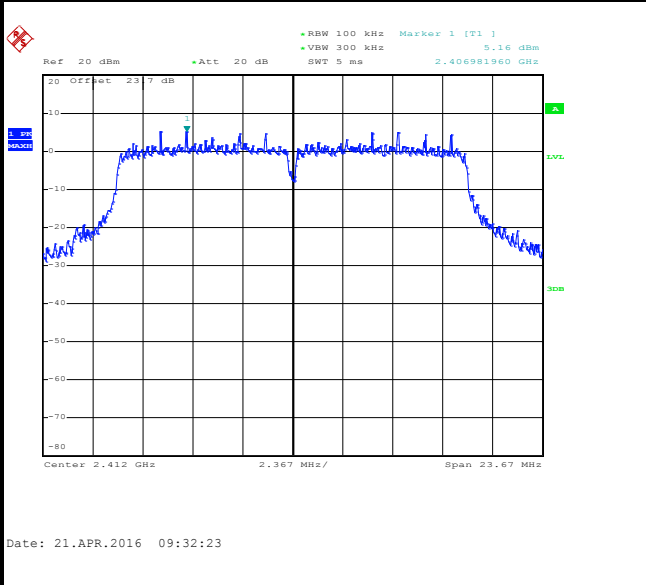

Low Channel Plot

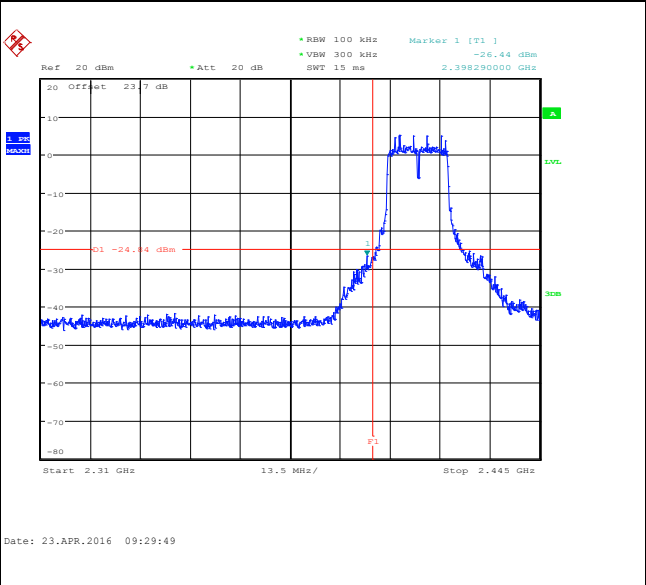

Spurious Emission 30MHz~3GHz

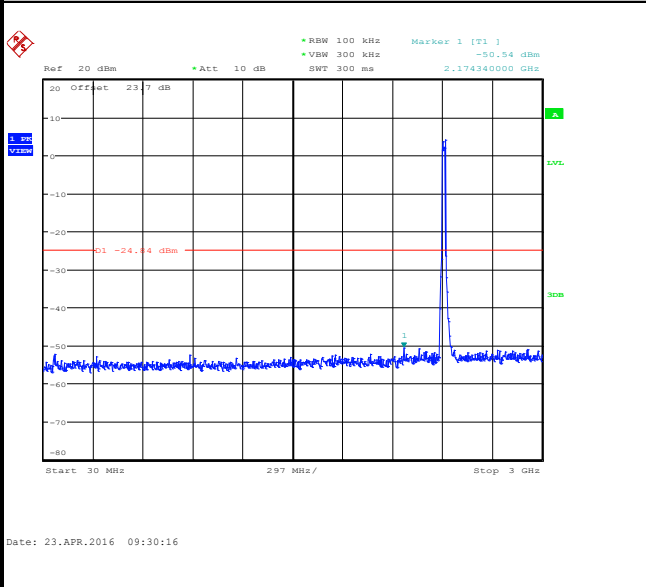

Spurious Emission 2GHz~25GHz

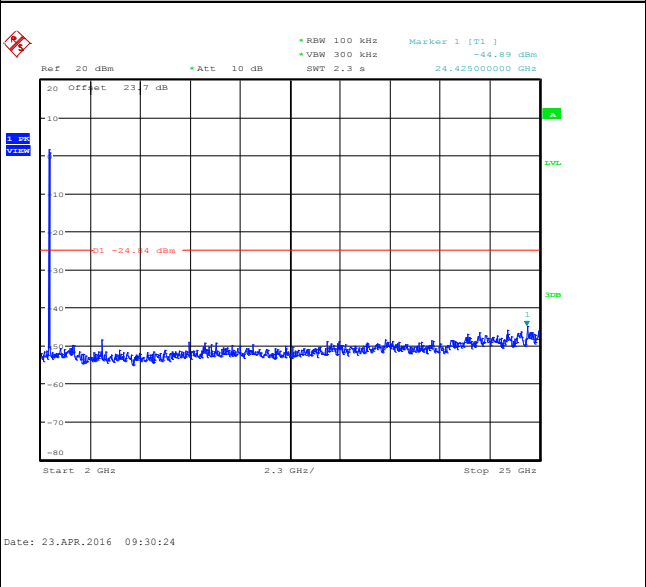



Number of TX :	1	Ant. :	1
Test Mode :	802.11g	Temperature :	21~25°C
Test Band :	2.4GHz Mid	Relative Humidity :	51~54%
Test Channel :	06	Test Engineer :	Luffy Lin

WLAN 802.11g Channel 06

100kHz PSD reference Level

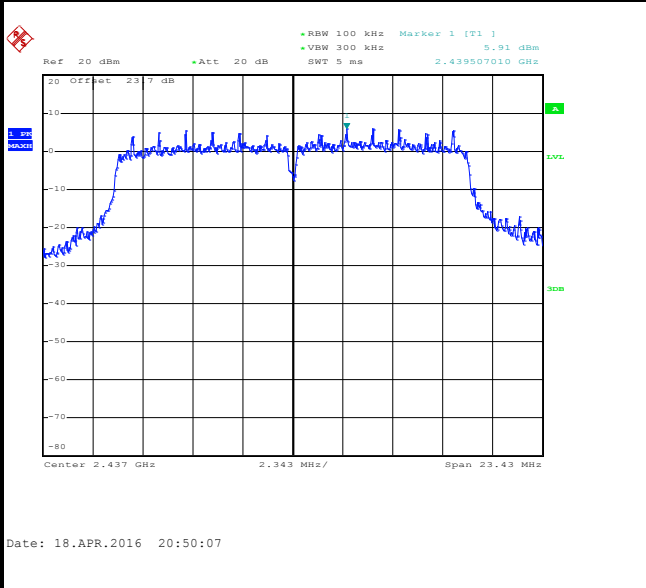

Spurious Emission 30MHz~3GHz

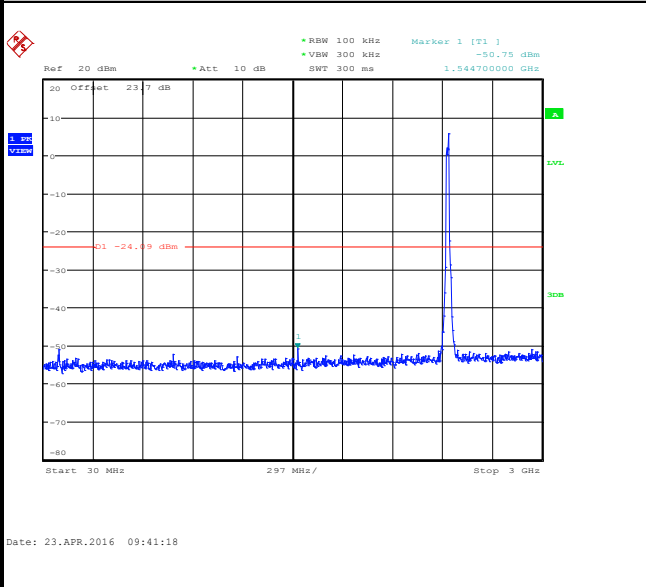

Spurious Emission 2GHz~25GHz

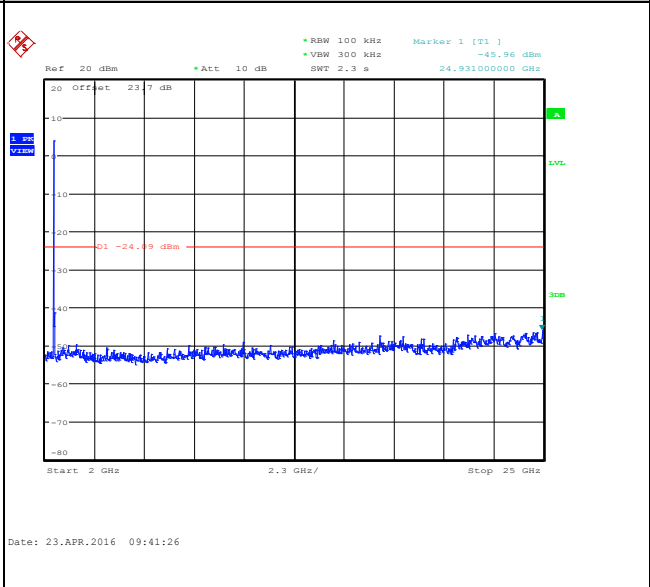



Number of TX :	1	Ant. :	1
Test Mode :	802.11g	Temperature :	21~25°C
Test Band :	2.4GHz High	Relative Humidity :	51~54%
Test Channel :	11	Test Engineer :	Luffy Lin

WLAN 802.11g Channel 11

100kHz PSD reference Level

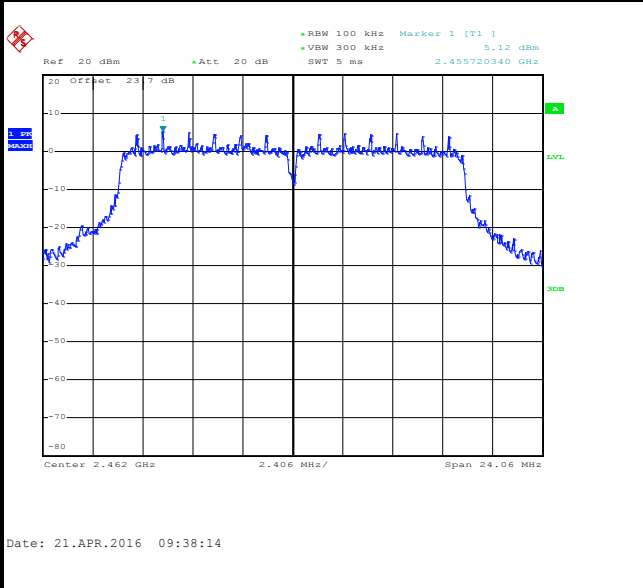

High Channel Plot

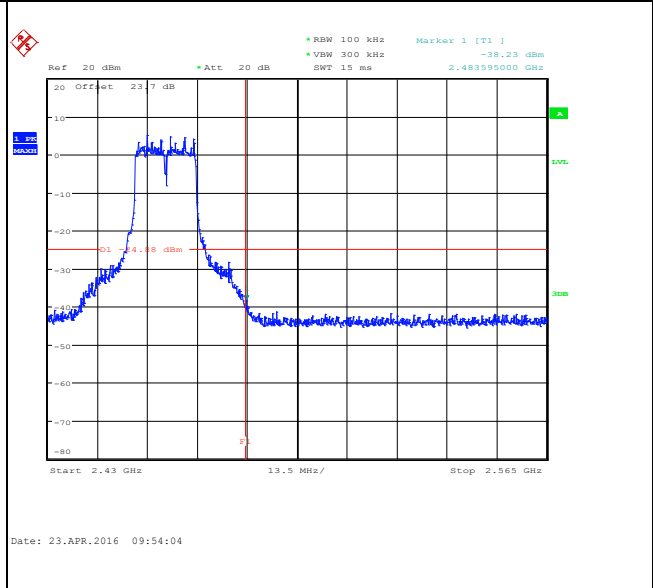

Spurious Emission 30MHz~3GHz

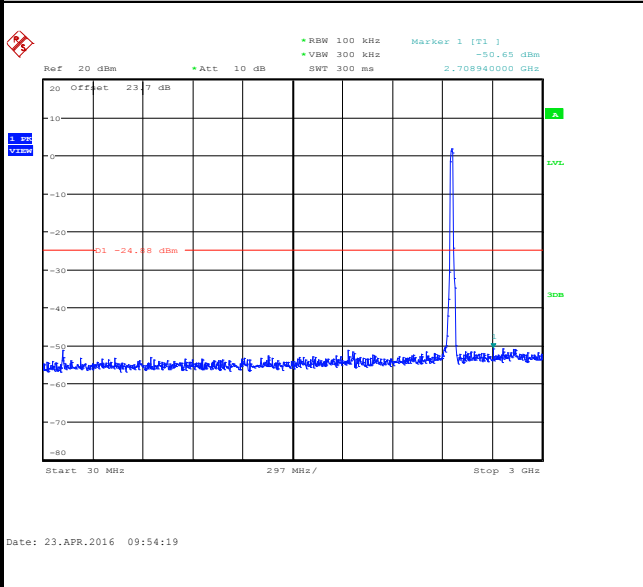

Spurious Emission 2GHz~25GHz

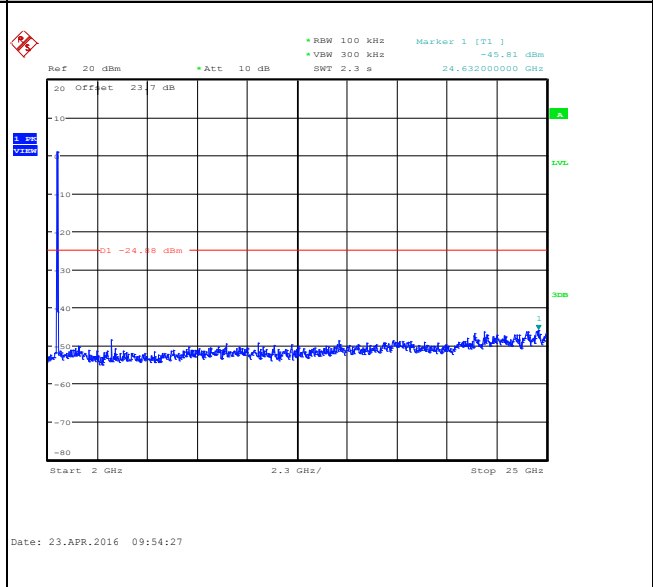



Number of TX :	1	Ant. :	1
Test Mode :	802.11n HT20	Temperature :	21~25°C
Test Band :	2.4GHz Low	Relative Humidity :	51~54%
Test Channel :	01	Test Engineer :	Luffy Lin

WLAN 802.11n HT20 Channel 01

100kHz PSD reference Level

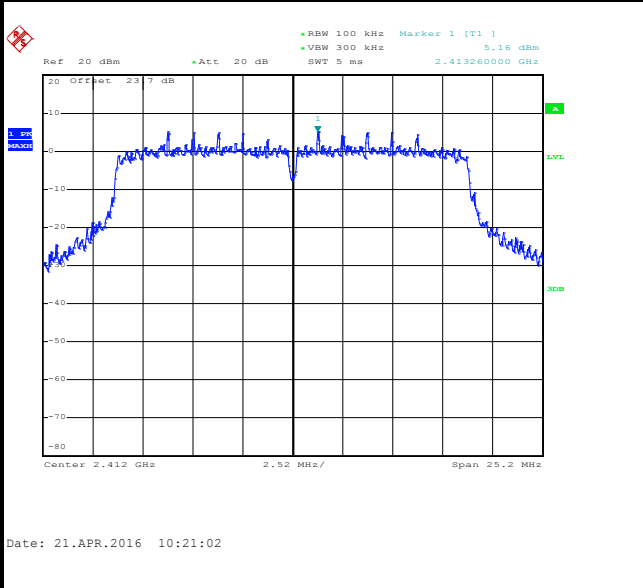

Low Channel Plot

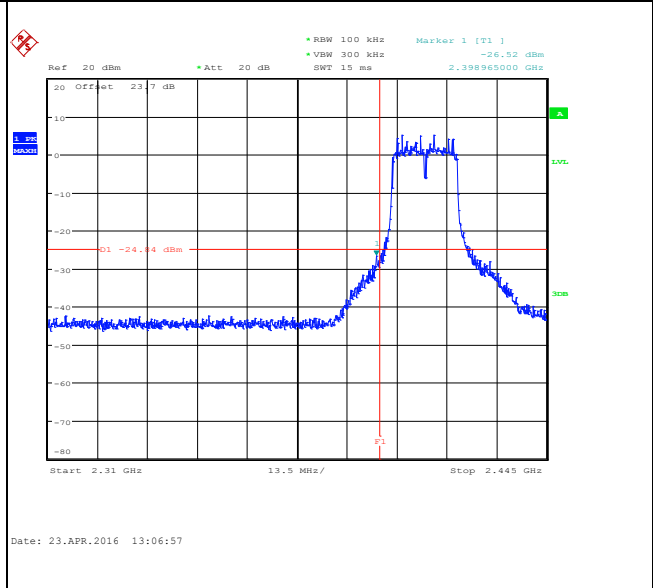

Spurious Emission 30MHz~3GHz

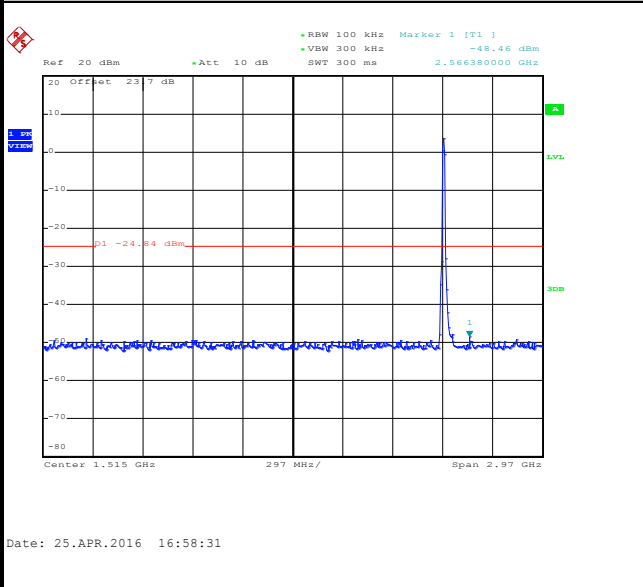

Spurious Emission 2GHz~25GHz

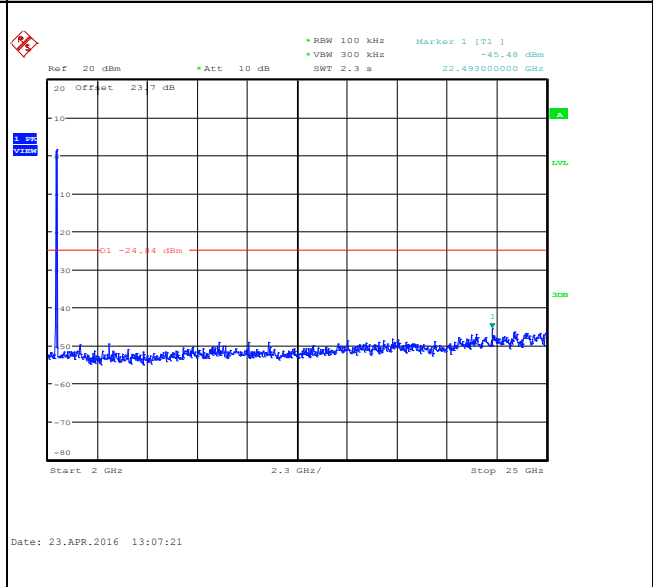



Number of TX :	1	Ant. :	1
Test Mode :	802.11n HT20	Temperature :	21~25°C
Test Band :	2.4GHz Mid	Relative Humidity :	51~54%
Test Channel :	06	Test Engineer :	Luffy Lin

WLAN 802.11n HT20 Channel 06

100kHz PSD reference Level

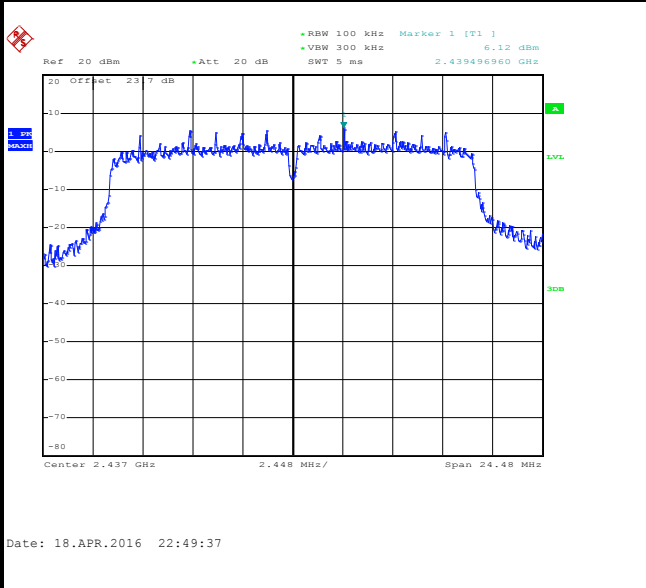

Spurious Emission 30MHz~3GHz

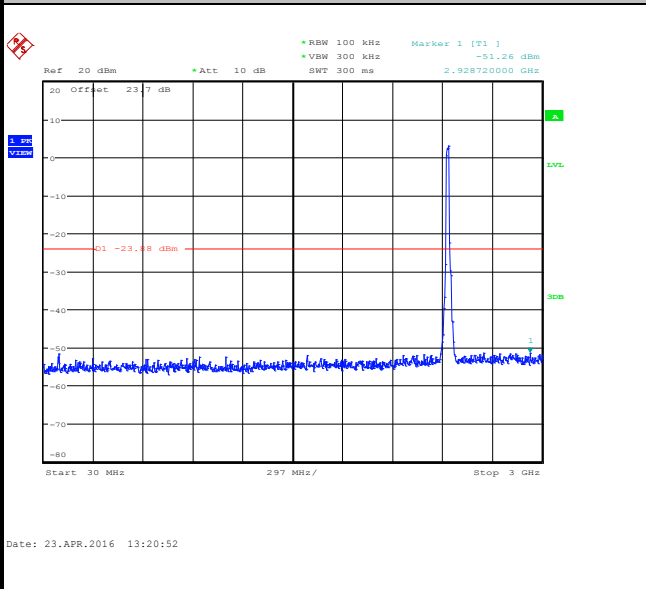

Spurious Emission 2GHz~25GHz

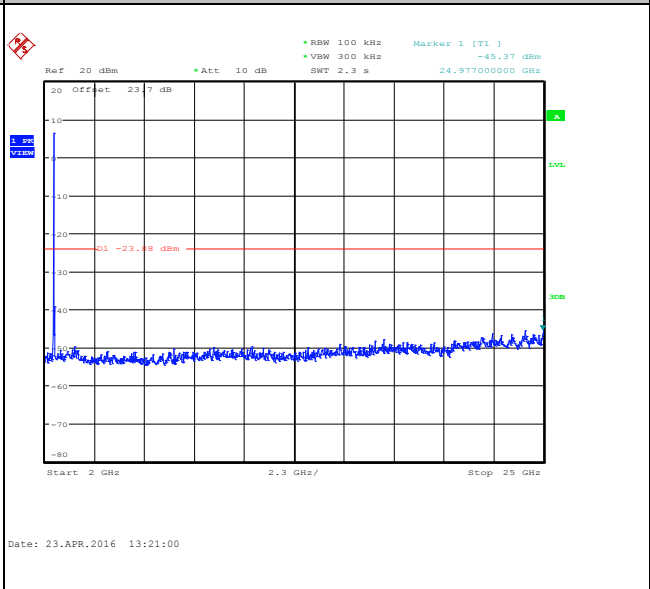



Number of TX :	1	Ant. :	1
Test Mode :	802.11n HT20	Temperature :	21~25°C
Test Band :	2.4GHz High	Relative Humidity :	51~54%
Test Channel :	11	Test Engineer :	Luffy Lin

WLAN 802.11n HT20 Channel 11

100kHz PSD reference Level

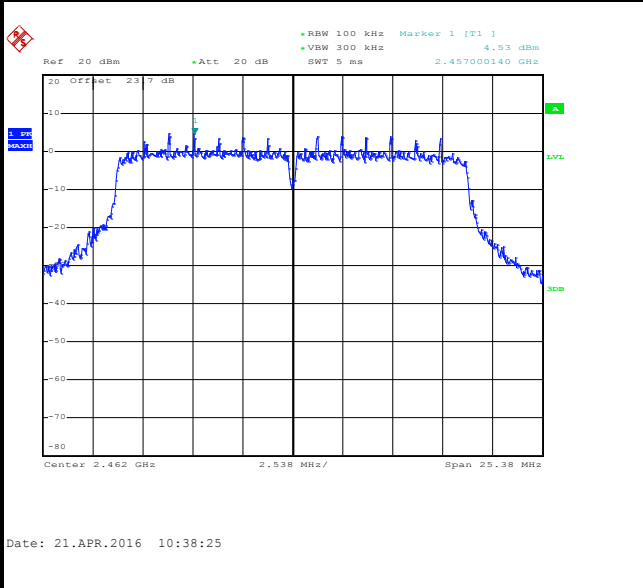

High Channel Plot

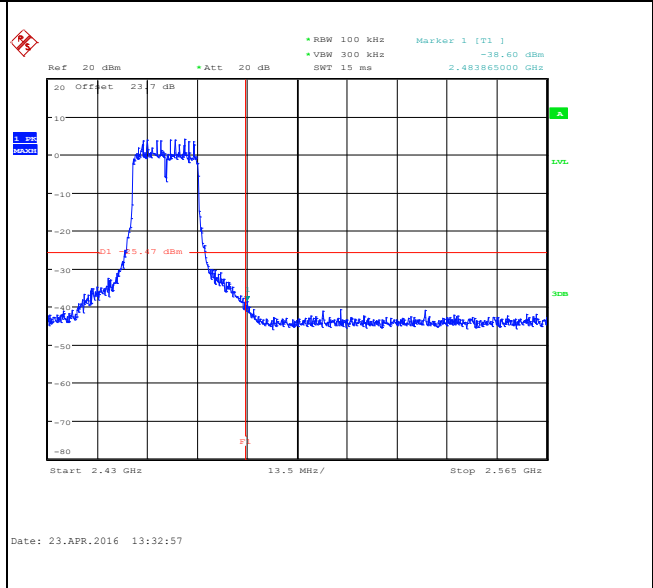

Spurious Emission 30MHz~3GHz

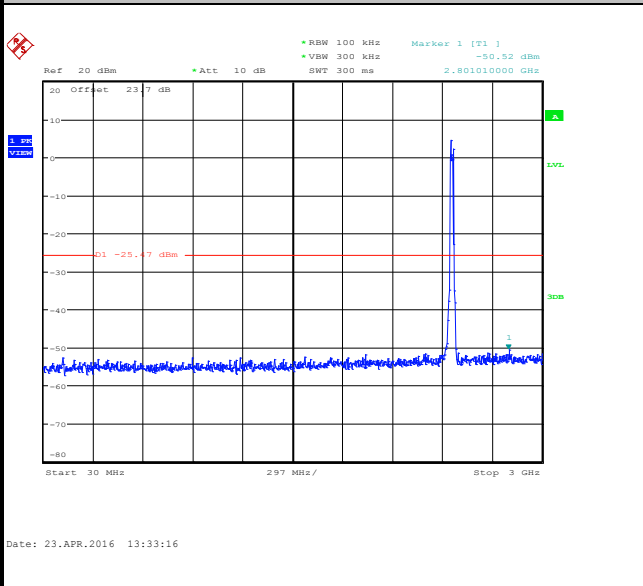

Spurious Emission 2GHz~25GHz

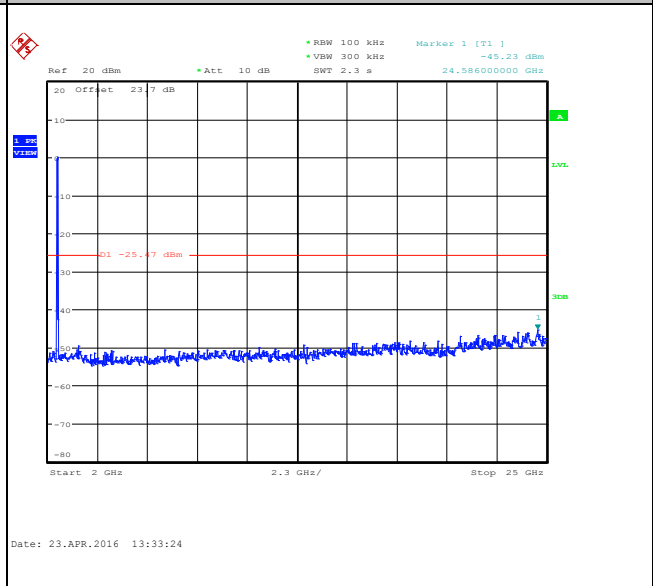



Number of TX :	1	Ant. :	1
Test Mode :	802.11ac VHT20	Temperature :	21~25°C
Test Band :	2.4GHz Low	Relative Humidity :	51~54%
Test Channel :	01	Test Engineer :	Luffy Lin

WLAN 802.11ac VHT20 Channel 01

100kHz PSD reference Level

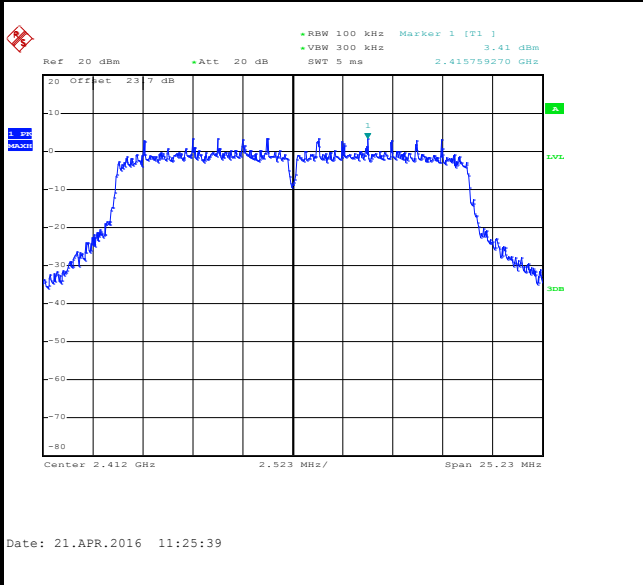

Low Channel Plot

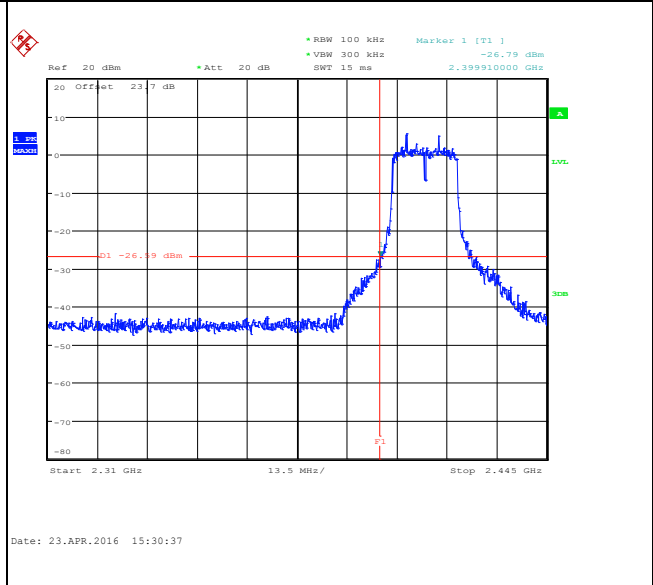

Spurious Emission 30MHz~3GHz

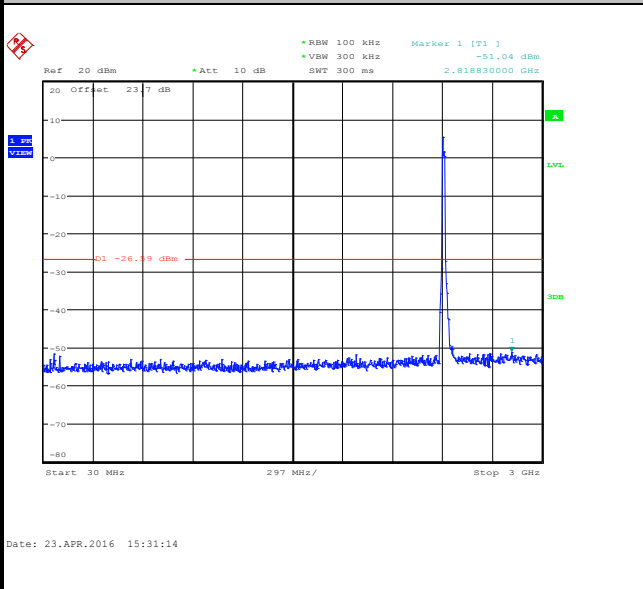

Spurious Emission 2GHz~25GHz

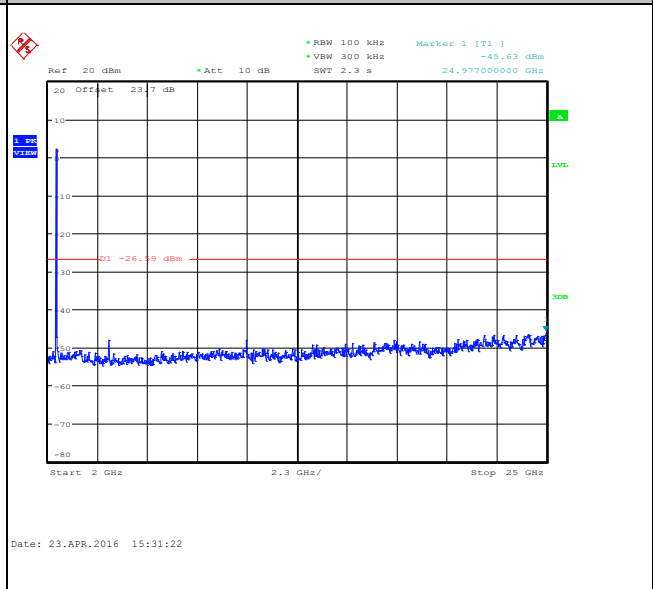



Number of TX :	1	Ant. :	1
Test Mode :	802.11ac VHT20	Temperature :	21~25°C
Test Band :	2.4GHz Mid	Relative Humidity :	51~54%
Test Channel :	06	Test Engineer :	Luffy Lin

WLAN 802.11ac VHT20 Channel 06

100kHz PSD reference Level

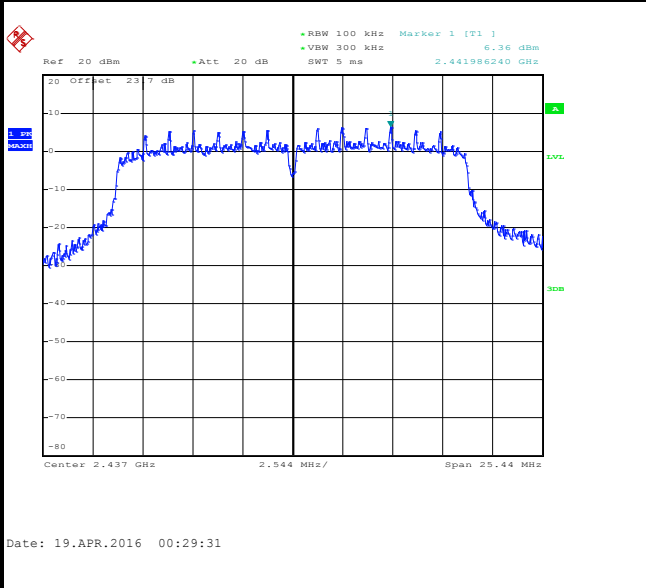

Spurious Emission 30MHz~3GHz

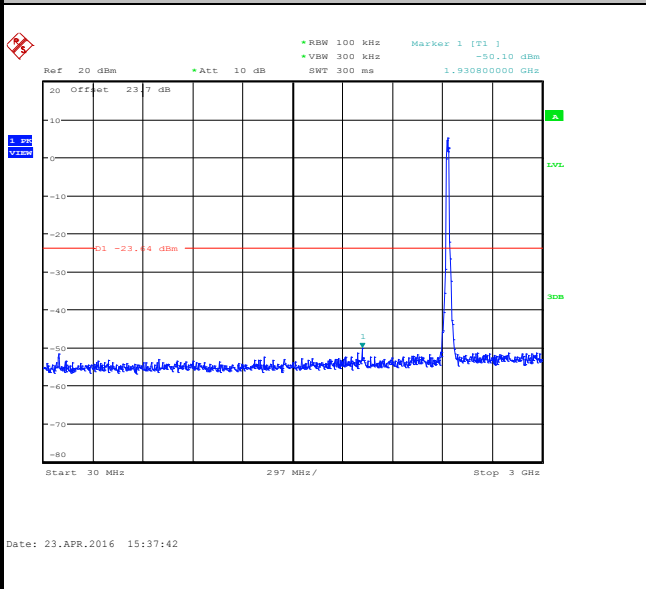

Spurious Emission 2GHz~25GHz

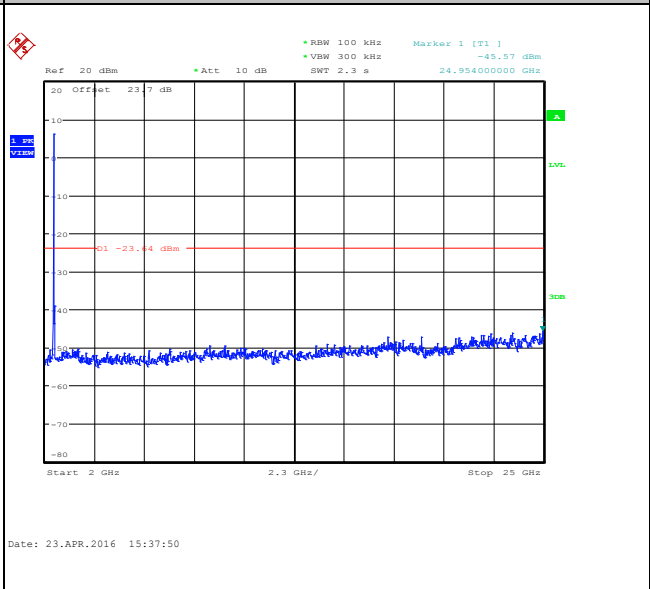



Number of TX :	1	Ant. :	1
Test Mode :	802.11ac VHT20	Temperature :	21~25°C
Test Band :	2.4GHz High	Relative Humidity :	51~54%
Test Channel :	11	Test Engineer :	Luffy Lin

WLAN 802.11ac VHT20 Channel 11

100kHz PSD reference Level



High Channel Plot

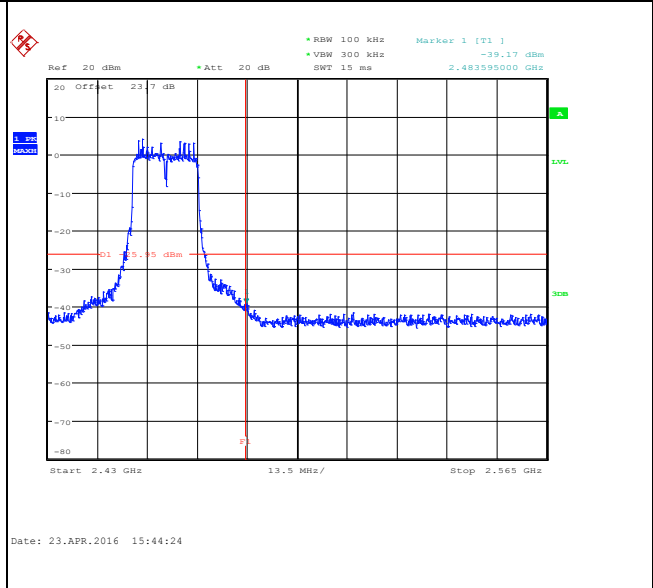

Spurious Emission 30MHz~3GHz

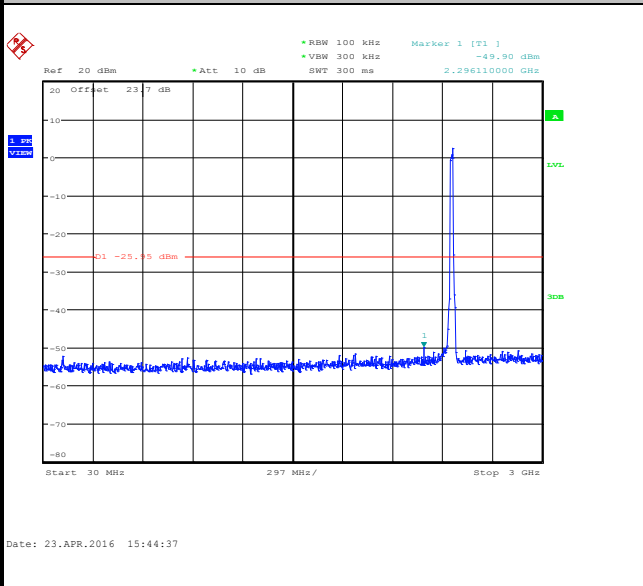

Spurious Emission 2GHz~25GHz

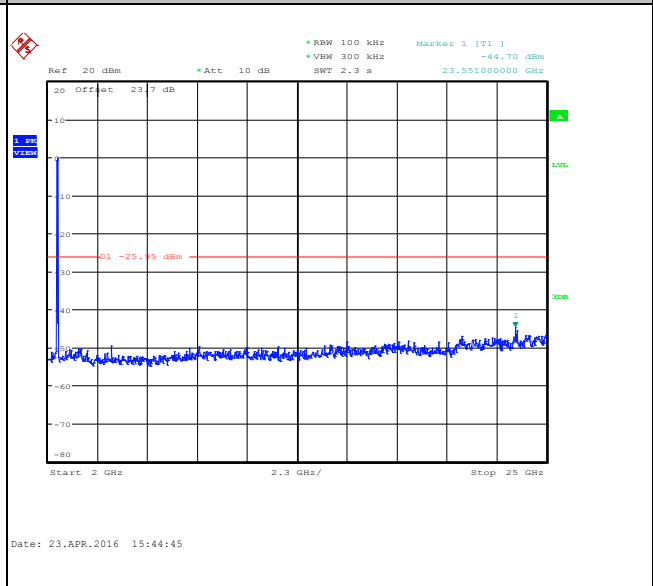



Number of TX = 1, Ant. 2 (Measured)

Number of TX	1	Ant. :	2
Test Mode :	802.11b	Temperature :	21~25°C
Test Band :	2.4GHz Low	Relative Humidity :	51~54%
Test Channel :	01	Test Engineer :	Luffy Lin

WLAN 802.11b Channel 01

100kHz PSD reference Level

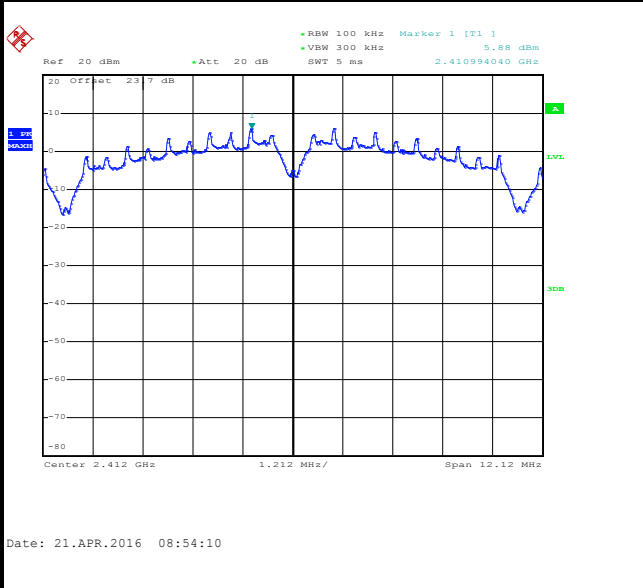

Low Channel Plot

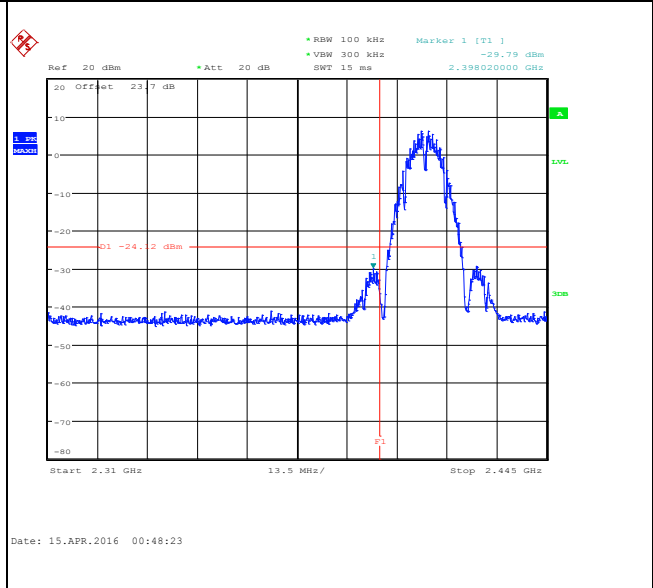

Spurious Emission 30MHz~3GHz

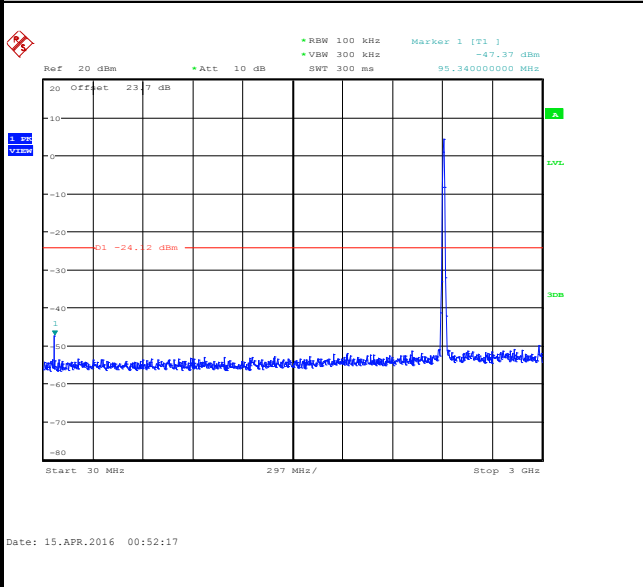

Spurious Emission 2GHz~25GHz

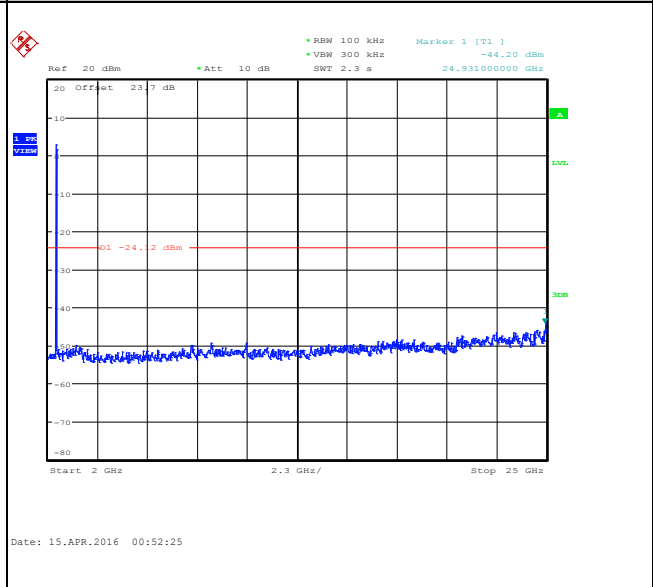



Number of TX :	1	Ant. :	2
Test Mode :	802.11b	Temperature :	21~25°C
Test Band :	2.4GHz Mid	Relative Humidity :	51~54%
Test Channel :	06	Test Engineer :	Luffy Lin

WLAN 802.11b Channel 06

100kHz PSD reference Level

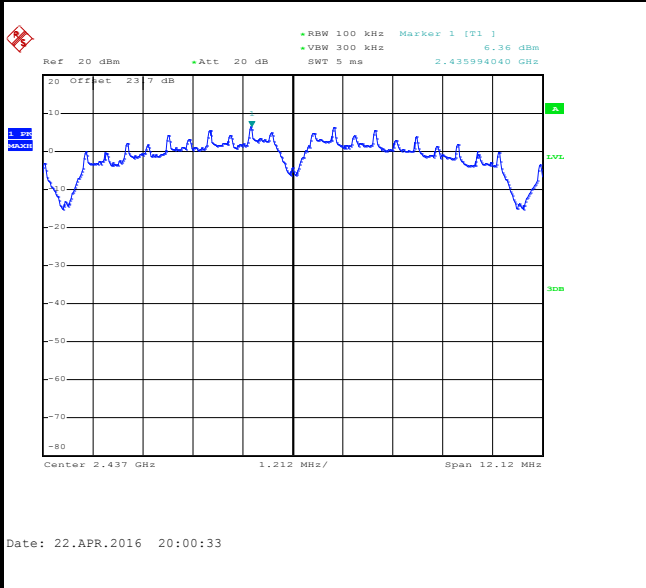

Spurious Emission 30MHz~3GHz

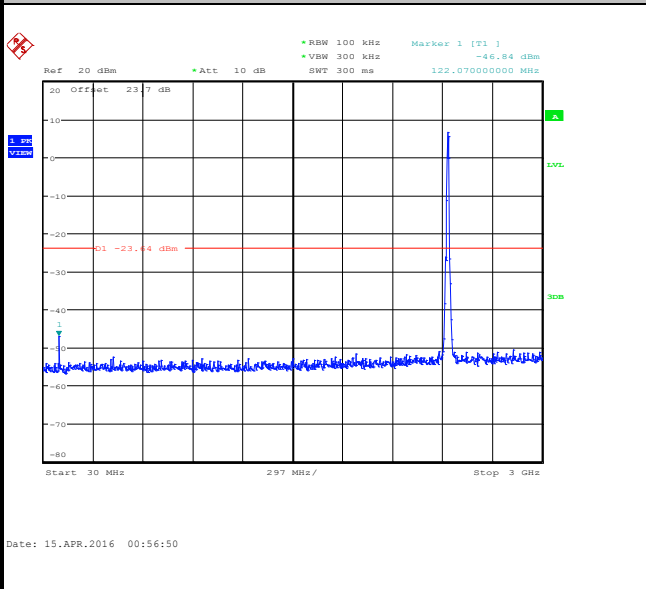

Spurious Emission 2GHz~25GHz

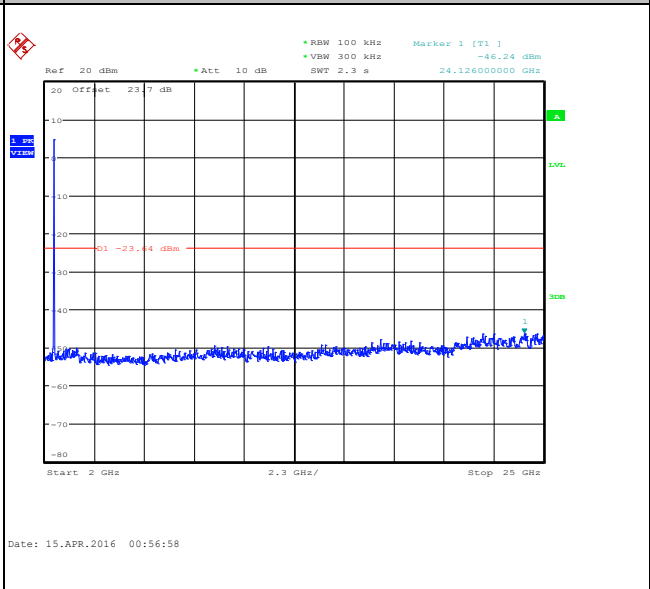



Number of TX :	1	Ant. :	2
Test Mode :	802.11b	Temperature :	21~25°C
Test Band :	2.4GHz High	Relative Humidity :	51~54%
Test Channel :	11	Test Engineer :	Luffy Lin

WLAN 802.11b Channel 11

100kHz PSD reference Level

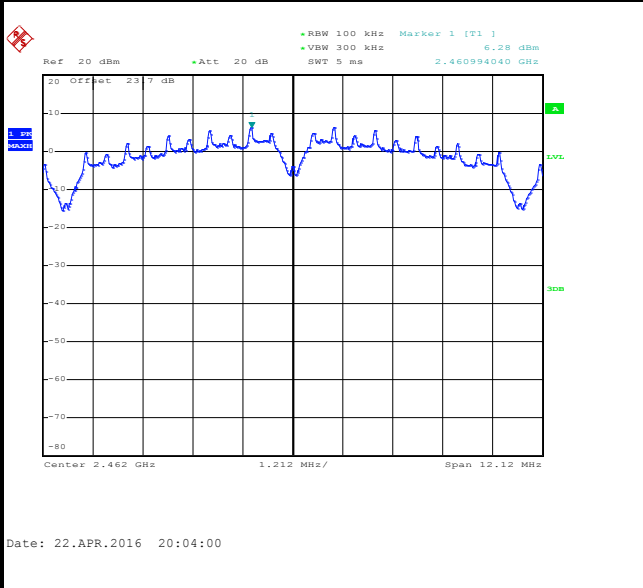

High Channel Plot

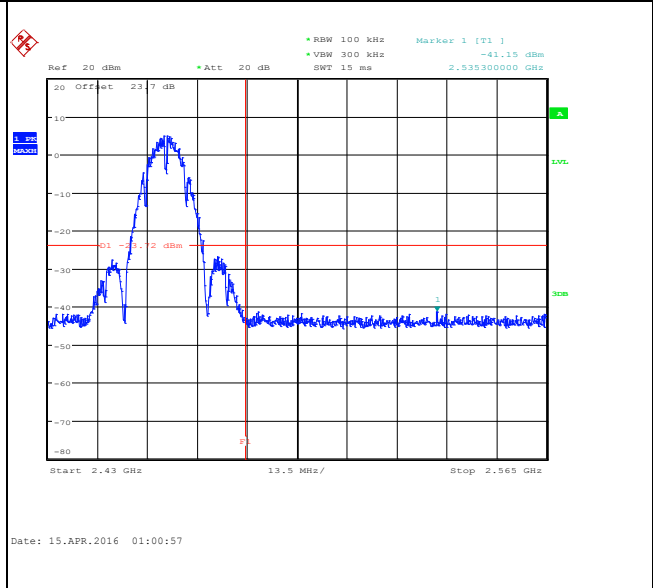

Spurious Emission 30MHz~3GHz

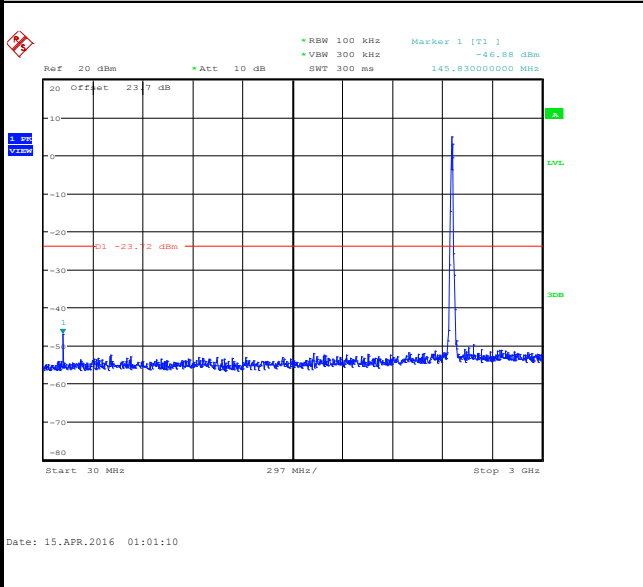

Spurious Emission 2GHz~25GHz

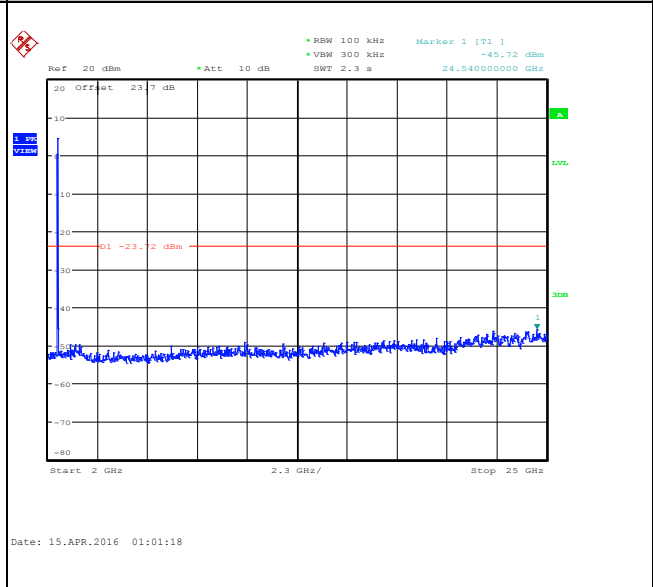



Number of TX :	1	Ant. :	2
Test Mode :	802.11g	Temperature :	21~25°C
Test Band :	2.4GHz Low	Relative Humidity :	51~54%
Test Channel :	01	Test Engineer :	Luffy Lin

WLAN 802.11g Channel 01

100kHz PSD reference Level

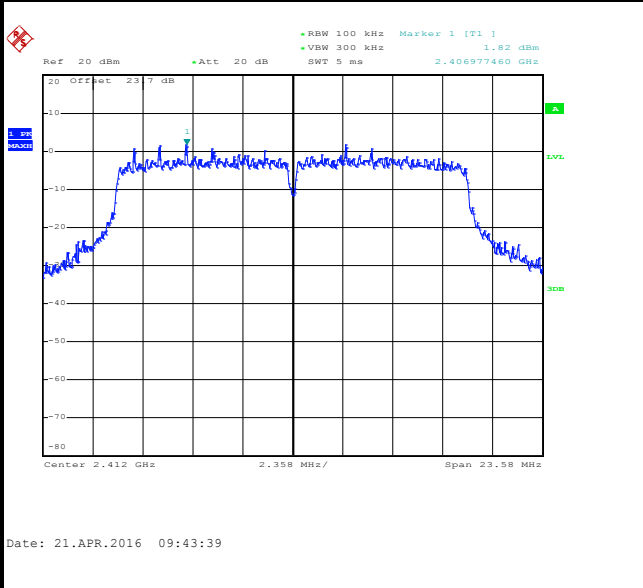

Low Channel Plot

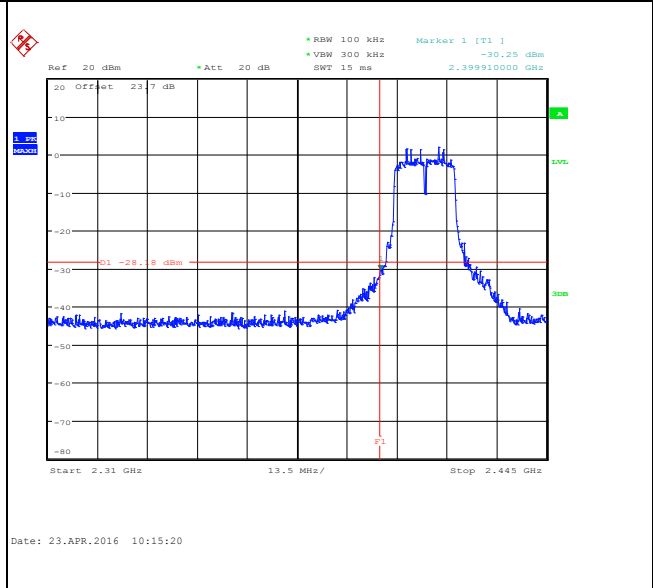

Spurious Emission 30MHz~3GHz

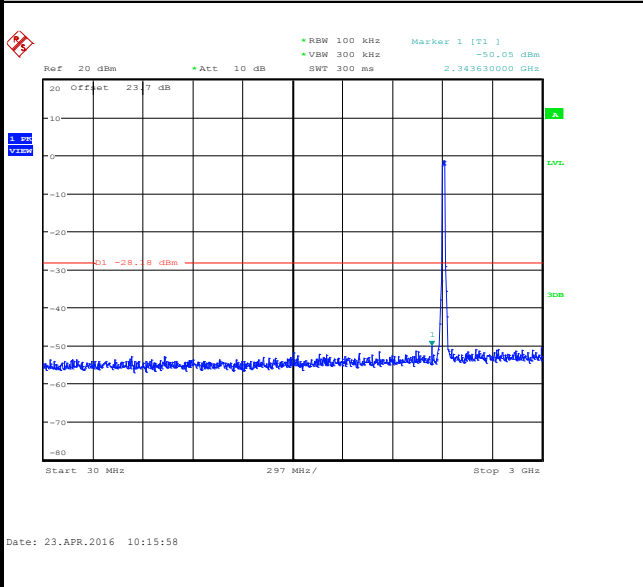

Spurious Emission 2GHz~25GHz

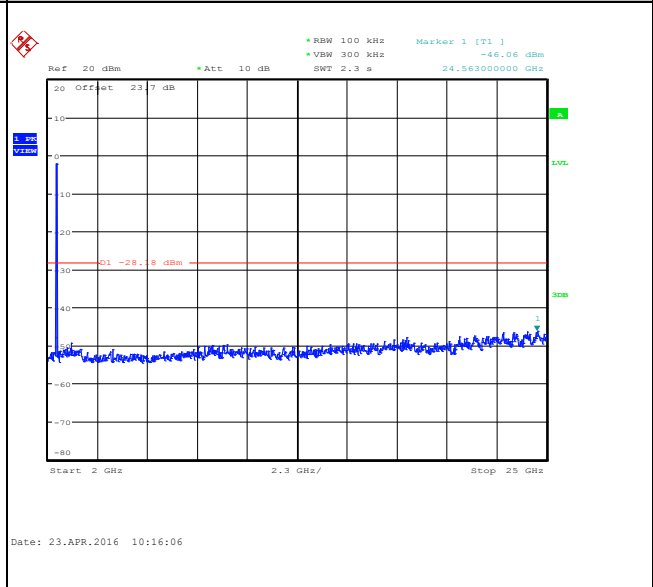



Number of TX :	1	Ant. :	2
Test Mode :	802.11g	Temperature :	21~25°C
Test Band :	2.4GHz Mid	Relative Humidity :	51~54%
Test Channel :	06	Test Engineer :	Luffy Lin

WLAN 802.11g Channel 06

100kHz PSD reference Level

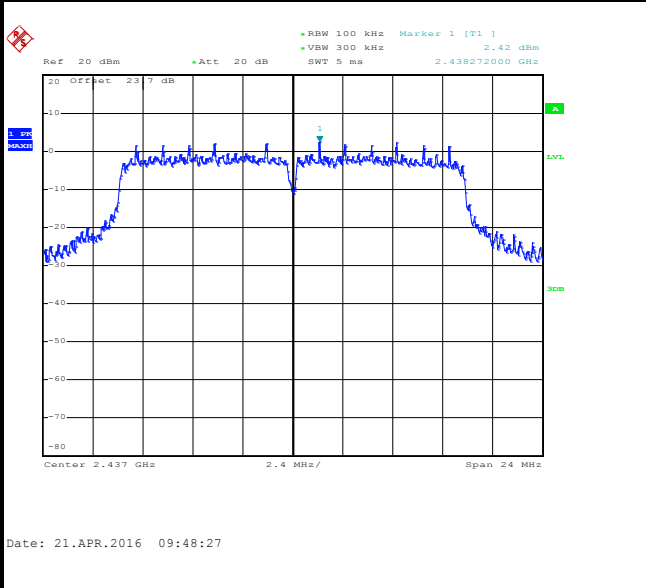

Spurious Emission 30MHz~3GHz

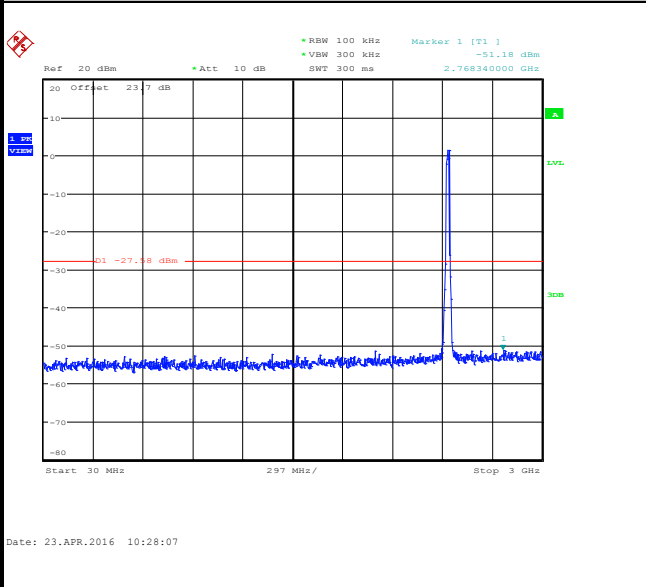

Spurious Emission 2GHz~25GHz

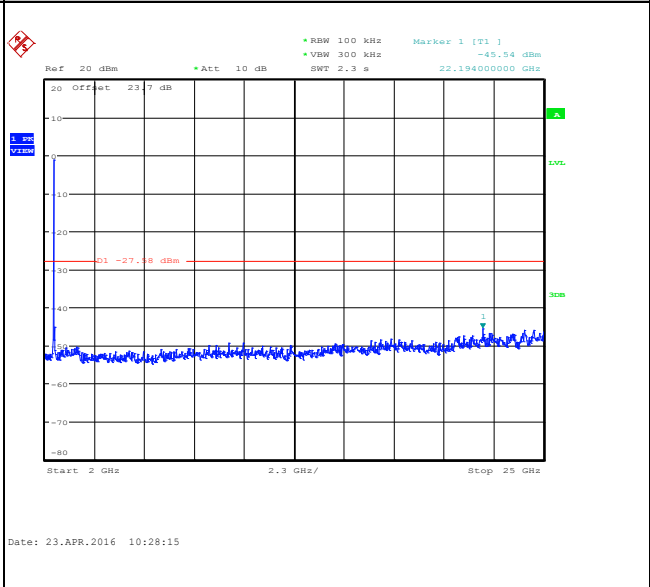



Number of TX :	1	Ant. :	2
Test Mode :	802.11g	Temperature :	21~25°C
Test Band :	2.4GHz High	Relative Humidity :	51~54%
Test Channel :	11	Test Engineer :	Luffy Lin

WLAN 802.11g Channel 11

100kHz PSD reference Level

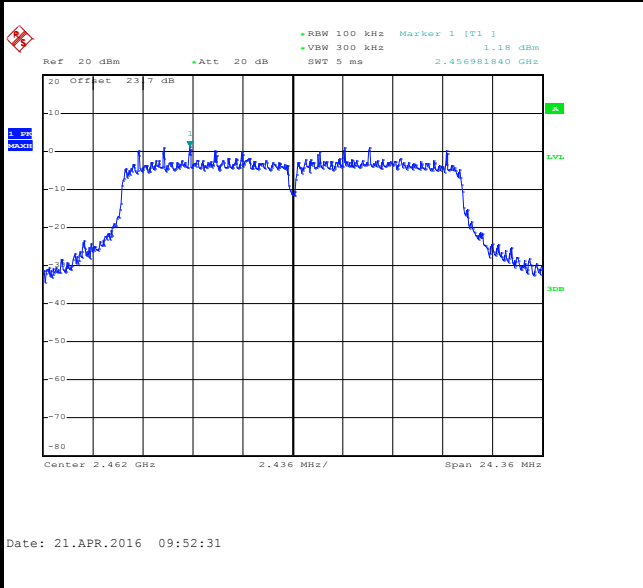

High Channel Plot

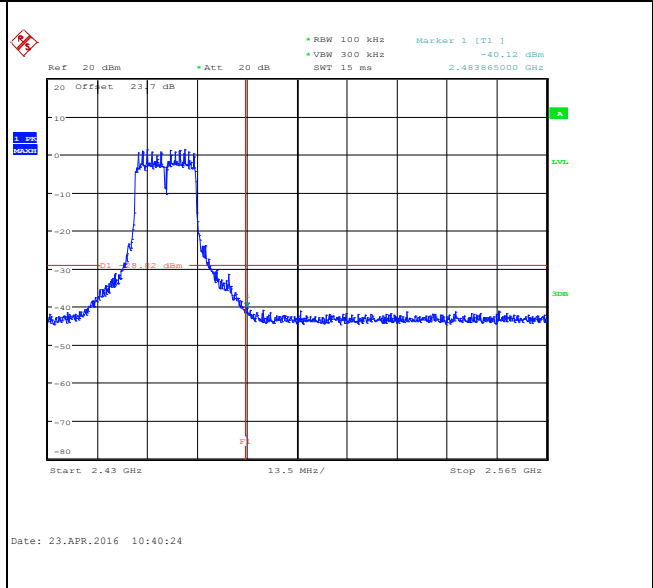

Spurious Emission 30MHz~3GHz

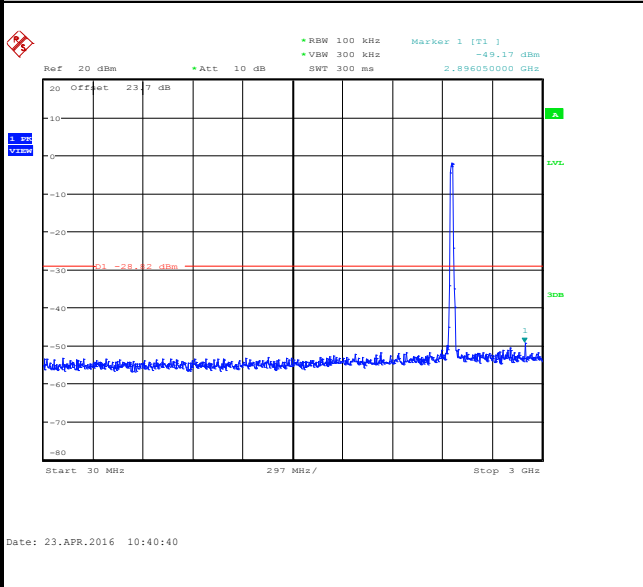

Spurious Emission 2GHz~25GHz

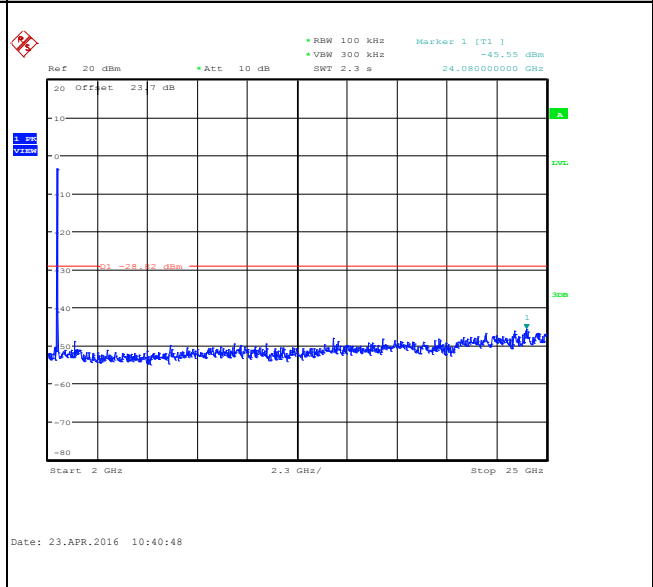



Number of TX :	1	Ant. :	2
Test Mode :	802.11n HT20	Temperature :	21~25°C
Test Band :	2.4GHz Low	Relative Humidity :	51~54%
Test Channel :	01	Test Engineer :	Luffy Lin

WLAN 802.11n HT20 Channel 01

100kHz PSD reference Level

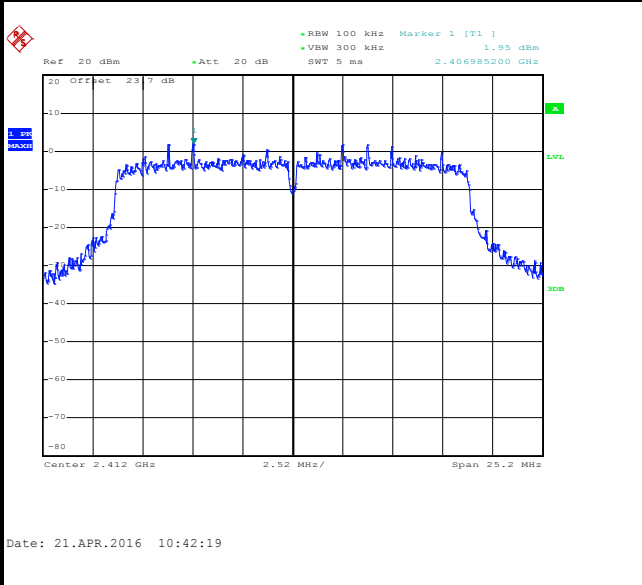

Low Channel Plot

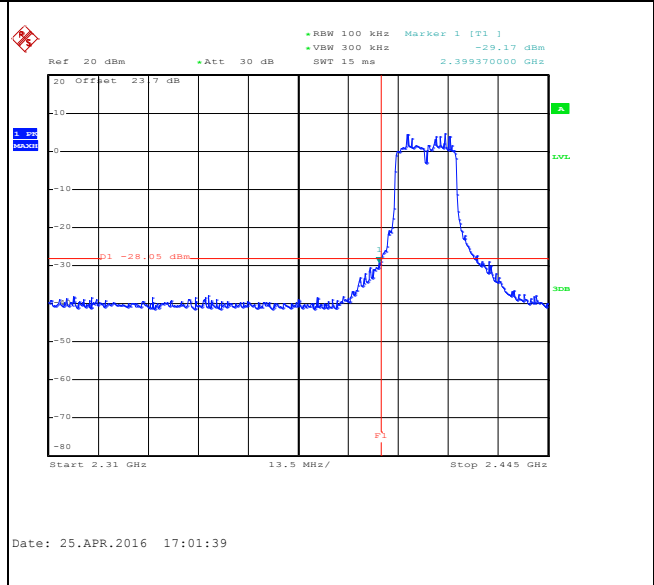

Spurious Emission 30MHz~3GHz

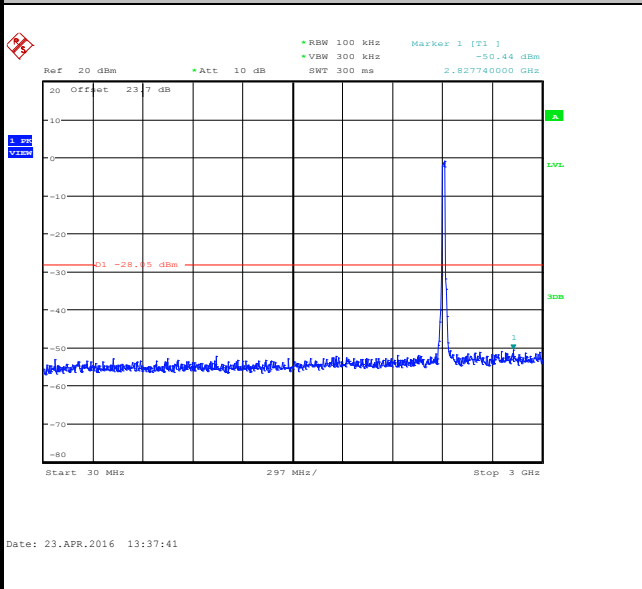

Spurious Emission 2GHz~25GHz

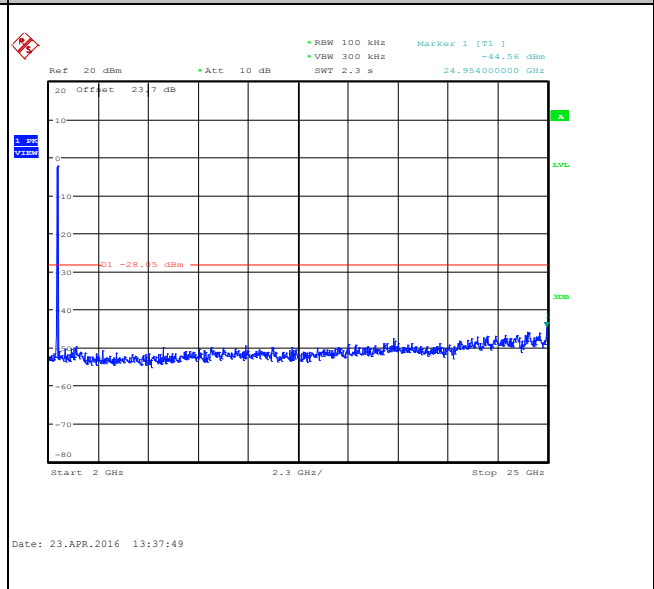



Number of TX :	1	Ant. :	2
Test Mode :	802.11n HT20	Temperature :	21~25°C
Test Band :	2.4GHz Mid	Relative Humidity :	51~54%
Test Channel :	06	Test Engineer :	Luffy Lin

WLAN 802.11n HT20 Channel 06

100kHz PSD reference Level

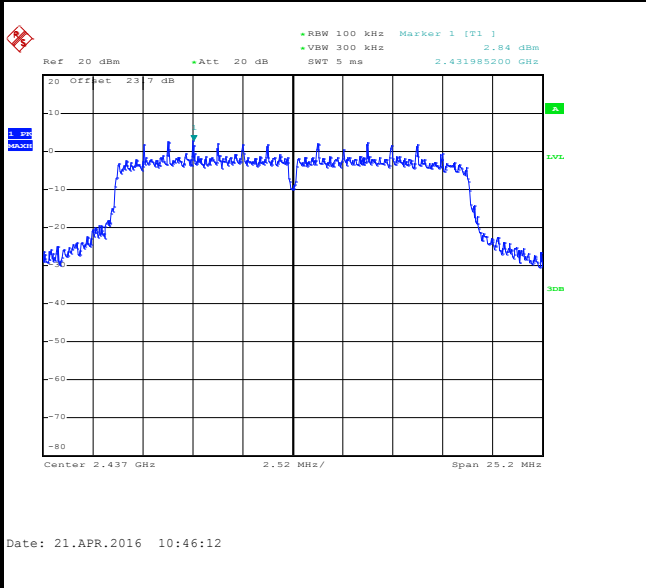

Spurious Emission 30MHz~3GHz

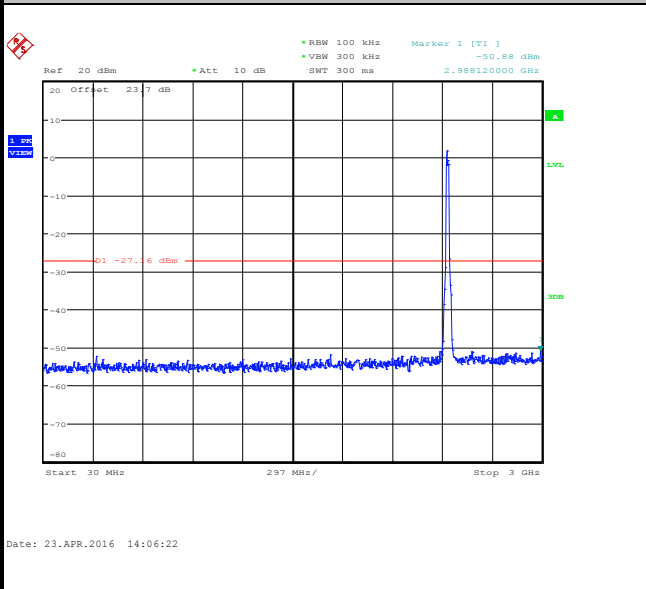

Spurious Emission 2GHz~25GHz

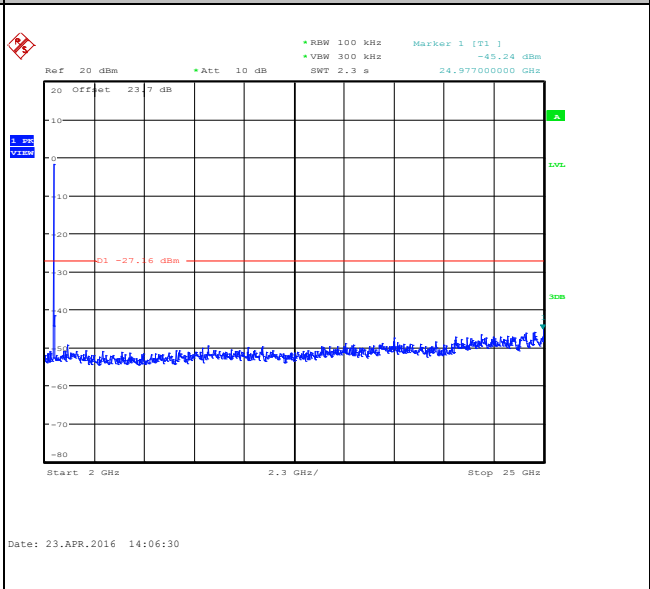



Number of TX :	1	Ant. :	2
Test Mode :	802.11n HT20	Temperature :	21~25°C
Test Band :	2.4GHz High	Relative Humidity :	51~54%
Test Channel :	11	Test Engineer :	Luffy Lin

WLAN 802.11n HT20 Channel 11

100kHz PSD reference Level

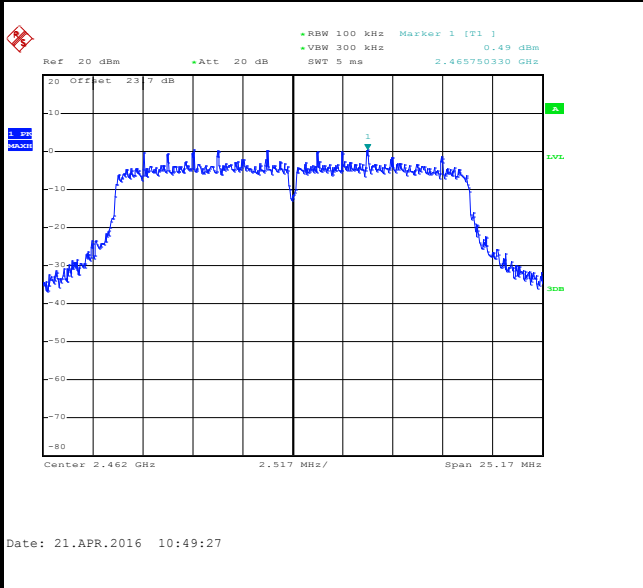

High Channel Plot

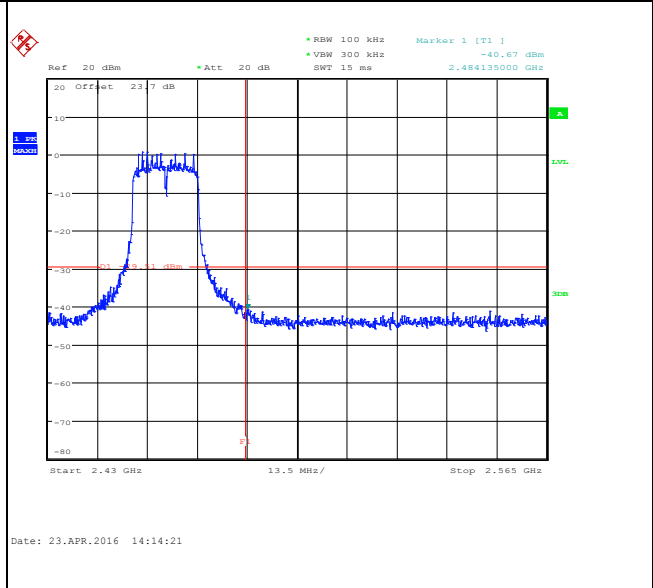

Spurious Emission 30MHz~3GHz

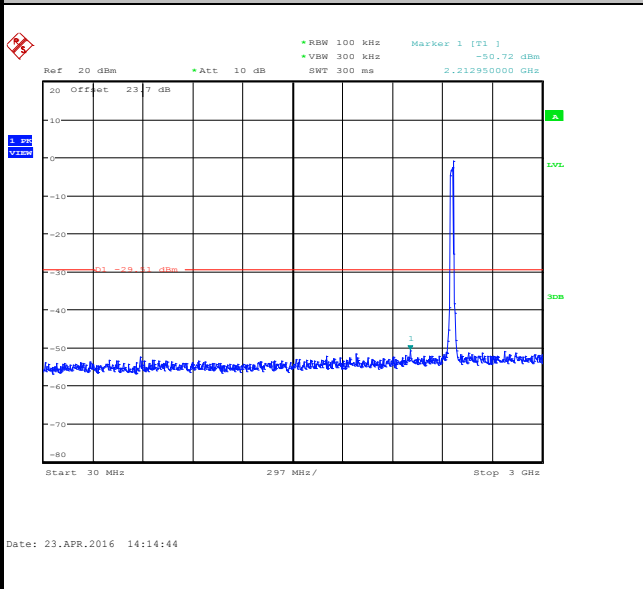

Spurious Emission 2GHz~25GHz

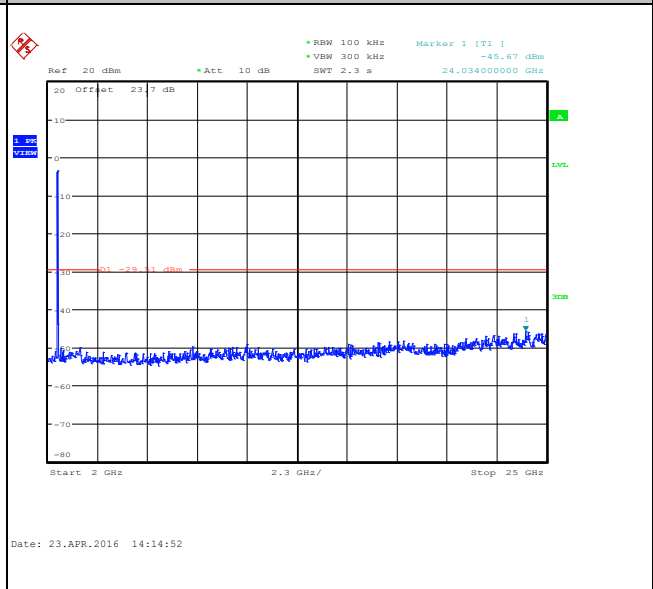



Number of TX :	1	Ant. :	2
Test Mode :	802.11ac VHT20	Temperature :	21~25°C
Test Band :	2.4GHz Low	Relative Humidity :	51~54%
Test Channel :	01	Test Engineer :	Luffy Lin

WLAN 802.11ac VHT20 Channel 01

100kHz PSD reference Level

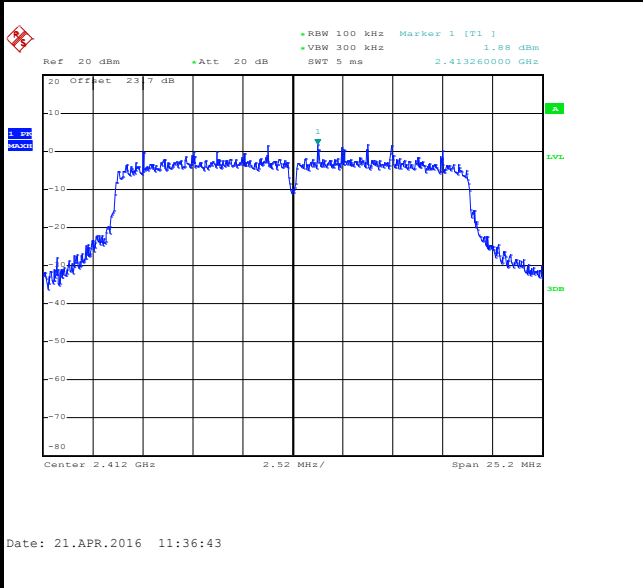

Low Channel Plot

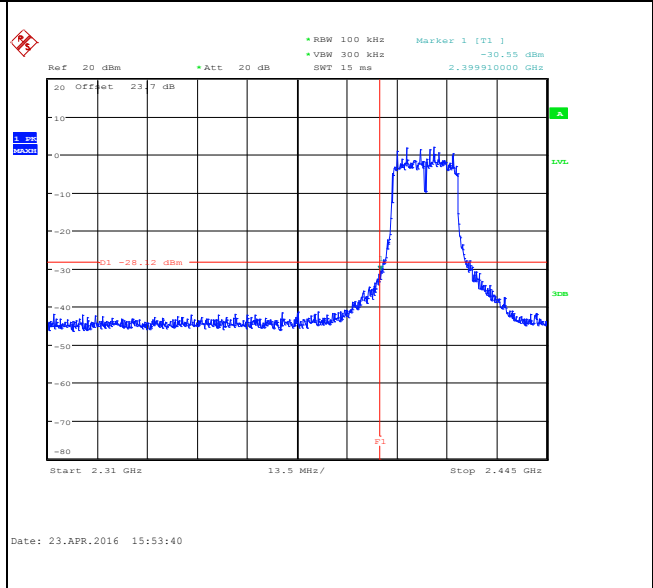

Spurious Emission 30MHz~3GHz

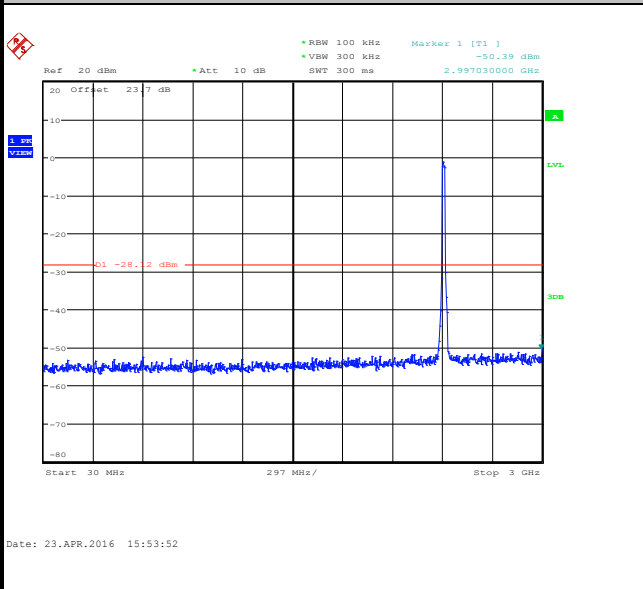

Spurious Emission 2GHz~25GHz

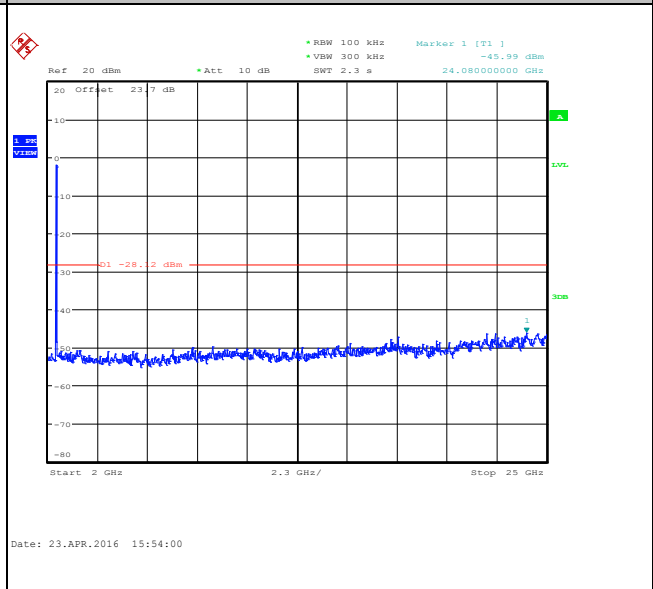



Number of TX :	1	Ant. :	2
Test Mode :	802.11ac VHT20	Temperature :	21~25°C
Test Band :	2.4GHz Mid	Relative Humidity :	51~54%
Test Channel :	06	Test Engineer :	Luffy Lin

WLAN 802.11ac VHT20 Channel 06

100kHz PSD reference Level

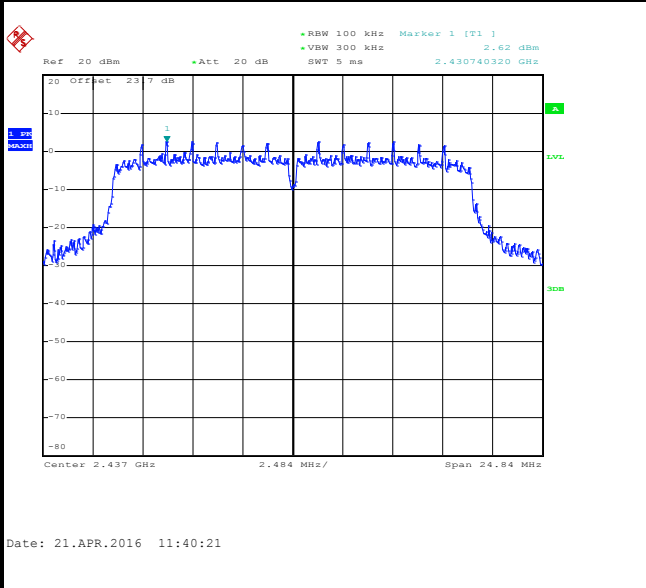

Spurious Emission 30MHz~3GHz

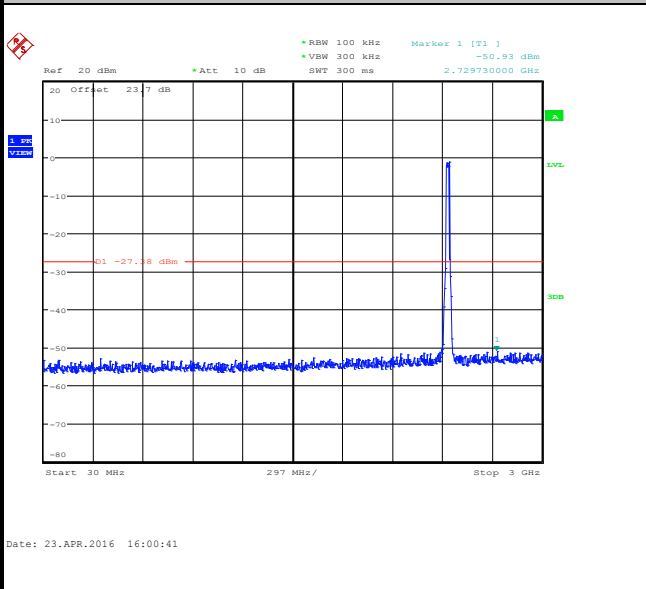

Spurious Emission 2GHz~25GHz

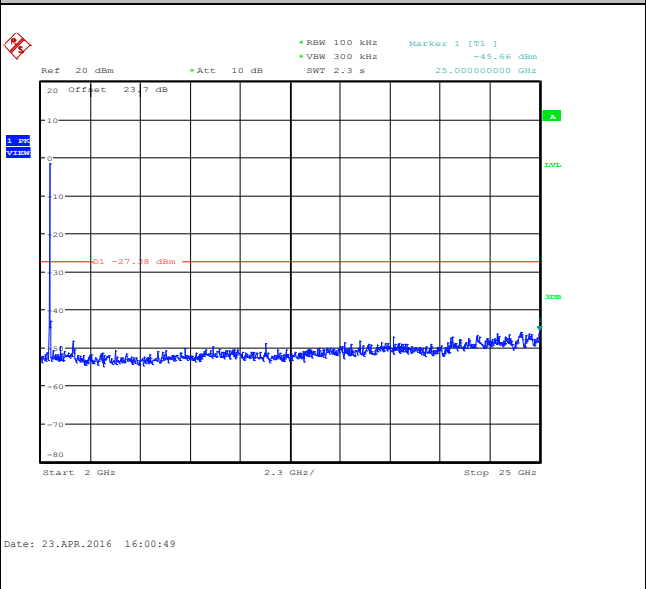



Number of TX :	1	Ant. :	2
Test Mode :	802.11ac VHT20	Temperature :	21~25°C
Test Band :	2.4GHz High	Relative Humidity :	51~54%
Test Channel :	11	Test Engineer :	Luffy Lin

WLAN 802.11ac VHT20 Channel 11

100kHz PSD reference Level

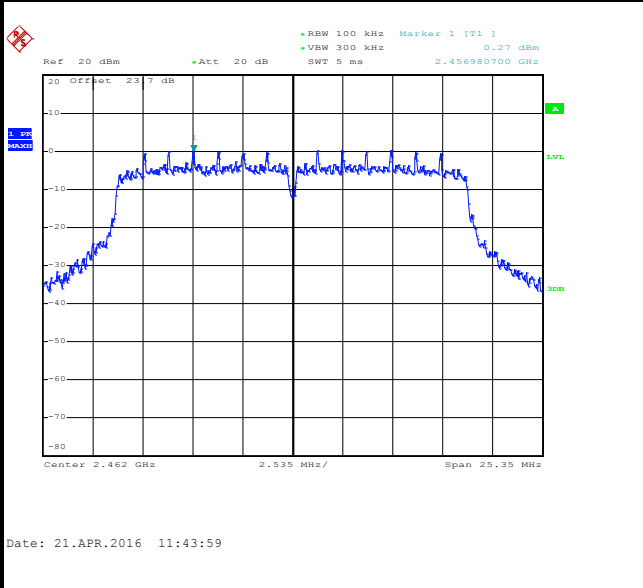

High Channel Plot

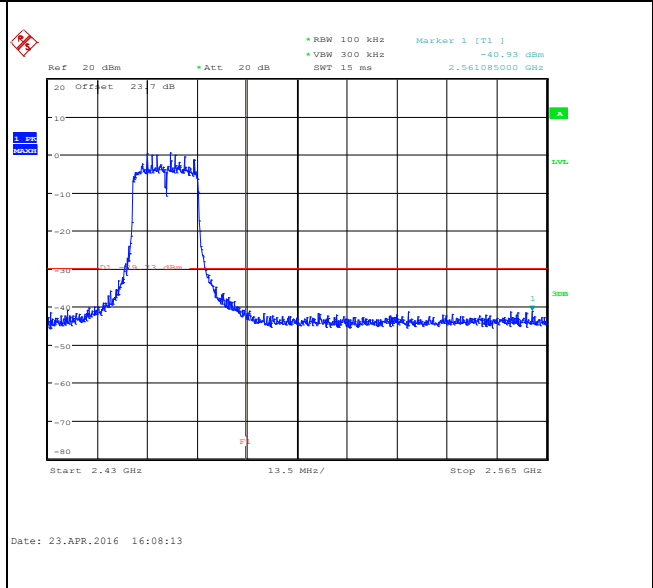

Spurious Emission 30MHz~3GHz

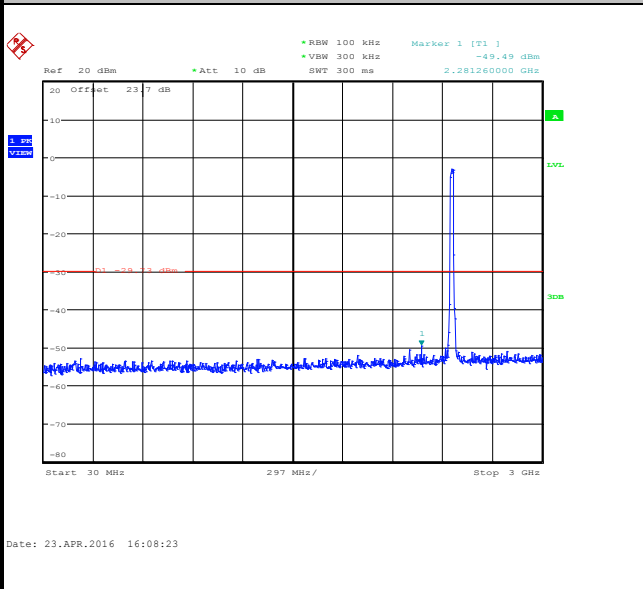

Spurious Emission 2GHz~25GHz

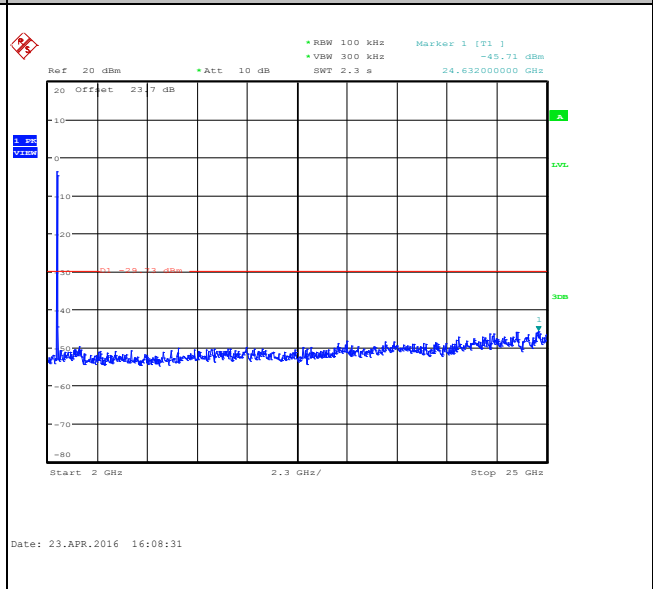



Number of TX = 2, Ant. 1 (Measured)

Number of TX	2	Ant. :	1
Test Mode :	802.11b	Temperature :	21~25°C
Test Band :	2.4GHz Low	Relative Humidity :	51~54%
Test Channel :	01	Test Engineer :	Luffy Lin

WLAN 802.11b Channel 01

100kHz PSD reference Level

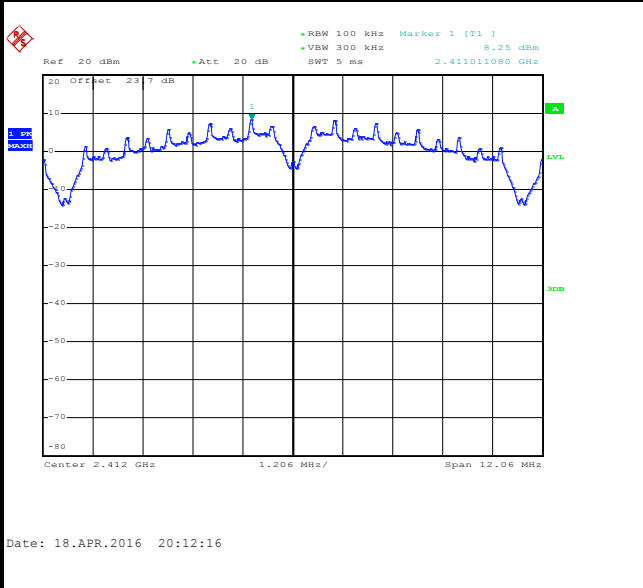

Low Channel Plot

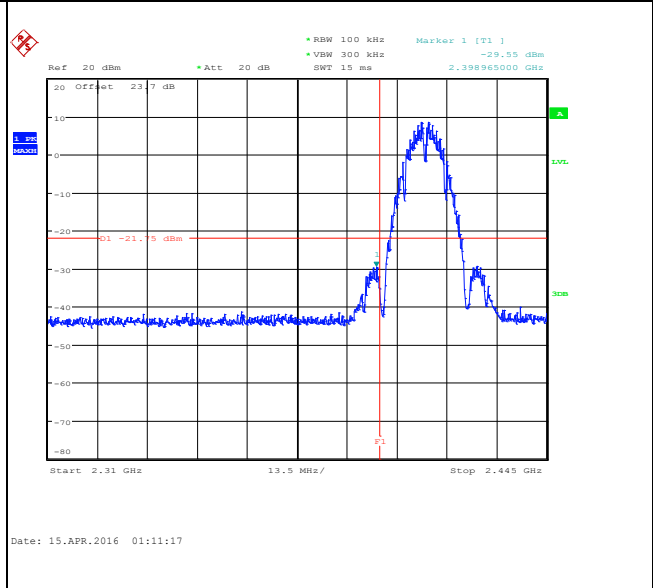

Spurious Emission 30MHz~3GHz

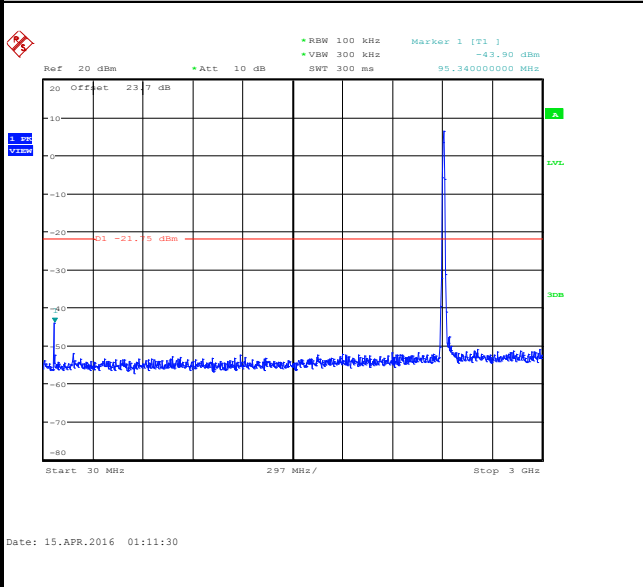

Spurious Emission 2GHz~25GHz

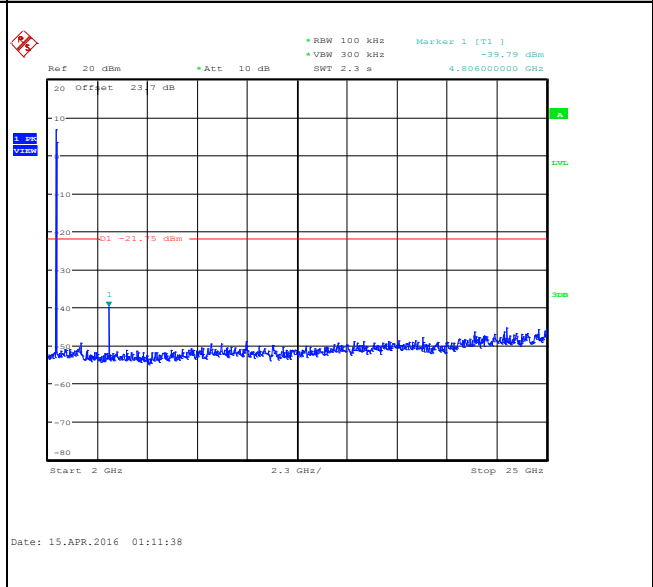



Number of TX :	2	Ant. :	1
Test Mode :	802.11b	Temperature :	21~25°C
Test Band :	2.4GHz Mid	Relative Humidity :	51~54%
Test Channel :	06	Test Engineer :	Luffy Lin

WLAN 802.11b Channel 06

100kHz PSD reference Level

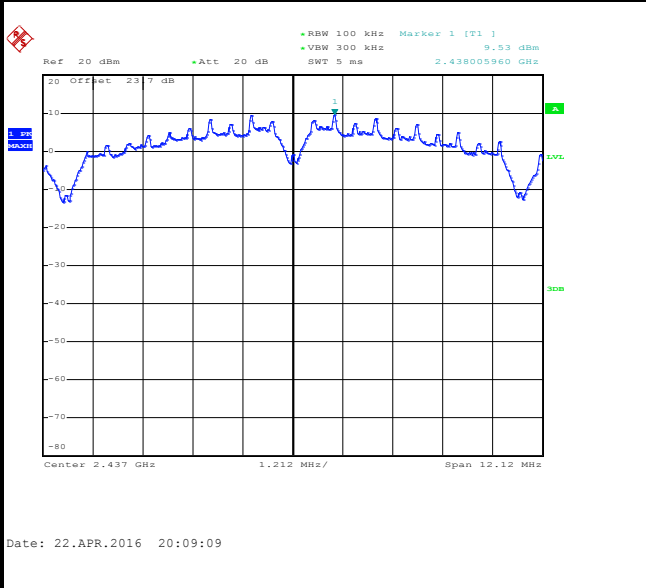

Spurious Emission 30MHz~3GHz

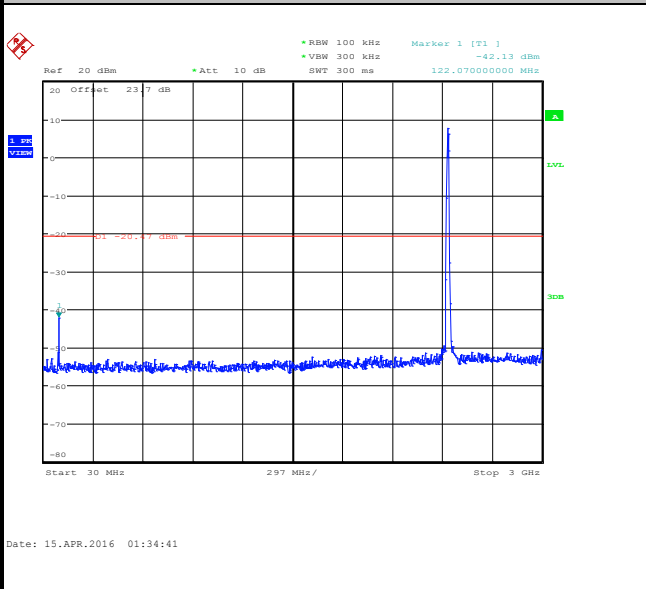

Spurious Emission 2GHz~25GHz

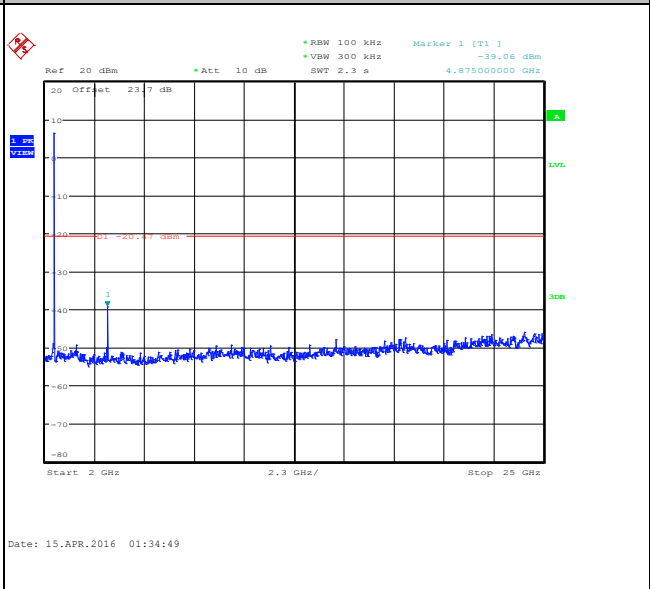



Number of TX :	2	Ant. :	1
Test Mode :	802.11b	Temperature :	21~25°C
Test Band :	2.4GHz High	Relative Humidity :	51~54%
Test Channel :	11	Test Engineer :	Luffy Lin

WLAN 802.11b Channel 11

100kHz PSD reference Level

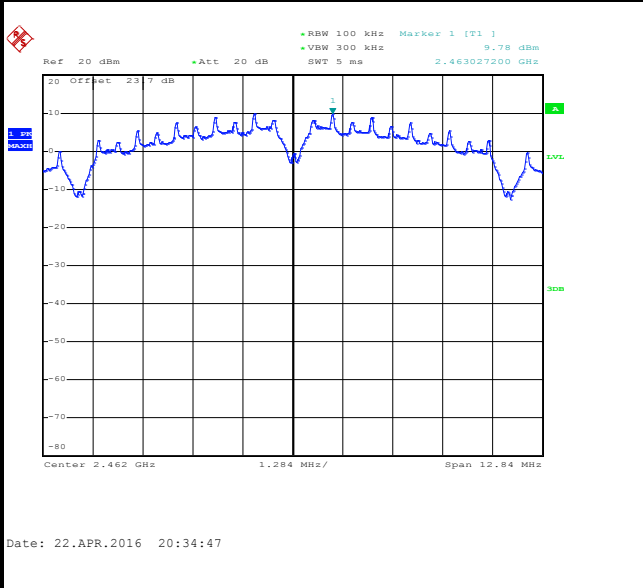

High Channel Plot

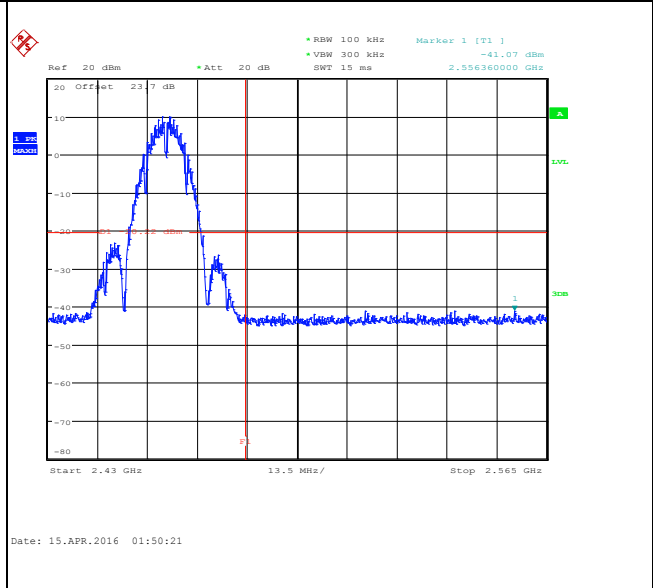

Spurious Emission 30MHz~3GHz

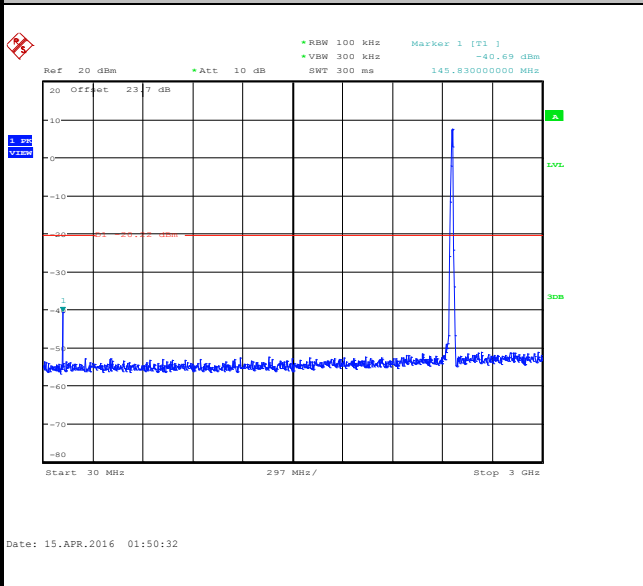

Spurious Emission 2GHz~25GHz

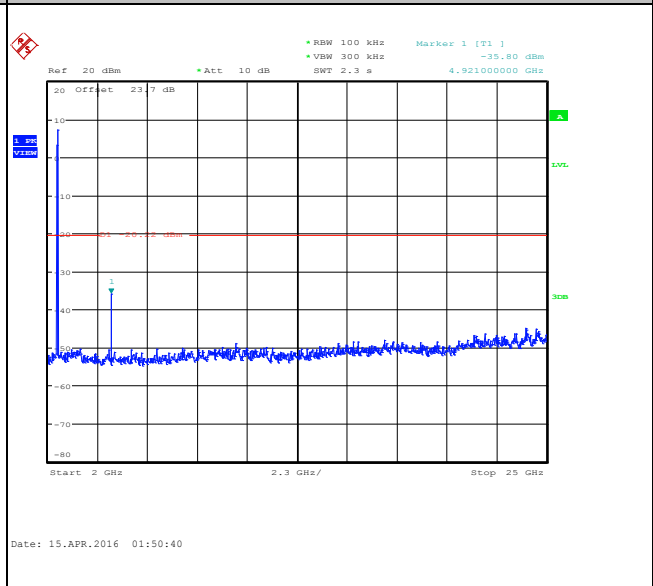



Number of TX :	2	Ant. :	1
Test Mode :	802.11g	Temperature :	21~25°C
Test Band :	2.4GHz Low	Relative Humidity :	51~54%
Test Channel :	01	Test Engineer :	Luffy Lin

WLAN 802.11g Channel 01

100kHz PSD reference Level

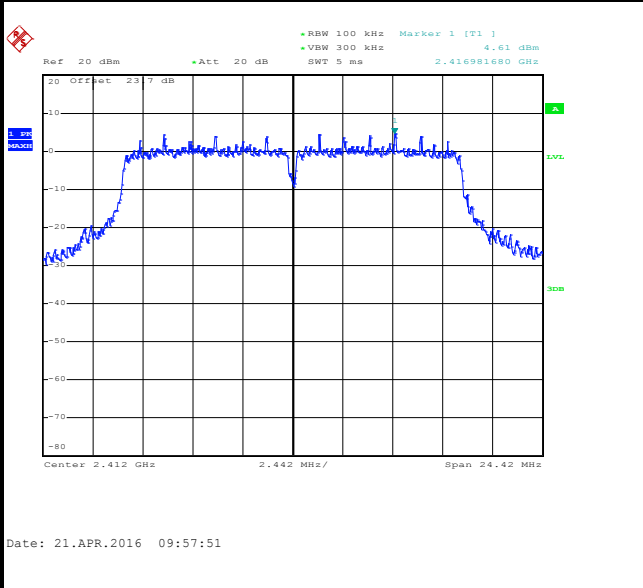

Low Channel Plot

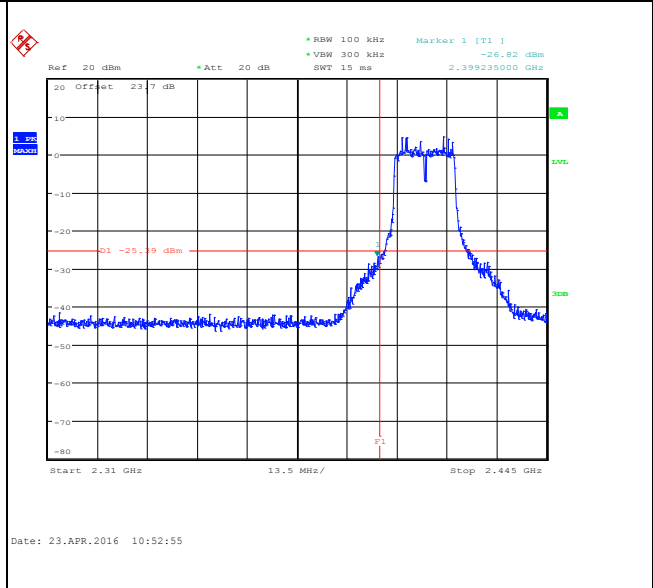

Spurious Emission 30MHz~3GHz

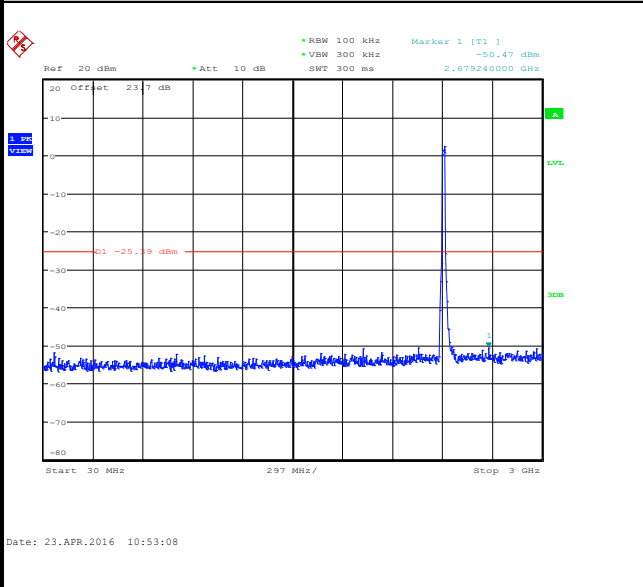

Spurious Emission 2GHz~25GHz

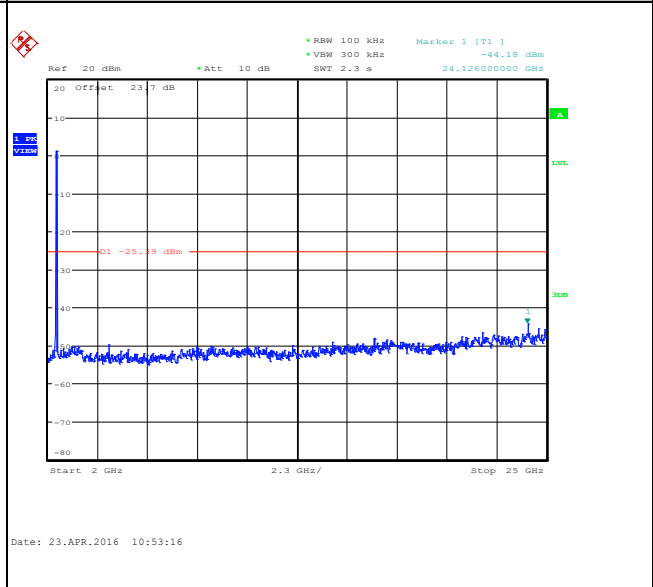



Number of TX :	2	Ant. :	1
Test Mode :	802.11g	Temperature :	21~25°C
Test Band :	2.4GHz Mid	Relative Humidity :	51~54%
Test Channel :	06	Test Engineer :	Luffy Lin

WLAN 802.11g Channel 06

100kHz PSD reference Level

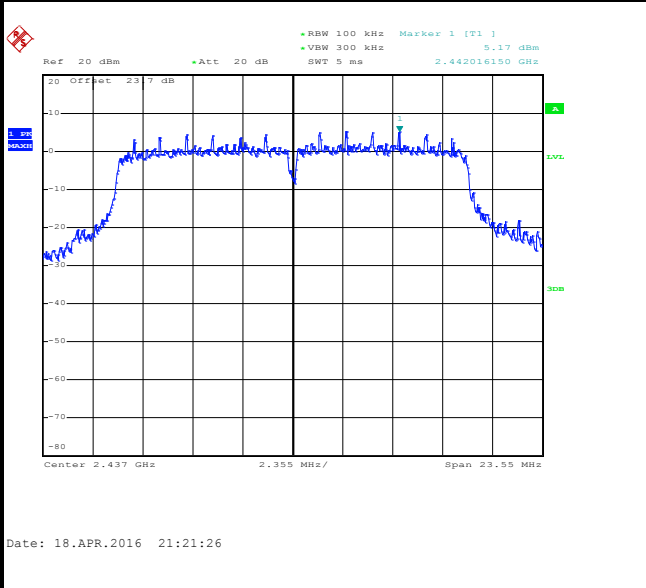

Spurious Emission 30MHz~3GHz

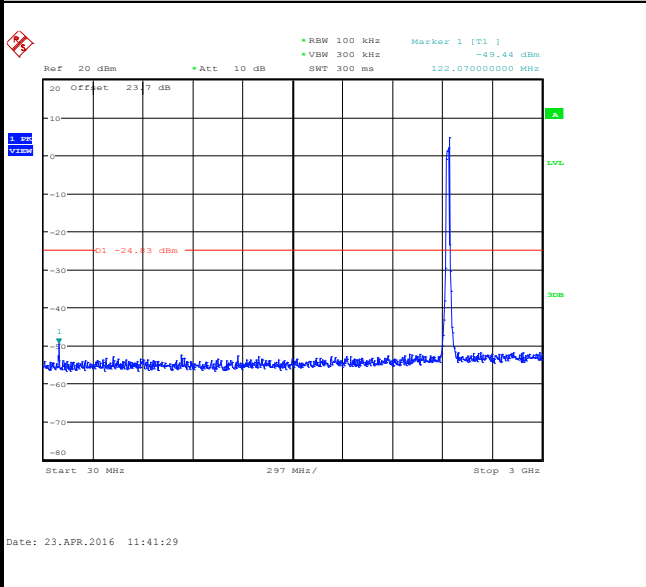

Spurious Emission 2GHz~25GHz

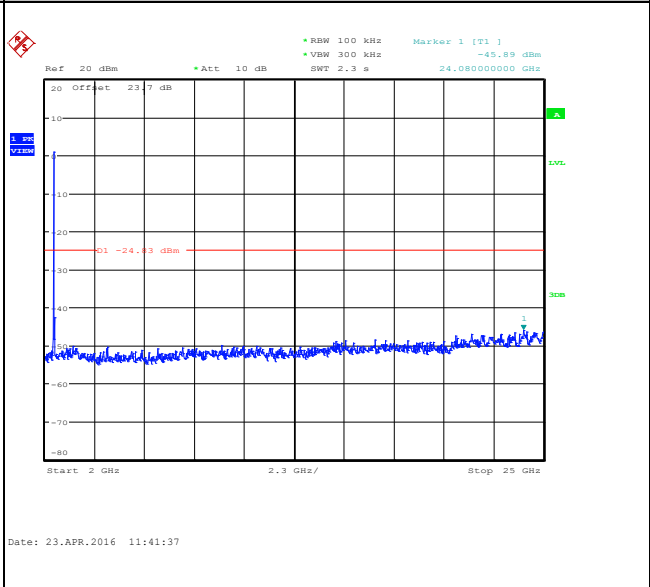



Number of TX :	2	Ant. :	1
Test Mode :	802.11g	Temperature :	21~25°C
Test Band :	2.4GHz High	Relative Humidity :	51~54%
Test Channel :	11	Test Engineer :	Luffy Lin

WLAN 802.11g Channel 11

100kHz PSD reference Level

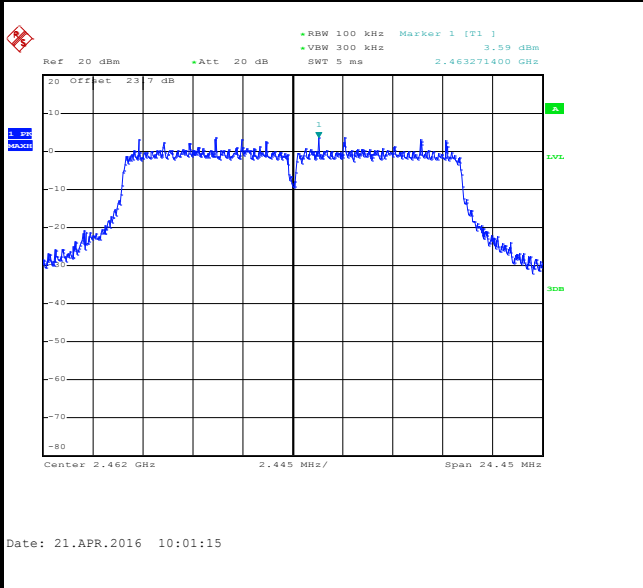

High Channel Plot

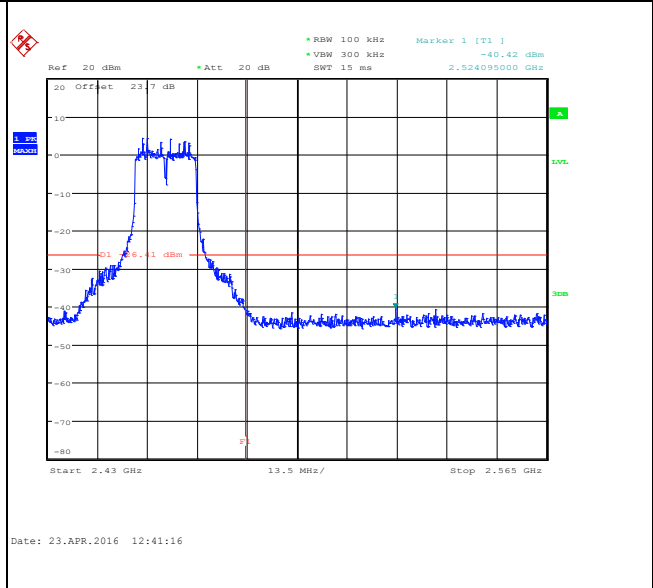

Spurious Emission 30MHz~3GHz

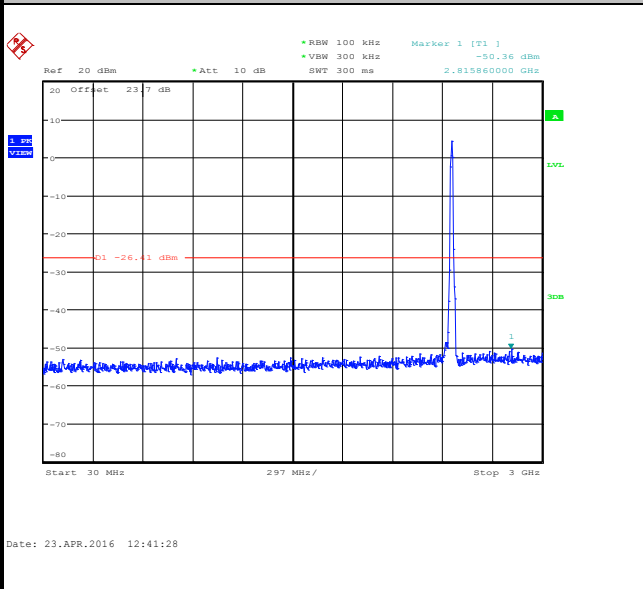

Spurious Emission 2GHz~25GHz

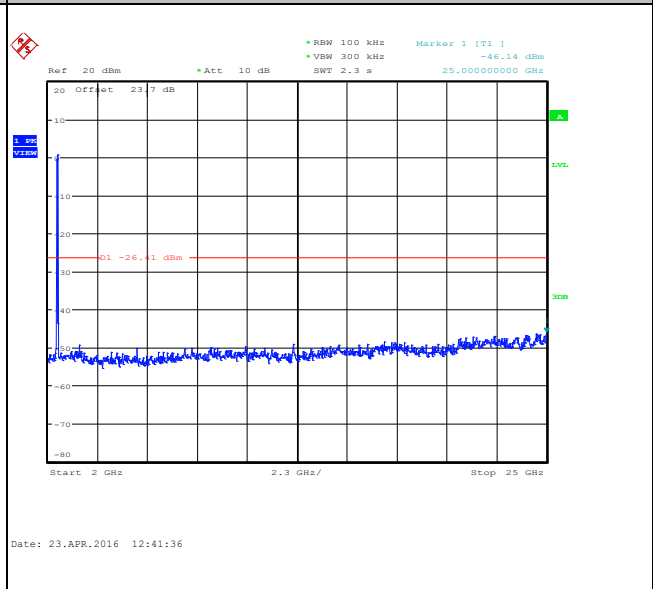



Number of TX :	2	Ant. :	1
Test Mode :	802.11n HT20	Temperature :	21~25°C
Test Band :	2.4GHz Low	Relative Humidity :	51~54%
Test Channel :	01	Test Engineer :	Luffy Lin

WLAN 802.11n HT20 Channel 01

100kHz PSD reference Level

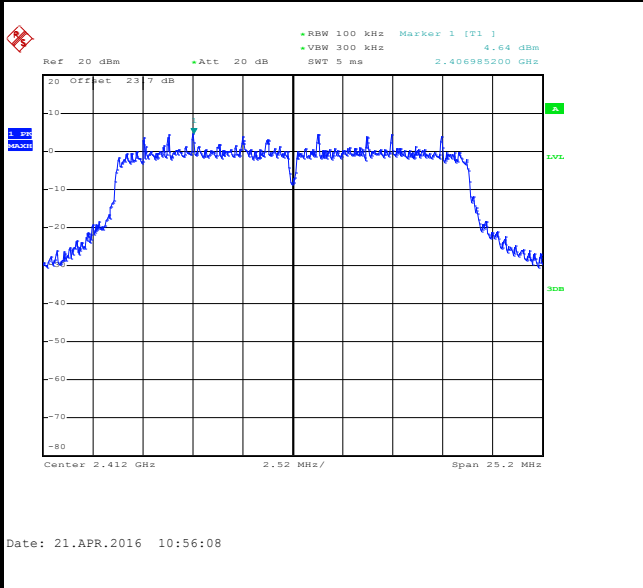

Low Channel Plot

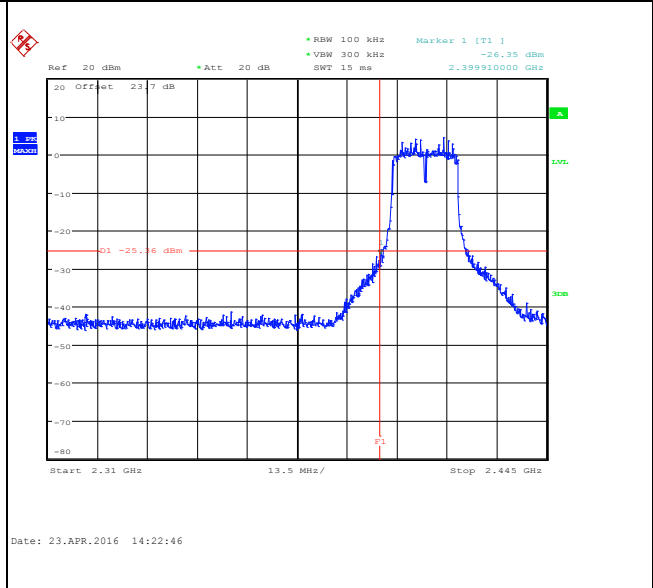

Spurious Emission 30MHz~3GHz

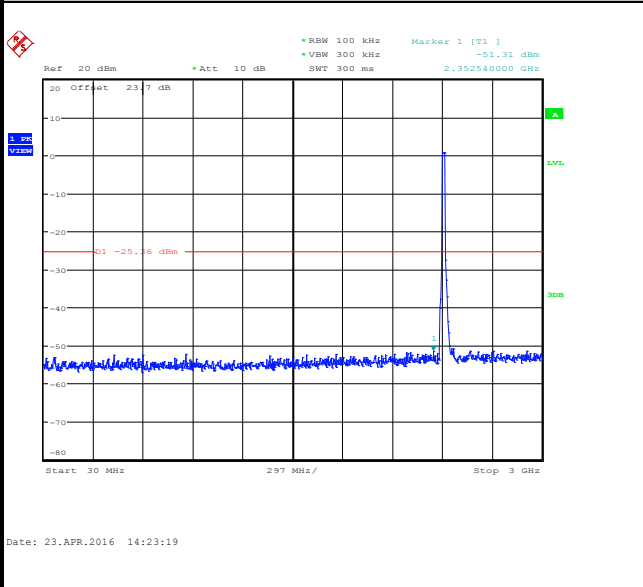

Spurious Emission 2GHz~25GHz

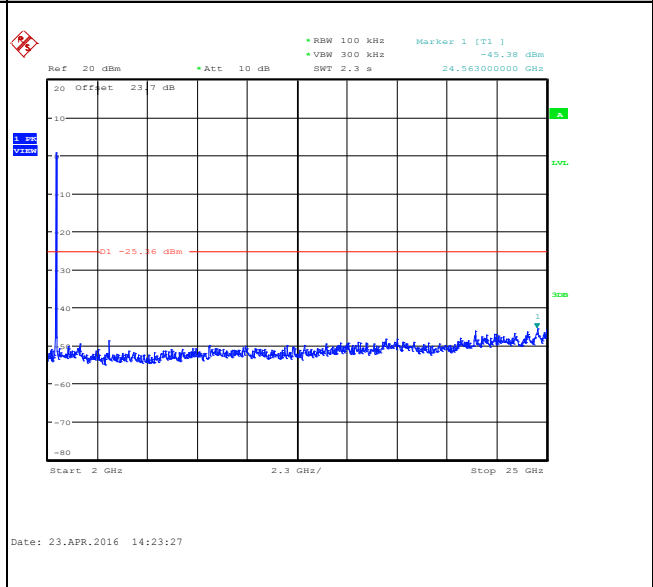



Number of TX :	2	Ant. :	1
Test Mode :	802.11n HT20	Temperature :	21~25°C
Test Band :	2.4GHz Mid	Relative Humidity :	51~54%
Test Channel :	06	Test Engineer :	Luffy Lin

WLAN 802.11n HT20 Channel 06

100kHz PSD reference Level

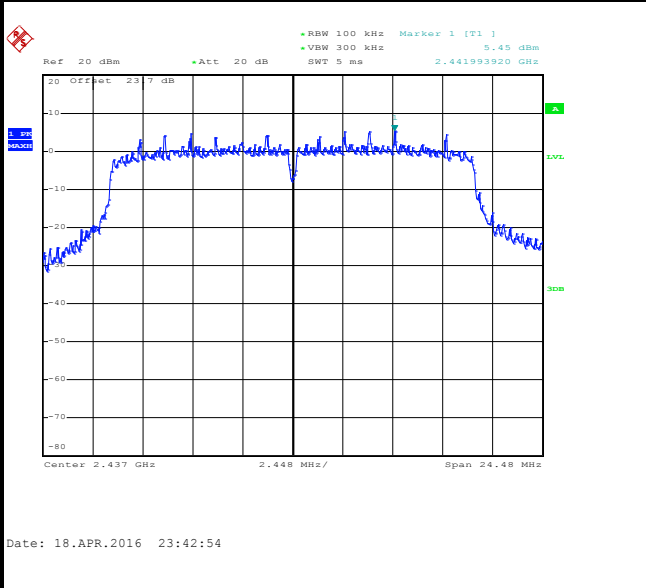

Spurious Emission 30MHz~3GHz

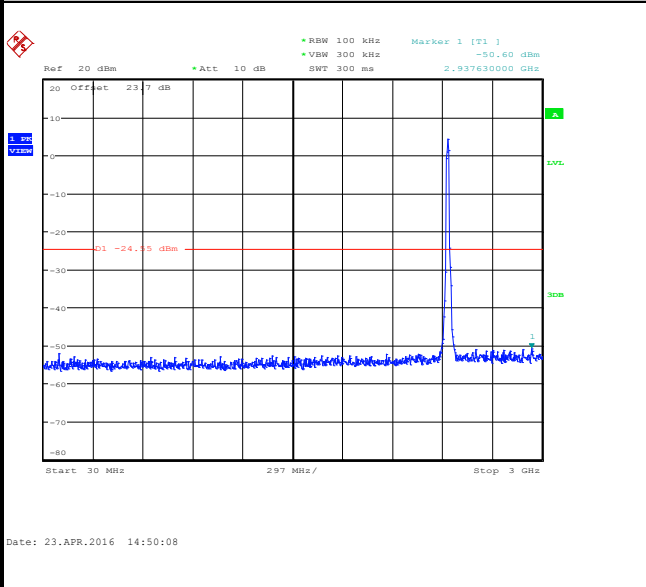

Spurious Emission 2GHz~25GHz

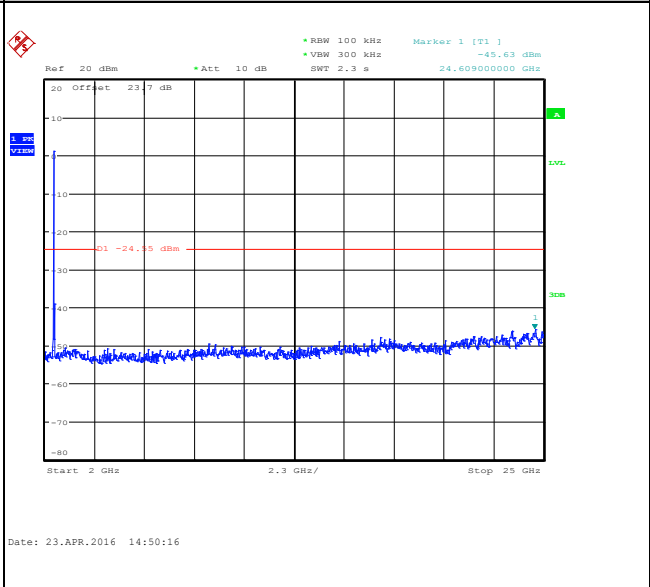



Number of TX :	2	Ant. :	1
Test Mode :	802.11n HT20	Temperature :	21~25°C
Test Band :	2.4GHz High	Relative Humidity :	51~54%
Test Channel :	11	Test Engineer :	Luffy Lin

WLAN 802.11n HT20 Channel 11

100kHz PSD reference Level

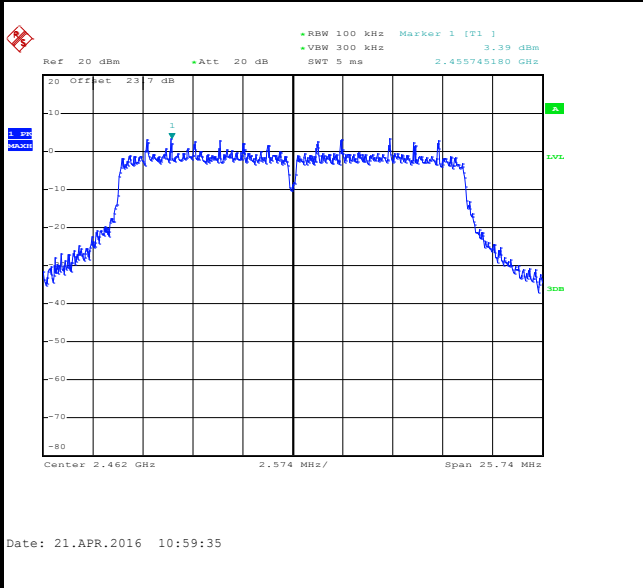

High Channel Plot

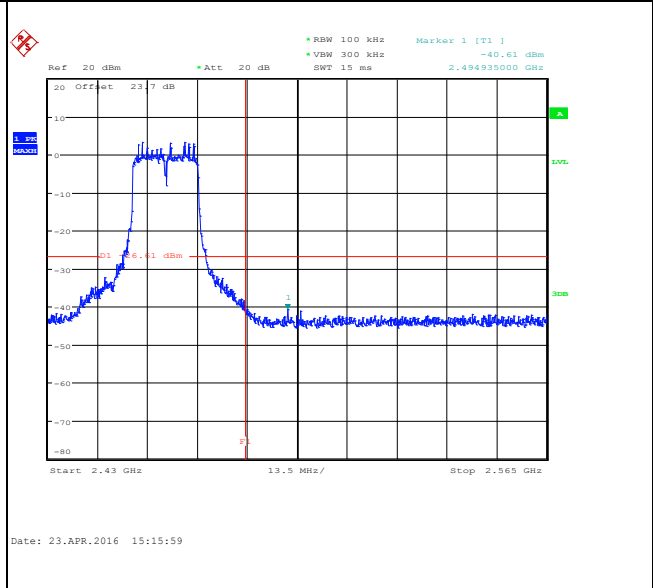

Spurious Emission 30MHz~3GHz

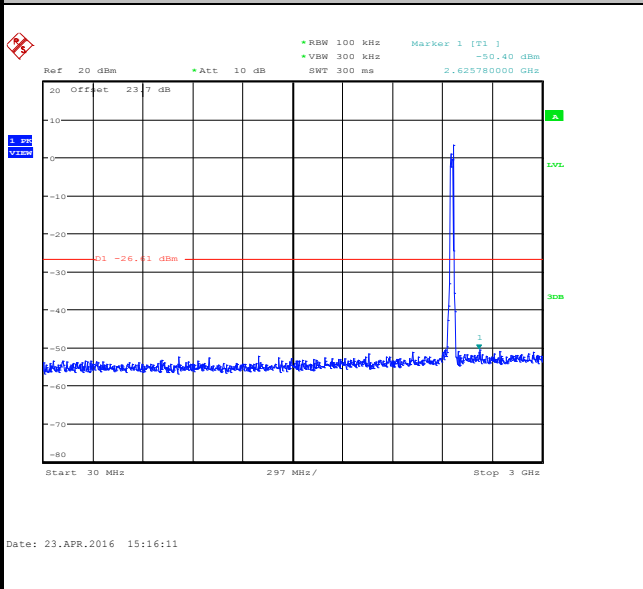

Spurious Emission 2GHz~25GHz

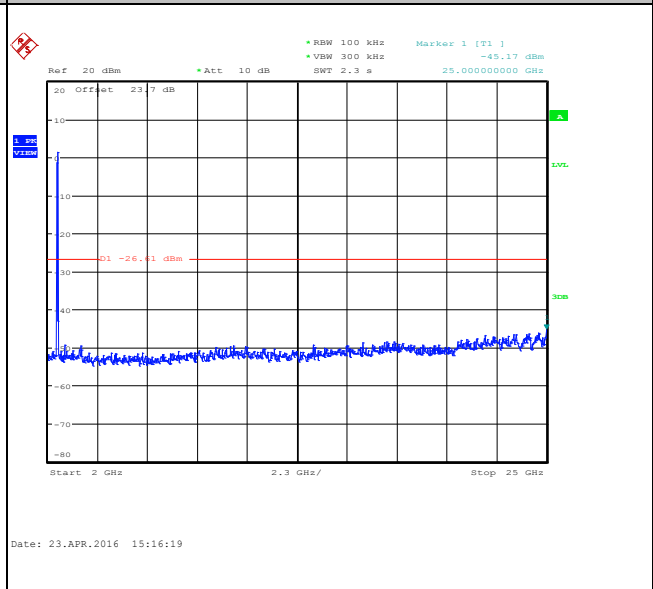



Number of TX :	2	Ant. :	1
Test Mode :	802.11ac VHT20	Temperature :	21~25°C
Test Band :	2.4GHz Low	Relative Humidity :	51~54%
Test Channel :	01	Test Engineer :	Luffy Lin

WLAN 802.11ac VHT20 Channel 01

100kHz PSD reference Level

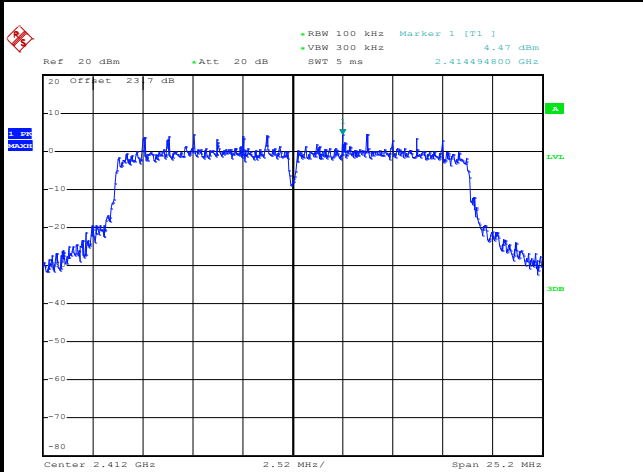

Date: 21.APR.2016 11:48:16

Low Channel Plot

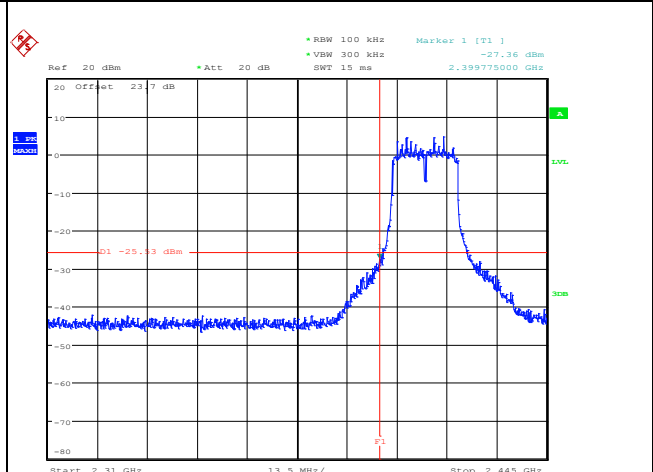

Date: 23.APR.2016 16:14:47

Spurious Emission 30MHz~3GHz

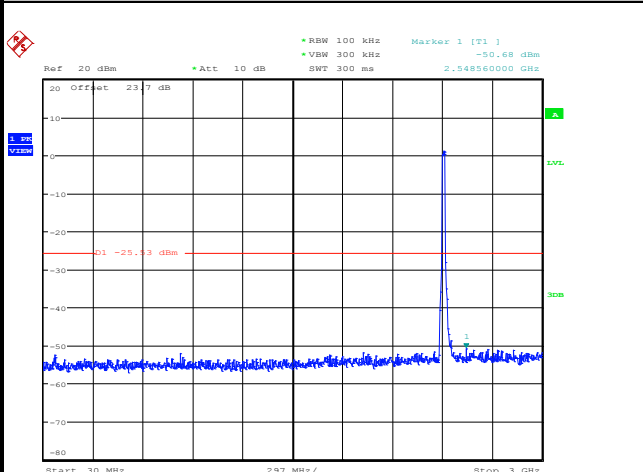

Date: 23.APR.2016 16:15:17

Spurious Emission 2GHz~25GHz

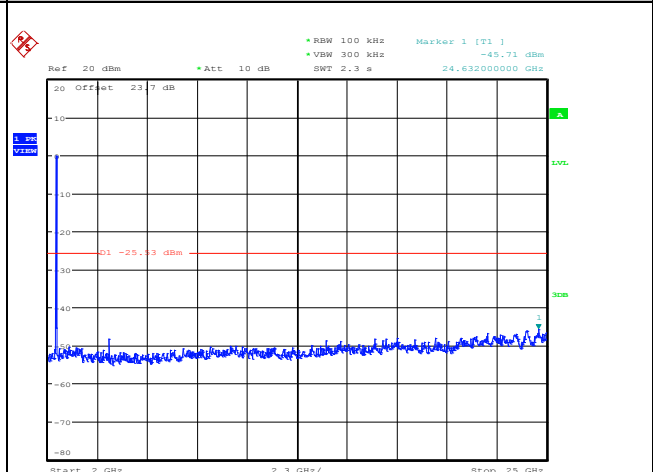

Date: 23.APR.2016 16:15:25



Number of TX :	2	Ant. :	1
Test Mode :	802.11ac VHT20	Temperature :	21~25°C
Test Band :	2.4GHz Mid	Relative Humidity :	51~54%
Test Channel :	06	Test Engineer :	Luffy Lin

WLAN 802.11ac VHT20 Channel 06

100kHz PSD reference Level

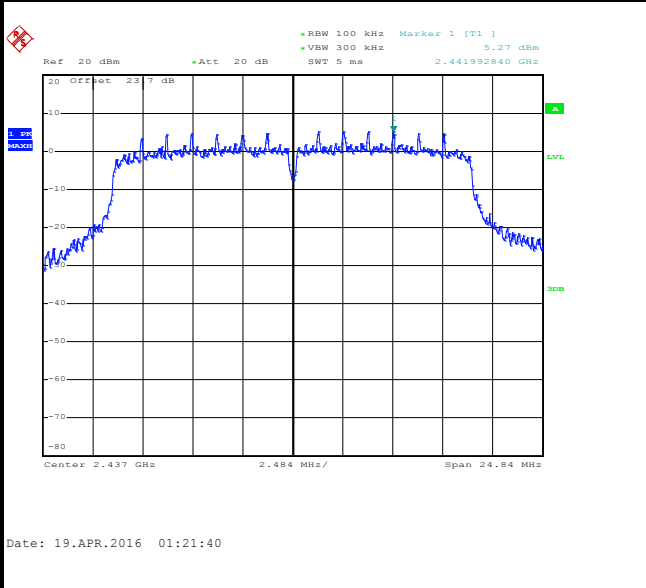

Spurious Emission 30MHz~3GHz

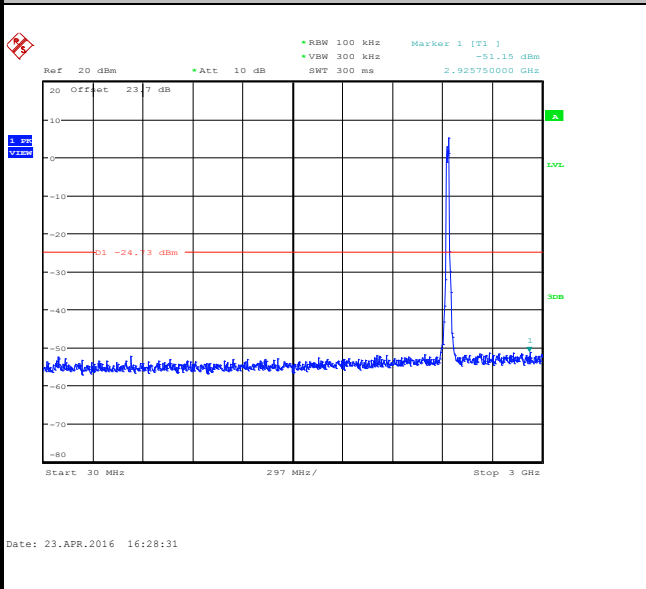

Spurious Emission 2GHz~25GHz

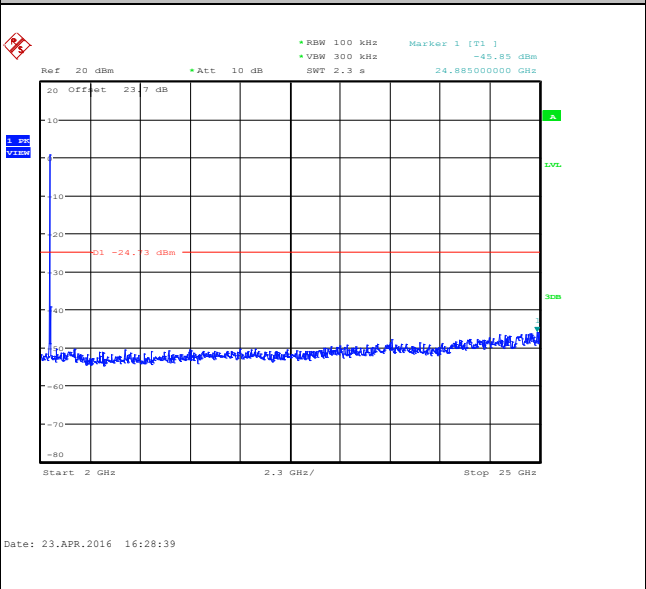



Number of TX :	2	Ant. :	1
Test Mode :	802.11ac VHT20	Temperature :	21~25°C
Test Band :	2.4GHz High	Relative Humidity :	51~54%
Test Channel :	11	Test Engineer :	Luffy Lin

WLAN 802.11ac VHT20 Channel 11

100kHz PSD reference Level



High Channel Plot

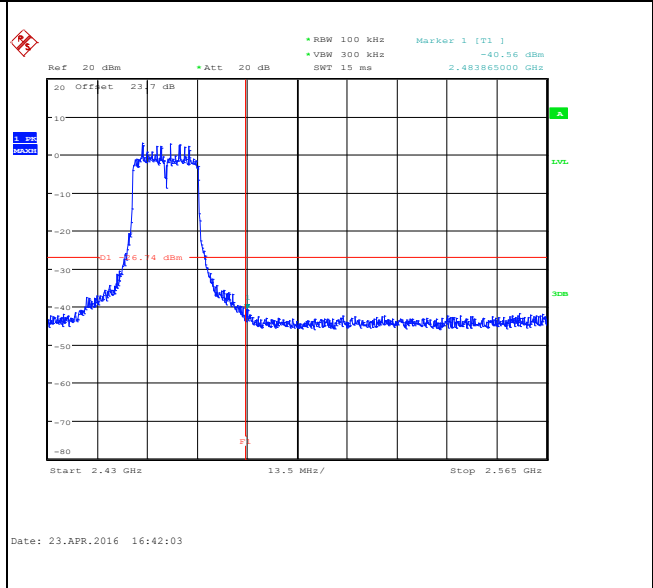

Spurious Emission 30MHz~3GHz

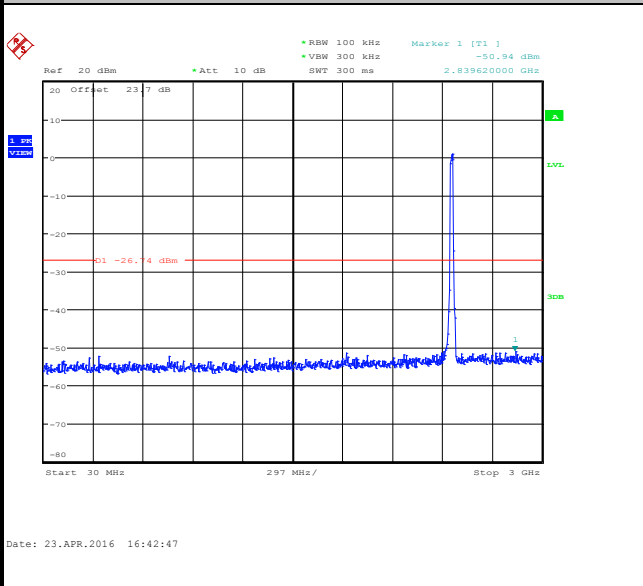

Spurious Emission 2GHz~25GHz

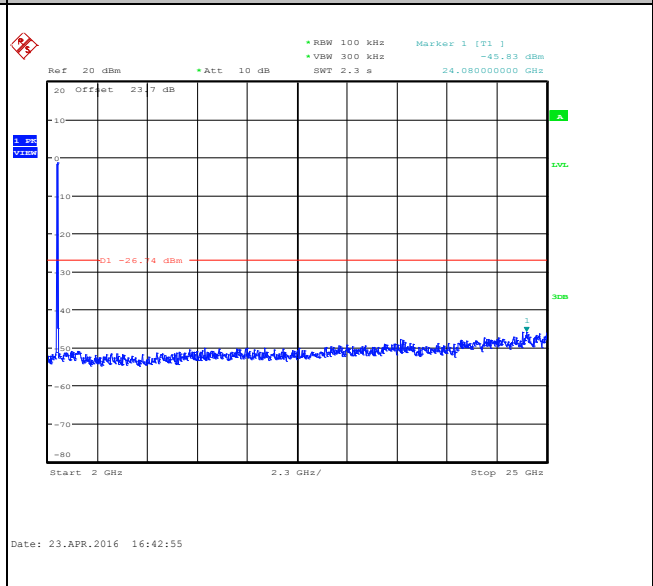



Number of TX = 2, Ant. 2 (Measured)

Number of TX :	2	Ant. :	2
Test Mode :	802.11b	Temperature :	21~25°C
Test Band :	2.4GHz Low	Relative Humidity :	51~54%
Test Channel :	01	Test Engineer :	Luffy Lin

WLAN 802.11b Channel 01

100kHz PSD reference Level

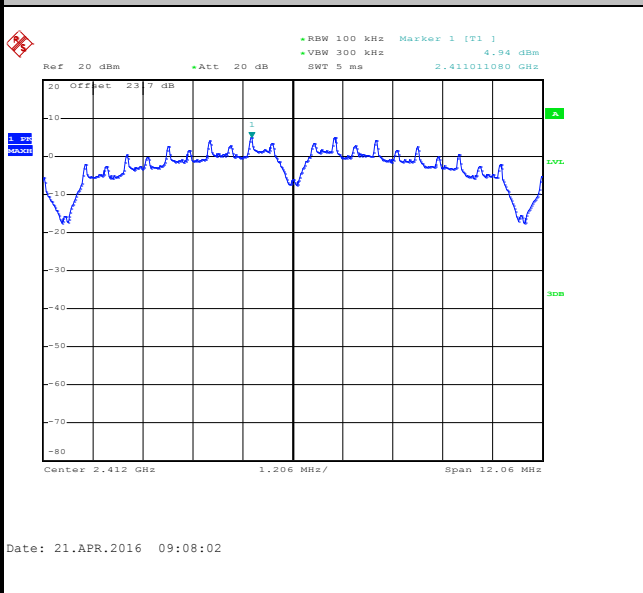

Low Channel Plot

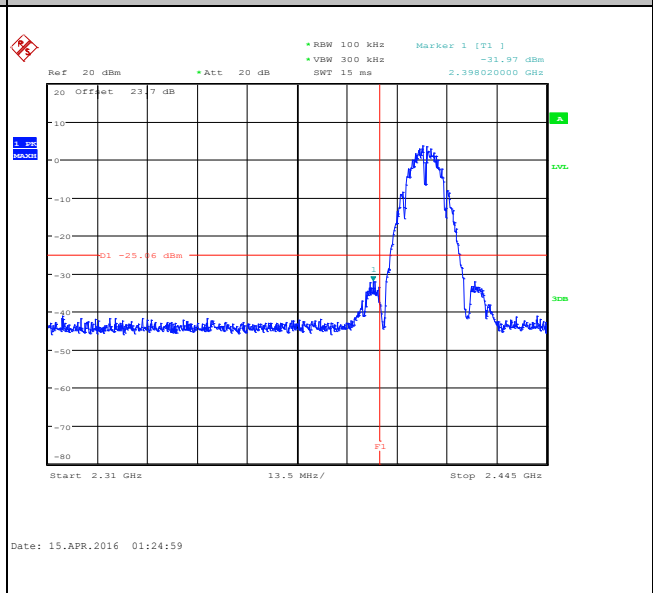

Spurious Emission 30MHz~3GHz

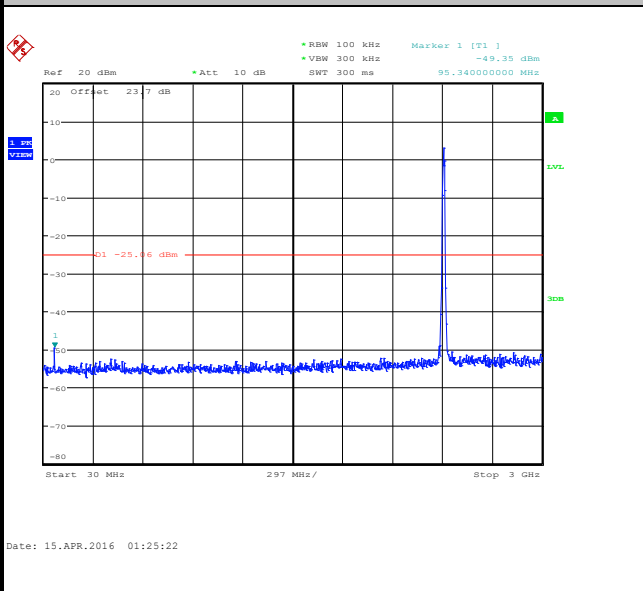

Spurious Emission 2GHz~25GHz

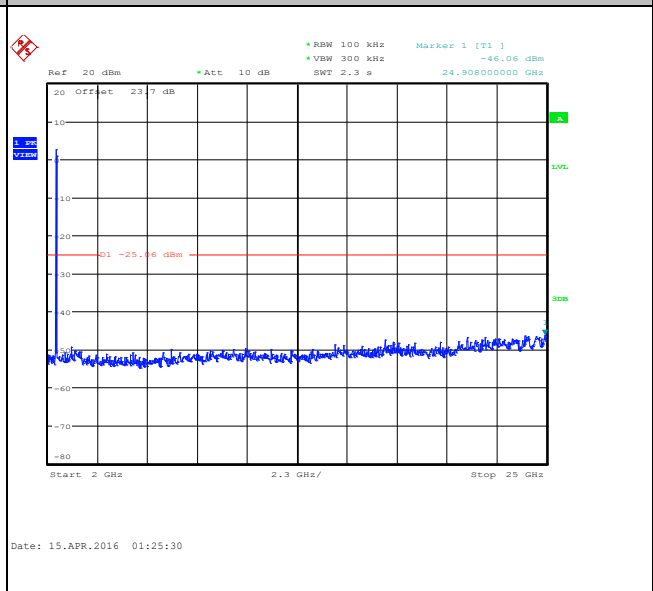



Number of TX :	2	Ant. :	2
Test Mode :	802.11b	Temperature :	21~25°C
Test Band :	2.4GHz Mid	Relative Humidity :	51~54%
Test Channel :	06	Test Engineer :	Luffy Lin

WLAN 802.11b Channel 06

100kHz PSD reference Level

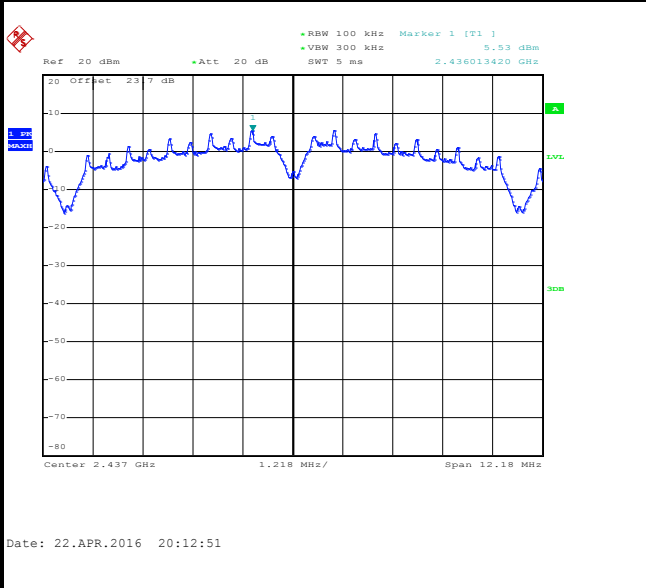

Spurious Emission 30MHz~3GHz

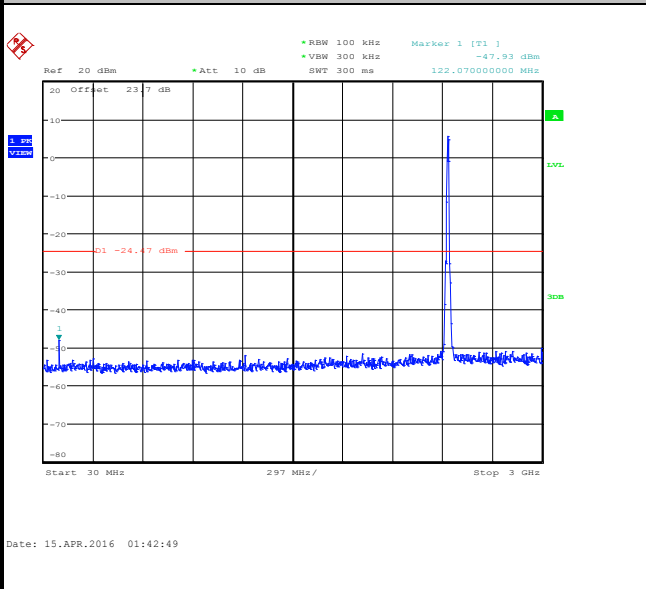

Spurious Emission 2GHz~25GHz

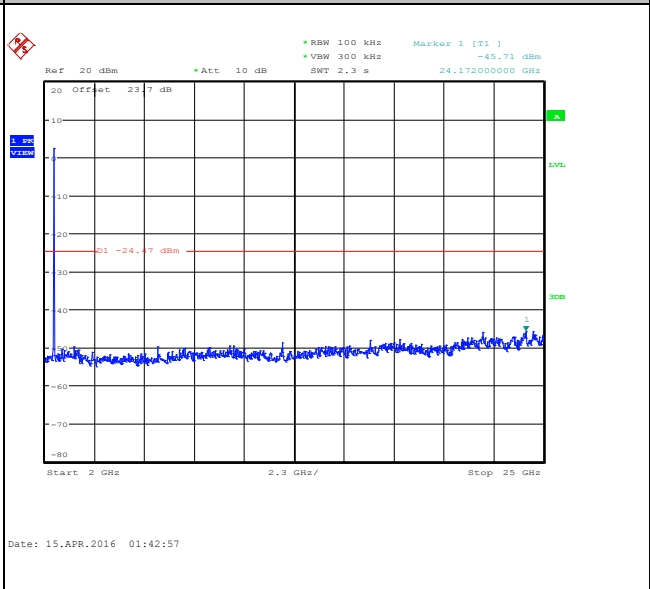



Number of TX :	2	Ant. :	2
Test Mode :	802.11b	Temperature :	21~25°C
Test Band :	2.4GHz High	Relative Humidity :	51~54%
Test Channel :	11	Test Engineer :	Luffy Lin

WLAN 802.11b Channel 11

100kHz PSD reference Level

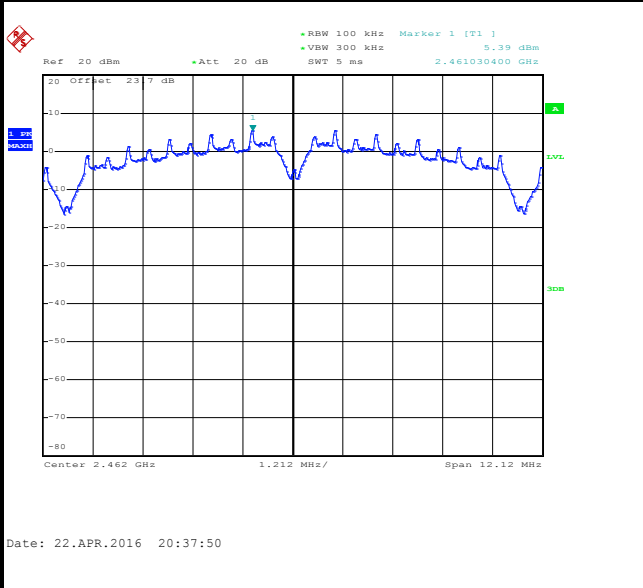

High Channel Plot

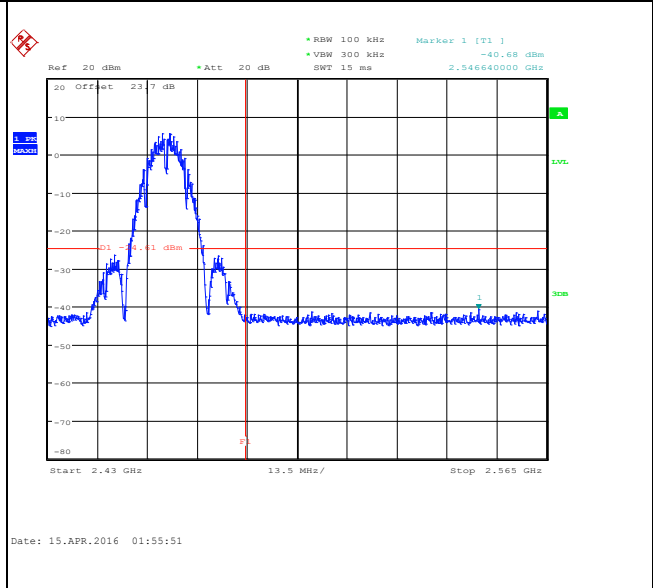

Spurious Emission 30MHz~3GHz

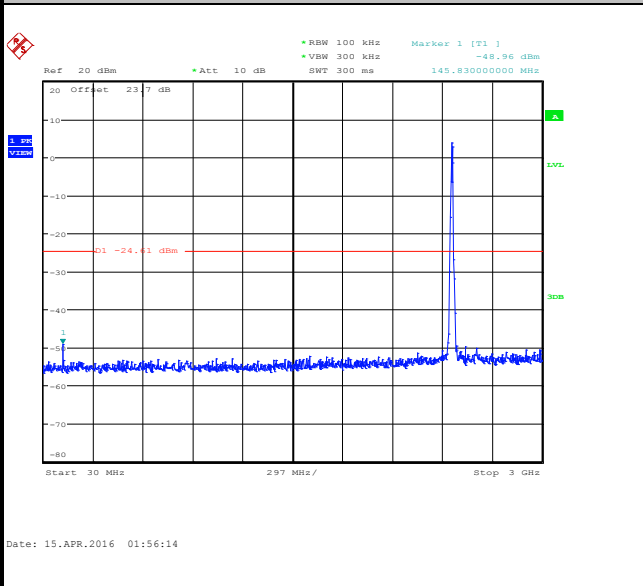

Spurious Emission 2GHz~25GHz

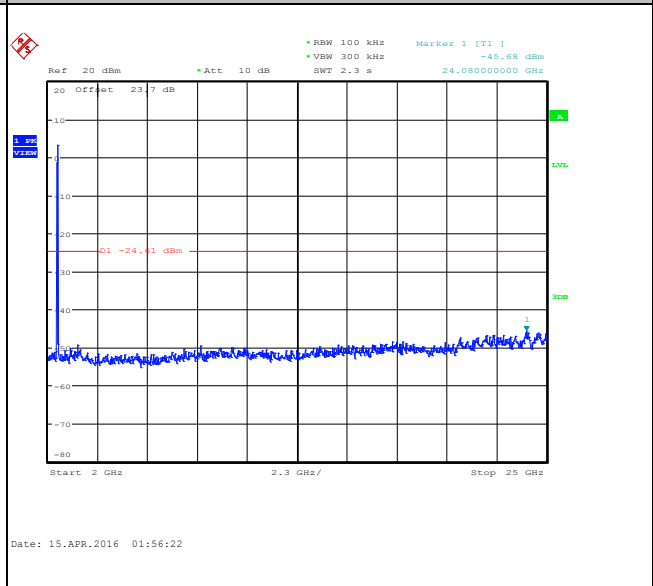



Number of TX :	2	Ant. :	2
Test Mode :	802.11g	Temperature :	21~25°C
Test Band :	2.4GHz Low	Relative Humidity :	51~54%
Test Channel :	01	Test Engineer :	Luffy Lin

WLAN 802.11g Channel 01

100kHz PSD reference Level

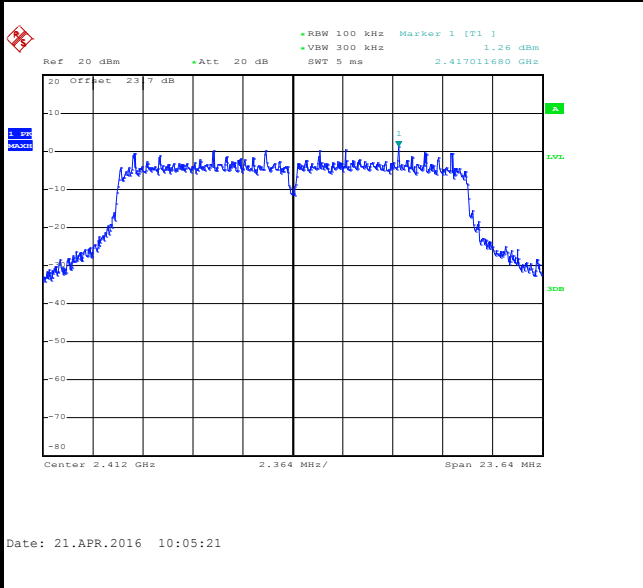

Low Channel Plot

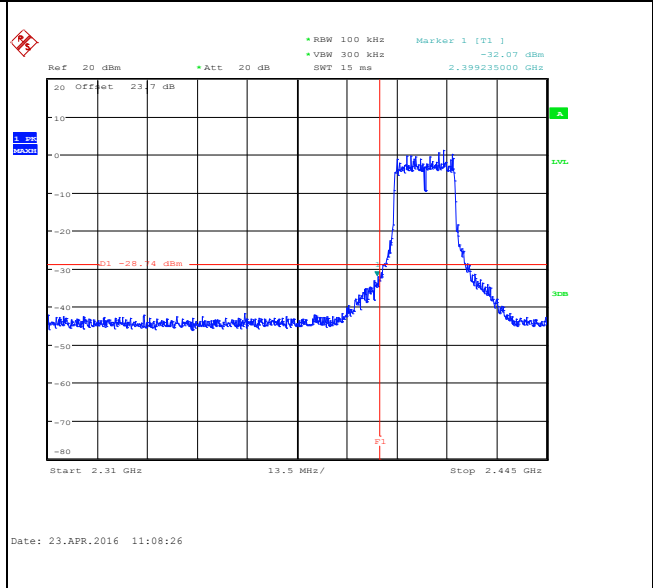

Spurious Emission 30MHz~3GHz

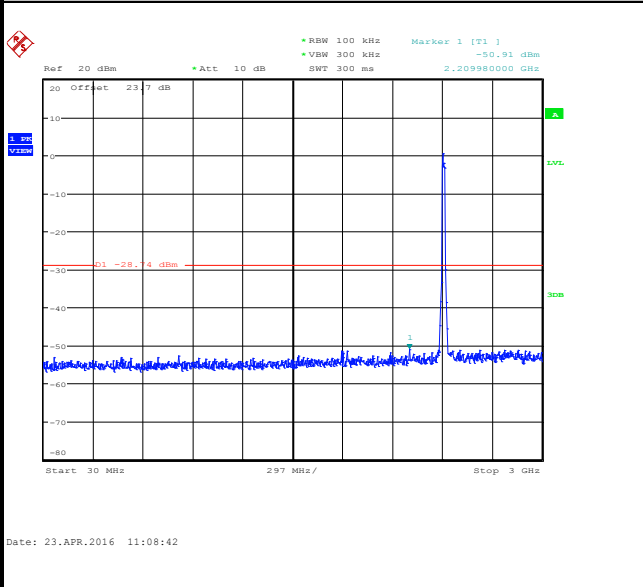

Spurious Emission 2GHz~25GHz

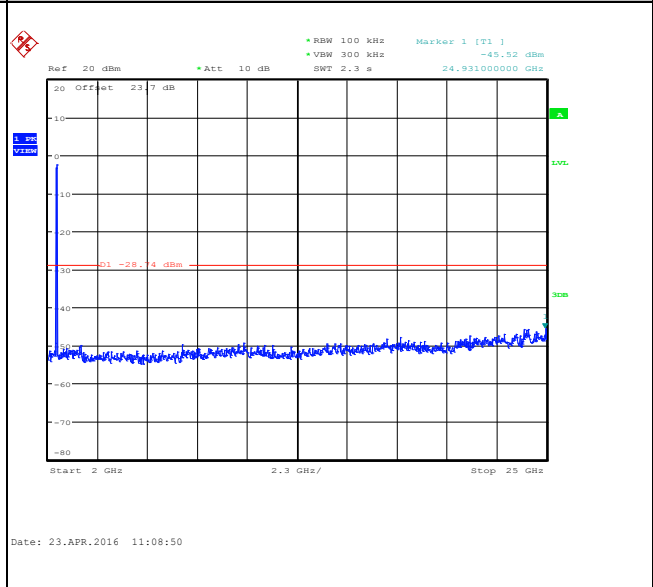



Number of TX :	2	Ant. :	2
Test Mode :	802.11g	Temperature :	21~25°C
Test Band :	2.4GHz Mid	Relative Humidity :	51~54%
Test Channel :	06	Test Engineer :	Luffy Lin

WLAN 802.11g Channel 06

100kHz PSD reference Level

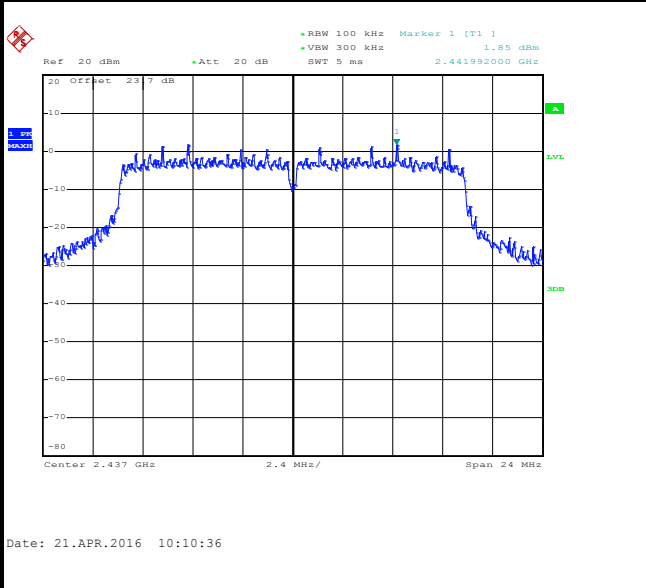

Spurious Emission 30MHz~3GHz

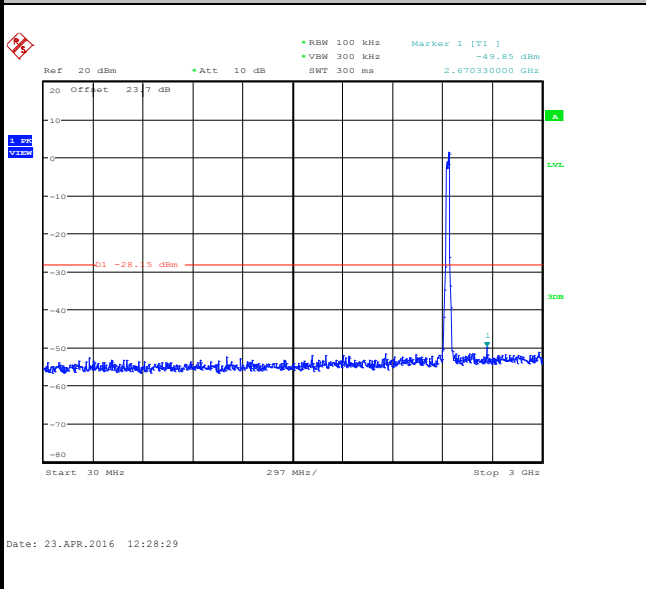

Spurious Emission 2GHz~25GHz

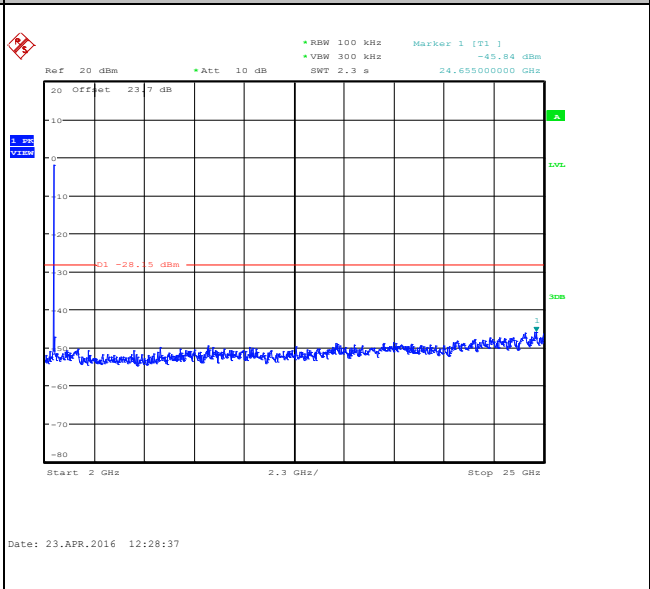



Number of TX :	2	Ant. :	2
Test Mode :	802.11g	Temperature :	21~25°C
Test Band :	2.4GHz High	Relative Humidity :	51~54%
Test Channel :	11	Test Engineer :	Luffy Lin

WLAN 802.11g Channel 11

100kHz PSD reference Level

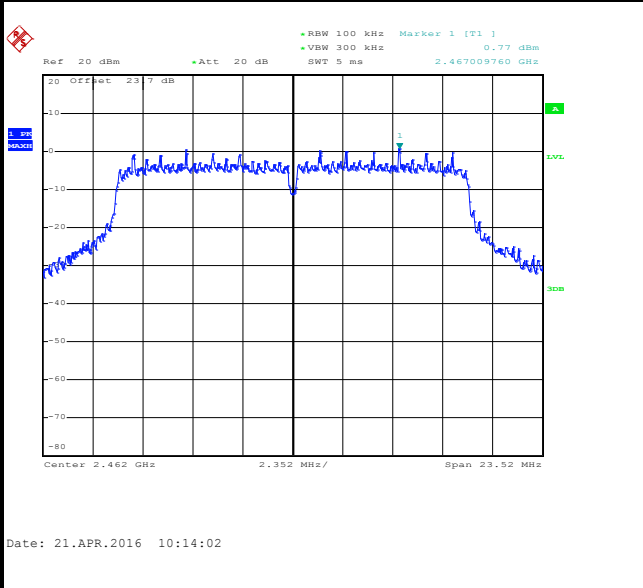

High Channel Plot

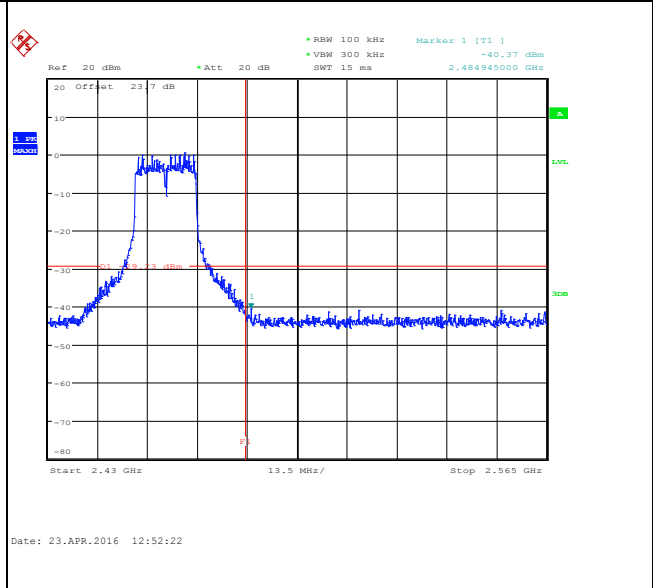

Spurious Emission 30MHz~3GHz

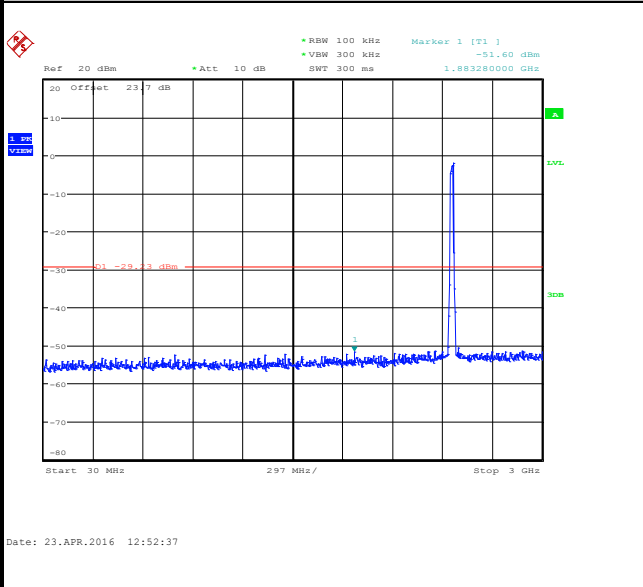

Spurious Emission 2GHz~25GHz

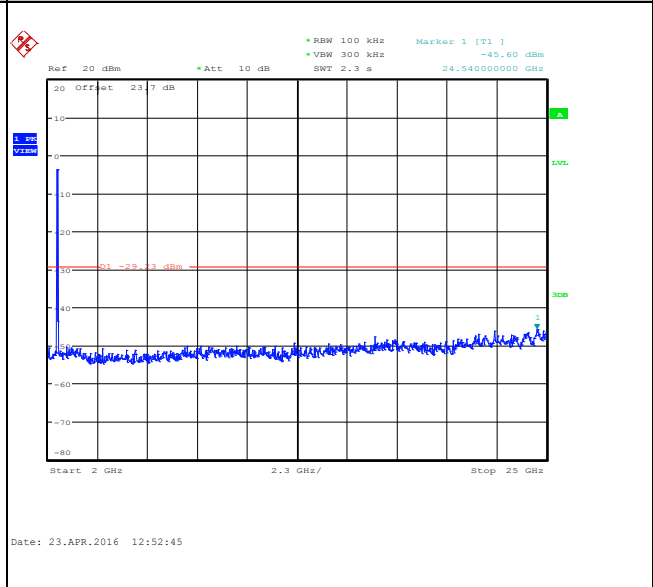



Number of TX :	2	Ant. :	2
Test Mode :	802.11n HT20	Temperature :	21~25°C
Test Band :	2.4GHz Low	Relative Humidity :	51~54%
Test Channel :	01	Test Engineer :	Luffy Lin

WLAN 802.11n HT20 Channel 01

100kHz PSD reference Level

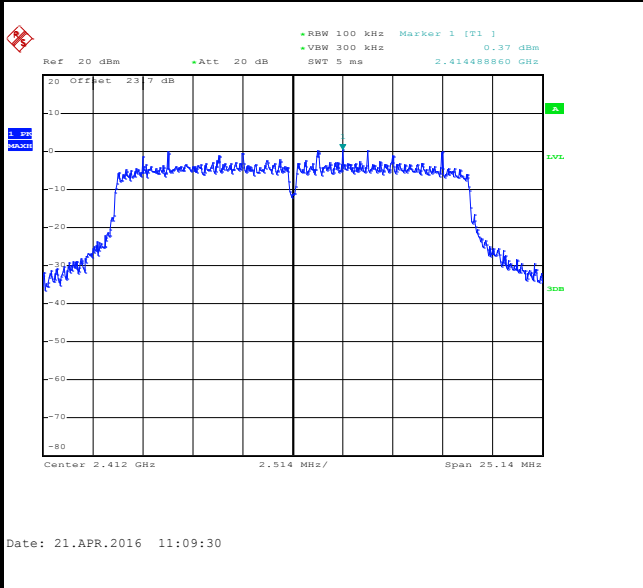

Low Channel Plot

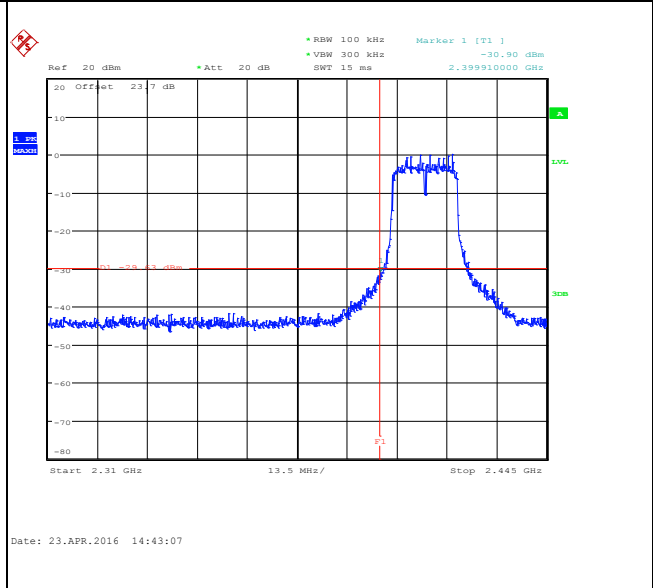

Spurious Emission 30MHz~3GHz

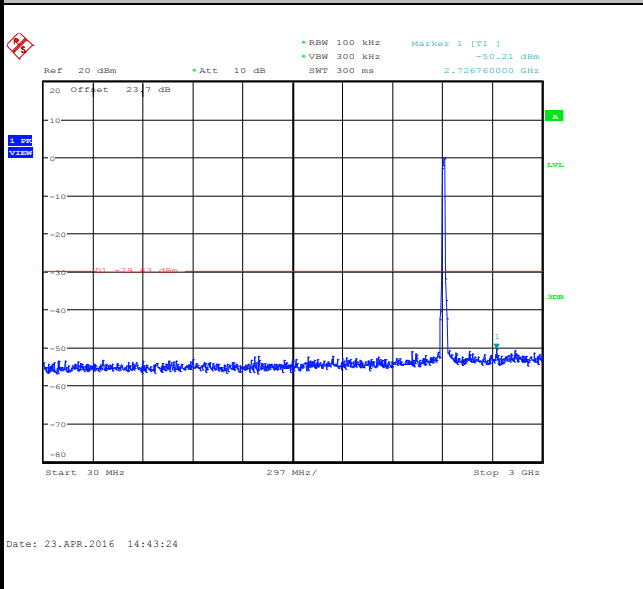

Spurious Emission 2GHz~25GHz

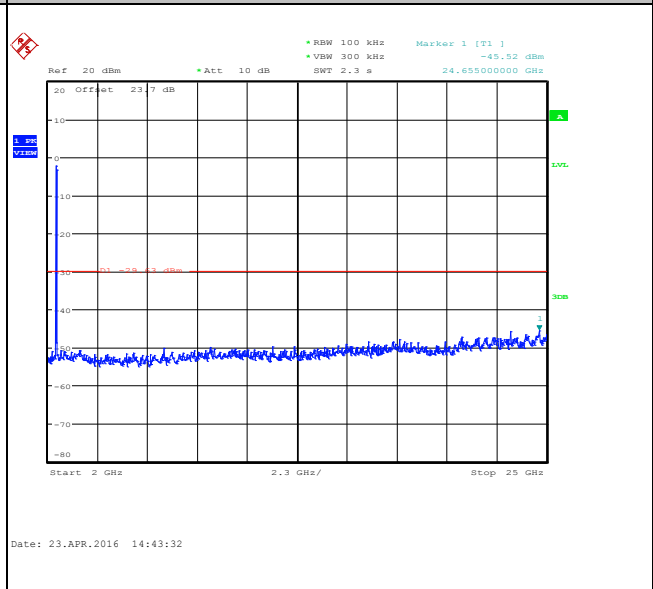



Number of TX :	2	Ant. :	2
Test Mode :	802.11n HT20	Temperature :	21~25°C
Test Band :	2.4GHz Mid	Relative Humidity :	51~54%
Test Channel :	06	Test Engineer :	Luffy Lin

WLAN 802.11n HT20 Channel 06

100kHz PSD reference Level

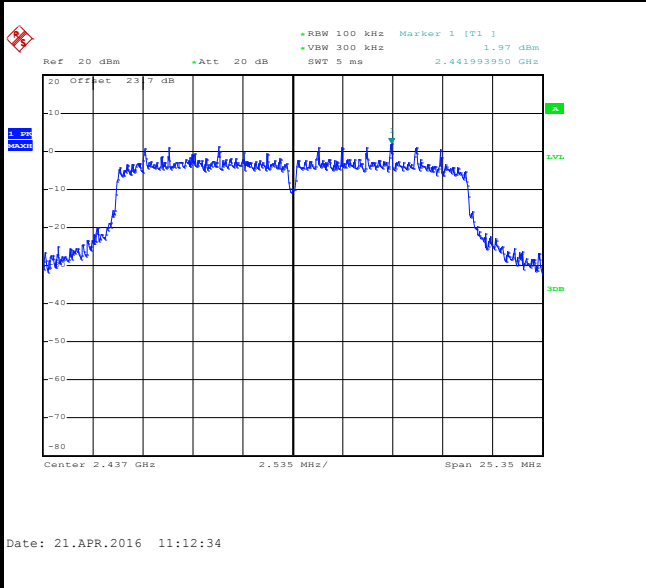

Spurious Emission 30MHz~3GHz

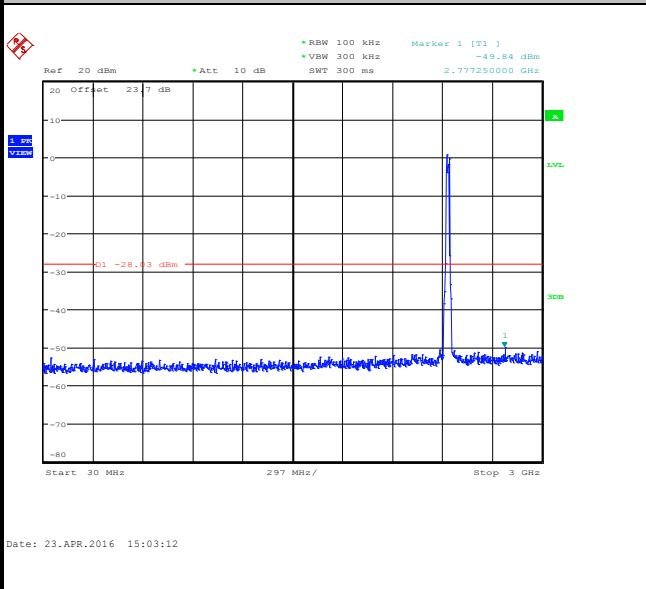

Spurious Emission 2GHz~25GHz

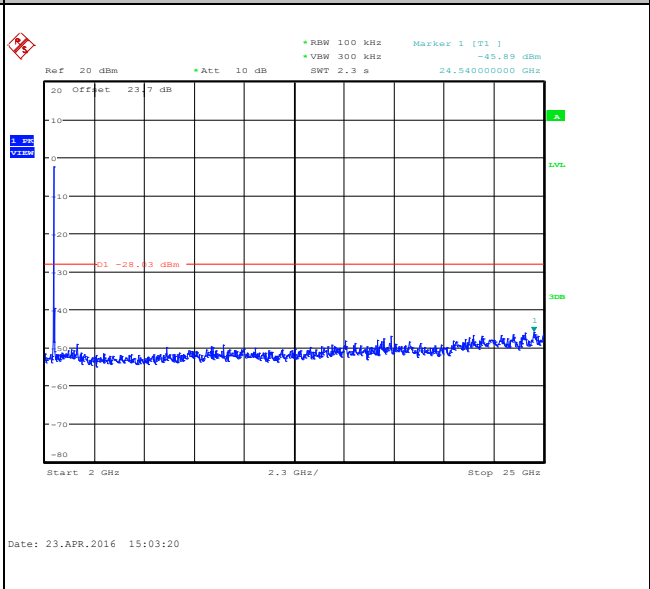



Number of TX :	2	Ant. :	2
Test Mode :	802.11n HT20	Temperature :	21~25°C
Test Band :	2.4GHz High	Relative Humidity :	51~54%
Test Channel :	11	Test Engineer :	Luffy Lin

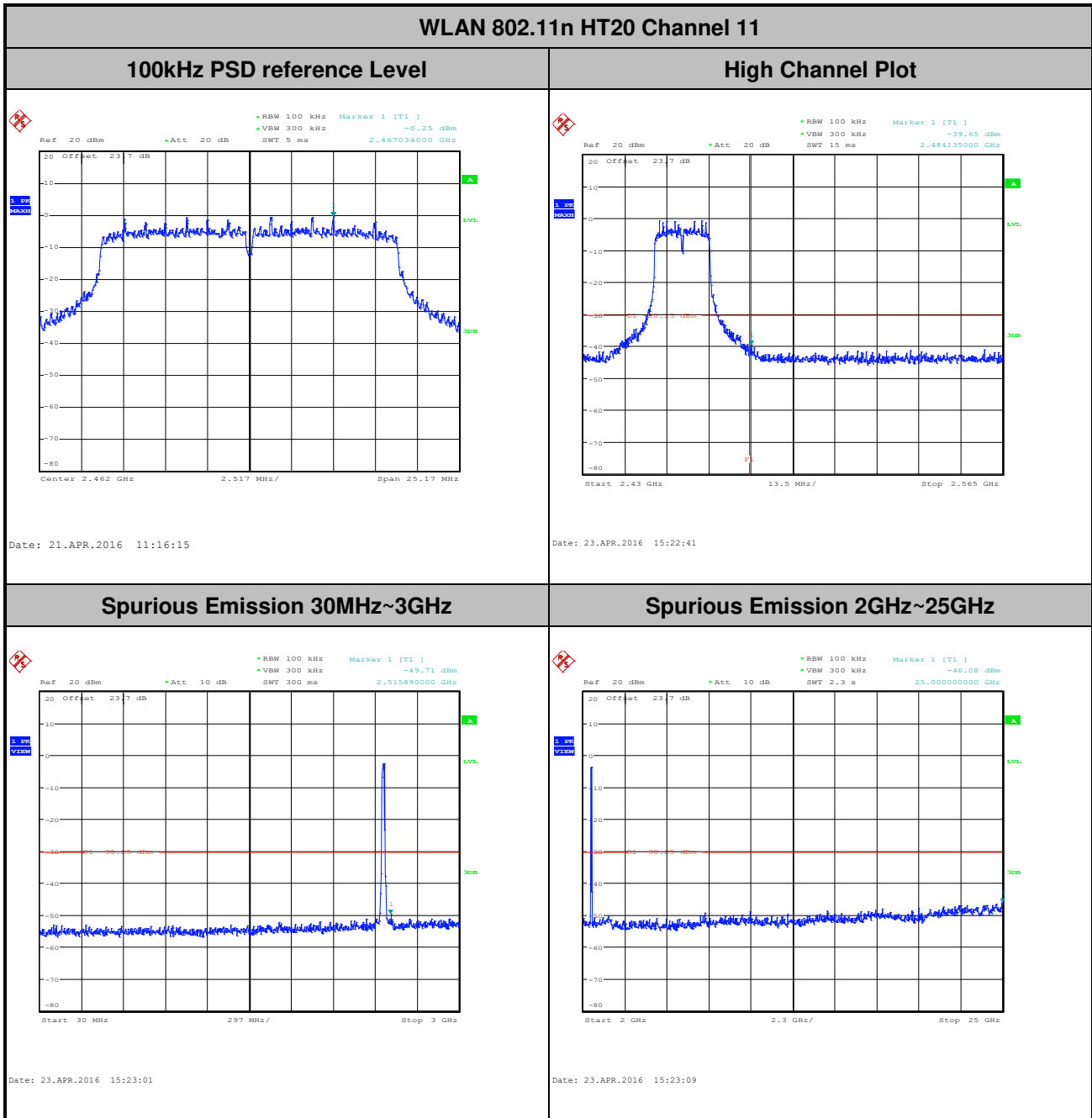



Number of TX :	2	Ant. :	2
Test Mode :	802.11ac VHT20	Temperature :	21~25°C
Test Band :	2.4GHz Low	Relative Humidity :	51~54%
Test Channel :	01	Test Engineer :	Luffy Lin

WLAN 802.11ac VHT20 Channel 01

100kHz PSD reference Level

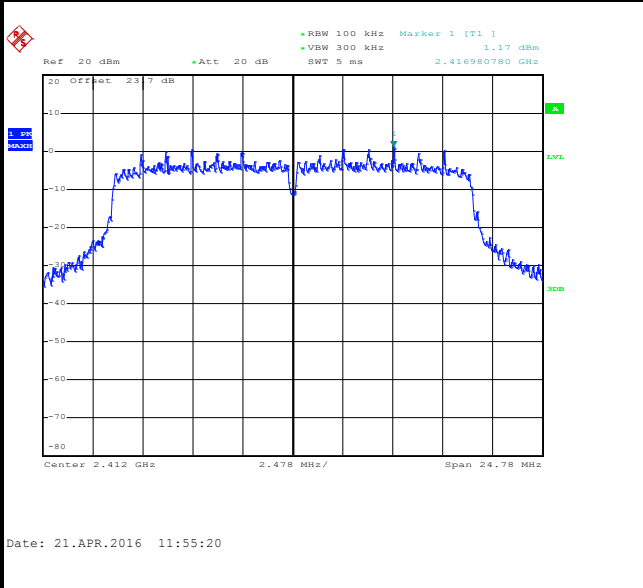

Low Channel Plot

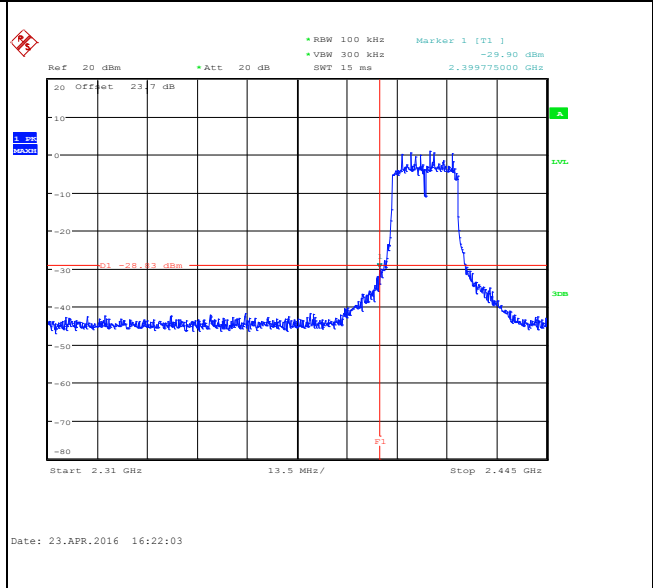

Spurious Emission 30MHz~3GHz

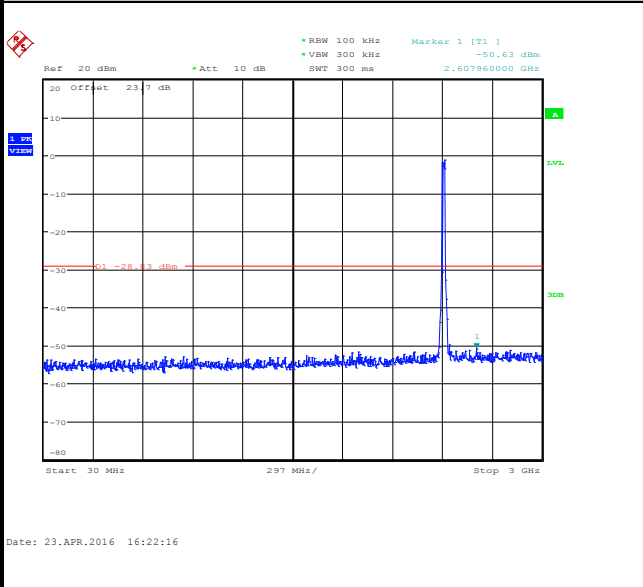

Spurious Emission 2GHz~25GHz

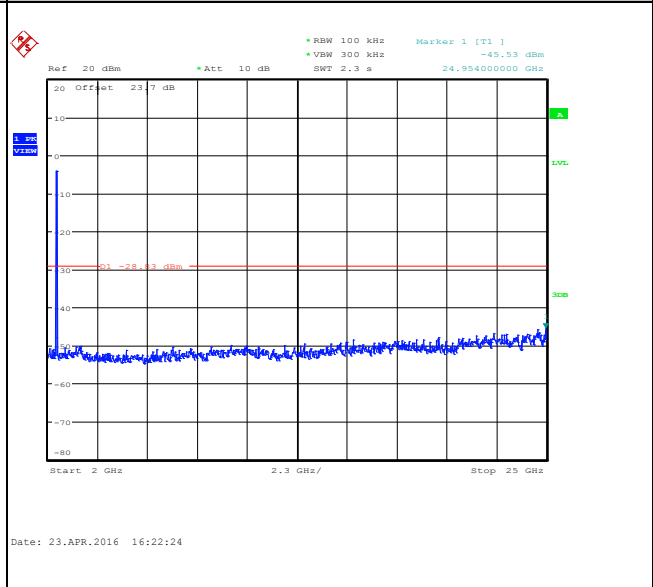



Number of TX :	2	Ant. :	2
Test Mode :	802.11ac VHT20	Temperature :	21~25°C
Test Band :	2.4GHz Mid	Relative Humidity :	51~54%
Test Channel :	06	Test Engineer :	Luffy Lin

WLAN 802.11ac VHT20 Channel 06

100kHz PSD reference Level

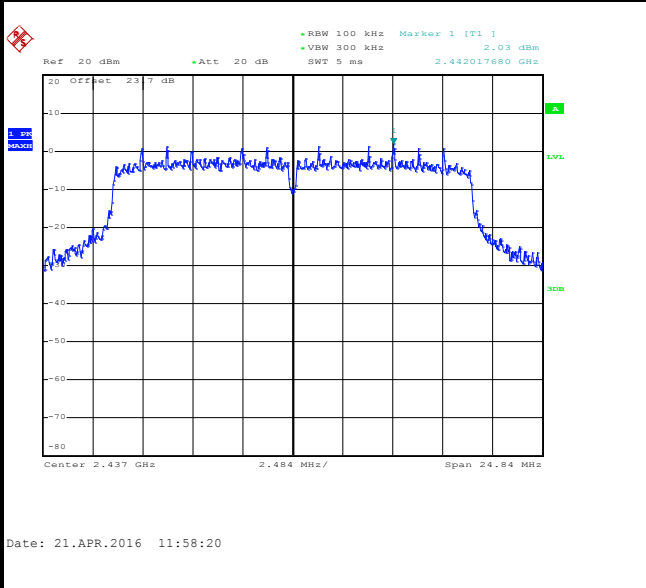

Spurious Emission 30MHz~3GHz

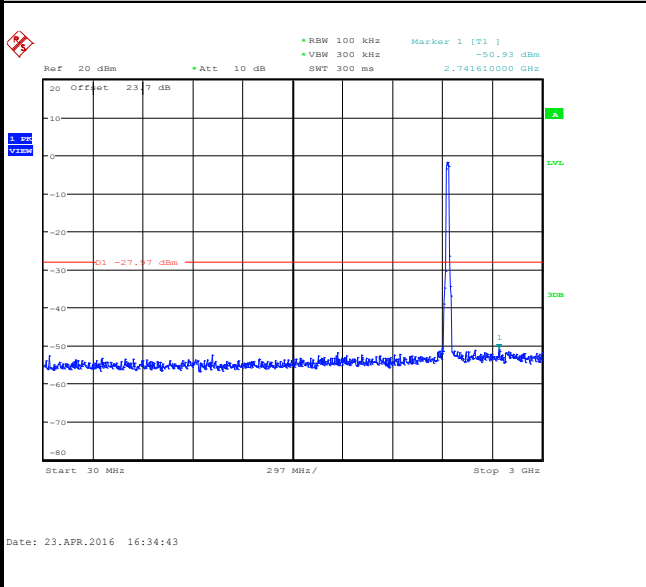

Spurious Emission 2GHz~25GHz

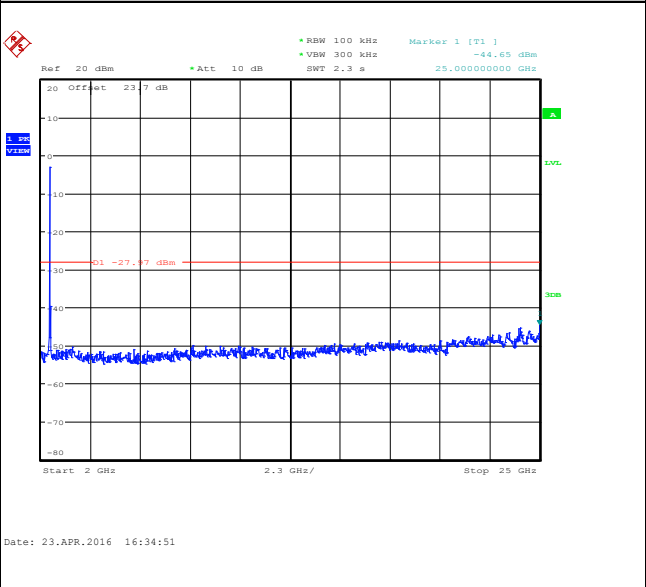



Number of TX :	2	Ant. :	2
Test Mode :	802.11ac VHT20	Temperature :	21~25°C
Test Band :	2.4GHz High	Relative Humidity :	51~54%
Test Channel :	11	Test Engineer :	Luffy Lin

WLAN 802.11ac VHT20 Channel 11

100kHz PSD reference Level

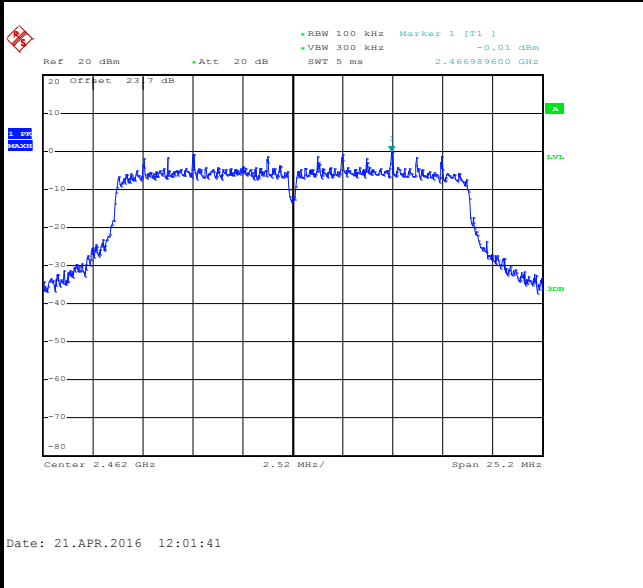

High Channel Plot

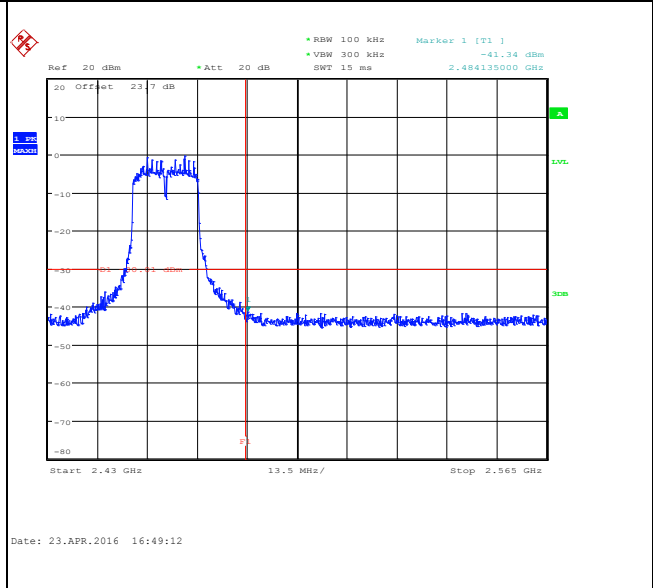

Spurious Emission 30MHz~3GHz

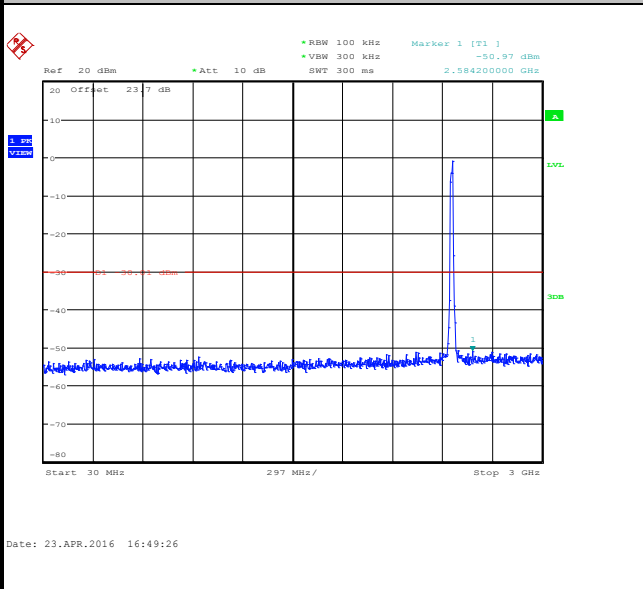

Spurious Emission 2GHz~25GHz

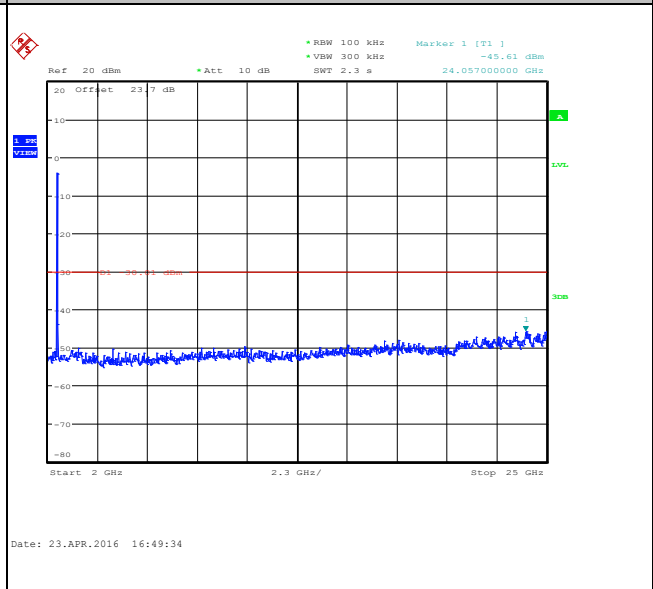



3.5 Radiated Band Edges and Spurious Emission Measurement

3.5.1 Limit of Radiated band edge and Spurious Emission Measurement

In any 100 kHz bandwidth outside the intentional radiator frequency band, all harmonics/spurious must be at least 20 dB below the highest emission level within the authorized band. If the output power of this device was measured by spectrum analyzer, the attenuation under this paragraph shall be 30 dB instead of 20 dB. In addition, radiated emissions which fall in the restricted bands must also comply with the FCC section 15.209 limits as below.

Frequency (MHz)	Field Strength (microvolts/meter)	Measurement Distance (meters)
0.009 – 0.490	2400/F(kHz)	300
0.490 – 1.705	24000/F(kHz)	30
1.705 – 30.0	30	30
30 – 88	100	3
88 – 216	150	3
216 - 960	200	3
Above 960	500	3

3.5.2 Measuring Instruments

The measuring equipment is listed in the section 4 of this test report.



3.5.3 Test Procedure

1. The testing follows ANSI C63.10-2013.
2. The EUT was arranged to its worst case and then tune the antenna tower (from 1 m to 4 m) and turntable (from 0 degree to 360 degrees) to find the maximum reading. A pre-amp and a high pass filter are used for the test in order to get better signal level.
3. The EUT was placed on a turntable with 0.8 meter for frequency below 1GHz and 1.5 meter for frequency above 1GHz respectively above ground.
4. The EUT was set 3 meters from the interference receiving antenna, which was mounted on the top of a variable height antenna tower.
5. Corrected Reading: Antenna Factor + Cable Loss + Read Level - Preamp Factor = Level
6. For measurement below 1GHz, If the emission level of the EUT measured by the peak detector is 3 dB lower than the applicable limit, the peak emission level will be reported. Otherwise, the emission measurement will be repeated using the quasi-peak detector and reported.
7. Use the following spectrum analyzer settings:
 - (1) Span shall wide enough to fully capture the emission being measured;
 - (2) Set RBW=100 kHz for $f < 1$ GHz; VBW \geq RBW; Sweep = auto; Detector function = peak; Trace = max hold;
 - (3) Set RBW = 1 MHz, VBW= 3MHz for $f \geq 1$ GHz for peak measurement.
For average measurement:
 - VBW = 10 Hz, when duty cycle is no less than 98 percent.
 - VBW $\geq 1/T$, when duty cycle is less than 98 percent where T is the minimum transmission duration over which the transmitter is on and is transmitting at its maximum power control level for the tested mode of operation.

3.5.4 Test Setup

For radiated emissions below 30MHz

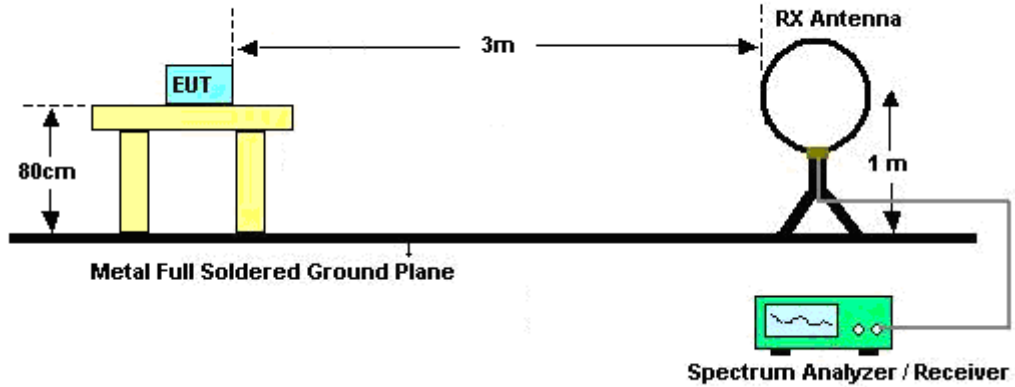

For radiated emissions from 30MHz to 1GHz

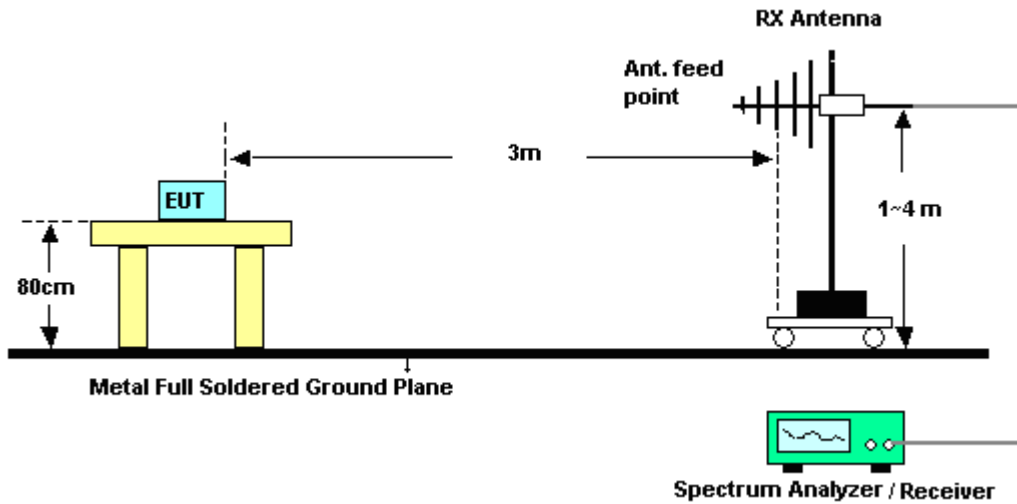

For radiated emissions above 1GHz

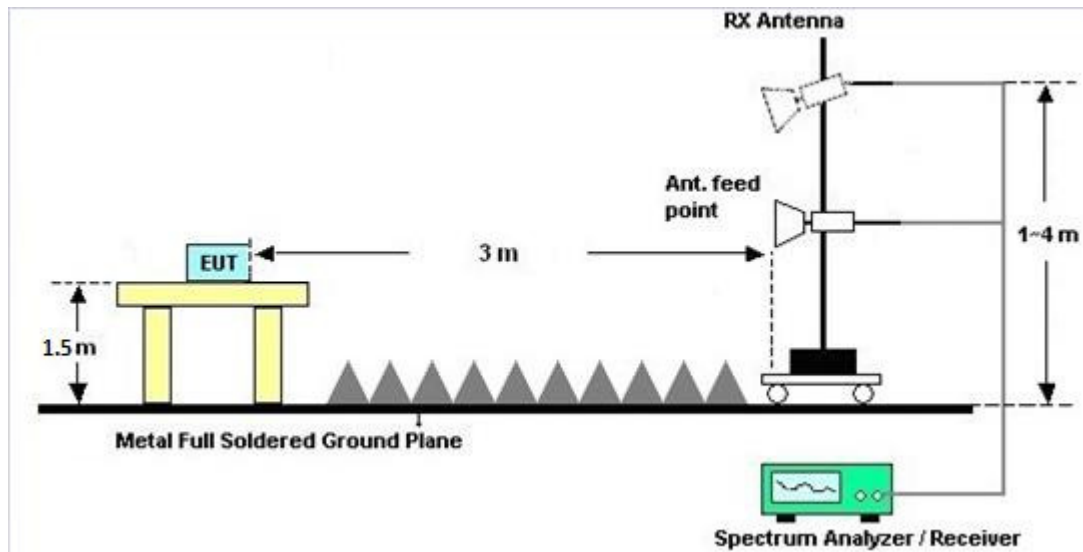

3.5.5 Test Results of Radiated Emissions (9kHz ~ 30MHz)

The low frequency, which started from 9 kHz to 30MHz, was pre-scanned and the result which was 20dB lower than the limit line per 15.31(o) was not reported.

3.5.6 Test Result of Radiated Spurious at Band Edges

Please refer to Appendix B and C.

3.5.7 Duty Cycle

Please refer to Appendix D.

3.5.8 Test Result of Radiated Spurious Emission (30MHz ~ 10th Harmonic)

Please refer to Appendix B and C.



3.6 AC Conducted Emission Measurement

3.6.1 Limit of AC Conducted Emission

For equipment that is designed to be connected to the public utility (AC) power line, the radio frequency voltage that is conducted back onto the AC power line on any frequency or frequencies within the band 150 kHz to 30 MHz shall not exceed the limits in the following table.

Frequency of Emission (MHz)	Conducted Limit (dBµV)	
	Quasi-Peak	Average
0.15-0.5	66 to 56*	56 to 46*
0.5-5	56	46
5-30	60	50

*Decreases with the logarithm of the frequency.

3.6.2 Measuring Instruments

The measuring equipment is listed in the section 4 of this test report.

3.6.3 Test Procedures

1. The EUT was placed 0.4 meter from the conducting wall of the shielding room, and it was kept at least 80 centimeters from any other grounded conducting surface.
2. Connect EUT to the power mains through a line impedance stabilization network (LISN).
3. All the support units are connecting to the other LISN.
4. The LISN provides 50 ohm coupling impedance for the measuring instrument.
5. The FCC states that a 50 ohm, 50 microhenry LISN should be used.
6. Both sides of AC line were checked for maximum conducted interference.
7. The frequency range from 150 kHz to 30 MHz was searched.
8. Set the test-receiver system to Peak Detect Function and specified bandwidth (IF bandwidth = 9kHz) with Maximum Hold Mode.

3.6.4 Test Setup

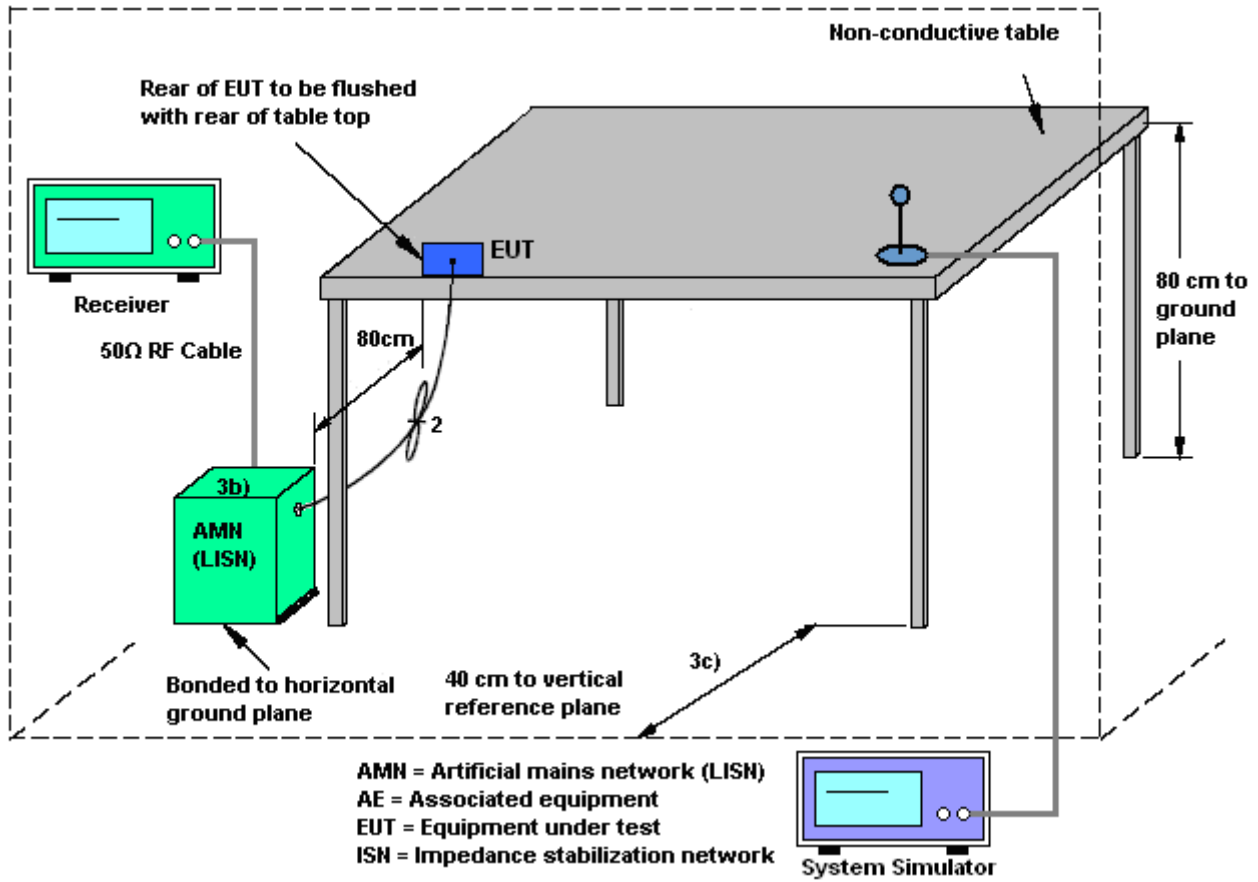



3.6.5 Test Result of AC Conducted Emission

Test Mode :	Mode 1	Temperature :	21~22°C
Test Engineer :	Derreck Chen	Relative Humidity :	47~48%
Test Voltage :	120Vac / 60Hz	Phase :	Line
Function Type :	GSM850 Idle + WLAN (2.4GHz) Link + Bluetooth Link + Adapter + MP3		

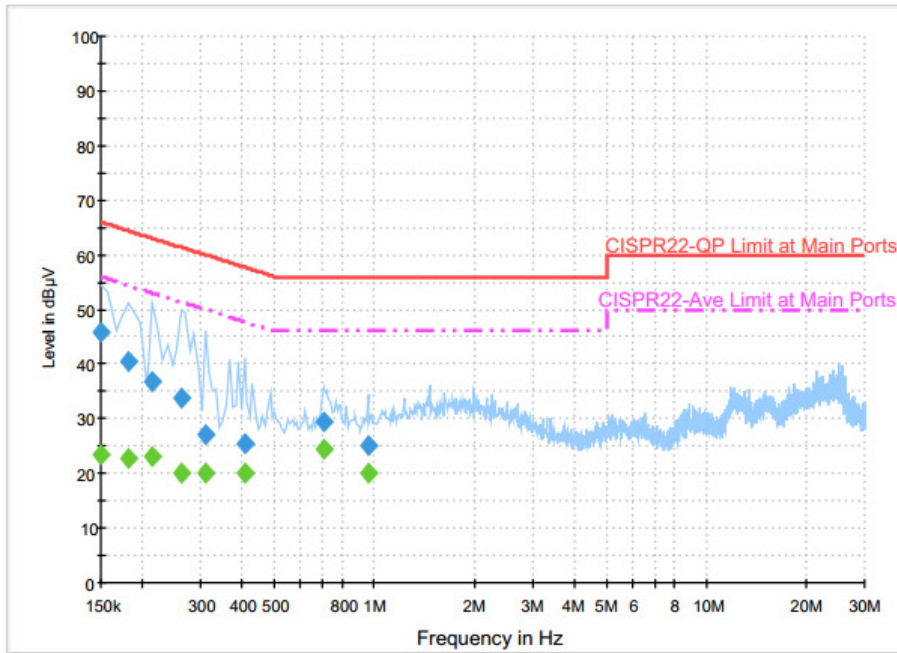

Final Result : QuasiPeak

Frequency (MHz)	QuasiPeak (dBµV)	Filter	Line	Corr. (dB)	Margin (dB)	Limit (dBµV)
0.150000	45.9	Off	L1	19.6	20.1	66.0
0.182000	40.3	Off	L1	19.6	24.1	64.4
0.214000	36.8	Off	L1	19.6	26.2	63.0
0.262000	33.9	Off	L1	19.6	27.5	61.4
0.310000	27.1	Off	L1	19.6	32.9	60.0
0.406000	25.4	Off	L1	19.6	32.3	57.7
0.702000	29.5	Off	L1	19.6	26.5	56.0
0.958000	25.2	Off	L1	19.6	30.8	56.0

Final Result : Average

Frequency (MHz)	Average (dBµV)	Filter	Line	Corr. (dB)	Margin (dB)	Limit (dBµV)
0.150000	23.3	Off	L1	19.6	32.7	56.0
0.182000	22.7	Off	L1	19.6	31.7	54.4
0.214000	23.0	Off	L1	19.6	30.0	53.0
0.262000	20.1	Off	L1	19.6	31.3	51.4
0.310000	19.9	Off	L1	19.6	30.1	50.0
0.406000	20.2	Off	L1	19.6	27.5	47.7
0.702000	24.3	Off	L1	19.6	21.7	46.0
0.958000	19.9	Off	L1	19.6	26.1	46.0



Test Mode :	Mode 1	Temperature :	21~22°C
Test Engineer :	Derreck Chen	Relative Humidity :	47~48%
Test Voltage :	120Vac / 60Hz	Phase :	Neutral
Function Type :	GSM850 Idle + WLAN (2.4GHz) Link + Bluetooth Link + Adapter + MP3		

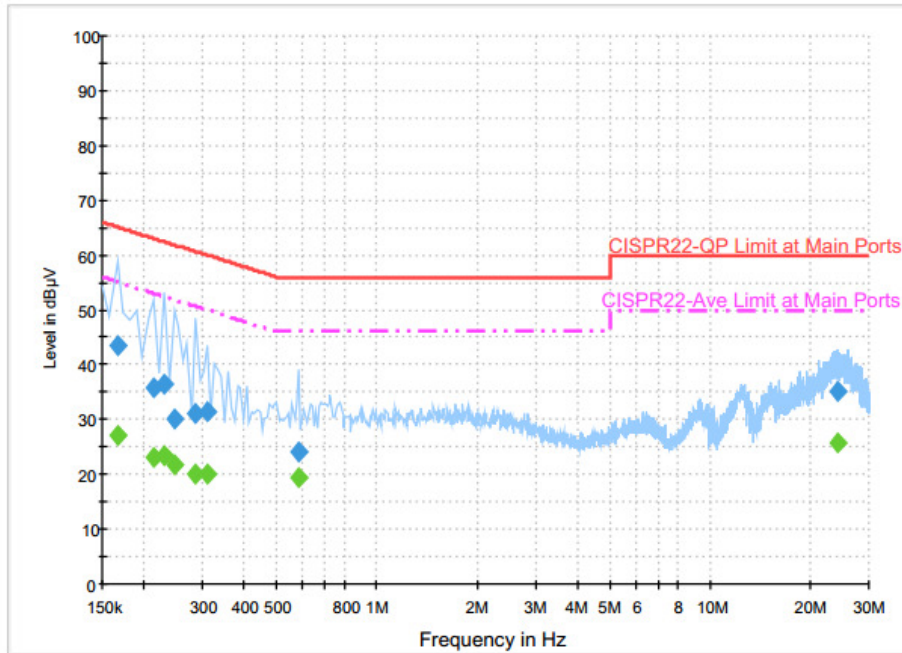

Final Result : QuasiPeak

Frequency (MHz)	QuasiPeak (dBµV)	Filter	Line	Corr. (dB)	Margin (dB)	Limit (dBµV)
0.166000	43.6	Off	N	19.6	21.6	65.2
0.214000	36.0	Off	N	19.6	27.0	63.0
0.230000	36.6	Off	N	19.6	25.8	62.4
0.246000	30.2	Off	N	19.6	31.7	61.9
0.286000	31.0	Off	N	19.6	29.6	60.6
0.310000	31.3	Off	N	19.6	28.7	60.0
0.582000	24.0	Off	N	19.6	32.0	56.0
24.286000	35.0	Off	N	20.0	25.0	60.0

Final Result : Average

Frequency (MHz)	Average (dBµV)	Filter	Line	Corr. (dB)	Margin (dB)	Limit (dBµV)
0.166000	26.9	Off	N	19.6	28.3	55.2
0.214000	23.1	Off	N	19.6	29.9	53.0
0.230000	23.5	Off	N	19.6	28.9	52.4
0.246000	21.7	Off	N	19.6	30.2	51.9
0.286000	20.1	Off	N	19.6	30.5	50.6
0.310000	19.9	Off	N	19.6	30.1	50.0
0.582000	19.5	Off	N	19.6	26.5	46.0
24.286000	25.7	Off	N	20.0	24.3	50.0



3.7 Antenna Requirements

3.7.1 Standard Applicable

If directional gain of transmitting Antennas is greater than 6dBi, the power shall be reduced by the same level in dB comparing to gain minus 6dBi. For the fixed point-to-point operation, the power shall be reduced by one dB for every 3 dB that the directional gain of the Antenna exceeds 6 dBi. The use of a permanently attached Antenna or of an Antenna that uses a unique coupling to the intentional radiator shall be considered sufficient to comply with the FCC rule.

3.7.2 Antenna Anti-Replacement Construction

An embedded-in antenna design is used.

3.7.3 Antenna Gain

FCC KDB 662911 D01 Multiple Transmitter Output v02r01.

For CDD transmissions, directional gain is calculated as

Directional gain = $G_{ANT} + \text{Array Gain}$, where Array Gain is as follows.

For power spectral density (PSD) measurements on all devices,

Array Gain = $10 \log(N_{ANT}/N_{SS}=1)$ dB.

For power measurements on IEEE 802.11 devices,

Array Gain = 0 dB (i.e., no array gain) for $N_{ANT} \leq 4$.

Directional gain may be calculated by using the formulas applicable to equal gain antennas with G_{ANT} set equal to the gain of the antenna having the highest gain;

The EUT supports CDD mode.

The power and PSD limit should be modified if the directional gain of EUT is over 6 dBi,

The directional gain "DG" is calculated as following table.

			DG	DG	Power	PSD
			for	for	Limit	Limit
	Ant. 1	Ant. 2	Power	PSD	Reduction	Reduction
	(dBi)	(dBi)	(dBi)	(dBi)	(dB)	(dB)
2.4 GHz	-3.70	-1.50	-1.50	0.48	0.00	0.00

$Power\ Limit\ Reduction = DG(Power) - 6dBi, (min = 0)$

$PSD\ Limit\ Reduction = DG(PSD) - 6dBi, (min = 0)$



4 List of Measuring Equipment

Instrument	Manufacturer	Model No.	Serial No.	Characteristics	Calibration Date	Test Date	Due Date	Remark
Power Meter	Anritsu	ML2495A	1132003	300MHz~40GHz	Aug. 12, 2015	Apr. 01, 2016 ~ Apr. 25, 2016	Aug. 11, 2016	Conducted (TH05-HY)
Power Sensor	Anritsu	MA2411B	1126017	300MHz~40GHz	Aug. 12, 2015	Apr. 01, 2016 ~ Apr. 25, 2016	Aug. 11, 2016	Conducted (TH05-HY)
Spectrum Analyzer	Rohde & Schwarz	FSQ	200578/026	9kHz-40GHz	May 19, 2015	Apr. 01, 2016 ~ Apr. 25, 2016	May 18, 2016	Conducted (TH05-HY)
AC Power Source	ChainTek	APC-1000W	N/A	N/A	N/A	Apr. 06, 2016	N/A	Conduction (CO05-HY)
EMI Test Receiver	Rohde & Schwarz	ESCI 7	100724	9kHz~7GHz	Aug. 26, 2015	Apr. 06, 2016	Aug. 25, 2016	Conduction (CO05-HY)
LISN	Rohde & Schwarz	ENV216	100080	9kHz~30MHz	Dec. 02, 2015	Apr. 06, 2016	Dec. 01, 2016	Conduction (CO05-HY)
Loop Antenna	Rohde & Schwarz	HFH2-Z2	100315	9 kHz~30 MHz	Sep. 02, 2015	Apr. 14, 2016 ~ Apr. 21, 2016	Sep. 01, 2016	Radiation (03CH11-HY)
Amplifier	SONOMA	310N	187312	9kHz~1GHz	Nov. 20, 2015	Apr. 14, 2016 ~ Apr. 21, 2016	Nov. 19, 2016	Radiation (03CH11-HY)
Bilog Antenna	TESEQ	CBL 6111D	35414	30MHz~1GHz	Nov. 17, 2015	Apr. 14, 2016 ~ Apr. 21, 2016	Nov. 16, 2016	Radiation (03CH11-HY)
Horn Antenna	SCHWARZBECK	BBHA 9120 D	9120D-1326	1GHz ~ 18GHz	Oct. 08, 2015	Apr. 14, 2016 ~ Apr. 21, 2016	Oct. 07, 2016	Radiation (03CH11-HY)
Preamplifier	Keysight	83017A	MY53270080	1GHz~26.5GHz	Nov. 19, 2015	Apr. 14, 2016 ~ Apr. 21, 2016	Nov. 18, 2016	Radiation (03CH11-HY)
Preamplifier	MITEQ	AMF-7D-0010 1800-30-10P	1902247	1GHz~18GHz	Jul. 01, 2015	Apr. 14, 2016 ~ Apr. 21, 2016	Jun. 30, 2016	Radiation (03CH11-HY)
Spectrum Analyzer	Keysight	N9010A	MY54200486	10Hz ~ 44GHZ	Sep. 24, 2015	Apr. 14, 2016 ~ Apr. 21, 2016	Sep. 23, 2016	Radiation (03CH11-HY)
Antenna Mast	EMEC	AM-BS-4500-B	N/A	1~4m	N/A	Apr. 14, 2016 ~ Apr. 21, 2016	N/A	Radiation (03CH11-HY)
Turn Table	EMEC	TT 2000	N/A	0~360 Degree	N/A	Apr. 14, 2016 ~ Apr. 21, 2016	N/A	Radiation (03CH11-HY)
SHF-EHF Horn Antenna	SCHWARZBECK	BBHA 9170	BBHA91705 84	18GHz- 40GHz	Nov. 02, 2015	Apr. 14, 2016 ~ Apr. 21, 2016	Nov. 01, 2016	Radiation (03CH11-HY)
Preamplifier	MITEQ	JS44-180040 00-33-8P	1840917	18GHz ~ 40GHz	Jun. 02, 2015	Apr. 14, 2016 ~ Apr. 21, 2016	Jun. 01, 2016	Radiation (03CH11-HY)



5 Uncertainty of Evaluation

Uncertainty of Conducted Emission Measurement (150kHz ~ 30MHz)

Measuring Uncertainty for a Level of Confidence of 95% ($U = 2Uc(y)$)	2.26
---	------

Uncertainty of Radiated Emission Measurement (30 MHz ~ 1000 MHz)

Measuring Uncertainty for a Level of Confidence of 95% ($U = 2Uc(y)$)	4.90
---	------



Appendix A. Conducted Test Results

Test Engineer:	Luffy Lin	Temperature:	21~25	°C
Test Date:	2016/04/01~2016/04/25	Relative Humidity:	51~54	%

TEST RESULTS DATA
6dB and 99% Occupied Bandwidth

2.4GHz Band										
Mod.	Data Rate	NTX	CH.	Freq. (MHz)	99% Occupied BW (MHz)		6dB BW (MHz)		6dB BW Limit (MHz)	Pass/Fail
					Ant 1	Ant 2	Ant 1	Ant 2		
11b	1Mbps	1	1	2412	14.00	14.10	8.08	8.08	0.50	Pass
11b	1Mbps	1	6	2437	14.00	14.55	8.08	8.08	0.50	Pass
11b	1Mbps	1	11	2462	14.15	14.60	8.08	8.08	0.50	Pass
11g	6Mbps	1	1	2412	17.25	17.20	15.78	15.72	0.50	Pass
11g	6Mbps	1	6	2437	17.30	17.35	15.62	16.00	0.50	Pass
11g	6Mbps	1	11	2462	17.35	17.25	16.04	16.24	0.50	Pass
HT20	MCS0	1	1	2412	18.35	18.25	16.80	16.80	0.50	Pass
HT20	MCS0	1	6	2437	18.30	18.35	16.32	16.80	0.50	Pass
HT20	MCS0	1	11	2462	18.25	18.20	16.92	16.78	0.50	Pass
VHT20	MCS0	1	1	2412	18.15	18.25	16.82	16.80	0.50	Pass
VHT20	MCS0	1	6	2437	18.30	18.35	16.96	16.56	0.50	Pass
VHT20	MCS0	1	11	2462	18.25	18.20	17.16	16.90	0.50	Pass
11b	1Mbps	2	1	2412	14.05	14.10	8.04	8.04	0.50	Pass
11b	1Mbps	2	6	2437	14.00	14.55	8.08	8.12	0.50	Pass
11b	1Mbps	2	11	2462	14.35	14.65	8.56	8.08	0.50	Pass
11g	6Mbps	2	1	2412	17.20	17.15	16.28	15.76	0.50	Pass
11g	6Mbps	2	6	2437	17.25	17.35	15.70	16.00	0.50	Pass
11g	6Mbps	2	11	2462	17.30	17.30	16.30	15.68	0.50	Pass
HT20	MCS0	2	1	2412	18.20	18.20	16.80	16.76	0.50	Pass
HT20	MCS0	2	6	2437	18.30	18.35	16.32	16.90	0.50	Pass
HT20	MCS0	2	11	2462	18.30	18.30	17.16	16.78	0.50	Pass
VHT20	MCS0	2	1	2412	18.25	18.20	16.80	16.52	0.50	Pass
VHT20	MCS0	2	6	2437	18.25	18.40	16.56	16.56	0.50	Pass
VHT20	MCS0	2	11	2462	18.25	18.25	17.16	16.80	0.50	Pass

TEST RESULTS DATA
Peak Output Power

2.4GHz Band											
Mod.	Data Rate	NTX	CH.	Freq. (MHz)	Peak Conducted Power (dBm)			DG (dBi)		EIRP Power (dBm)	
					Ant 1	Ant 2	SUM	Ant 1	Ant 2	Ant 1	Ant 2
11b	1Mbps	1	1	2412	19.59	16.66		-3.70	-1.50	15.89	15.16
11b	1Mbps	1	6	2437	20.67	16.97		-3.70	-1.50	16.97	15.47
11b	1Mbps	1	11	2462	21.09	17.00		-3.70	-1.50	17.39	15.50
11g	6Mbps	1	1	2412	22.00	18.66		-3.70	-1.50	18.30	17.16
11g	6Mbps	1	6	2437	22.37	18.47		-3.70	-1.50	18.67	16.97
11g	6Mbps	1	11	2462	21.95	17.75		-3.70	-1.50	18.25	16.25
HT20	MCS0	1	1	2412	21.96	18.78		-3.70	-1.50	18.26	17.28
HT20	MCS0	1	6	2437	22.33	18.67		-3.70	-1.50	18.63	17.17
HT20	MCS0	1	11	2462	21.75	17.75		-3.70	-1.50	18.05	16.25
VHT20	MCS0	1	1	2412	21.97	18.76		-3.70	-1.50	18.27	17.26
VHT20	MCS0	1	6	2437	22.12	18.86		-3.70	-1.50	18.42	17.36
VHT20	MCS0	1	11	2462	21.41	17.23		-3.70	-1.50	17.71	15.73
11b	1Mbps	2	1	2412	18.97	15.76	20.67	-1.50		19.17	
11b	1Mbps	2	6	2437	20.03	16.25	21.55	-1.50		20.05	
11b	1Mbps	2	11	2462	20.42	16.29	21.84	-1.50		20.34	
11g	6Mbps	2	1	2412	21.24	17.72	22.84	-1.50		21.34	
11g	6Mbps	2	6	2437	21.57	17.74	23.07	-1.50		21.57	
11g	6Mbps	2	11	2462	21.02	17.05	22.48	-1.50		20.98	
HT20	MCS0	2	1	2412	21.48	17.83	23.04	-1.50		21.54	
HT20	MCS0	2	6	2437	21.56	17.96	23.13	-1.50		21.63	
HT20	MCS0	2	11	2462	21.04	16.76	22.42	-1.50		20.92	
VHT20	MCS0	2	1	2412	21.45	17.83	23.02	-1.50		21.52	
VHT20	MCS0	2	6	2437	21.55	17.83	23.09	-1.50		21.59	
VHT20	MCS0	2	11	2462	20.60	16.52	22.03	-1.50		20.53	

Note: Measured power (dBm) has offset with cable loss.

TEST RESULTS DATA
Average Output Power

2.4GHz Band																		
Mod.	Data Rate	NTx	CH.	Freq. (MHz)	Duty Factor (dB)		Average Conducted Power (dBm)			Conducted Power Limit (dBm)		DG (dBi)		EIRP Power (dBm)		EIRP Power Limit (dBm)		Pass /Fail
					Ant 1	Ant 2	Ant 1	Ant 2	SUM	Ant 1	Ant 2	Ant 1	Ant 2	Ant 1	Ant 2	Ant 1	Ant 2	
11b	1Mbps	1	1	2412	0.04	0.04	17.30	14.35		30.00	30.00	-3.70	-1.50	13.60	12.85	36.00	36.00	Pass
11b	1Mbps	1	6	2437	0.04	0.04	18.48	14.88		30.00	30.00	-3.70	-1.50	14.78	13.38	36.00	36.00	Pass
11b	1Mbps	1	11	2462	0.04	0.04	18.91	14.96		30.00	30.00	-3.70	-1.50	15.21	13.46	36.00	36.00	Pass
11g	6Mbps	1	1	2412	0.25	0.25	16.54	13.41		30.00	30.00	-3.70	-1.50	12.84	11.91	36.00	36.00	Pass
11g	6Mbps	1	6	2437	0.25	0.25	17.30	13.73		30.00	30.00	-3.70	-1.50	13.60	12.23	36.00	36.00	Pass
11g	6Mbps	1	11	2462	0.25	0.25	16.18	12.47		30.00	30.00	-3.70	-1.50	12.48	10.97	36.00	36.00	Pass
HT20	MCS0	1	1	2412	0.22	0.22	16.35	13.19		30.00	30.00	-3.70	-1.50	12.65	11.69	36.00	36.00	Pass
HT20	MCS0	1	6	2437	0.22	0.22	16.81	13.58		30.00	30.00	-3.70	-1.50	13.11	12.08	36.00	36.00	Pass
HT20	MCS0	1	11	2462	0.22	0.22	15.51	11.82		30.00	30.00	-3.70	-1.50	11.81	10.32	36.00	36.00	Pass
VHT20	MCS0	1	1	2412	0.26	0.26	16.44	13.17		30.00	30.00	-3.70	-1.50	12.74	11.67	36.00	36.00	Pass
VHT20	MCS0	1	6	2437	0.26	0.26	16.75	13.59		30.00	30.00	-3.70	-1.50	13.05	12.09	36.00	36.00	Pass
VHT20	MCS0	1	11	2462	0.26	0.26	14.97	11.28		30.00	30.00	-3.70	-1.50	11.27	9.78	36.00	36.00	Pass
11b	1Mbps	2	1	2412	0.04	0.04	16.75	13.48	18.43	30.00		-1.50		16.93		36.00		Pass
11b	1Mbps	2	6	2437	0.04	0.04	17.89	14.11	19.41	30.00		-1.50		17.91		36.00		Pass
11b	1Mbps	2	11	2462	0.04	0.04	18.39	14.24	19.80	30.00		-1.50		18.30		36.00		Pass
11g	6Mbps	2	1	2412	0.25	0.25	15.90	12.34	17.48	30.00		-1.50		15.98		36.00		Pass
11g	6Mbps	2	6	2437	0.25	0.25	16.66	12.89	18.18	30.00		-1.50		16.68		36.00		Pass
11g	6Mbps	2	11	2462	0.25	0.25	15.36	11.72	16.92	30.00		-1.50		15.42		36.00		Pass
HT20	MCS0	2	1	2412	0.26	0.31	15.79	12.22	17.37	30.00		-1.50		15.87		36.00		Pass
HT20	MCS0	2	6	2437	0.26	0.31	16.05	12.90	17.77	30.00		-1.50		16.27		36.00		Pass
HT20	MCS0	2	11	2462	0.26	0.31	14.75	11.22	16.35	30.00		-1.50		14.85		36.00		Pass
VHT20	MCS0	2	1	2412	0.26	0.26	15.82	12.28	17.41	30.00		-1.50		15.91		36.00		Pass
VHT20	MCS0	2	6	2437	0.26	0.26	16.05	12.90	17.77	30.00		-1.50		16.27		36.00		Pass
VHT20	MCS0	2	11	2462	0.26	0.26	14.28	10.74	15.87	30.00		-1.50		14.37		36.00		Pass

Note: Measured power (dBm) has offset with cable loss.

TEST RESULTS DATA
Average Power Spectral Density

2.4GHz Band												
Mod.	Data Rate	NTX	CH.	Freq. (MHz)	Average PSD (dBm/3kHz)			DG (dBi)		Average PSD Limit (dBm/3kHz)		Pass/Fail
					Ant 1	Ant 2	Worse + 3.01	Ant 1	Ant 2	Ant 1	Ant 2	
11b	1Mbps	1	1	2412	-10.16	-13.76	-	-3.70	-1.50	8.00	8.00	Pass
11b	1Mbps	1	6	2437	-9.07	-10.40	-	-3.70	-1.50	8.00	8.00	Pass
11b	1Mbps	1	11	2462	-6.23	-10.76	-	-3.70	-1.50	8.00	8.00	Pass
11g	6Mbps	1	1	2412	-15.73	-19.10	-	-3.70	-1.50	8.00	8.00	Pass
11g	6Mbps	1	6	2437	-15.09	-18.54	-	-3.70	-1.50	8.00	8.00	Pass
11g	6Mbps	1	11	2462	-15.99	-20.11	-	-3.70	-1.50	8.00	8.00	Pass
HT20	MCS0	1	1	2412	-16.37	-19.74	-	-3.70	-1.50	8.00	8.00	Pass
HT20	MCS0	1	6	2437	-15.72	-19.40	-	-3.70	-1.50	8.00	8.00	Pass
HT20	MCS0	1	11	2462	-17.43	-20.75	-	-3.70	-1.50	8.00	8.00	Pass
VHT20	MCS0	1	1	2412	-16.70	-19.92	-	-3.70	-1.50	8.00	8.00	Pass
VHT20	MCS0	1	6	2437	-15.90	-19.26	-	-3.70	-1.50	8.00	8.00	Pass
VHT20	MCS0	1	11	2462	-18.11	-21.82	-	-3.70	-1.50	8.00	8.00	Pass
11b	1Mbps	2	1	2412	-11.18	-14.59	-8.17	0.48		8.00		Pass
11b	1Mbps	2	6	2437	-8.20	-9.21	-5.19	0.48		8.00		Pass
11b	1Mbps	2	11	2462	-5.06	-11.22	-2.05	0.48		8.00		Pass
11g	6Mbps	2	1	2412	-16.71	-20.03	-13.70	0.48		8.00		Pass
11g	6Mbps	2	6	2437	-16.19	-19.22	-13.18	0.48		8.00		Pass
11g	6Mbps	2	11	2462	-17.27	-20.13	-14.26	0.48		8.00		Pass
HT20	MCS0	2	1	2412	-17.27	-20.58	-14.26	0.48		8.00		Pass
HT20	MCS0	2	6	2437	-16.68	-19.96	-13.67	0.48		8.00		Pass
HT20	MCS0	2	11	2462	-18.39	-21.87	-15.38	0.48		8.00		Pass
VHT20	MCS0	2	1	2412	-17.50	-20.54	-14.49	0.48		8.00		Pass
VHT20	MCS0	2	6	2437	-16.64	-20.05	-13.63	0.48		8.00		Pass
VHT20	MCS0	2	11	2462	-18.76	-22.38	-15.75	0.48		8.00		Pass

Measured power density (dBm) has offset with cable loss.



Appendix B. Radiated Spurious Emission

Test Engineer :	J.C. Liang and Bill Chang and Ken Wu	Temperature :	19~21°C
		Relative Humidity :	50~55%

2.4GHz 2400~2483.5MHz

WIFI 802.11b (Band Edge @ 3m)

WIFI Ant. 1+2	Note	Frequency (MHz)	Level (dBμV/m)	Over Limit (dB)	Limit Line (dBμV/m)	Read Level (dBμV)	Antenna Factor (dB/m)	Cable Loss (dB)	Preamp Factor (dB)	Ant Pos (cm)	Table Pos (deg)	Peak Avg. (P/A)	Pol. (H/V)	
802.11b CH 01 2412MHz		2385.33	53.73	-20.27	74	54.05	26.96	6.71	33.99	298	137	P	H	
		2385.42	45.76	-8.24	54	46.08	26.96	6.71	33.99	298	137	A	H	
	*	2412	106.61	-	-	106.82	27.06	6.71	33.98	298	137	P	H	
	*	2412	104	-	-	104.21	27.06	6.71	33.98	298	137	A	H	
													H	
														H
			2387.04	57.69	-16.31	74	57.96	27.01	6.71	33.99	345	99	P	V
			2385.51	50.72	-3.28	54	50.99	27.01	6.71	33.99	345	99	A	V
	*		2412	110.22	-	-	110.43	27.06	6.71	33.98	345	99	P	V
	*		2412	107.33	-	-	107.54	27.06	6.71	33.98	345	99	A	V
														V
														V
802.11b CH 06 2437MHz		2352.39	51	-23	74	51.43	26.91	6.65	33.99	367	136	P	H	
		2390	40.34	-13.66	54	40.6	27.01	6.71	33.98	367	136	A	H	
	*	2437	105.53	-	-	105.6	27.16	6.74	33.97	367	136	P	H	
	*	2437	102.97	-	-	103.04	27.16	6.74	33.97	367	136	A	H	
			2493.12	51.63	-22.37	74	51.5	27.3	6.77	33.94	367	136	P	H
			2483.6	40.84	-13.16	54	40.77	27.25	6.77	33.95	367	136	A	H
			2318.55	51.9	-22.1	74	52.5	26.82	6.58	34	111	88	P	V
			2390	41.41	-12.59	54	41.67	27.01	6.71	33.98	111	88	A	V
	*		2437	110.06	-	-	110.13	27.16	6.74	33.97	111	88	P	V
	*		2437	107.74	-	-	107.81	27.16	6.74	33.97	111	88	A	V
			2485	52.13	-21.87	74	52.06	27.25	6.77	33.95	111	88	P	V
			2484.96	41.61	-12.39	54	41.54	27.25	6.77	33.95	111	88	A	V



802.11b CH 11 2462MHz	*	2462	107.27	-	-	107.26	27.2	6.77	33.96	296	50	P	H
	*	2462	104.83	-	-	104.82	27.2	6.77	33.96	296	50	A	H
		2486.16	56.39	-17.61	74	56.32	27.25	6.77	33.95	296	50	P	H
		2488.16	50.04	-3.96	54	49.92	27.3	6.77	33.95	296	50	A	H
													H
													H
	*	2462	109.89	-	-	109.88	27.2	6.77	33.96	151	87	P	V
	*	2462	106.81	-	-	106.8	27.2	6.77	33.96	151	87	A	V
		2488.08	57.99	-16.01	74	57.87	27.3	6.77	33.95	151	87	P	V
		2487	53.75	-0.25	54	53.68	27.25	6.77	33.95	151	87	A	V
													V
													V
Remark	1. No other spurious found. 2. All results are PASS against Peak and Average limit line.												



**2.4GHz 2400~2483.5MHz
WIFI 802.11b (Harmonic @ 3m)**

WIFI Ant. 1+2	Note	Frequency (MHz)	Level (dBµV/m)	Over Limit (dB)	Limit Line (dBµV/m)	Read Level (dBµV)	Antenna Factor (dB/m)	Cable Loss (dB)	Preamp Factor (dB)	Ant Pos (cm)	Table Pos (deg)	Peak Avg. (P/A)	Pol. (H/V)	
802.11b CH 01 2412MHz		4824	53.77	-20.23	74	77.14	31.12	10.58	65.07	212	122	P	H	
		4824	52.79	-1.21	54	76.16	31.12	10.58	65.07	212	122	A	H	
													H	
													H	
			4824	46.5	-27.5	74	69.87	31.12	10.58	65.07	100	0	P	V
														V
														V
802.11b CH 06 2437MHz		4874	47.58	-26.42	74	70.91	31.21	10.48	65.02	100	0	P	H	
		7311	51.98	-22.02	74	68.68	36.08	12.28	65.06	203	166	P	H	
		7311	48.49	-5.51	54	65.19	36.08	12.28	65.06	203	166	A	H	
													H	
			4874	47.88	-26.12	74	71.21	31.21	10.48	65.02	100	0	P	V
			7311	47.35	-26.65	74	64.05	36.08	12.28	65.06	100	0	P	V
														V
802.11b CH 11 2462MHz		4924	48.26	-25.74	74	71.55	31.29	10.39	64.97	100	0	P	H	
		7386	47.29	-26.71	74	63.61	36.27	12.49	65.08	100	0	P	H	
													H	
													H	
			4924	46.37	-27.63	74	69.66	31.29	10.39	64.97	100	0	P	V
			7386	45.15	-28.85	74	61.47	36.27	12.49	65.08	100	0	P	V
														V
Remark	1. No other spurious found.													
	2. All results are PASS against Peak and Average limit line.													



**2.4GHz 2400~2483.5MHz
WIFI 802.11g (Band Edge @ 3m)**

WIFI Ant. 1+2	Note	Frequency (MHz)	Level (dBμV/m)	Over Limit (dB)	Limit Line (dBμV/m)	Read Level (dBμV)	Antenna Factor (dB/m)	Cable Loss (dB)	Preamp Factor (dB)	Ant Pos (cm)	Table Pos (deg)	Peak Avg. (P/A)	Pol. (H/V)	
802.11g CH 01 2412MHz		2390	59.45	-14.55	74	59.71	27.01	6.71	33.98	279	66	P	H	
		2390	50.85	-3.15	54	51.11	27.01	6.71	33.98	279	66	A	H	
	*	2412	107.57	-	-	107.78	27.06	6.71	33.98	279	66	P	H	
	*	2412	99.53	-	-	99.74	27.06	6.71	33.98	279	66	A	H	
													H	
													H	
			2389.92	62.18	-11.82	74	62.44	27.01	6.71	33.98	134	91	P	V
			2390	53.35	-0.65	54	53.61	27.01	6.71	33.98	134	91	A	V
	*		2412	108.3	-	-	108.51	27.06	6.71	33.98	134	91	P	V
	*		2412	100.7	-	-	100.91	27.06	6.71	33.98	134	91	A	V
													V	
													V	
802.11g CH 06 2437MHz		2389.47	51.47	-22.53	74	51.74	27.01	6.71	33.99	273	129	P	H	
		2389.02	42.13	-11.87	54	42.4	27.01	6.71	33.99	273	129	A	H	
	*	2437	109.26	-	-	109.33	27.16	6.74	33.97	273	129	P	H	
	*	2437	101.29	-	-	101.36	27.16	6.74	33.97	273	129	A	H	
			2484	52.05	-21.95	74	51.98	27.25	6.77	33.95	273	129	P	H
			2484.8	42.38	-11.62	54	42.31	27.25	6.77	33.95	273	129	A	H
			2389.2	53.07	-20.93	74	53.34	27.01	6.71	33.99	104	110	P	V
			2389.02	43.54	-10.46	54	43.81	27.01	6.71	33.99	104	110	A	V
	*		2437	111.39	-	-	111.46	27.16	6.74	33.97	104	110	P	V
	*		2437	103.46	-	-	103.53	27.16	6.74	33.97	104	110	A	V
			2485.24	52.36	-21.64	74	52.29	27.25	6.77	33.95	104	110	P	V
			2485.16	43.22	-10.78	54	43.15	27.25	6.77	33.95	104	110	A	V



802.11g CH 11 2462MHz	*	2462	104.63	-	-	104.62	27.2	6.77	33.96	100	115	P	H
	*	2462	97.33	-	-	97.32	27.2	6.77	33.96	100	115	A	H
		2484.12	60.96	-13.04	74	60.89	27.25	6.77	33.95	100	115	P	H
		2483.56	51.16	-2.84	54	51.09	27.25	6.77	33.95	100	115	A	H
													H
													H
	*	2462	107.76	-	-	107.75	27.2	6.77	33.96	155	115	P	V
	*	2462	100.11	-	-	100.1	27.2	6.77	33.96	155	115	A	V
		2483.52	63.29	-10.71	74	63.22	27.25	6.77	33.95	155	115	P	V
		2483.6	53.3	-0.7	54	53.23	27.25	6.77	33.95	155	115	A	V
													V
													V
Remark	1. No other spurious found. 2. All results are PASS against Peak and Average limit line.												



**2.4GHz 2400~2483.5MHz
WIFI 802.11g (Harmonic @ 3m)**

WIFI Ant. 1+2	Note	Frequency (MHz)	Level (dBμV/m)	Over Limit (dB)	Limit Line (dBμV/m)	Read Level (dBμV)	Antenna Factor (dB/m)	Cable Loss (dB)	Preamp Factor (dB)	Ant Pos (cm)	Table Pos (deg)	Peak Avg. (P/A)	Pol. (H/V)	
802.11g CH 01 2412MHz		4824	47.21	-26.79	74	70.58	31.12	10.58	65.07	100	0	P	H	
													H	
													H	
													H	
			4824	43.12	-30.88	74	66.49	31.12	10.58	65.07	100	0	P	V
														V
														V
802.11g CH 06 2437MHz		4874	47.7	-26.3	74	71.03	31.21	10.48	65.02	100	0	P	H	
		7311	47.25	-26.75	74	63.95	36.08	12.28	65.06	100	0	P	H	
													H	
													H	
			4874	48.43	-25.57	74	71.76	31.21	10.48	65.02	100	0	P	V
			7311	41.4	-32.6	74	58.1	36.08	12.28	65.06	100	0	P	V
														V
802.11g CH 11 2462MHz		4924	43.26	-30.74	74	66.55	31.29	10.39	64.97	100	0	P	H	
		7386	41.78	-32.22	74	58.1	36.27	12.49	65.08	100	0	P	H	
													H	
													H	
			4924	41.91	-32.09	74	65.2	31.29	10.39	64.97	100	0	P	V
			7386	40.65	-33.35	74	56.97	36.27	12.49	65.08	100	0	P	V
														V
Remark	1. No other spurious found.													
	2. All results are PASS against Peak and Average limit line.													



**2.4GHz 2400~2483.5MHz
WIFI 802.11n HT20 (Band Edge @ 3m)**

WIFI Ant. 1+2	Note	Frequency (MHz)	Level (dBμV/m)	Over Limit (dB)	Limit Line (dBμV/m)	Read Level (dBμV)	Antenna Factor (dB/m)	Cable Loss (dB)	Preamp Factor (dB)	Ant Pos (cm)	Table Pos (deg)	Peak Avg. (P/A)	Pol. (H/V)	
802.11n HT20 CH 01 2412MHz		2389.92	60.49	-13.51	74	60.75	27.01	6.71	33.98	265	128	P	H	
		2390	50.1	-3.9	54	50.36	27.01	6.71	33.98	265	128	A	H	
	*	2412	106.79	-	-	107	27.06	6.71	33.98	265	128	P	H	
	*	2412	98.95	-	-	99.16	27.06	6.71	33.98	265	128	A	H	
													H	
														H
			2389.83	62.99	-11.01	74	63.25	27.01	6.71	33.98	349	98	P	V
			2390	53.66	-0.34	54	53.92	27.01	6.71	33.98	349	98	A	V
		*	2412	109.11	-	-	109.32	27.06	6.71	33.98	349	98	P	V
		*	2412	101.4	-	-	101.61	27.06	6.71	33.98	349	98	A	V
													V	
													V	
802.11n HT20 CH 06 2437MHz		2358.87	52.15	-21.85	74	52.58	26.91	6.65	33.99	293	125	P	H	
		2388.75	41.8	-12.2	54	42.07	27.01	6.71	33.99	293	125	A	H	
	*	2437	107.84	-	-	107.91	27.16	6.74	33.97	293	125	P	H	
	*	2437	100.2	-	-	100.27	27.16	6.74	33.97	293	125	A	H	
			2484.52	52.41	-21.59	74	52.34	27.25	6.77	33.95	293	125	P	H
			2483.72	42.32	-11.68	54	42.25	27.25	6.77	33.95	293	125	A	H
			2389.11	52.18	-21.82	74	52.45	27.01	6.71	33.99	309	122	P	V
			2389.11	42.9	-11.1	54	43.17	27.01	6.71	33.99	309	122	A	V
		*	2437	111.67	-	-	111.74	27.16	6.74	33.97	309	122	P	V
		*	2437	103.8	-	-	103.87	27.16	6.74	33.97	309	122	A	V
		2488.72	52.07	-21.93	74	51.95	27.3	6.77	33.95	309	122	P	V	
		2485.12	43.31	-10.69	54	43.24	27.25	6.77	33.95	309	122	A	V	



802.11n HT20 CH 11 2462MHz	*	2462	106.26	-	-	106.25	27.2	6.77	33.96	239	76	P	H
	*	2462	98.54	-	-	98.53	27.2	6.77	33.96	239	76	A	H
		2484.04	63.1	-10.9	74	63.03	27.25	6.77	33.95	239	76	P	H
		2483.52	52.83	-1.17	54	52.76	27.25	6.77	33.95	239	76	A	H
													H
													H
	*	2463.794	107.78	-	-	107.77	27.2	6.77	33.96	234	127	P	V
	*	2463.376	100.1	-	-	100.09	27.2	6.77	33.96	234	127	A	V
		2483.96	59.67	-14.33	74	59.6	27.25	6.77	33.95	234	127	P	V
		2483.56	52.45	-1.55	54	52.38	27.25	6.77	33.95	234	127	A	V
												V	
												V	
Remark	1. No other spurious found. 2. All results are PASS against Peak and Average limit line.												



**2.4GHz 2400~2483.5MHz
WIFI 802.11n HT20 (Harmonic @ 3m)**

WIFI Ant. 1+2	Note	Frequency (MHz)	Level (dBμV/m)	Over Limit (dB)	Limit Line (dBμV/m)	Read Level (dBμV)	Antenna Factor (dB/m)	Cable Loss (dB)	Preamp Factor (dB)	Ant Pos (cm)	Table Pos (deg)	Peak Avg. (P/A)	Pol. (H/V)	
802.11n HT20 CH 01 2412MHz		4824	47.5	-26.5	74	70.87	31.12	10.58	65.07	100	0	P	H	
													H	
													H	
													H	
			4824	46.43	-27.57	74	69.8	31.12	10.58	65.07	100	0	P	V
														V
														V
802.11n HT20 CH 06 2437MHz		4874	47.05	-26.95	74	70.38	31.21	10.48	65.02	100	0	P	H	
		7311	49.39	-24.61	74	66.09	36.08	12.28	65.06	100	0	P	H	
													H	
													H	
			4874	47.56	-26.44	74	70.89	31.21	10.48	65.02	100	0	P	V
			7311	42.66	-31.34	74	59.36	36.08	12.28	65.06	100	0	P	V
														V
802.11n HT20 CH 11 2462MHz		4924	45.32	-28.68	74	68.61	31.29	10.39	64.97	100	0	P	H	
		7386	42	-32	74	58.32	36.27	12.49	65.08	100	0	P	H	
													H	
													H	
			4924	41.48	-32.52	74	64.77	31.29	10.39	64.97	100	0	P	V
			7386	40.04	-33.96	74	56.36	36.27	12.49	65.08	100	0	P	V
														V
Remark	1. No other spurious found.													
	2. All results are PASS against Peak and Average limit line.													



**2.4GHz 2400~2483.5MHz
WIFI 802.11ac VHT20 (Band Edge @ 3m)**

WIFI Ant. 1+2	Note	Frequency (MHz)	Level (dBμV/m)	Over Limit (dB)	Limit Line (dBμV/m)	Read Level (dBμV)	Antenna Factor (dB/m)	Cable Loss (dB)	Preamp Factor (dB)	Ant Pos (cm)	Table Pos (deg)	Peak Avg. (P/A)	Pol. (H/V)	
802.11ac VHT20 CH 01 2412MHz		2389.92	60.34	-13.66	74	60.6	27.01	6.71	33.98	305	43	P	H	
		2390	50.2	-3.8	54	50.46	27.01	6.71	33.98	305	43	A	H	
	*	2412	106.79	-	-	107	27.06	6.71	33.98	305	43	P	H	
	*	2412	99.18	-	-	99.39	27.06	6.71	33.98	305	43	A	H	
													H	
														H
			2389.47	62.31	-11.69	74	62.58	27.01	6.71	33.99	201	130	P	V
			2390	52.26	-1.74	54	52.52	27.01	6.71	33.98	201	130	A	V
		*	2411.606	109.57	-	-	109.78	27.06	6.71	33.98	201	130	P	V
		*	2410.688	101.47	-	-	101.68	27.06	6.71	33.98	201	130	A	V
													V	
													V	
802.11ac VHT20 CH 06 2437MHz		2388.93	52.06	-21.94	74	52.33	27.01	6.71	33.99	295	45	P	H	
		2389.92	42.57	-11.43	54	42.83	27.01	6.71	33.98	295	45	A	H	
	*	2437	109.44	-	-	109.51	27.16	6.74	33.97	295	45	P	H	
	*	2437	102.36	-	-	102.43	27.16	6.74	33.97	295	45	A	H	
			2488.84	51.96	-22.04	74	51.84	27.3	6.77	33.95	295	45	P	H
			2484.68	42.96	-11.04	54	42.89	27.25	6.77	33.95	295	45	A	H
			2387.31	53.81	-20.19	74	54.08	27.01	6.71	33.99	200	99	P	V
			2389.2	43.64	-10.36	54	43.91	27.01	6.71	33.99	200	99	A	V
		*	2437	111.03	-	-	111.1	27.16	6.74	33.97	200	99	P	V
		*	2437	103.07	-	-	103.14	27.16	6.74	33.97	200	99	A	V
		2485.04	52.89	-21.11	74	52.82	27.25	6.77	33.95	200	99	P	V	
		2484.76	43.1	-10.9	54	43.03	27.25	6.77	33.95	200	99	A	V	



802.11ac VHT20 CH 11 2462MHz	*	2462	105.69	-	-	105.68	27.2	6.77	33.96	324	37	P	H
	*	2462	97.97	-	-	97.96	27.2	6.77	33.96	324	37	A	H
		2484.04	63.16	-10.84	74	63.09	27.25	6.77	33.95	324	37	P	H
		2483.64	52.56	-1.44	54	52.49	27.25	6.77	33.95	324	37	A	H
													H
													H
	*	2460.705	107.6	-	-	107.59	27.2	6.77	33.96	201	96	P	V
	*	2460.705	99.77	-	-	99.76	27.2	6.77	33.96	201	96	A	V
		2484.04	63.39	-10.61	74	63.32	27.25	6.77	33.95	201	96	P	V
		2483.6	53.06	-0.94	54	52.99	27.25	6.77	33.95	201	96	A	V
												V	
												V	
Remark	1. No other spurious found. 2. All results are PASS against Peak and Average limit line.												



**2.4GHz 2400~2483.5MHz
WIFI 802.11ac VHT20 (Harmonic @ 3m)**

WIFI Ant. 1+2	Note	Frequency (MHz)	Level (dBμV/m)	Over Limit (dB)	Limit Line (dBμV/m)	Read Level (dBμV)	Antenna Factor (dB/m)	Cable Loss (dB)	Preamp Factor (dB)	Ant Pos (cm)	Table Pos (deg)	Peak Avg. (P/A)	Pol. (H/V)	
802.11ac VHT20 CH 01 2412MHz		4824	48.08	-25.92	74	71.45	31.12	10.58	65.07	100	0	P	H	
													H	
													H	
													H	
			4824	42.5	-31.5	74	65.87	31.12	10.58	65.07	100	0	P	V
														V
														V
802.11ac VHT20 CH 06 2437MHz		4874	48.99	-25.01	74	72.32	31.21	10.48	65.02	100	0	P	H	
		7311	48.71	-25.29	74	65.41	36.08	12.28	65.06	100	0	P	H	
													H	
													H	
			4874	45.88	-28.12	74	69.21	31.21	10.48	65.02	100	0	P	V
			7311	43.11	-30.89	74	59.81	36.08	12.28	65.06	100	0	P	V
														V
802.11ac VHT20 CH 11 2462MHz		4924	44.27	-29.73	74	67.56	31.29	10.39	64.97	100	0	P	H	
		7386	39.65	-34.35	74	55.97	36.27	12.49	65.08	100	0	P	H	
													H	
													H	
			4924	40.41	-33.59	74	63.7	31.29	10.39	64.97	100	0	P	V
			7386	39.84	-34.16	74	56.16	36.27	12.49	65.08	100	0	P	V
														V
Remark	1. No other spurious found.													
	2. All results are PASS against Peak and Average limit line.													



2.4GHz 2400~2483.5MHz

Emission below 1GHz

2.4GHz WIFI 802.11b (LF)

WIFI Ant.	Note	Frequency	Level	Over Limit	Limit Line	Read Level	Antenna Factor	Cable Loss	Preamp Factor	Ant Pos	Table Pos	Peak Avg.	Pol.	
1+2		(MHz)	(dBμV/m)	(dB)	(dBμV/m)	(dBμV)	(dB/m)	(dB)	(dB)	(cm)	(deg)	(P/A)	(H/V)	
2.4GHz 802.11b LF		78.33	26.32	-13.68	40	43.48	13.46	1.17	31.79			P	H	
		126.12	38.74	-4.76	43.5	51.16	17.88	1.48	31.78	105	284	P	H	
		204.96	28.23	-15.27	43.5	42.18	16.09	1.74	31.78			P	H	
		443.5	26.15	-19.85	46	31.13	23.18	3.68	31.84			P	H	
		720	30.96	-15.04	46	32.35	27.09	3.54	32.02			P	H	
		930	33.58	-12.42	46	30.86	30.05	3.86	31.19			P	H	
														H
														H
														H
														H
														H
			45.12	36.46	-3.54	40	50.27	17.07	0.93	31.81	179	125	P	V
			122.07	33.11	-10.39	43.5	45.65	17.76	1.48	31.78			P	V
			203.61	30.98	-12.52	43.5	44.95	16.07	1.74	31.78			P	V
			304.9	25.06	-20.94	46	34.76	19.83	2.23	31.76			P	V
			701.8	27.61	-18.39	46	29.37	26.74	3.54	32.04			P	V
			925.1	32.74	-13.26	46	30.2	29.91	3.86	31.23			P	V
														V
														V
														V
													V	
													V	
Remark	1. No other spurious found. 2. All results are PASS against limit line.													



Note symbol

*	Fundamental Frequency which can be ignored. However, the level of any unwanted emissions shall not exceed the level of the fundamental frequency.
!	Test result is over limit line.
P/A	Peak or Average
H/V	Horizontal or Vertical



A calculation example for radiated spurious emission is shown as below:

WIFI	Note	Frequency	Level	Over	Limit	Read	Antenna	Cable	Preamp	Ant	Table	Peak	Pol.
Ant.				Limit	Line	Level	Factor	Loss	Factor	Pos	Pos	Avg.	
1+2		(MHz)	(dBμV/m)	(dB)	(dBμV/m)	(dBμV)	(dB/m)	(dB)	(dB)	(cm)	(deg)	(P/A)	(H/V)
802.11b		2390	55.45	-18.55	74	54.51	32.22	4.58	35.86	103	308	P	H
CH 01													
2412MHz		2390	43.54	-10.46	54	42.6	32.22	4.58	35.86	103	308	A	H

- Level(dBμV/m) =
Antenna Factor(dB/m) + Cable Loss(dB) + Read Level(dBμV) - Preamp Factor(dB)
- Over Limit(dB) = Level(dBμV/m) – Limit Line(dBμV/m)

For Peak Limit @ 2390MHz:

- Level(dBμV/m)
= Antenna Factor(dB/m) + Cable Loss(dB) + Read Level(dBμV) - Preamp Factor(dB)
= 32.22(dB/m) + 4.58(dB) + 54.51(dBμV) – 35.86 (dB)
= 55.45 (dBμV/m)
- Over Limit(dB)
= Level(dBμV/m) – Limit Line(dBμV/m)
= 55.45(dBμV/m) – 74(dBμV/m)
= -18.55(dB)

For Average Limit @ 2390MHz:

- Level(dBμV/m)
= Antenna Factor(dB/m) + Cable Loss(dB) + Read Level(dBμV) - Preamp Factor(dB)
= 32.22(dB/m) + 4.58(dB) + 42.6(dBμV) – 35.86 (dB)
= 43.54 (dBμV/m)
- Over Limit(dB)
= Level(dBμV/m) – Limit Line(dBμV/m)
= 43.54(dBμV/m) – 54(dBμV/m)
= -10.46(dB)

Both peak and average measured complies with the limit line, so test result is “PASS”.



Appendix C. Radiated Spurious Emission Plots

Test Engineer :	J.C. Liang and Bill Chang and Ken Wu	Temperature :	19~21°C
		Relative Humidity :	50~55%

Note symbol

-L	Low channel location
-R	High channel location

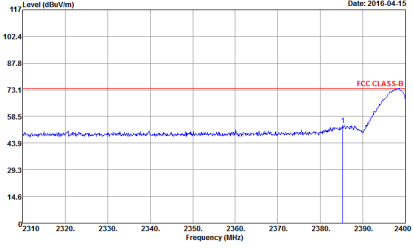
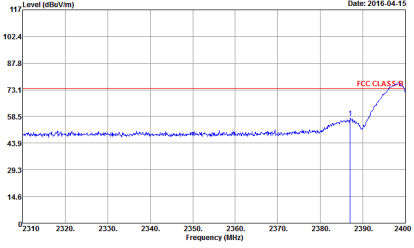
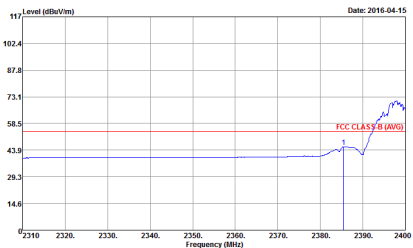
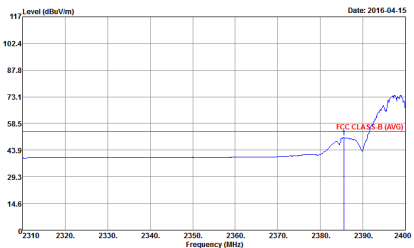

2.4GHz 2400~2483.5MHz
WIFI 802.11b (Band Edge @ 3m)

WIFI	2.4GHz 2400~2483.5MHz Band Edge @ 3m	
ANT	802.11b CH01 2412MHz	
1+2	Horizontal	Vertical
Peak	 <p>Site : 03CH11-HY Condition : FCC CLASS-B 3m HORN 9120D-HF HORIZONTAL Detector : Peak Project : 631828 Mode : 9</p>	 <p>Site : 03CH11-HY Condition : FCC CLASS-B 3m HORN 9120D-HF VERTICAL Detector : Peak Project : 631828 Mode : 9</p>
Avg.	 <p>Site : 03CH11-HY Condition : FCC CLASS-B (AVG) 3m HORN 9120D-HF HORIZONTAL Detector : Peak Project : 631828 Mode : 9</p>	 <p>Site : 03CH11-HY Condition : FCC CLASS-B (AVG) 3m HORN 9120D-HF VERTICAL Detector : Peak Project : 631828 Mode : 9</p>

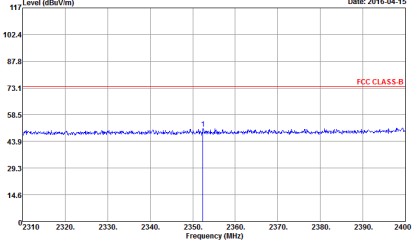
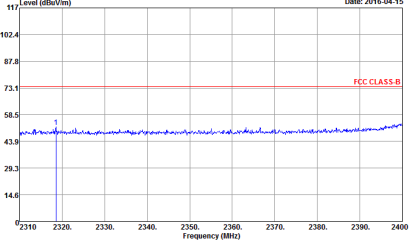
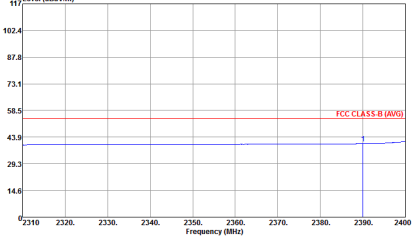
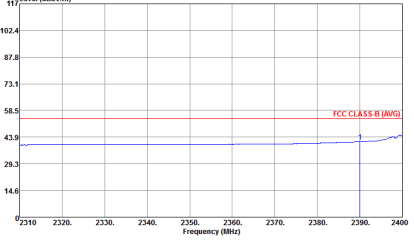

WIFI	2.4GHz 2400~2483.5MHz Band Edge @ 3m	
ANT	802.11b CH06 2437MHz - L	
1+2	Horizontal	Vertical
Peak	 <p>Site : 03CH11-HY Condition : FCC CLASS-B 3m HORN 9120D-HF HORIZONTAL Detector : Peak Project : 631828 Mode : IO</p>	 <p>Site : 03CH11-HY Condition : FCC CLASS-B 3m HORN 9120D-HF VERTICAL Detector : Peak Project : 631828 Mode : IO</p>
Avg.	 <p>Site : 03CH11-HY Condition : FCC CLASS-B (AVG) 3m HORN 9120D-HF HORIZONTAL Detector : Peak Project : 631828 Mode : IO</p>	 <p>Site : 03CH11-HY Condition : FCC CLASS-B (AVG) 3m HORN 9120D-HF VERTICAL Detector : Peak Project : 631828 Mode : IO</p>

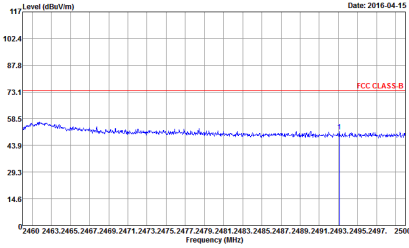
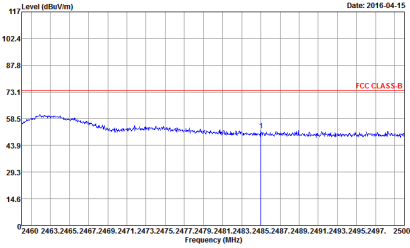
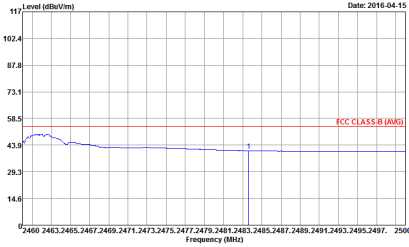
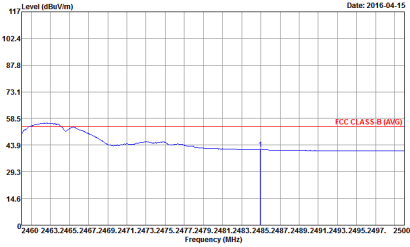

WIFI	2.4GHz 2400~2483.5MHz Band Edge @ 3m	
ANT	802.11b CH06 2437MHz - R	
1+2	Horizontal	Vertical
Peak	 <p>Site : 03CH11-HY Condition : FCC CLASS-B 3m HORN 9120D-HF HORIZONTAL RBW:1000.000KHz VBW:3000.000KHz SWT:Auto Detector : Peak Project : 631828 Mode : IO</p>	 <p>Site : 03CH11-HY Condition : FCC CLASS-B 3m HORN 9120D-HF VERTICAL RBW:1000.000KHz VBW:3000.000KHz SWT:Auto Detector : Peak Project : 631828 Mode : IO</p>
Avg.	 <p>Site : 03CH11-HY Condition : FCC CLASS-B (AVG) 3m HORN 9120D-HF HORIZONTAL RBW:1000.000KHz VBW:0.010KHz SWT:Auto Detector : Peak Project : 631828 Mode : IO</p>	 <p>Site : 03CH11-HY Condition : FCC CLASS-B (AVG) 3m HORN 9120D-HF VERTICAL RBW:1000.000KHz VBW:0.010KHz SWT:Auto Detector : Peak Project : 631828 Mode : IO</p>

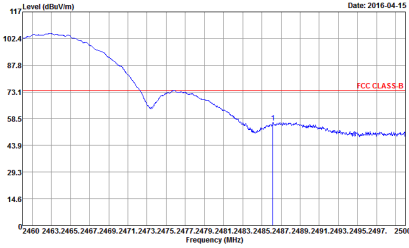
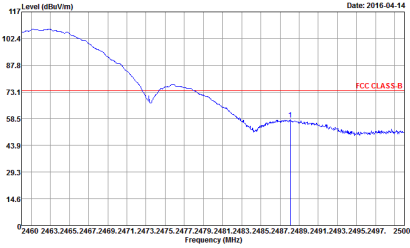
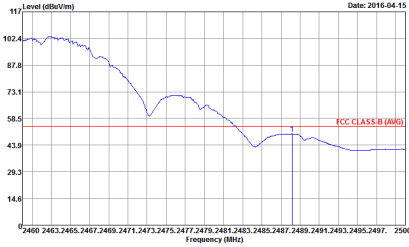
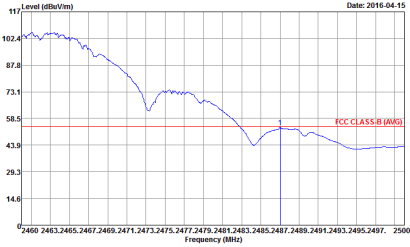

WIFI	2.4GHz 2400~2483.5MHz Band Edge @ 3m	
ANT	802.11b CH11 2462MHz	
1+2	Horizontal	Vertical
Peak	 <p>Date: 2016-04-15</p> <p>Site : 03CH11-HY Condition : FCC CLASS-B 3m HORN 9120D-HF HORIZONTAL : RBW:1000.000KHz VBW:3000.000KHz SWT:Auto Detector : Peak Project : 631828 Mode : 11 Power : 18</p>	 <p>Date: 2016-04-14</p> <p>Site : 03CH11-HY Condition : FCC CLASS-B 3m HORN 9120D-HF VERTICAL : RBW:1000.000KHz VBW:3000.000KHz SWT:Auto Detector : Peak Project : 631828 Mode : 11 Power : 18</p>
Avg.	 <p>Date: 2016-04-15</p> <p>Site : 03CH11-HY Condition : FCC CLASS-B (AVG) 3m HORN 9120D-HF HORIZONTAL : RBW:1000.000KHz VBW:0.010KHz SWT:Auto Detector : Peak Project : 631828 Mode : 11 Power : 18</p>	 <p>Date: 2016-04-15</p> <p>Site : 03CH11-HY Condition : FCC CLASS-B (AVG) 3m HORN 9120D-HF VERTICAL : RBW:1000.000KHz VBW:0.010KHz SWT:Auto Detector : Peak Project : 631828 Mode : 11 Power : 18</p>

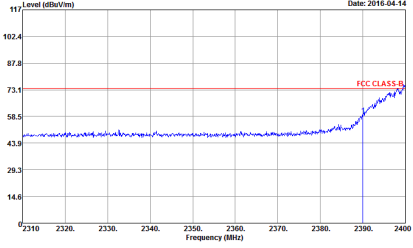
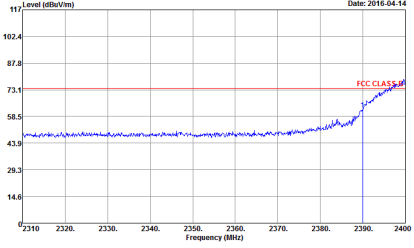
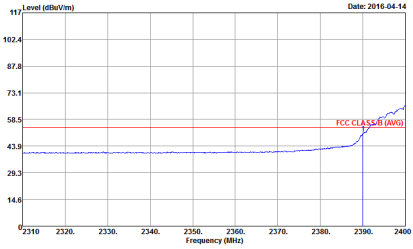
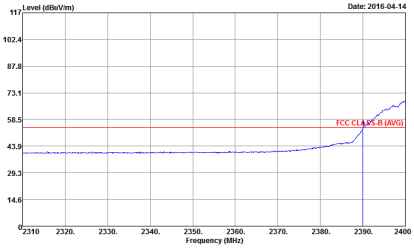

2.4GHz 2400~2483.5MHz
WIFI 802.11g (Band Edge @ 3m)

WIFI	2.4GHz 2400~2483.5MHz Band Edge @ 3m	
ANT	802.11g CH01 2412MHz	
1+2	Horizontal	Vertical
Peak	 <p>Site : 03CH11-HY Condition : FCC CLASS-B 3m HORN 9120D-HF HORIZONTAL Detector : Peak Project : 631828 Mode : 12 Power : 15</p>	 <p>Site : 03CH11-HY Condition : FCC CLASS-B 3m HORN 9120D-HF VERTICAL Detector : Peak Project : 631828 Mode : 12 Power : 15</p>
Avg.	 <p>Site : 03CH11-HY Condition : FCC CLASS-B (AVG) 3m HORN 9120D-HF HORIZONTAL Detector : Peak Project : 631828 Mode : 12 Power : 15</p>	 <p>Site : 03CH11-HY Condition : FCC CLASS-B (AVG) 3m HORN 9120D-HF VERTICAL Detector : Peak Project : 631828 Mode : 12 Power : 15</p>

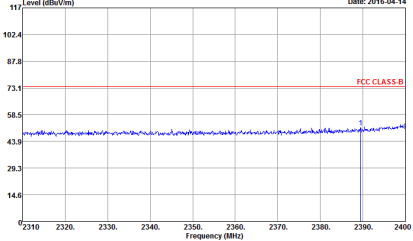
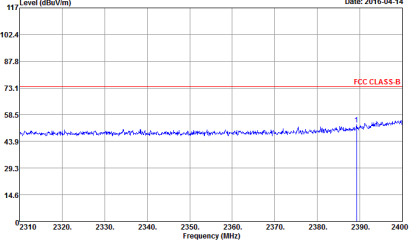
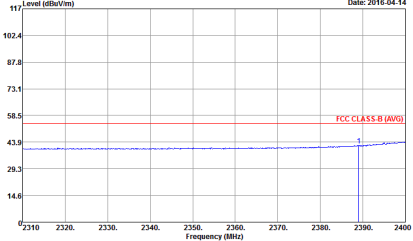
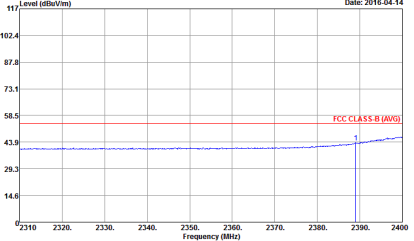

WIFI	2.4GHz 2400~2483.5MHz Band Edge @ 3m	
ANT	802.11g CH06 2437MHz - L	
1+2	Horizontal	Vertical
Peak	 <p>Site : 03CH11-HY Condition : FCC CLASS-B 3m HORN 9120D-HF HORIZONTAL Detector : Peak Project : 631828 Mode : 13</p>	 <p>Site : 03CH11-HY Condition : FCC CLASS-B 3m HORN 9120D-HF VERTICAL Detector : Peak Project : 631828 Mode : 13</p>
Avg.	 <p>Site : 03CH11-HY Condition : FCC CLASS-B (AVG) 3m HORN 9120D-HF HORIZONTAL Detector : Peak Project : 631828 Mode : 13</p>	 <p>Site : 03CH11-HY Condition : FCC CLASS-B (AVG) 3m HORN 9120D-HF VERTICAL Detector : Peak Project : 631828 Mode : 13</p>

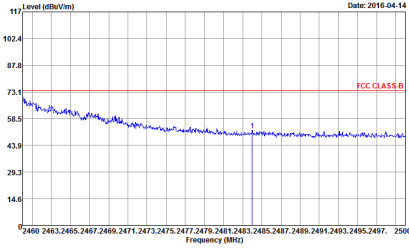
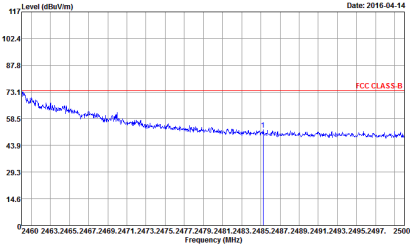
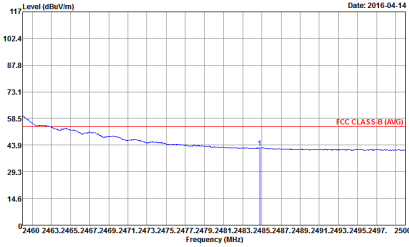
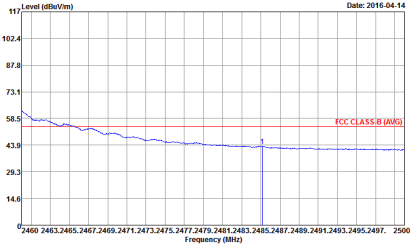

WIFI	2.4GHz 2400~2483.5MHz Band Edge @ 3m	
ANT	802.11g CH06 2437MHz - R	
1+2	Horizontal	Vertical
Peak	 <p>Site : 03CH11-HY Condition : FCC CLASS-B 3m HORN 9120D-HF HORIZONTAL RBW:1000.000KHz VBW:3000.000KHz SWT:Auto Detector : Peak Project : 631828 Mode : 13</p>	 <p>Site : 03CH11-HY Condition : FCC CLASS-B 3m HORN 9120D-HF VERTICAL RBW:1000.000KHz VBW:3000.000KHz SWT:Auto Detector : Peak Project : 631828 Mode : 13</p>
Avg.	 <p>Site : 03CH11-HY Condition : FCC CLASS-B (AVG) 3m HORN 9120D-HF HORIZONTAL RBW:1000.000KHz VBW:1.000KHz SWT:Auto Detector : Peak Project : 631828 Mode : 13</p>	 <p>Site : 03CH11-HY Condition : FCC CLASS-B (AVG) 3m HORN 9120D-HF VERTICAL RBW:1000.000KHz VBW:1.000KHz SWT:Auto Detector : Peak Project : 631828 Mode : 13</p>

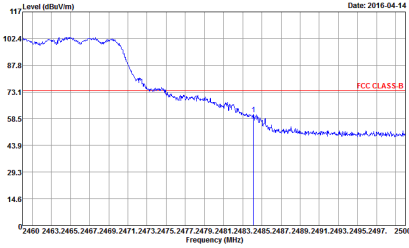
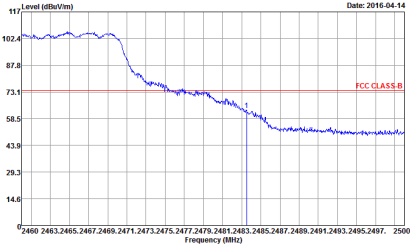
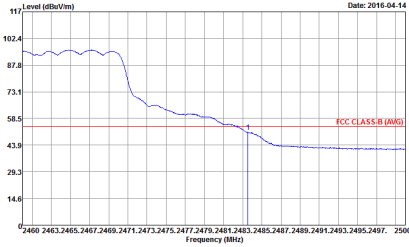
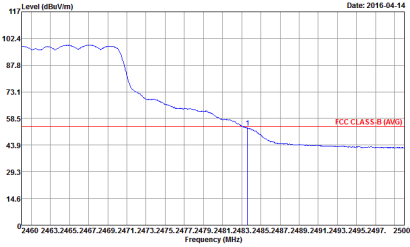

WIFI	2.4GHz 2400~2483.5MHz Band Edge @ 3m	
ANT	802.11g CH11 2462MHz	
1+2	Horizontal	Vertical
Peak	 <p>Site : 03CH11-HY Condition : FCC CLASS-B 3m HORN 9120D-HF HORIZONTAL : RBW:1000.000KHz VBW:3000.000KHz SWT:Auto Detector : Peak Project : 631828 Mode : 14 Power : 13.5</p>	 <p>Site : 03CH11-HY Condition : FCC CLASS-B 3m HORN 9120D-HF VERTICAL : RBW:1000.000KHz VBW:3000.000KHz SWT:Auto Detector : Peak Project : 631828 Mode : 14 Power : 13.5</p>
Avg.	 <p>Site : 03CH11-HY Condition : FCC CLASS-B (AVG) 3m HORN 9120D-HF HORIZONTAL : RBW:1000.000KHz VBW:1.000KHz SWT:Auto Detector : Peak Project : 631828 Mode : 14 Power : 13.5</p>	 <p>Site : 03CH11-HY Condition : FCC CLASS-B (AVG) 3m HORN 9120D-HF VERTICAL : RBW:1000.000KHz VBW:1.000KHz SWT:Auto Detector : Peak Project : 631828 Mode : 14 Power : 13.5</p>

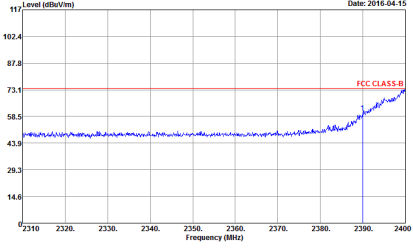
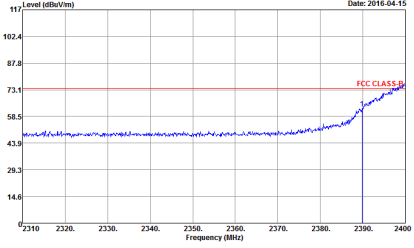
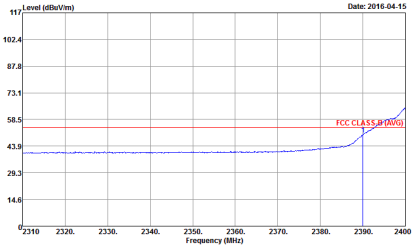
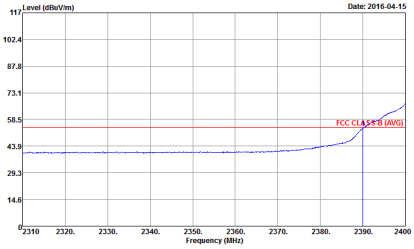

2.4GHz 2400~2483.5MHz
WIFI 802.11n HT20 (Band Edge @ 3m)

WIFI	2.4GHz 2400~2483.5MHz Band Edge @ 3m	
ANT	802.11n HT20 CH01 2412MHz	
1+2	Horizontal	Vertical
Peak	 <p>Site : 03CH11-HY Condition : FCC CLASS-B 3m HORN 9120D-HF HORIZONTAL Detector : Peak Project : 631828 Mode : 15 Power : 14.5</p>	 <p>Site : 03CH11-HY Condition : FCC CLASS-B 3m HORN 9120D-HF VERTICAL Detector : Peak Project : 631828 Mode : 15 Power : 14.5</p>
Avg.	 <p>Site : 03CH11-HY Condition : FCC CLASS-B (AVG) 3m HORN 9120D-HF HORIZONTAL Detector : Peak Project : 631828 Mode : 15 Power : 14.5</p>	 <p>Site : 03CH11-HY Condition : FCC CLASS-B (AVG) 3m HORN 9120D-HF VERTICAL Detector : Peak Project : 631828 Mode : 15 Power : 14.5</p>

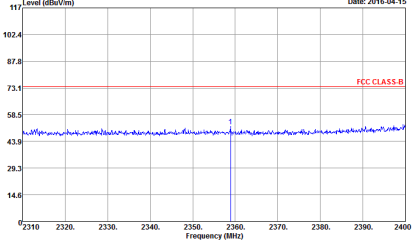
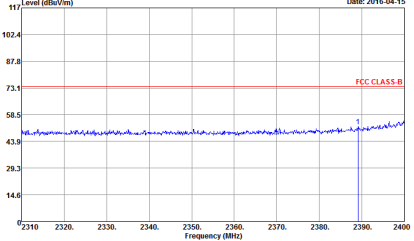
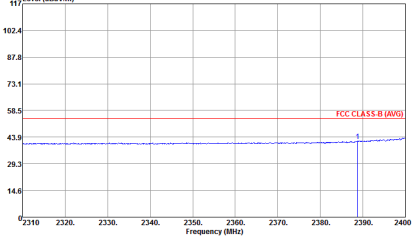
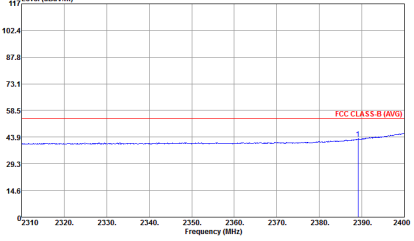

WIFI	2.4GHz 2400~2483.5MHz Band Edge @ 3m	
ANT	802.11n HT20 CH06 2437MHz - L	
1+2	Horizontal	Vertical
Peak	 <p>Date: 2016-04-15</p> <p>Site : 03CH11-HY Condition : FCC CLASS-B 3m HORN 9120D-HF HORIZONTAL RBW:1000.000KHz VBW:3000.000KHz SWT:Auto Detector : Peak Project : 631828 Mode : 16</p>	 <p>Date: 2016-04-15</p> <p>Site : 03CH11-HY Condition : FCC CLASS-B 3m HORN 9120D-HF VERTICAL RBW:1000.000KHz VBW:3000.000KHz SWT:Auto Detector : Peak Project : 631828 Mode : 16</p>
Avg.	 <p>Date: 2016-04-15</p> <p>Site : 03CH11-HY Condition : FCC CLASS-B (AVG) 3m HORN 9120D-HF HORIZONTAL RBW:1000.000KHz VBW:1.000KHz SWT:Auto Detector : Peak Project : 631828 Mode : 16</p>	 <p>Date: 2016-04-15</p> <p>Site : 03CH11-HY Condition : FCC CLASS-B (AVG) 3m HORN 9120D-HF VERTICAL RBW:1000.000KHz VBW:1.000KHz SWT:Auto Detector : Peak Project : 631828 Mode : 16</p>

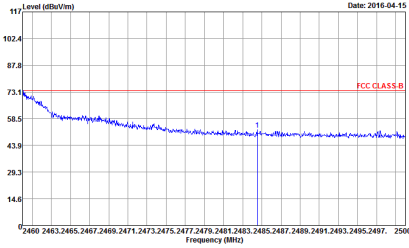
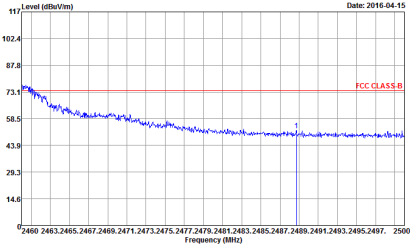
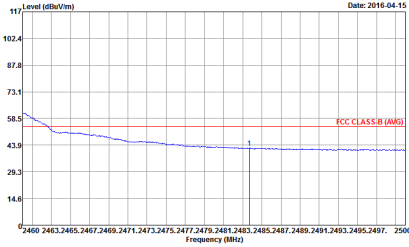
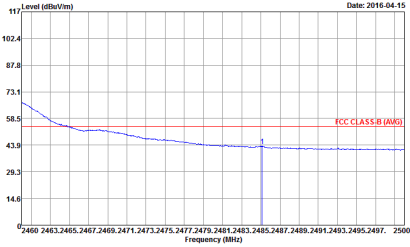

WIFI	2.4GHz 2400~2483.5MHz Band Edge @ 3m	
ANT	802.11n HT20 CH06 2437MHz - R	
1+2	Horizontal	Vertical
Peak	 <p>Date: 2016-04-15</p> <p>Level (dBuV/m)</p> <p>Frequency (MHz)</p> <p>Site : 03CH11-HY Condition : FCC CLASS-B 3m HORN 9120D-HF HORIZONTAL RBW:1000.000KHz VBW:3000.000KHz SWT:Auto Detector : Peak Project : 631828 Mode : 16</p>	 <p>Date: 2016-04-15</p> <p>Level (dBuV/m)</p> <p>Frequency (MHz)</p> <p>Site : 03CH11-HY Condition : FCC CLASS-B 3m HORN 9120D-HF VERTICAL RBW:1000.000KHz VBW:3000.000KHz SWT:Auto Detector : Peak Project : 631828 Mode : 16</p>
Avg.	 <p>Date: 2016-04-15</p> <p>Level (dBuV/m)</p> <p>Frequency (MHz)</p> <p>Site : 03CH11-HY Condition : FCC CLASS-B (AVG) 3m HORN 9120D-HF HORIZONTAL RBW:1000.000KHz VBW:1.000KHz SWT:Auto Detector : Peak Project : 631828 Mode : 16</p>	 <p>Date: 2016-04-15</p> <p>Level (dBuV/m)</p> <p>Frequency (MHz)</p> <p>Site : 03CH11-HY Condition : FCC CLASS-B (AVG) 3m HORN 9120D-HF VERTICAL RBW:1000.000KHz VBW:1.000KHz SWT:Auto Detector : Peak Project : 631828 Mode : 16</p>

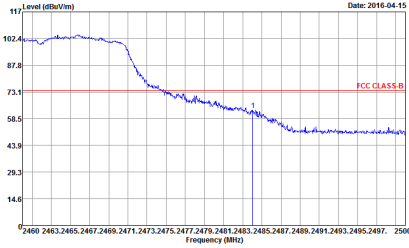
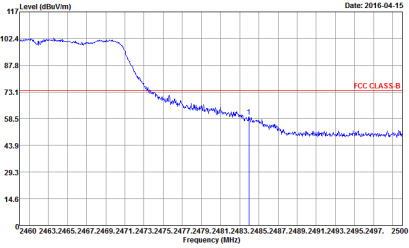
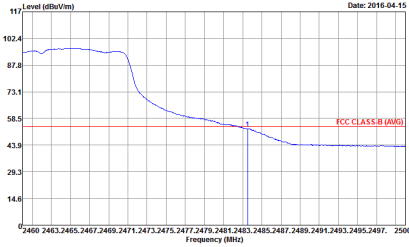
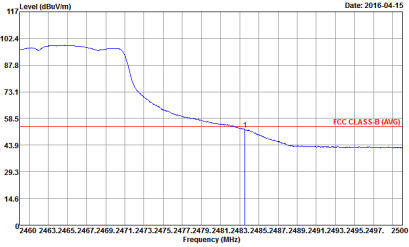

WIFI	2.4GHz 2400~2483.5MHz Band Edge @ 3m	
ANT	802.11n HT20 CH11 2462MHz	
1+2	Horizontal	Vertical
Peak	 <p>Site : 03CH11-HY Condition : FCC CLASS-B 3m HORN 9120D-HF HORIZONTAL : RBW:1000.000KHz VBW:3000.000KHz SWT:Auto Detector : Peak Project : 631828 Mode : 17 Setting : 13</p>	 <p>Site : 03CH11-HY Condition : FCC CLASS-B 3m HORN 9120D-HF VERTICAL : RBW:1000.000KHz VBW:3000.000KHz SWT:Auto Detector : Peak Project : 631828 Mode : 17 Setting : 13</p>
Avg.	 <p>Site : 03CH11-HY Condition : FCC CLASS-B (AVG) 3m HORN 9120D-HF HORIZONTAL : RBW:1000.000KHz VBW:1.000KHz SWT:Auto Detector : Peak Project : 631828 Mode : 17 Setting : 13</p>	 <p>Site : 03CH11-HY Condition : FCC CLASS-B (AVG) 3m HORN 9120D-HF VERTICAL : RBW:1000.000KHz VBW:1.000KHz SWT:Auto Detector : Peak Project : 631828 Mode : 17 Setting : 13</p>



2.4GHz 2400~2483.5MHz

WIFI 802.11ac VHT20 (Band Edge @ 3m)

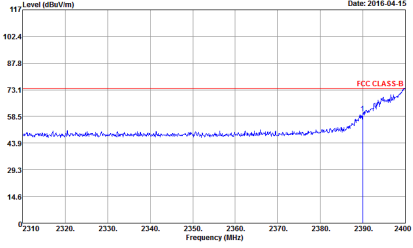
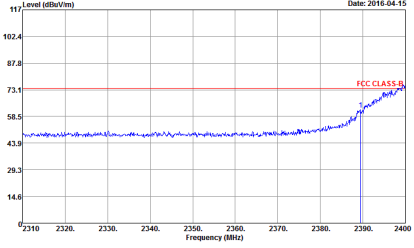
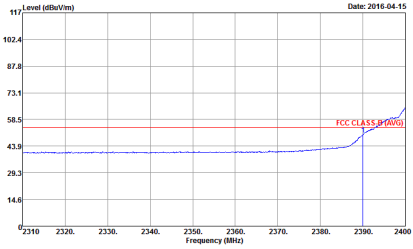
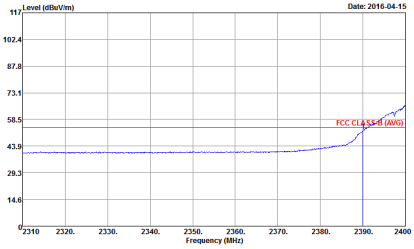
WIFI	2.4GHz 2400~2483.5MHz Band Edge @ 3m	
ANT	802.11ac VHT20 CH01 2412MHz	
1+2	Horizontal	Vertical
Peak	 <p>Site : 03CH11-HY Condition : FCC CLASS-B 3m HORN 9120D-HF HORIZONTAL RBW:1000.000KHz VBW:3000.000KHz SWT:Auto Detector : Peak Project : 631828 Mode : 18 Setting : 14.5</p>	 <p>Site : 03CH11-HY Condition : FCC CLASS-B 3m HORN 9120D-HF VERTICAL RBW:1000.000KHz VBW:3000.000KHz SWT:Auto Detector : Peak Project : 631828 Mode : 18 Setting : 14.5</p>
Avg.	 <p>Site : 03CH11-HY Condition : FCC CLASS-B (AVG) 3m HORN 9120D-HF HORIZONTAL RBW:1000.000KHz VBW:1.000KHz SWT:Auto Detector : Peak Project : 631828 Mode : 18 Setting : 14.5</p>	 <p>Site : 03CH11-HY Condition : FCC CLASS-B (AVG) 3m HORN 9120D-HF VERTICAL RBW:1000.000KHz VBW:1.000KHz SWT:Auto Detector : Peak Project : 631828 Mode : 18 Setting : 14.5</p>

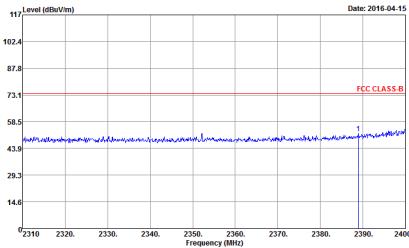
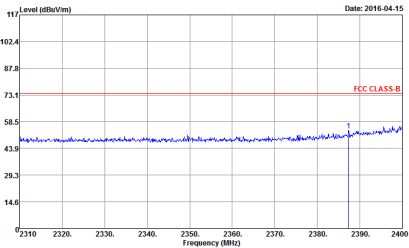
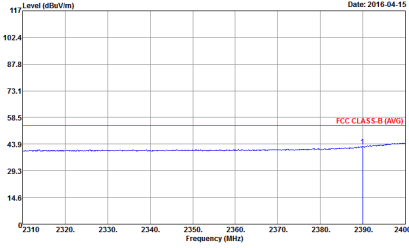
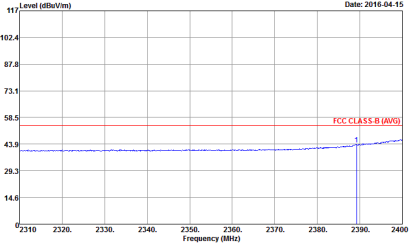

WIFI	2.4GHz 2400~2483.5MHz Band Edge @ 3m	
ANT	802.11ac VHT20 CH06 2437MHz - L	
1+2	Horizontal	Vertical
Peak	 <p>Site : 03CH11-HY Condition : FCC CLASS-B 3m HORN 9120D-HF HORIZONTAL RBW:1000.000KHz VBW:3000.000KHz SWT:Auto Detector : Peak Project : 631828 Mode : 19</p>	 <p>Site : 03CH11-HY Condition : FCC CLASS-B 3m HORN 9120D-HF VERTICAL RBW:1000.000KHz VBW:3000.000KHz SWT:Auto Detector : Peak Project : 631828 Mode : 19</p>
Avg.	 <p>Site : 03CH11-HY Condition : FCC CLASS-B (AVG) 3m HORN 9120D-HF HORIZONTAL RBW:1000.000KHz VBW:1.000KHz SWT:Auto Detector : Peak Project : 631828 Mode : 19</p>	 <p>Site : 03CH11-HY Condition : FCC CLASS-B (AVG) 3m HORN 9120D-HF VERTICAL RBW:1000.000KHz VBW:1.000KHz SWT:Auto Detector : Peak Project : 631828 Mode : 19</p>

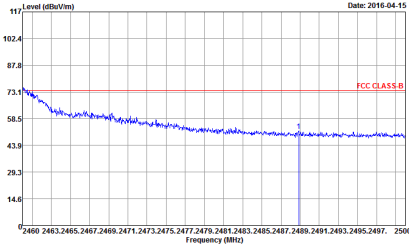
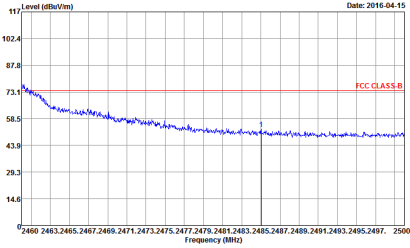
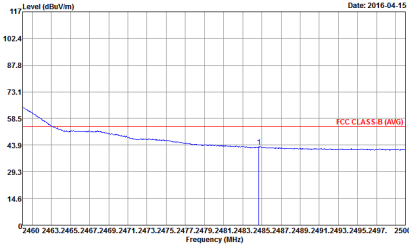
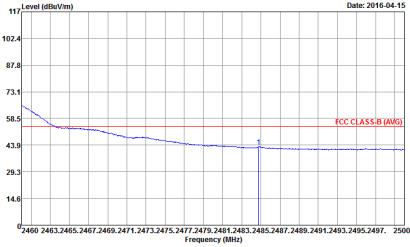

WIFI	2.4GHz 2400~2483.5MHz Band Edge @ 3m	
ANT	802.11ac VH20 CH06 2437MHz - R	
1+2	Horizontal	Vertical
Peak	 <p>Date: 2016-04-15</p> <p>Site : 03CH11-HY Condition : FCC CLASS-B 3m HORN 9120D-HF HORIZONTAL : RBW:1000.000KHz VBW:3000.000KHz SWT:Auto Detector : Peak Project : 631828 Mode : 19</p>	 <p>Date: 2016-04-15</p> <p>Site : 03CH11-HY Condition : FCC CLASS-B 3m HORN 9120D-HF VERTICAL : RBW:1000.000KHz VBW:3000.000KHz SWT:Auto Detector : Peak Project : 631828 Mode : 19</p>
Avg.	 <p>Date: 2016-04-15</p> <p>Site : 03CH11-HY Condition : FCC CLASS-B (AVG) 3m HORN 9120D-HF HORIZONTAL : RBW:1000.000KHz VBW:1.000KHz SWT:Auto Detector : Peak Project : 631828 Mode : 19</p>	 <p>Date: 2016-04-15</p> <p>Site : 03CH11-HY Condition : FCC CLASS-B (AVG) 3m HORN 9120D-HF VERTICAL : RBW:1000.000KHz VBW:1.000KHz SWT:Auto Detector : Peak Project : 631828 Mode : 19</p>

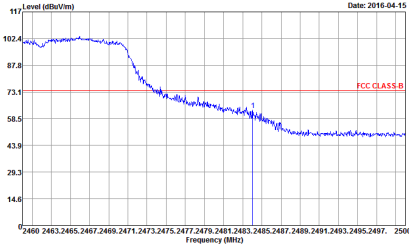
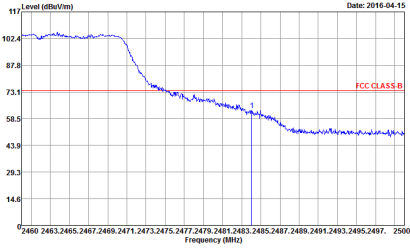
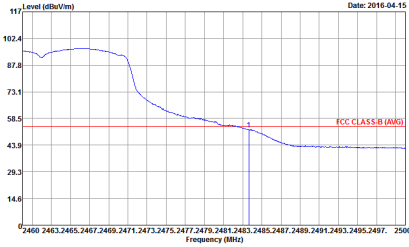
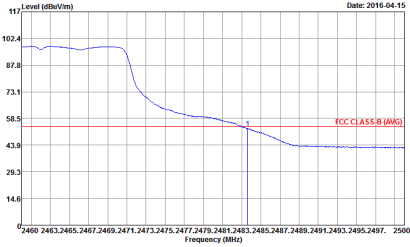

WIFI	2.4GHz 2400~2483.5MHz Band Edge @ 3m	
ANT	802.11ac VH20 CH11 2462MHz	
1+2	Horizontal	Vertical
Peak	 <p>Site : 03CH11-HY Condition : FCC CLASS-B 3m HORN 9120D-HF HORIZONTAL : RBW:1000.000KHz VBW:3000.000KHz SWT:Auto Detector : Peak Project : 631828 Mode : 20 Setting : 13</p>	 <p>Site : 03CH11-HY Condition : FCC CLASS-B 3m HORN 9120D-HF VERTICAL : RBW:1000.000KHz VBW:3000.000KHz SWT:Auto Detector : Peak Project : 631828 Mode : 20 Setting : 13</p>
Avg.	 <p>Site : 03CH11-HY Condition : FCC CLASS-B (AVG) 3m HORN 9120D-HF HORIZONTAL : RBW:1000.000KHz VBW:1.000KHz SWT:Auto Detector : Peak Project : 631828 Mode : 20 Setting : 13</p>	 <p>Site : 03CH11-HY Condition : FCC CLASS-B (AVG) 3m HORN 9120D-HF VERTICAL : RBW:1000.000KHz VBW:1.000KHz SWT:Auto Detector : Peak Project : 631828 Mode : 20 Setting : 13</p>



2.4GHz 2400~2483.5MHz
WIFI 802.11b (Harmonic @ 3m)

Table with 2 columns: Horizontal and Vertical. Each column contains a graph of Level (dBuV/m) vs Frequency (MHz) and associated test parameters like Site, Condition, Detector, Project, and Mode.

Peak
Avg.

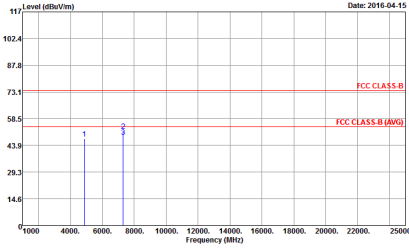
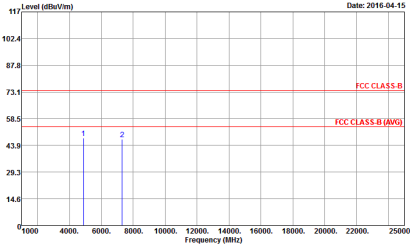

WIFI	2.4GHz 2400~2483.5MHz Harmonic @ 3m	
ANT	802.11b CH06 2437MHz	
1+2	Horizontal	Vertical
<p>Peak</p> <p>Avg.</p>	 <p>Site : 03CH11-HY Condition : FCC CLASS-B 3m 9170 SHF HORM_150809 HORIZONTAL Detector : Peak Project : 631828 Mode : 10</p>	 <p>Site : 03CH11-HY Condition : FCC CLASS-B 3m 9170 SHF HORM_150809 VERTICAL Detector : Peak Project : 631828 Mode : 10</p>

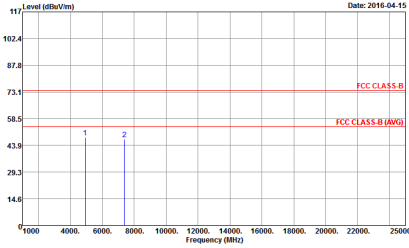
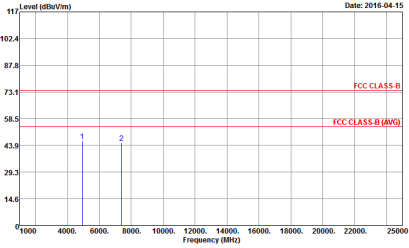

WIFI	2.4GHz 2400~2483.5MHz Harmonic @ 3m	
ANT	802.11b CH11 2462MHz	
1+2	Horizontal	Vertical
<p>Peak</p> <p>Avg.</p>	 <p>Site : 03CH11-HY Condition : FCC CLASS-B 3m 9170 SHF HORM_150809 HORIZONTAL Detector : Peak Project : 631828 Mode : 11</p>	 <p>Site : 03CH11-HY Condition : FCC CLASS-B 3m 9170 SHF HORM_150809 VERTICAL Detector : Peak Project : 631828 Mode : 11</p>



2.4GHz 2400~2483.5MHz
 WIFI 802.11g (Harmonic @ 3m)

WIFI	2.4GHz 2400~2483.5MHz Harmonic @ 3m	
ANT	802.11g CH01 2412MHz	
1+2	Horizontal	Vertical
Peak Avg.	<p>Site : 03CH11-HY Condition : FCC CLASS-B 3m 9170 SHF HORM_150809 HORIZONTAL Detector : Peak Project : 631828 Mode : 12</p>	<p>Site : 03CH11-HY Condition : FCC CLASS-B 3m 9170 SHF HORM_150809 VERTICAL Detector : Peak Project : 631828 Mode : 12</p>

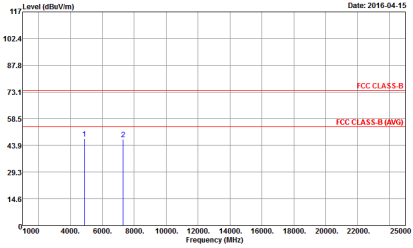
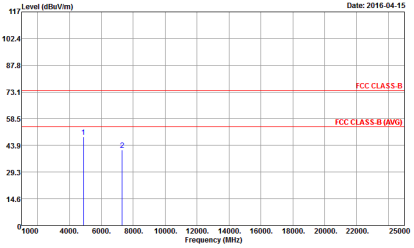

WIFI	2.4GHz 2400~2483.5MHz Harmonic @ 3m	
ANT	802.11g CH06 2437MHz	
1+2	Horizontal	Vertical
<p>Peak</p> <p>Avg.</p>	 <p>Site : 03CH11-HY Condition : FCC CLASS-B 3m 9170 SHF HORM_150809 HORIZONTAL Detector : Peak Project : 631828 Mode : 13</p>	 <p>Site : 03CH11-HY Condition : FCC CLASS-B 3m 9170 SHF HORM_150809 VERTICAL Detector : Peak Project : 631828 Mode : 13</p>

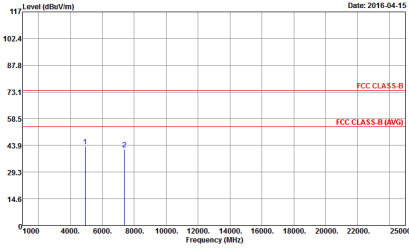
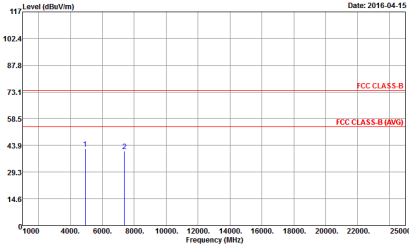

WIFI	2.4GHz 2400~2483.5MHz Harmonic @ 3m	
ANT	802.11g CH11 2462MHz	
1+2	Horizontal	Vertical
<p>Peak</p> <p>Avg.</p>	 <p>Date: 2016-04-15</p> <p>Site : 03CH11-HY Condition : FCC CLASS-B 3m 9170 SHF HORM_150809 HORIZONTAL Detector : Peak Project : 631828 Mode : 14</p>	 <p>Date: 2016-04-15</p> <p>Site : 03CH11-HY Condition : FCC CLASS-B 3m 9170 SHF HORM_150809 VERTICAL Detector : Peak Project : 631828 Mode : 14</p>



2.4GHz 2400~2483.5MHz
WIFI 802.11n HT20 (Harmonic @ 3m)

WIFI	2.4GHz 2400~2483.5MHz Harmonic @ 3m	
ANT	802.11n HT20 CH01 2412MHz	
1+2	Horizontal	Vertical
Peak Avg.	<p style="font-size: small;">Date: 2016-04-15</p> <p style="font-size: x-small;">Site : 03CH11-HY Condition : FCC CLASS-B 3m 9170 SHF HORM_150809 HORIZONTAL Detector : Peak Project : 631828 Mode : 15</p>	<p style="font-size: small;">Date: 2016-04-15</p> <p style="font-size: x-small;">Site : 03CH11-HY Condition : FCC CLASS-B 3m 9170 SHF HORM_150809 VERTICAL Detector : Peak Project : 631828 Mode : 15</p>



WIFI	2.4GHz 2400~2483.5MHz Harmonic @ 3m	
ANT	802.11n HT20 CH06 2437MHz	
1+2	Horizontal	Vertical
Peak Avg.	<p>Site : 03CH11-HY Condition : FCC CLASS-B 3m 9170 SHF HORM_150809 HORIZONTAL Detector : Peak Project : 631828 Mode : 16</p>	<p>Site : 03CH11-HY Condition : FCC CLASS-B 3m 9170 SHF HORM_150809 VERTICAL Detector : Peak Project : 631828 Mode : 16</p>

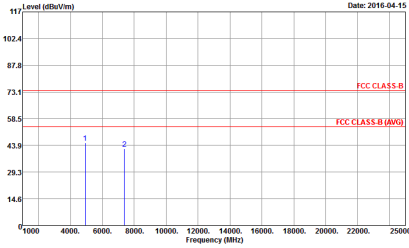
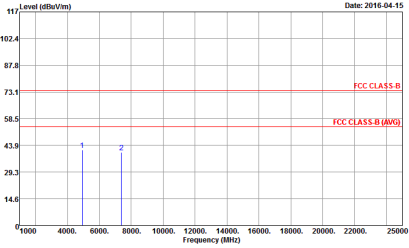

WIFI	2.4GHz 2400~2483.5MHz Harmonic @ 3m	
ANT	802.11n HT20 CH11 2462MHz	
1+2	Horizontal	Vertical
<p>Peak</p> <p>Avg.</p>	 <p>Site : 03CH11-HY Condition : FCC CLASS-B 3m 9170 SHF HORM_150809 HORIZONTAL Detector : Peak Project : 631828 Mode : 17</p>	 <p>Site : 03CH11-HY Condition : FCC CLASS-B 3m 9170 SHF HORM_150809 VERTICAL Detector : Peak Project : 631828 Mode : 17</p>



2.4GHz 2400~2483.5MHz
WIFI 802.11ac VHT20 (Harmonic @ 3m)

WIFI	2.4GHz 2400~2483.5MHz Harmonic @ 3m	
ANT	802.11ac VHT20 CH01 2412MHz	
1+2	Horizontal	Vertical
Peak Avg.	<p>Site : 03CH11-HY Condition : FCC CLASS-B 3m 9170 SHF HORM_150809 HORIZONTAL Detector : Peak Project : 631828 Mode : 18</p>	<p>Site : 03CH11-HY Condition : FCC CLASS-B 3m 9170 SHF HORM_150809 VERTICAL Detector : Peak Project : 631828 Mode : 18</p>

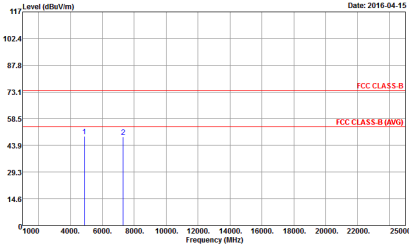
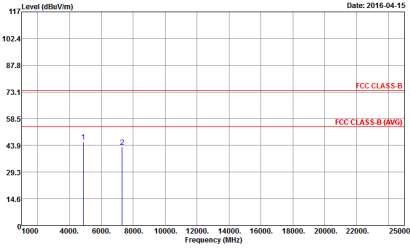

WIFI	2.4GHz 2400~2483.5MHz Harmonic @ 3m	
ANT	802.11ac VHT20 CH06 2437MHz	
1+2	Horizontal	Vertical
<p>Peak</p> <p>Avg.</p>	 <p>Site : 03CH11-HY Condition : FCC CLASS-B 3m 9170 SHF HORM_150809 HORIZONTAL Detector : Peak Project : 631828 Mode : 19</p>	 <p>Site : 03CH11-HY Condition : FCC CLASS-B 3m 9170 SHF HORM_150809 VERTICAL Detector : Peak Project : 631828 Mode : 19</p>

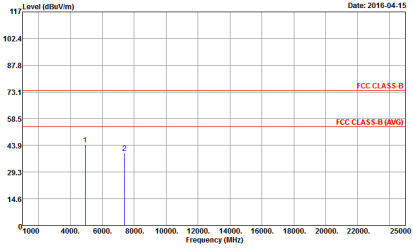
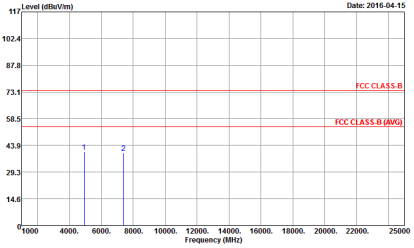

WIFI	2.4GHz 2400~2483.5MHz Harmonic @ 3m	
ANT	802.11ac VHT20 CH11 2462MHz	
1+2	Horizontal	Vertical
<p>Peak</p> <p>Avg.</p>	 <p>Site : 03CH11-HY Condition : FCC CLASS-B 3m 9170 SHF HORM_150809 HORIZONTAL Detector : Peak Project : 631828 Mode : 20</p>	 <p>Site : 03CH11-HY Condition : FCC CLASS-B 3m 9170 SHF HORM_150809 VERTICAL Detector : Peak Project : 631828 Mode : 20</p>



Emission below 1GHz
2.4GHz WIFI 802.11b (LF)

WIFI	2.4GHz 2400~2483.5MHz	
ANT	802.11b LF	
1+2	Horizontal	Vertical
QP / Peak	<p>Site : 03CH11-HY Condition : FCC CLASS-B 3m 81-LOG 6111D-LF_ETC HORIZONTAL Detector : Peak Project : 631828 Mode : Z1</p>	<p>Site : 03CH11-HY Condition : FCC CLASS-B 3m 81-LOG 6111D-LF_ETC VERTICAL Detector : Peak Project : 631828 Mode : Z1</p>



Appendix D. Duty Cycle Plots

Antenna	Band	Duty Cycle(%)	T(us)	1/T(kHz)	VBW Setting
1+2	2.4GHz 802.11b for Ant 1	99.04	-	-	10Hz
1+2	2.4GHz 802.11b for Ant 2	99.05	-	-	10Hz
1+2	2.4GHz 802.11g for Ant 1	94.5	2060	0.49	1kHz
1+2	2.4GHz 802.11g for Ant 2	94.5	2060	0.49	1kHz
1+2	2.4GHz 802.11n HT20 for Ant 1	94.12	1920	0.52	1kHz
1+2	2.4GHz 802.11n HT20 for Ant 2	93.14	1900	0.53	1kHz
1+2	2.4GHz 802.11ac VHT20 for Ant 1	94.12	1920	0.52	1kHz
1+2	2.4GHz 802.11ac VHT20 for Ant 2	94.18	1940	0.52	1kHz



MIMO <Ant. 1+2(1)>

802.11b

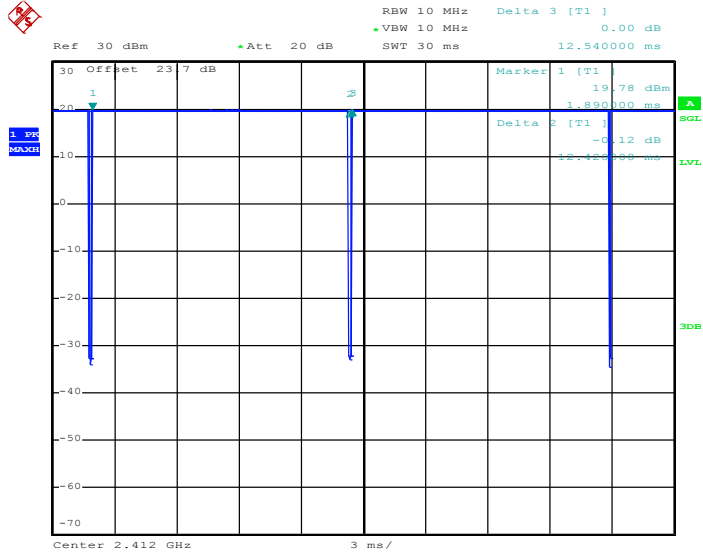

Date: 8.APR.2016 16:15:33

802.11g

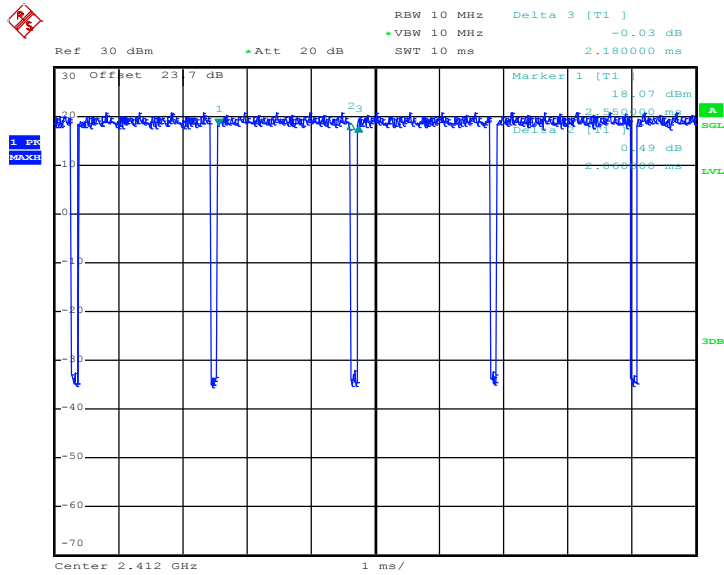

Date: 8.APR.2016 16:23:48



802.11n HT20

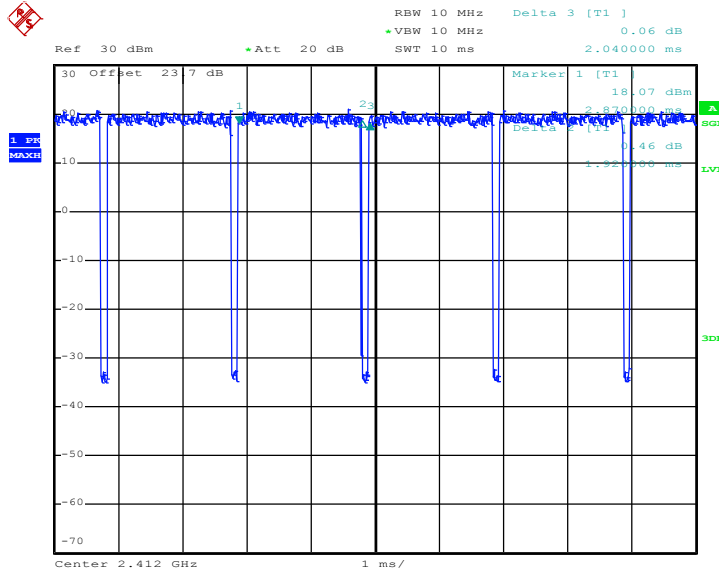

Date: 8.APR.2016 16:33:25

802.11ac VHT20

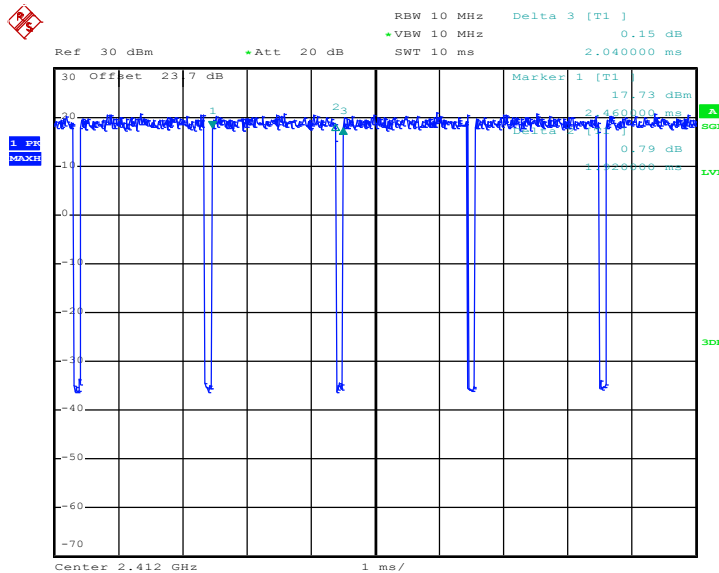

Date: 12.APR.2016 13:58:12



MIMO <Ant. 1+2(2)>

802.11b

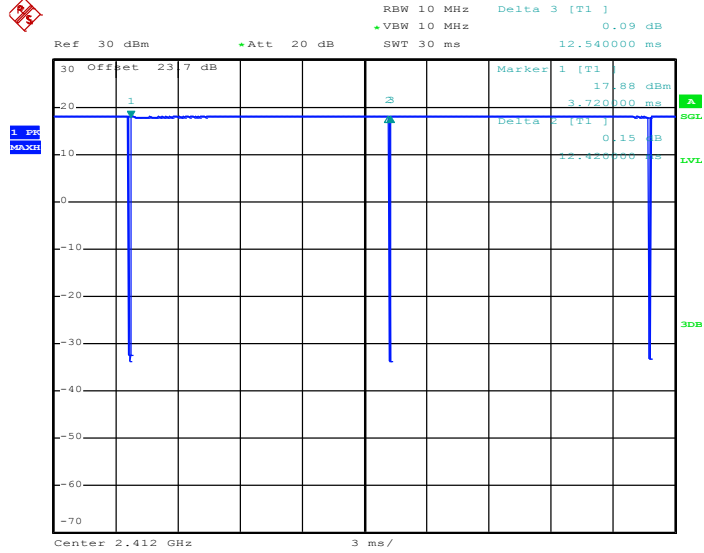

Date: 8.APR.2016 16:14:29

802.11g

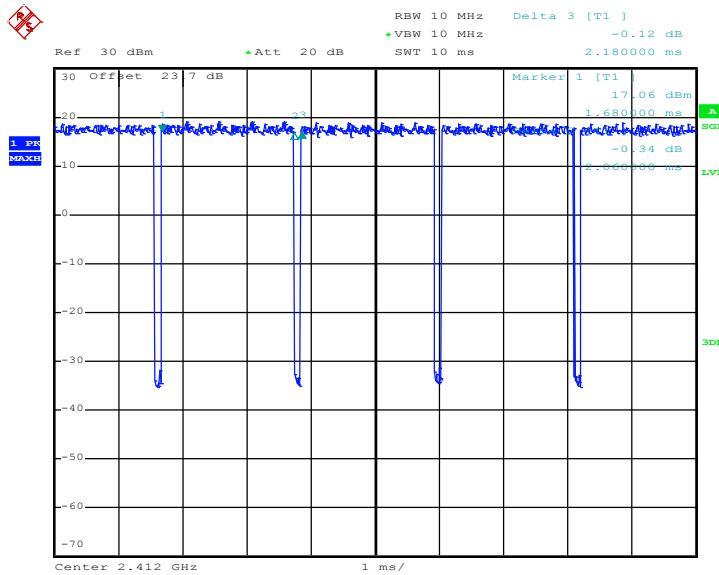

Date: 8.APR.2016 16:23:03



802.11n HT20

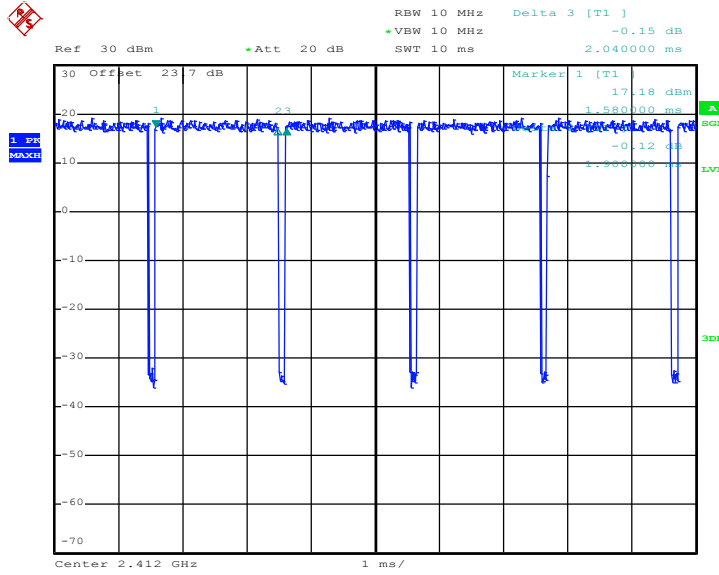

Date: 8.APR.2016 16:32:37

802.11ac VHT20

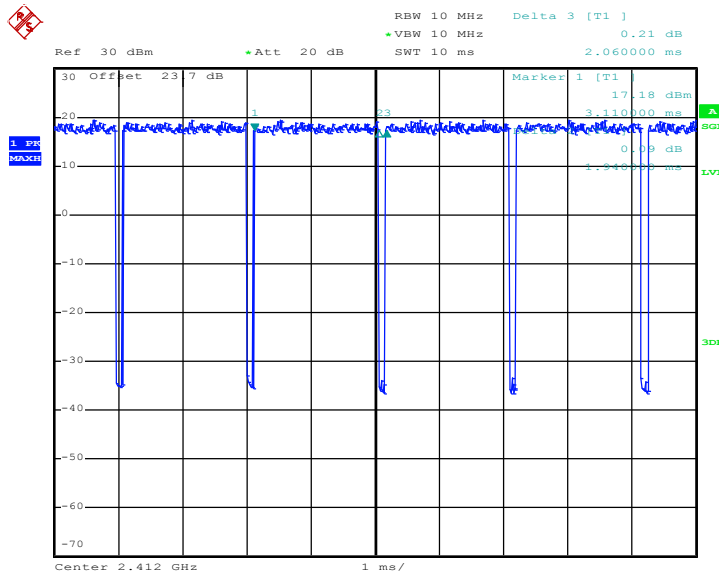

Date: 12.APR.2016 13:57:24