



# FCC RF Test Report

**APPLICANT** : Motorola Mobility, LLC  
**EQUIPMENT** : Mobile Cellular Phone  
**BRAND NAME** : Motorola  
**MODEL NAME** : 4247  
**FCC ID** : IHDT56QG1  
**STANDARD** : FCC 47 CFR Part 2, 22(H), 24(E), 27(L)  
**CLASSIFICATION** : PCS Licensed Transmitter Held to Ear (PCE)

The product was received on Apr. 20, 2015 and testing was completed on Jun. 15, 2015. We, SPORTON INTERNATIONAL INC., would like to declare that the tested sample has been evaluated in accordance with the test procedures given in ANSI / TIA / EIA-603-C-2004 and has been in compliance with the applicable technical standards.

The test results in this report apply exclusively to the tested model / sample. Without written approval of SPORTON INTERNATIONAL INC., the test report shall not be reproduced except in full.

Reviewed by: Joseph Lin / Supervisor

Approved by: Jones Tsai / Manager



## SPORTON INTERNATIONAL INC.

No. 52, Hwa Ya 1<sup>st</sup> Rd., Hwa Ya Technology Park, Kwei-Shan District, Tao Yuan City, Taiwan, R.O.C.



# TABLE OF CONTENTS

**REVISION HISTORY..... 3**

**SUMMARY OF TEST RESULT ..... 4**

**1 GENERAL DESCRIPTION ..... 5**

    1.1 Applicant..... 5

    1.2 Manufacturer ..... 5

    1.3 Product Feature of Equipment Under Test ..... 5

    1.4 Product Specification subjective to this standard ..... 6

    1.5 Modification of EUT ..... 6

    1.6 Maximum ERP/EIRP Power, Frequency Tolerance, and Emission Designator ..... 7

    1.7 Testing Location ..... 7

    1.8 Applicable Standards ..... 8

**2 TEST CONFIGURATION OF EQUIPMENT UNDER TEST ..... 9**

    2.1 Test Mode..... 9

    2.2 Connection Diagram of Test System ..... 11

    2.3 Support Unit used in test configuration ..... 11

    2.4 Measurement Results Explanation Example ..... 11

**3 TEST RESULT ..... 12**

    3.1 Conducted Output Power Measurement..... 12

    3.2 Peak-to-Average Ratio ..... 14

    3.3 Effective Radiated Power and Effective Isotropic Radiated Power Measurement ..... 22

    3.4 99% Occupied Bandwidth and 26dB Bandwidth Measurement..... 26

    3.5 Band Edge Measurement..... 37

    3.6 Conducted Spurious Emission Measurement ..... 41

    3.7 Field Strength of Spurious Radiation Measurement ..... 51

    3.8 Frequency Stability Measurement..... 62

**4 LIST OF MEASURING EQUIPMENT ..... 67**

**5 UNCERTAINTY OF EVALUATION ..... 68**

**APPENDIX A. ORIGINAL REPORT**





## SUMMARY OF TEST RESULT

Report Section	FCC Rule	Description	Limit	Result	Remark
3.1	§2.1046	Conducted Output Power	Reporting Only	PASS	-
3.2	§24.232(d)	Peak-to-Average Ratio	< 13 dB	PASS	-
3.3	§22.913(a)(2)	Effective Radiated Power	< 7 Watts	PASS	-
	§24.232(c)	Equivalent Isotropic Radiated Power	< 2 Watts	PASS	-
	§27.50(d)(4)	Equivalent Isotropic Radiated Power	< 1 Watts	PASS	-
3.4	§2.1049	Occupied Bandwidth	Reporting Only	PASS	-
3.5	§2.1051 §22.917(a) §24.238(a) §27.53(h)	Band Edge Measurement	< 43+10log10(P[Watts])	PASS	-
3.6	§2.1051 §22.917(a) §24.238(a) §27.53(h)	Conducted Emission	< 43+10log10(P[Watts])	PASS	-
3.7	§2.1053 §22.917(a) §24.238(a) §27.53(h)	Field Strength of Spurious Radiation	< 43+10log10(P[Watts])	PASS	Under limit 35.51 dB at 5135.000 MHz
3.8	§2.1055 §22.355	Frequency Stability for Temperature & Voltage	< 2.5 ppm for Part 22 Within Authorized Band	PASS	-
	§2.1055 §24.235 §27.54				



# 1 General Description

## 1.1 Applicant

Motorola Mobility, LLC

222 W Merchandise Mart Plaza, Suite 1800, Chicago, IL 60654, United States

## 1.2 Manufacturer

Motorola Mobility, LLC

222 W Merchandise Mart Plaza, Suite 1800, Chicago, IL 60654, United States

## 1.3 Product Feature of Equipment Under Test

Product Feature	
Equipment	Mobile Cellular Phone
Brand Name	Motorola
Model Name	4247
FCC ID	IHDT56QG1
IMEI Code / HW Version	355488060038054 / P2B 355488060050018 / EVT
EUT supports Radios application	GSM/EGPRS/WCDMA/HSPA/LTE WLAN 11b/g/n HT20 Bluetooth v3.0 EDR Bluetooth v4.0 LE
EUT Stage	Production Unit

Remark: The above EUT's information was declared by manufacturer. Please refer to the specifications or user's manual for more detailed description.

Accessory List	
AC Adapter	Brand Name : Motorola
	Model Name : SPN5810A
Earphone	Brand Name : Motorola
	Model Name : SJYN1181B
Battery	Brand Name : Motorola
	Model Name : FC40



### 1.4 Product Specification subjective to this standard

Product Specification subjective to this standard	
<b>Tx Frequency</b>	GSM850: 824.2 MHz ~ 848.8 MHz GSM1900: 1850.2 MHz ~ 1909.8MHz WCDMA Band V: 826.4 MHz ~ 846.6 MHz WCDMA Band IV : 1712.4 MHz ~ 1752.6 MHz WCDMA Band II: 1852.4 MHz ~ 1907.6 MHz
<b>Rx Frequency</b>	GSM850: 869.2 MHz ~ 893.8 MHz GSM1900: 1930.2 MHz ~ 1989.8 MHz WCDMA Band V: 871.4 MHz ~ 891.6 MHz WCDMA Band IV : 2112.4 MHz ~ 2152.6 MHz WCDMA Band II: 1932.4 MHz ~ 1987.6 MHz
<b>Maximum Output Power to Antenna</b>	WCDMA Band V : 23.45 dBm WCDMA Band IV : 23.22 dBm WCDMA Band II : 23.32 dBm
<b>99% Occupied Bandwidth</b>	WCDMA Band V: 4.16MHz WCDMA Band IV: 4.19MHz WCDMA Band II: 4.19MHz
<b>Antenna Type</b>	Fixed Internal Antenna
<b>Type of Modulation</b>	WCDMA: QPSK (Uplink) HSDPA: 64QAM (Downlink) HSUPA: QPSK (Uplink)

**Remark:**

1. For other wireless features of this EUT, test report will be issued separately.
2. The above EUT's information was declared by manufacturer. Please refer to the specifications or user's manual for more detailed description.
3. Excluding effective radiated power and equivalent isotropic radiated power tests, the GSM850 and GSM1900 test results which can be referred to appendix A.

### 1.5 Modification of EUT

No modifications are made to the EUT during all test items.



### 1.6 Maximum ERP/EIRP Power, Frequency Tolerance, and Emission Designator

FCC Rule	System	Type of Modulation	Maximum ERP/EIRP (W)	Frequency Tolerance (ppm)	Emission Designator
Part 22	GSM850 GSM	GMSK	0.938	-	-
Part 22	GSM850 EDGE class 8	8PSK	0.200	-	-
Part 22	WCDMA Band V RMC 12.2Kbps	QPSK	0.130	0.0132 ppm	4M16F9W
Part 24	GSM1900 GSM	GMSK	1.690	-	-
Part 24	GSM1900 EDGE class 8	8PSK	0.566	-	-
Part 24	WCDMA Band II RMC 12.2Kbps	QPSK	0.323	0.0011 ppm	4M19F9W
Part 27	WCDMA Band IV RMC 12.2Kbps	QPSK	0.518	0.0242 ppm	4M19F9W

### 1.7 Testing Location

Sporton Lab is accredited to ISO 17025 by Taiwan Accreditation Foundation (TAF code : 1190) and the FCC designation No. TW1022 under the FCC 2.948(e) by Mutual Recognition Agreement (MRA) in FCC Test.

<b>Test Site</b>	SPORTON INTERNATIONAL INC.	
<b>Test Site Location</b>	No. 52, Hwa Ya 1 <sup>st</sup> Rd., Hwa Ya Technology Park, Kwei-Shan District, Tao Yuan City, Taiwan, R.O.C. TEL: +886-3-327-3456 FAX: +886-3-328-4978	
<b>Test Site No.</b>	<b>Sporton Site No.</b>	
	TH02-HY	03CH07-HY



## **1.8 Applicable Standards**

According to the specifications of the manufacturer, the EUT must comply with the requirements of the following standards:

- 47 CFR Part 2, 22(H), 24(E), 27(L)
- ANSI / TIA / EIA-603-C-2004
- FCC KDB 971168 D01 Power Meas. License Digital Systems v02r02

**Remark:**

1. All test items were verified and recorded according to the standards and without any deviation during the test.
2. This EUT has also been tested and complied with the requirements of FCC Part 15, Subpart B, recorded in a separate test report.



## 2 Test Configuration of Equipment Under Test

### 2.1 Test Mode

Antenna port conducted and radiated test items were performed according to KDB 971168 D01 Power Meas. License Digital Systems v02r02 with maximum output power.

Radiated measurements were performed with rotating EUT in different three orthogonal test planes to find the maximum emission.

Radiated emissions were investigated as following frequency range:

1. 30 MHz to 9000 MHz for WCDMA Band V.
2. 30 MHz to 18000 MHz for WCDMA Band IV
3. 30 MHz to 19000 MHz for WCDMA Band II.

All modes and data rates and positions were investigated.

Test modes are chosen to be reported as the worst case configuration below:

Test Modes		
Band	Radiated TCs	Conducted TCs
WCDMA Band V	■ RMC 12.2Kbps Link	■ RMC 12.2Kbps Link
WCDMA Band II	■ RMC 12.2Kbps Link	■ RMC 12.2Kbps Link
WCDMA Band IV	■ RMC 12.2Kbps Link	■ RMC 12.2Kbps Link

**Note:** The maximum power levels are chosen to test as the worst case configuration as follows:

RMC 12.2Kbps mode for WCDMA band V and WCDMA band IV,

RMC 12.2Kbps mode for WCDMA band II, only these modes were used for all tests.

only these modes were used for all tests. In addition to above worst-case test, below investigating on all data rates, and all modes are compliance with each FCC test case which has specific test limits. For spurious emissions at antenna port, the EUT was investigated the band edges on low and high channels, and the unwanted spurious emissions on middle channel for all modes, the results are pass, then only the worst-results were reported in the test report. The Radiated Spurious emissions for GSM/GPRS/EGPRS/HSDPA modes were investigated on the middle channel and the passed results were not worst than those data tested from the highest power channels.



Conducted Power Measurement Results:

Conducted Power (*Unit: dBm)									
Band	WCDMA Band V			WCDMA Band II			WCDMA Band IV		
Channel	4132	4182	4233	9262	9400	9538	1312	1413	1513
Frequency	826.4	836.4	846.6	1852.4	1880	1907.6	1712.4	1732.6	1752.6
RMC 12.2K	23.03	23.33	23.45	23.32	23.03	23.03	23.22	23.19	23.08
HSDPA Subtest-1	21.71	21.88	21.90	21.40	21.57	21.50	21.60	21.72	21.45
HSDPA Subtest-2	21.70	21.92	21.91	21.41	21.51	21.50	21.62	21.68	21.42
HSDPA Subtest-3	21.66	21.91	21.81	21.39	21.62	21.41	21.60	21.77	21.40
HSDPA Subtest-4	21.65	21.97	21.80	21.33	21.56	21.40	21.60	21.76	21.42
HSUPA Subtest-1	21.61	22.15	21.66	21.57	21.52	22.40	21.33	21.46	21.10
HSUPA Subtest-2	21.25	20.98	21.38	20.93	21.10	21.40	20.51	20.40	20.34
HSUPA Subtest-3	21.10	20.69	21.01	20.80	20.80	21.40	20.58	20.15	20.10
HSUPA Subtest-4	21.28	21.25	21.31	21.30	21.34	21.40	21.10	20.99	20.93
HSUPA Subtest-5	22.23	22.20	22.40	21.10	21.02	21.09	21.70	21.60	21.39

## 2.2 Connection Diagram of Test System

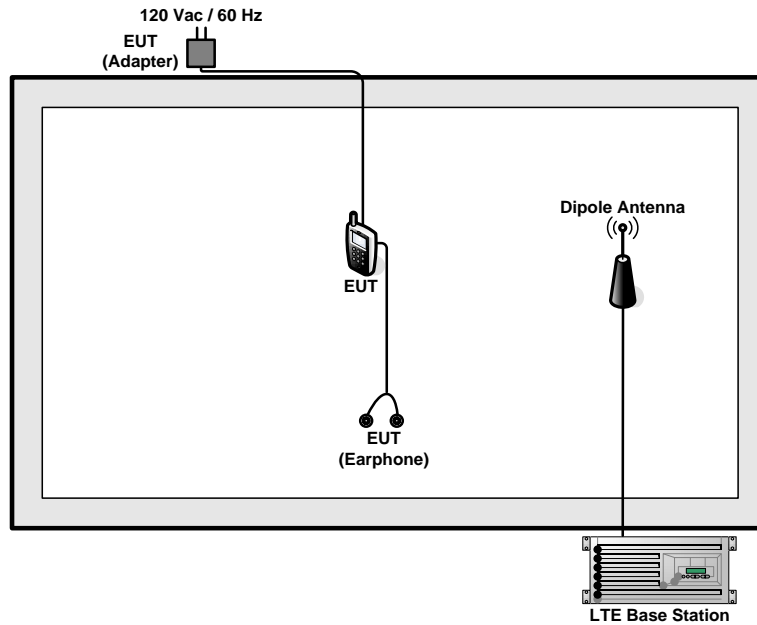

## 2.3 Support Unit used in test configuration

Item	Equipment	Trade Name	Model No.	FCC ID	Data Cable	Power Cord
1.	System Simulator	R&S	CMU 200	N/A	N/A	Unshielded, 1.8 m

## 2.4 Measurement Results Explanation Example

For all conducted test items:

The offset level is set in the spectrum analyzer to compensate the RF cable loss and attenuator factor between RF conducted output port and spectrum analyzer. With the offset compensation, the spectrum analyzer reading level will be exactly the RF output level.

The spectrum analyzer offset is derived from RF cable loss and attenuator factor.

*Offset = RF cable loss + attenuator factor.*

The following shows an offset computation example with RF cable loss 4.2 dB and a 10dB attenuator.

Example :

$$\begin{aligned} \text{Offset(dB)} &= \text{RF cable loss(dB)} + \text{attenuator factor(dB)} \\ &= 4.2 + 10 = 14.2 \text{ (dB)} \end{aligned}$$

### **3 Test Result**

#### **3.1 Conducted Output Power Measurement**

##### **3.1.1 Description of the Conducted Output Power Measurement**

A system simulator was used to establish communication with the EUT. Its parameters were set to enforce EUT transmitting at the maximum power. The measured power in the radio frequency on the transmitter output terminals shall be reported.

##### **3.1.2 Measuring Instruments**

The measuring equipment is listed in the section 4 of this test report.

##### **3.1.3 Test Procedures**

1. The transmitter output port was connected to the system simulator.
2. Set EUT at maximum power through system simulator.
3. Select lowest, middle, and highest channels for each band and different modulation.
4. Measure the maximum burst average power for GSM and maximum average power for other modulation signal.

##### **3.1.4 Test Setup**

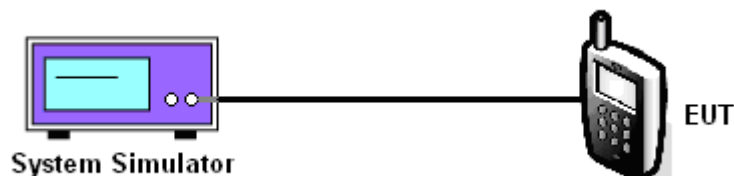



3.1.5 Test Result of Conducted Output Power

Cellular Band			
Modes	WCDMA Band V (RMC 12.2Kbps)		
Channel	4132 (Low)	4182 (Mid)	4233 (High)
Frequency (MHz)	826.4	836.4	846.6
Conducted Power (dBm)	23.03	23.33	23.45

PCS Band			
Modes	WCDMA Band II (RMC 12.2Kbps)		
Channel	9262 (Low)	9400 (Mid)	9538 (High)
Frequency (MHz)	1852.4	1880	1907.6
Conducted Power (dBm)	23.32	23.03	23.03

AWS Band			
Modes	WCDMA Band IV (RMC 12.2Kbps)		
Channel	1312(Low)	1413 (Mid)	1513 (High)
Frequency (MHz)	1712.4	1732.6	1752.6
Conducted Power (dBm)	23.22	23.19	23.08

Note: maximum average power for WCDMA.

## 3.2 Peak-to-Average Ratio

### 3.2.1 Description of the PAR Measurement

The peak-to-average ratio (PAR) of the transmission may not exceed 13 dB.

### 3.2.2 Measuring Instruments

The measuring equipment is listed in the section 4 of this test report.

### 3.2.3 Test Procedures

1. The testing follows FCC KDB 971168 v02r02 Section 5.7.1.
2. The EUT was connected to spectrum analyzer and system simulator via a power divider.
3. Set EUT to transmit at maximum output power.
4. When the duty cycle is less than 98%, then signal gating will be implemented on the spectrum analyzer by triggering from the system simulator.
5. Set the CCDF (Complementary Cumulative Distribution Function) option of the spectrum analyzer.  
Record the maximum PAPR level associated with a probability of 0.1%.

### 3.2.4 Test Setup

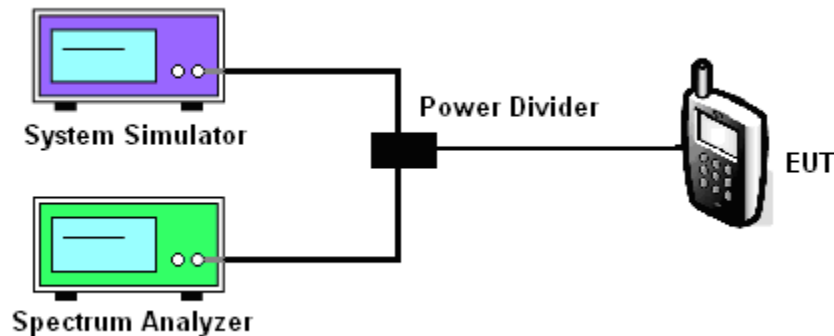



### 3.2.5 Test Result of Peak-to-Average Ratio

Cellular Band			
Modes	WCDMA Band V (RMC 12.2Kbps)		
Channel	4132 (Low)	4182 (Mid)	4233 (High)
Frequency (MHz)	826.4	836.4	846.6
Peak-to-Average Ratio (dB)	3.28	3.28	3.28

PCS Band			
Modes	WCDMA Band II (RMC 12.2Kbps)		
Channel	9262 (Low)	9400 (Mid)	9538 (High)
Frequency (MHz)	1852.4	1880	1907.6
Peak-to-Average Ratio (dB)	3.20	3.12	3.12

AWS Band			
Modes	WCDMA Band IV (RMC 12.2Kbps)		
Channel	1312(Low)	1413 (Mid)	1513 (High)
Frequency (MHz)	1712.4	1732.6	1752.6
Peak-to-Average Ratio (dB)	2.88	2.72	2.52



### 3.2.6 Test Result (Plots) of Peak-to-Average Ratio

<b>Band :</b>	WCDMA Band V	<b>Test Mode :</b>	RMC 12.2Kbps Link (QPSK)
---------------	--------------	--------------------	--------------------------

#### Peak-to-Average Ratio on Channel 4132 (826.4 MHz)

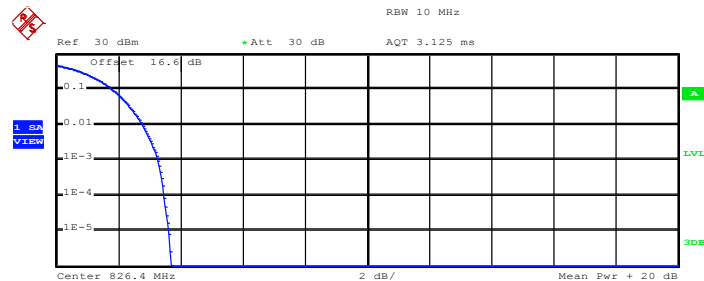

Complementary Cumulative Distribution Function (100000 samples)

Trace 1  
 Mean 22.54 dBm  
 Peak 26.23 dBm  
 Crest 3.69 dB

10 %	1.84 dB
1 %	2.80 dB
.1 %	3.28 dB
.01 %	3.48 dB

Date: 6.MAY.2015 14:51:09

#### Peak-to-Average Ratio on Channel 4182 (836.4 MHz)

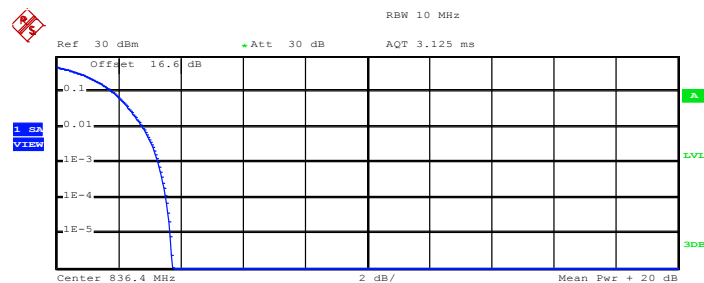

Complementary Cumulative Distribution Function (100000 samples)

Trace 1  
 Mean 22.78 dBm  
 Peak 26.51 dBm  
 Crest 3.73 dB

10 %	1.84 dB
1 %	2.80 dB
.1 %	3.28 dB
.01 %	3.52 dB

Date: 6.MAY.2015 14:51:17



Peak-to-Average Ratio on Channel 4233 (846.6 MHz)

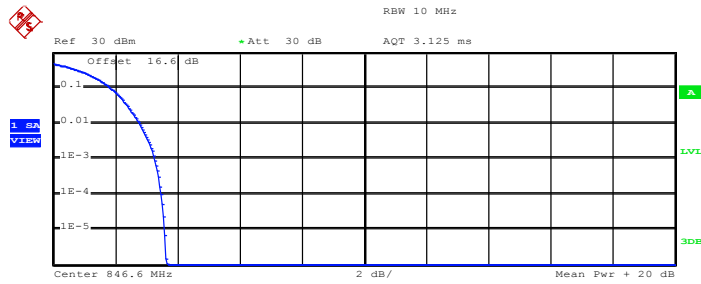

Complementary Cumulative Distribution Function (100000 samples)

Trace 1

Mean	22.66 dBm
Peak	26.30 dBm
Crest	3.64 dB
10 %	1.84 dB
1 %	2.80 dB
.1 %	3.28 dB
.01 %	3.48 dB

Date: 6.MAY.2015 14:51:26



<b>Band :</b>	WCDMA Band IV	<b>Test Mode :</b>	RMC 12.2Kbps Link (QPSK)
---------------	---------------	--------------------	--------------------------

**Peak-to-Average Ratio on Channel 1312 (1712.4 MHz)**

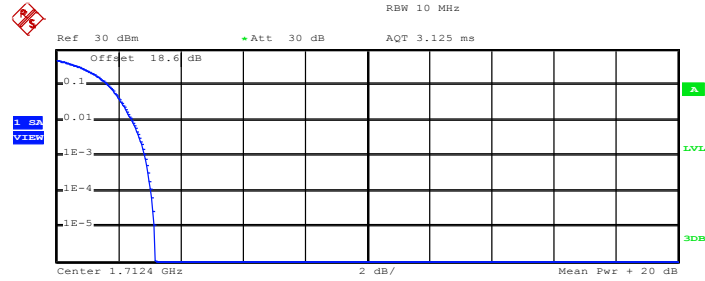

Complementary Cumulative Distribution Function (100000 samples)

Trace 1

Mean	17.25 dBm
Peak	20.44 dBm
Crest	3.19 dB
10 %	1.68 dB
1 %	2.44 dB
.1 %	2.88 dB
.01 %	3.04 dB

Date: 8.MAY.2015 18:25:21

**Peak-to-Average Ratio on Channel 1413 (1732.6 MHz)**

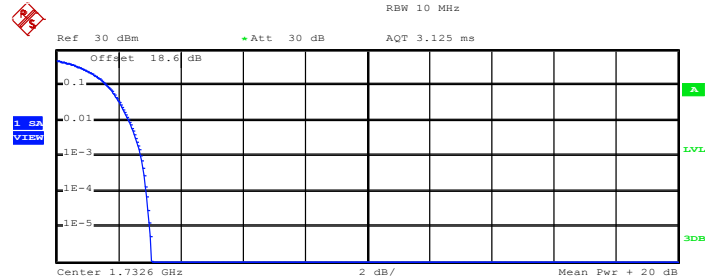

Complementary Cumulative Distribution Function (100000 samples)

Trace 1

Mean	17.44 dBm
Peak	20.52 dBm
Crest	3.07 dB
10 %	1.64 dB
1 %	2.36 dB
.1 %	2.72 dB
.01 %	2.92 dB

Date: 8.MAY.2015 18:25:29



Peak-to-Average Ratio on Channel 1513 (1752.6 MHz)

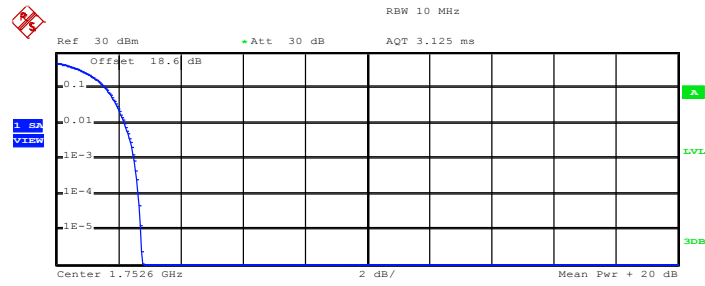

Complementary Cumulative Distribution Function (100000 samples)

Trace 1

Mean	17.68 dBm
Peak	20.44 dBm
Crest	2.76 dB
10 %	1.60 dB
1 %	2.20 dB
.1 %	2.52 dB
.01 %	2.64 dB

Date: 8.MAY.2015 18:25:37



<b>Band :</b>	WCDMA Band II	<b>Test Mode :</b>	RMC 12.2Kbps Link (QPSK)
---------------	---------------	--------------------	--------------------------

**Peak-to-Average Ratio on Channel 9262 (1852.4 MHz)**

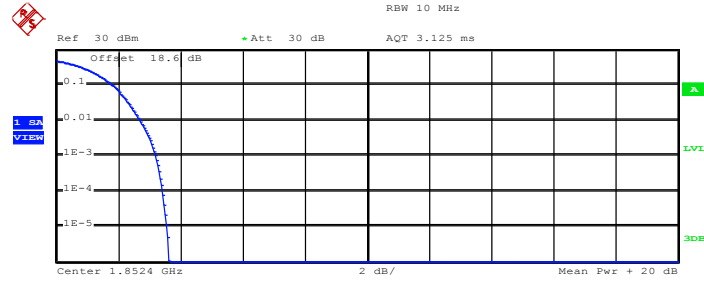

Complementary Cumulative Distribution Function (100000 samples)

Trace 1

Mean	22.82 dBm
Peak	26.44 dBm
Crest	3.63 dB
10 %	1.84 dB
1 %	2.72 dB
.1 %	3.20 dB
.01 %	3.44 dB

Date: 6.MAY.2015 15:03:47

**Peak-to-Average Ratio on Channel 9400 (1880.0 MHz)**

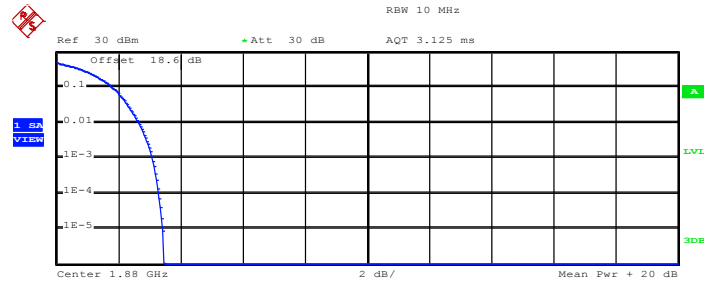

Complementary Cumulative Distribution Function (100000 samples)

Trace 1

Mean	23.40 dBm
Peak	26.87 dBm
Crest	3.47 dB
10 %	1.80 dB
1 %	2.68 dB
.1 %	3.12 dB
.01 %	3.32 dB

Date: 6.MAY.2015 15:03:55



Peak-to-Average Ratio on Channel 9538 (1907.6 MHz)

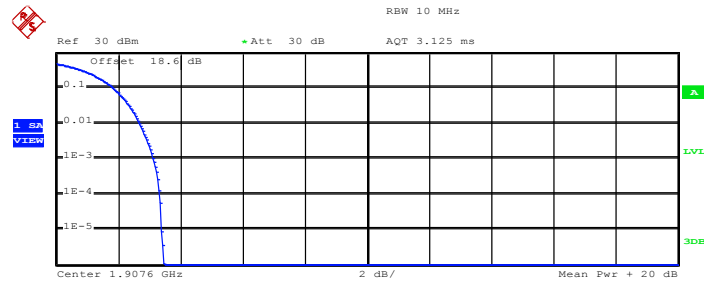

Complementary Cumulative Distribution Function (100000 samples)

Trace 1	
Mean	22.49 dBm
Peak	25.95 dBm
Crest	3.46 dB
10 %	1.84 dB
1 %	2.68 dB
.1 %	3.12 dB
.01 %	3.32 dB

Date: 6.MAY.2015 15:04:03



### 3.3 Effective Radiated Power and Effective Isotropic Radiated Power Measurement

#### 3.3.1 Description of the ERP/EIRP Measurement

The substitution method, in ANSI / TIA / EIA-603-C-2004, was used for ERP/EIRP measurement, and the spectrum analyzer configuration follows KDB 971168 D01 Power Meas. License Digital Systems v02r02. The ERP of mobile transmitters must not exceed 7 Watts (Cellular Band) and the EIRP of mobile transmitters are limited to 2 Watts (PCS Band) and 1 Watts (AWS Band).

#### 3.3.2 Measuring Instruments

The measuring equipment is listed in the section 4 of this test report.

#### 3.3.3 Test Procedures

1. The EUT was placed on a non-conductive rotating platform 0.8 meters high in a semi-anechoic chamber. The radiated emission at the fundamental frequency was measured at 3 m with a test antenna and a spectrum analyzer with RMS detector per section 5. of KDB 971168 D01.
2. During the measurement, the system simulator parameters were set to force the EUT transmitting at maximum output power. The maximum emission was recorded from analyzer power level (LVL) from the 360 degrees rotation of the turntable and the test antenna raised and lowered over a range from 1 to 4 meters in both horizontally and vertically polarized orientations.
3. Effective Isotropic Radiated Power (EIRP) was measured by substitution method according to TIA/EIA-603-C. The EUT was replaced by dipole antenna (substitution antenna) at the same location, and then a known power from S.G. was applied into the dipole antenna through a Tx cable, and then recorded the maximum Analyzer reading through raised and lowered the test antenna. The correction factor (in dB) = S.G. - Tx Cable loss + Substitution antenna gain - Analyzer reading. Then the EUT's EIRP was calculated with the correction factor,  $EIRP = LVL + \text{Correction factor}$  and  $ERP = EIRP - 2.15$ .

	GSM/GPRS/EDGE	WCDMA/HSPA
SPAN	500kHz	10MHz
RBW	10kHz	100kHz
VBW	30kHz	300kHz
Detector	RMS	RMS
Trace	Average	Average
Average Type	Power	Power
Sweep Count	100	100

### 3.3.4 Test Setup

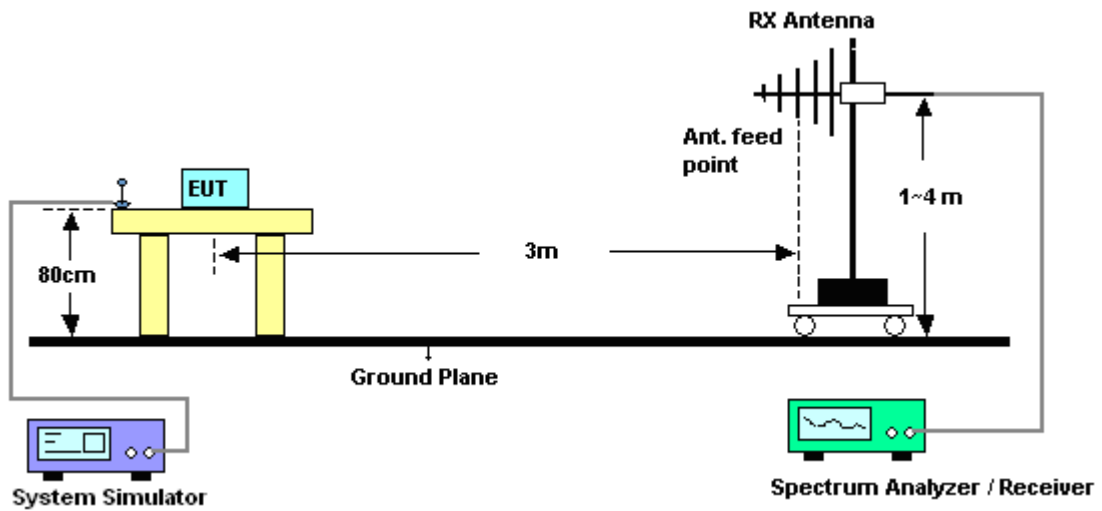



3.3.5 Test Result of ERP

GSM850 (GPRS class 8) Radiated Power ERP					
Channel	Frequency (MHz)	Horizontal		Vertical	
		ERP(dBm)	ERP(W)	ERP(dBm)	ERP(W)
Lowest	824.2	17.67	0.0585	28.3	0.6761
Middle	836.4	18.58	0.0721	29.41	0.8730
Highest	848.8	19.23	0.0838	29.72	0.9376
Limit	ERP < 7W	Result		PASS	

GSM850 (EDGE class 8) Radiated Power ERP					
Channel	Frequency (MHz)	Horizontal		Vertical	
		ERP(dBm)	ERP(W)	ERP(dBm)	ERP(W)
Lowest	824.2	11.38	0.0137	21.72	0.1486
Middle	836.4	11.5	0.0141	22.46	0.1762
Highest	848.8	12.55	0.0180	23.01	0.2000
Limit	ERP < 7W	Result		PASS	

WCDMA Band V (RMC 12.2Kbps) Radiated Power ERP					
Channel	Frequency (MHz)	Horizontal		Vertical	
		ERP(dBm)	ERP(W)	ERP(dBm)	ERP(W)
Lowest	826.4	10.63	0.0116	19.93	0.0984
Middle	836.4	11.02	0.0126	19.92	0.0982
Highest	846.6	12.18	0.0165	20.12	0.1028
Limit	ERP < 7W	Result		PASS	



3.3.6 Test Result of EIRP

GSM1900 (GPRS class 8) Radiated Power EIRP					
Channel	Frequency (MHz)	Horizontal		Vertical	
		ERP(dBm)	ERP(W)	ERP(dBm)	ERP(W)
Lowest	1850.2	30.81	1.2050	27.64	0.5808
Middle	1880.0	31.58	1.4388	28.07	0.6412
Highest	1908.8	32.28	1.6904	28.62	0.7278
Limit	EIRP < 2W	Result		PASS	

GSM1900 (EDGE class 8) Radiated Power EIRP					
Channel	Frequency (MHz)	Horizontal		Vertical	
		ERP(dBm)	ERP(W)	ERP(dBm)	ERP(W)
Lowest	1850.2	25.81	0.3811	22.61	0.1824
Middle	1880.0	26.89	0.4887	23.22	0.2099
Highest	1908.8	27.53	0.5662	23.9	0.2455
Limit	EIRP < 2W	Result		PASS	

WCDMA Band II (RMC 12.2Kbps) Radiated Power EIRP					
Channel	Frequency (MHz)	Horizontal		Vertical	
		ERP(dBm)	ERP(W)	ERP(dBm)	ERP(W)
Lowest	1852.4	24.75	0.299	22.24	0.167
Middle	1880.0	25.09	0.323	22.53	0.179
Highest	1907.6	24.96	0.313	22.33	0.171
Limit	EIRP < 2W	Result		PASS	

WCDMA Band IV(RMC 12.2Kbps) Radiated Power EIRP					
Channel	Frequency (MHz)	Horizontal		Vertical	
		ERP(dBm)	ERP(W)	ERP(dBm)	ERP(W)
Lowest	1712.4	26.66	0.463	25.67	0.369
Middle	1732.6	26.63	0.460	25.15	0.327
Highest	1752.6	27.14	0.518	24.83	0.304
Limit	EIRP < 1W	Result		PASS	

## 3.4 99% Occupied Bandwidth and 26dB Bandwidth Measurement

### 3.4.1 Description of 99% Occupied Bandwidth and 26dB Bandwidth Measurement

The 99% occupied bandwidth is the width of a frequency band such that, below the lower and above the upper frequency limits, the mean powers emitted are each equal to a specified percentage 0.5% of the total mean transmitted power.

The emission bandwidth is defined as the width of the signal between two points, located at the 2 sides of the carrier frequency, outside of which all emissions are attenuated at least 26 dB below the transmitter power.

### 3.4.2 Measuring Instruments

The measuring equipment is listed in the section 4 of this test report.

### 3.4.3 Test Procedures

1. The testing follows FCC KDB 971168 v02r02 Section 4.2.
2. The EUT was connected to the spectrum analyzer and system simulator via a power divider.
3. The RF output of the EUT was connected to the spectrum analyzer by RF cable and attenuator. The path loss was compensated to the results for each measurement.
4. The 99% occupied bandwidth were measured, set RBW= 1% of span, VBW= 3\*RBW, sample detector, trace maximum hold.
5. The 26dB bandwidth were measured, set RBW= 1% of EBW, VBW= 3\*RBW, peak detector, trace maximum hold.

### 3.4.4 Test Setup

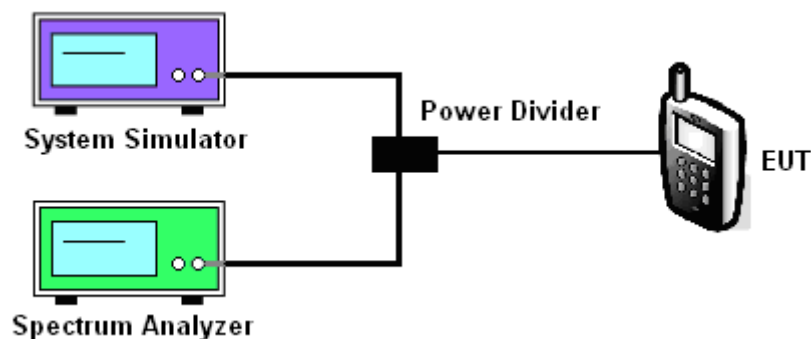



3.4.5 Test Result of Occupied Bandwidth and 26dB Bandwidth

Cellular Band			
Modes	WCDMA Band V (RMC 12.2Kbps)		
Channel	4132 (Low)	4182 (Mid)	4233 (High)
Frequency (MHz)	826.4	836.4	846.6
99% OBW (MHz)	4.14	4.15	4.16
26dB BW (MHz)	4.64	4.65	4.66

AWS Band			
Modes	WCDMA Band IV (RMC 12.2Kbps)		
Channel	1312(Low)	1413 (Mid)	1513 (High)
Frequency (MHz)	1712.4	1732.6	1752.6
99% OBW (MHz)	4.18	4.19	4.18
26dB BW (MHz)	4.68	4.68	4.68

PCS Band			
Modes	WCDMA Band II (RMC 12.2Kbps)		
Channel	9262 (Low)	9400 (Mid)	9538 (High)
Frequency (MHz)	1852.4	1880	1907.6
99% OBW (MHz)	4.18	4.19	4.18
26dB BW (MHz)	4.67	4.67	4.66



### 3.4.6 Test Result (Plots) of Occupied Bandwidth and 26dB Bandwidth

Band :	WCDMA Band V	Test Mode :	RMC 12.2Kbps Link (QPSK)
--------	--------------	-------------	--------------------------

#### 99% Occupied Bandwidth Plot on Channel 4132 (826.4 MHz)

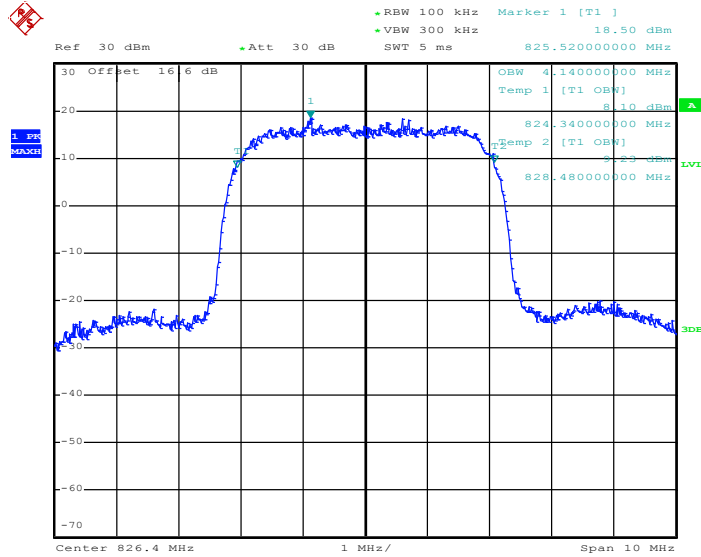

Date: 6.MAY.2015 14:42:02

#### 26dB Bandwidth Plot on Channel 4132 (826.4 MHz)

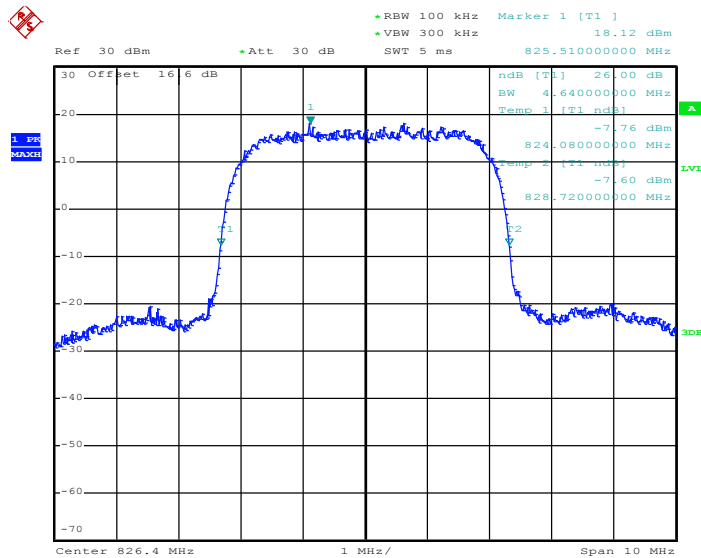

Date: 6.MAY.2015 14:40:23



99% Occupied Bandwidth Plot on Channel 4182 (836.4 MHz)

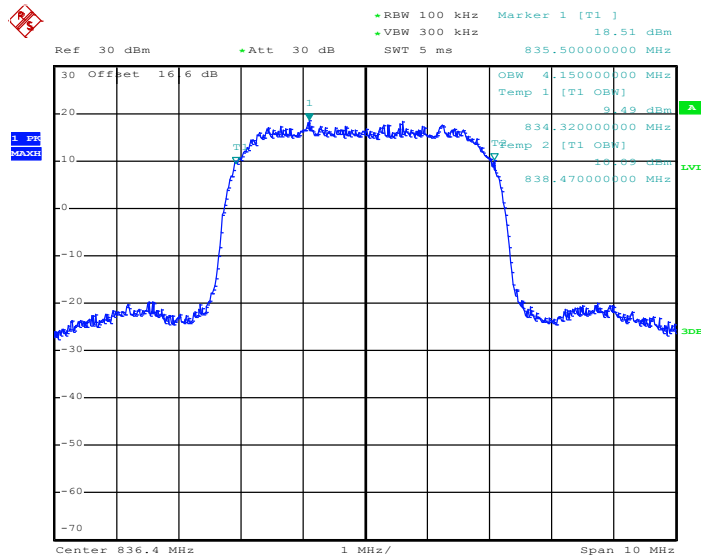

Date: 6.MAY.2015 14:42:30

26dB Bandwidth Plot on Channel 4182 (836.4 MHz)

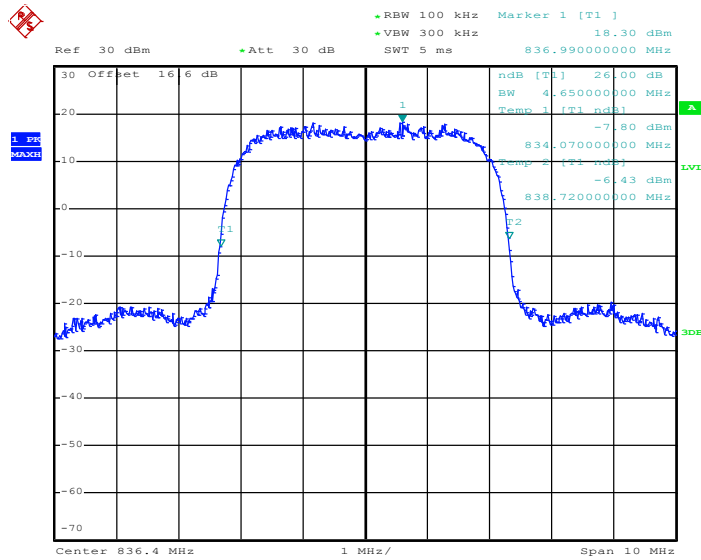

Date: 6.MAY.2015 14:40:51



99% Occupied Bandwidth Plot on Channel 4233 (846.6 MHz)

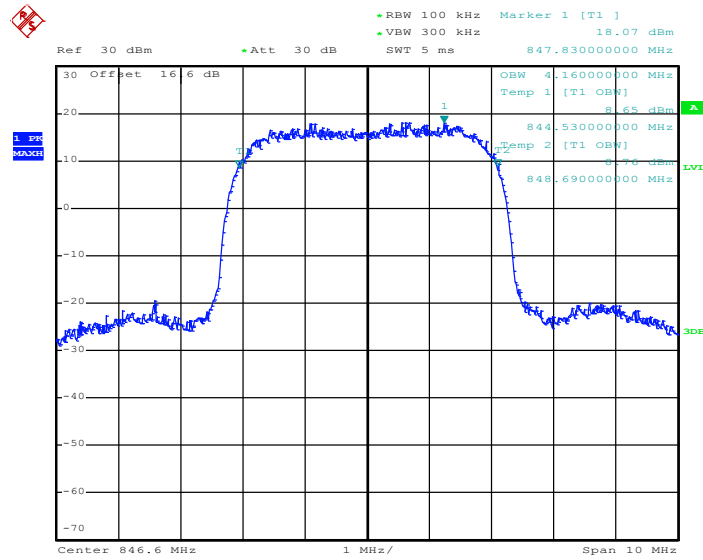

Date: 6.MAY.2015 14:42:58

26dB Bandwidth Plot on Channel 4233 (846.6 MHz)

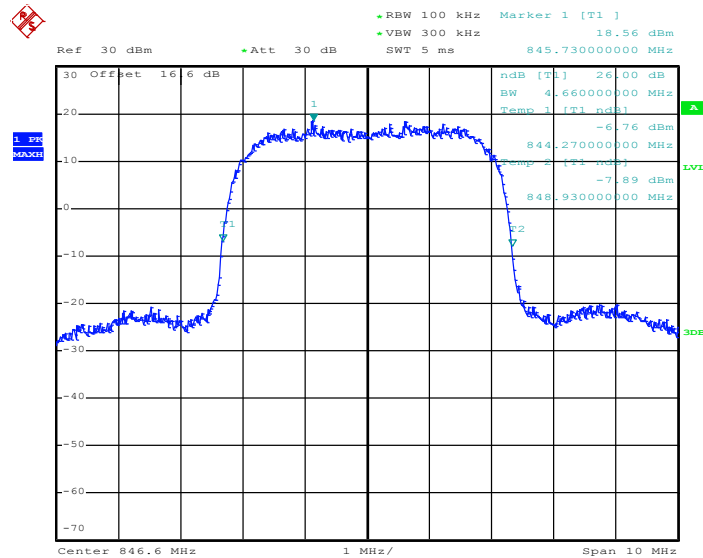

Date: 6.MAY.2015 14:41:19



<b>Band :</b>	WCDMA Band IV	<b>Test Mode :</b>	RMC 12.2Kbps Link (QPSK)
---------------	---------------	--------------------	--------------------------

99% Occupied Bandwidth Plot on Channel 1312 (1712.4 MHz)

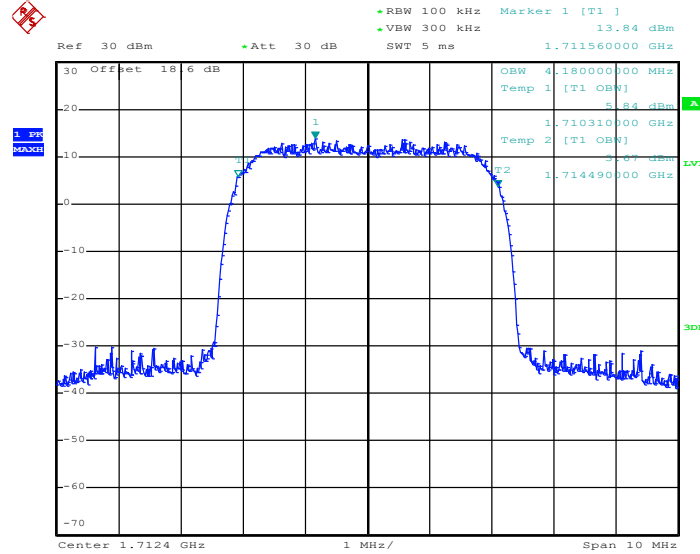

Date: 8.MAY.2015 18:18:38

26dB Bandwidth Plot on Channel 1312 (1712.4 MHz)

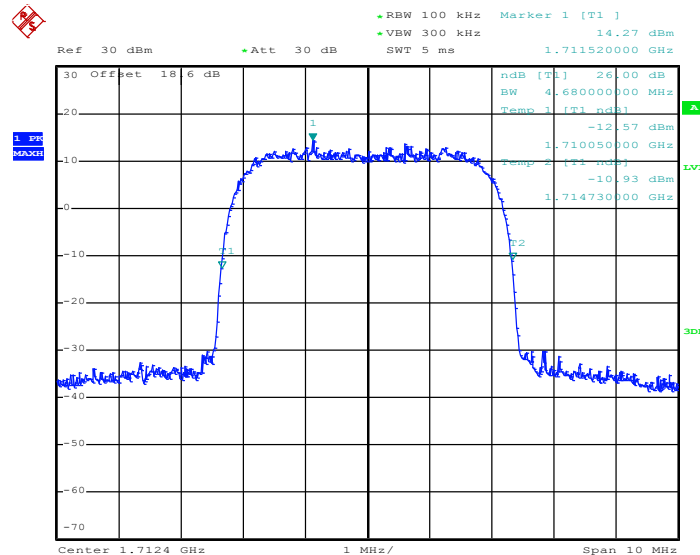

Date: 8.MAY.2015 18:16:24



### 99% Occupied Bandwidth Plot on Channel 1413 (1732.6 MHz)

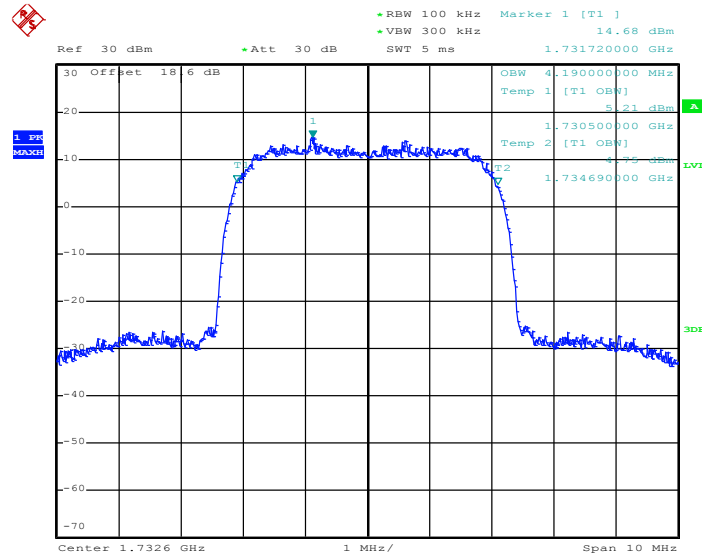

Date: 8.MAY.2015 18:19:06

### 26dB Bandwidth Plot on Channel 1413 (1732.6 MHz)

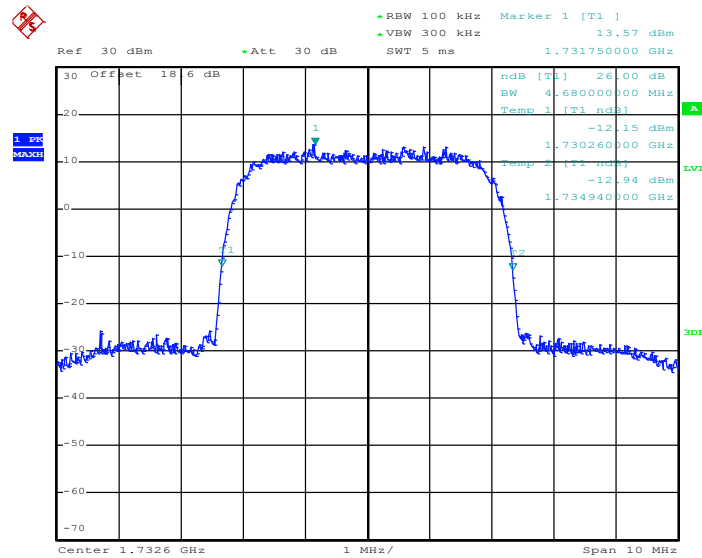

Date: 8.MAY.2015 18:16:52



99% Occupied Bandwidth Plot on Channel 1513 (1752.6 MHz)

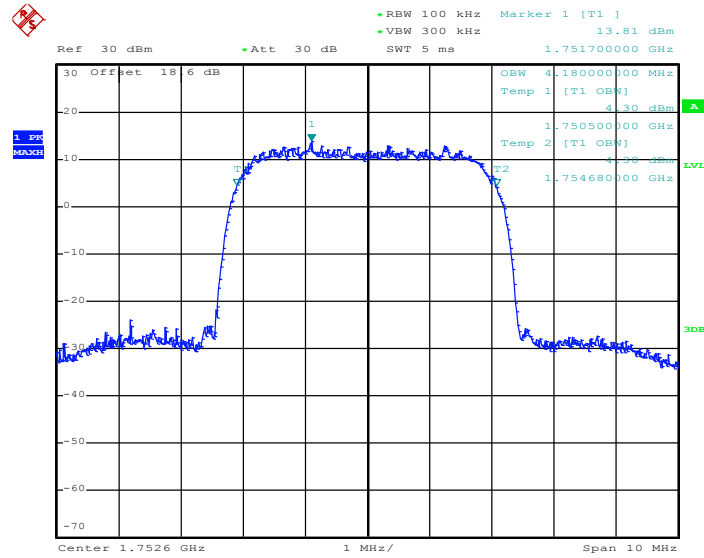

Date: 8.MAY.2015 18:19:34

26dB Bandwidth Plot on Channel 1513 (1752.6 MHz)

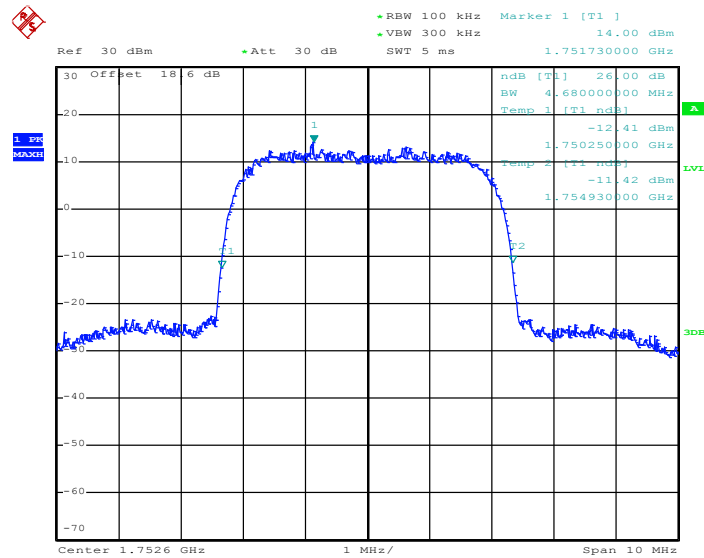

Date: 8.MAY.2015 18:17:20



<b>Band :</b>	WCDMA Band II	<b>Test Mode :</b>	RMC 12.2Kbps Link (QPSK)
---------------	---------------	--------------------	--------------------------

99% Occupied Bandwidth Plot on Channel 9262 (1852.4 MHz)

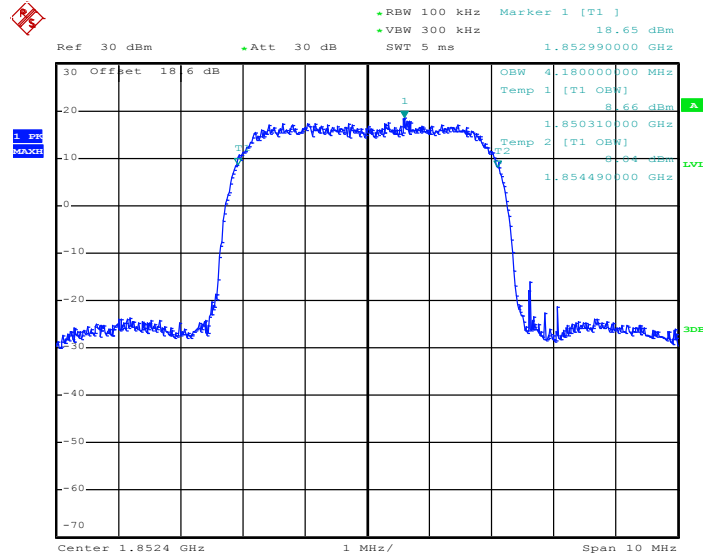

Date: 6.MAY.2015 14:56:43

26dB Bandwidth Plot on Channel 9262 (1852.4 MHz)

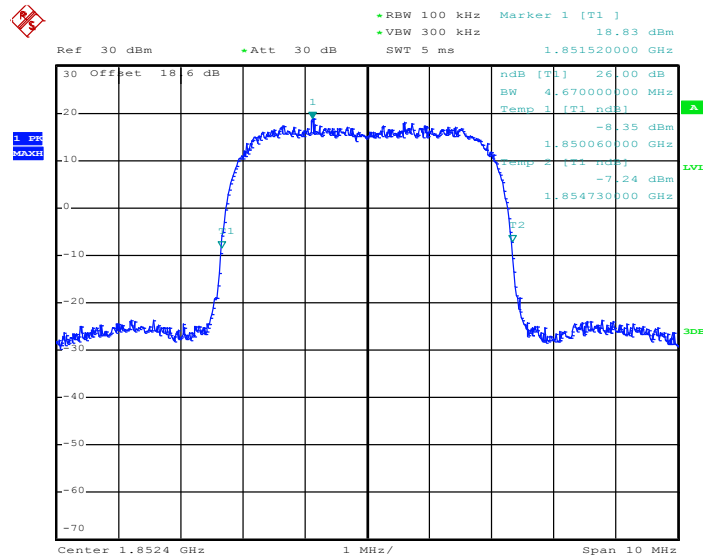

Date: 6.MAY.2015 14:55:12



### 99% Occupied Bandwidth Plot on Channel 9400 (1880.0 MHz)

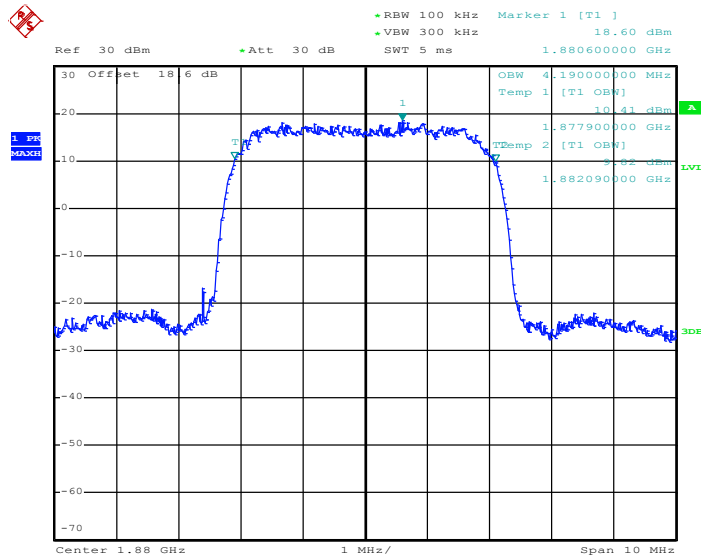

Date: 6.MAY.2015 14:57:11

### 26dB Bandwidth Plot on Channel 9400 (1880.0 MHz)

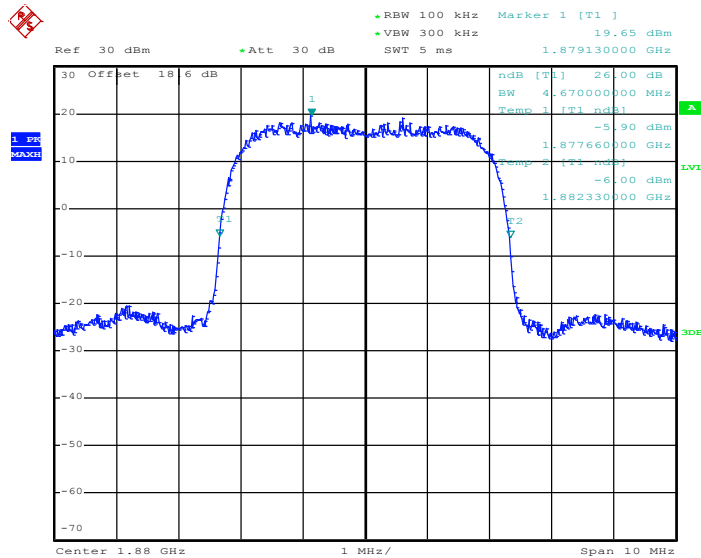

Date: 6.MAY.2015 14:55:40



99% Occupied Bandwidth Plot on Channel 9538 (1907.6 MHz)

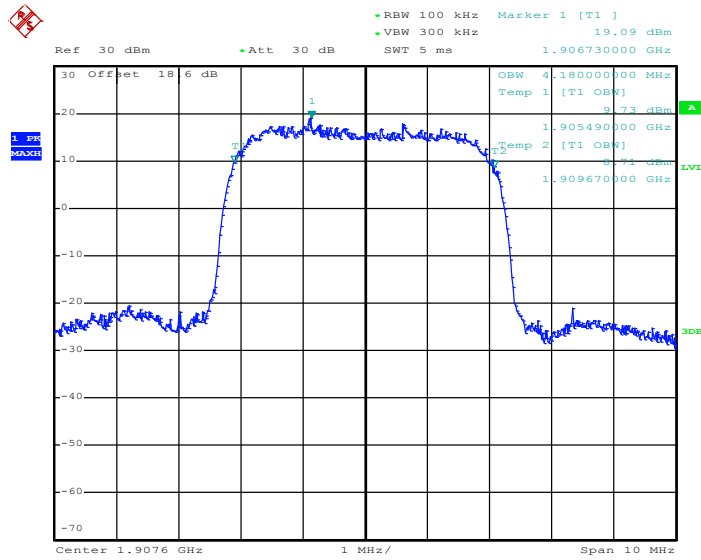

Date: 6.MAY.2015 14:57:39

26dB Bandwidth Plot on Channel 9538 (1907.6 MHz)

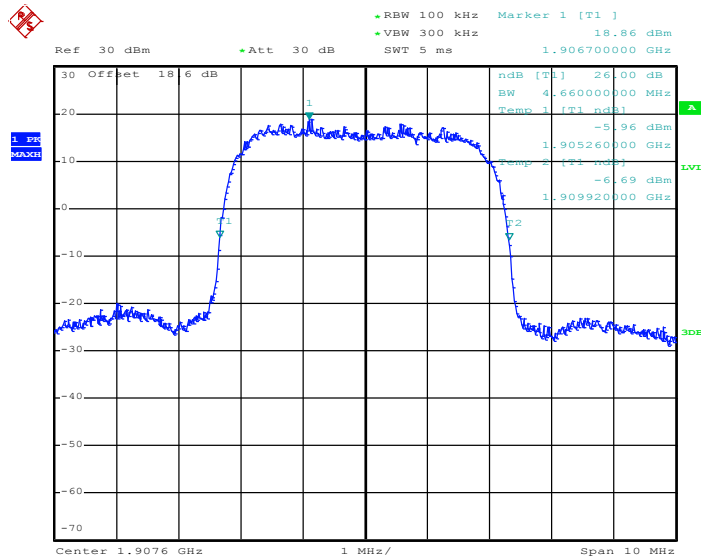

Date: 6.MAY.2015 14:56:08

## 3.5 Band Edge Measurement

### 3.5.1 Description of Band Edge Measurement

The power of any emission outside of the authorized operating frequency ranges must be lower than the transmitter power (P) by a factor of at least  $43 + 10 \log (P)$  dB.

### 3.5.2 Measuring Instruments

The measuring equipment is listed in the section 4 of this test report.

### 3.5.3 Test Procedures

1. The testing follows FCC KDB 971168 v02r02 Section 6.0.
2. The EUT was connected to the spectrum analyzer and system simulator via a power divider.
3. The RF output of EUT was connected to the spectrum analyzer by an RF cable and attenuator. The path loss was compensated to the results for each measurement.
4. The band edges of low and high channels for the highest RF powers were measured.
5. The RF fundamental frequency should be excluded against the limit line in the operating frequency band.
6. The limit line is derived from  $43 + 10\log(P)$  dB below the transmitter power P(Watts)  
 $= P(W) - [43 + 10\log(P)] \text{ (dB)}$   
 $= [30 + 10\log(P)] \text{ (dBm)} - [43 + 10\log(P)] \text{ (dB)}$   
 $= -13\text{dBm}.$

### 3.5.4 Test Setup

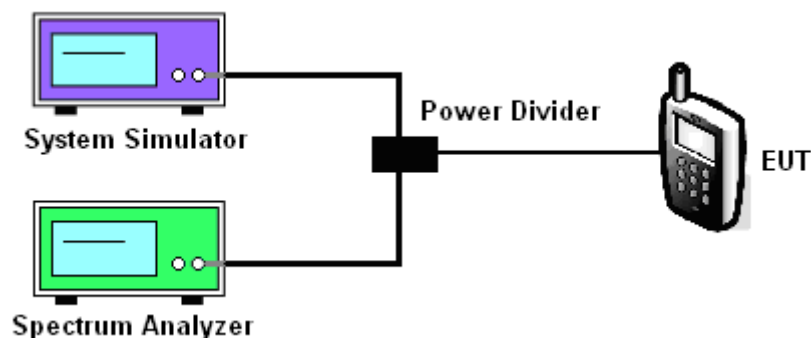



### 3.5.5 Test Result (Plots) of Conducted Band Edge

Band :	WCDMA Band V	Test Mode :	RMC 12.2Kbps Link (QPSK)
--------	--------------	-------------	--------------------------

#### Lower Band Edge Plot on Channel 4132 (826.4 MHz)

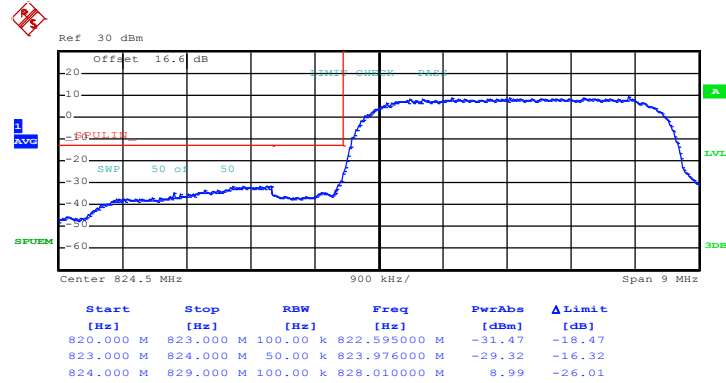

Date: 6.MAY.2015 14:44:29

#### Higher Band Edge Plot on Channel 4233 (846.6 MHz)

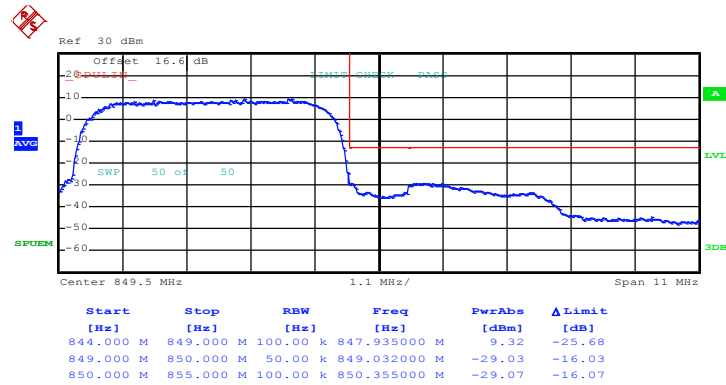

Date: 6.MAY.2015 14:45:51



<b>Band :</b>	WCDMA Band IV	<b>Test Mode :</b>	RMC 12.2Kbps Link (QPSK)
---------------	---------------	--------------------	--------------------------

Lower Band Edge Plot on Channel 1312 (1712.4 MHz)

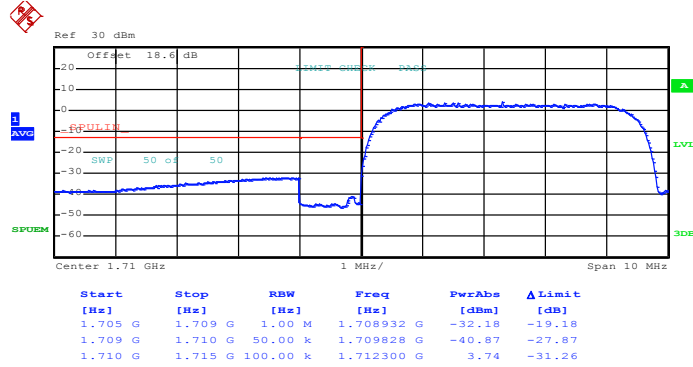

Date: 8.MAY.2015 18:21:03

Higher Band Edge Plot on Channel 1513 (1752.6 MHz)

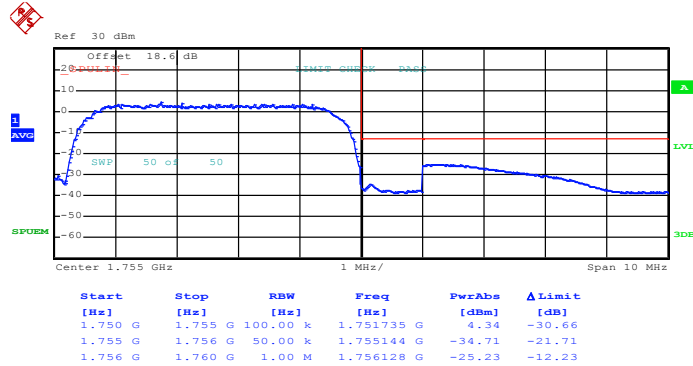

Date: 8.MAY.2015 18:22:26



Band :	WCDMA Band II	Test Mode :	RMC 12.2Kbps Link (QPSK)
--------	---------------	-------------	--------------------------

Lower Band Edge Plot on Channel 9262 (1852.4 MHz)

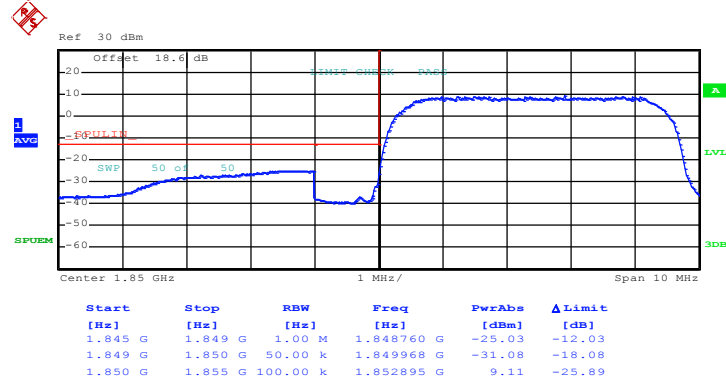

Date: 6.MAY.2015 14:59:25

Higher Band Edge Plot on Channel 9538 (1907.6 MHz)

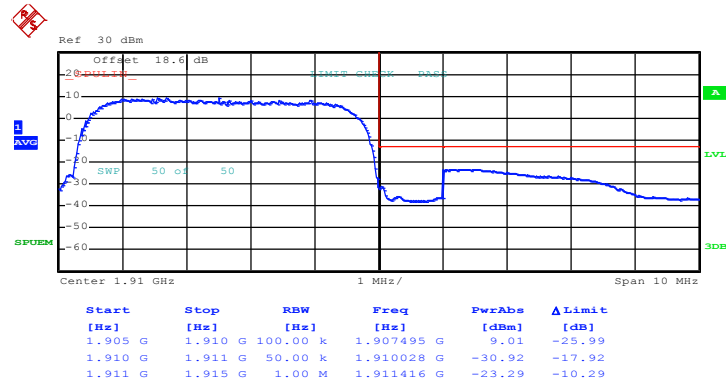

Date: 6.MAY.2015 15:00:47

## 3.6 Conducted Spurious Emission Measurement

### 3.6.1 Description of Conducted Spurious Emission Measurement

The power of any emission outside of the authorized operating frequency ranges must be lower than the transmitter power (P) by a factor of at least  $43 + 10 \log (P)$  dB.

It is measured by means of a calibrated spectrum analyzer and scanned from 30 MHz up to a frequency including its 10<sup>th</sup> harmonic.

### 3.6.2 Measuring Instruments

The measuring equipment is listed in the section 4 of this test report.

### 3.6.3 Test Procedures

1. The testing follows FCC KDB 971168 v02r02 Section 6.0.
2. The EUT was connected to the spectrum analyzer and system simulator via a power divider.
3. The RF output of EUT was connected to the spectrum analyzer by an RF cable and attenuator. The path loss was compensated to the results for each measurement.
4. The middle channel for the highest RF power within the transmitting frequency was measured.
5. The conducted spurious emission for the whole frequency range was taken.
6. The RF fundamental frequency should be excluded against the limit line in the operating frequency band.
7. The limit line is derived from  $43 + 10\log(P)$  dB below the transmitter power P(Watts)  
 $= P(W) - [43 + 10\log(P)]$  (dB)  
 $= [30 + 10\log(P)]$  (dBm) -  $[43 + 10\log(P)]$  (dB)  
 $= -13\text{dBm}$ .

### 3.6.4 Test Setup

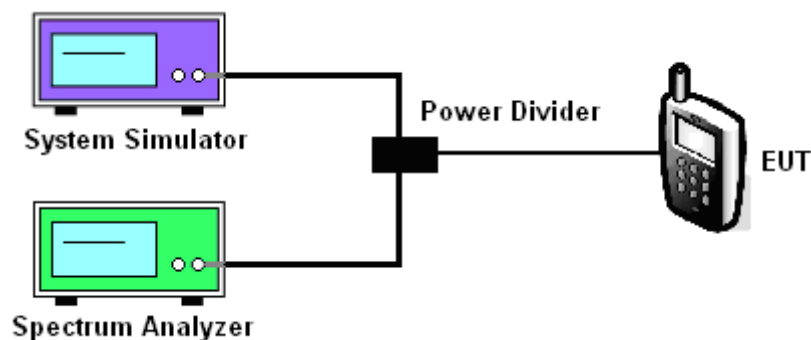



### 3.6.5 Test Result (Plots) of Conducted Spurious Emission

Band :	WCDMA Band V	Channel :	CH4132
Test Mode :	RMC 12.2Kbps Link (QPSK)	Frequency :	826.4 MHz

Conducted Spurious Emission Plot between 30MHz ~ 9GHz

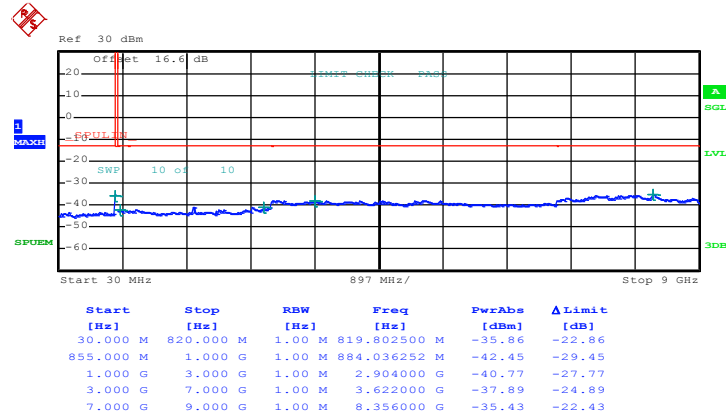

Date: 6.MAY.2015 14:48:53



Band :	WCDMA Band V	Channel :	CH4182
Test Mode :	RMC 12.2Kbps Link (QPSK)	Frequency :	836.4 MHz

Conducted Spurious Emission Plot between 30MHz ~ 9GHz

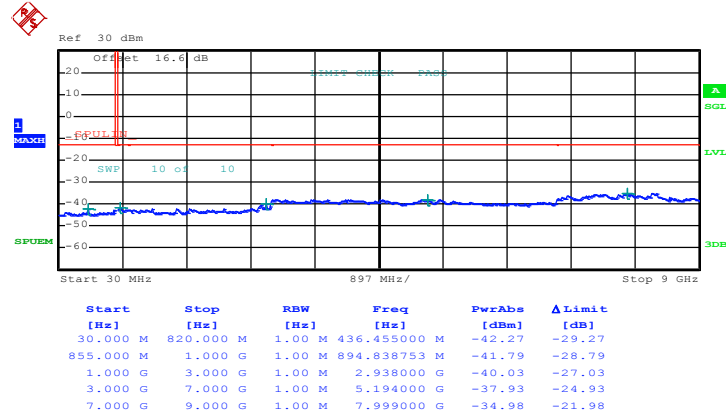

Date: 6.MAY.2015 14:49:18



Band :	WCDMA Band V	Channel :	CH4233
Test Mode :	RMC 12.2Kbps Link (QPSK)	Frequency :	846.6 MHz

Conducted Spurious Emission Plot between 30MHz ~ 9GHz

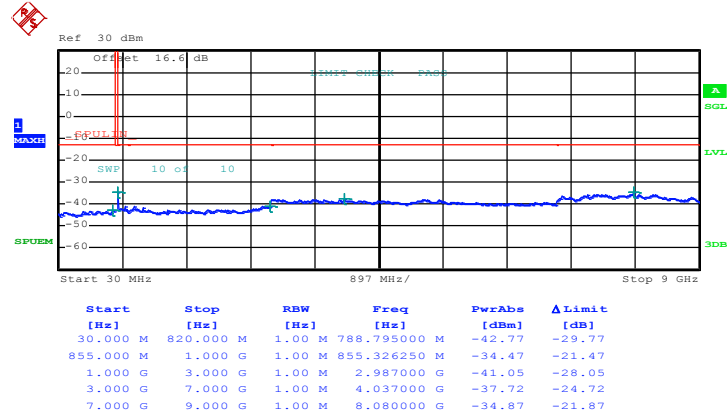

Date: 6.MAY.2015 14:49:43



<b>Band :</b>	WCDMA Band IV	<b>Channel :</b>	CH1312
<b>Test Mode :</b>	RMC 12.2Kbps Link (QPSK)	<b>Frequency :</b>	1712.4 MHz

Conducted Spurious Emission Plot between 30MHz ~ 18GHz

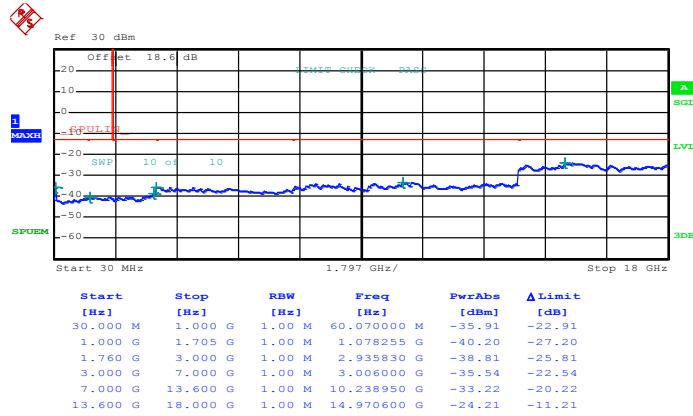

Date: 8.MAY.2015 18:23:59



<b>Band :</b>	WCDMA Band IV	<b>Channel :</b>	CH1413
<b>Test Mode :</b>	RMC 12.2Kbps Link (QPSK)	<b>Frequency :</b>	1732.6 MHz

**Conducted Spurious Emission Plot between 30MHz ~ 18GHz**

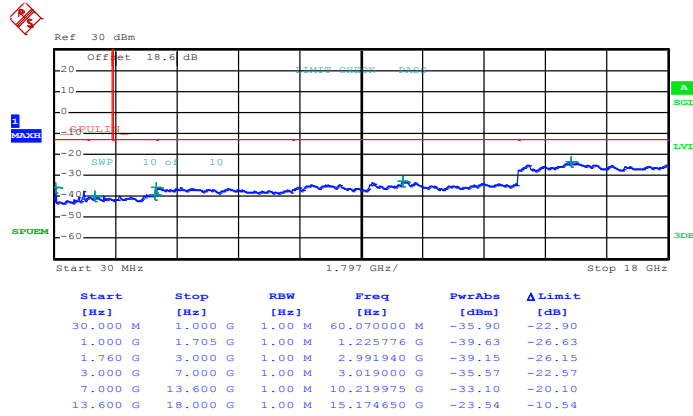

Date: 8.MAY.2015 18:24:24





<b>Band :</b>	WCDMA Band II	<b>Channel :</b>	CH9262
<b>Test Mode :</b>	RMC 12.2Kbps Link (QPSK)	<b>Frequency :</b>	1852.4 MHz

Conducted Spurious Emission Plot between 30MHz ~ 19.1GHz

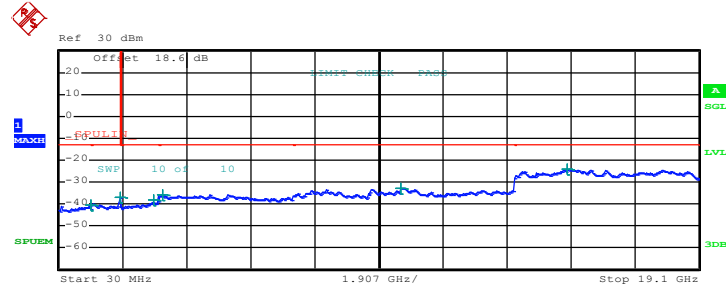

Start [Hz]	Stop [Hz]	RBW [Hz]	Freq [Hz]	PwrAbs [dBm]	Δ Limit [dB]
30.000 M	1.000 G	1.00 M	989.330000 M	-40.36	-27.36
1.000 G	1.845 G	1.00 M	1.843733 G	-37.21	-24.21
1.915 G	3.000 G	1.00 M	2.860306 G	-38.31	-25.31
3.000 G	7.000 G	1.00 M	3.127000 G	-35.93	-22.93
7.000 G	13.600 G	1.00 M	10.222450 G	-32.69	-19.69
13.600 G	19.100 G	1.00 M	15.189500 G	-23.92	-10.92

Date: 6.MAY.2015 15:02:08



<b>Band :</b>	WCDMA Band II	<b>Channel :</b>	CH9400
<b>Test Mode :</b>	RMC 12.2Kbps Link (QPSK)	<b>Frequency :</b>	1880.0 MHz

Conducted Spurious Emission Plot between 30MHz ~ 19.1GHz

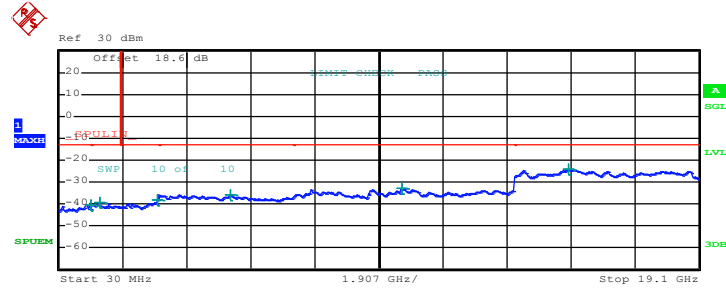

Start [Hz]	Stop [Hz]	RBW [Hz]	Freq [Hz]	PwrAbs [dBm]	Δ Limit [dB]
30.000 M	1.000 G	1.00 M	993.695000 M	-40.43	-27.43
1.000 G	1.845 G	1.00 M	1.237867 G	-39.25	-26.25
1.915 G	3.000 G	1.00 M	2.980741 G	-38.32	-25.32
3.000 G	7.000 G	1.00 M	5.157000 G	-35.96	-22.96
7.000 G	13.600 G	1.00 M	10.246375 G	-32.90	-19.90
13.600 G	19.100 G	1.00 M	15.204625 G	-24.08	-11.08

Date: 6.MAY.2015 15:02:33



Band :	WCDMA Band II	Channel :	CH9538
Test Mode :	RMC 12.2Kbps Link (QPSK)	Frequency :	1907.6 MHz

Conducted Spurious Emission Plot between 30MHz ~ 19.1GHz

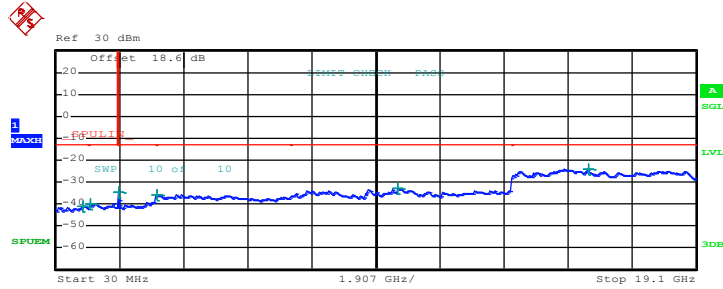

Start [Hz]	Stop [Hz]	RBW [Hz]	Freq [Hz]	PwrAbs [dBm]	Δ Limit [dB]
30.000 M	1.000 G	1.00 M	845.527500 M	-40.77	-27.77
1.000 G	1.845 G	1.00 M	1.065276 G	-39.82	-26.82
1.915 G	3.000 G	1.00 M	1.916627 G	-34.85	-21.85
3.000 G	7.000 G	1.00 M	3.054000 G	-35.82	-22.82
7.000 G	13.600 G	1.00 M	10.212550 G	-33.15	-20.15
13.600 G	19.100 G	1.00 M	15.885938 G	-24.32	-11.32

Date: 6.MAY.2015 15:02:58



### 3.7 Field Strength of Spurious Radiation Measurement

#### 3.7.1 Description of Field Strength of Spurious Radiated Measurement

The power of any emission outside of the authorized operating frequency ranges must be attenuated below the transmitter power (P) by a factor of at least  $43 + 10 \log (P)$  dB. The spectrum is scanned from 30 MHz up to a frequency including its 10th harmonic.

#### 3.7.2 Measuring Instruments

The measuring equipment is listed in the section 4 of this test report.

#### 3.7.3 Test Procedures

1. The testing follows FCC KDB 971168 v02r02 Section 5.8 and ANSI / TIA-603-C-2004 Section 2.2.12.
2. The EUT was placed on a rotatable wooden table 0.8 meters above the ground.
3. The EUT was set 3 meters from the receiving antenna, which was mounted on the antenna tower.
4. The table was rotated 360 degrees to determine the position of the highest spurious emission.
5. The height of the receiving antenna is varied between one meter and four meters to search for the maximum spurious emission for both horizontal and vertical polarizations.
6. Make the measurement with the spectrum analyzer's RBW = 1MHz, VBW = 3MHz, taking record of maximum spurious emission.
7. A horn antenna was substituted in place of the EUT and was driven by a signal generator.
8. Tune the output power of signal generator to the same emission level with EUT maximum spurious emission.
9. Taking the record of output power at antenna port.
10. Repeat step 7 to step 8 for another polarization.
11.  $EIRP \text{ (dBm)} = S.G. \text{ Power} - Tx \text{ Cable Loss} + Tx \text{ Antenna Gain}$
12.  $ERP \text{ (dBm)} = EIRP - 2.15$
13. The RF fundamental frequency should be excluded against the limit line in the operating frequency band.
14. The limit line is derived from  $43 + 10\log(P)$  dB below the transmitter power P(Watts)  
 $= P(W) - [43 + 10\log(P)] \text{ (dB)}$   
 $= [30 + 10\log(P)] \text{ (dBm)} - [43 + 10\log(P)] \text{ (dB)}$   
 $= -13dBm.$

### 3.7.4 Test Setup

For radiated emissions from 30MHz to 1GHz

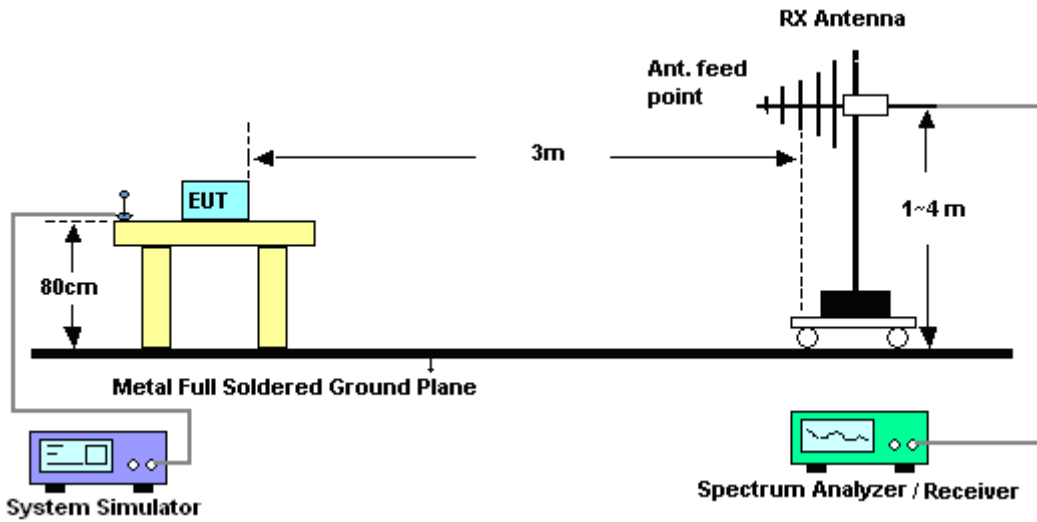

For radiated emissions above 1GHz

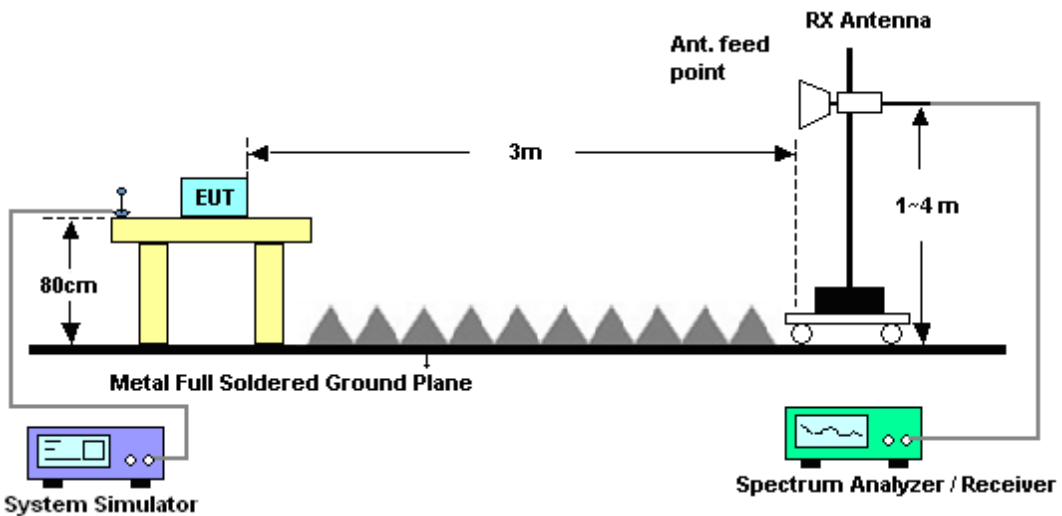



### 3.7.5 Test Result of Field Strength of Spurious Radiated

<Low Channel>

<b>Band :</b>	WCDMA Band V		<b>Temperature :</b>	21~24°C					
<b>Test Mode :</b>	RMC 12.2Kbps Link (QPSK)		<b>Relative Humidity :</b>	52~55%					
<b>Test Engineer :</b>	Nick Yu and Ken Wu		<b>Polarization :</b>	Horizontal					
<b>Remark :</b>	Spurious emissions within 30-1000MHz were found more than 20dB below limit line.								
Frequency ( MHz )	ERP ( dBm )	Limit ( dBm )	Over Limit ( dB )	SPA Reading ( dBm )	S.G. Power ( dBm )	TX Cable loss ( dB )	TX Antenna Gain ( dBi )	Polarization ( H/V )	Result
1653	-64.16	-13	-51.16	-75.51	-65.9	0.98	4.87	H	Pass
2479	-60.00	-13	-47.00	-76.35	-61.9	1.28	5.34	H	Pass
3305	-59.15	-13	-46.15	-77.05	-62.6	1.54	7.14	H	Pass

<b>Band :</b>	WCDMA Band V		<b>Temperature :</b>	21~24°C					
<b>Test Mode :</b>	RMC 12.2Kbps Link (QPSK)		<b>Relative Humidity :</b>	52~55%					
<b>Test Engineer :</b>	Nick Yu and Ken Wu		<b>Polarization :</b>	Vertical					
<b>Remark :</b>	Spurious emissions within 30-1000MHz were found more than 20dB below limit line.								
Frequency ( MHz )	ERP ( dBm )	Limit ( dBm )	Over Limit ( dB )	SPA Reading ( dBm )	S.G. Power ( dBm )	TX Cable loss ( dB )	TX Antenna Gain ( dBi )	Polarization ( H/V )	Result
1653	-63.56	-13	-50.56	-75.45	-65.3	0.98	4.87	V	Pass
2479	-58.40	-13	-45.40	-76.28	-60.3	1.28	5.34	V	Pass
3305	-57.95	-13	-44.95	-77.07	-61.4	1.54	7.14	V	Pass



<Middle Channel>

<b>Band :</b>	WCDMA Band V	<b>Temperature :</b>	21~24°C						
<b>Test Mode :</b>	RMC 12.2Kbps Link (QPSK)	<b>Relative Humidity :</b>	52~55%						
<b>Test Engineer :</b>	Nick Yu and Ken Wu	<b>Polarization :</b>	Horizontal						
<b>Remark :</b>	Spurious emissions within 30-1000MHz were found more than 20dB below limit line.								
Frequency ( MHz )	ERP ( dBm )	Limit ( dBm )	Over Limit ( dB )	SPA Reading ( dBm )	S.G. Power ( dBm )	TX Cable loss ( dB )	TX Antenna Gain ( dBi )	Polarization ( H/V )	Result
1673	-63.92	-13	-50.92	-75.15	-65.6	0.99	4.82	H	Pass
2509	-60.24	-13	-47.24	-76.56	-62.2	1.29	5.41	H	Pass
3345	-59.49	-13	-46.49	-76.67	-63.1	1.56	7.32	H	Pass

<b>Band :</b>	WCDMA Band V	<b>Temperature :</b>	21~24°C						
<b>Test Mode :</b>	RMC 12.2Kbps Link (QPSK)	<b>Relative Humidity :</b>	52~55%						
<b>Test Engineer :</b>	Nick Yu and Ken Wu	<b>Polarization :</b>	Vertical						
<b>Remark :</b>	Spurious emissions within 30-1000MHz were found more than 20dB below limit line.								
Frequency ( MHz )	ERP ( dBm )	Limit ( dBm )	Over Limit ( dB )	SPA Reading ( dBm )	S.G. Power ( dBm )	TX Cable loss ( dB )	TX Antenna Gain ( dBi )	Polarization ( H/V )	Result
1673	-61.92	-13	-48.92	-73.55	-63.6	0.99	4.82	V	Pass
2509	-58.44	-13	-45.44	-76.29	-60.4	1.29	5.41	V	Pass
3345	-58.49	-13	-45.49	-77.14	-62.1	1.56	7.32	V	Pass



<High Channel>

<b>Band :</b>	WCDMA Band V				<b>Temperature :</b>	21~24°C			
<b>Test Mode :</b>	RMC 12.2Kbps Link (QPSK)				<b>Relative Humidity :</b>	52~55%			
<b>Test Engineer :</b>	Nick Yu and Ken Wu				<b>Polarization :</b>	Horizontal			
<b>Remark :</b>	Spurious emissions within 30-1000MHz were found more than 20dB below limit line.								
Frequency ( MHz )	ERP ( dBm )	Limit ( dBm )	Over Limit ( dB )	SPA Reading ( dBm )	S.G. Power ( dBm )	TX Cable loss ( dB )	TX Antenna Gain ( dBi )	Polarization ( H/V )	Result
1696	-63.50	-13	-50.50	-75.37	-65.1	1.00	4.75	H	Pass
2540	-59.92	-13	-46.92	-76.51	-61.9	1.30	5.43	H	Pass
3386	-59.02	-13	-46.02	-76.66	-62.8	1.57	7.50	H	Pass

<b>Band :</b>	WCDMA Band V				<b>Temperature :</b>	21~24°C			
<b>Test Mode :</b>	RMC 12.2Kbps Link (QPSK)				<b>Relative Humidity :</b>	52~55%			
<b>Test Engineer :</b>	Nick Yu and Ken Wu				<b>Polarization :</b>	Vertical			
<b>Remark :</b>	Spurious emissions within 30-1000MHz were found more than 20dB below limit line.								
Frequency ( MHz )	ERP ( dBm )	Limit ( dBm )	Over Limit ( dB )	SPA Reading ( dBm )	S.G. Power ( dBm )	TX Cable loss ( dB )	TX Antenna Gain ( dBi )	Polarization ( H/V )	Result
1696	-61.60	-13	-48.60	-73.99	-63.2	1.00	4.75	V	Pass
2540	-58.52	-13	-45.52	-76.75	-60.5	1.30	5.43	V	Pass
3386	-58.32	-13	-45.32	-77.07	-62.1	1.57	7.50	V	Pass



<Low Channel>

<b>Band :</b>	WCDMA Band II	<b>Temperature :</b>	21~24°C						
<b>Test Mode :</b>	RMC 12.2Kbps Link (QPSK)	<b>Relative Humidity :</b>	52~55%						
<b>Test Engineer :</b>	Nick Yu and Ken Wu	<b>Polarization :</b>	Horizontal						
<b>Remark :</b>	Spurious emissions within 30-1000MHz were found more than 20dB below limit line.								
Frequency ( MHz )	EIRP ( dBm )	Limit ( dBm )	Over Limit ( dB )	SPA Reading ( dBm )	S.G. Power ( dBm )	TX Cable loss ( dB )	TX Antenna Gain ( dBi )	Polarization ( H/V )	Result
3707	-51.52	-13	-38.52	-70.72	-58.1	1.67	8.25	H	Pass
5557	-52.54	-13	-39.54	-77.07	-59.6	2.66	9.72	H	Pass
7410	-52.84	-13	-39.84	-79.32	-62	2.46	11.62	H	Pass

<b>Band :</b>	WCDMA Band II	<b>Temperature :</b>	21~24°C						
<b>Test Mode :</b>	RMC 12.2Kbps Link (QPSK)	<b>Relative Humidity :</b>	52~55%						
<b>Test Engineer :</b>	Nick Yu and Ken Wu	<b>Polarization :</b>	Vertical						
<b>Remark :</b>	Spurious emissions within 30-1000MHz were found more than 20dB below limit line.								
Frequency ( MHz )	EIRP ( dBm )	Limit ( dBm )	Over Limit ( dB )	SPA Reading ( dBm )	S.G. Power ( dBm )	TX Cable loss ( dB )	TX Antenna Gain ( dBi )	Polarization ( H/V )	Result
3707	-50.22	-13	-37.22	-70.54	-56.8	1.67	8.25	V	Pass
5555	-51.33	-13	-38.33	-77	-58.4	2.66	9.72	V	Pass
7410	-50.74	-13	-37.74	-78.99	-59.9	2.46	11.62	V	Pass



<Middle Channel>

<b>Band :</b>	WCDMA Band II	<b>Temperature :</b>	21~24°C						
<b>Test Mode :</b>	RMC 12.2Kbps Link (QPSK)	<b>Relative Humidity :</b>	52~55%						
<b>Test Engineer :</b>	Nick Yu and Ken Wu	<b>Polarization :</b>	Horizontal						
<b>Remark :</b>	Spurious emissions within 30-1000MHz were found more than 20dB below limit line.								
Frequency ( MHz )	EIRP ( dBm )	Limit ( dBm )	Over Limit ( dB )	SPA Reading ( dBm )	S.G. Power ( dBm )	TX Cable loss ( dB )	TX Antenna Gain ( dBi )	Polarization ( H/V )	Result
3763	-52.87	-13	-39.87	-72.66	-59.5	1.69	8.32	H	Pass
5639	-52.05	-13	-39.05	-76.77	-59.1	2.71	9.76	H	Pass
7520	-52.01	-13	-39.01	-79.05	-61.4	2.42	11.81	H	Pass

<b>Band :</b>	WCDMA Band II	<b>Temperature :</b>	21~24°C						
<b>Test Mode :</b>	RMC 12.2Kbps Link (QPSK)	<b>Relative Humidity :</b>	52~55%						
<b>Test Engineer :</b>	Nick Yu and Ken Wu	<b>Polarization :</b>	Vertical						
<b>Remark :</b>	Spurious emissions within 30-1000MHz were found more than 20dB below limit line.								
Frequency ( MHz )	EIRP ( dBm )	Limit ( dBm )	Over Limit ( dB )	SPA Reading ( dBm )	S.G. Power ( dBm )	TX Cable loss ( dB )	TX Antenna Gain ( dBi )	Polarization ( H/V )	Result
3763	-52.57	-13	-39.57	-73.21	-59.2	1.69	8.32	V	Pass
5639	-51.35	-13	-38.35	-76.84	-58.4	2.71	9.76	V	Pass
7520	-50.81	-13	-37.81	-79.26	-60.2	2.42	11.81	V	Pass



<High Channel>

<b>Band :</b>	WCDMA Band II	<b>Temperature :</b>	21~24°C						
<b>Test Mode :</b>	RMC 12.2Kbps Link (QPSK)	<b>Relative Humidity :</b>	52~55%						
<b>Test Engineer :</b>	Nick Yu and Ken Wu	<b>Polarization :</b>	Horizontal						
<b>Remark :</b>	Spurious emissions within 30-1000MHz were found more than 20dB below limit line.								
Frequency ( MHz )	EIRP ( dBm )	Limit ( dBm )	Over Limit ( dB )	SPA Reading ( dBm )	S.G. Power ( dBm )	TX Cable loss ( dB )	TX Antenna Gain ( dBi )	Polarization ( H/V )	Result
3819	-53.02	-13	-40.02	-73.84	-59.7	1.70	8.38	H	Pass
5723	-52.26	-13	-39.26	-77.02	-59.3	2.75	9.79	H	Pass
7635	-51.60	-13	-38.60	-79.12	-61.1	2.39	11.88	H	Pass

<b>Band :</b>	WCDMA Band II	<b>Temperature :</b>	21~24°C						
<b>Test Mode :</b>	RMC 12.2Kbps Link (QPSK)	<b>Relative Humidity :</b>	52~55%						
<b>Test Engineer :</b>	Nick Yu and Ken Wu	<b>Polarization :</b>	Vertical						
<b>Remark :</b>	Spurious emissions within 30-1000MHz were found more than 20dB below limit line.								
Frequency ( MHz )	EIRP ( dBm )	Limit ( dBm )	Over Limit ( dB )	SPA Reading ( dBm )	S.G. Power ( dBm )	TX Cable loss ( dB )	TX Antenna Gain ( dBi )	Polarization ( H/V )	Result
3819	-53.62	-13	-40.62	-74.51	-60.3	1.70	8.38	V	Pass
5723	-51.56	-13	-38.56	-77.56	-58.6	2.75	9.79	V	Pass
7635	-50.00	-13	-37.00	-79.08	-59.5	2.39	11.88	V	Pass



<Low Channel>

<b>Band :</b>	WCDMA Band IV				<b>Temperature :</b>	21~24°C			
<b>Test Mode :</b>	RMC 12.2Kbps Link (QPSK)				<b>Relative Humidity :</b>	52~55%			
<b>Test Engineer :</b>	Nick Yu and Ken Wu				<b>Polarization :</b>	Horizontal			
<b>Remark :</b>	Spurious emissions within 30-1000MHz were found more than 20dB below limit line.								
Frequency ( MHz )	EIRP ( dBm )	Limit ( dBm )	Over Limit ( dB )	SPA Reading ( dBm )	S.G. Power ( dBm )	TX Cable loss ( dB )	TX Antenna Gain ( dBi )	Polarization ( H/V )	Result
3425	-58.21	-13	-45.21	-75.9	-64.3	1.58	7.67	H	Pass
5135	-51.81	-13	-38.81	-75.31	-59.1	2.41	9.70	H	Pass
6850	-52.52	-13	-39.52	-78.7	-60.5	2.64	10.62	H	Pass

<b>Band :</b>	WCDMA Band IV				<b>Temperature :</b>	21~24°C			
<b>Test Mode :</b>	RMC 12.2Kbps Link (QPSK)				<b>Relative Humidity :</b>	52~55%			
<b>Test Engineer :</b>	Nick Yu and Ken Wu				<b>Polarization :</b>	Vertical			
<b>Remark :</b>	Spurious emissions within 30-1000MHz were found more than 20dB below limit line.								
Frequency ( MHz )	EIRP ( dBm )	Limit ( dBm )	Over Limit ( dB )	SPA Reading ( dBm )	S.G. Power ( dBm )	TX Cable loss ( dB )	TX Antenna Gain ( dBi )	Polarization ( H/V )	Result
3425	-56.81	-13	-43.81	-75.95	-62.9	1.58	7.67	V	Pass
5135	-48.51	-13	-35.51	-73.1	-55.8	2.41	9.70	V	Pass
6850	-51.12	-13	-38.12	-78.58	-59.1	2.64	10.62	V	Pass



<Middle Channel>

<b>Band :</b>	WCDMA Band IV	<b>Temperature :</b>	21~24°C						
<b>Test Mode :</b>	RMC 12.2Kbps Link (QPSK)	<b>Relative Humidity :</b>	52~55%						
<b>Test Engineer :</b>	Nick Yu and Ken Wu	<b>Polarization :</b>	Horizontal						
<b>Remark :</b>	Spurious emissions within 30-1000MHz were found more than 20dB below limit line.								
Frequency ( MHz )	EIRP ( dBm )	Limit ( dBm )	Over Limit ( dB )	SPA Reading ( dBm )	S.G. Power ( dBm )	TX Cable loss ( dB )	TX Antenna Gain ( dBi )	Polarization ( H/V )	Result
3465	-57.25	-13	-44.25	-74.9	-63.5	1.59	7.85	H	Pass
5198	-52.85	-13	-39.85	-76.06	-60.1	2.45	9.70	H	Pass
6930	-52.20	-13	-39.20	-78.56	-60.3	2.61	10.72	H	Pass

<b>Band :</b>	WCDMA Band IV	<b>Temperature :</b>	21~24°C						
<b>Test Mode :</b>	RMC 12.2Kbps Link (QPSK)	<b>Relative Humidity :</b>	52~55%						
<b>Test Engineer :</b>	Nick Yu and Ken Wu	<b>Polarization :</b>	Vertical						
<b>Remark :</b>	Spurious emissions within 30-1000MHz were found more than 20dB below limit line.								
Frequency ( MHz )	EIRP ( dBm )	Limit ( dBm )	Over Limit ( dB )	SPA Reading ( dBm )	S.G. Power ( dBm )	TX Cable loss ( dB )	TX Antenna Gain ( dBi )	Polarization ( H/V )	Result
3465	-56.35	-13	-43.35	-75.4	-62.6	1.59	7.85	V	Pass
5198	-48.95	-13	-35.95	-73.56	-56.2	2.45	9.70	V	Pass
6930	-51.00	-13	-38.00	-78.45	-59.1	2.61	10.72	V	Pass



<High Channel>

<b>Band :</b>	WCDMA Band IV	<b>Temperature :</b>	21~24°C						
<b>Test Mode :</b>	RMC 12.2Kbps Link (QPSK)	<b>Relative Humidity :</b>	52~55%						
<b>Test Engineer :</b>	Nick Yu and Ken Wu	<b>Polarization :</b>	Horizontal						
<b>Remark :</b>	Spurious emissions within 30-1000MHz were found more than 20dB below limit line.								
Frequency ( MHz )	EIRP ( dBm )	Limit ( dBm )	Over Limit ( dB )	SPA Reading ( dBm )	S.G. Power ( dBm )	TX Cable loss ( dB )	TX Antenna Gain ( dBi )	Polarization ( H/V )	Result
3505	-58.20	-13	-45.20	-75.79	-64.6	1.61	8.01	H	Pass
5254	-52.88	-13	-39.88	-77.23	-60.1	2.48	9.70	H	Pass
7010	-52.47	-13	-39.47	-78.88	-60.7	2.59	10.82	H	Pass

<b>Band :</b>	WCDMA Band IV	<b>Temperature :</b>	21~24°C						
<b>Test Mode :</b>	RMC 12.2Kbps Link (QPSK)	<b>Relative Humidity :</b>	52~55%						
<b>Test Engineer :</b>	Nick Yu and Ken Wu	<b>Polarization :</b>	Vertical						
<b>Remark :</b>	Spurious emissions within 30-1000MHz were found more than 20dB below limit line.								
Frequency ( MHz )	EIRP ( dBm )	Limit ( dBm )	Over Limit ( dB )	SPA Reading ( dBm )	S.G. Power ( dBm )	TX Cable loss ( dB )	TX Antenna Gain ( dBi )	Polarization ( H/V )	Result
3504	-56.80	-13	-43.80	-75.32	-63.2	1.61	8.00	V	Pass
5254	-50.88	-13	-37.88	-75.75	-58.1	2.48	9.70	V	Pass
7010	-51.37	-13	-38.37	-78.68	-59.6	2.59	10.82	V	Pass



### 3.8 Frequency Stability Measurement

#### 3.8.1 Description of Frequency Stability Measurement

The frequency stability shall be measured by variation of ambient temperature and variation of primary supply voltage to ensure that the fundamental emission stays within the authorized frequency block. The frequency stability of the transmitter shall be maintained within  $\pm 0.00025\%$  ( $\pm 2.5\text{ppm}$ ) of the center frequency.

#### 3.8.2 Measuring Instruments

The measuring equipment is listed in the section 4 of this test report.

#### 3.8.3 Test Procedures for Temperature Variation

1. The testing follows FCC KDB 971168 v02r02 Section 9.0.
2. The EUT was set up in the thermal chamber and connected with the system simulator.
3. With power OFF, the temperature was decreased to  $-30^{\circ}\text{C}$  and the EUT was stabilized before testing. Power was applied and the maximum change in frequency was recorded within one minute.
4. With power OFF, the temperature was raised in  $10^{\circ}\text{C}$  steps up to  $50^{\circ}\text{C}$ . The EUT was stabilized at each step for at least half an hour. Power was applied and the maximum frequency change was recorded within one minute.

#### 3.8.4 Test Procedures for Voltage Variation

1. The testing follows FCC KDB 971168 v02r02 Section 9.0.
2. The EUT was placed in a temperature chamber at  $25\pm 5^{\circ}\text{C}$  and connected with the system simulator.
3. The power supply voltage to the EUT was varied from BEP to 115% of the nominal value measured at the input to the EUT.
4. The variation in frequency was measured for the worst case.

### 3.8.5 Test Setup

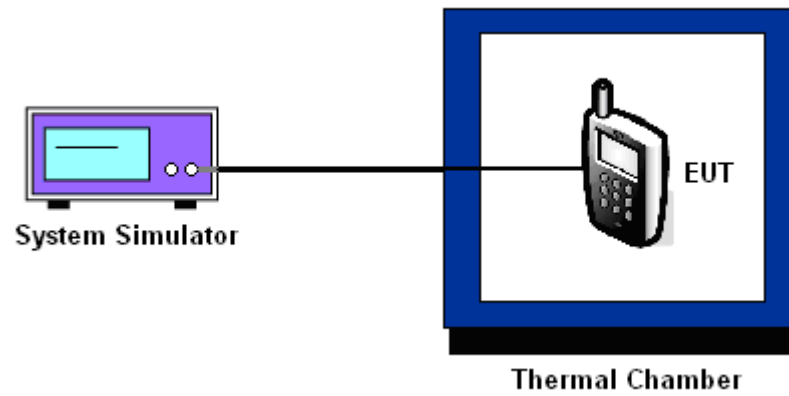



3.8.6 Test Result of Temperature Variation

<b>Band :</b>	WCDMA Band V	<b>Channel :</b>	4182
<b>Limit (ppm) :</b>	2.5	<b>Frequency :</b>	836.4 MHz

Temperature (°C)	RMC 12.2Kbps	Result
	Deviation (ppm)	
50	0.0024	PASS
40	0.0000	
30	0.0012	
20(Ref.)	0.0000	
10	0.0000	
0	0.0132	
-10	0.0012	
-20	0.0000	
-30	0.0012	

<b>Band :</b>	WCDMA Band IV	<b>Channel :</b>	1413
<b>Limit (ppm) :</b>	within authorized band	<b>Frequency :</b>	1732.6 MHz

Temperature (°C)	RMC 12.2Kbps	Result
	Deviation (ppm)	
50	0.0098	PASS
40	0.0063	
30	0.0012	
20(Ref.)	0.0000	
10	0.0000	
0	0.0029	
-10	0.0006	
-20	0.0012	
-30	0.0012	

Note: The frequency fundamental emissions stay within the authorized frequency block based on the frequency deviation measured is small.



<b>Band :</b>	WCDMA Band II	<b>Channel :</b>	9400
<b>Limit (ppm) :</b>	within authorized band	<b>Frequency :</b>	1880.0 MHz

Temperature (°C)	RMC 12.2Kbps	Result
	Deviation (ppm)	
50	0.0005	PASS
40	0.0005	
30	0.0011	
20(Ref.)	0.0000	
10	0.0005	
0	0.0005	
-10	0.0005	
-20	0.0011	
-30	0.0005	

Note: The frequency fundamental emissions stay within the authorized frequency block based on the frequency deviation measured is small.



3.8.7 Test Result of Voltage Variation

Band & Channel	Mode	Voltage (Volt)	Deviation (ppm)	Limit (ppm)	Result
WCDMA Band V CH4182	RMC 12.2Kbps	4.35	0.0012	2.5	PASS
		3.95	0.0108		
		BEP	0.0024		
WCDMA Band IV CH1413	RMC 12.2Kbps	4.35	0.0242	(Note 3.)	
		3.95	0.0231		
		BEP	0.0231		
WCDMA Band II CH9400	RMC 12.2Kbps	4.35	0.0005	(Note 3.)	
		3.95	0.0005		
		BEP	0.0011		

Note:

- 1. Normal Voltage = 3.95V.
- 2. Battery End Point (BEP) = 3.55 V.
- 3. The frequency fundamental emissions stay within the authorized frequency block based on the frequency deviation measured is small.



## 4 List of Measuring Equipment

Instrument	Manufacturer	Model No.	Serial No.	Characteristics	Calibration Date	Test Date	Due Date	Remark
Spectrum Analyzer	Rohde & Schwarz	FSP30	101329	9kHz~30GHz	Jun. 14, 2014	May 06, 2015~ Jun. 03, 2015	Jun. 13, 2015	Conducted (TH02-HY)
Signal Generator	Rohde & Schwarz	SMU200A	102502	9kHz~6GHz	Jul. 07, 2014	May 06, 2015~ Jun. 03, 2015	Jul. 06, 2015	Conducted (TH02-HY)
Temperature Chamber	ESPEC	SU-641	92013721	-30°C~70°C	Dec. 01, 2014	May 06, 2015~ Jun. 03, 2015	Nov. 30, 2015	Conducted (TH02-HY)
Bilog Antenna	Schaffner	CBL6111C	2726	30MHz ~ 1GHz	Sep. 27, 2014	May 16, 2015 ~ Jun. 15, 2015	Sep. 26, 2015	Radiation (03CH07-HY)
Double Ridge Horn Antenna	ESCO	3117	00075962	1GHz ~ 18GHz	Aug. 19, 2014	May 16, 2015 ~ Jun. 15, 2015	Aug. 18, 2015	Radiation (03CH07-HY)
Horn Antenna	SCHWARZBECK	BBHA 9120D	9120D-1328	1GHz ~ 18GHz	Nov. 05, 2014	May 16, 2015 ~ Jun. 15, 2015	Nov. 04, 2015	Radiation (03CH07-HY)
Preamplifier	COM-POWER	PA-103A	161241	10MHz-1000MHz	Mar. 12, 2015	May 16, 2015 ~ Jun. 15, 2015	Mar. 11, 2016	Radiation (03CH07-HY)
Preamplifier	Agilent	8449B	3008A02362	1GHz~ 26.5GHz	Oct. 21, 2014	May 16, 2015 ~ Jun. 15, 2015	Oct. 20, 2015	Radiation (03CH07-HY)
Signal Analyzer	Rohde & Schwarz	FSV 30	101749	10Hz~30GHz	Mar. 10, 2015	May 16, 2015 ~ Jun. 15, 2015	Mar. 09, 2016	Radiation (03CH07-HY)
Antenna Mast	Max-Full	MFA520BS	N/A	1m~4m	N/A	May 16, 2015 ~ Jun. 15, 2015	N/A	Radiation (03CH07-HY)
Turn Table	ChainTek	Chaintek 3000	N/A	0~360 degree	N/A	May 16, 2015 ~ Jun. 15, 2015	N/A	Radiation (03CH07-HY)
Signal Generator	Rohde & Schwarz	SMF100A	101107	100kHz~40GHz	May 23, 2014	May 16, 2015 ~ May 17, 2015	May 22, 2015	Radiation (03CH07-HY)
Signal Generator	Rohde & Schwarz	SMF100A	101107	100kHz~40GHz	May 22, 2015	Jun. 15, 2015	May 21, 2016	Radiation (03CH07-HY)
SHF-EHF Horn Antenna	SCHWARZBECK	BBHA 9170	BBHA9170251	18GHz~40GHz	Oct. 02, 2014	May 16, 2015 ~ Jun. 15, 2015	Oct. 01, 2015	Radiation (03CH07-HY)



## 5 Uncertainty of Evaluation

### Uncertainty of Radiated Emission Measurement (30 MHz ~ 1000 MHz)

Measuring Uncertainty for a Level of Confidence of 95% ( $U = 2Uc(y)$ )	4.50
---	------



## **Appendix A. Original Report**

Please refer to Sporton report number FG542019-04A as below.



# FCC RF Test Report

**APPLICANT** : Motorola Mobility, LLC  
**EQUIPMENT** : Mobile Cellular Phone  
**BRAND NAME** : Motorola  
**MODEL NAME** : 4595  
**FCC ID** : IHDT56QG2  
**STANDARD** : FCC 47 CFR Part 2, 22(H), 24(E), 27(L)  
**CLASSIFICATION** : PCS Licensed Transmitter Held to Ear (PCE)

The product was received on Apr. 20, 2015. We, SPORTON INTERNATIONAL INC., would like to declare that the tested sample has been evaluated in accordance with the test procedures given in ANSI / TIA / EIA-603-C-2004 and has been in compliance with the applicable technical standards.

The test results in this report apply exclusively to the tested model / sample. Without written approval of SPORTON INTERNATIONAL INC., the test report shall not be reproduced except in full.

Reviewed by: Joseph Lin / Supervisor

Approved by: Jones Tsai / Manager



## SPORTON INTERNATIONAL INC.

No. 52, Hwa Ya 1<sup>st</sup> Rd., Hwa Ya Technology Park, Kwei-Shan Hsiang, Tao Yuan Hsien, Taiwan, R.O.C.



# TABLE OF CONTENTS

**1 GENERAL DESCRIPTION ..... 4**

1.1. Applicant..... 4

1.2. Manufacturer ..... 4

1.3. Product Feature of Equipment Under Test ..... 4

1.4. Product Specification subjective to this standard ..... 5

1.5. Modification of EUT ..... 5

## APPENDIX A. ORIGINAL REPORT





# 1 General Description

## 1.1. Applicant

**Motorola Mobility, LLC**

222 W Merchandise Mart Plaza, Suite 1800, Chicago, IL 60654, United States

## 1.2. Manufacturer

**Motorola Mobility, LLC**

222 W Merchandise Mart Plaza, Suite 1800, Chicago, IL 60654, United States

## 1.3. Product Feature of Equipment Under Test

Product Feature	
Equipment	Mobile Cellular Phone
Brand Name	Motorola
Model Name	4595
FCC ID	IHDT56QG2
EUT supports Radios application	GSM/EGPRS/WCDMA/HSPA/LTE WLAN 11b/g/n HT20 Bluetooth v3.0 EDR Bluetooth v4.0 - LE
HW Version	P2B
EUT Stage	Identical Prototype

**Remark:** The above EUT's information was declared by manufacturer. Please refer to the specifications or user's manual for more detailed description.



### 1.4. Product Specification subjective to this standard

Product Specification subjective to this standard	
<b>Tx Frequency</b>	GSM850: 824.2 MHz ~ 848.8 MHz GSM1900: 1850.2 MHz ~ 1909.8MHz WCDMA Band V: 826.4 MHz ~ 846.6 MHz WCDMA Band IV : 1712.4 MHz ~ 1752.6 MHz WCDMA Band II: 1852.4 MHz ~ 1907.6 MHz
<b>Rx Frequency</b>	GSM850: 869.2 MHz ~ 893.8 MHz GSM1900: 1930.2 MHz ~ 1989.8 MHz WCDMA Band V: 871.4 MHz ~ 891.6 MHz WCDMA Band IV : 2112.4 MHz ~ 2152.6 MHz WCDMA Band II: 1932.4 MHz ~ 1987.6 MHz
<b>Antenna Type</b>	Fixed Internal Antenna
<b>Type of Modulation</b>	GSM: GMSK GPRS: GMSK EDGE: GMSK / 8PSK WCDMA: QPSK (Uplink) HSDPA: 64QAM (Downlink) HSUPA: QPSK (Uplink)

### 1.5. Modification of EUT

No modifications are made to the EUT during all test items.



## **Appendix A. Original Report**

Please refer to Sporton report number FG542019-01A as below.



# FCC RF Test Report

**APPLICANT** : Motorola Mobility, LLC  
**EQUIPMENT** : Mobile Cellular Phone  
**BRAND NAME** : Motorola  
**MODEL NAME** : 4597  
**FCC ID** : IHDT56QG2  
**STANDARD** : FCC 47 CFR Part 2, 22(H), 24(E), 27(L)  
**CLASSIFICATION** : PCS Licensed Transmitter Held to Ear (PCE)

The product was received on Apr. 20, 2015 and testing was completed on May 12, 2015. We, SPORTON INTERNATIONAL INC., would like to declare that the tested sample has been evaluated in accordance with the test procedures given in ANSI / TIA / EIA-603-C-2004 and has been in compliance with the applicable technical standards.

The test results in this report apply exclusively to the tested model / sample. Without written approval of SPORTON INTERNATIONAL INC., the test report shall not be reproduced except in full.

Reviewed by: Joseph Lin / Supervisor

Approved by: Jones Tsai / Manager



## SPORTON INTERNATIONAL INC.

No. 52, Hwa Ya 1<sup>st</sup> Rd., Hwa Ya Technology Park, Kwei-Shan District, Tao Yuan City, Taiwan, R.O.C.



# TABLE OF CONTENTS

**REVISION HISTORY..... 3**

**SUMMARY OF TEST RESULT ..... 4**

**1 GENERAL DESCRIPTION ..... 5**

    1.1 Applicant..... 5

    1.2 Manufacturer ..... 5

    1.3 Product Feature of Equipment Under Test ..... 5

    1.4 Product Specification subjective to this standard ..... 6

    1.5 Modification of EUT ..... 6

    1.6 Maximum ERP/EIRP Power, Frequency Tolerance, and Emission Designator ..... 7

    1.7 Testing Location ..... 7

    1.8 Applicable Standards ..... 8

**2 TEST CONFIGURATION OF EQUIPMENT UNDER TEST ..... 9**

    2.1 Test Mode..... 9

    2.2 Connection Diagram of Test System ..... 11

    2.3 Support Unit used in test configuration ..... 11

    2.4 Measurement Results Explanation Example ..... 11

**3 TEST RESULT ..... 12**

    3.1 Conducted Output Power Measurement..... 12

    3.2 Peak-to-Average Ratio ..... 14

    3.3 Effective Radiated Power and Effective Isotropic Radiated Power Measurement ..... 30

    3.4 99% Occupied Bandwidth and 26dB Bandwidth Measurement..... 34

    3.5 Band Edge Measurement..... 58

    3.6 Conducted Spurious Emission Measurement ..... 66

    3.7 Field Strength of Spurious Radiation Measurement ..... 88

    3.8 Frequency Stability Measurement..... 111

**4 LIST OF MEASURING EQUIPMENT ..... 117**

**5 UNCERTAINTY OF EVALUATION ..... 118**





## SUMMARY OF TEST RESULT

Report Section	FCC Rule	Description	Limit	Result	Remark
3.1	§2.1046	Conducted Output Power	Reporting Only	PASS	-
3.2	§24.232(d)	Peak-to-Average Ratio	<13 dB	PASS	-
3.3	§22.913(a)(2)	Effective Radiated Power	< 7 Watts	PASS	-
	§24.232(c)	Equivalent Isotropic Radiated Power	< 2 Watts	PASS	-
	§27.50(d)(4)	Equivalent Isotropic Radiated Power	< 1 Watts	PASS	-
3.4	§2.1049	Occupied Bandwidth	Reporting Only	PASS	-
3.5	§2.1051 §22.917(a) §24.238(a) §27.53(h)	Band Edge Measurement	< 43+10log <sub>10</sub> (P[Watts])	PASS	-
3.6	§2.1051 §22.917(a) §24.238(a) §27.53(h)	Conducted Spurious Emission	< 43+10log <sub>10</sub> (P[Watts])	PASS	-
3.7	§2.1053 §22.917(a) §24.238(a)	Field Strength of Spurious Radiation	< 43+10log <sub>10</sub> (P[Watts])	PASS	Under limit 25.85 dB at 5548.000 MHz
3.8	§2.1055 §22.355	Frequency Stability for Temperature & Voltage	< 2.5 ppm for Part 22 Within Authorized Band	PASS	-
	§2.1055 §24.235 §27.53(h)				



# 1 General Description

## 1.1 Applicant

**Motorola Mobility, LLC**

222 W Merchandise Mart Plaza, Suite 1800, Chicago, IL 60654, United States

## 1.2 Manufacturer

**Motorola Mobility, LLC**

222 W Merchandise Mart Plaza, Suite 1800, Chicago, IL 60654, United States

## 1.3 Product Feature of Equipment Under Test

Product Feature	
Equipment	Mobile Cellular Phone
Brand Name	Motorola
Model Name	4597
FCC ID	IHDT56QG2
IMEI Code	355491060004274 (for Radiation test items) 355491060004191 (for Conducted test items)
EUT supports Radios application	GSM/EGPRS/WCDMA/HSPA/LTE WLAN 11b/g/n HT20 Bluetooth v3.0 EDR Bluetooth v4.0 - LE
HW Version	P2B
EUT Stage	Identical Prototype

**Remark:** The above EUT's information was declared by manufacturer. Please refer to the specifications or user's manual for more detailed description.

Accessory List	
AC Adapter	Brand Name : Motorola
	Model Name : SPN5862A
USB Cable	Brand Name : Motorola
	Model Name : SKN6415A
Earphone	Brand Name : Motorola
	Model Name : SJYN1181B
Battery	Brand Name : Motorola
	Model Name : FC40



### 1.4 Product Specification subjective to this standard

Product Specification subjective to this standard	
<b>Tx Frequency</b>	GSM850: 824.2 MHz ~ 848.8 MHz GSM1900: 1850.2 MHz ~ 1909.8MHz WCDMA Band V: 826.4 MHz ~ 846.6 MHz WCDMA Band IV : 1712.4 MHz ~ 1752.6 MHz WCDMA Band II: 1852.4 MHz ~ 1907.6 MHz
<b>Rx Frequency</b>	GSM850: 869.2 MHz ~ 893.8 MHz GSM1900: 1930.2 MHz ~ 1989.8 MHz WCDMA Band V: 871.4 MHz ~ 891.6 MHz WCDMA Band IV : 2112.4 MHz ~ 2152.6 MHz WCDMA Band II: 1932.4 MHz ~ 1987.6 MHz
<b>Maximum Output Power to Antenna</b>	GSM850 : 32.40 dBm GSM1900 : 29.42 dBm WCDMA Band V : 23.37 dBm WCDMA Band IV : 23.44 dBm WCDMA Band II : 23.52 dBm
<b>99% Occupied Bandwidth</b>	GSM850: 0.25MHz GSM1900: 0.25MHz WCDMA Band V: 4.15MHz WCDMA Band IV : 4.18 MHz WCDMA Band II: 4.18MHz
<b>Antenna Type</b>	Fixed Internal Antenna
<b>Type of Modulation</b>	GSM: GMSK GPRS: GMSK EDGE: GMSK / 8PSK WCDMA: QPSK (Uplink) HSDPA: 64QAM (Downlink) HSUPA: QPSK (Uplink)

### 1.5 Modification of EUT

No modifications are made to the EUT during all test items.



### 1.6 Maximum ERP/EIRP Power, Frequency Tolerance, and Emission Designator

FCC Rule	System	Type of Modulation	Maximum ERP/EIRP (W)	Frequency Tolerance (ppm)	Emission Designator
Part 22	GSM850 GSM	GMSK	0.7534	0.0335 ppm	246KGXW
Part 22	GSM850 EDGE class 8	8PSK	0.1585	0.0072 ppm	241KG7W
Part 22	WCDMA Band V RMC 12.2Kbps	QPSK	0.1125	0.0179 ppm	4M15F9W
Part 24	GSM1900 GSM	GMSK	1.3243	0.0271 ppm	247KGXW
Part 24	GSM1900 EDGE class 8	8PSK	0.4624	0.0048 ppm	245KG7W
Part 24	WCDMA Band II RMC 12.2Kbps	QPSK	0.2529	0.0553 ppm	4M18F9W
Part 27	WCDMA Band IV RMC 12.2Kbps	QPSK	0.2371	0.0115 ppm	4M18F9W

### 1.7 Testing Location

Sporton Lab is accredited to ISO 17025 by Taiwan Accreditation Foundation (TAF code : 1190) and the FCC designation No. TW1022 under the FCC 2.948(e) by Mutual Recognition Agreement (MRA) in FCC Test.

<b>Test Site</b>	SPORTON INTERNATIONAL INC.
<b>Test Site Location</b>	No. 52, Hwa Ya 1 <sup>st</sup> Rd., Hwa Ya Technology Park, Kwei-Shan District, Tao Yuan City, Taiwan, R.O.C. TEL: +886-3-327-3456 FAX: +886-3-328-4978
<b>Test Site No.</b>	<b>Sporton Site No.</b> TH02-HY

<b>Test Site</b>	SPORTON INTERNATIONAL INC.
<b>Test Site Location</b>	No.58, Aly. 75, Ln. 564, Wenhua 3rd Rd., Kwei-Shan District, Tao Yuan City, Taiwan, R.O.C. TEL: +886-3-327-0855
<b>Test Site No.</b>	<b>Sporton Site No.</b> 03CH11-HY



## 1.8 Applicable Standards

According to the specifications of the manufacturer, the EUT must comply with the requirements of the following standards:

- ♦ FCC 47 CFR Part 2, 22(H), 24(E), 27(L)
- ♦ ANSI / TIA / EIA-603-C-2004
- ♦ FCC KDB 971168 D01 Power Meas. License Digital Systems v02r02

### **Remark:**

1. All test items were verified and recorded according to the standards and without any deviation during the test.
2. This EUT has also been tested and complied with the requirements of FCC Part 15, Subpart B, recorded in a separate test report.



## 2 Test Configuration of Equipment Under Test

### 2.1 Test Mode

Antenna port conducted and radiated test items were performed according to KDB 971168 D01 Power Meas. License Digital Systems v02r02 with maximum output power.

Radiated measurements were performed with rotating EUT in different three orthogonal test planes to find the maximum emission.

Radiated emissions were investigated as following frequency range:

1. 30 MHz to 9000 MHz for GSM850 and WCDMA Band V.
2. 30 MHz to 18000 MHz for WCDMA Band IV
3. 30 MHz to 19000 MHz for GSM1900 and WCDMA Band II.

All modes and data rates and positions were investigated.

Test modes are chosen to be reported as the worst case configuration below:

Test Modes		
Band	Radiated TCs	Conducted TCs
GSM 850	<ul style="list-style-type: none"> <li>■ GSM Link</li> <li>■ EDGE class 8 Link</li> </ul>	<ul style="list-style-type: none"> <li>■ GSM Link</li> <li>■ EDGE class 8 Link</li> </ul>
GSM 1900	<ul style="list-style-type: none"> <li>■ GSM Link</li> <li>■ EDGE class 8 Link</li> </ul>	<ul style="list-style-type: none"> <li>■ GSM Link</li> <li>■ EDGE class 8 Link</li> </ul>
WCDMA Band V	<ul style="list-style-type: none"> <li>■ RMC 12.2Kbps Link</li> </ul>	<ul style="list-style-type: none"> <li>■ RMC 12.2Kbps Link</li> </ul>
WCDMA Band II	<ul style="list-style-type: none"> <li>■ RMC 12.2Kbps Link</li> </ul>	<ul style="list-style-type: none"> <li>■ RMC 12.2Kbps Link</li> </ul>
WCDMA Band V	<ul style="list-style-type: none"> <li>■ RMC 12.2Kbps Link</li> </ul>	<ul style="list-style-type: none"> <li>■ RMC 12.2Kbps Link</li> </ul>

**Note:** The maximum power levels are chosen to test as the worst case configuration as follows:

GSM multi-slot class 8 mode for GMSK modulation for GSM850,

GSM multi-slot class 8 mode for GMSK modulation for GSM1900,

EDGE multi-slot class 8 mode for 8PSK modulation,

RMC 12.2Kbps mode for WCDMA band V, WCDMA band IV, and WCDMA band II,

only these modes were used for all tests. In addition to above worst-case test, below investigating on all data rates, and all modes are compliance with each FCC test case which has specific test limits. For spurious emissions at antenna port, the EUT was investigated the band edges on low and high channels, and the unwanted spurious emissions on middle channel for all modes, the results are pass, then only the worst-results were reported in the test report. The Radiated Spurious emissions for GSM/GPRS/EGPRS/HSDPA modes were investigated on the middle channel and the passed results were not worse than those data tested from the highest power channels.



Conducted Power Measurement Results:

Conducted Power (*Unit: dBm)						
Band	GSM850			GSM1900		
Channel	128	189	251	512	661	810
Frequency	824.2	836.4	848.8	1850.2	1880.0	1909.8
GSM	32.31	32.36	32.40	29.42	29.01	29.02
GPRS class 8	32.30	32.35	32.39	29.41	29.00	29.01
GPRS class 10	30.64	30.65	30.70	27.79	27.40	27.42
GPRS class 11	28.95	28.98	28.83	25.90	25.44	25.54
GPRS class 12	26.76	26.54	26.45	23.72	23.52	23.55
EGPRS class 8	26.24	26.18	26.06	25.30	25.10	25.15
EGPRS class 10	24.82	24.78	24.71	24.27	23.95	24.02
EGPRS class 11	22.75	22.67	22.53	22.45	22.11	22.17
EGPRS class 12	20.68	20.75	20.62	20.33	20.00	20.08

Conducted Power (*Unit: dBm)						
Band	WCDMA Band V			WCDMA Band II		
Channel	4132	4182	4233	9262	9400	9538
Frequency	826.4	836.4	846.6	1852.4	1880.0	1907.6
RMC 12.2K	23.28	23.37	23.20	23.52	23.37	23.23
HSDPA Subtest-1	21.97	22.41	22.05	22.56	22.50	22.34
HSDPA Subtest-2	21.85	22.20	21.83	22.53	22.41	22.32
HSDPA Subtest-3	21.52	22.01	21.65	22.07	21.95	21.87
HSDPA Subtest-4	21.17	21.68	21.28	22.03	21.92	21.85
HSUPA Subtest-1	21.52	21.57	21.48	22.32	22.16	22.25
HSUPA Subtest-2	21.25	21.22	21.15	21.10	20.98	21.08
HSUPA Subtest-3	20.94	20.90	20.84	20.64	20.53	20.61
HSUPA Subtest-4	21.29	21.27	21.26	21.75	21.61	21.70
HSUPA Subtest-5	22.08	22.49	22.17	22.59	22.48	22.36

Conducted Power (*Unit: dBm)			
Band	WCDMA Band IV		
Channel	1312	1413	1513
Frequency	1712.4	1732.6	1752.6
RMC 12.2K	23.44	23.35	23.42
HSDPA Subtest-1	22.41	22.48	22.45
HSDPA Subtest-2	22.37	22.42	22.40
HSDPA Subtest-3	21.91	21.98	21.95
HSDPA Subtest-4	21.90	21.99	21.93
HSUPA Subtest-1	21.98	21.87	22.03
HSUPA Subtest-2	21.53	21.39	21.45
HSUPA Subtest-3	21.10	21.01	21.06
HSUPA Subtest-4	21.72	21.64	21.68
HSUPA Subtest-5	22.48	22.55	22.55

## 2.2 Connection Diagram of Test System

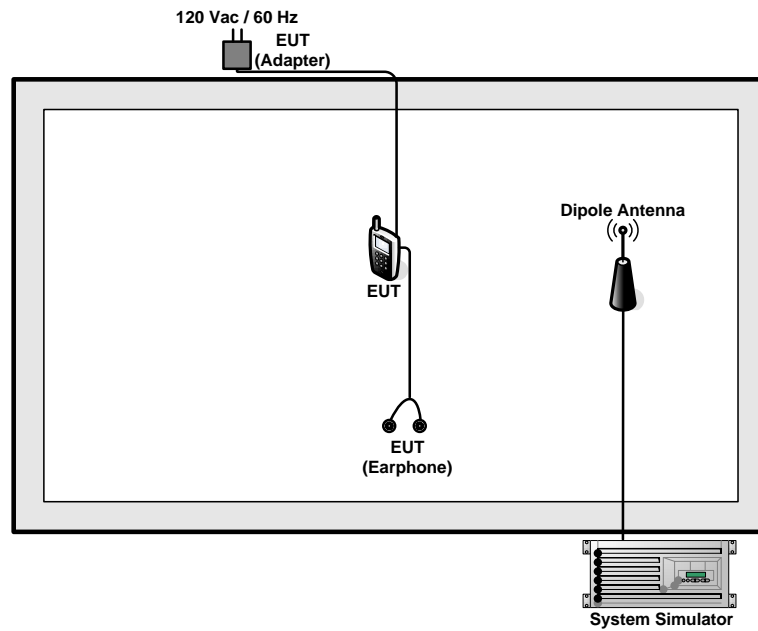

## 2.3 Support Unit used in test configuration

Item	Equipment	Trade Name	Model No.	FCC ID	Data Cable	Power Cord
1.	System Simulator	Anritsu	MT8820C	N/A	N/A	Unshielded, 1.8 m

## 2.4 Measurement Results Explanation Example

For all conducted test items:

The offset level is set in the spectrum analyzer to compensate the RF cable loss and attenuator factor between RF conducted output port and spectrum analyzer. With the offset compensation, the spectrum analyzer reading level will be exactly the RF output level.

The spectrum analyzer offset is derived from RF cable loss and attenuator factor.

$Offset = RF\ cable\ loss + attenuator\ factor.$

The following shows an offset computation example with RF cable loss 4.2 dB and a 10dB attenuator.

Example :

$$\begin{aligned}
 Offset(dB) &= RF\ cable\ loss(dB) + attenuator\ factor(dB). \\
 &= 4.2 + 10 = 14.2\ (dB)
 \end{aligned}$$

### **3 Test Result**

#### **3.1 Conducted Output Power Measurement**

##### **3.1.1 Description of the Conducted Output Power Measurement**

A system simulator was used to establish communication with the EUT. Its parameters were set to enforce EUT transmitting at the maximum power. The measured power in the radio frequency on the transmitter output terminals shall be reported.

##### **3.1.2 Measuring Instruments**

The measuring equipment is listed in the section 4 of this test report.

##### **3.1.3 Test Procedures**

1. The transmitter output port was connected to the system simulator.
2. Set EUT at maximum power through system simulator.
3. Select lowest, middle, and highest channels for each band and different modulation.
4. Measure the maximum burst average power for GSM and maximum average power for other modulation signal.

##### **3.1.4 Test Setup**

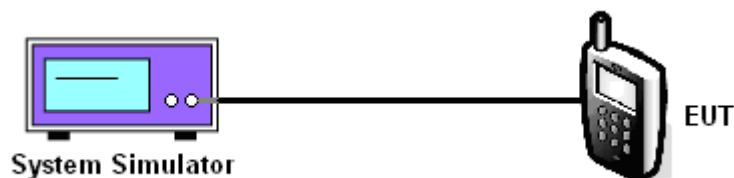



3.1.5 Test Result of Conducted Output Power

Cellular Band									
Modes	GSM850 (GSM)			GSM850 (EDGE class 8)			WCDMA Band V (RMC 12.2Kbps)		
Channel	128 (Low)	189 (Mid)	251 (High)	128 (Low)	189 (Mid)	251 (High)	4132 (Low)	4182 (Mid)	4233 (High)
Frequency (MHz)	824.2	836.4	848.8	824.2	836.4	848.8	826.4	836.4	846.6
Conducted Power (dBm)	32.31	32.36	32.40	26.24	26.18	26.06	23.28	23.37	23.20

PCS Band									
Modes	GSM1900 (GSM)			GSM1900 (EDGE class 8)			WCDMA Band II (RMC 12.2Kbps)		
Channel	512 (Low)	661 (Mid)	810 (High)	512 (Low)	661 (Mid)	810 (High)	9262 (Low)	9400 (Mid)	9538 (High)
Frequency (MHz)	1850.2	1880	1909.8	1850.2	1880	1909.8	1852.4	1880	1907.6
Conducted Power (dBm)	29.42	29.01	29.02	25.30	25.10	25.15	23.52	23.37	23.23

AWS Band			
Modes	WCDMA Band IV (RMC 12.2Kbps)		
Channel	1312(Low)	1413 (Mid)	1513 (High)
Frequency (MHz)	1712.4	1732.6	1752.6
Conducted Power (dBm)	23.44	23.35	23.42

**Note:** maximum burst average power for GSM, and maximum average power for WCDMA .

## 3.2 Peak-to-Average Ratio

### 3.2.1 Description of the PAR Measurement

The peak-to-average ratio (PAR) of the transmission may not exceed 13 dB.

### 3.2.2 Measuring Instruments

The measuring equipment is listed in the section 4 of this test report.

### 3.2.3 Test Procedures

1. The testing follows FCC KDB 971168 v02r02 Section 5.7.1.
2. The EUT was connected to spectrum analyzer and system simulator via a power divider.
3. Set EUT to transmit at maximum output power.
4. When the duty cycle is less than 98%, then signal gating will be implemented on the spectrum analyzer by triggering from the system simulator.
5. Set the CCDF (Complementary Cumulative Distribution Function) option of the spectrum analyzer.
6. Record the maximum PAPR level associated with a probability of 0.1%.

### 3.2.4 Test Setup

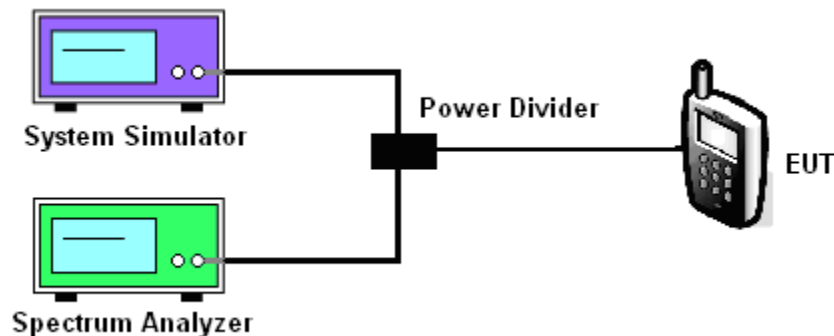



### 3.2.5 Test Result of Peak-to-Average Ratio

Cellular Band									
Modes	GSM850 (GSM)			GSM850 (EDGE class 8)			WCDMA Band V (RMC 12.2Kbps)		
Channel	128 (Low)	189 (Mid)	251 (High)	128 (Low)	189 (Mid)	251 (High)	4132 (Low)	4182 (Mid)	4233 (High)
Frequency (MHz)	824.2	836.4	848.8	824.2	836.4	848.8	826.4	836.4	846.6
Peak-to-Average Ratio (dB)	0.28	0.24	0.28	3.20	3.36	3.20	3.32	3.20	3.24

PCS Band									
Modes	GSM1900 (GSM)			GSM1900 (EDGE class 8)			WCDMA Band II (RMC 12.2Kbps)		
Channel	512 (Low)	661 (Mid)	810 (High)	512 (Low)	661 (Mid)	810 (High)	9262 (Low)	9400 (Mid)	9538 (High)
Frequency (MHz)	1850.2	1880	1909.8	1850.2	1880	1909.8	1852.4	1880	1907.6
Peak-to-Average Ratio (dB)	0.24	0.28	0.28	3.44	3.48	3.52	3.16	3.12	3.12

AWS Band			
Modes	WCDMA Band IV (RMC 12.2Kbps)		
Channel	1312(Low)	1413 (Mid)	1513 (High)
Frequency (MHz)	1712.4	1732.6	1752.6
Peak-to-Average Ratio (dB)	3.08	3.16	2.72



### 3.2.6 Test Result (Plots) of Peak-to-Average Ratio

Band :	GSM 850	Test Mode :	GSM Link (GMSK)
--------	---------	-------------	-----------------

#### Peak-to-Average Ratio on Channel 128 (824.2 MHz)

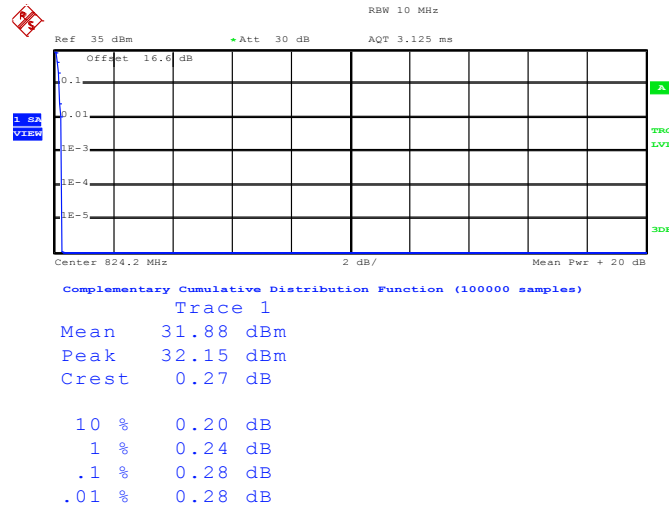

Date: 8.MAY.2015 18:59:18

#### Peak-to-Average Ratio on Channel 189 (836.4 MHz)

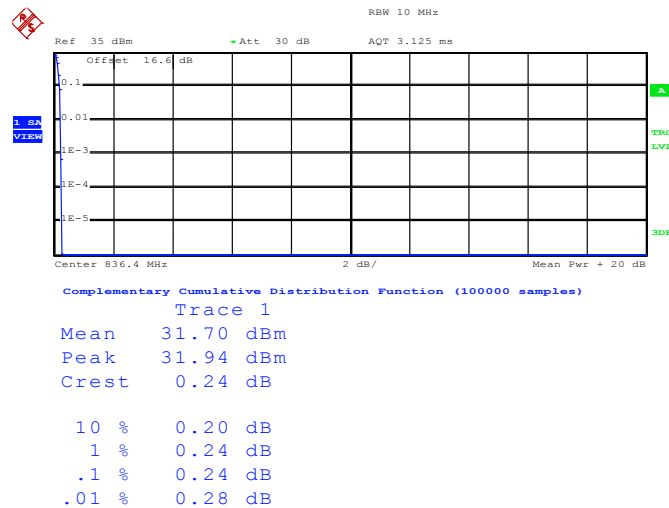

Date: 8.MAY.2015 18:59:28



Peak-to-Average Ratio on Channel 251 (848.8 MHz)

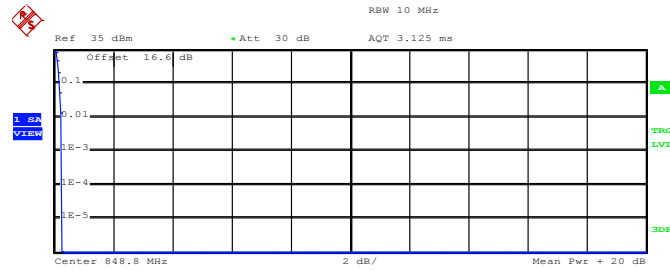

Complementary Cumulative Distribution Function (100000 samples)

Trace 1

Mean	31.89 dBm
Peak	32.15 dBm
Crest	0.25 dB
10 %	0.20 dB
1 %	0.24 dB
.1 %	0.28 dB
.01 %	0.28 dB

Date: 8.MAY.2015 18:59:39



<b>Band :</b>	GSM 850	<b>Test Mode :</b>	EDGE class 8 Link (8PSK)
---------------	---------	--------------------	--------------------------

**Peak-to-Average Ratio on Channel 128 (824.2 MHz)**

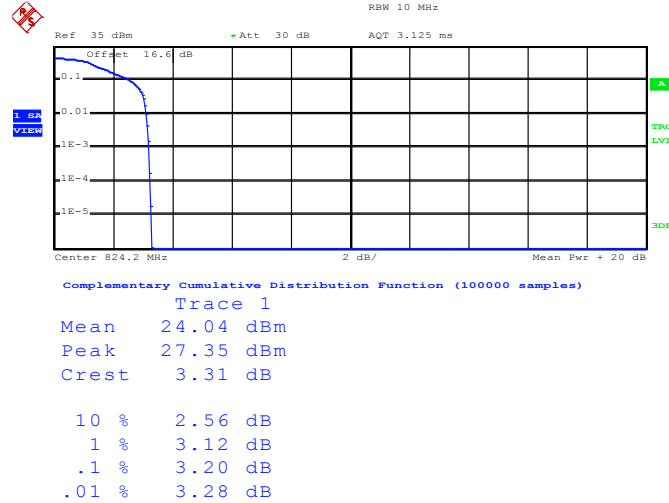

Date: 8.MAY.2015 19:14:50

**Peak-to-Average Ratio on Channel 189 (836.4 MHz)**

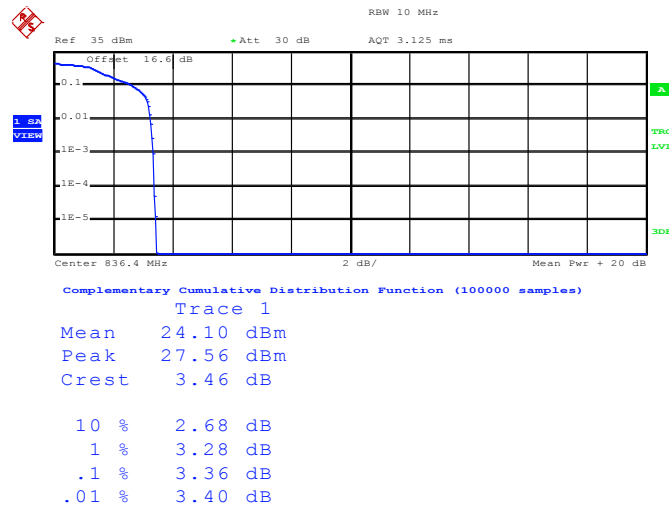

Date: 8.MAY.2015 19:15:44



Peak-to-Average Ratio on Channel 251 (848.8 MHz)

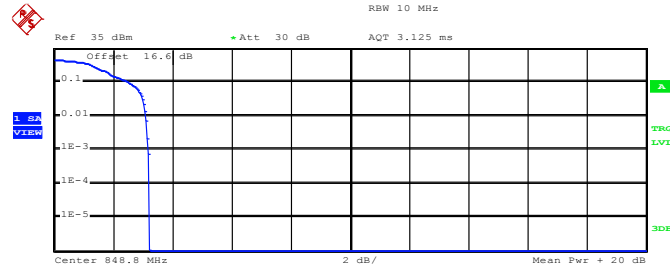

Complementary Cumulative Distribution Function (100000 samples)

Trace 1	
Mean	24.35 dBm
Peak	27.56 dBm
Crest	3.22 dB
10 %	2.56 dB
1 %	3.12 dB
.1 %	3.20 dB
.01 %	3.24 dB

Date: 8.MAY.2015 19:16:03



<b>Band :</b>	GSM 1900	<b>Test Mode :</b>	GSM Link (GMSK)
---------------	----------	--------------------	-----------------

Peak-to-Average Ratio on Channel 512 (1850.2 MHz)

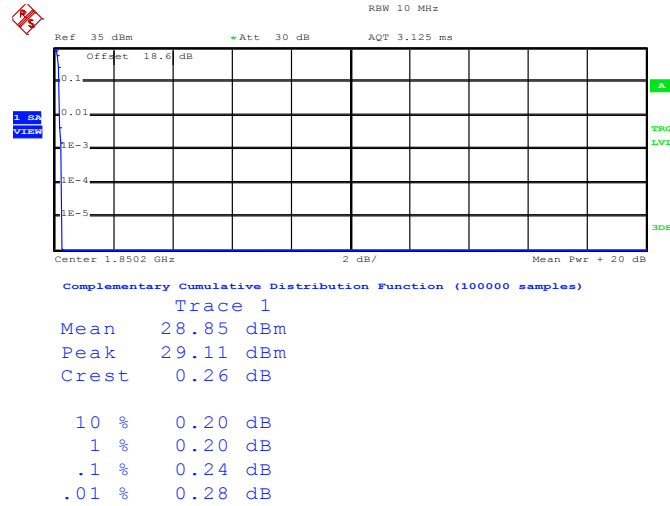

Date: 8.MAY.2015 19:50:49

Peak-to-Average Ratio on Channel 661 (1880.0 MHz)

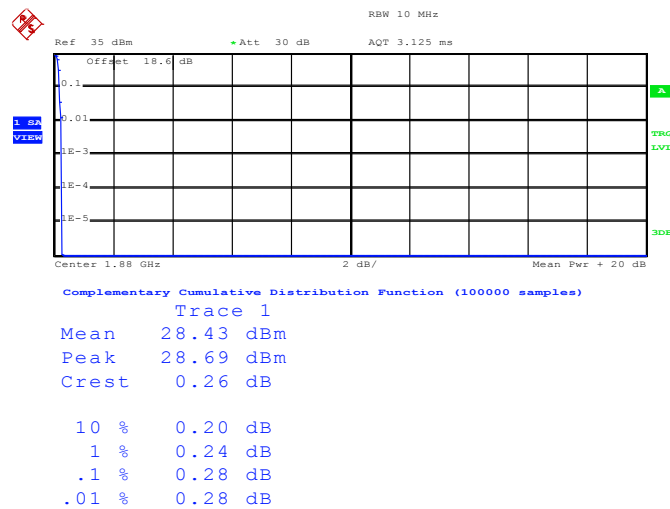

Date: 8.MAY.2015 19:51:02



Peak-to-Average Ratio on Channel 810 (1909.8 MHz)

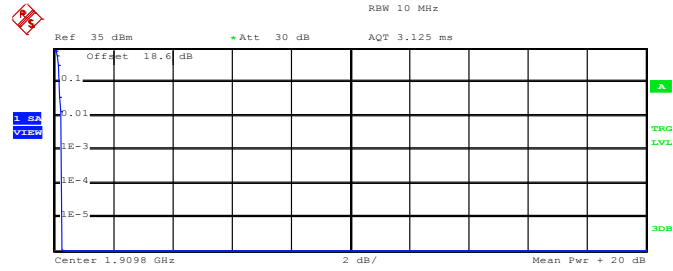

Complementary Cumulative Distribution Function (100000 samples)

Trace 1

Mean	28.07 dBm
Peak	28.34 dBm
Crest	0.26 dB
10 %	0.20 dB
1 %	0.24 dB
.1 %	0.28 dB
.01 %	0.28 dB

Date: 8.MAY.2015 19:51:13



<b>Band :</b>	GSM 1900	<b>Test Mode :</b>	EDGE class 8 Link (8PSK)
---------------	----------	--------------------	--------------------------

**Peak-to-Average Ratio on Channel 512 (1850.2 MHz)**

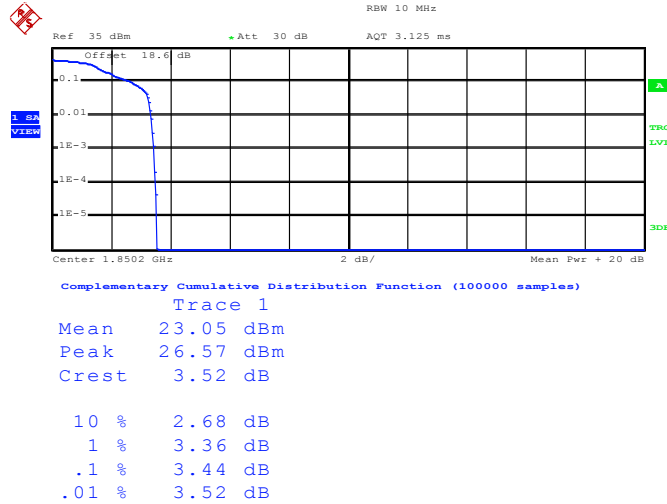

Date: 8.MAY.2015 19:39:23

**Peak-to-Average Ratio on Channel 661 (1880.0 MHz)**

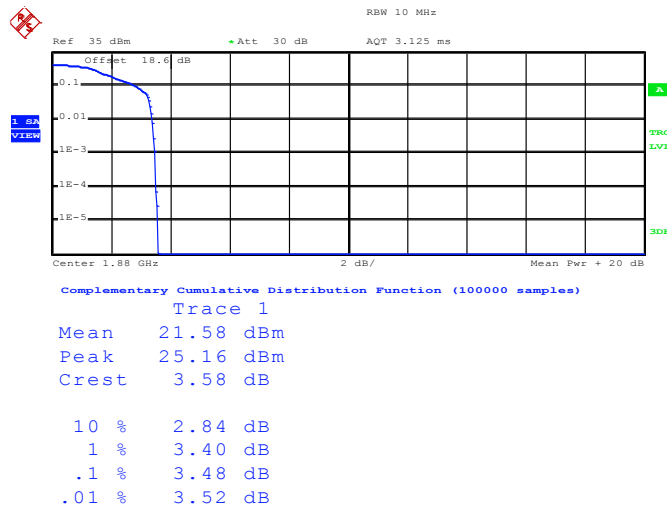

Date: 8.MAY.2015 19:39:42



Peak-to-Average Ratio on Channel 810 (1909.8 MHz)

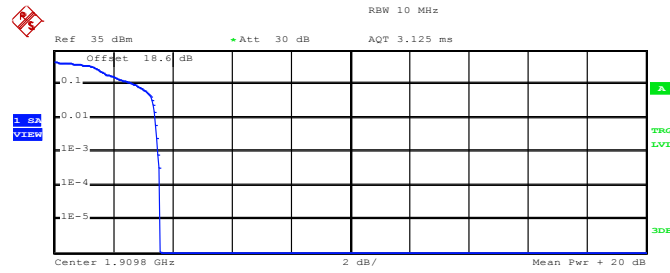

Complementary Cumulative Distribution Function (100000 samples)

Trace 1	
Mean	20.94 dBm
Peak	24.53 dBm
Crest	3.58 dB
10 %	2.76 dB
1 %	3.44 dB
.1 %	3.52 dB
.01 %	3.60 dB

Date: 8.MAY.2015 19:39:52



<b>Band :</b>	WCDMA Band V	<b>Test Mode :</b>	RMC 12.2Kbps Link (QPSK)
---------------	--------------	--------------------	--------------------------

**Peak-to-Average Ratio on Channel 4132 (826.4 MHz)**

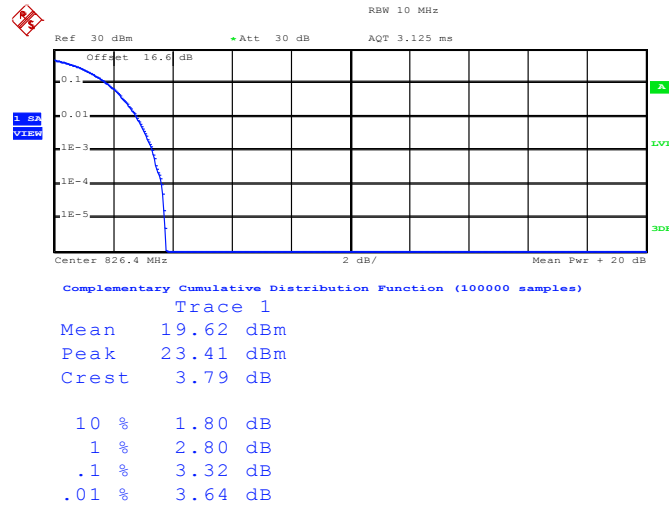

Date: 8.MAY.2015 20:03:02

**Peak-to-Average Ratio on Channel 4182 (836.4 MHz)**

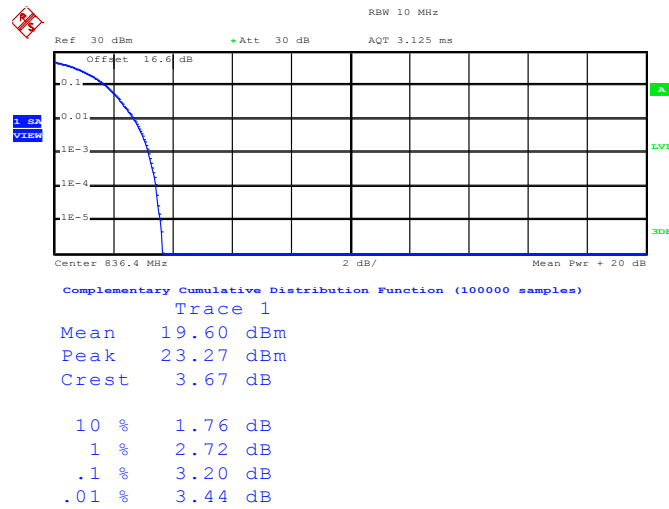

Date: 8.MAY.2015 20:03:10



Peak-to-Average Ratio on Channel 4233 (846.6 MHz)

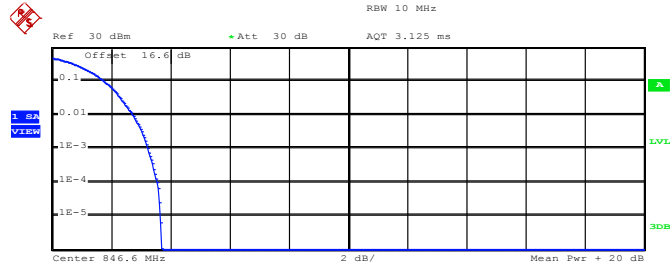

Complementary Cumulative Distribution Function (100000 samples)

Trace 1

Mean	19.34 dBm
Peak	23.06 dBm
Crest	3.72 dB
10 %	1.76 dB
1 %	2.76 dB
.1 %	3.24 dB
.01 %	3.56 dB

Date: 8.MAY.2015 20:03:18



<b>Band :</b>	WCDMA Band IV	<b>Test Mode :</b>	RMC 12.2Kbps Link (QPSK)
---------------	---------------	--------------------	--------------------------

**Peak-to-Average Ratio on Channel 1312 (1712.4 MHz)**

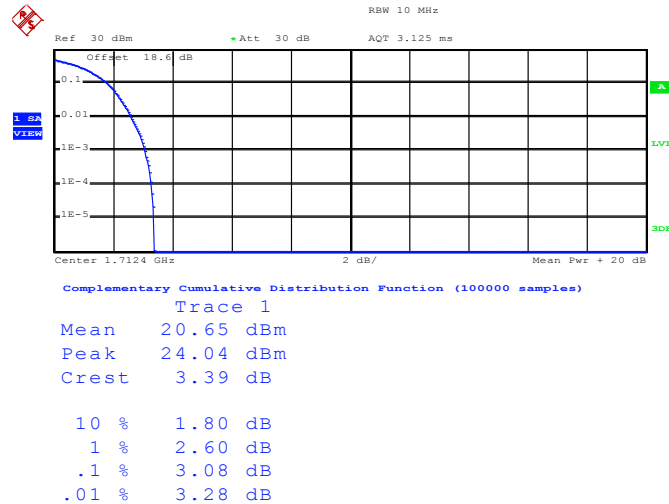

Date: 8.MAY.2015 20:25:24

**Peak-to-Average Ratio on Channel 1413 (1732.6 MHz)**

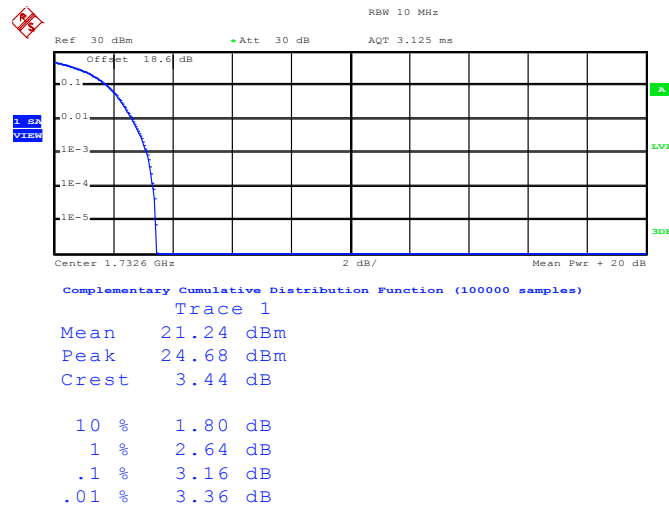

Date: 8.MAY.2015 20:25:33



Peak-to-Average Ratio on Channel 1513 (1752.6 MHz)

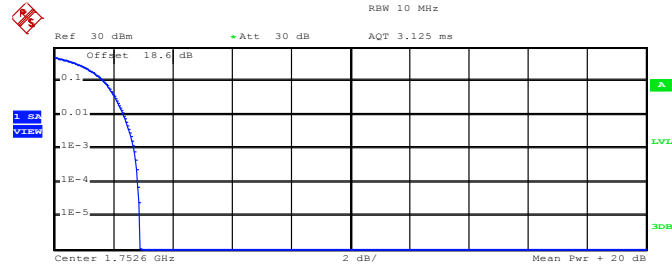

Complementary Cumulative Distribution Function (100000 samples)

Trace 1

Mean	21.20 dBm
Peak	24.11 dBm
Crest	2.91 dB
10 %	1.68 dB
1 %	2.36 dB
.1 %	2.72 dB
.01 %	2.84 dB

Date: 8.MAY.2015 20:25:41



<b>Band :</b>	WCDMA Band II	<b>Test Mode :</b>	RMC 12.2Kbps Link (QPSK)
---------------	---------------	--------------------	--------------------------

**Peak-to-Average Ratio on Channel 9262 (1852.4 MHz)**

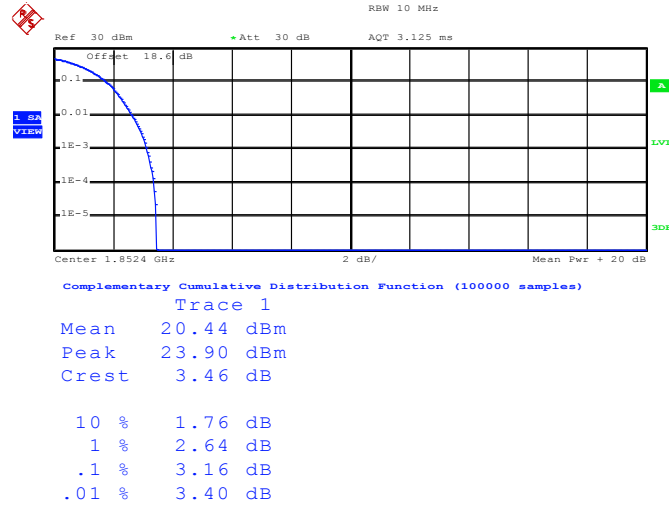

Date: 8.MAY.2015 20:12:49

**Peak-to-Average Ratio on Channel 9400 (1880.0 MHz)**

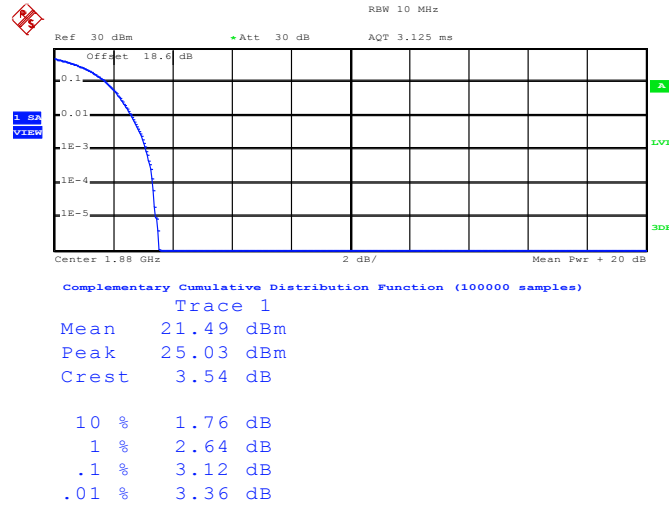

Date: 8.MAY.2015 20:12:57



Peak-to-Average Ratio on Channel 9538 (1907.6 MHz)

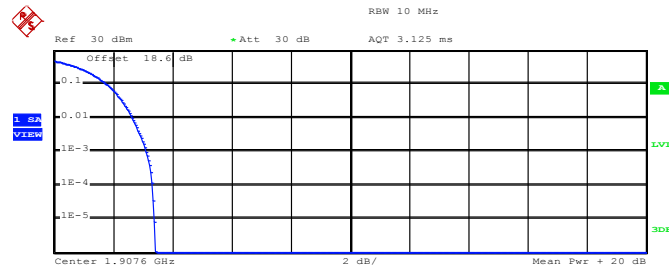

Complementary Cumulative Distribution Function (100000 samples)

Trace 1

Mean	20.78 dBm
Peak	24.18 dBm
Crest	3.41 dB
10 %	1.80 dB
1 %	2.64 dB
.1 %	3.12 dB
.01 %	3.32 dB

Date: 8.MAY.2015 20:13:05



### 3.3 Effective Radiated Power and Effective Isotropic Radiated Power Measurement

#### 3.3.1 Description of the ERP/EIRP Measurement

The substitution method, in ANSI / TIA / EIA-603-C-2004, was used for ERP/EIRP measurement, and the spectrum analyzer configuration follows KDB 971168 D01 Power Meas. License Digital Systems v02r02. The ERP of mobile transmitters must not exceed 7 Watts and the EIRP of mobile transmitters are limited to 2 Watts (PCS Band) and 1 Watts (AWS Band).

#### 3.3.2 Measuring Instruments

The measuring equipment is listed in the section 4 of this test report.

#### 3.3.3 Test Procedures

1. The testing follows FCC KDB 971168 v02r02 Section 5.2.1. (for CDMA/WCDMA), Section 5.2.2.2 (for GSM/GPRS/EDGE) and ANSI / TIA-603-C-2004 Section 2.2.17.
2. The EUT was placed on a non-conductive rotating platform 0.8 meters high in a semi-anechoic chamber. The radiated emission at the fundamental frequency was measured at 3 m with a test antenna and a spectrum analyzer with RMS detector per section 5. of KDB 971168 D01.
3. During the measurement, the system simulator parameters were set to force the EUT transmitting at maximum output power. The maximum emission was recorded from analyzer power level (LVL) from the 360 degrees rotation of the turntable and the test antenna raised and lowered over a range from 1 to 4 meters in both horizontally and vertically polarized orientations.
4. Effective Isotropic Radiated Power (EIRP) was measured by substitution method according to TIA/EIA-603-C. The EUT was replaced by the substitution antenna at same location, and then a known power from S.G. was applied into the dipole antenna through a Tx cable, and then recorded the maximum Analyzer reading through raised and lowered the test antenna. The correction factor (in dB) = S.G. - Tx Cable loss + Substitution antenna gain - Analyzer reading. Then the EUT's EIRP was calculated with the correction factor,  $EIRP = LVL + \text{Correction factor}$  and  $ERP = EIRP - 2.15$ . Take the record of the output power at substitution antenna.

	GSM/GPRS/EDGE	WCDMA/HSPA
SPAN	500kHz	10MHz
RBW	10kHz	100kHz
VBW	30kHz	300kHz
Detector	RMS	RMS
Trace	Average	Average
Average Type	Power	Power
Sweep Count	100	100

**3.3.4 Test Setup**

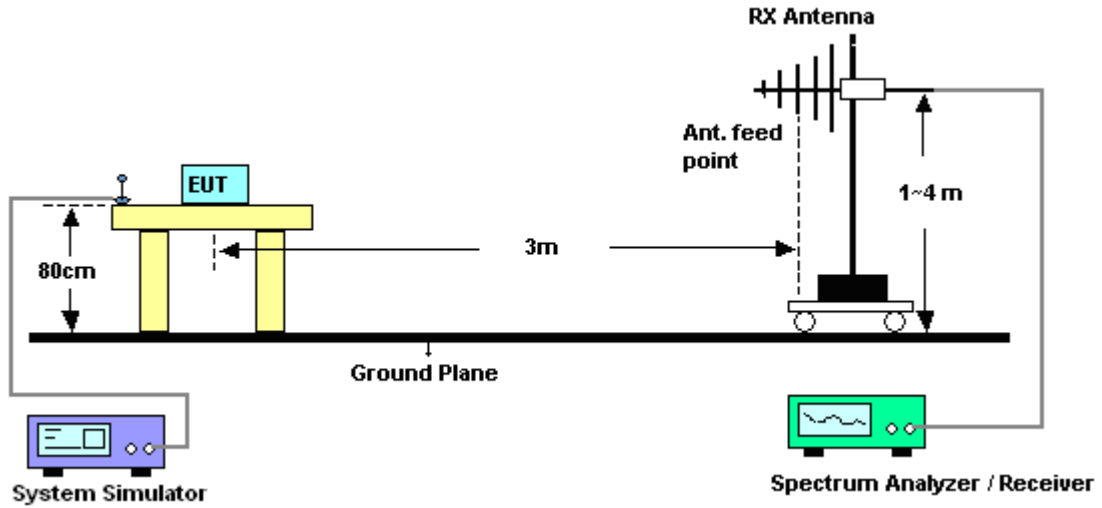



3.3.5 Test Result of ERP

GSM850 (GSM) Radiated Power ERP					
Channel	Frequency (MHz)	Horizontal		Vertical	
		ERP(dBm)	ERP(W)	ERP(dBm)	ERP(W)
Lowest	824.20	19.59	0.0910	24.36	0.2729
Middle	836.40	20.91	0.1233	26.92	0.4920
Highest	848.80	21.40	0.1380	28.77	0.7534
Limit	ERP < 7W	Result		PASS	

GSM850 (EDGE class 8) Radiated Power ERP					
Channel	Frequency (MHz)	Horizontal		Vertical	
		ERP(dBm)	ERP(W)	ERP(dBm)	ERP(W)
Lowest	824.20	13.17	0.0207	17.82	0.0605
Middle	836.40	14.29	0.0269	20.37	0.1089
Highest	848.80	14.74	0.0298	22.00	0.1585
Limit	ERP < 7W	Result		PASS	

WCDMA Band V (RMC 12.2Kbps) Radiated Power ERP					
Channel	Frequency (MHz)	Horizontal		Vertical	
		ERP(dBm)	ERP(W)	ERP(dBm)	ERP(W)
Lowest	826.40	12.18	0.0165	16.99	0.0500
Middle	836.40	12.68	0.0185	18.69	0.0740
Highest	846.60	13.44	0.0221	20.51	0.1125
Limit	ERP < 7W	Result		PASS	



3.3.6 Test Result of EIRP

GSM1900 (GSM) Radiated Power EIRP					
Channel	Frequency (MHz)	Horizontal		Vertical	
		EIRP(dBm)	EIRP(W)	EIRP(dBm)	EIRP(W)
Lowest	1850.20	31.22	1.3243	28.76	0.7516
Middle	1880.00	31.06	1.2764	28.66	0.7345
Highest	1909.80	31.02	1.2647	28.74	0.7482
Limit	EIRP < 2W	Result		PASS	

GSM1900 (EDGE class 8) Radiated Power EIRP					
Channel	Frequency (MHz)	Horizontal		Vertical	
		EIRP(dBm)	EIRP(W)	EIRP(dBm)	EIRP(W)
Lowest	1850.20	26.07	0.4046	23.71	0.2350
Middle	1880.00	26.42	0.4385	23.95	0.2483
Highest	1909.80	26.65	0.4624	24.37	0.2735
Limit	EIRP < 2W	Result		PASS	

WCDMA Band II (RMC 12.2Kbps) Radiated Power EIRP					
Channel	Frequency (MHz)	Horizontal		Vertical	
		EIRP(dBm)	EIRP(W)	EIRP(dBm)	EIRP(W)
Lowest	1852.40	23.52	0.2249	20.93	0.1239
Middle	1880.00	24.03	0.2529	21.50	0.1413
Highest	1907.60	23.15	0.2065	20.78	0.1197
Limit	EIRP < 2W	Result		PASS	

WCDMA Band IV(RMC 12.2Kbps) Radiated Power EIRP					
Channel	Frequency (MHz)	Horizontal		Vertical	
		EIRP(dBm)	EIRP(W)	EIRP(dBm)	EIRP(W)
Lowest	1712.40	23.33	0.2153	22.48	0.1770
Middle	1732.60	23.75	0.2371	22.41	0.1742
Highest	1752.60	23.52	0.2249	23.03	0.2009
Limit	EIRP < 1W	Result		PASS	

## 3.4 99% Occupied Bandwidth and 26dB Bandwidth Measurement

### 3.4.1 Description of 99% Occupied Bandwidth and 26dB Bandwidth Measurement

The 99% occupied bandwidth is the width of a frequency band such that, below the lower and above the upper frequency limits, the mean powers emitted are each equal to a specified percentage 0.5% of the total mean transmitted power.

The emission bandwidth is defined as the width of the signal between two points, located at the 2 sides of the carrier frequency, outside of which all emissions are attenuated at least 26 dB below the transmitter power.

### 3.4.2 Measuring Instruments

The measuring equipment is listed in the section 4 of this test report.

### 3.4.3 Test Procedures

1. The testing follows FCC KDB 971168 v02r02 Section 4.2.
2. The EUT was connected to the spectrum analyzer and system simulator via a power divider.
3. The RF output of the EUT was connected to the spectrum analyzer by RF cable and attenuator. The path loss was compensated to the results for each measurement.
4. The 99% occupied bandwidth were measured, set RBW= 1% of span, VBW= 3\*RBW, sample detector, trace maximum hold.
5. The 26dB bandwidth were measured, set RBW= 1% of EBW, VBW= 3\*RBW, peak detector, trace maximum hold.

### 3.4.4 Test Setup

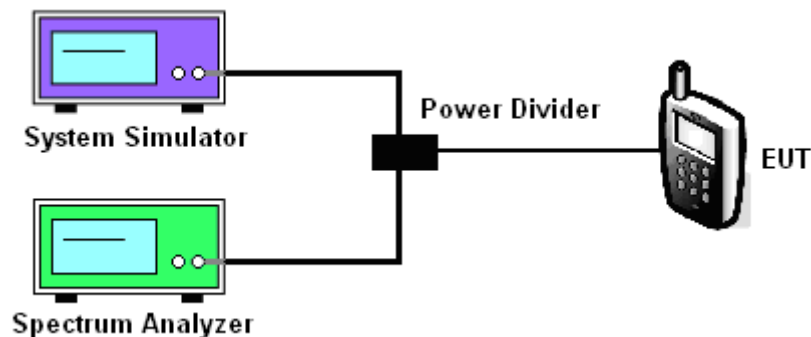



3.4.5 Test Result of Occupied Bandwidth and 26dB Bandwidth

Cellular Band						
Modes	GSM850 (GSM)			GSM850 (EDGE class 8)		
Channel	128 (Low)	189 (Mid)	251 (High)	128 (Low)	189 (Mid)	251 (High)
Frequency (MHz)	824.2	836.4	848.8	824.2	836.4	848.8
99% OBW (kHz)	244.00	246.00	243.00	231.00	240.00	241.00
26dB BW (kHz)	315.00	312.00	293.00	299.00	285.00	301.00

PCS Band						
Modes	GSM1900 (GSM)			GSM1900 (EDGE class 8)		
Channel	512 (Low)	661 (Mid)	810 (High)	512 (Low)	661 (Mid)	810 (High)
Frequency (MHz)	1850.2	1880	1909.8	1850.2	1880	1909.8
99% OBW (kHz)	247.00	246.00	247.00	245.00	239.00	242.00
26dB BW (kHz)	308.00	292.00	316.00	300.00	309.00	305.00

Cellular Band			
Modes	WCDMA Band V (RMC 12.2Kbps)		
Channel	4132 (Low)	4182 (Mid)	4233 (High)
Frequency (MHz)	826.4	836.4	846.6
99% OBW (MHz)	4.15	4.15	4.15
26dB BW (MHz)	4.66	4.67	4.66

AWS Band			
Modes	WCDMA Band IV (RMC 12.2Kbps)		
Channel	1312(Low)	1413 (Mid)	1513 (High)
Frequency (MHz)	1712.4	1732.6	1752.6
99% OBW (MHz)	4.17	4.18	4.18
26dB BW (MHz)	4.66	4.67	4.69



<b>PCS Band</b>			
<b>Modes</b>	<b>WCDMA Band II (RMC 12.2Kbps)</b>		
<b>Channel</b>	<b>9262 (Low)</b>	<b>9400 (Mid)</b>	<b>9538 (High)</b>
<b>Frequency (MHz)</b>	<b>1852.4</b>	<b>1880</b>	<b>1907.6</b>
<b>99% OBW (MHz)</b>	4.17	4.18	4.17
<b>26dB BW (MHz)</b>	4.69	4.66	4.67



### 3.4.6 Test Result (Plots) of Occupied Bandwidth and 26dB Bandwidth

Band :	GSM 850	Test Mode :	GSM Link (GMSK)
--------	---------	-------------	-----------------

#### 99% Occupied Bandwidth Plot on Channel 128 (824.2 MHz)

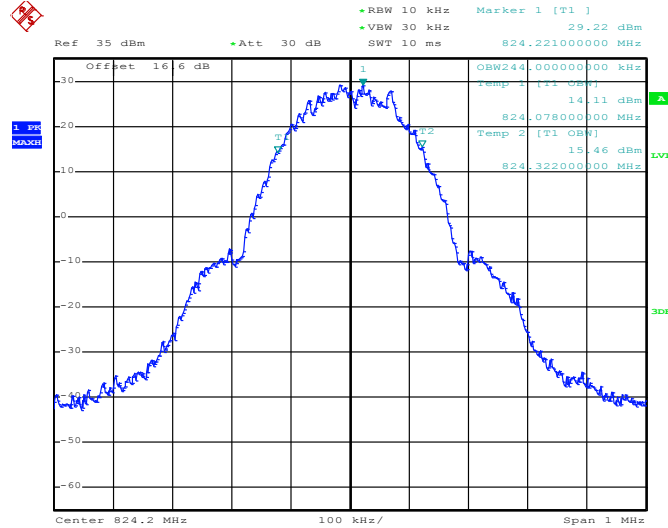

Date: 8.MAY.2015 18:52:57

#### 26dB Bandwidth Plot on Channel 128 (824.2 MHz)

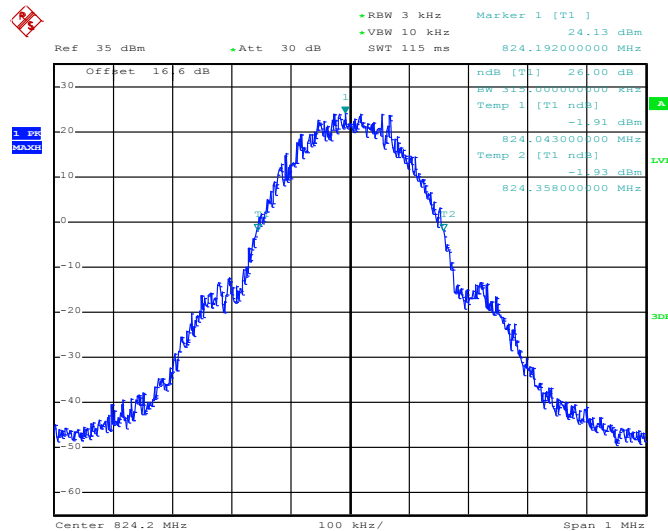

Date: 8.MAY.2015 18:49:48



99% Occupied Bandwidth Plot on Channel 189 (836.4 MHz)

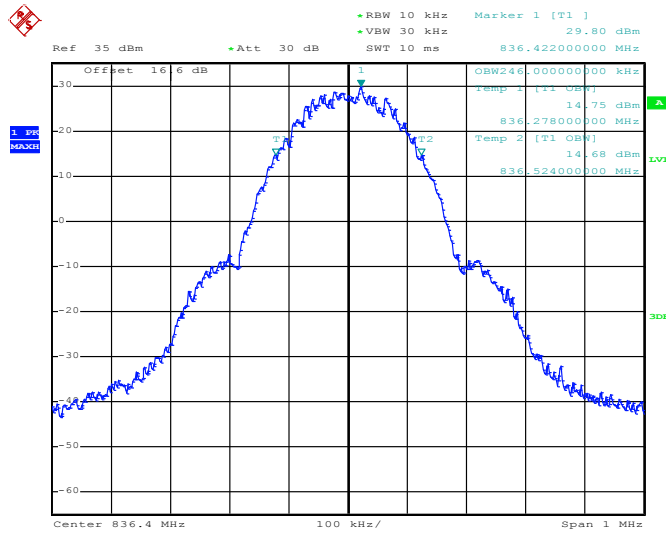

Date: 8.MAY.2015 18:53:25

26dB Bandwidth Plot on Channel 189 (836.4 MHz)

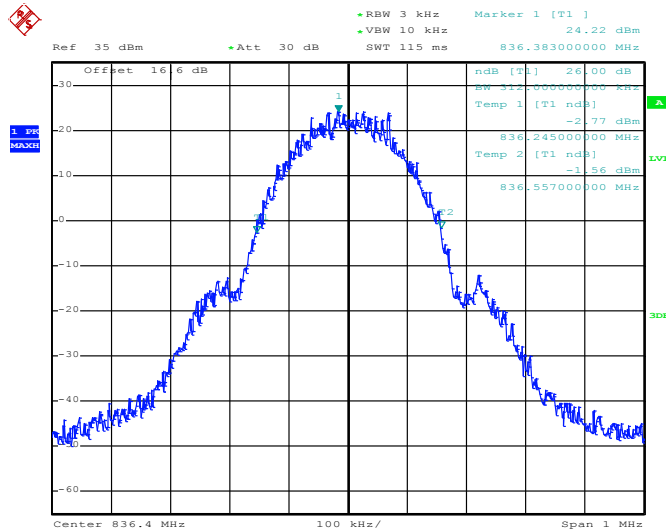

Date: 8.MAY.2015 18:50:16



99% Occupied Bandwidth Plot on Channel 251 (848.8 MHz)

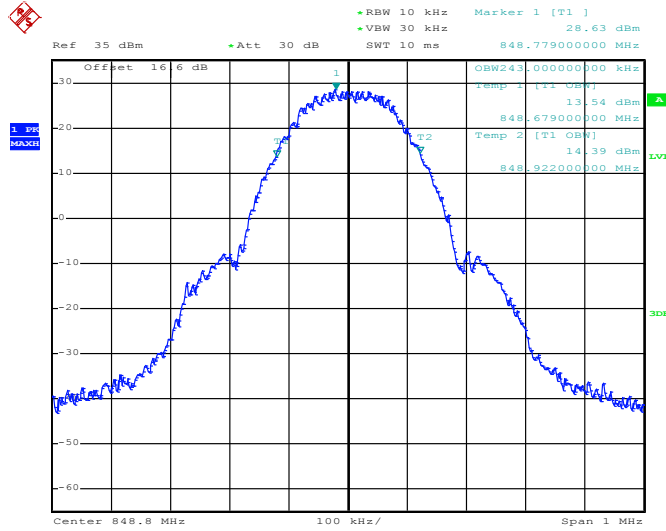

Date: 8.MAY.2015 18:53:53

26dB Bandwidth Plot on Channel 251 (848.8 MHz)

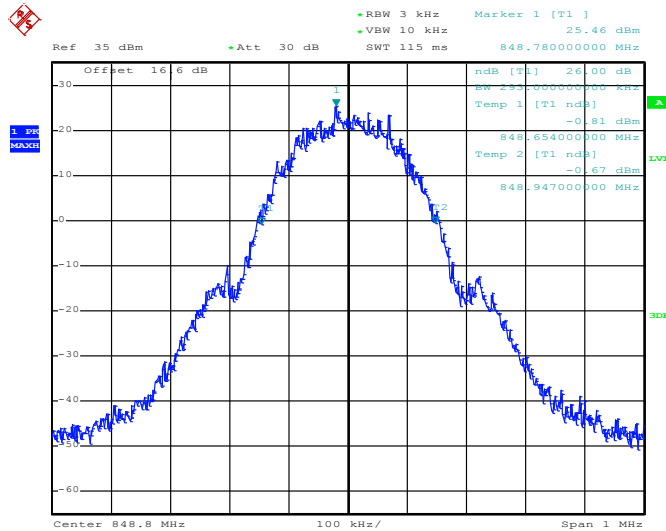

Date: 8.MAY.2015 18:50:44



<b>Band :</b>	GSM 850	<b>Test Mode :</b>	EDGE class 8 Link (8PSK)
---------------	---------	--------------------	--------------------------

99% Occupied Bandwidth Plot on Channel 128 (824.2 MHz)

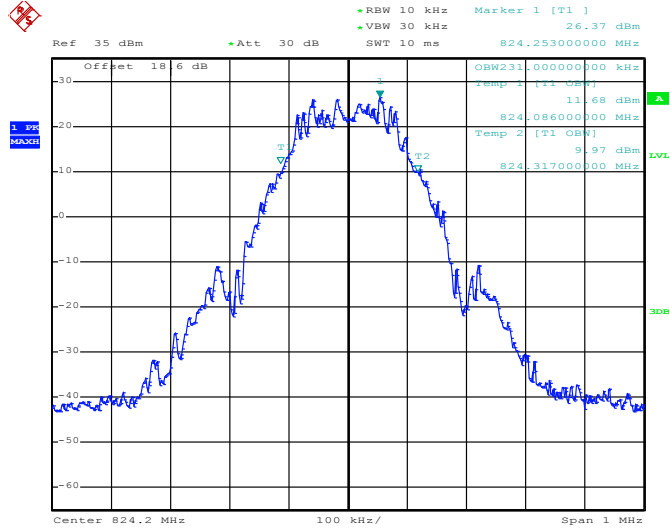

Date: 9.MAY.2015 14:55:43

26dB Bandwidth Plot on Channel 128 (824.2 MHz)

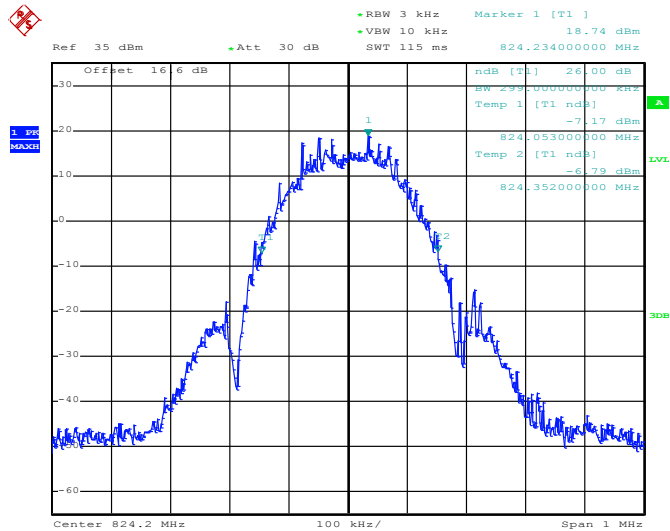

Date: 8.MAY.2015 19:03:07



99% Occupied Bandwidth Plot on Channel 189 (836.4 MHz)

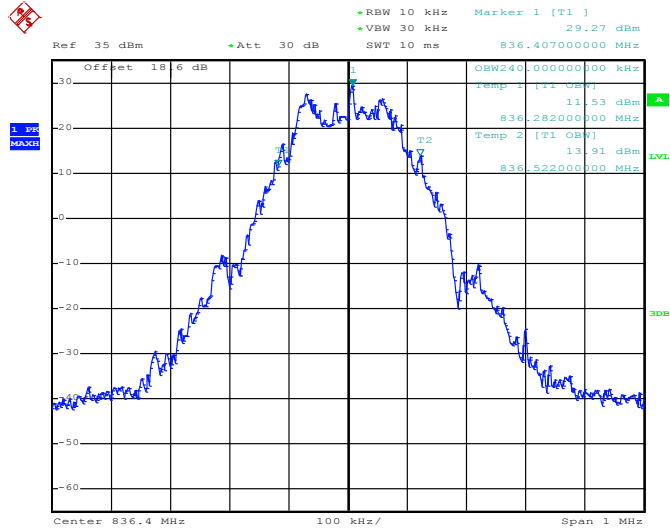

Date: 9.MAY.2015 14:56:11

26dB Bandwidth Plot on Channel 189 (836.4 MHz)

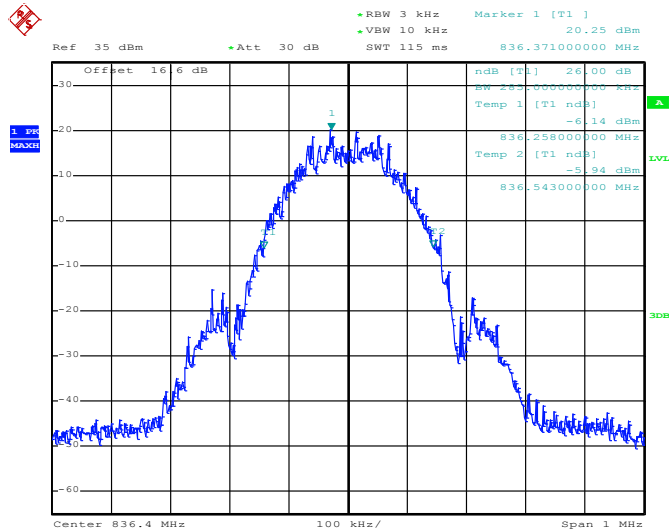

Date: 8.MAY.2015 19:03:36



99% Occupied Bandwidth Plot on Channel 251 (848.8 MHz)

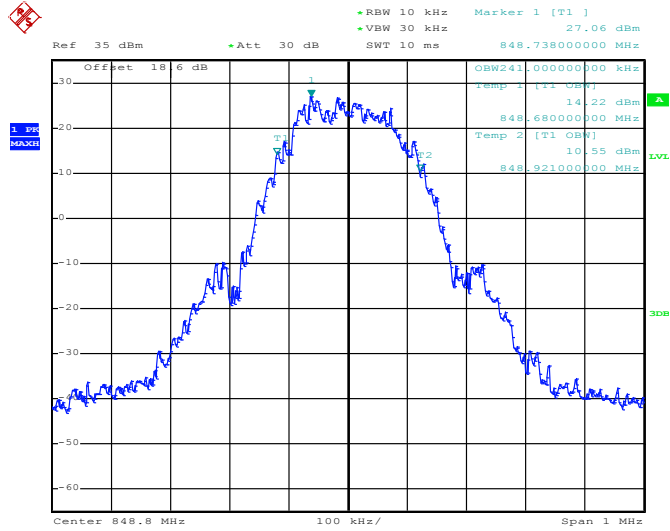

Date: 9.MAY.2015 14:56:40

26dB Bandwidth Plot on Channel 251 (848.8 MHz)

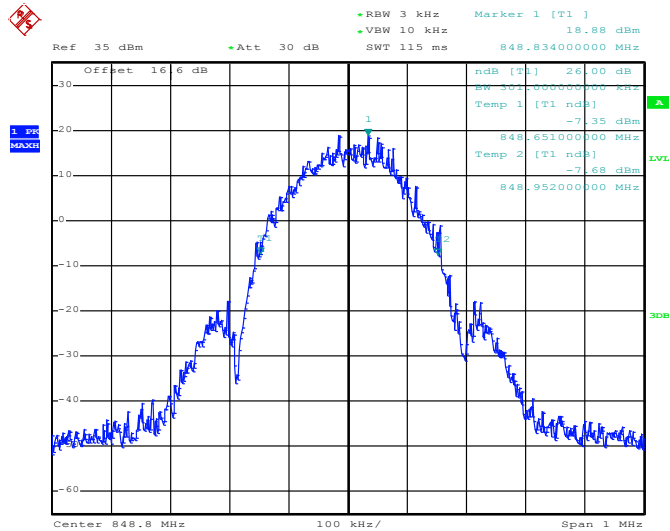

Date: 8.MAY.2015 19:04:04



Band :	GSM 1900	Test Mode :	GSM Link (GMSK)
--------	----------	-------------	-----------------

99% Occupied Bandwidth Plot on Channel 512 (1850.2 MHz)

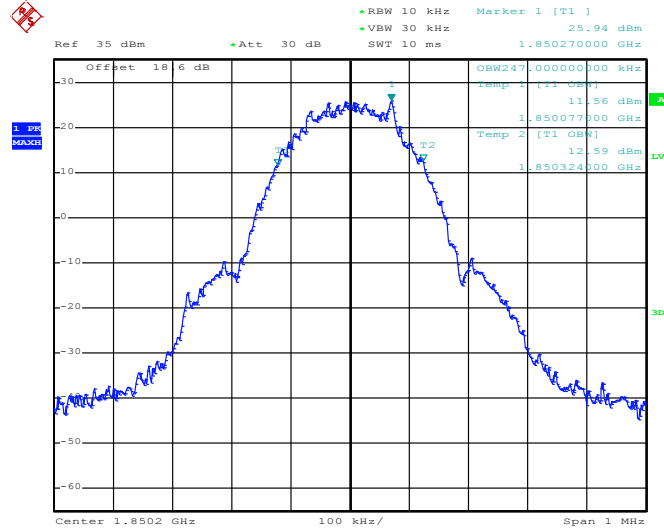

Date: 8.MAY.2015 19:44:35

26dB Bandwidth Plot on Channel 512 (1850.2 MHz)

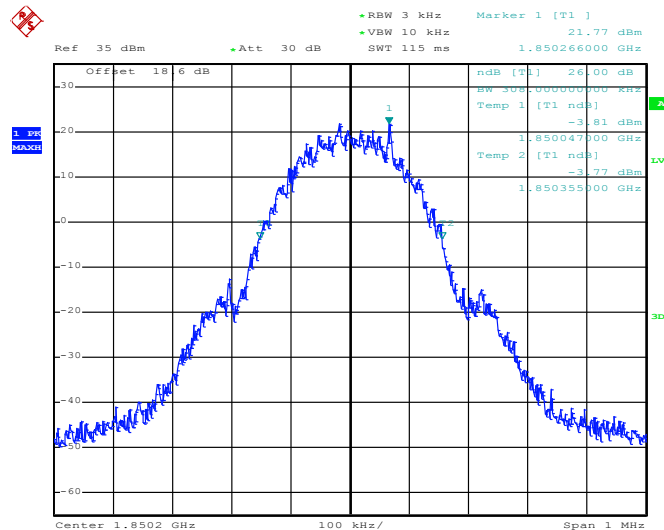

Date: 8.MAY.2015 19:41:07



99% Occupied Bandwidth Plot on Channel 661 (1880.0 MHz)

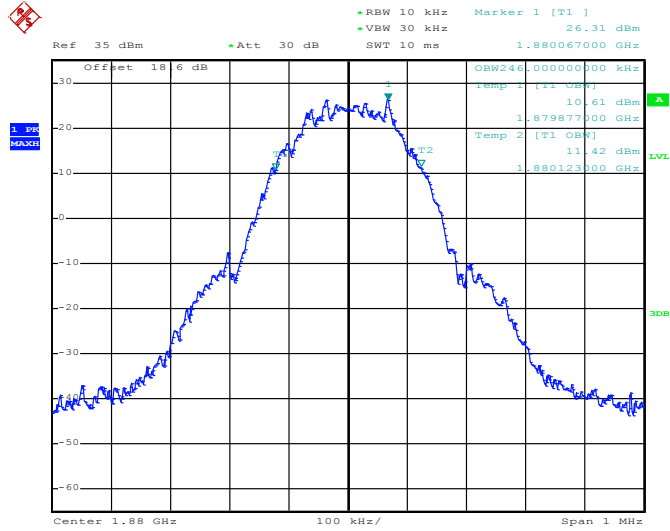

Date: 8.MAY.2015 19:45:03

26dB Bandwidth Plot on Channel 661 (1880.0 MHz)

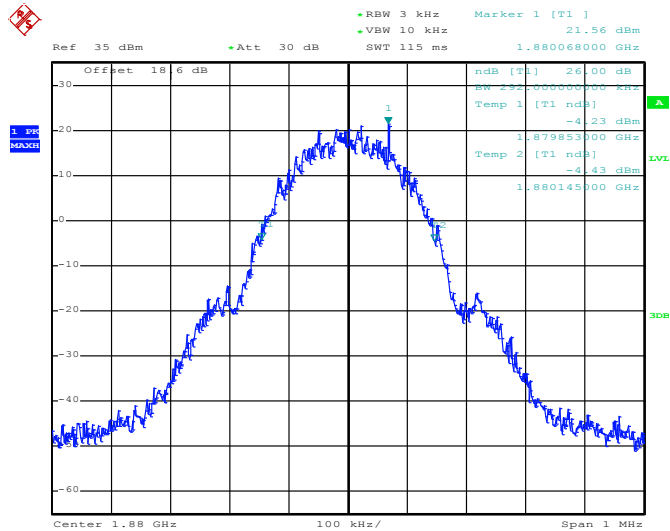

Date: 8.MAY.2015 19:41:35



99% Occupied Bandwidth Plot on Channel 810 (1909.8 MHz)

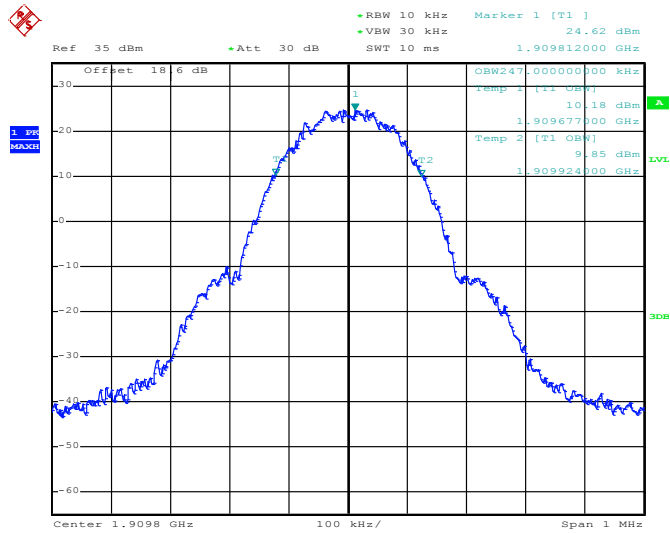

Date: 8.MAY.2015 19:45:31

26dB Bandwidth Plot on Channel 810 (1909.8 MHz)

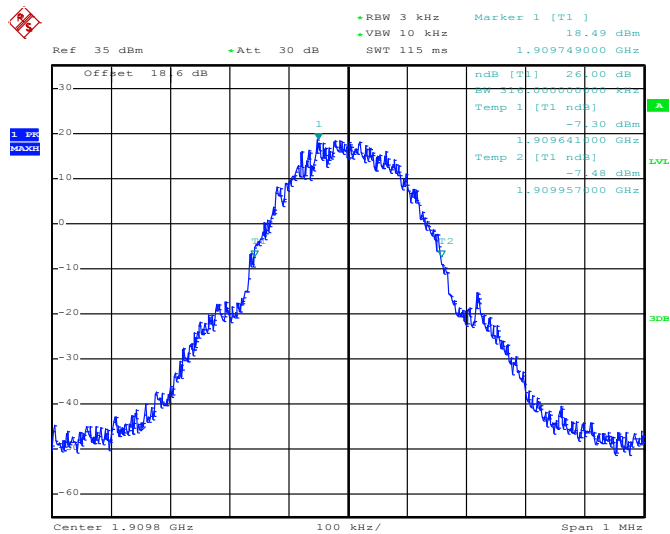

Date: 8.MAY.2015 19:42:04



<b>Band :</b>	GSM 1900	<b>Test Mode :</b>	EDGE class 8 Link (8PSK)
---------------	----------	--------------------	--------------------------

99% Occupied Bandwidth Plot on Channel 512 (1850.2 MHz)

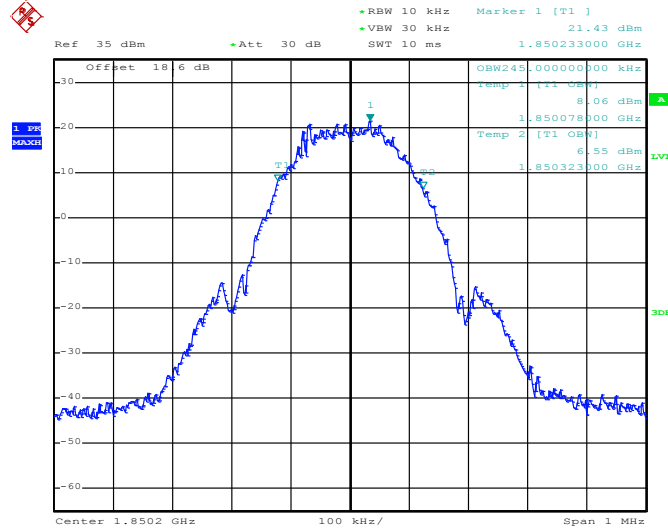

Date: 8.MAY.2015 19:27:21

26dB Bandwidth Plot on Channel 512 (1850.2 MHz)

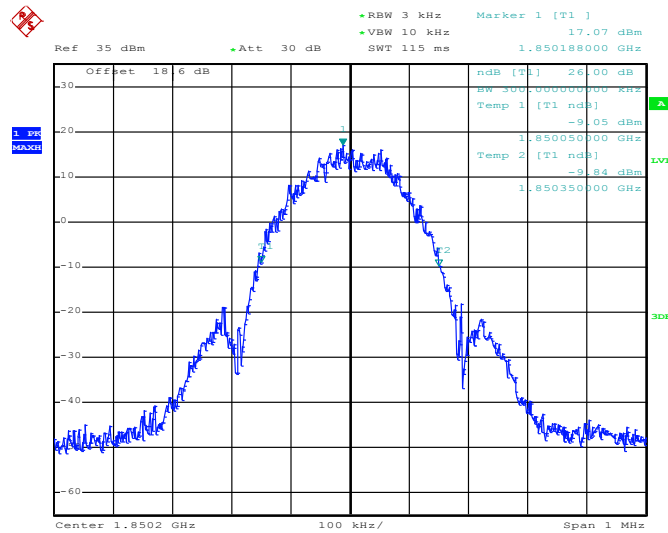

Date: 8.MAY.2015 19:23:35



99% Occupied Bandwidth Plot on Channel 661 (1880.0 MHz)

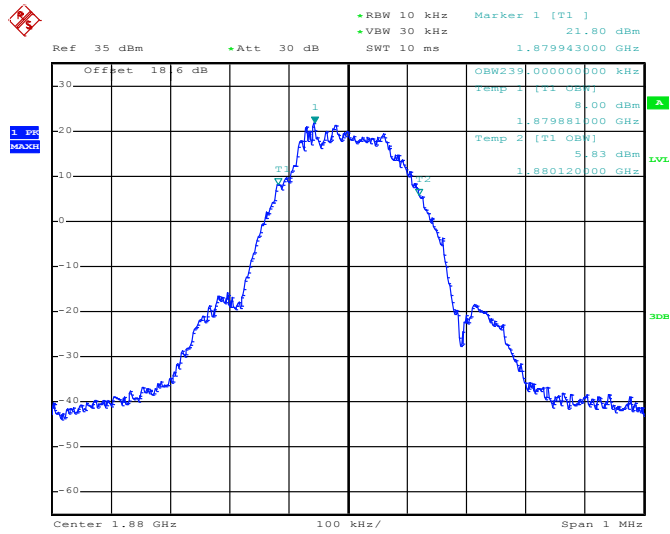

Date: 8.MAY.2015 19:32:05

26dB Bandwidth Plot on Channel 661 (1880.0 MHz)

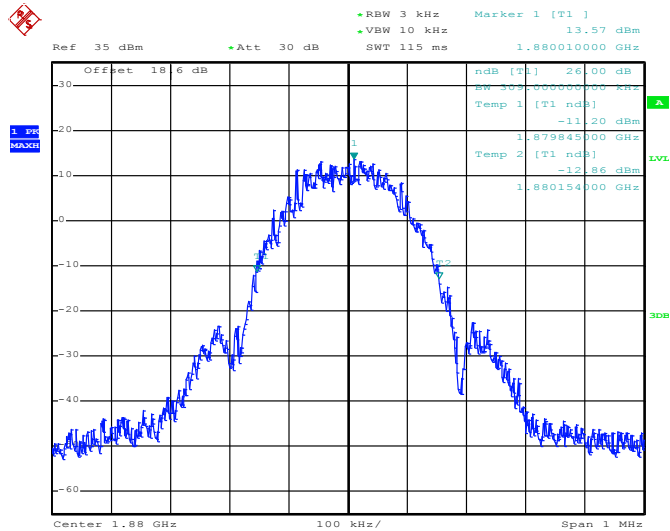

Date: 8.MAY.2015 19:24:03



99% Occupied Bandwidth Plot on Channel 810 (1909.8 MHz)

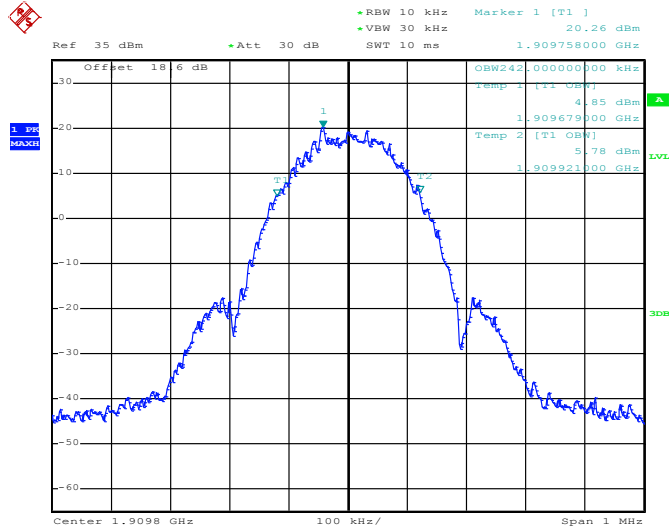

Date: 8.MAY.2015 19:28:21

26dB Bandwidth Plot on Channel 810 (1909.8 MHz)

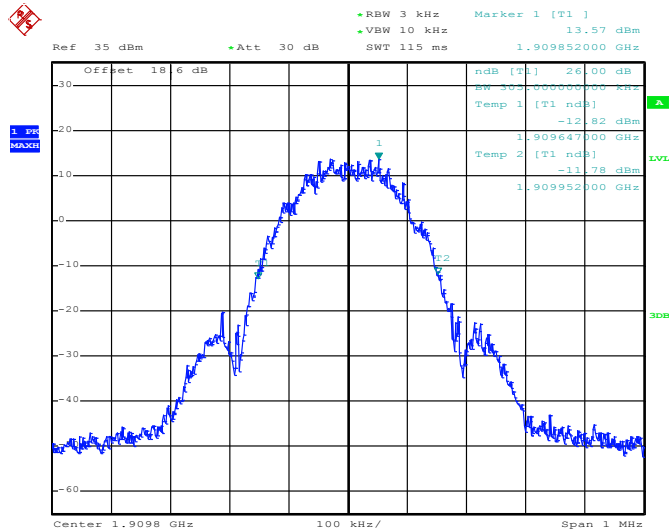

Date: 8.MAY.2015 19:24:32



<b>Band :</b>	WCDMA Band V	<b>Test Mode :</b>	RMC 12.2Kbps Link (QPSK)
---------------	--------------	--------------------	--------------------------

99% Occupied Bandwidth Plot on Channel 4132 (826.4 MHz)

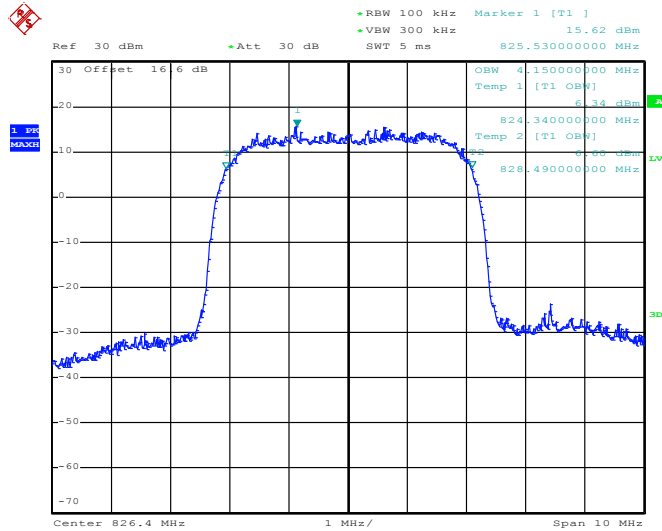

Date: 8.MAY.2015 19:56:34

26dB Bandwidth Plot on Channel 4132 (826.4 MHz)

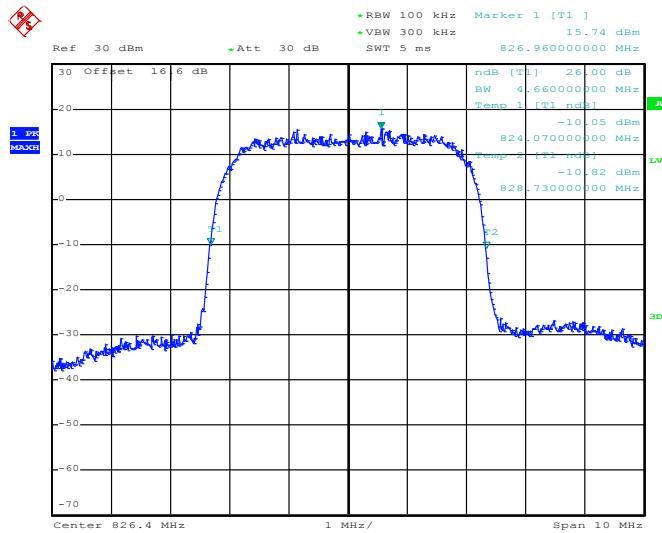

Date: 8.MAY.2015 19:54:51



99% Occupied Bandwidth Plot on Channel 4182 (836.4 MHz)

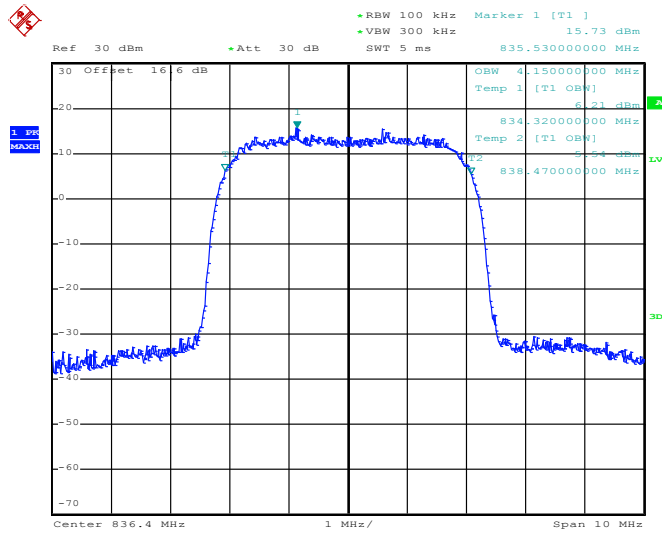

Date: 8.MAY.2015 19:57:02

26dB Bandwidth Plot on Channel 4182 (836.4 MHz)

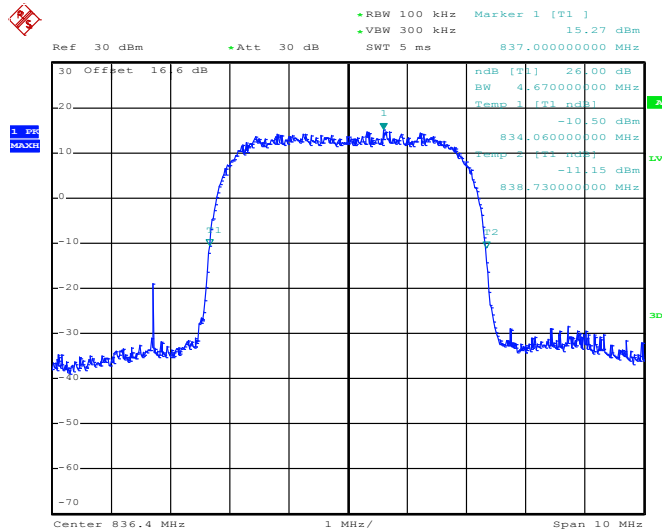

Date: 8.MAY.2015 19:55:18



99% Occupied Bandwidth Plot on Channel 4233 (846.6 MHz)

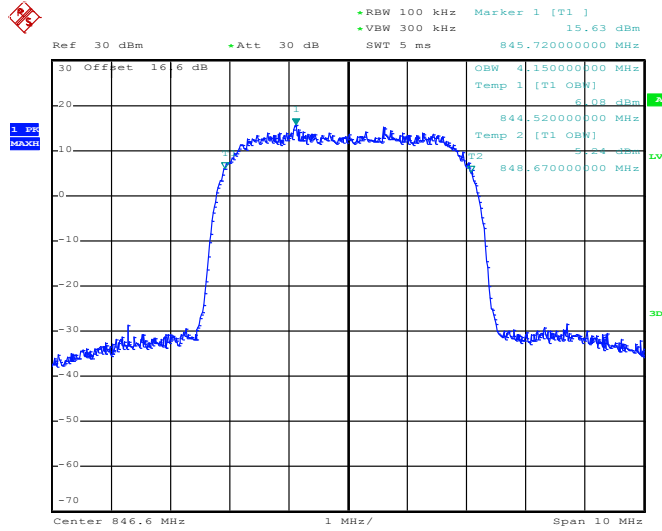

Date: 8.MAY.2015 19:57:30

26dB Bandwidth Plot on Channel 4233 (846.6 MHz)

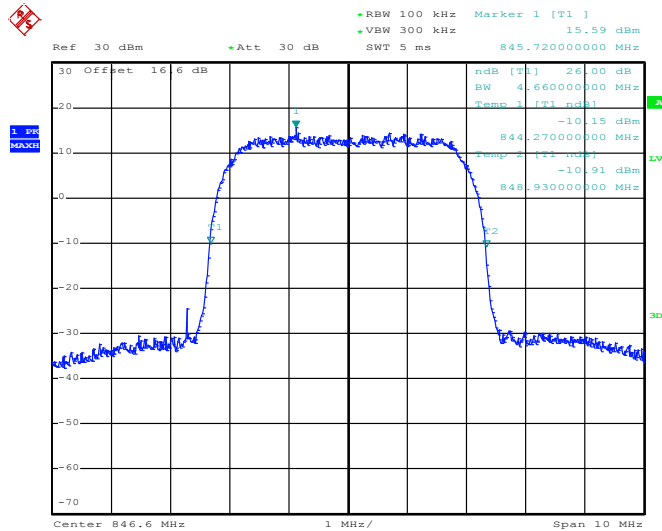

Date: 8.MAY.2015 19:55:46



<b>Band :</b>	WCDMA Band IV	<b>Test Mode :</b>	RMC 12.2Kbps Link (QPSK)
---------------	---------------	--------------------	--------------------------

99% Occupied Bandwidth Plot on Channel 1312 (1712.4 MHz)

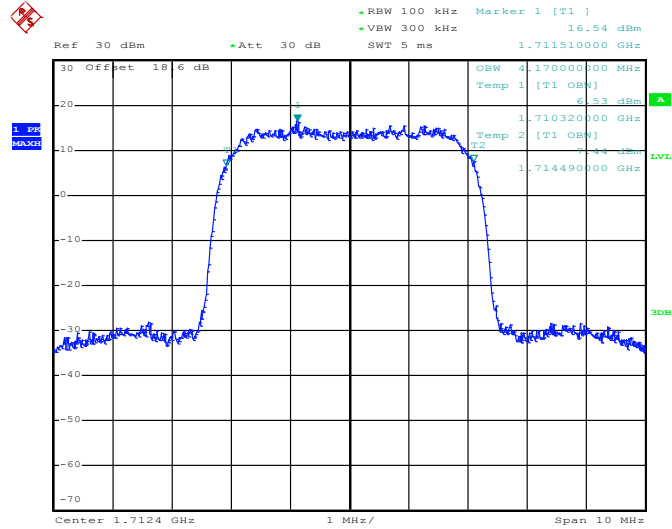

Date: 8.MAY.2015 20:18:08

26dB Bandwidth Plot on Channel 1312 (1712.4 MHz)

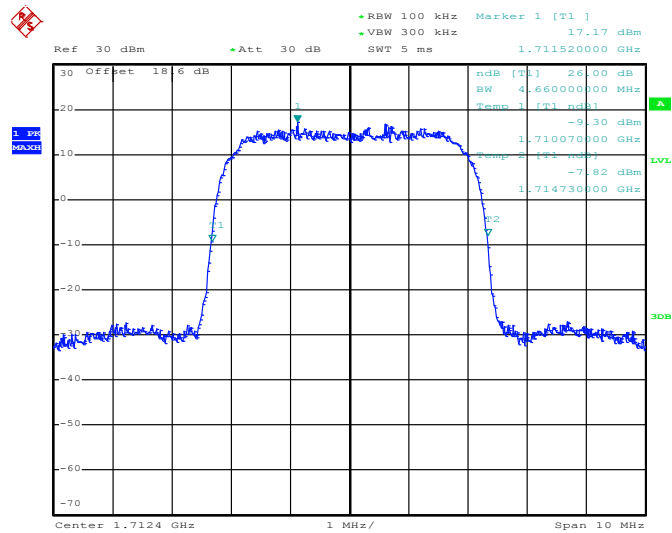

Date: 8.MAY.2015 20:14:39



99% Occupied Bandwidth Plot on Channel 1413 (1732.6 MHz)

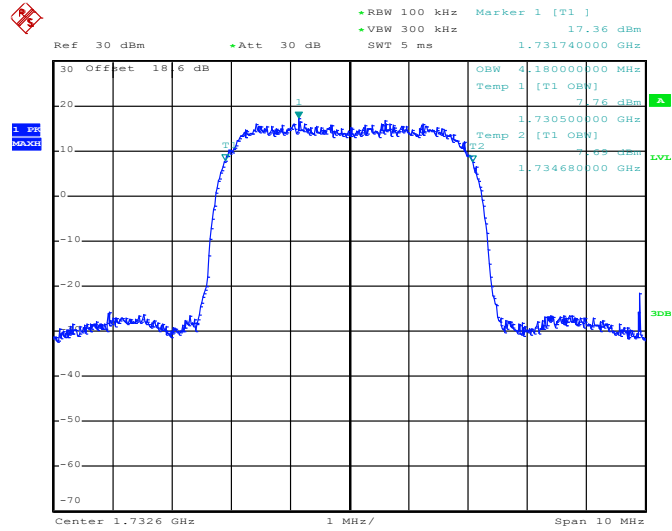

Date: 8.MAY.2015 20:18:36

26dB Bandwidth Plot on Channel 1413 (1732.6 MHz)

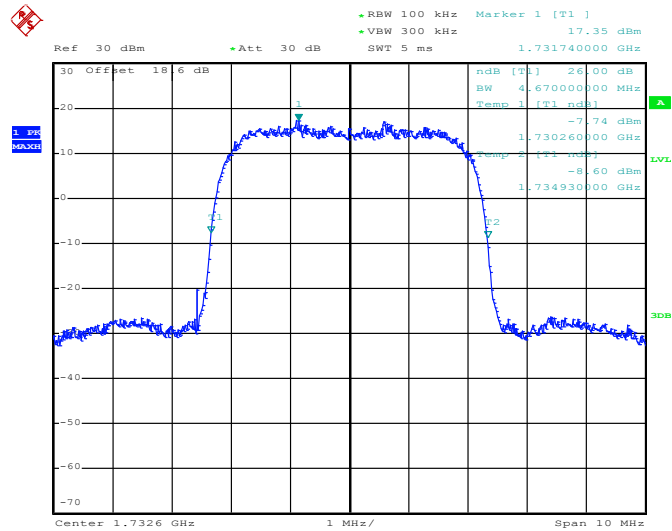

Date: 8.MAY.2015 20:15:07



99% Occupied Bandwidth Plot on Channel 1513 (1752.6 MHz)

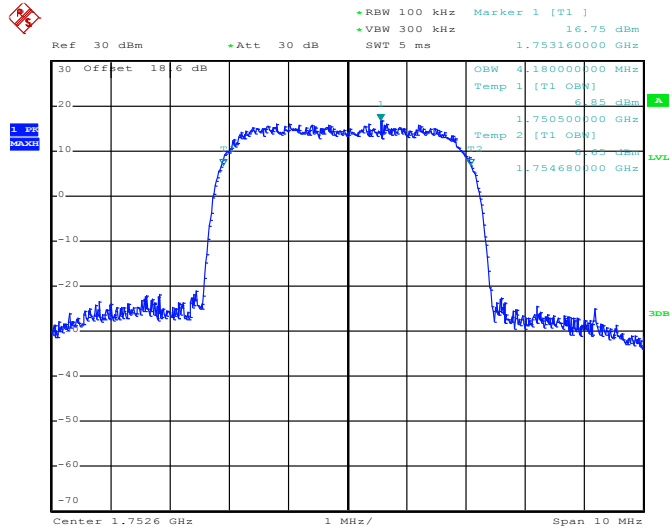

Date: 8.MAY.2015 20:19:04

26dB Bandwidth Plot on Channel 1513 (1752.6 MHz)

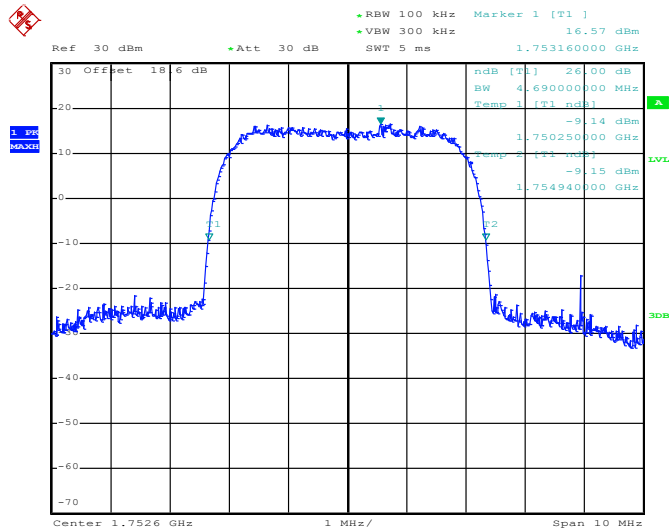

Date: 8.MAY.2015 20:15:35



<b>Band :</b>	WCDMA Band II	<b>Test Mode :</b>	RMC 12.2Kbps Link (QPSK)
---------------	---------------	--------------------	--------------------------

99% Occupied Bandwidth Plot on Channel 9262 (1852.4 MHz)

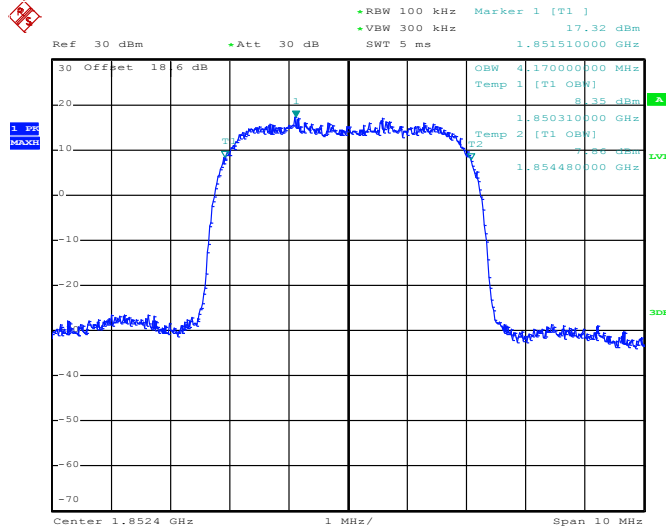

Date: 8.MAY.2015 20:07:24

26dB Bandwidth Plot on Channel 9262 (1852.4 MHz)

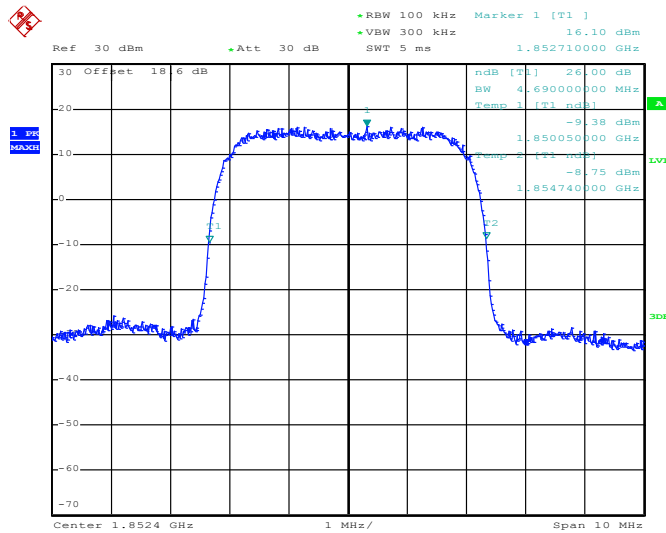

Date: 8.MAY.2015 20:05:41



99% Occupied Bandwidth Plot on Channel 9400 (1880.0 MHz)

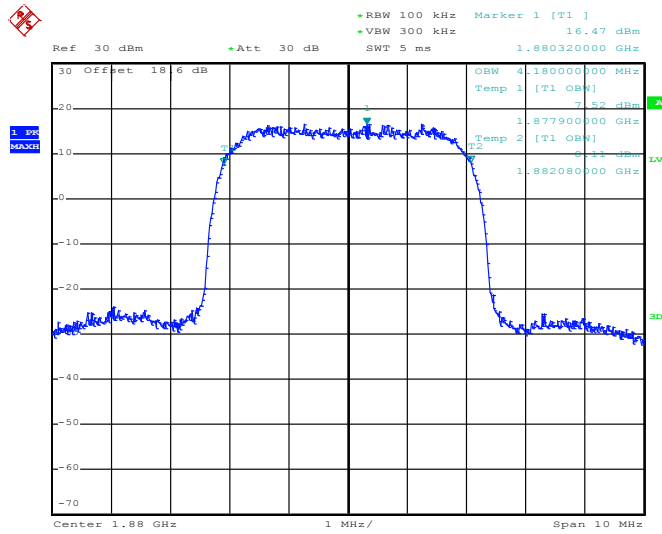

Date: 8.MAY.2015 20:07:52

26dB Bandwidth Plot on Channel 9400 (1880.0 MHz)

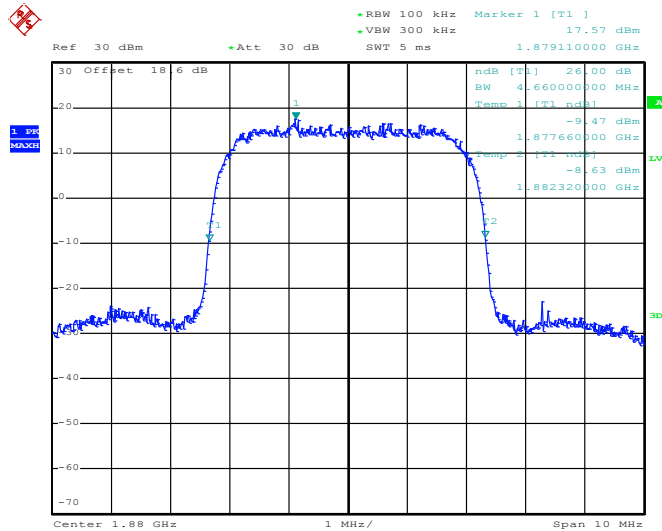

Date: 8.MAY.2015 20:06:09



99% Occupied Bandwidth Plot on Channel 9538 (1907.6 MHz)

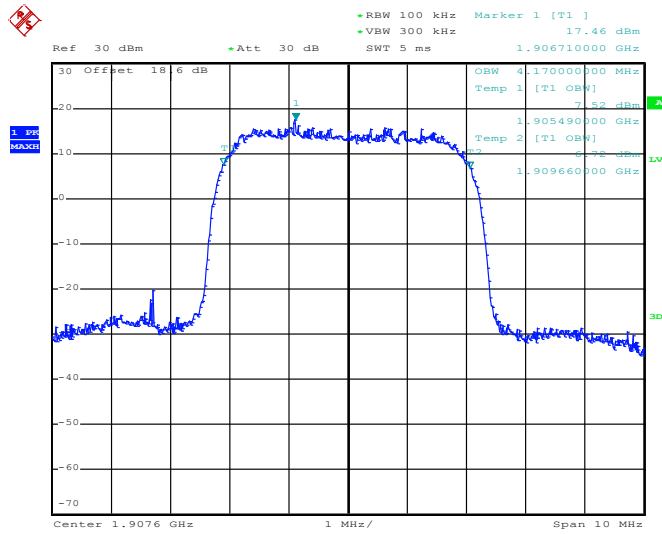

Date: 8.MAY.2015 20:08:21

26dB Bandwidth Plot on Channel 9538 (1907.6 MHz)

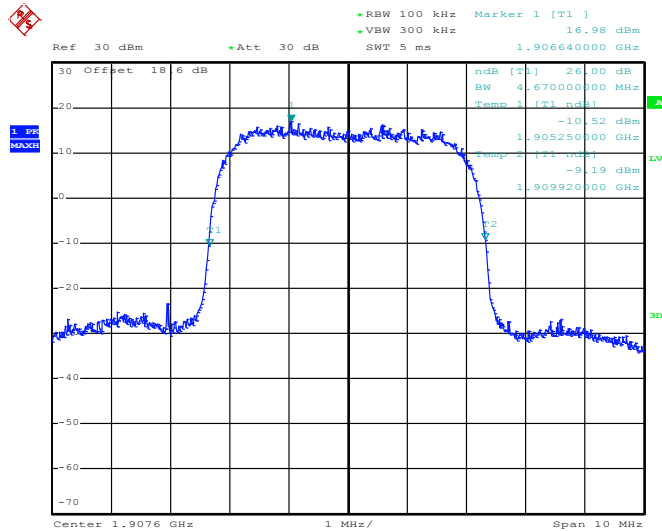

Date: 8.MAY.2015 20:06:37

## 3.5 Band Edge Measurement

### 3.5.1 Description of Band Edge Measurement

The power of any emission outside of the authorized operating frequency ranges must be lower than the transmitter power (P) by a factor of at least  $43 + 10 \log (P)$  dB.

### 3.5.2 Measuring Instruments

The measuring equipment is listed in the section 4 of this test report.

### 3.5.3 Test Procedures

1. The testing follows FCC KDB 971168 v02r02 Section 6.0.
2. The EUT was connected to the spectrum analyzer and system simulator via a power divider.
3. The RF output of EUT was connected to the spectrum analyzer by an RF cable and attenuator. The path loss was compensated to the results for each measurement.
4. The band edges of low and high channels for the highest RF powers were measured.
5. The RF fundamental frequency should be excluded against the limit line in the operating frequency band.
6. The limit line is derived from  $43 + 10\log(P)$  dB below the transmitter power P(Watts)  
 $= P(W) - [43 + 10\log(P)] \text{ (dB)}$   
 $= [30 + 10\log(P)] \text{ (dBm)} - [43 + 10\log(P)] \text{ (dB)}$   
 $= -13\text{dBm}.$

### 3.5.4 Test Setup

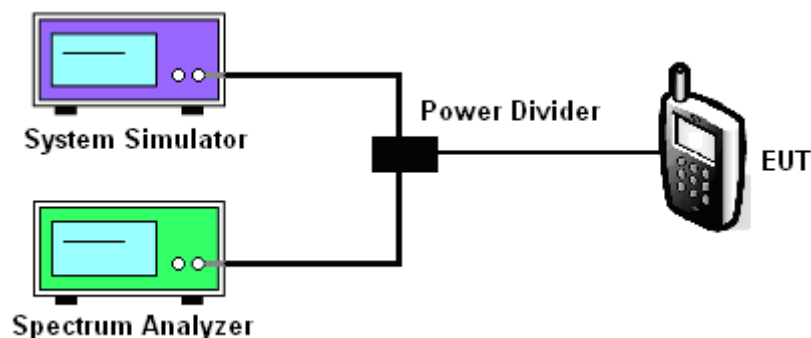



### 3.5.5 Test Result (Plots) of Conducted Band Edge

Band :	GSM850	Test Mode :	GSM Link (GMSK)
--------	--------	-------------	-----------------

#### Lower Band Edge Plot on Channel 128 (824.2 MHz)

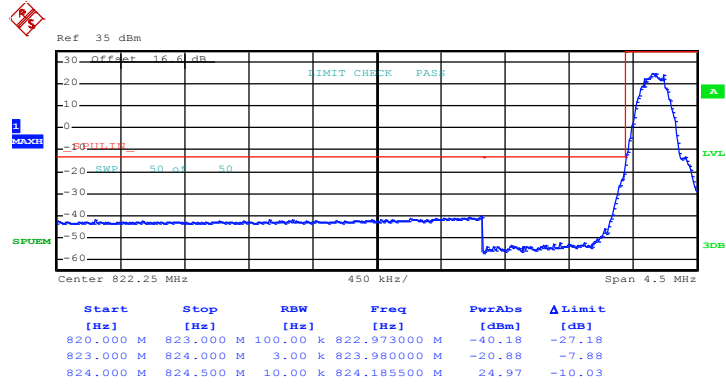

Date: 8.MAY.2015 18:55:48

#### Higher Band Edge Plot on Channel 251 (848.8 MHz)

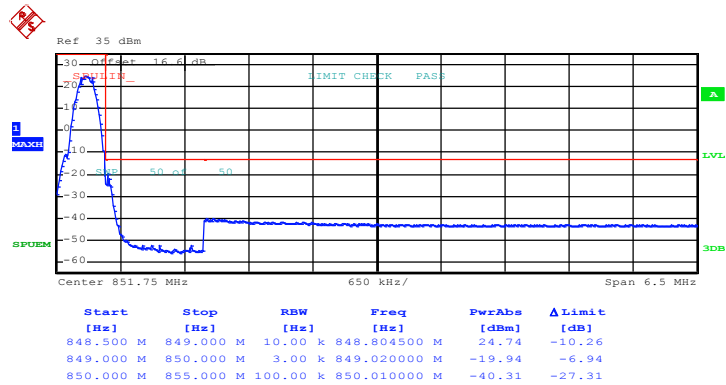

Date: 8.MAY.2015 18:57:10



Band :	GSM850	Test Mode :	EDGE class 8 Link (8PSK)
--------	--------	-------------	--------------------------

Lower Band Edge Plot on Channel 128 (824.2 MHz)

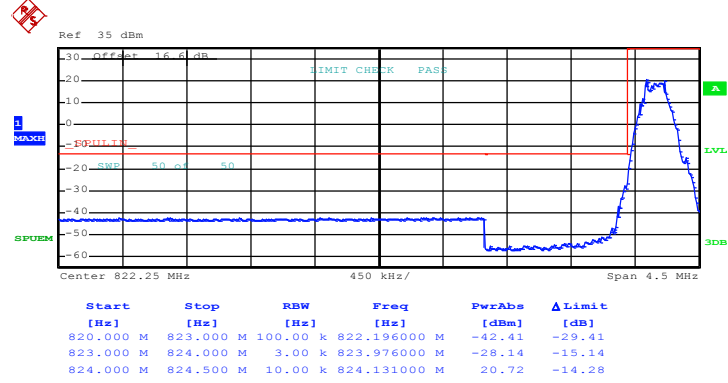

Date: 8.MAY.2015 19:10:17

Higher Band Edge Plot on Channel 251 (848.8 MHz)

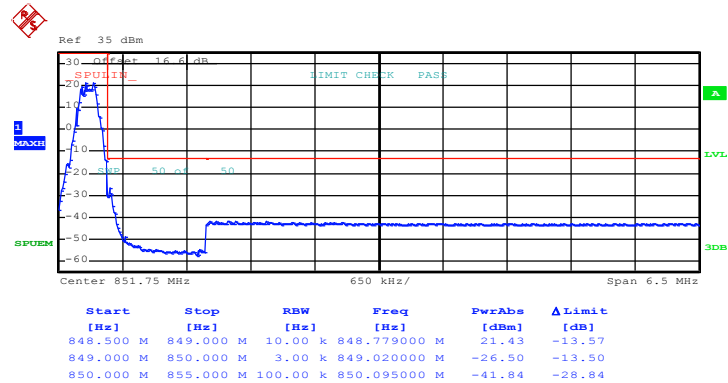

Date: 8.MAY.2015 19:11:40



Band :	GSM1900	Test Mode :	GSM Link (GMSK)
--------	---------	-------------	-----------------

Lower Band Edge Plot on Channel 512 (1850.2 MHz)

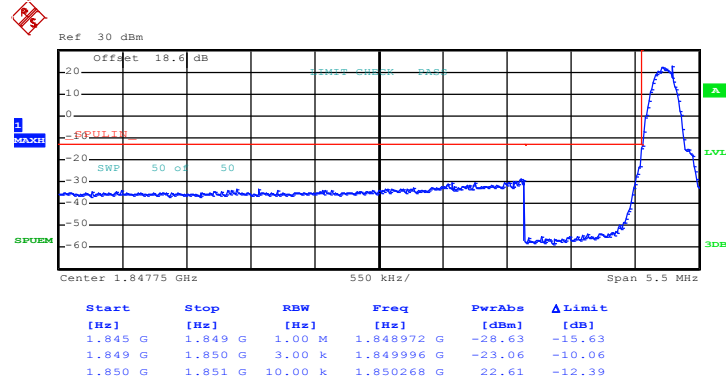

Date: 8.MAY.2015 19:47:02

Higher Band Edge Plot on Channel 810 (1909.8 MHz)

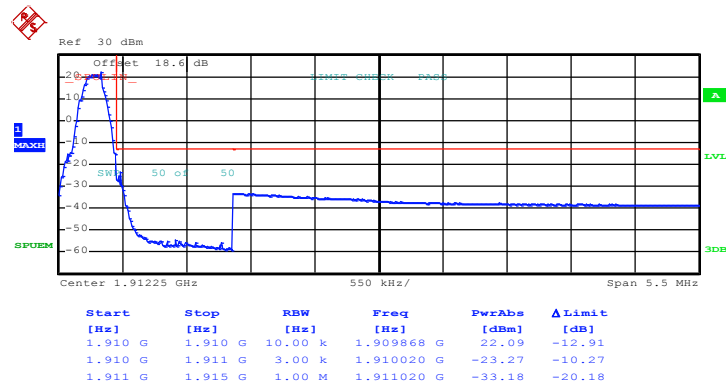

Date: 8.MAY.2015 19:48:25



Band :	GSM1900	Test Mode :	EDGE class 8 Link (8PSK)
--------	---------	-------------	--------------------------

Lower Band Edge Plot on Channel 512 (1850.2 MHz)

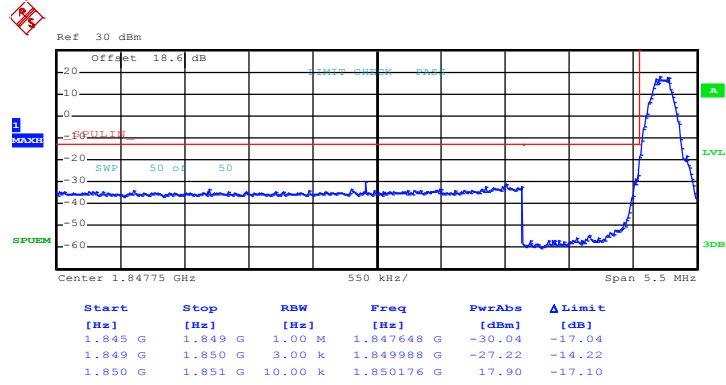

Date: 8.MAY.2015 19:33:35

Higher Band Edge Plot on Channel 810 (1909.8 MHz)

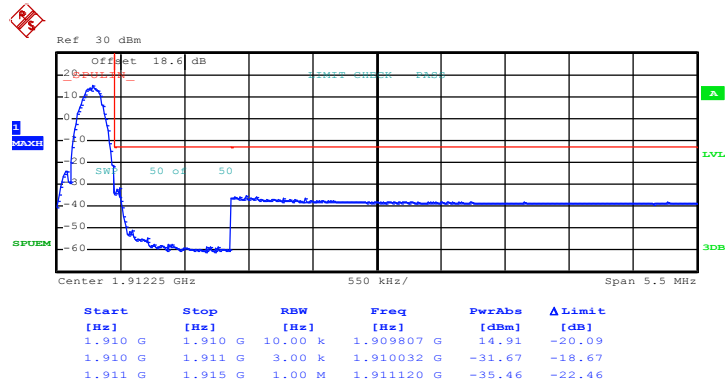

Date: 8.MAY.2015 19:34:58



Band :	WCDMA Band V	Test Mode :	RMC 12.2Kbps Link (QPSK)
--------	--------------	-------------	--------------------------

Lower Band Edge Plot on Channel 4132 (826.4 MHz)

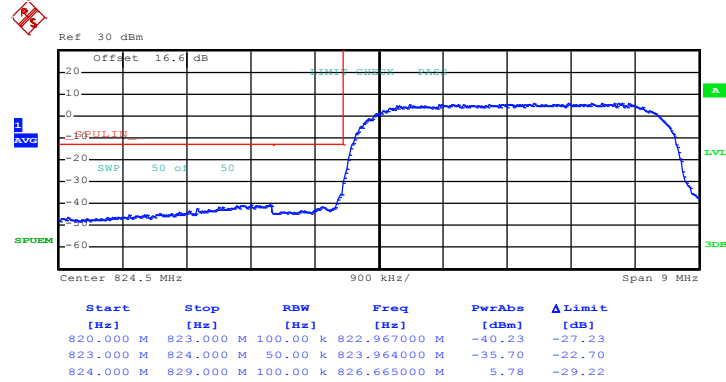

Date: 8.MAY.2015 19:59:13

Higher Band Edge Plot on Channel 4233 (846.6 MHz)

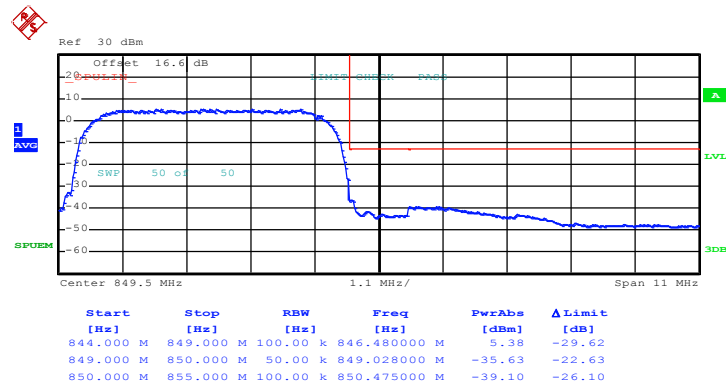

Date: 8.MAY.2015 20:00:36



<b>Band :</b>	WCDMA Band IV	<b>Test Mode :</b>	RMC 12.2Kbps Link (QPSK)
---------------	---------------	--------------------	--------------------------

Lower Band Edge Plot on Channel 1312 (1712.4 MHz)

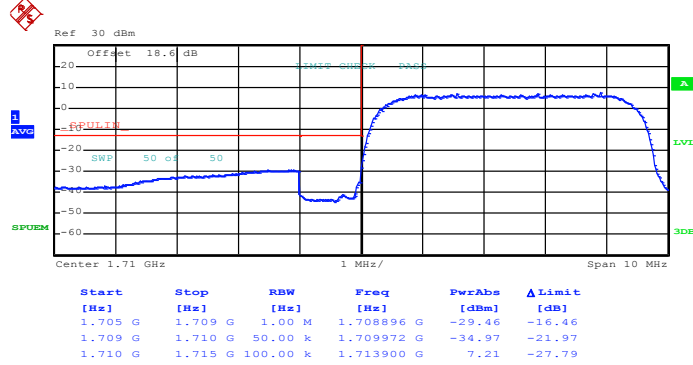

Date: 8.MAY.2015 20:20:55

Higher Band Edge Plot on Channel 1513 (1752.6 MHz)

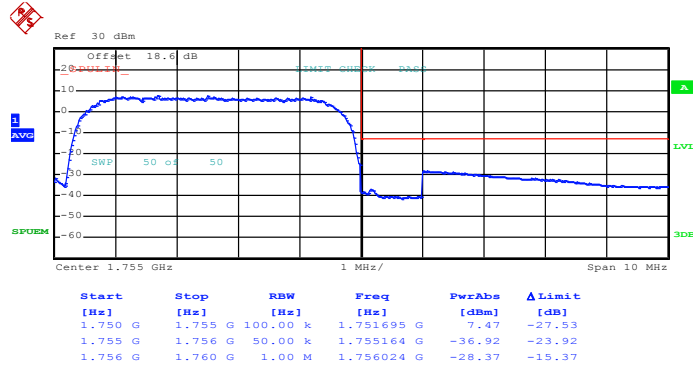

Date: 8.MAY.2015 20:22:18



Band :	WCDMA Band II	Test Mode :	RMC 12.2Kbps Link (QPSK)
--------	---------------	-------------	--------------------------

Lower Band Edge Plot on Channel 9262 (1852.4 MHz)

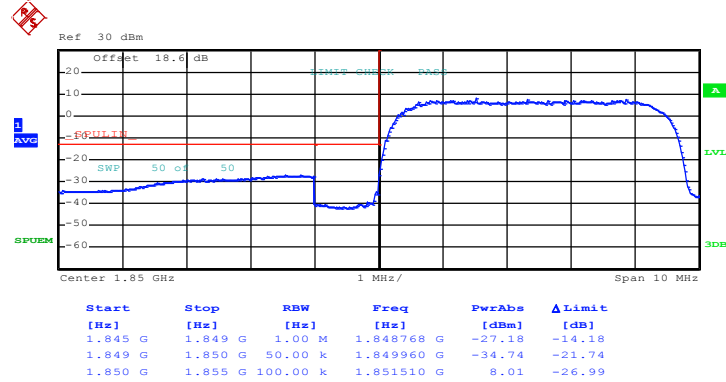

Date: 8.MAY.2015 20:09:48

Higher Band Edge Plot on Channel 9538 (1907.6 MHz)

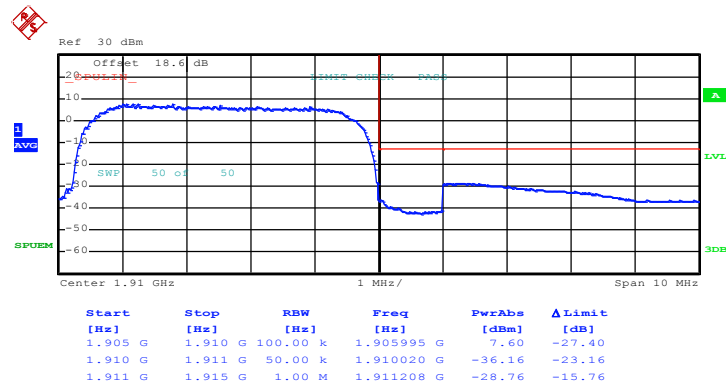

Date: 8.MAY.2015 20:11:10

### 3.6 Conducted Spurious Emission Measurement

#### 3.6.1 Description of Conducted Spurious Emission Measurement

The power of any emission outside of the authorized operating frequency ranges must be lower than the transmitter power (P) by a factor of at least  $43 + 10 \log (P)$  dB.

It is measured by means of a calibrated spectrum analyzer and scanned from 30 MHz up to a frequency including its 10<sup>th</sup> harmonic.

#### 3.6.2 Measuring Instruments

The measuring equipment is listed in the section 4 of this test report.

#### 3.6.3 Test Procedures

1. The testing follows FCC KDB 971168 v02r02 Section 6.0.
2. The EUT was connected to the spectrum analyzer and system simulator via a power divider.
3. The RF output of EUT was connected to the spectrum analyzer by an RF cable and attenuator. The path loss was compensated to the results for each measurement.
4. The middle channel for the highest RF power within the transmitting frequency was measured.
5. The conducted spurious emission for the whole frequency range was taken.
6. The RF fundamental frequency should be excluded against the limit line in the operating frequency band.
7. The limit line is derived from  $43 + 10\log(P)$  dB below the transmitter power P(Watts)
  - =  $P(W) - [43 + 10\log(P)]$  (dB)
  - =  $[30 + 10\log(P)]$  (dBm) -  $[43 + 10\log(P)]$  (dB)
  - = -13dBm.

#### 3.6.4 Test Setup

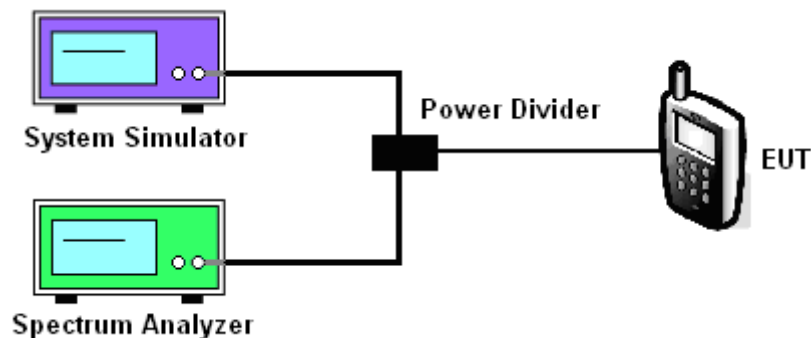



### 3.6.5 Test Result (Plots) of Conducted Spurious Emission

Band :	GSM850	Channel :	CH128
Test Mode :	GSM Link (GMSK)	Frequency :	824.2 MHz

Conducted Spurious Emission Plot between 30MHz ~ 9GHz

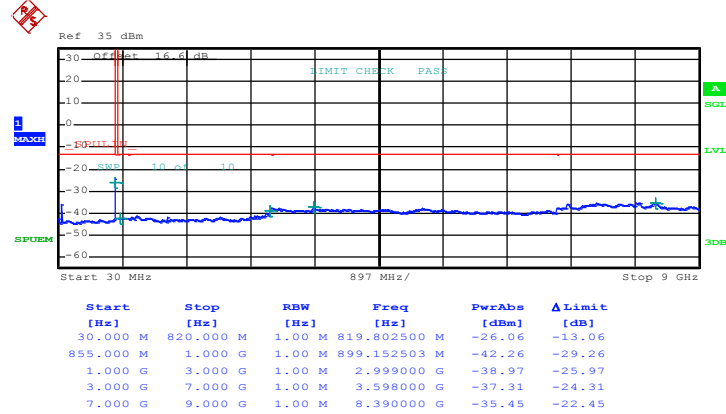

Date: 8.MAY.2015 18:58:14



<b>Band :</b>	GSM850	<b>Channel :</b>	CH189
<b>Test Mode :</b>	GSM Link (GMSK)	<b>Frequency :</b>	836.4 MHz

Conducted Spurious Emission Plot between 30MHz ~ 9GHz

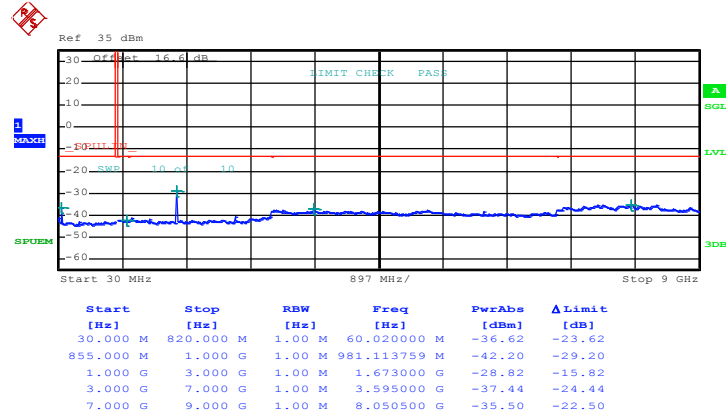

Date: 8.MAY.2015 18:58:39



<b>Band :</b>	GSM850	<b>Channel :</b>	CH251
<b>Test Mode :</b>	GSM Link (GMSK)	<b>Frequency :</b>	848.8 MHz

**Conducted Spurious Emission Plot between 30MHz ~ 9GHz**

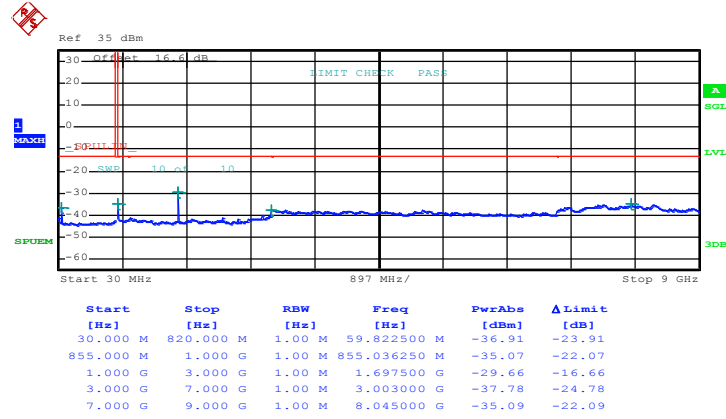

Date: 8.MAY.2015 18:59:04



<b>Band :</b>	GSM850	<b>Channel :</b>	CH128
<b>Test Mode :</b>	EDGE class 8 Link (8PSK)	<b>Frequency :</b>	824.2 MHz

Conducted Spurious Emission Plot between 30MHz ~ 9GHz

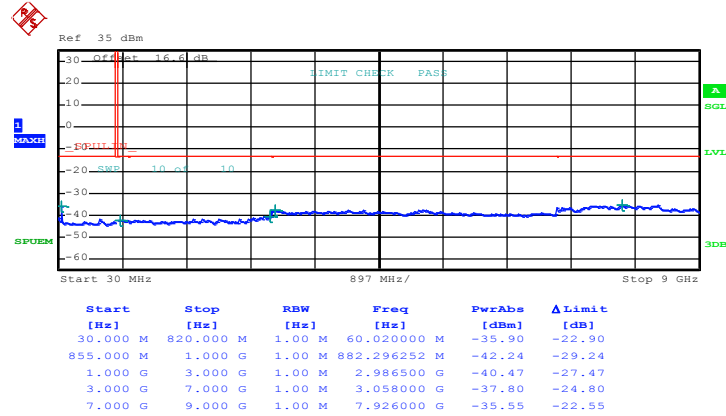

Date: 8.MAY.2015 19:13:32



<b>Band :</b>	GSM850	<b>Channel :</b>	CH189
<b>Test Mode :</b>	EDGE class 8 Link (8PSK)	<b>Frequency :</b>	836.4 MHz

Conducted Spurious Emission Plot between 30MHz ~ 9GHz

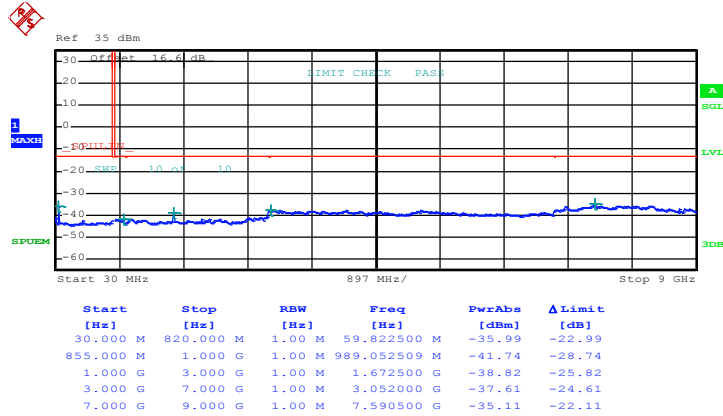

Date: 8.MAY.2015 19:13:57



<b>Band :</b>	GSM850	<b>Channel :</b>	CH251
<b>Test Mode :</b>	EDGE class 8 Link (8PSK)	<b>Frequency :</b>	848.8 MHz

Conducted Spurious Emission Plot between 30MHz ~ 9GHz

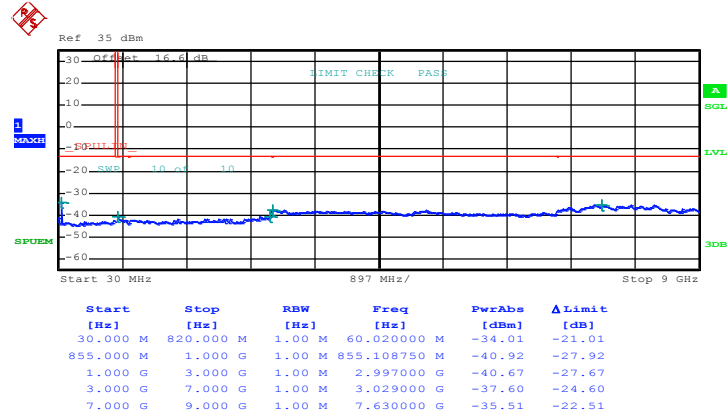

Date: 8.MAY.2015 19:14:22



<b>Band :</b>	GSM1900	<b>Channel :</b>	CH512
<b>Test Mode :</b>	GSM Link (GMSK)	<b>Frequency :</b>	1850.2 MHz

Conducted Spurious Emission Plot between 30MHz ~ 19.1GHz

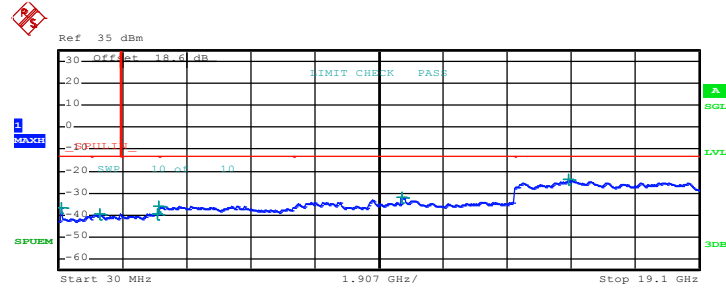

Start [Hz]	Stop [Hz]	RBW [Hz]	Freq [Hz]	PwrAbs [dBm]	Δ Limit [dB]
30.000 M	1.000 G	1.00 M	111.965000 M	-36.41	-23.41
1.000 G	1.845 G	1.00 M	1.233431 G	-39.61	-26.61
1.915 G	3.000 G	1.00 M	2.981826 G	-39.28	-26.28
3.000 G	7.000 G	1.00 M	3.015000 G	-35.84	-22.84
7.000 G	13.600 G	1.00 M	10.243075 G	-32.21	-19.21
13.600 G	19.100 G	1.00 M	15.206687 G	-23.82	-10.82

Date: 8.MAY.2015 19:48:59



<b>Band :</b>	GSM1900	<b>Channel :</b>	CH661
<b>Test Mode :</b>	GSM Link (GMSK)	<b>Frequency :</b>	1880.0 MHz

Conducted Spurious Emission Plot between 30MHz ~ 19.1GHz

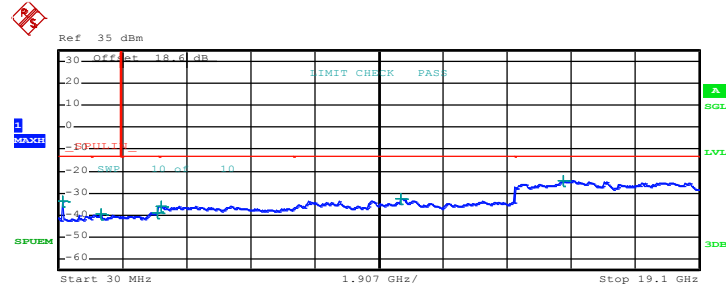

Start [Hz]	Stop [Hz]	RBW [Hz]	Freq [Hz]	PwrAbs [dBm]	Δ Limit [dB]
30.000 M	1.000 G	1.00 M	141.792500 M	-33.54	-20.54
1.000 G	1.845 G	1.00 M	1.300186 G	-39.51	-26.51
1.915 G	3.000 G	1.00 M	2.977215 G	-38.93	-25.93
3.000 G	7.000 G	1.00 M	3.094000 G	-35.81	-22.81
7.000 G	13.600 G	1.00 M	10.216675 G	-32.45	-19.45
13.600 G	19.100 G	1.00 M	15.039625 G	-24.38	-11.38

Date: 8.MAY.2015 19:49:24



<b>Band :</b>	GSM1900	<b>Channel :</b>	CH810
<b>Test Mode :</b>	GSM Link (GMSK)	<b>Frequency :</b>	1909.8 MHz

Conducted Spurious Emission Plot between 30MHz ~ 19.1GHz

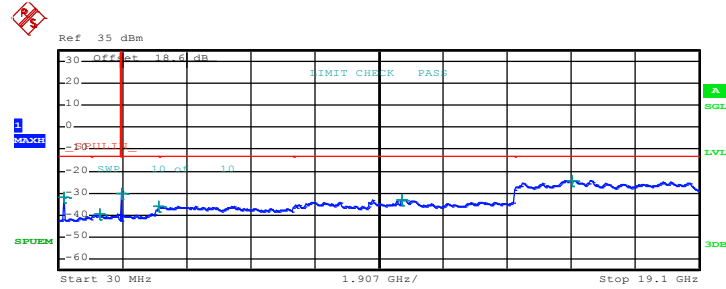

Start [Hz]	Stop [Hz]	RBW [Hz]	Freq [Hz]	PwrAbs [dBm]	Δ Limit [dB]
30.000 M	1.000 G	1.00 M	171.620000 M	-32.07	-19.07
1.000 G	1.845 G	1.00 M	1.257303 G	-39.64	-26.64
1.915 G	3.000 G	1.00 M	1.915271 G	-29.94	-16.94
3.000 G	7.000 G	1.00 M	3.012000 G	-35.99	-22.99
7.000 G	13.600 G	1.00 M	10.256275 G	-32.99	-19.99
13.600 G	19.100 G	1.00 M	15.338688 G	-24.26	-11.26

Date: 8.MAY.2015 19:49:50



<b>Band :</b>	GSM1900	<b>Channel :</b>	CH512
<b>Test Mode :</b>	EDGE class 8 Link (8PSK)	<b>Frequency :</b>	1850.2 MHz

Conducted Spurious Emission Plot between 30MHz ~ 19.1GHz

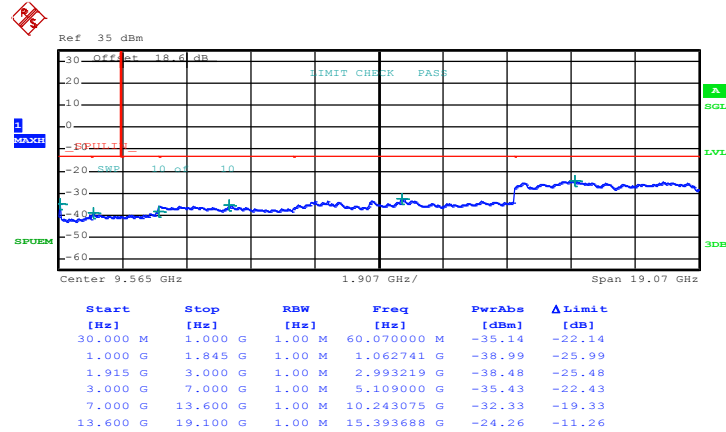

Date: 8.MAY.2015 19:37:52



<b>Band :</b>	GSM1900	<b>Channel :</b>	CH661
<b>Test Mode :</b>	EDGE class 8 Link (8PSK)	<b>Frequency :</b>	1880.0 MHz

Conducted Spurious Emission Plot between 30MHz ~ 19.1GHz

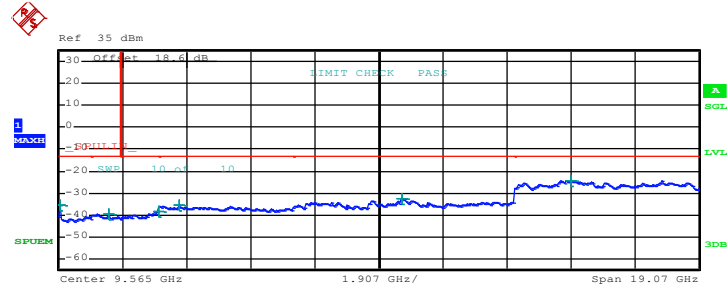

Start [Hz]	Stop [Hz]	RBW [Hz]	Freq [Hz]	PwrAbs [dBm]	Δ Limit [dB]
30.000 M	1.000 G	1.00 M	60.070000 M	-35.76	-22.76
1.000 G	1.845 G	1.00 M	1.517562 G	-39.54	-26.54
1.915 G	3.000 G	1.00 M	2.999186 G	-38.21	-25.21
3.000 G	7.000 G	1.00 M	3.610000 G	-35.32	-22.32
7.000 G	13.600 G	1.00 M	10.236475 G	-32.72	-19.72
13.600 G	19.100 G	1.00 M	15.297437 G	-24.10	-11.10

Date: 8.MAY.2015 19:38:41



<b>Band :</b>	GSM1900	<b>Channel :</b>	CH810
<b>Test Mode :</b>	EDGE class 8 Link (8PSK)	<b>Frequency :</b>	1909.8 MHz

Conducted Spurious Emission Plot between 30MHz ~ 19.1GHz

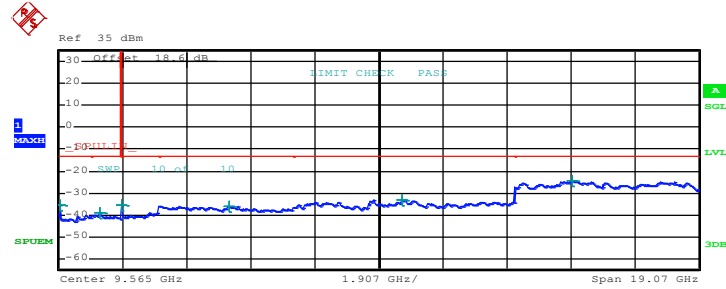

Start [Hz]	Stop [Hz]	RBW [Hz]	Freq [Hz]	PwrAbs [dBm]	Δ Limit [dB]
30.000 M	1.000 G	1.00 M	60.070000 M	-35.31	-22.31
1.000 G	1.845 G	1.00 M	1.256880 G	-39.09	-26.09
1.915 G	3.000 G	1.00 M	1.915271 G	-35.51	-22.51
3.000 G	7.000 G	1.00 M	5.117000 G	-35.88	-22.88
7.000 G	13.600 G	1.00 M	10.233175 G	-33.00	-20.00
13.600 G	19.100 G	1.00 M	15.313938 G	-24.45	-11.45

Date: 8.MAY.2015 19:39:09



<b>Band :</b>	WCDMA Band V	<b>Channel :</b>	CH4132
<b>Test Mode :</b>	RMC 12.2Kbps Link (QPSK)	<b>Frequency :</b>	826.4 MHz

Conducted Spurious Emission Plot between 30MHz ~ 9GHz

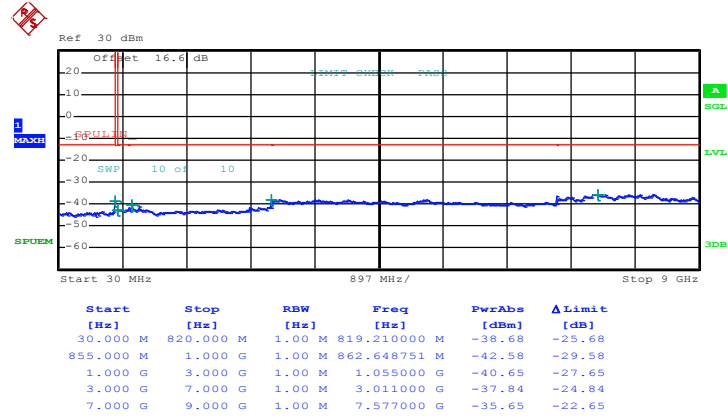

Date: 8.MAY.2015 20:01:39



<b>Band :</b>	WCDMA Band V	<b>Channel :</b>	CH4182
<b>Test Mode :</b>	RMC 12.2Kbps Link (QPSK)	<b>Frequency :</b>	836.4 MHz

Conducted Spurious Emission Plot between 30MHz ~ 9GHz

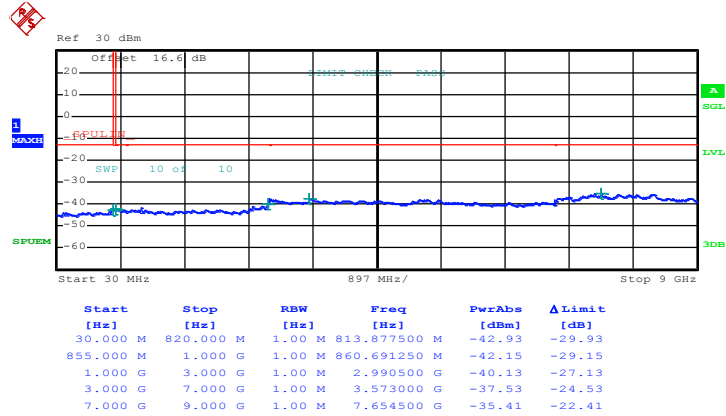

Date: 8.MAY.2015 20:02:04



<b>Band :</b>	WCDMA Band V	<b>Channel :</b>	CH4233
<b>Test Mode :</b>	RMC 12.2Kbps Link (QPSK)	<b>Frequency :</b>	846.6 MHz

Conducted Spurious Emission Plot between 30MHz ~ 9GHz

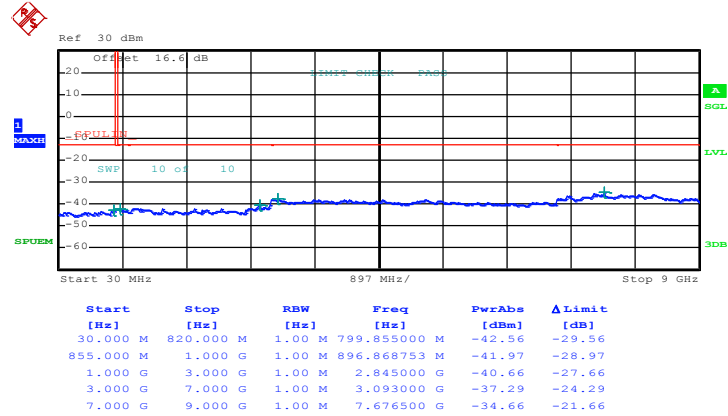

Date: 8.MAY.2015 20:02:29



<b>Band :</b>	WCDMA Band IV	<b>Channel :</b>	CH1312
<b>Test Mode :</b>	RMC 12.2Kbps Link (QPSK)	<b>Frequency :</b>	1712.4 MHz

Conducted Spurious Emission Plot between 30MHz ~ 18GHz

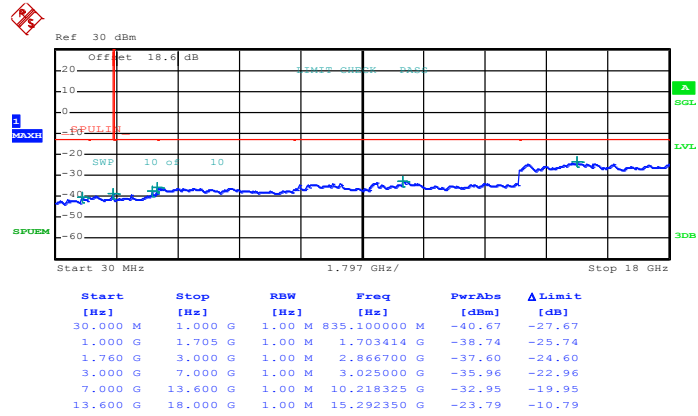

Date: 8.MAY.2015 20:23:49



<b>Band :</b>	WCDMA Band IV	<b>Channel :</b>	CH1413
<b>Test Mode :</b>	RMC 12.2Kbps Link (QPSK)	<b>Frequency :</b>	1732.6 MHz

Conducted Spurious Emission Plot between 30MHz ~ 18GHz

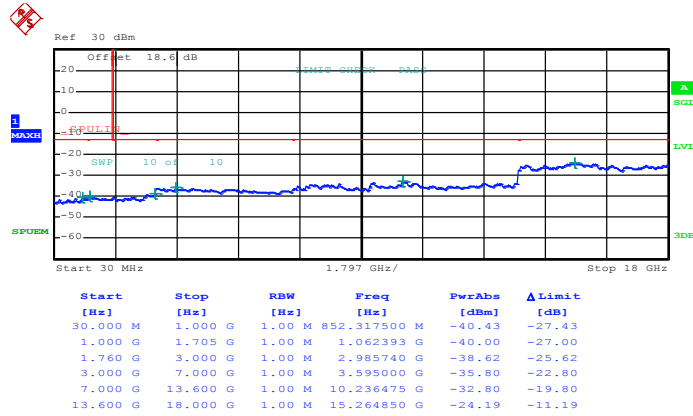

Date: 8.MAY.2015 20:24:14



<b>Band :</b>	WCDMA Band IV	<b>Channel :</b>	CH1513
<b>Test Mode :</b>	RMC 12.2Kbps Link (QPSK)	<b>Frequency :</b>	1752.6 MHz

**Conducted Spurious Emission Plot between 30MHz ~ 18GHz**

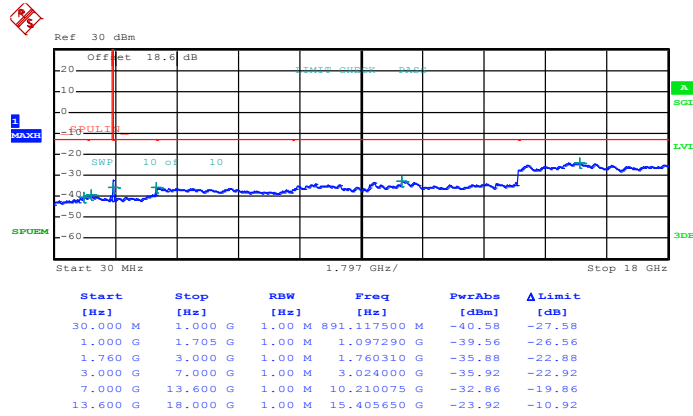

Date: 8.MAY.2015 20:24:39



<b>Band :</b>	WCDMA Band II	<b>Channel :</b>	CH9262
<b>Test Mode :</b>	RMC 12.2Kbps Link (QPSK)	<b>Frequency :</b>	1852.4 MHz

**Conducted Spurious Emission Plot between 30MHz ~ 19.1GHz**

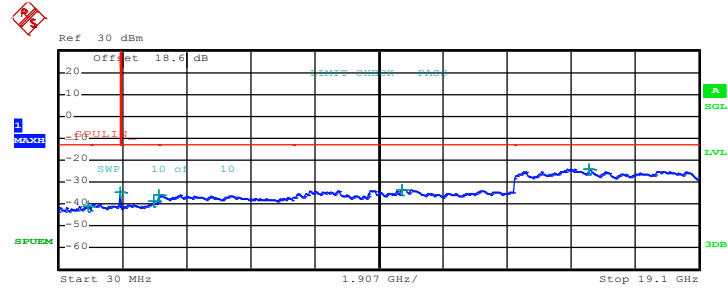

Start [Hz]	Stop [Hz]	RBW [Hz]	Freq [Hz]	PwrAbs [dBm]	Δ Limit [dB]
30.000 M	1.000 G	1.00 M	909.790000 M	-40.82	-27.82
1.000 G	1.845 G	1.00 M	1.844789 G	-34.79	-21.79
1.915 G	3.000 G	1.00 M	2.840776 G	-38.90	-25.90
3.000 G	7.000 G	1.00 M	3.018000 G	-35.70	-22.70
7.000 G	13.600 G	1.00 M	10.237300 G	-33.31	-20.31
13.600 G	19.100 G	1.00 M	15.838500 G	-24.13	-11.13

Date: 8.MAY.2015 20:11:45



<b>Band :</b>	WCDMA Band II	<b>Channel :</b>	CH9400
<b>Test Mode :</b>	RMC 12.2Kbps Link (QPSK)	<b>Frequency :</b>	1880.0 MHz

Conducted Spurious Emission Plot between 30MHz ~ 19.1GHz

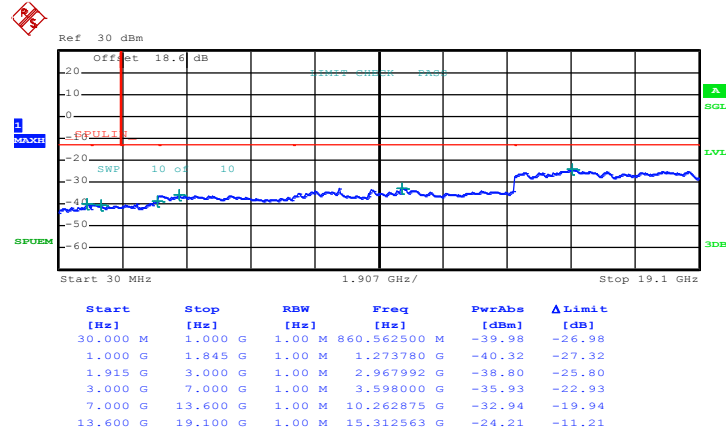

Date: 8.MAY.2015 20:12:11



Band :	WCDMA Band II	Channel :	CH9538
Test Mode :	RMC 12.2Kbps Link (QPSK)	Frequency :	1907.6 MHz

Conducted Spurious Emission Plot between 30MHz ~ 19.1GHz

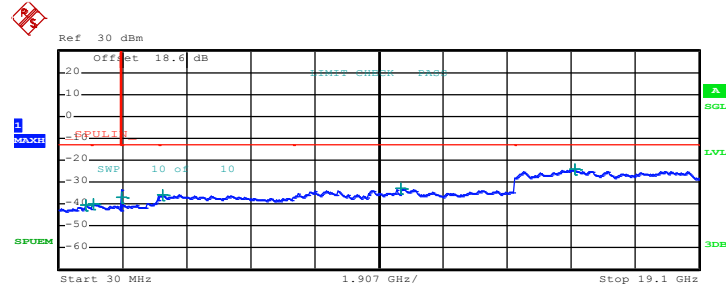

Date: 8.MAY.2015 20:12:36



### 3.7 Field Strength of Spurious Radiation Measurement

#### 3.7.1 Description of Field Strength of Spurious Radiated Measurement

The power of any emission outside of the authorized operating frequency ranges must be attenuated below the transmitter power (P) by a factor of at least  $43 + 10 \log (P)$  dB. The spectrum is scanned from 30 MHz up to a frequency including its 10th harmonic.

#### 3.7.2 Measuring Instruments

The measuring equipment is listed in the section 4 of this test report.

#### 3.7.3 Test Procedures

1. The testing follows FCC KDB 971168 v02r02 Section 5.8 and ANSI / TIA-603-C-2004 Section 2.2.12.
2. The EUT was placed on a rotatable wooden table 0.8 meters above the ground.
3. The EUT was set 3 meters from the receiving antenna, which was mounted on the antenna tower.
4. The table was rotated 360 degrees to determine the position of the highest spurious emission.
5. The height of the receiving antenna is varied between one meter and four meters to search for the maximum spurious emission for both horizontal and vertical polarizations.
6. Make the measurement with the spectrum analyzer's RBW = 1MHz, VBW = 3MHz, taking record of maximum spurious emission.
7. A horn antenna was substituted in place of the EUT and was driven by a signal generator.
8. Tune the output power of signal generator to the same emission level with EUT maximum spurious emission.
9. Taking the record of output power at antenna port.
10. Repeat step 7 to step 8 for another polarization.
11.  $EIRP (dBm) = S.G. Power - Tx Cable Loss + Tx Antenna Gain$
12.  $ERP (dBm) = EIRP - 2.15$
13. The RF fundamental frequency should be excluded against the limit line in the operating frequency band.
14. The limit line is derived from  $43 + 10\log(P)$  dB below the transmitter power P(Watts)  
=  $P(W) - [43 + 10\log(P)] (dB)$   
=  $[30 + 10\log(P)] (dBm) - [43 + 10\log(P)] (dB)$   
= -13dBm.

### 3.7.4 Test Setup

For radiated emissions from 30MHz to 1GHz

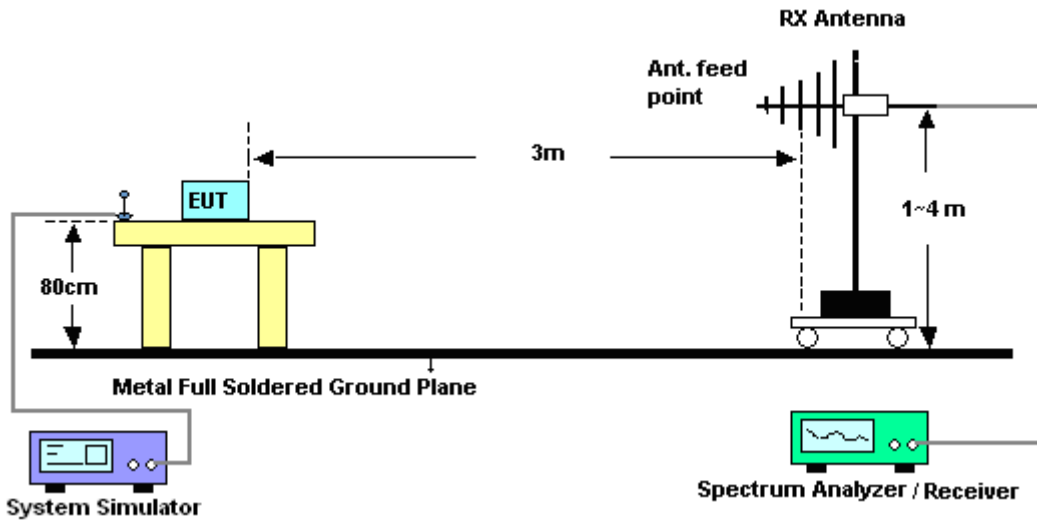

For radiated emissions above 1GHz

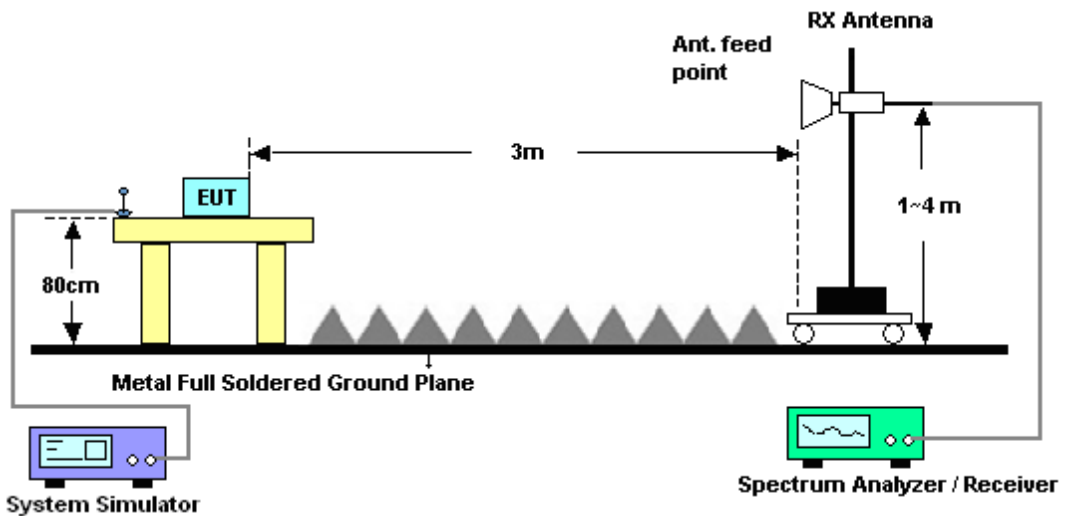



3.7.5 Test Result of Field Strength of Spurious Radiated

<Low Channel>

<b>Band :</b>	GSM850		<b>Temperature :</b>	23~24°C					
<b>Test Mode :</b>	GSM Link (GMSK)		<b>Relative Humidity :</b>	46~48%					
<b>Test Engineer :</b>	Derreck Chen		<b>Polarization :</b>	Horizontal					
<b>Remark :</b>	Spurious emissions within 30-1000MHz were found more than 20dB below limit line.								
Frequency ( MHz )	ERP ( dBm )	Limit ( dBm )	Over Limit ( dB )	SPA Reading ( dBm )	S.G. Power ( dBm )	TX Cable loss ( dB )	TX Antenna Gain ( dBi )	Polarization ( H/V )	Result
1648	-55.22	-13	-42.22	-59.39	-56.98	0.98	4.89	H	Pass
2472	-59.97	-13	-46.97	-69.13	-61.85	1.28	5.32	H	Pass
3296	-64.17	-13	-51.17	-76.02	-67.58	1.54	7.10	H	Pass

<b>Band :</b>	GSM850		<b>Temperature :</b>	23~24°C					
<b>Test Mode :</b>	GSM Link (GMSK)		<b>Relative Humidity :</b>	46~48%					
<b>Test Engineer :</b>	Derreck Chen		<b>Polarization :</b>	Vertical					
<b>Remark :</b>	Spurious emissions within 30-1000MHz were found more than 20dB below limit line.								
Frequency ( MHz )	ERP ( dBm )	Limit ( dBm )	Over Limit ( dB )	SPA Reading ( dBm )	S.G. Power ( dBm )	TX Cable loss ( dB )	TX Antenna Gain ( dBi )	Polarization ( H/V )	Result
1648	-59.82	-13	-46.82	-62.55	-61.58	0.98	4.89	V	Pass
2472	-61.61	-13	-48.61	-71.92	-63.49	1.28	5.32	V	Pass
3296	-65.16	-13	-52.16	-76.12	-68.57	1.54	7.10	V	Pass



<Middle Channel>

<b>Band :</b>	GSM850		<b>Temperature :</b>	23~24°C					
<b>Test Mode :</b>	GSM Link (GMSK)		<b>Relative Humidity :</b>	46~48%					
<b>Test Engineer :</b>	Derreck Chen		<b>Polarization :</b>	Horizontal					
<b>Remark :</b>	Spurious emissions within 30-1000MHz were found more than 20dB below limit line.								
Frequency ( MHz )	ERP ( dBm )	Limit ( dBm )	Over Limit ( dB )	SPA Reading ( dBm )	S.G. Power ( dBm )	TX Cable loss ( dB )	TX Antenna Gain ( dBi )	Polarization ( H/V )	Result
1672	-62.83	-13	-49.83	-66.63	-64.51	0.99	4.82	H	Pass
2512	-57.02	-13	-44.02	-66.17	-58.99	1.29	5.41	H	Pass
3345	-64.02	-13	-51.02	-76	-67.63	1.56	7.32	H	Pass

<b>Band :</b>	GSM850		<b>Temperature :</b>	23~24°C					
<b>Test Mode :</b>	GSM Link (GMSK)		<b>Relative Humidity :</b>	46~48%					
<b>Test Engineer :</b>	Derreck Chen		<b>Polarization :</b>	Vertical					
<b>Remark :</b>	Spurious emissions within 30-1000MHz were found more than 20dB below limit line.								
Frequency ( MHz )	ERP ( dBm )	Limit ( dBm )	Over Limit ( dB )	SPA Reading ( dBm )	S.G. Power ( dBm )	TX Cable loss ( dB )	TX Antenna Gain ( dBi )	Polarization ( H/V )	Result
1672	-63.54	-13	-50.54	-66.21	-65.22	0.99	4.82	V	Pass
2512	-57.69	-13	-44.69	-67.57	-59.66	1.29	5.41	V	Pass
4184	-64.95	-13	-51.95	-76.1	-69.57	1.87	8.64	V	Pass



<High Channel>

<b>Band :</b>	GSM850		<b>Temperature :</b>	23~24°C					
<b>Test Mode :</b>	GSM Link (GMSK)		<b>Relative Humidity :</b>	46~48%					
<b>Test Engineer :</b>	Derreck Chen		<b>Polarization :</b>	Horizontal					
<b>Remark :</b>	Spurious emissions within 30-1000MHz were found more than 20dB below limit line.								
Frequency ( MHz )	ERP ( dBm )	Limit ( dBm )	Over Limit ( dB )	SPA Reading ( dBm )	S.G. Power ( dBm )	TX Cable loss ( dB )	TX Antenna Gain ( dBi )	Polarization ( H/V )	Result
1696	-59.68	-13	-46.68	-63.74	-61.28	1.00	4.75	H	Pass
2544	-52.98	-13	-39.98	-62.03	-54.96	1.30	5.44	H	Pass
3392	-64.77	-13	-51.77	-76.31	-68.57	1.57	7.52	H	Pass

<b>Band :</b>	GSM850		<b>Temperature :</b>	23~24°C					
<b>Test Mode :</b>	GSM Link (GMSK)		<b>Relative Humidity :</b>	46~48%					
<b>Test Engineer :</b>	Derreck Chen		<b>Polarization :</b>	Vertical					
<b>Remark :</b>	Spurious emissions within 30-1000MHz were found more than 20dB below limit line.								
Frequency ( MHz )	ERP ( dBm )	Limit ( dBm )	Over Limit ( dB )	SPA Reading ( dBm )	S.G. Power ( dBm )	TX Cable loss ( dB )	TX Antenna Gain ( dBi )	Polarization ( H/V )	Result
1696	-64.25	-13	-51.25	-67.75	-65.85	1.00	4.75	V	Pass
2544	-59.71	-13	-46.71	-69.44	-61.69	1.30	5.44	V	Pass
3392	-64.77	-13	-51.77	-76.52	-68.57	1.57	7.52	V	Pass



<Low Channel>

<b>Band :</b>	GSM850		<b>Temperature :</b>	23~24°C					
<b>Test Mode :</b>	EDGE class 8 Link (8PSK)		<b>Relative Humidity :</b>	46~48%					
<b>Test Engineer :</b>	Derreck Chen		<b>Polarization :</b>	Horizontal					
<b>Remark :</b>	Spurious emissions within 30-1000MHz were found more than 20dB below limit line.								
Frequency ( MHz )	ERP ( dBm )	Limit ( dBm )	Over Limit ( dB )	SPA Reading ( dBm )	S.G. Power ( dBm )	TX Cable loss ( dB )	TX Antenna Gain ( dBi )	Polarization ( H/V )	Result
1648	-52.82	-13	-39.82	-57.18	-54.58	0.98	4.89	H	Pass
2472	-65.61	-13	-52.61	-75.02	-67.49	1.28	5.32	H	Pass
3296	-64.41	-13	-51.41	-76.4	-67.82	1.54	7.10	H	Pass

<b>Band :</b>	GSM850		<b>Temperature :</b>	23~24°C					
<b>Test Mode :</b>	EDGE class 8 Link (8PSK)		<b>Relative Humidity :</b>	46~48%					
<b>Test Engineer :</b>	Derreck Chen		<b>Polarization :</b>	Vertical					
<b>Remark :</b>	Spurious emissions within 30-1000MHz were found more than 20dB below limit line.								
Frequency ( MHz )	ERP ( dBm )	Limit ( dBm )	Over Limit ( dB )	SPA Reading ( dBm )	S.G. Power ( dBm )	TX Cable loss ( dB )	TX Antenna Gain ( dBi )	Polarization ( H/V )	Result
1648	-61.76	-13	-48.76	-64.51	-63.52	0.98	4.89	V	Pass
2472	-64.95	-13	-51.95	-75.23	-66.83	1.28	5.32	V	Pass
3296	-65.06	-13	-52.06	-76.11	-68.47	1.54	7.10	V	Pass



<Middle Channel>

<b>Band :</b>	GSM850				<b>Temperature :</b>	23~24°C			
<b>Test Mode :</b>	EDGE class 8 Link (8PSK)				<b>Relative Humidity :</b>	46~48%			
<b>Test Engineer :</b>	Derreck Chen				<b>Polarization :</b>	Horizontal			
<b>Remark :</b>	Spurious emissions within 30-1000MHz were found more than 20dB below limit line.								
Frequency ( MHz )	ERP ( dBm )	Limit ( dBm )	Over Limit ( dB )	SPA Reading ( dBm )	S.G. Power ( dBm )	TX Cable loss ( dB )	TX Antenna Gain ( dBi )	Polarization ( H/V )	Result
1672	-62.16	-13	-49.16	-66.43	-63.84	0.99	4.82	H	Pass
2512	-66.24	-13	-53.24	-75.07	-68.21	1.29	5.41	H	Pass
3344	-64.81	-13	-51.81	-76.48	-68.42	1.56	7.31	H	Pass

<b>Band :</b>	GSM850				<b>Temperature :</b>	23~24°C			
<b>Test Mode :</b>	EDGE class 8 Link (8PSK)				<b>Relative Humidity :</b>	46~48%			
<b>Test Engineer :</b>	Derreck Chen				<b>Polarization :</b>	Vertical			
<b>Remark :</b>	Spurious emissions within 30-1000MHz were found more than 20dB below limit line.								
Frequency ( MHz )	ERP ( dBm )	Limit ( dBm )	Over Limit ( dB )	SPA Reading ( dBm )	S.G. Power ( dBm )	TX Cable loss ( dB )	TX Antenna Gain ( dBi )	Polarization ( H/V )	Result
1672	-66.89	-13	-53.89	-69.73	-68.57	0.99	4.82	V	Pass
2512	-65.01	-13	-52.01	-75.08	-66.98	1.29	5.41	V	Pass
3344	-65.24	-13	-52.24	-76.37	-68.85	1.56	7.31	V	Pass



<High Channel>

<b>Band :</b>	GSM850		<b>Temperature :</b>	23~24°C					
<b>Test Mode :</b>	EDGE class 8 Link (8PSK)		<b>Relative Humidity :</b>	46~48%					
<b>Test Engineer :</b>	Derreck Chen		<b>Polarization :</b>	Horizontal					
<b>Remark :</b>	Spurious emissions within 30-1000MHz were found more than 20dB below limit line.								
Frequency ( MHz )	ERP ( dBm )	Limit ( dBm )	Over Limit ( dB )	SPA Reading ( dBm )	S.G. Power ( dBm )	TX Cable loss ( dB )	TX Antenna Gain ( dBi )	Polarization ( H/V )	Result
1696	-67.33	-13	-54.33	-71.64	-68.93	1.00	4.75	H	Pass
2546	-63.88	-13	-50.88	-73.29	-65.86	1.31	5.44	H	Pass
3395	-64.13	-13	-51.13	-76.21	-67.95	1.57	7.54	H	Pass

<b>Band :</b>	GSM850		<b>Temperature :</b>	23~24°C					
<b>Test Mode :</b>	EDGE class 8 Link (8PSK)		<b>Relative Humidity :</b>	46~48%					
<b>Test Engineer :</b>	Derreck Chen		<b>Polarization :</b>	Vertical					
<b>Remark :</b>	Spurious emissions within 30-1000MHz were found more than 20dB below limit line.								
Frequency ( MHz )	ERP ( dBm )	Limit ( dBm )	Over Limit ( dB )	SPA Reading ( dBm )	S.G. Power ( dBm )	TX Cable loss ( dB )	TX Antenna Gain ( dBi )	Polarization ( H/V )	Result
1696	-68.69	-13	-55.69	-72.33	-70.29	1.00	4.75	V	Pass
2546	-65.11	-13	-52.11	-74.88	-69.24	1.31	5.44	V	Pass
3395	-64.65	-13	-51.65	-76.18	-70.62	1.57	7.54	V	Pass



<Low Channel>

<b>Band :</b>	GSM1900				<b>Temperature :</b>	23~24°C			
<b>Test Mode :</b>	GSM Link (GMSK)				<b>Relative Humidity :</b>	46~48%			
<b>Test Engineer :</b>	Derreck Chen				<b>Polarization :</b>	Horizontal			
<b>Remark :</b>	Spurious emissions within 30-1000MHz were found more than 20dB below limit line.								
Frequency ( MHz )	EIRP ( dBm )	Limit ( dBm )	Over Limit ( dB )	SPA Reading ( dBm )	S.G. Power ( dBm )	TX Cable loss ( dB )	TX Antenna Gain ( dBi )	Polarization ( H/V )	Result
3700	-46.44	-13	-33.44	-60.56	-53.01	1.67	8.24	H	Pass
5548	-38.85	-13	-25.85	-58.32	-45.92	2.65	9.72	H	Pass
7400	-52.94	-13	-39.94	-77.72	-62.08	2.46	11.60	H	Pass

<b>Band :</b>	GSM1900				<b>Temperature :</b>	23~24°C			
<b>Test Mode :</b>	GSM Link (GMSK)				<b>Relative Humidity :</b>	46~48%			
<b>Test Engineer :</b>	Derreck Chen				<b>Polarization :</b>	Vertical			
<b>Remark :</b>	Spurious emissions within 30-1000MHz were found more than 20dB below limit line.								
Frequency ( MHz )	EIRP ( dBm )	Limit ( dBm )	Over Limit ( dB )	SPA Reading ( dBm )	S.G. Power ( dBm )	TX Cable loss ( dB )	TX Antenna Gain ( dBi )	Polarization ( H/V )	Result
3700	-44.61	-13	-31.61	-58.46	-51.18	1.67	8.24	V	Pass
5548	-40.25	-13	-27.25	-58.65	-47.32	2.65	9.72	V	Pass
7400	-54.40	-13	-41.40	-77.83	-63.54	2.46	11.60	V	Pass



<Middle Channel>

<b>Band :</b>	GSM1900		<b>Temperature :</b>	23~24°C					
<b>Test Mode :</b>	GSM Link (GMSK)		<b>Relative Humidity :</b>	46~48%					
<b>Test Engineer :</b>	Derreck Chen		<b>Polarization :</b>	Horizontal					
<b>Remark :</b>	Spurious emissions within 30-1000MHz were found more than 20dB below limit line.								
Frequency ( MHz )	EIRP ( dBm )	Limit ( dBm )	Over Limit ( dB )	SPA Reading ( dBm )	S.G. Power ( dBm )	TX Cable loss ( dB )	TX Antenna Gain ( dBi )	Polarization ( H/V )	Result
3760	-44.85	-13	-31.85	-59.46	-51.48	1.69	8.31	H	Pass
5640	-39.16	-13	-26.16	-58.49	-46.21	2.71	9.76	H	Pass
7520	-53.18	-13	-40.18	-77.88	-62.57	2.42	11.81	H	Pass

<b>Band :</b>	GSM1900		<b>Temperature :</b>	23~24°C					
<b>Test Mode :</b>	GSM Link (GMSK)		<b>Relative Humidity :</b>	46~48%					
<b>Test Engineer :</b>	Derreck Chen		<b>Polarization :</b>	Vertical					
<b>Remark :</b>	Spurious emissions within 30-1000MHz were found more than 20dB below limit line.								
Frequency ( MHz )	EIRP ( dBm )	Limit ( dBm )	Over Limit ( dB )	SPA Reading ( dBm )	S.G. Power ( dBm )	TX Cable loss ( dB )	TX Antenna Gain ( dBi )	Polarization ( H/V )	Result
3760	-45.84	-13	-32.84	-59.99	-52.47	1.69	8.31	V	Pass
5640	-42.91	-13	-29.91	-60.44	-49.96	2.71	9.76	V	Pass
7520	-54.19	-13	-41.19	-77.87	-63.58	2.42	11.81	V	Pass



<High Channel>

<b>Band :</b>	GSM1900				<b>Temperature :</b>	23~24°C			
<b>Test Mode :</b>	GSM Link (GMSK)				<b>Relative Humidity :</b>	46~48%			
<b>Test Engineer :</b>	Derreck Chen				<b>Polarization :</b>	Horizontal			
<b>Remark :</b>	Spurious emissions within 30-1000MHz were found more than 20dB below limit line.								
Frequency ( MHz )	EIRP ( dBm )	Limit ( dBm )	Over Limit ( dB )	SPA Reading ( dBm )	S.G. Power ( dBm )	TX Cable loss ( dB )	TX Antenna Gain ( dBi )	Polarization ( H/V )	Result
3819	-50.91	-13	-37.91	-65.55	-57.59	1.70	8.38	H	Pass
5729	-42.99	-13	-29.99	-62.31	-50.02	2.76	9.79	H	Pass
7639	-52.91	-13	-39.91	-77.15	-62.41	2.38	11.88	H	Pass

<b>Band :</b>	GSM1900				<b>Temperature :</b>	23~24°C			
<b>Test Mode :</b>	GSM Link (GMSK)				<b>Relative Humidity :</b>	46~48%			
<b>Test Engineer :</b>	Derreck Chen				<b>Polarization :</b>	Vertical			
<b>Remark :</b>	Spurious emissions within 30-1000MHz were found more than 20dB below limit line.								
Frequency ( MHz )	EIRP ( dBm )	Limit ( dBm )	Over Limit ( dB )	SPA Reading ( dBm )	S.G. Power ( dBm )	TX Cable loss ( dB )	TX Antenna Gain ( dBi )	Polarization ( H/V )	Result
3819	-51.41	-13	-38.41	-65.27	-58.09	1.70	8.38	V	Pass
5729	-43.09	-13	-30.09	-61.2	-50.12	2.76	9.79	V	Pass
7639	-54.34	-13	-41.34	-77.89	-63.84	2.38	11.88	V	Pass



<Low Channel>

<b>Band :</b>	GSM1900		<b>Temperature :</b>	23~24°C					
<b>Test Mode :</b>	EDGE class 8 Link (8PSK)		<b>Relative Humidity :</b>	46~48%					
<b>Test Engineer :</b>	Derreck Chen		<b>Polarization :</b>	Horizontal					
<b>Remark :</b>	Spurious emissions within 30-1000MHz were found more than 20dB below limit line.								
Frequency ( MHz )	EIRP ( dBm )	Limit ( dBm )	Over Limit ( dB )	SPA Reading ( dBm )	S.G. Power ( dBm )	TX Cable loss ( dB )	TX Antenna Gain ( dBi )	Polarization ( H/V )	Result
3700	-53.55	-13	-40.55	-67.5	-60.12	1.67	8.24	H	Pass
5548	-47.89	-13	-34.89	-67.05	-54.96	2.65	9.72	H	Pass
7403	-52.95	-13	-39.95	-77.88	-62.1	2.46	11.61	H	Pass

<b>Band :</b>	GSM1900		<b>Temperature :</b>	23~24°C					
<b>Test Mode :</b>	EDGE class 8 Link (8PSK)		<b>Relative Humidity :</b>	46~48%					
<b>Test Engineer :</b>	Derreck Chen		<b>Polarization :</b>	Vertical					
<b>Remark :</b>	Spurious emissions within 30-1000MHz were found more than 20dB below limit line.								
Frequency ( MHz )	EIRP ( dBm )	Limit ( dBm )	Over Limit ( dB )	SPA Reading ( dBm )	S.G. Power ( dBm )	TX Cable loss ( dB )	TX Antenna Gain ( dBi )	Polarization ( H/V )	Result
3700	-52.65	-13	-39.65	-66.66	-59.22	1.67	8.24	V	Pass
5548	-48.05	-13	-35.05	-66.52	-55.12	2.65	9.72	V	Pass
7403	-54.12	-13	-41.12	-77.91	-63.27	2.46	11.61	V	Pass



<Middle Channel>

<b>Band :</b>	GSM1900	<b>Temperature :</b>	23~24°C						
<b>Test Mode :</b>	EDGE class 8 Link (8PSK)	<b>Relative Humidity :</b>	46~48%						
<b>Test Engineer :</b>	Derreck Chen	<b>Polarization :</b>	Horizontal						
<b>Remark :</b>	Spurious emissions within 30-1000MHz were found more than 20dB below limit line.								
Frequency ( MHz )	EIRP ( dBm )	Limit ( dBm )	Over Limit ( dB )	SPA Reading ( dBm )	S.G. Power ( dBm )	TX Cable loss ( dB )	TX Antenna Gain ( dBi )	Polarization ( H/V )	Result
3763	-56.66	-13	-43.66	-71.22	-63.29	1.69	8.32	H	Pass
5639	-47.34	-13	-34.34	-66.67	-54.39	2.71	9.76	H	Pass
7520	-53.47	-13	-40.47	-77.95	-62.86	2.42	11.81	H	Pass

<b>Band :</b>	GSM1900	<b>Temperature :</b>	23~24°C						
<b>Test Mode :</b>	EDGE class 8 Link (8PSK)	<b>Relative Humidity :</b>	46~48%						
<b>Test Engineer :</b>	Derreck Chen	<b>Polarization :</b>	Vertical						
<b>Remark :</b>	Spurious emissions within 30-1000MHz were found more than 20dB below limit line.								
Frequency ( MHz )	EIRP ( dBm )	Limit ( dBm )	Over Limit ( dB )	SPA Reading ( dBm )	S.G. Power ( dBm )	TX Cable loss ( dB )	TX Antenna Gain ( dBi )	Polarization ( H/V )	Result
3763	-54.22	-13	-41.22	-68.26	-60.85	1.69	8.32	V	Pass
5639	-49.96	-13	-36.96	-67.85	-57.01	2.71	9.76	V	Pass
7520	-54.56	-13	-41.56	-78.02	-63.95	2.42	11.81	V	Pass



<High Channel>

<b>Band :</b>	GSM1900		<b>Temperature :</b>	23~24°C					
<b>Test Mode :</b>	EDGE class 8 Link (8PSK)		<b>Relative Humidity :</b>	46~48%					
<b>Test Engineer :</b>	Derreck Chen		<b>Polarization :</b>	Horizontal					
<b>Remark :</b>	Spurious emissions within 30-1000MHz were found more than 20dB below limit line.								
Frequency ( MHz )	EIRP ( dBm )	Limit ( dBm )	Over Limit ( dB )	SPA Reading ( dBm )	S.G. Power ( dBm )	TX Cable loss ( dB )	TX Antenna Gain ( dBi )	Polarization ( H/V )	Result
3819	-55.50	-13	-42.50	-70.04	-62.18	1.70	8.38	H	Pass
5729	-48.26	-13	-35.26	-67.67	-55.29	2.76	9.79	H	Pass
7639	-53.08	-13	-40.08	-77.65	-62.58	2.38	11.88	H	Pass

<b>Band :</b>	GSM1900		<b>Temperature :</b>	23~24°C					
<b>Test Mode :</b>	EDGE class 8 Link (8PSK)		<b>Relative Humidity :</b>	46~48%					
<b>Test Engineer :</b>	Derreck Chen		<b>Polarization :</b>	Vertical					
<b>Remark :</b>	Spurious emissions within 30-1000MHz were found more than 20dB below limit line.								
Frequency ( MHz )	EIRP ( dBm )	Limit ( dBm )	Over Limit ( dB )	SPA Reading ( dBm )	S.G. Power ( dBm )	TX Cable loss ( dB )	TX Antenna Gain ( dBi )	Polarization ( H/V )	Result
3819	-56.90	-13	-43.90	-70.79	-63.58	1.70	8.38	V	Pass
5729	-50.21	-13	-37.21	-68.77	-57.24	2.76	9.79	V	Pass
7639	-54.19	-13	-41.19	-77.85	-63.69	2.38	11.88	V	Pass



<Low Channel>

<b>Band :</b>	WCDMA Band V	<b>Temperature :</b>	23~24°C						
<b>Test Mode :</b>	RMC 12.2Kbps Link (QPSK)	<b>Relative Humidity :</b>	46~48%						
<b>Test Engineer :</b>	Derreck Chen	<b>Polarization :</b>	Horizontal						
<b>Remark :</b>	Spurious emissions within 30-1000MHz were found more than 20dB below limit line.								
Frequency ( MHz )	ERP ( dBm )	Limit ( dBm )	Over Limit ( dB )	SPA Reading ( dBm )	S.G. Power ( dBm )	TX Cable loss ( dB )	TX Antenna Gain ( dBi )	Polarization ( H/V )	Result
1652	-65.83	-13	-52.83	-70.05	-67.57	0.98	4.87	H	Pass
2479	-65.09	-13	-52.09	-74.37	-66.99	1.28	5.34	H	Pass
3304	-61.84	-13	-48.84	-74.12	-65.28	1.54	7.14	H	Pass

<b>Band :</b>	WCDMA Band V	<b>Temperature :</b>	23~24°C						
<b>Test Mode :</b>	RMC 12.2Kbps Link (QPSK)	<b>Relative Humidity :</b>	46~48%						
<b>Test Engineer :</b>	Derreck Chen	<b>Polarization :</b>	Vertical						
<b>Remark :</b>	Spurious emissions within 30-1000MHz were found more than 20dB below limit line.								
Frequency ( MHz )	ERP ( dBm )	Limit ( dBm )	Over Limit ( dB )	SPA Reading ( dBm )	S.G. Power ( dBm )	TX Cable loss ( dB )	TX Antenna Gain ( dBi )	Polarization ( H/V )	Result
1652	-68.78	-13	-55.78	-71.37	-70.52	0.98	4.87	V	Pass
2479	-64.69	-13	-51.69	-75.06	-66.59	1.28	5.34	V	Pass
3304	-64.05	-13	-51.05	-75.29	-67.49	1.54	7.14	V	Pass



<Middle Channel>

<b>Band :</b>	WCDMA Band V	<b>Temperature :</b>	23~24°C						
<b>Test Mode :</b>	RMC 12.2Kbps Link (QPSK)	<b>Relative Humidity :</b>	46~48%						
<b>Test Engineer :</b>	Derreck Chen	<b>Polarization :</b>	Horizontal						
<b>Remark :</b>	Spurious emissions within 30-1000MHz were found more than 20dB below limit line.								
Frequency ( MHz )	ERP ( dBm )	Limit ( dBm )	Over Limit ( dB )	SPA Reading ( dBm )	S.G. Power ( dBm )	TX Cable loss ( dB )	TX Antenna Gain ( dBi )	Polarization ( H/V )	Result
1672	-64.71	-13	-51.71	-68.88	-66.39	0.99	4.82	H	Pass
2509	-64.87	-13	-51.87	-74.03	-66.83	1.29	5.41	H	Pass
3345	-60.98	-13	-47.98	-72.92	-64.59	1.56	7.32	H	Pass

<b>Band :</b>	WCDMA Band V	<b>Temperature :</b>	23~24°C						
<b>Test Mode :</b>	RMC 12.2Kbps Link (QPSK)	<b>Relative Humidity :</b>	46~48%						
<b>Test Engineer :</b>	Derreck Chen	<b>Polarization :</b>	Vertical						
<b>Remark :</b>	Spurious emissions within 30-1000MHz were found more than 20dB below limit line.								
Frequency ( MHz )	ERP ( dBm )	Limit ( dBm )	Over Limit ( dB )	SPA Reading ( dBm )	S.G. Power ( dBm )	TX Cable loss ( dB )	TX Antenna Gain ( dBi )	Polarization ( H/V )	Result
1672	-69.89	-13	-56.89	-72.85	-71.57	0.99	4.82	V	Pass
2509	-65.00	-13	-52.00	-74.88	-66.96	1.29	5.41	V	Pass
3345	-62.21	-13	-49.21	-73.26	-65.82	1.56	7.32	V	Pass



<High Channel>

<b>Band :</b>	WCDMA Band V	<b>Temperature :</b>	23~24°C						
<b>Test Mode :</b>	RMC 12.2Kbps Link (QPSK)	<b>Relative Humidity :</b>	46~48%						
<b>Test Engineer :</b>	Derreck Chen	<b>Polarization :</b>	Horizontal						
<b>Remark :</b>	Spurious emissions within 30-1000MHz were found more than 20dB below limit line.								
Frequency ( MHz )	ERP ( dBm )	Limit ( dBm )	Over Limit ( dB )	SPA Reading ( dBm )	S.G. Power ( dBm )	TX Cable loss ( dB )	TX Antenna Gain ( dBi )	Polarization ( H/V )	Result
1693	-64.78	-13	-51.78	-69.07	-66.39	1.00	4.76	H	Pass
2539	-65.54	-13	-52.54	-75.23	-67.52	1.30	5.43	H	Pass
3386	-63.41	-13	-50.41	-75.59	-67.19	1.57	7.50	H	Pass

<b>Band :</b>	WCDMA Band V	<b>Temperature :</b>	23~24°C						
<b>Test Mode :</b>	RMC 12.2Kbps Link (QPSK)	<b>Relative Humidity :</b>	46~48%						
<b>Test Engineer :</b>	Derreck Chen	<b>Polarization :</b>	Vertical						
<b>Remark :</b>	Spurious emissions within 30-1000MHz were found more than 20dB below limit line.								
Frequency ( MHz )	ERP ( dBm )	Limit ( dBm )	Over Limit ( dB )	SPA Reading ( dBm )	S.G. Power ( dBm )	TX Cable loss ( dB )	TX Antenna Gain ( dBi )	Polarization ( H/V )	Result
1693	-66.60	-13	-53.60	-70.31	-68.21	1.00	4.76	V	Pass
2539	-64.97	-13	-51.97	-74.7	-66.95	1.30	5.43	V	Pass
3386	-63.70	-13	-50.70	-75.12	-67.48	1.57	7.50	V	Pass



<Low Channel>

<b>Band :</b>	WCDMA Band IV	<b>Temperature :</b>	23~24°C						
<b>Test Mode :</b>	RMC 12.2Kbps Link (QPSK)	<b>Relative Humidity :</b>	46~48%						
<b>Test Engineer :</b>	Derreck Chen	<b>Polarization :</b>	Horizontal						
<b>Remark :</b>	Spurious emissions within 30-1000MHz were found more than 20dB below limit line.								
Frequency ( MHz )	EIRP ( dBm )	Limit ( dBm )	Over Limit ( dB )	SPA Reading ( dBm )	S.G. Power ( dBm )	TX Cable loss ( dB )	TX Antenna Gain ( dBi )	Polarization ( H/V )	Result
3427	-59.23	-13	-46.23	-70.88	-65.33	1.58	7.68	H	Pass
5142	-50.84	-13	-37.84	-69.27	-58.12	2.42	9.70	H	Pass
6849	-54.46	-13	-41.46	-78.04	-62.44	2.64	10.62	H	Pass

<b>Band :</b>	WCDMA Band IV	<b>Temperature :</b>	23~24°C						
<b>Test Mode :</b>	RMC 12.2Kbps Link (QPSK)	<b>Relative Humidity :</b>	46~48%						
<b>Test Engineer :</b>	Derreck Chen	<b>Polarization :</b>	Vertical						
<b>Remark :</b>	Spurious emissions within 30-1000MHz were found more than 20dB below limit line.								
Frequency ( MHz )	EIRP ( dBm )	Limit ( dBm )	Over Limit ( dB )	SPA Reading ( dBm )	S.G. Power ( dBm )	TX Cable loss ( dB )	TX Antenna Gain ( dBi )	Polarization ( H/V )	Result
3427	-54.76	-13	-41.76	-66.71	-60.86	1.58	7.68	V	Pass
5142	-54.70	-13	-41.70	-72.04	-61.98	2.42	9.70	V	Pass
6849	-53.49	-13	-40.49	-78.04	-61.47	2.64	10.62	V	Pass



<Middle Channel>

<b>Band :</b>	WCDMA Band IV	<b>Temperature :</b>	23~24°C						
<b>Test Mode :</b>	RMC 12.2Kbps Link (QPSK)	<b>Relative Humidity :</b>	46~48%						
<b>Test Engineer :</b>	Derreck Chen	<b>Polarization :</b>	Horizontal						
<b>Remark :</b>	Spurious emissions within 30-1000MHz were found more than 20dB below limit line.								
Frequency ( MHz )	EIRP ( dBm )	Limit ( dBm )	Over Limit ( dB )	SPA Reading ( dBm )	S.G. Power ( dBm )	TX Cable loss ( dB )	TX Antenna Gain ( dBi )	Polarization ( H/V )	Result
3469	-58.28	-13	-45.28	-70.84	-64.55	1.59	7.86	H	Pass
5198	-49.14	-13	-36.14	-68.13	-56.39	2.45	9.70	H	Pass
6927	-55.79	-13	-42.79	-78.49	-63.89	2.61	10.71	H	Pass

<b>Band :</b>	WCDMA Band IV	<b>Temperature :</b>	23~24°C						
<b>Test Mode :</b>	RMC 12.2Kbps Link (QPSK)	<b>Relative Humidity :</b>	46~48%						
<b>Test Engineer :</b>	Derreck Chen	<b>Polarization :</b>	Vertical						
<b>Remark :</b>	Spurious emissions within 30-1000MHz were found more than 20dB below limit line.								
Frequency ( MHz )	EIRP ( dBm )	Limit ( dBm )	Over Limit ( dB )	SPA Reading ( dBm )	S.G. Power ( dBm )	TX Cable loss ( dB )	TX Antenna Gain ( dBi )	Polarization ( H/V )	Result
3469	-53.85	-13	-40.85	-66.36	-60.12	1.59	7.86	V	Pass
5198	-53.03	-13	-40.03	-70.79	-60.28	2.45	9.70	V	Pass
6927	-55.88	-13	-42.88	-78.45	-63.98	2.61	10.71	V	Pass



<High Channel>

<b>Band :</b>	WCDMA Band IV				<b>Temperature :</b>	23~24°C			
<b>Test Mode :</b>	RMC 12.2Kbps Link (QPSK)				<b>Relative Humidity :</b>	46~48%			
<b>Test Engineer :</b>	Derreck Chen				<b>Polarization :</b>	Horizontal			
<b>Remark :</b>	Spurious emissions within 30-1000MHz were found more than 20dB below limit line.								
Frequency ( MHz )	EIRP ( dBm )	Limit ( dBm )	Over Limit ( dB )	SPA Reading ( dBm )	S.G. Power ( dBm )	TX Cable loss ( dB )	TX Antenna Gain ( dBi )	Polarization ( H/V )	Result
3504	-59.88	-13	-46.88	-72.72	-66.28	1.61	8.00	H	Pass
5254	-54.99	-13	-41.99	-73.22	-62.21	2.48	9.70	H	Pass
7010	-55.29	-13	-42.29	-78.34	-63.52	2.59	10.82	H	Pass

<b>Band :</b>	WCDMA Band IV				<b>Temperature :</b>	23~24°C			
<b>Test Mode :</b>	RMC 12.2Kbps Link (QPSK)				<b>Relative Humidity :</b>	46~48%			
<b>Test Engineer :</b>	Derreck Chen				<b>Polarization :</b>	Vertical			
<b>Remark :</b>	Spurious emissions within 30-1000MHz were found more than 20dB below limit line.								
Frequency ( MHz )	EIRP ( dBm )	Limit ( dBm )	Over Limit ( dB )	SPA Reading ( dBm )	S.G. Power ( dBm )	TX Cable loss ( dB )	TX Antenna Gain ( dBi )	Polarization ( H/V )	Result
3504	-58.68	-13	-45.68	-72.12	-65.08	1.61	8.00	V	Pass
5254	-57.17	-13	-44.17	-75.38	-64.39	2.48	9.70	V	Pass
7010	-55.35	-13	-42.35	-77.95	-63.58	2.59	10.82	V	Pass



<Low Channel>

<b>Band :</b>	WCDMA Band II	<b>Temperature :</b>	23~24°C						
<b>Test Mode :</b>	RMC 12.2Kbps Link (QPSK)	<b>Relative Humidity :</b>	46~48%						
<b>Test Engineer :</b>	Derreck Chen	<b>Polarization :</b>	Horizontal						
<b>Remark :</b>	Spurious emissions within 30-1000MHz were found more than 20dB below limit line.								
Frequency ( MHz )	EIRP ( dBm )	Limit ( dBm )	Over Limit ( dB )	SPA Reading ( dBm )	S.G. Power ( dBm )	TX Cable loss ( dB )	TX Antenna Gain ( dBi )	Polarization ( H/V )	Result
3707	-51.01	-13	-38.01	-65.28	-57.59	1.67	8.25	H	Pass
5562	-49.33	-13	-36.33	-68.83	-56.39	2.66	9.72	H	Pass
7409	-53.31	-13	-40.31	-78.04	-62.47	2.46	11.62	H	Pass

<b>Band :</b>	WCDMA Band II	<b>Temperature :</b>	23~24°C						
<b>Test Mode :</b>	RMC 12.2Kbps Link (QPSK)	<b>Relative Humidity :</b>	46~48%						
<b>Test Engineer :</b>	Derreck Chen	<b>Polarization :</b>	Vertical						
<b>Remark :</b>	Spurious emissions within 30-1000MHz were found more than 20dB below limit line.								
Frequency ( MHz )	EIRP ( dBm )	Limit ( dBm )	Over Limit ( dB )	SPA Reading ( dBm )	S.G. Power ( dBm )	TX Cable loss ( dB )	TX Antenna Gain ( dBi )	Polarization ( H/V )	Result
3707	-50.32	-13	-37.32	-64.3	-56.9	1.67	8.25	V	Pass
5562	-51.95	-13	-38.95	-69.72	-59.01	2.66	9.72	V	Pass
7409	-54.11	-13	-41.11	-77.87	-63.27	2.46	11.62	V	Pass



<Middle Channel>

<b>Band :</b>	WCDMA Band II	<b>Temperature :</b>	23~24°C						
<b>Test Mode :</b>	RMC 12.2Kbps Link (QPSK)	<b>Relative Humidity :</b>	46~48%						
<b>Test Engineer :</b>	Derreck Chen	<b>Polarization :</b>	Horizontal						
<b>Remark :</b>	Spurious emissions within 30-1000MHz were found more than 20dB below limit line.								
Frequency ( MHz )	EIRP ( dBm )	Limit ( dBm )	Over Limit ( dB )	SPA Reading ( dBm )	S.G. Power ( dBm )	TX Cable loss ( dB )	TX Antenna Gain ( dBi )	Polarization ( H/V )	Result
3763	-56.65	-13	-43.65	-70.95	-63.28	1.69	8.32	H	Pass
5639	-51.97	-13	-38.97	-70.92	-59.02	2.71	9.76	H	Pass
7520	-53.82	-13	-40.82	-78.01	-63.21	2.42	11.81	H	Pass

<b>Band :</b>	WCDMA Band II	<b>Temperature :</b>	23~24°C						
<b>Test Mode :</b>	RMC 12.2Kbps Link (QPSK)	<b>Relative Humidity :</b>	46~48%						
<b>Test Engineer :</b>	Derreck Chen	<b>Polarization :</b>	Vertical						
<b>Remark :</b>	Spurious emissions within 30-1000MHz were found more than 20dB below limit line.								
Frequency ( MHz )	EIRP ( dBm )	Limit ( dBm )	Over Limit ( dB )	SPA Reading ( dBm )	S.G. Power ( dBm )	TX Cable loss ( dB )	TX Antenna Gain ( dBi )	Polarization ( H/V )	Result
3763	-55.58	-13	-42.58	-69.6	-62.21	1.69	8.32	V	Pass
5639	-54.42	-13	-41.42	-72.04	-61.47	2.71	9.76	V	Pass
7520	-54.93	-13	-41.93	-78.13	-64.32	2.42	11.81	V	Pass



<High Channel>

<b>Band :</b>	WCDMA Band II	<b>Temperature :</b>	23~24°C						
<b>Test Mode :</b>	RMC 12.2Kbps Link (QPSK)	<b>Relative Humidity :</b>	46~48%						
<b>Test Engineer :</b>	Derreck Chen	<b>Polarization :</b>	Horizontal						
<b>Remark :</b>	Spurious emissions within 30-1000MHz were found more than 20dB below limit line.								
Frequency ( MHz )	EIRP ( dBm )	Limit ( dBm )	Over Limit ( dB )	SPA Reading ( dBm )	S.G. Power ( dBm )	TX Cable loss ( dB )	TX Antenna Gain ( dBi )	Polarization ( H/V )	Result
3819	-55.80	-13	-42.80	-70.47	-62.48	1.70	8.38	H	Pass
5723	-52.65	-13	-39.65	-72.14	-59.69	2.75	9.79	H	Pass
7630	-53.79	-13	-40.79	-77.94	-63.28	2.39	11.88	H	Pass

<b>Band :</b>	WCDMA Band II	<b>Temperature :</b>	23~24°C						
<b>Test Mode :</b>	RMC 12.2Kbps Link (QPSK)	<b>Relative Humidity :</b>	46~48%						
<b>Test Engineer :</b>	Derreck Chen	<b>Polarization :</b>	Vertical						
<b>Remark :</b>	Spurious emissions within 30-1000MHz were found more than 20dB below limit line.								
Frequency ( MHz )	EIRP ( dBm )	Limit ( dBm )	Over Limit ( dB )	SPA Reading ( dBm )	S.G. Power ( dBm )	TX Cable loss ( dB )	TX Antenna Gain ( dBi )	Polarization ( H/V )	Result
3819	-56.76	-13	-43.76	-70.16	-63.44	1.70	8.38	V	Pass
5723	-54.04	-13	-41.04	-72.31	-61.08	2.75	9.79	V	Pass
7630	-53.98	-13	-40.98	-77.6	-63.47	2.39	11.88	V	Pass



### 3.8 Frequency Stability Measurement

#### 3.8.1 Description of Frequency Stability Measurement

The frequency stability shall be measured by variation of ambient temperature and variation of primary supply voltage to ensure that the fundamental emission stays within the authorized frequency block. The frequency stability of the transmitter shall be maintained within  $\pm 0.00025\%$  ( $\pm 2.5\text{ppm}$ ) of the center frequency.

#### 3.8.2 Measuring Instruments

The measuring equipment is listed in the section 4 of this test report.

#### 3.8.3 Test Procedures for Temperature Variation

1. The testing follows FCC KDB 971168 v02r02 Section 9.0.
2. The EUT was set up in the thermal chamber and connected with the system simulator.
3. With power OFF, the temperature was decreased to  $-30^{\circ}\text{C}$  and the EUT was stabilized before testing. Power was applied and the maximum change in frequency was recorded within one minute.
4. With power OFF, the temperature was raised in  $10^{\circ}\text{C}$  steps up to  $50^{\circ}\text{C}$ . The EUT was stabilized at each step for at least half an hour. Power was applied and the maximum frequency change was recorded within one minute.

#### 3.8.4 Test Procedures for Voltage Variation

1. The testing follows FCC KDB 971168 v02r02 Section 9.0.
2. The EUT was placed in a temperature chamber at  $25\pm 5^{\circ}\text{C}$  and connected with the system simulator.
3. The power supply voltage to the EUT was varied from BEP to 115% of the nominal value measured at the input to the EUT.
4. The variation in frequency was measured for the worst case.

### 3.8.5 Test Setup

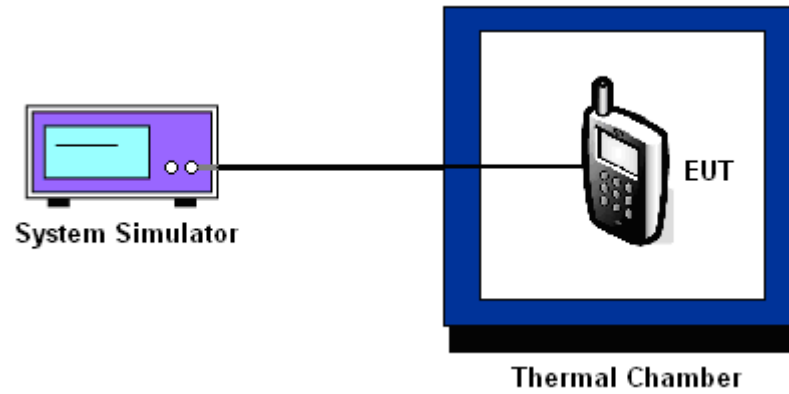



3.8.6 Test Result of Temperature Variation

Band :	GSM 850	Channel :	189
Limit (ppm) :	2.5	Frequency :	836.4 MHz

Temperature (°C)	GSM		EDGE class 8		Result
	Freq. Dev. (Hz)	Deviation (ppm)	Freq. Dev. (Hz)	Deviation (ppm)	
50	-27	0.0323	-2	0.0024	PASS
40	4	0.0048	-3	0.0036	
30	2	0.0024	0	0.0000	
20(Ref.)	0	0.0000	0	0.0000	
10	-2	0.0024	2	0.0024	
0	3	0.0036	3	0.0036	
-10	1	0.0012	2	0.0024	
-20	-26	0.0311	-2	0.0024	
-30	2	0.0024	-3	0.0036	

Band :	GSM 1900	Channel :	661
Limit (ppm) :	within authorized band	Frequency :	1880.0 MHz

Temperature (°C)	GSM		EDGE class 8		Result
	Freq. Dev. (Hz)	Deviation (ppm)	Freq. Dev. (Hz)	Deviation (ppm)	
50	9	0.0048	-3	0.0016	PASS
40	-5	0.0027	5	0.0027	
30	-3	0.0016	0	0.0000	
20(Ref.)	0	0.0000	0	0.0000	
10	-1	0.0005	2	0.0011	
0	4	0.0021	4	0.0021	
-10	51	0.0271	9	0.0048	
-20	5	0.0027	9	0.0048	
-30	0	0.0000	6	0.0032	

Note: The frequency fundamental emissions stay within the authorized frequency block based on the frequency deviation measured is small.



<b>Band :</b>	WCDMA Band V	<b>Channel :</b>	4182
<b>Limit (ppm) :</b>	2.5	<b>Frequency :</b>	836.4 MHz

Temperature (°C)	RMC 12.2Kbps		Result
	Freq. Dev. (Hz)	Deviation (ppm)	
50	15	0.0179	PASS
40	3	0.0036	
30	1	0.0012	
20(Ref.)	0	0.0000	
10	1	0.0012	
0	2	0.0024	
-10	3	0.0036	
-20	1	0.0012	
-30	-2	0.0024	

<b>Band :</b>	WCDMA Band IV	<b>Channel :</b>	1413
<b>Limit (ppm) :</b>	within authorized band	<b>Frequency :</b>	1732.6 MHz

Temperature (°C)	RMC 12.2Kbps		Result
	Freq. Dev. (Hz)	Deviation (ppm)	
50	18	0.0104	PASS
40	15	0.0087	
30	16	0.0092	
20(Ref.)	0	0.0000	
10	-2	0.0012	
0	6	0.0035	
-10	4	0.0023	
-20	6	0.0035	
-30	3	0.0017	

Note: The frequency fundamental emissions stay within the authorized frequency block based on the frequency deviation measured is small.



<b>Band :</b>	WCDMA Band II	<b>Channel :</b>	9400
<b>Limit (ppm) :</b>	within authorized band	<b>Frequency :</b>	1880.0 MHz

Temperature (°C)	RMC 12.2Kbps		Result
	Freq. Dev. (Hz)	Deviation (ppm)	
50	104	0.0553	PASS
40	0	0.0000	
30	-1	0.0005	
20(Ref.)	0	0.0000	
10	0	0.0000	
0	-1	0.0005	
-10	11	0.0059	
-20	-2	0.0011	
-30	0	0.0000	

Note: The frequency fundamental emissions stay within the authorized frequency block based on the frequency deviation measured is small.



3.8.7 Test Result of Voltage Variation

Band & Channel	Mode	Voltage (Volt)	Freq. Dev. (Hz)	Deviation (ppm)	Limit (ppm)	Result
GSM 850 CH189	GSM	4.35	1	0.0012	2.5	PASS
		3.95	-28	0.0335		
		BEP	3	0.0036		
	EDGE class 8	4.35	6	0.0072		
		3.95	2	0.0024		
		BEP	0	0.0000		
GSM 1900 CH661	GSM	4.35	2	0.0011	(Note 3.)	
		3.95	46	0.0245		
		BEP	51	0.0271		
	EDGE class 8	4.35	7	0.0037		
		3.95	9	0.0048		
		BEP	5	0.0027		
WCDMA Band V CH4182	RMC 12.2Kbps	4.35	0	0.0000	2.5	
		3.95	11	0.0132		
		BEP	-1	0.0012		
WCDMA Band IV CH1413	RMC 12.2Kbps	4.35	18	0.0104	(Note 3.)	
		3.95	6	0.0035		
		BEP	20	0.0115		
WCDMA Band II CH9400	RMC 12.2Kbps	4.35	-2	0.0011	(Note 3.)	
		3.95	-2	0.0011		
		BEP	12	0.0064		

Note:

1. Normal Voltage = 3.95V.
2. Battery End Point (BEP) = 3.55 V.
3. The frequency fundamental emissions stay within the authorized frequency block based on the frequency deviation measured is small.



## 4 List of Measuring Equipment

Instrument	Manufacturer	Model No.	Serial No.	Characteristics	Calibration Date	Test Date	Due Date	Remark
Signal Generator	Rohde & Schwarz	SMU200A	102502	9kHz~6GHz	Jul. 07, 2014	May 08, 2015~ May 11, 2015	Jul. 06, 2015	Conducted (TH02-HY)
System Simulator	Rohde & Schwarz	CMU200	117995	N/A	Jul. 29, 2014	May 08, 2015~ May 11, 2015	Jul. 28, 2015	Conducted (TH02-HY)
Thermal Chamber	Ten Billion	TTH-D3SP	TBN-930701	N/A	Jul. 17, 2014	May 08, 2015~ May 11, 2015	Jul. 16, 2015	Conducted (TH02-HY)
Amplifier	SONOMA	310N	187312	9kHz~1GHz	Nov. 24, 2014	Apr. 28, 2015~ May 12,2015	Nov. 23, 2015	Radiation (03CH11-HY)
Bilog Antenna	TESEQ	CBL 6111D	35414	30MHz~1GHz	Oct. 24, 2014	Apr. 28, 2015~ May 12,2015	Oct. 23, 2015	Radiation (03CH11-HY)
Horn Antenna	SCHWARZBEC K	BBHA 9120 D	9120D-1326	1GHz ~ 18GHz	Oct. 03, 2014	Apr. 28, 2015~ May 12,2015	Oct. 02, 2015	Radiation (03CH11-HY)
Horn Antenna	SCHWARZBEC K	BBHA 9120 D	9120D-1328	1GHz ~ 18GHz	Nov. 05, 2014	Apr. 28, 2015~ May 12,2015	Nov. 04, 2015	Radiation (03CH11-HY)
Preamplifier	Keysight	83017A	MY53270080	1GHz~26.5GHz	Nov. 20, 2014	Apr. 28, 2015~ May 12,2015	Nov. 19, 2015	Radiation (03CH11-HY)
Amplifier	SONOMA	310N	187312	9kHz~1GHz	Nov. 24, 2014	Apr. 28, 2015~ May 12,2015	Nov. 23, 2015	Radiation (03CH11-HY)
Spectrum Analyzer	Keysight	N9010A	MY54200486	10Hz ~ 44GHZ	Sep. 24, 2014	Apr. 28, 2015~ May 12,2015	Sep. 23, 2015	Radiation (03CH11-HY)
Antenna Mast	EMEC	AM-BS-4500- B	N/A	1~4m	N/A	Apr. 28, 2015~ May 12,2015	N/A	Radiation (03CH11-HY)
Turn Table	EMEC	TT 2000	N/A	0-360 degree	N/A	Apr. 28, 2015~ May 12,2015	N/A	Radiation (03CH11-HY)
Signal Generator	Rohde & Schwarz	SMF100A	101107	100kHz~40GHz	May 23, 2014	Apr. 28, 2015~ May 12,2015	May 22, 2015	Radiation (03CH11-HY)
SHF-EHF Horn Antenna	SCHWARZBEC K	BBHA 9170	BBHA91702 51	18GHz~40GHz	Oct. 02, 2014	Apr. 28, 2015~ May 12,2015	Oct. 01, 2015	Radiation (03CH11-HY)



## 5 Uncertainty of Evaluation

### Uncertainty of Radiated Emission Measurement (30 MHz ~ 1000 MHz)

Measuring Uncertainty for a Level of Confidence of 95% ( $U = 2Uc(y)$ )	4.90
---	------