



FCC Test Report

APPLICANT : Motorola Mobility, LLC
EQUIPMENT : Mobile Cellular Phone
BRAND NAME : Motorola Mobility, LLC
MODEL NAME : 4008
FCC ID : IHDT56PG4
STANDARD : FCC 47 CFR FCC Part 15 Subpart B
CLASSIFICATION : Certification

The product was received on Mar. 31, 2014 and testing was completed on May 21, 2014. We, SPORTON INTERNATIONAL INC., would like to declare that the tested sample has been evaluated in accordance with the procedures given in ANSI C63.4-2009 and shown to be compliant with the applicable technical standards.

The test results in this report apply exclusively to the tested model / sample. Without written approval of SPORTON INTERNATIONAL INC., the test report shall not be reproduced except in full.

Reviewed by: Louis Wu / Manager

Approved by: Jones Tsai / Manager



SPORTON INTERNATIONAL INC.

No. 52, Hwa Ya 1st Rd., Hwa Ya Technology Park, Kwei-Shan Hsiang, Tao Yuan Hsien, Taiwan, R.O.C.



TABLE OF CONTENTS

REVISION HISTORY.....3

SUMMARY OF TEST RESULT4

1. GENERAL DESCRIPTION5

 1.1. Applicant.....5

 1.2. Manufacturer5

 1.3. Feature of Equipment Under Test.....5

 1.4. Product Specification of Equipment Under Test6

 1.5. Modification of EUT6

 1.6. Test Location.....7

 1.7. Applicable Standards7

2. TEST CONFIGURATION OF EQUIPMENT UNDER TEST8

 2.1. Test Mode8

 2.2. Connection Diagram of Test System 10

 2.3. Support Unit used in test configuration and system..... 11

 2.4. EUT Operation Test Setup 11

3. TEST RESULT 12

 3.1. Test of AC Conducted Emission Measurement 12

 3.2. Test of Radiated Emission Measurement 18

4. LIST OF MEASURING EQUIPMENT 24

5. UNCERTAINTY OF EVALUATION 25



SUMMARY OF TEST RESULT

Report Section	FCC Rule	Description	Limit	Result	Remark
3.1	15.107	AC Conducted Emission	< 15.107 limits	PASS	Under limit 16.60 dB at 0.494 MHz
3.2	15.109	Radiated Emission	< 15.109 limits	PASS	Under limit 15.08 dB at 300.000 MHz



1. General Description

1.1. Applicant

Motorola Mobility, LLC

222 W Merchandise Mart Plaza, Suite 1800, Chicago, IL 60654, United States

1.2. Manufacturer

Motorola Mobility, LLC

222 W Merchandise Mart Plaza, Suite 1800, Chicago, IL 60654, United States

1.3. Feature of Equipment Under Test

Product Feature	
Equipment	Mobile Cellular Phone
Brand Name	Motorola Mobility, LLC
Model Name	4008
FCC ID	IHDT56PG4
IMEI Code	359290050004054
EUT supports Radios application	GSM/EGPRS/WCDMA/HSPA WLAN 11b/g/n(HT20) Bluetooth v4.0 EDR/LE
HW Version	P3A
SW Version	4.4.2 KXB20.82 66
EUT Stage	Identical Prototype

Remark: The above EUT's information was declared by manufacturer. Please refer to the specifications or user's manual for more detailed description.

1.4. Product Specification of Equipment Under Test

Product Specification subjective to this standard	
Tx Frequency	GSM850 : 824.2 MHz ~ 848.8 MHz GSM1900 : 1850.2 MHz ~ 1909.8MHz WCDMA Band V : 826.4 MHz ~ 846.6 MHz WCDMA Band II : 1852.4 MHz ~ 1907.6 MHz 802.11b/g/n: 2412 MHz ~ 2462 MHz Bluetooth: 2402 MHz ~ 2480 MHz
Rx Frequency	GSM850 : 869.2 MHz ~ 893.8 MHz GSM1900 : 1930.2 MHz ~ 1989.8 MHz WCDMA Band V : 871.4 MHz ~ 891.6 MHz WCDMA Band II : 1932.4 MHz ~ 1987.6 MHz 802.11b/g/n: 2412 MHz ~ 2462 MHz Bluetooth: 2402 MHz ~ 2480 MHz GPS : 1.57542 GHz
Antenna Type	WWAN : Fixed Internal Antenna WLAN : PIFA Antenna Bluetooth : PIFA Antenna GPS : Fixed Internal Antenna
Type of Modulation	GSM: GMSK GPRS: GMSK EDGE(MCS 0-4): GMSK / (MCS 5-9): 8PSK WCDMA: QPSK (Uplink) HSDPA: QPSK (Uplink) HSUPA: QPSK (Uplink) 802.11b : DSSS (DBPSK / DQPSK / CCK) 802.11g/n: OFDM (BPSK / QPSK / 16QAM / 64QAM) Bluetooth LE : GFSK Bluetooth (1Mbps) : GFSK Bluetooth (2Mbps) : $\pi/4$ -DQPSK Bluetooth (3Mbps) : 8-DPSK GPS : BPSK

1.5. Modification of EUT

No modifications are made to the EUT during all test items.

1.6. Test Location

Sporton Lab is accredited to ISO 17025 by Taiwan Accreditation Foundation (TAF code : 1190) and the FCC designation No. TW1022 under the FCC 2.948(e) by Mutual Recognition Agreement (MRA) in FCC Test.

Test Site	SPORTON INTERNATIONAL INC.	
Test Site Location	No. 52, Hwa Ya 1 st Rd., Hwa Ya Technology Park, Kwei-Shan Hsiang, Tao Yuan Hsien, Taiwan, R.O.C. TEL: +886-3-327-3456 FAX: +886-3-328-4978	
Test Site No.	Sporton Site No.	
	CO05-HY	03CH06-HY

1.7. Applicable Standards

According to the specifications of the manufacturer, the EUT must comply with the requirements of the following standards:

- ♦ FCC 47 CFR FCC Part 15 Subpart B
- ♦ ANSI C63.4-2009

Remark:

1. All test items were verified and recorded according to the standards and without any deviation during the test.
2. For FCC 15 Subpart B - Unintentional Radiators, device supports FM Radio (Receiver) shall be authorized as "FM broadcast receiver" per the Section 15.101 (a) Equipment authorization of unintentional radiators.
3. For other Unintentional Radiators features of this EUT, test reports are issued separately.
Per the Note of the Section 15.101, when device supports features (USB, FM Radio, digital devices...etc.) more than one category of authorization, type of authorization shall be appropriately chosen for FCC 15B compliance rule, and the Section 15.101 (b), only those receivers that operate (tune) within the frequency range of 30-960 MHz, CB receivers and radar detectors are subject to the authorizations shown in paragraph (a) of the Section 15.101. However, receivers indicated as being subject to Declaration of Conformity that are contained within a transceiver, the transmitter portion of which is subject to certification, shall be authorized under the verification procedure

2. Test Configuration of Equipment Under Test

2.1. Test Mode

The EUT has been associated with peripherals pursuant to ANSI C63.4-2009 and configuration operated in a manner tended to maximize its emission characteristics in a typical application.

Frequency range investigated: conduction (150 kHz to 30 MHz), radiation (30MHz to the 5th harmonic of the highest fundamental frequency or to 40 GHz, whichever is lower).

The following tables are showing the test modes as the worst cases and recorded in this report.

Item	EUT Configuration	Test Condition		
		EMI AC	EMI RE<1G	EMI RE≥1G
1.	Data application transferred mode (EUT with notebook)	☒	☒	☒

Abbreviations:

- EMI AC: AC conducted emissions
- EMI RE ≥ 1G: EUT radiated emissions ≥ 1GHz
- EMI RE < 1G: EUT radiated emissions < 1GHz

Test Items	EUT Configure Mode	Function Type
AC Conducted Emission	1	Mode 1: GSM850 Idle + Bluetooth Idle + WLAN Idle + Earphone + GPS Rx + Battery + USB Cable (Data Link with Notebook) <Fig. 1> Mode 2: WCDMA Band II Idle + Bluetooth Idle + WLAN Idle + Earphone + GPS Rx + Battery + USB Cable (Data Link with Notebook) <Fig. 1> Mode 3: GSM850 Idle + Bluetooth Idle + WLAN Idle + Earphone + GPS Rx + Battery + USB Cable (Data Link with Notebook) + Monitor <Fig. 2>
Radiated Emissions 1GHz	1	Mode 1: GSM850 Idle + Bluetooth Idle + WLAN Idle + Earphone + GPS Rx + Battery + USB Cable (Data Link with Notebook) <Fig. 1> Mode 2: WCDMA Band II Idle + Bluetooth Idle + WLAN Idle + Earphone + GPS Rx + Battery + USB Cable (Data Link with Notebook) <Fig. 1> Mode 3: WCDMA Band II Idle + Bluetooth Idle + WLAN Idle + Earphone + GPS Rx + Battery + USB Cable (Data Link with Notebook) + Monitor <Fig. 2>
Radiated Emissions ≥ 1GHz	1	Mode 1: WCDMA Band II Idle + Bluetooth Idle + WLAN Idle + Earphone + GPS Rx + Battery + USB Cable (Data Link with Notebook) <Fig. 1> Mode 2: WCDMA Band II Idle + Bluetooth Idle + WLAN Idle + Earphone + GPS Rx + Battery + USB Cable (Data Link with Notebook) + Monitor <Fig. 2>

Remark:

1. The worst case of AC is mode 1; the test data of this mode was reported.
2. For AC Conducted Emission, the USB Link mode which Notebook connected with Monitor is mode 3; the test data of this mode was reported.
3. The worst case of RE < 1G is mode 2; the test data of this mode was reported.
4. For Radiated Emissions, the USB Link mode which Notebook connected with Monitor is mode 3; the test data of this mode was reported.
5. Data Link with Notebook means data application transferred mode between EUT and Notebook.

2.2. Connection Diagram of Test System

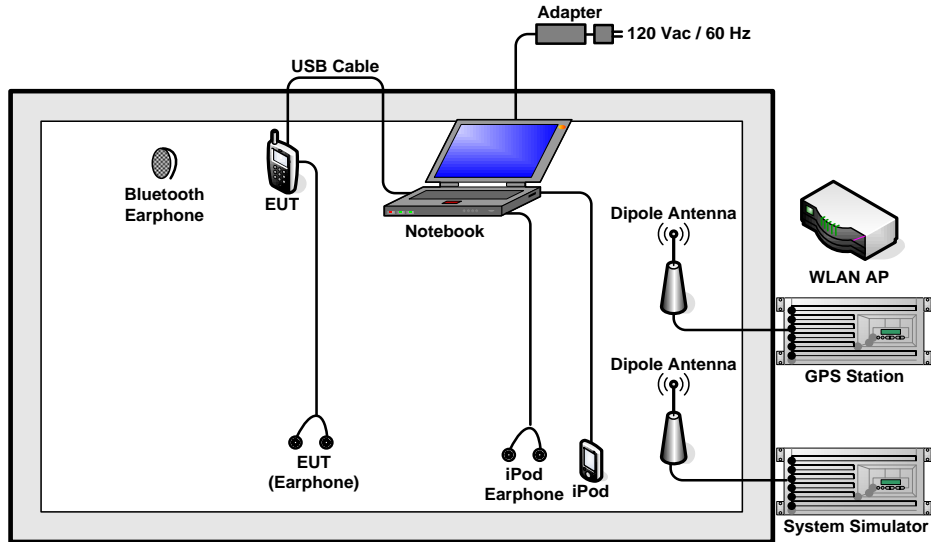

<Fig. 1>

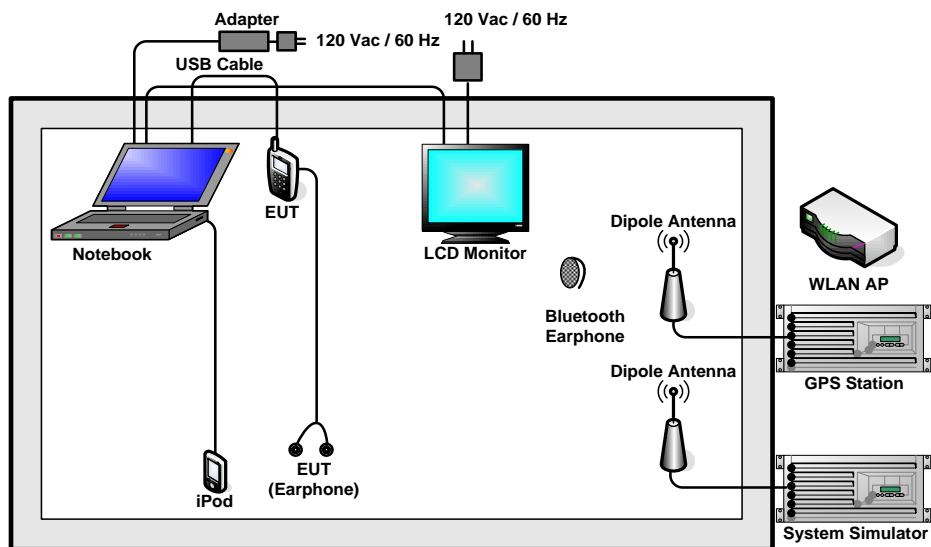

<Fig. 2>

2.3. Support Unit used in test configuration and system

Item	Equipment	Trade Name	Model Name	FCC ID	Data Cable	Power Cord
1.	System Simulator	R&S	CMU 200	N/A	N/A	Unshielded, 1.8 m
2.	GPS Station	Pendulum	GSG-54	N/A	N/A	Unshielded, 1.8 m
3.	WLAN AP	D-Link	DIR-628	KA2DIR628A2	N/A	Unshielded, 1.8 m
4.	Bluetooth Earphone	Sony Ericsson	MW600	PY7DDA-2029	N/A	N/A
5.	Notebook	DELL	Latitude E6320	FCC DoC	N/A	AC I/P: Unshielded, 1.2 m DC O/P: Shielded, 1.8 m
6.	Notebook	DELL	Latitude E7440	FCC DoC	N/A	AC I/P: Unshielded, 1.2 m DC O/P: Shielded, 1.8 m
7.	iPod	Apple	A1285	FCC DoC	Shielded, 1.0 m	N/A
8.	iPod Earphone	Apple	N/A	Verification	Unshielded, 1.0 m	N/A
9.	LCD MONITOR	Dell	U2410	FCC DoC	Shielded, 1.6m	Unshielded,1.8m
10.	SD Card	SanDisk	MicroSD HC	FCC DoC	N/A	N/A

2.4. EUT Operation Test Setup

The EUT was in GSM or WCDMA idle mode during the testing. The EUT was synchronized to the BCCH, and was in continuous receiving mode by setting system simulator's paging reorganization.

At the same time, the EUT was attached to the Bluetooth earphone or WLAN AP, and the following programs installed in the EUT were programmed during the test.

1. Data application is transferred between Laptop and EUT via USB cable.
2. Execute "GPS Test" to make the EUT receive continuous signals from GPS station.

3. Test Result

3.1. Test of AC Conducted Emission Measurement

3.1.1 Limits of AC Conducted Emission

For equipment that is designed to be connected to the public utility (AC) power line, the radio frequency voltage that is conducted back onto the AC power line on any frequency or frequencies within the band 150 kHz to 30 MHz shall not exceed the limits in the following table.

Frequency of emission (MHz)	Conducted limit (dBuV)	
	Quasi-peak	Average
0.15-0.5	66 to 56*	56 to 46*
0.5-5	56	46
5-30	60	50

*Decreases with the logarithm of the frequency.

3.1.2 Measuring Instruments

The measuring equipment is listed in the section 4 of this test report.

3.1.3 Test Procedure

1. The EUT was placed 0.4 meter from the conducting wall of the shielding room was kept at least 80 centimeters from any other grounded conducting surface.
2. Connect EUT to the power mains through a line impedance stabilization network (LISN).
3. All the support units are connecting to the other LISN.
4. The LISN provides 50 ohm coupling impedance for the measuring instrument.
5. The FCC states that a 50 ohm, 50 microhenry LISN should be used.
6. Both sides of AC line were checked for maximum conducted interference.
7. The frequency range from 150 kHz to 30 MHz was searched.
8. Set the test-receiver system to Peak Detect Function and specified bandwidth with Maximum Hold Mode.

3.1.4 Test Setup

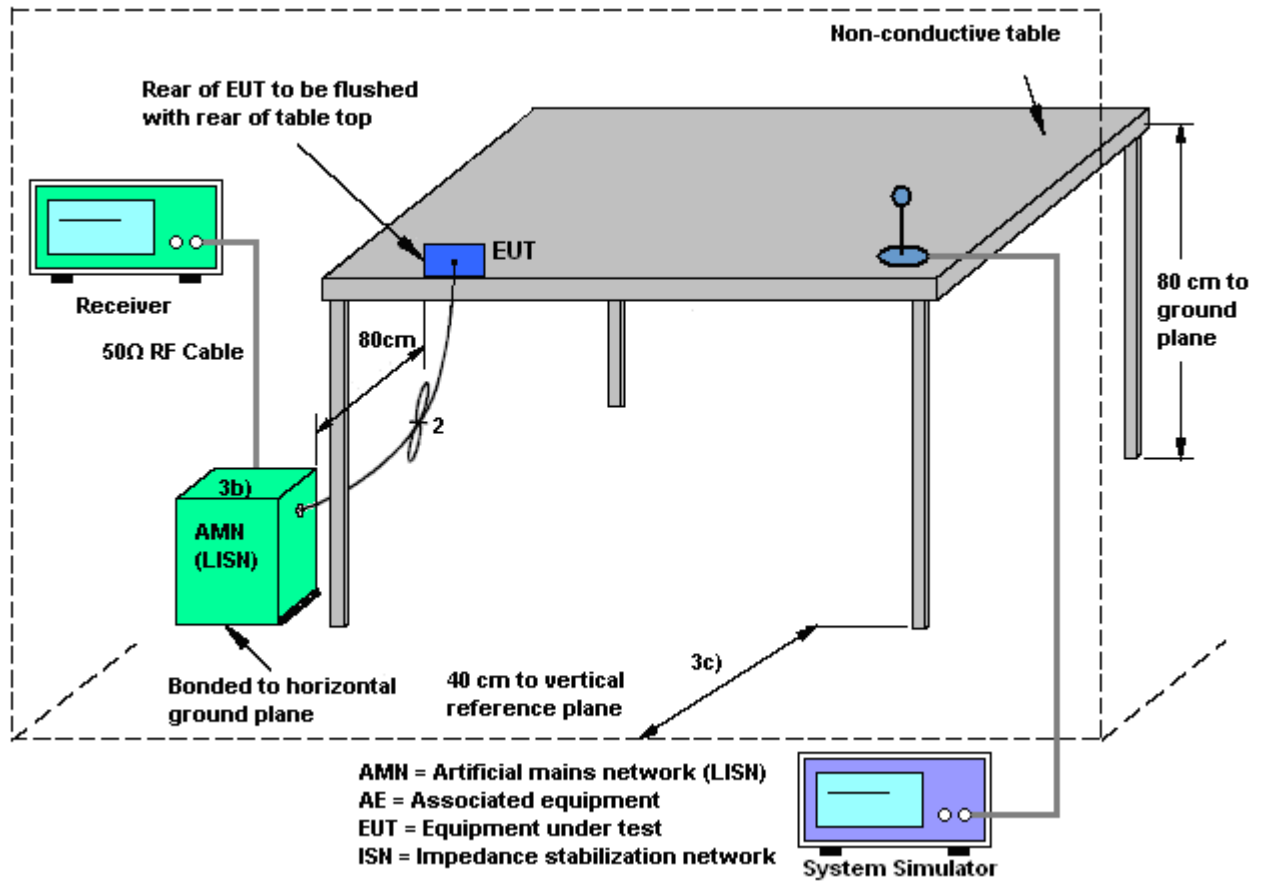

3.1.5 Test Result of AC Conducted Emission

Test Mode :	Mode 1	Temperature :	20~22°C
Test Engineer :	Cosmo Xu	Relative Humidity :	46~48%
Test Voltage :	120Vac / 60Hz	Phase :	Line
Function Type :	GSM850 Idle + Bluetooth Idle + WLAN Idle + Earphone + GPS Rx + Battery + USB Cable (Data Link with Notebook)		

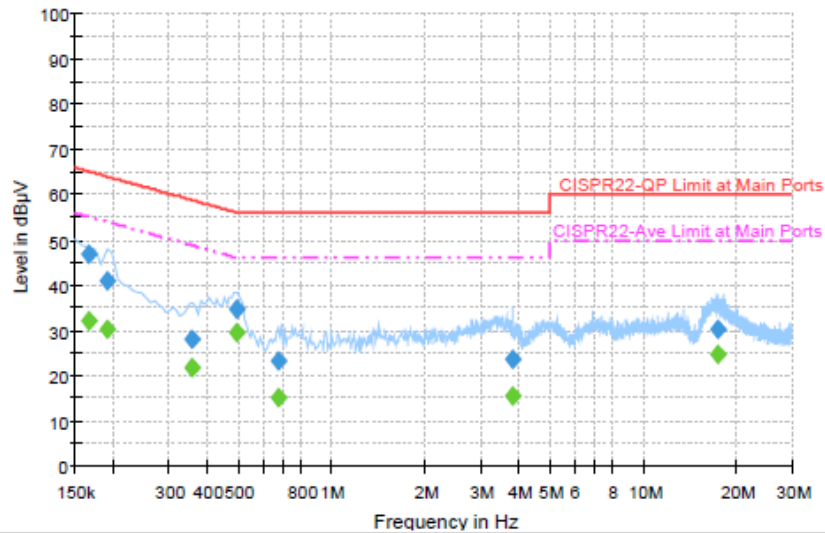

Final Result : Quasi-Peak

Frequency (MHz)	Quasi-Peak (dBµV)	Filter	Line	Corr. (dB)	Margin (dB)	Limit (dBµV)
0.166000	46.9	Off	L1	19.3	18.3	65.2
0.190000	41.1	Off	L1	19.4	22.9	64.0
0.358000	28.2	Off	L1	19.4	30.6	58.8
0.494000	34.7	Off	L1	19.3	21.4	56.1
0.678000	23.1	Off	L1	19.5	32.9	56.0
3.806000	23.6	Off	L1	19.6	32.4	56.0
17.294000	30.1	Off	L1	19.8	29.9	60.0

Final Result : Average

Frequency (MHz)	Average (dBµV)	Filter	Line	Corr. (dB)	Margin (dB)	Limit (dBµV)
0.166000	32.1	Off	L1	19.3	23.1	55.2
0.190000	30.2	Off	L1	19.4	23.8	54.0
0.358000	21.9	Off	L1	19.4	26.9	48.8
0.494000	29.5	Off	L1	19.3	16.6	46.1
0.678000	15.0	Off	L1	19.5	31.0	46.0
3.806000	15.4	Off	L1	19.6	30.6	46.0
17.294000	24.7	Off	L1	19.8	25.3	50.0



Test Mode :	Mode 1	Temperature :	20~22°C
Test Engineer :	Cosmo Xu	Relative Humidity :	46~48%
Test Voltage :	120Vac / 60Hz	Phase :	Neutral
Function Type :	GSM850 Idle + Bluetooth Idle + WLAN Idle + Earphone + GPS Rx + Battery + USB Cable (Data Link with Notebook)		

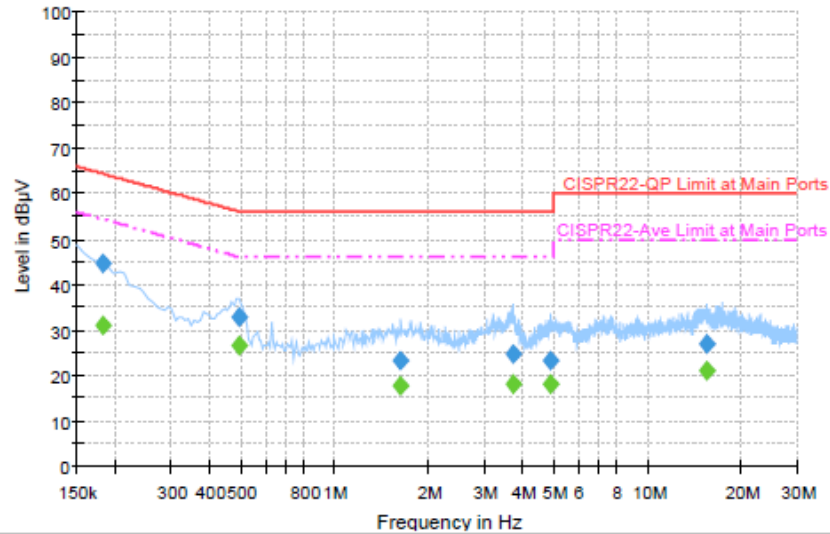

Final Result : Quasi-Peak

Frequency (MHz)	Quasi-Peak (dBµV)	Filter	Line	Corr. (dB)	Margin (dB)	Limit (dBµV)
0.182000	44.6	Off	N	19.3	19.8	64.4
0.494000	32.9	Off	N	19.4	23.2	56.1
1.630000	23.1	Off	N	19.5	32.9	56.0
3.718000	24.8	Off	N	19.7	31.2	56.0
4.926000	23.3	Off	N	19.6	32.7	56.0
15.526000	27.0	Off	N	19.9	33.0	60.0

Final Result : Average

Frequency (MHz)	Average (dBµV)	Filter	Line	Corr. (dB)	Margin (dB)	Limit (dBµV)
0.182000	31.0	Off	N	19.3	23.4	54.4
0.494000	26.4	Off	N	19.4	19.7	46.1
1.630000	17.8	Off	N	19.5	28.2	46.0
3.718000	17.9	Off	N	19.7	28.1	46.0
4.926000	18.0	Off	N	19.6	28.0	46.0
15.526000	21.2	Off	N	19.9	28.8	50.0



Test Mode :	Mode 3	Temperature :	20~22°C
Test Engineer :	Cosmo Xu	Relative Humidity :	46~48%
Test Voltage :	120Vac / 60Hz	Phase :	Line
Function Type :	GSM850 Idle + Bluetooth Idle + WLAN Idle + Earphone + GPS Rx + Battery + USB Cable (Data Link with Notebook) + Monitor		

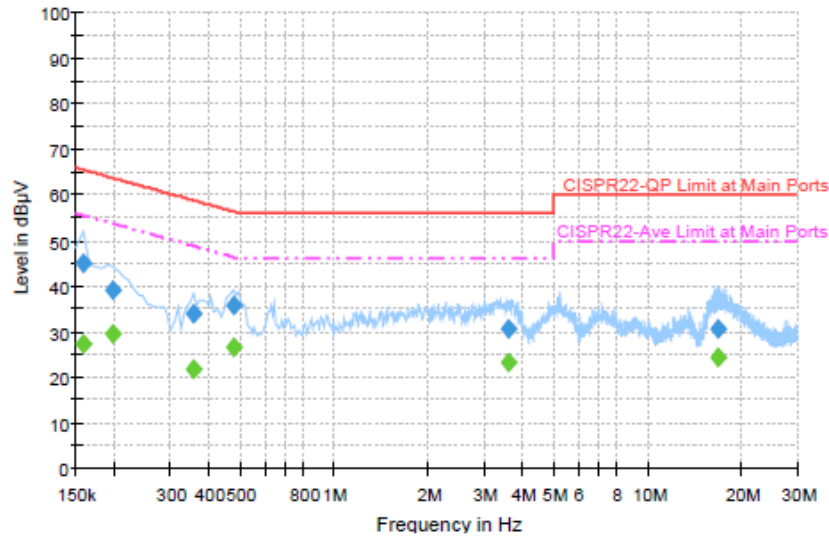

Final Result : Quasi-Peak

Frequency (MHz)	Quasi-Peak (dBµV)	Filter	Line	Corr. (dB)	Margin (dB)	Limit (dBµV)
0.158000	45.2	Off	L1	19.3	20.4	65.6
0.198000	39.3	Off	L1	19.3	24.4	63.7
0.358000	34.0	Off	L1	19.4	24.8	58.8
0.478000	35.7	Off	L1	19.4	20.7	56.4
3.598000	30.7	Off	L1	19.6	25.3	56.0
16.686000	30.8	Off	L1	19.7	29.2	60.0

Final Result : Average

Frequency (MHz)	Average (dBµV)	Filter	Line	Corr. (dB)	Margin (dB)	Limit (dBµV)
0.158000	27.2	Off	L1	19.3	28.4	55.6
0.198000	29.5	Off	L1	19.3	24.2	53.7
0.358000	21.9	Off	L1	19.4	26.9	48.8
0.478000	26.5	Off	L1	19.4	19.9	46.4
3.598000	23.2	Off	L1	19.6	22.8	46.0
16.686000	24.4	Off	L1	19.7	25.6	50.0

Test Mode :	Mode 3	Temperature :	20~22°C
Test Engineer :	Cosmo Xu	Relative Humidity :	46~48%
Test Voltage :	120Vac / 60Hz	Phase :	Neutral
Function Type :	GSM850 Idle + Bluetooth Idle + WLAN Idle + Earphone + GPS Rx + Battery + USB Cable (Data Link with Notebook) + Monitor		

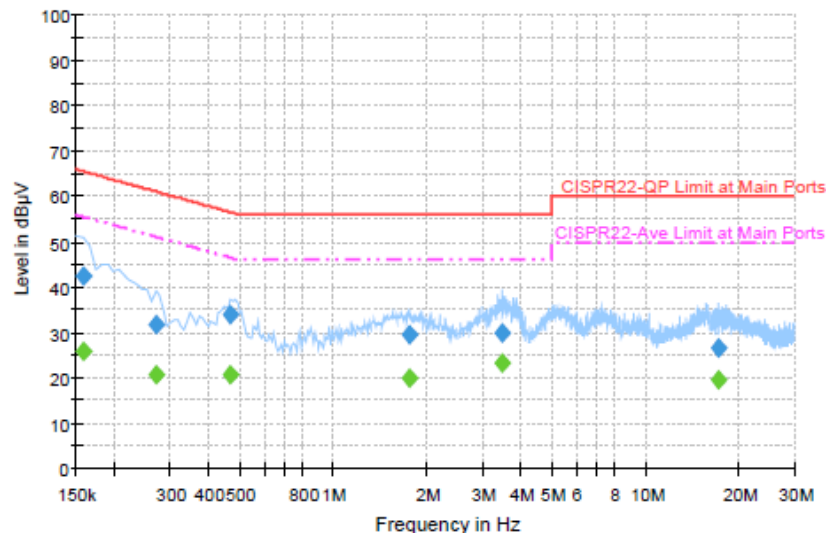

Final Result : Quasi-Peak

Frequency (MHz)	Quasi-Peak (dBµV)	Filter	Line	Corr. (dB)	Margin (dB)	Limit (dBµV)
0.158000	42.5	Off	N	19.3	23.1	65.6
0.270000	31.6	Off	N	19.3	29.5	61.1
0.470000	33.9	Off	N	19.4	22.6	56.5
1.758000	29.6	Off	N	19.5	26.4	56.0
3.478000	30.0	Off	N	19.6	26.0	56.0
17.158000	26.4	Off	N	19.8	33.6	60.0

Final Result : Average

Frequency (MHz)	Average (dBµV)	Filter	Line	Corr. (dB)	Margin (dB)	Limit (dBµV)
0.158000	26.0	Off	N	19.3	29.6	55.6
0.270000	20.8	Off	N	19.3	30.3	51.1
0.470000	20.5	Off	N	19.4	26.0	46.5
1.758000	20.0	Off	N	19.5	26.0	46.0
3.478000	23.1	Off	N	19.6	22.9	46.0
17.158000	19.5	Off	N	19.8	30.5	50.0

3.2. Test of Radiated Emission Measurement

3.2.1. Limit of Radiated Emission

The emissions from an unintentional radiator shall not exceed the field strength levels specified in the following table:

Frequency (MHz)	Field Strength (microvolts/meter)	Measurement Distance (meters)
30 – 88	100	3
88 – 216	150	3
216 - 960	200	3
Above 960	500	3

3.2.2. Measuring Instruments

The measuring equipment is listed in the section 4 of this test report.

3.2.3. Test Procedures

1. The EUT was placed on a turntable with 0.8 meter above ground.
2. The EUT was set 3 meters from the interference receiving antenna, which was mounted on the top of a variable height antenna tower.
3. The table was rotated 360 degrees to determine the position of the highest radiation.
4. The antenna is a Bi-Log antenna and its height is adjusted between one to four meters above ground to find the maximum value of the field strength for both horizontal polarization and vertical polarization of the antenna.
5. For each suspected emission, the EUT was arranged to its worst case and then tune the antenna tower (from 1 m to 4 m) and turntable (from 0 degree to 360 degrees) to find the maximum reading.
6. Set the test-receiver system to Peak Detect Function and specified bandwidth with Maximum Hold Mode.
7. If the emission level of the EUT in peak mode was 3 dB lower than the limit specified, peak values of EUT will be reported. Otherwise, the emission will be repeated by using the quasi-peak method and reported.
8. Emission level (dB μ V/m) = 20 log Emission level (μ V/m)
9. Corrected Reading: Antenna Factor + Cable Loss + Read Level - Preamp Factor = Level

3.2.4. Test Setup of Radiated Emission

For radiated emissions from 30MHz to 1GHz

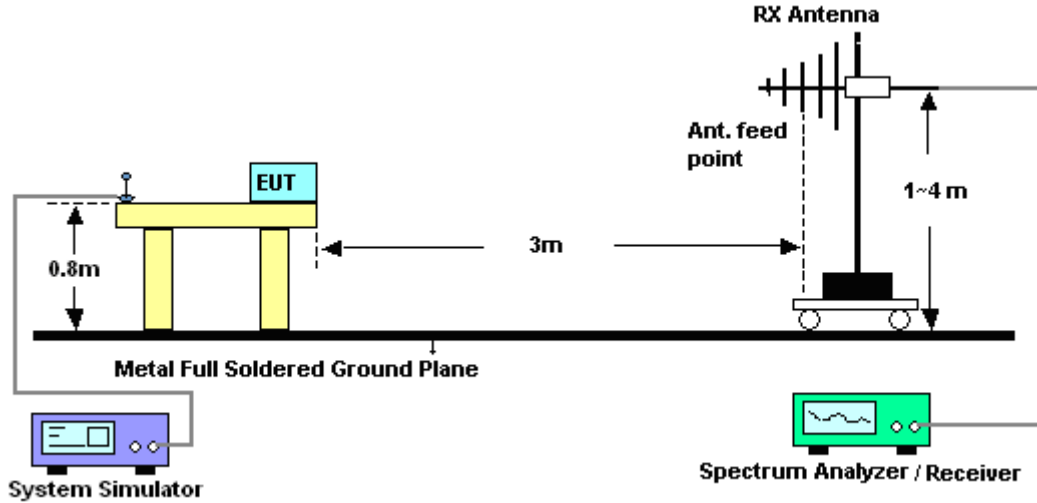

For radiated emissions above 1GHz

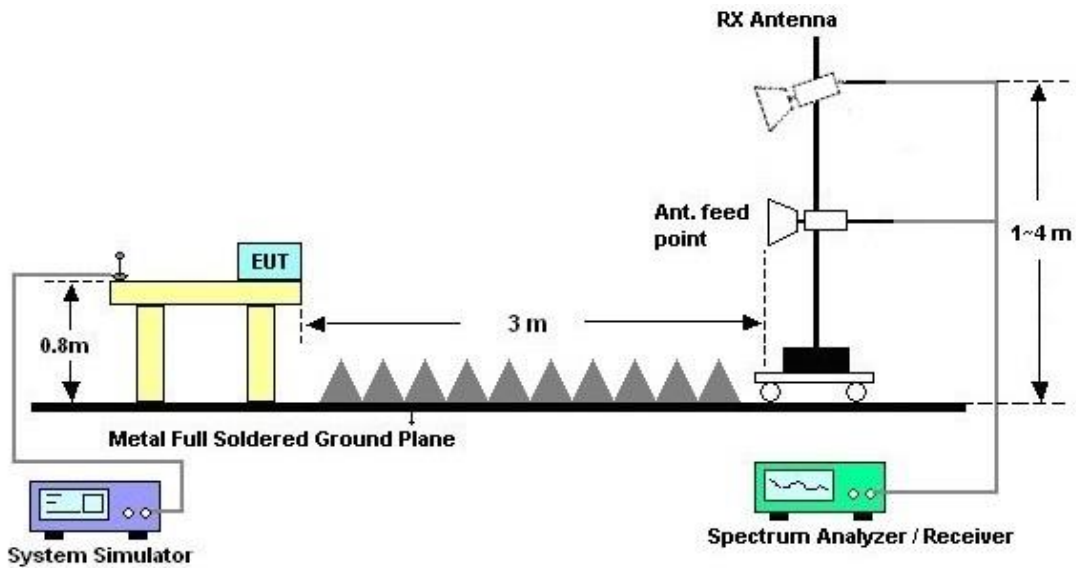



3.2.5. Test Result of Radiated Emission

Test Mode :	Mode 2	Temperature :	23~24°C
Test Engineer :	Gavin Wu	Relative Humidity :	44~45%
Test Distance :	3m	Polarization :	Horizontal
Function Type :	WCDMA Band II Idle + Bluetooth Idle + WLAN Idle + Earphone + GPS Rx + Battery + USB Cable (Data Link with Notebook)		
Remark :	#8 is system simulator signal which can be ignored.		

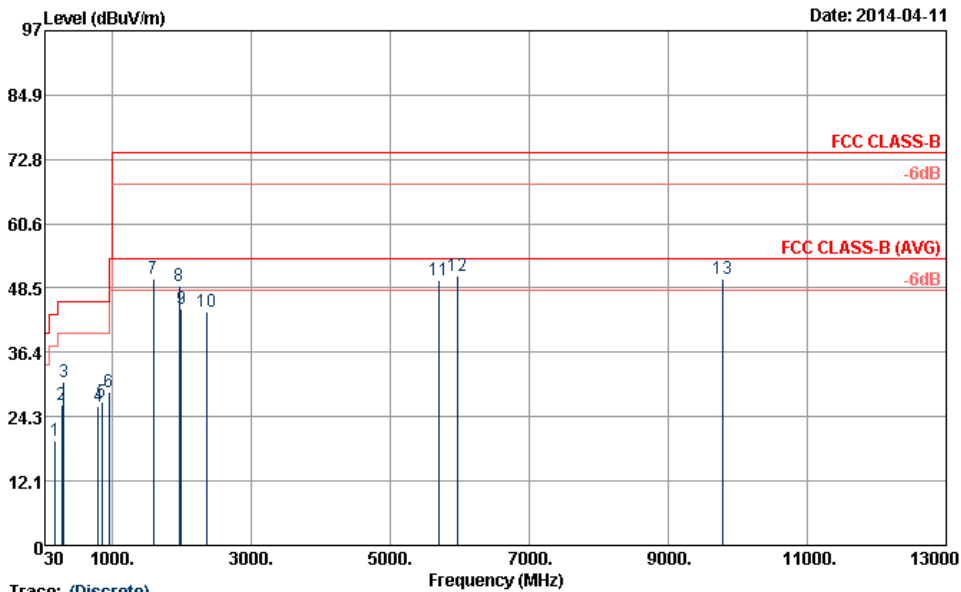

Trace: (Discrete)
 Site : 03CH06-HY
 Condition : FCC CLASS-B 3m HF-ANT_583_130802 HORIZONTAL
 Power : From System
 Mode : Mode 2

	Freq	Level	Over	Limit	ReadAntenna	Cable	Preamp	A/Pos	T/Pos	Remark
	MHz	dBuV/m	dB	dBuV/m	dBuV	dB/m	dB	dB	cm	deg
1	180.66	19.84	-23.66	43.50	40.84	9.30	1.45	31.75	---	Peak
2	268.14	26.39	-19.61	46.00	43.22	13.09	1.81	31.73	---	Peak
3	300.00	30.92	-15.08	46.00	47.53	13.20	1.91	31.72	100	207 Peak
4	800.50	26.08	-19.92	46.00	34.97	20.00	3.06	31.95	---	Peak
5	851.60	27.01	-18.99	46.00	34.70	20.80	3.24	31.73	---	Peak
6	949.60	28.92	-17.08	46.00	35.34	21.30	3.35	31.07	---	Peak
7	1596.00	50.21	-23.79	74.00	70.62	28.56	4.95	53.92	---	Peak
8	1960.00	48.98			65.83	31.35	5.79	53.99	---	Peak
9	1994.00	44.51	-29.49	74.00	61.20	31.47	5.84	54.00	---	Peak
10	2368.00	43.93	-30.07	74.00	59.55	31.89	6.42	53.93	---	Peak
11	5700.00	50.11	-23.89	74.00	60.40	34.99	11.30	56.58	---	Peak
12	5968.00	50.93	-23.07	74.00	60.58	35.27	11.77	56.69	100	0 Peak
13	9790.00	50.34	-23.66	74.00	59.14	36.55	10.57	55.92	---	Peak



Test Mode :	Mode 2	Temperature :	23~24°C
Test Engineer :	Gavin Wu	Relative Humidity :	44~45%
Test Distance :	3m	Polarization :	Vertical
Function Type :	WCDMA Band II Idle + Bluetooth Idle + WLAN Idle + Earphone + GPS Rx + Battery + USB Cable (Data Link with Notebook)		
Remark :	#9 is system simulator signal which can be ignored.		

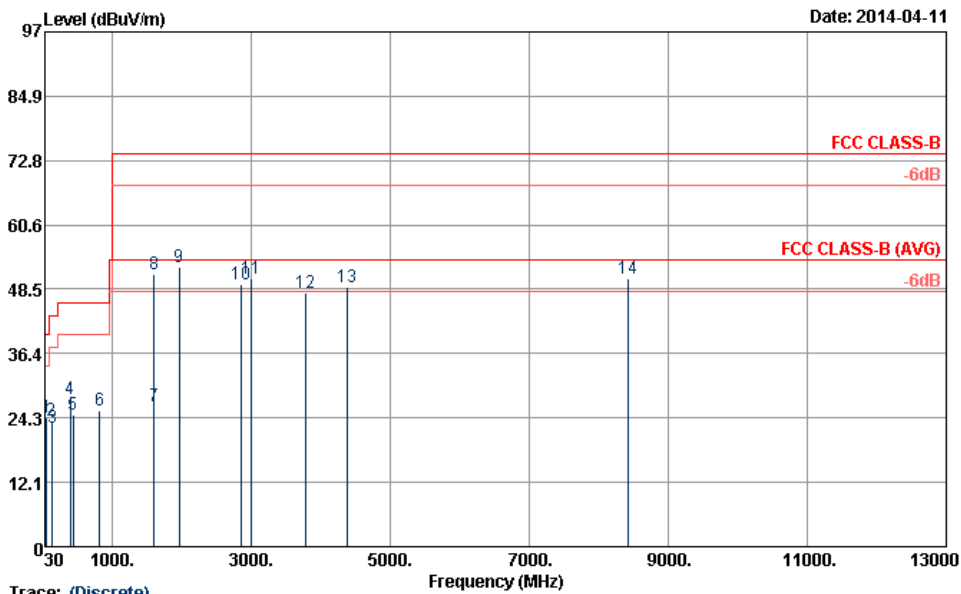

Trace: (Discrete)
 Site : 03CH06-HY
 Condition : FCC CLASS-B 3m HF-ANT_583_130802 VERTICAL
 Power : From System
 Mode : Mode 2

	Freq	Level	Over	Limit	ReadAntenna	Cable	Preamp	A/Pos	T/Pos	Remark	
	MHz	dBuV/m	dB	dBuV/m	dBuV	dB/m	dB	dB	cm	deg	
1	59.70	24.37	-15.63	40.00	48.67	6.60	0.87	31.77	100	257 Peak	
2	123.15	23.82	-19.68	43.50	42.25	12.08	1.24	31.75	---	---	Peak
3	135.30	22.51	-20.99	43.50	41.47	11.50	1.29	31.75	---	---	Peak
4	399.40	27.87	-18.13	46.00	41.70	15.80	2.19	31.82	---	---	Peak
5	438.60	24.79	-21.21	46.00	37.56	16.80	2.29	31.86	---	---	Peak
6	814.50	25.61	-20.39	46.00	34.09	20.30	3.11	31.89	---	---	Peak
7	1598.00	26.57	-27.43	54.00	46.98	28.56	4.95	53.92	100	122	Average
8	1598.00	51.42	-22.58	74.00	71.83	28.56	4.95	53.92	100	122	Peak
9	1960.00	52.73			69.71	31.22	5.79	53.99	---	---	Peak
10	2850.00	49.32	-24.68	74.00	63.50	32.49	7.30	53.97	---	---	Peak
11	2994.00	50.53	-23.47	74.00	64.26	32.68	7.59	54.00	---	---	Peak
12	3788.00	47.91	-26.09	74.00	60.79	33.15	8.54	54.57	---	---	Peak
13	4390.00	49.00	-25.00	74.00	59.87	34.32	9.79	54.98	---	---	Peak
14	8426.00	50.50	-23.50	74.00	60.28	35.60	10.75	56.13	---	---	Peak



Test Mode :	Mode 3	Temperature :	23~24°C
Test Engineer :	Gavin Wu	Relative Humidity :	44~45%
Test Distance :	3m	Polarization :	Horizontal
Function Type :	WCDMA Band II Idle + Bluetooth Idle + WLAN Idle + Earphone + GPS Rx + Battery + USB Cable (Data Link with Notebook) + Monitor		
Remark :	#8 is system simulator signal which can be ignored.		

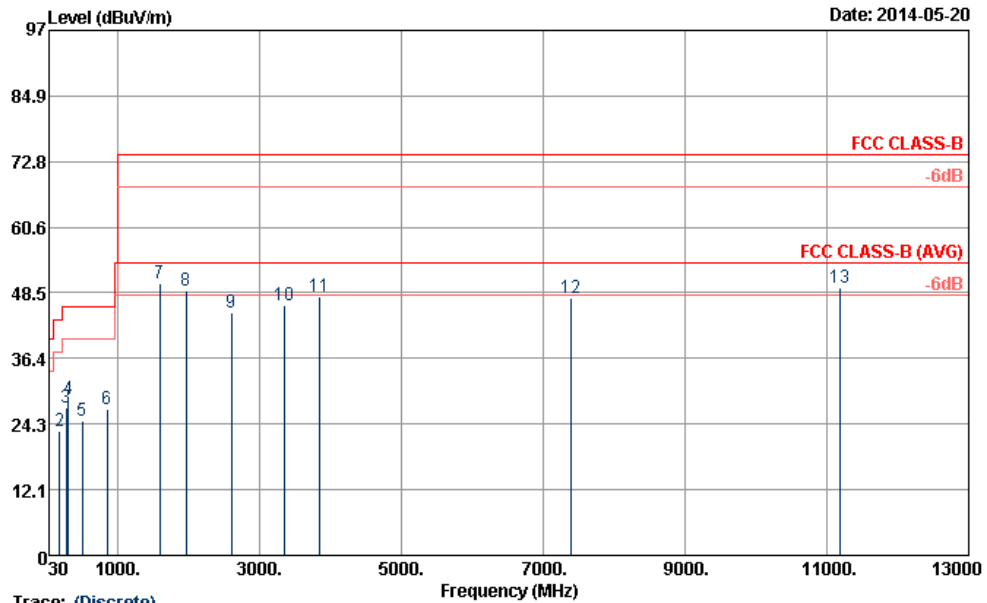

Trace: (Discrete)
 Site : 03CH06-HY
 Condition : FCC CLASS-B 3m HF-ANT_583_130802 HORIZONTAL

Power : From System
 Mode : Mode 3

	Freq	Level	Over Limit	Limit Line	ReadAntenna Level	Antenna Factor	Cable Loss	Preamp Factor	A/Pos	T/Pos	Remark
	MHz	dBuV/m	dB	dBuV/m	dBuV	dB/m	dB	dB	cm	deg	
1	35.94	19.04	-20.96	40.00	35.15	14.98	0.70	31.79	---	---	Peak
2	180.66	22.84	-20.66	43.50	43.84	9.30	1.45	31.75	---	---	Peak
3	268.14	27.39	-18.61	46.00	44.22	13.09	1.81	31.73	---	---	Peak
4	300.00	28.93	-17.07	46.00	45.54	13.20	1.91	31.72	100	215	Peak
5	499.50	24.81	-21.19	46.00	36.47	17.79	2.48	31.93	---	---	Peak
6	851.60	27.01	-18.99	46.00	34.70	20.80	3.24	31.73	---	---	Peak
7	1596.00	50.21	-23.79	74.00	70.62	28.56	4.95	53.92	100	0	Peak
8	1960.00	48.98			65.83	31.35	5.79	53.99	---	---	Peak
9	2606.00	44.84	-29.16	74.00	59.79	32.14	6.83	53.92	---	---	Peak
10	3346.00	46.21	-27.79	74.00	59.61	32.77	7.90	54.07	---	---	Peak
11	3840.00	47.71	-26.29	74.00	60.52	33.21	8.63	54.65	---	---	Peak
12	7390.00	47.55	-26.45	74.00	57.18	35.56	10.92	56.11	---	---	Peak
13	11192.00	49.40	-24.60	74.00	55.13	37.68	10.87	54.28	---	---	Peak



Test Mode :	Mode 3	Temperature :	23~24°C
Test Engineer :	Gavin Wu	Relative Humidity :	44~45%
Test Distance :	3m	Polarization :	Vertical
Function Type :	WCDMA Band II Idle + Bluetooth Idle + WLAN Idle + Earphone + GPS Rx + Battery + USB Cable (Data Link with Notebook) + Monitor		
Remark :	#8 is system simulator signal which can be ignored.		

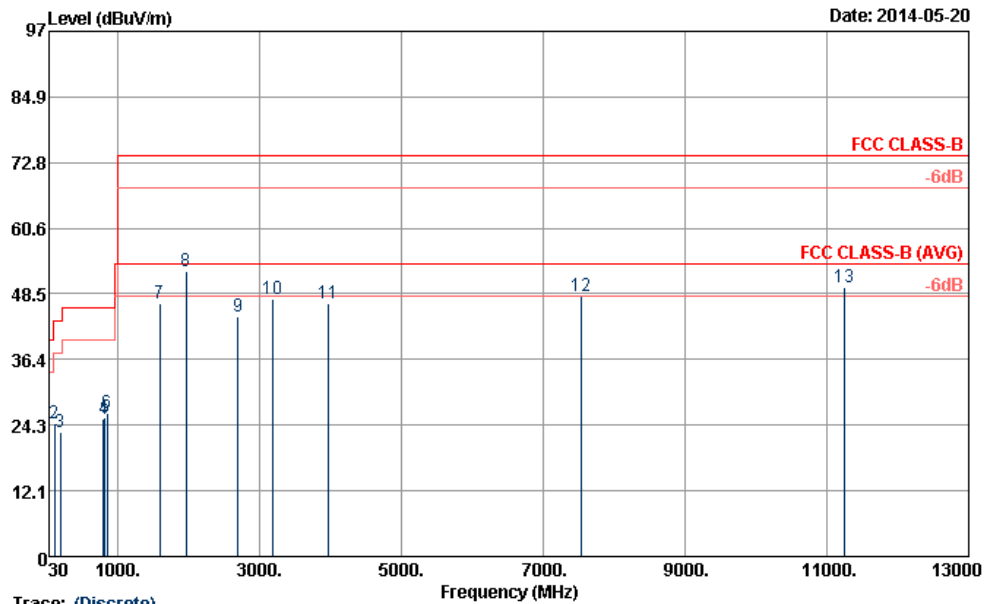

Trace: (Discrete)
 Site : 03CH06-HY
 Condition : FCC CLASS-B 3m HF-ANT_583_130802 VERTICAL

Power : From System
 Mode : Mode 3

	Freq	Level	Over Limit	Limit Line	ReadAntenna	Cable	Preamp	A/Pos	T/Pos	Remark	
	MHz	dBuV/m	dB	dBuV/m	dBuV	dB/m	dB	dB	cm	deg	
1	30.00	20.80	-19.20	40.00	33.46	18.50	0.64	31.80	---	---	Peak
2	102.36	24.61	-18.89	43.50	43.96	11.28	1.12	31.75	111	165	Peak
3	188.76	23.09	-20.41	43.50	44.28	9.08	1.48	31.75	---	---	Peak
4	798.40	25.44	-20.56	46.00	34.31	20.02	3.06	31.95	---	---	Peak
5	814.50	25.61	-20.39	46.00	34.09	20.30	3.11	31.89	---	---	Peak
6	847.40	26.49	-19.51	46.00	34.24	20.78	3.22	31.75	---	---	Peak
7	1594.00	46.82	-27.18	74.00	67.23	28.56	4.95	53.92	---	---	Peak
8	1960.00	52.73			69.71	31.22	5.79	53.99	---	---	Peak
9	2700.00	44.42	-29.58	74.00	59.06	32.28	7.02	53.94	---	---	Peak
10	3190.00	47.65	-26.35	74.00	61.19	32.74	7.76	54.04	---	---	Peak
11	3962.00	46.80	-27.20	74.00	59.44	33.36	8.84	54.84	---	---	Peak
12	7536.00	47.98	-26.02	74.00	57.47	35.51	10.89	55.89	---	---	Peak
13	11254.00	49.81	-24.19	74.00	55.41	37.70	10.90	54.20	100	0	Peak



4. List of Measuring Equipment

Instrument	Manufacturer	Model No.	Serial No.	Characteristics	Calibration Date	Test Date	Due Date	Remark
EMI Test Receiver	Rohde & Schwarz	ESCS 30	100356	9kHz ~ 2.75GHz	Nov. 15, 2013	Apr. 11, 2014~ May 21, 2014	Nov. 14, 2014	Conduction (CO05-HY)
LISN (for auxiliary equipment)	Rohde & Schwarz	ENV216	100081	9kHz ~ 30MHz	Dec. 12, 2013	Apr. 11, 2014~ May 21, 2014	Dec. 11, 2014	Conduction (CO05-HY)
LISN	Rohde & Schwarz	ENV216	100080	9kHz ~ 30MHz	Dec. 04, 2013	Apr. 11, 2014~ May 21, 2014	Dec. 03, 2014	Conduction (CO05-HY)
AC Power Source	ChainTek	APC-1000W	N/A	N/A	N/A	Apr. 11, 2014~ May 21, 2014	N/A	Conduction (CO05-HY)
Spectrum Analyzer	R&S	FSP30	101067	9kHz ~ 30GHz	Nov. 20, 2013	Apr. 11, 2014~ May 20, 2014	Nov. 19, 2014	Radiation (03CH06-HY)
Spectrum Analyzer	Agilent	E4408B	MY44211030	9kHz ~ 26.5GHz	Dec. 02, 2013	Apr. 11, 2014~ May 20, 2014	Dec. 01, 2014	Radiation (03CH06-HY)
EMI Test Receiver	R&S	ESVS10	834468/0003	20MHz ~ 1000MHz	May 06, 2013	Apr. 11, 2014	May 05, 2014	Radiation (03CH06-HY)
EMI Test Receiver	R&S	ESVS10	834468/0003	20MHz ~ 1000MHz	May 06, 2014	May 20, 2014	May 05, 2015	Radiation (03CH06-HY)
Bilog Antenna	Schaffner	CBL6112B	2885	30MHz ~ 2GHz	Oct. 10, 2013	Apr. 11, 2014~ May 20, 2014	Oct. 09, 2014	Radiation (03CH06-HY)
Double Ridge Horn Antenna	EMCO	3117	00066583	1GHz ~ 18GHz	Aug. 02, 2013	Apr. 11, 2014~ May 20, 2014	Aug. 01, 2014	Radiation (03CH06-HY)
Amplifier	SONOMA	310N	187231	9kHz ~ 1GHz	May 15, 2013	Apr. 11, 2014	May 14, 2014	Radiation (03CH06-HY)
Amplifier	SONOMA	310N	186713	9kHz ~ 1GHz	Apr. 16, 2014	May 20, 2014	Apr. 15, 2015	Radiation (03CH06-HY)
Pre Amplifier	EMCI	EMC051845	SN980048	1GHz ~ 18GHz	Jul. 18, 2013	Apr. 11, 2014~ May 20, 2014	Jul. 17, 2014	Radiation (03CH06-HY)
Turn Table	INN-CO	DS2000	420/650/00	0 ~ 360 degree	N/A	Apr. 11, 2014~ May 20, 2014	N/A	Radiation (03CH06-HY)
Antenna Mast	MF	MF-7802	MF780208212	1 m ~ 4 m	N/A	Apr. 11, 2014~ May 20, 2014	N/A	Radiation (03CH06-HY)
Loop Antenna	Rohde & Schwarz	HFH2-Z2	860004/0001	9kHz ~ 30MHz	Jul. 03, 2012	Apr. 11, 2014~ May 20, 2014	Jul. 02, 2014	Radiation (03CH06-HY)



5. Uncertainty of Evaluation

Uncertainty of Conducted Emission Measurement (150 kHz ~ 30 MHz)

Measuring Uncertainty for a Level of Confidence of 95% ($U = 2Uc(y)$)	2.26
---	------

Uncertainty of Radiated Emission Measurement (30 MHz ~ 1000 MHz)

Measuring Uncertainty for a Level of Confidence of 95% ($U = 2Uc(y)$)	4.50
---	------