

Technical Information

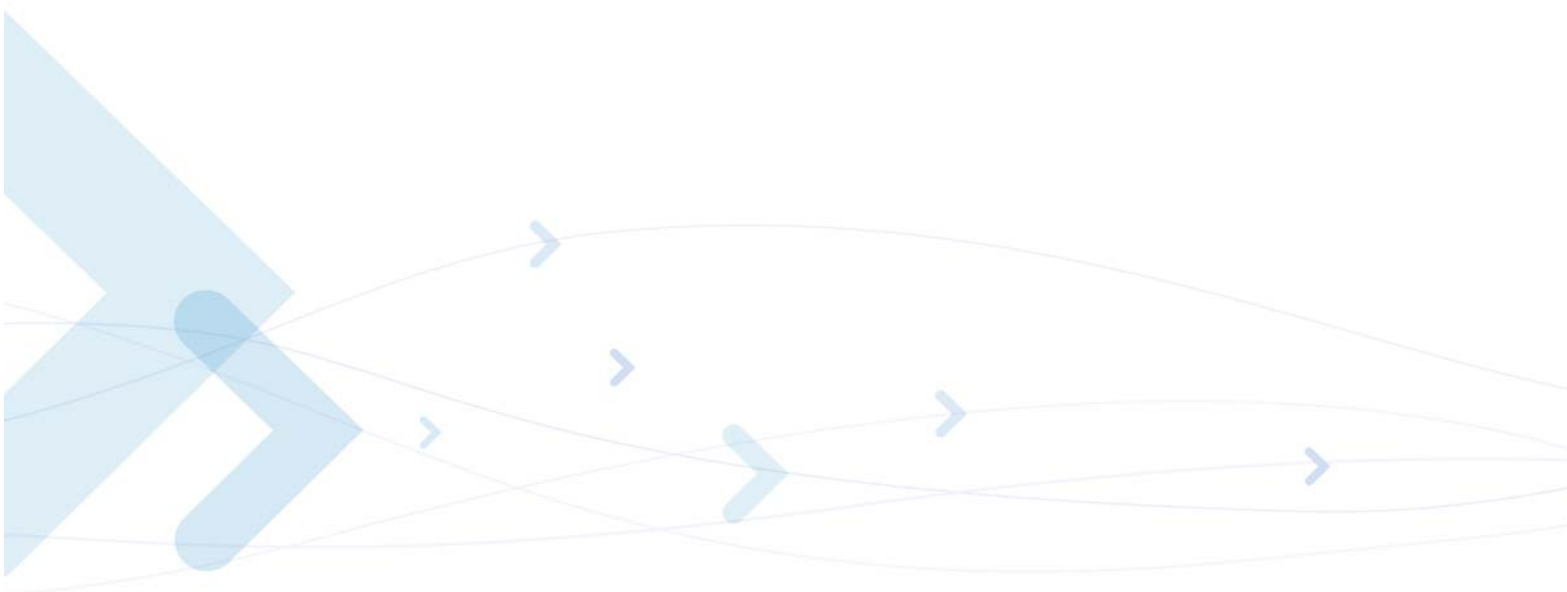

Motorola H24 Developer's Guide Module Hardware Description

NOVEMBER 15, 2009
6802986C38-D

SPECIFICATIONS SUBJECT TO CHANGE WITHOUT NOTICE

Notice

While reasonable efforts have been made to assure the accuracy of this document, Motorola, Inc. assumes no liability resulting from any inaccuracies or omissions in this document, or from use of the information obtained herein. The information in this document has been carefully checked and is believed to be entirely reliable. However, no responsibility is assumed for inaccuracies or omissions. Motorola, Inc. reserves the right to make changes to any products described herein and reserves the right to revise this document and to make changes from time to time in content hereof with no obligation to notify any person of revisions or changes. Motorola, Inc. does not assume any liability arising out of the application or use of any product, software, or circuit described herein; neither does it convey license under its patent rights or the rights of others.

It is possible that this publication may contain references to, or information about Motorola products (machines and programs), programming, or services that are not announced in your country. Such references or information must not be construed to mean that Motorola intends to announce such Motorola products, programming, or services in your country.

Copyrights

This instruction manual, and the Motorola products described in this instruction manual may be, include or describe copyrighted Motorola material, such as computer programs stored in semiconductor memories or other media. Laws in the United States and other countries preserve for Motorola and its licensors certain exclusive rights for copyrighted material, including the exclusive right to copy, reproduce in any form, distribute and make derivative works of the copyrighted material. Accordingly, any copyrighted material of Motorola and its licensors contained herein or in the Motorola products described in this instruction manual may not be copied, reproduced, distributed, merged or modified in any manner without the express written permission of Motorola. Furthermore, the purchase of Motorola products shall not be deemed to grant either directly or by implication, estoppel, or otherwise, any license under the copyrights, patents or patent applications of Motorola, as arises by operation of law in the sale of a product.

Computer Software Copyrights

The Motorola and 3rd Party supplied Software (SW) products described in this instruction manual may include copyrighted Motorola and other 3rd Party supplied computer programs stored in semiconductor memories or other media. Laws in the United States and other countries preserve for Motorola and other 3rd Party supplied SW certain exclusive rights for copyrighted computer programs, including the exclusive right to copy or reproduce in any form the copyrighted computer program. Accordingly, any copyrighted Motorola or other 3rd Party supplied SW computer programs contained in the Motorola products described in this instruction manual may not be copied (reverse engineered) or reproduced in any manner without the express written permission of Motorola or the 3rd Party SW supplier. Furthermore, the purchase of Motorola products shall not be deemed to grant either directly or by implication, estoppel, or otherwise, any license under the copyrights, patents or patent applications of Motorola or other 3rd Party supplied SW, except for the normal non-exclusive, royalty free license to use that arises by operation of law in the sale of a product.

VENDOR COPYRIGHT

Apache Software Foundation Copyright 2004-2005 All Rights Reserved

Usage and Disclosure Restrictions

License Agreements

The software described in this document is the property of Motorola, Inc. and its licensors. It is furnished by express license agreement only and may be used only in accordance with the terms of such an agreement.

Copyrighted Materials

Software and documentation are copyrighted materials. Making unauthorized copies is prohibited by law. No part of the software or documentation may be reproduced, transmitted, transcribed, stored in a retrieval system, or translated into any language or computer language, in any form or by any means, without prior written permission of Motorola, Inc.

High Risk Materials

Components, units, or third-party products used in the product described herein are NOT fault-tolerant and are NOT designed, manufactured, or intended for use as on-line control equipment in the following hazardous environments requiring fail-safe controls: the operation of Nuclear Facilities, Aircraft Navigation or Aircraft Communication Systems, Air Traffic Control, Life Support, or Weapons Systems (High Risk Activities"). Motorola and its supplier(s) specifically disclaim any expressed or implied warranty of fitness for such High Risk Activities.

Trademarks



MOTOROLA and the Stylized M Logo are registered in the US Patent & Trademark Office. All other product or service names are the property of their respective owners.

© Copyright 2009 Motorola, Inc.

REV052604

Manual Scope	vii
Target Audience	vii
Manual Organization	vii
Applicable Documents	vii
Regulatory Requirements	viii
Regulatory Statement (Safety).....	viii
FCC Notice to Users	viii
Precautions.....	ix
Antenna and Transmission Safety Precautions	ix
Standards	x
Contact Us	xi
Text Conventions.....	xi
Field Service	xiii
General Safety	xiii
Caring for the Environment.....	xiv
Limitation of Liability	xv
Warranty Notification	xv
How to Get Warranty Service?	xvi
Claiming	xvi
Conditions	xvii
What is Not Covered by the Warranty	xvii
Installed Data.....	xviii
Out of Warranty Repairs	xviii
Revision History	xix
Chapter 1: Introduction	1
Product Specifications.....	2
Regulatory Approvals	6
European Union Directives Conformance Statement	6
CFR 47 Part 15.19 specifies label requirements	6
CFR 47 Part 15.21 Information to user	7
CFR 47 Part 15.105 Information to the user	7
Chapter 2: Hardware Interface Description	9
Architecture Overview	9
Digital Block	10
Analog Block	10
RF Transceiver Block	11
WCDMA Transceiver	12
Operating Modes.....	13
Power Supply.....	14
Power Supply Design	14
Current Consumption	16
Power On/Off Operation.....	18

Turning the H24 On	18
Power Supply Turn-on	18
Turning the H24 On Using ON_N	18
Turning the H24 On Using IGN	19
Turning the H24 Off	19
Turning the H24 Off Using ON_N	19
Turning the H24 Off Using IGN	19
Power Loss shut down	19
Turning the H24 Off Using AT+MPWRDN	19
Low Power Mode	20
Activating Low Power Mode	20
Serial Interface During Low Power Mode	21
Terminating Low Power Mode	22
Temporary Termination of Low Power Mode	22
UART and USB Exiting of Low Power Mode	23
Real Time Clock	24
Serial Interfaces	25
Primary UART (UART1)	25
USB Interface	25
SIM Interface	27
External SIM Connection	27
SIM Design Guidelines	27
Embedded SIM	28
Audio Interface	29
Handset Interface	29
Headset Interface	30
Interface to an External Speaker Amplifier	31
Audio Design	32
Analog Ground	33
Digital Audio Interface	33
Voiceband Audio	33
Controls and Indicators Interface	35
Reset	35
VREF Reference Regulator	35
OFF Mode	36
Sleep Mode	36
Active Mode	36
Wakeup Out	36
Network Connection Detection	37
Transmission Indicator	38
General Purpose I/O	38
Antenna Interface	39
Chapter 3: Electrical and Environmental Specifications	41
Absolute Maximum Ratings	41
Environmental Specifications	42
Application Interface Specifications	42
Chapter 4: Mechanical Specifications	49
Board Dimensions	49
Interface Connector Specifications	50
Mating Connector	51
MMCX Connector Specifications	52
Mating Connector	52

U.FL Connector Specifications	54
Mating Connector	55
H24 Mounting	56
Chapter 5: Service and Testing.	57
Service	57
Who to Contact?	57
Required Query Information	57
Acronyms and Abbreviations	
Index	

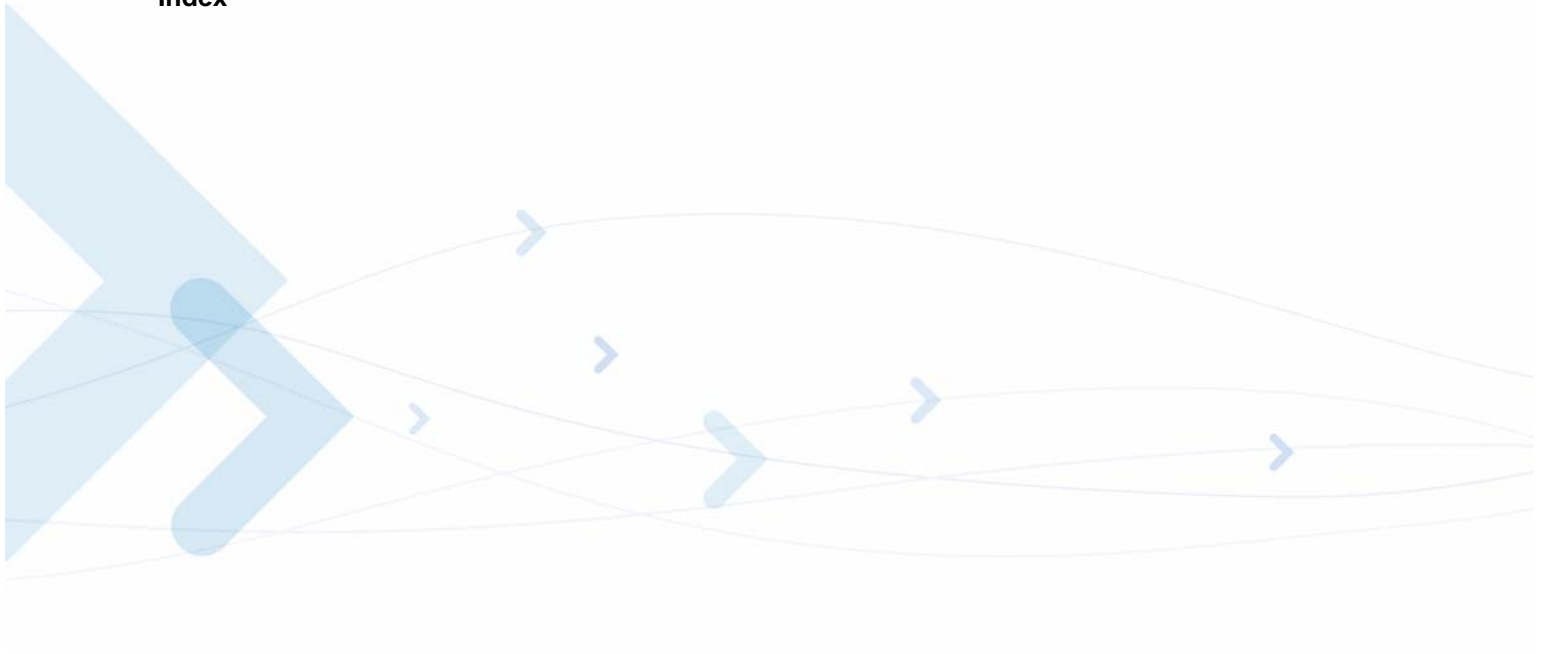

2-1	H24 Block Diagram	9
2-2	GSM and WCDMA Main Connector Block Diagram	11
2-3	WCDMA Diversity Circuitry Block Diagram	11
2-4	Transmission Power Drops	15
2-5	CTS Signal During Sleep Mode	21
2-6	Serial Interface Data	23
2-7	UART1 Interface Signals	25
2-8	USB Interface Signals	26
2-9	H24 Audio Interface	29
2-10	Handset Interface	30
2-11	Headset Interface	31
2-12	External Speaker	32
2-13	Voiceband Mode PCM Bus Coding Format	34
2-14	WKUPO_N Operation	37
2-15	TXEN_N Operation	38
4-1	H24 Mechanical Characteristics	49
4-2	H24 Interface Connector	50
4-3	Mating Connector Dimensions	51
4-4	MMCX Connector Dimensions	52
4-5	Optional MMCX Cable Assembly	53
4-6	U.FL Connector Dimensions	54
4-7	U.FL Mating Connector	55
4-8	H24 Mounting Area	56

1-1	Product Specifications	2
2-1	H24 Operating Modes	13
2-2	Power Supply Signals	14
2-3	Recommended Power Supply Filtering	15
2-4	H24 Current Ratings	16
2-5	SIM Interface Signals	27
2-6	Controls and Indicators	35
2-7	VREF Specifications	36
2-8	Antenna Interface Specifications	39
3-1	Maximum Ratings	41
3-2	Environmental Ratings	42
3-3	Interface Specifications	44
4-1	H24 interface connector options	50
4-2	Interface Connector Specifications	50
4-3	RF Connector Specifications	52
4-4	U.FL Connector Specifications	54

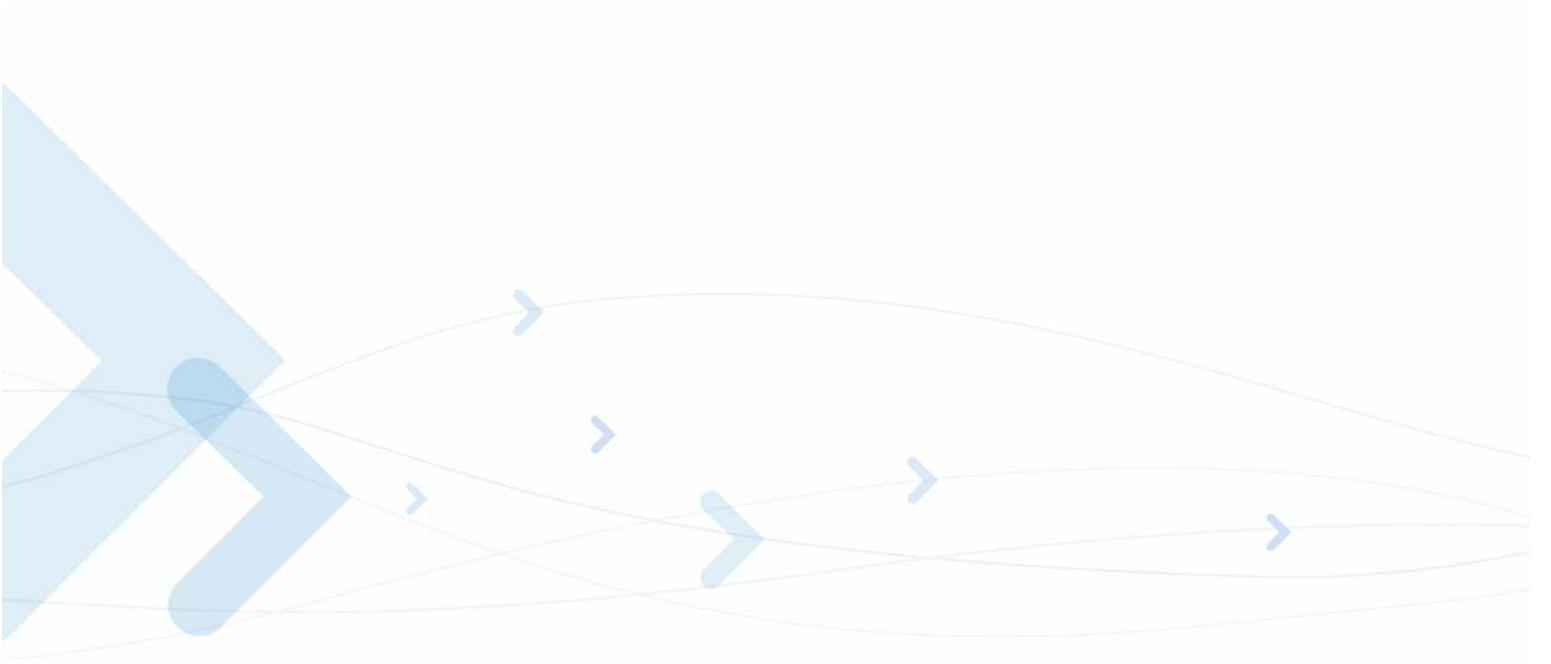

Preface

Manual Scope

This manual provides the electrical, mechanical and environmental requirements for properly integrating the H24 module in a host application.

This manual gives a complete set of hardware features and functions that may be provided by H24. The availability of any feature or function, which is described in this manual, depends on the hardware revision and software version of a specific H24 model.

The parameters and values provided in this manual are defined under typical conditions. These values may vary when subject to different conditions, such as SW version, network status, application settings and environmental conditions.

Target Audience

This manual is intended for all members of the integration team who are responsible for integrating the H24 module into the host OEM device, including representatives from hardware, software and RF engineering disciplines.

Manual Organization

This manual contains the following chapters:

- **Chapter 1**—introduces the H24 unit and provides important safety instructions.
- **Chapter 2**—provides a detailed hardware description of the blocks and components comprising the H24.
- **Chapter 3**—describes the pin assignments for H24 connectors.
- **Chapter 4**—describes H24 mechanical specifications and requirements.
- **Chapter 5**—provides contact information for Motorola Service Support and Customer Assistance.

Applicable Documents

- H24/G24 Developer's Kit - 6802986C39
- H24 AT Commands - 6802986C37

Regulatory Requirements

The Federal Communications Commission (FCC) requires application for certification of digital devices in accordance with CFR Title 47, Part 2 and Part 15. This includes MPE calculation. As the H24 modem is not a standalone transceiver but is an integrated module, the H24 cannot be tested by itself for EME certification. It is, however, the integrator's responsibility to have the completed device tested for EME certification.

Caution: Unauthorized repairs or modifications could result in permanent damage to the equipment and void your warranty and your authority to operate this device under Part 15 of the FCC Rules.

Regulatory Statement (Safety)

The following safety precautions must be observed during all phases of the operation, usage, service or repair of any cellular terminal or mobile incorporating the H24 module. Manufacturers of the cellular terminal are advised to convey the following safety information to users and operating personnel, and to incorporate these guidelines into all manuals supplied with the product. Failure to comply with these precautions violates safety standards of design, manufacture and intended use of the product. Motorola assumes no liability for customer failure to comply with these precautions.

- H24 module should not be assembled when voltage is supplied to the 70 pin connector
- H24 module must be operated at the voltages described in the technical documentation
- H24 module must not be mechanically nor electrically changed. Use of connectors should follow the guidance of the technical documentation
- H24 module is designed to meet the EMC requirements of EN 301 489-07
- When integrating the H24 module into a system, Motorola recommends testing the system to EN 301 489-07
- You must not remove any label from the H24 module
- Systems using the H24 module are subject to mandatory EMC/RF/Safety (including EME) testing under R&TTE directive 1999/5/EC ([to://www.newapproach.org/Directives/](http://www.newapproach.org/Directives/)). Other directives, such, 2002/95/EC (RoHS), WEEE Directive 2002/96/EC should also apply to a system using the H24 module

FCC Notice to Users

Motorola has not approved any changes or modifications to this device by the user. Any changes or modifications could void the user's authority to operate the equipment. See 47 CFR Sec. 15.21. This device complies with part 15 of the FCC Rules. Operation is subject to the following two conditions: (1) This device may not cause harmful interference, and (2) this device must accept any interference received, including interference that may cause undesired operation. See 47 CFR Sec. 15.19(3).

If your mobile device or accessory has a USB connector, or is otherwise considered a computer peripheral device whereby it can be connected to a computer for purposes of transferring data, then it is considered a Class B device and the following statement applies:

This equipment has been tested and found to comply with the limits for a Class B digital device, pursuant to part 15 of the FCC Rules. These limits are designed to provide reasonable protection

against harmful interference in a residential installation. This equipment generates uses and can radiate radio frequency energy and, if not installed and used in accordance with the instructions, may cause harmful interference to radio communications. However, there is no guarantee that interference will not occur in a particular installation. If this equipment does cause harmful interference to radio or television reception, which can be determined by turning the equipment off and on, the user is encouraged to try to correct the interference by one or more of the following measures:

- Reorient or relocate the receiving antenna.
- Increase the separation between the equipment and the receiver.
- Connect the equipment to an outlet on a circuit different from that to which the receiver is connected.
- Consult the dealer or an experienced radio/TV technician for help.

This device complies with Part 15 of the FCC Rules. Operation is subject to the following two conditions:

- (1) This device may not cause harmful interference.
- (2) This device must accept any interference received, including interference that may cause undesired operation.

Precautions

Interface connector and some of the module circuits are not shielded. Be sure to take appropriate precautionary measures in order to avoid ESD while handling the module. ESD can damage the H24 modules. Integrators need to design ESD protection on all external interfaces.

Antenna and Transmission Safety Precautions

User Operation

Do not operate your unit when a person is within 8 inches (20 centimeters) of the antenna. A person or object within 8 inches (20 centimeters) of the antenna could impair call quality and may cause the phone to operate at a higher power level than necessary.

Important: The unit must be installed in a manner that provides a minimum separation distance of 20 cm or more between the antenna and persons and must not be co-located or operate in conjunction with any other antenna or transmitter to satisfy FCC RF exposure requirements for mobile transmitting devices.

Important: To comply with the FCC RF exposure limits and satisfy the categorical exclusion requirements for mobile transmitters, the requirements described in the following section, “[Antenna Installation](#)”, must be met.

Antenna Installation

- The antenna installation must provide a minimum separation distance of 20 cm from users and nearby persons and must not be co-located or operating in conjunction with any other antenna or transmitter.
- Antenna installation should be done by a professional installer and should meet all FCC requirement as given in FCC part 15.
- Combined cable loss and antenna gain
 - R&TTE requirements
 - 900 MHz GSM band : The combined cable loss and antenna gain must not exceed +2.65 dBi
 - 1800 MHz DCS band : The combined cable loss and antenna gain must not exceed +7.75 dBi
 - UMTS 2100 MHz band : The combined cable loss and antenna gain must not exceed +7.75 dBi
 - FCC requirements
 - 800 MHz cellular band (WCDMA & GSM): The combined cable loss and antenna gain must not exceed +4.30 dBi for IHDT56KL1 and +3.20 dBi for IHDT56KL2
 - 1900 MHz PCS band (WCDMA & GSM): The combined cable loss and antenna gain must not exceed +2.55 dBi for IHDT56KL1 and +1.9 dBi for IHDT56KL2
 - 1700 MHz UMTS band (WCDMA): The combined cable loss and antenna gain must not exceed +5.25 dBi

OEM installers must be provided with antenna installation instruction and transmitter operating conditions for satisfying RF exposure compliance.

Section 15.203 - Antenna Requirements

An intentional radiator shall be designed to ensure that no antenna other than that furnished by the responsible party shall be used with the device. The use of a permanently attached antenna or of an antenna that uses a unique coupling to the intentional radiator shall be considered sufficient to comply with the provisions of this Section. The manufacturer may design the unit so that a broken antenna can be replaced by the user, but the use of a standard antenna jack or electrical connector is prohibited. This requirement does not apply to carrier current devices or to de-vices operated under the provisions of Sections 15.211, 15.213, 15.217, 15.219, or 15.221. Further, this requirement does not apply to intentional radiators that must be professionally installed, such as perimeter protection systems and some field disturbance sensors, or to other intentional radiators which, in accordance with Section 15.31(d), must be measured at the installation site. However, the installer shall be responsible for ensuring that the proper antenna is employed so that the limits in this Part are not exceeded.

Standards

- Electromagnetic Compatibility: Principles and Applications by David A Weston, published by Marcel Dekker, Inc., 270 Madison Avenue, New York, NY 10016 USA
- 3GPP TS 27.007-v6.9.0: AT command set for User Equipment (UE)
- 3GPP TS 27.005-v6.0.1: Use of Data Terminal Equipment - Data Circuit terminating Equipment (DTE-DCE) interface for Short Message Service (SMS) and Cell Broadcast Service (CBS)
- 3GPP TS 23.040-v6.9.0: Technical realization of Short Message Service (SMS)

- 3GPP TS 24.011-v6.1.0: Point-to-Point (PP) Short Message Service (SMS) support on mobile radio interface
- 3GPP TS 27.010-v6.0.0: Terminal Equipment to User Equipment (TE-UE) multiplexer protocol
- 3GPP TS 27.060-v6.0.0: Packet domain; Mobile Station (MS) supporting Packet Switched services
- 3GPP TS 25.304-v6.10.0: User Equipment (UE) procedures in idle mode and procedures for cell reselection in con-nected mode
- 3GPP TS 25.308-v6.4.0: High Speed Downlink Packet Access (HSDPA); Overall description; Stage 2
- 3GPP TS 25.309-v6.6.0: FDD enhanced uplink; Overall description; Stage 2
- 3GPP TS 23.038 -v6.1.0: Alphabets and language-specific information
- 3GPP TS 21.111-v6.3.0: USIM and IC card requirements
- 3GPP TS 31.111-v6.11.0 "USIM Application Toolkit (USAT)"
- 3GPP TS 45.002-v6.12.0: Multiplexing and multiple access on the radio path
- 3GPP TS 51.014-v4.5.0: Specification of the SIM Application Toolkit for the Subscriber Identity Module - Mobile Equipment (SIM - ME) interface
- 3GPP TS 51.010-1-v6.7.0: Mobile Station (MS) conformance specification; Part 1: Conformance specification
- 3GPP TS 22.004-v6.0.0: General on supplementary services
- 3GPP TS 23.090-v6.1.0: Unstructured Supplementary Service Data (USSD); Stage 2
- 3GPP TS 24.008 v6.19, Mobile radio interface Layer 3 specification;
- ITU-T V.25ter

Note: H24 is 3GPP release 6 device.

Contact Us

We at Motorola want to make this guide as helpful as possible. Keep us informed of your comments and suggestions for improvements.

For general contact, technical support, report documentation errors and to order manuals, use this email address:

M2M.CustomerCare@motorola.com

Motorola appreciates feedback from the users of our information.

Text Conventions

The following special paragraphs are used in this guide to point out information that must be read. This information may be set-off from the surrounding text, but is always preceded by a bold title in capital letters:

Note

Note: Presents additional, helpful, noncritical information that you can use.

Warning

Warning: Presents information to warn you of a potentially hazardous situation in which there is a possibility of personal injury.

Important

Important: Presents information to help you avoid an undesirable situation or provides additional information to help you understand a topic or concept.

Caution

Caution: Presents information to identify a situation in which damage to software, stored data, or equipment could occur, thus avoiding the damage.

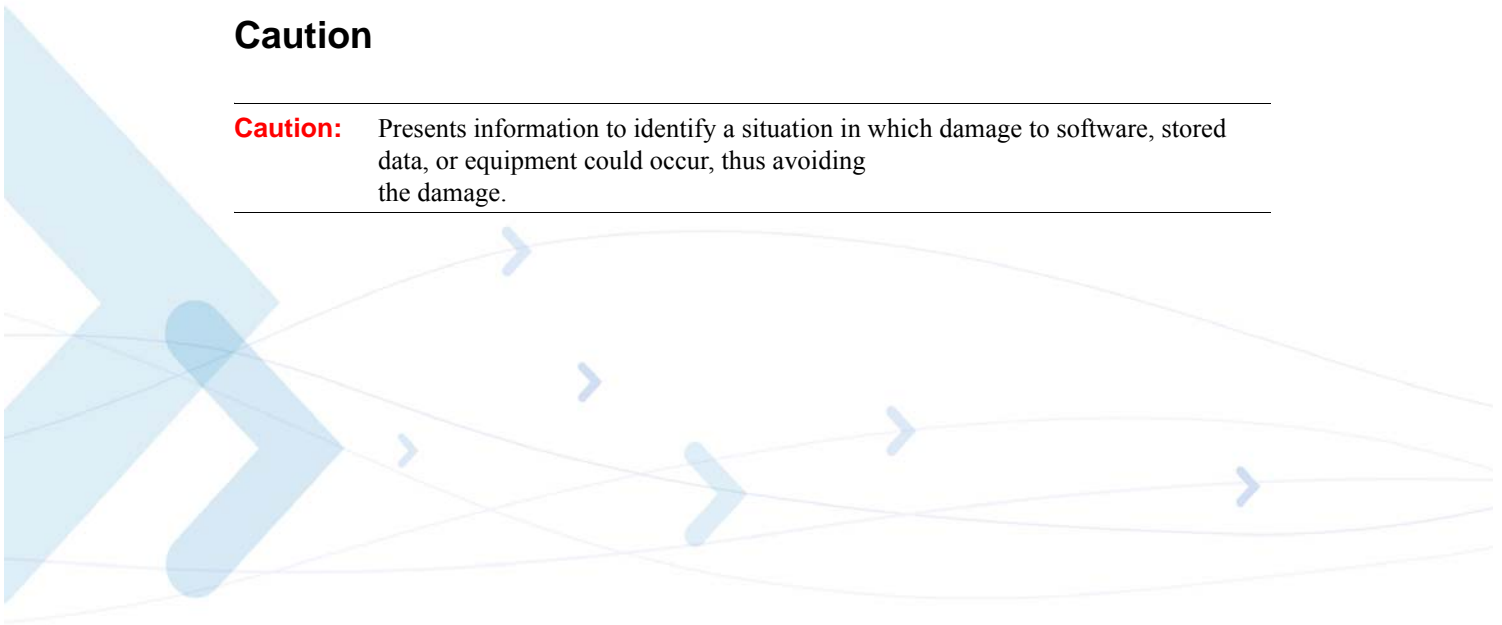

Field Service

For Field Service requests, use this email address:
n2csfs01@motorola.com

General Safety

Remember! . . . safety depends on you!

The following general safety precautions must be observed during all phases of operation, service, and repair of the equipment described in this manual. Failure to comply with these precautions or with specific warnings elsewhere in this manual violates safety standards of design, manufacture, and intended use of the equipment. Motorola, Inc. assumes no liability for the customer's failure to comply with these requirements. The safety precautions listed below represent warnings of certain dangers of which we are aware. You, as the user of this product, should follow these warnings and all other safety precautions necessary for the safe operation of the equipment in your operating environment.

Ground the instrument

To minimize shock hazard, the equipment chassis and enclosure must be connected to an electrical ground. If the equipment is supplied with a three-conductor AC power cable, the power cable must be either plugged into an approved three-contact electrical outlet or used with a three-contact to two-contact adapter. The three-contact to two-contact adapter must have the grounding wire (green) firmly connected to an electrical ground (safety ground) at the power outlet. The power jack and mating plug of the power cable must meet International Electrotechnical Commission (IEC) safety standards.

Note: Refer to "*Grounding Guideline for Cellular Radio Installations*"—Motorola part no. *68P081150E62*.

Do not operate in an explosive atmosphere

Do not operate the equipment in the presence of flammable gases or fumes. Operation of any electrical equipment in such an environment constitutes a definite safety hazard.

Do not service or adjust alone

Do not attempt internal service or adjustment unless another person, capable of rendering first aid is present.

Keep away from live circuits

Operating personnel must:

- not remove equipment covers. Only Factory Authorized Service Personnel or other qualified maintenance personnel may remove equipment covers for internal subassembly, or component replacement, or any internal adjustment

- not replace components with power cable connected. Under certain conditions, dangerous voltages may exist even with the power cable removed
- always disconnect power and discharge circuits before touching them

Do not substitute parts or modify equipment

Because of the danger of introducing additional hazards, do not install substitute parts or perform any unauthorized modification of equipment. Contact Motorola Warranty and Repair for service and repair to ensure that safety features are maintained.

Dangerous procedure warnings

Warnings, such as the example below, precede potentially dangerous procedures throughout this manual. Instructions contained in the warnings must be followed. You should also employ all other safety precautions that you deem necessary for the operation of the equipment in your operating environment.

Warning example:

Warning: Dangerous voltages, capable of causing death, are present in this equipment. Use extreme caution when handling, testing, and adjusting.

Caring for the Environment

The following information is provided to enable regulatory compliance with the European Union (EU) Directive [2002/96/EC Waste Electrical and Electronic Equipment \(WEEE\)](#) when using Motorola equipment in EU countries.

Disposal of Motorola equipment in EU countries



Please do not dispose of Motorola equipment in landfill sites.

In the EU, Motorola in conjunction with a recycling partner will ensure that equipment is collected and recycled according to the requirements of EU environmental law.

Please contact the Customer Network Resolution Center (CNRC) for assistance. The 24 hour telephone numbers are listed at

<http://mynetworksupport.motorola.com>

Select **Customer Network Resolution Center contact information**.

Alternatively if you do not have access to CNRC or the internet, contact the Local Motorola Office.

Disposal of Motorola equipment in non-EU countries

In non-EU countries, dispose of Motorola equipment in accordance with national and regional regulations.

Turkey

Article 7 of the *European Union (EU) Directive 2002/96/EC Waste Electrical and Electronic Equipment (WEEE)*

The Government of Turkey requests a statement of conformity with the EEE regulation be provided with this equipment. This statement of EEE conformity (in Turkish) is: **EEE Yönetmeliğine Uygundur.**

Limitation of Liability

The Products are not designed, intended, or authorized for use as components in systems intended for surgical implant into the body; in other applications intended to support or sustain life; for the planning, construction, maintenance, operation or use of any nuclear facility; for the flight, navigation, communication of aircraft or ground support equipment; or in any other application in which the failure of the Product could create a situation where personal injury or death may occur. If CUSTOMER should use any Product or provide any Product to a third party for any such use, CUSTOMER hereby agrees that MOTOROLA is not liable, in whole or in part, for any claims or damages arising from such use, and further agrees to indemnify and hold MOTOROLA harmless from any claim, loss, cost or damage arising from such use.

EXCEPT AS SPECIFICALLY STATED ABOVE, THE PRODUCTS ARE PROVIDED "AS IS" AND MOTOROLA MAKES NO OTHER WARRANTIES EXPRESS, IMPLIED, STATUTORY, OR OTHERWISE REGARDING THE PRODUCTS. MOTOROLA SPECIFICALLY DISCLAIMS ANY IMPLIED WARRANTIES OF MERCHANTABILITY AND FITNESS FOR A PARTICULAR PURPOSE, OR ARISING FROM A COURSE OF DEALING OR USAGE OF TRADE.

Under no circumstances shall MOTOROLA be liable to CUSTOMER or any other party for any costs, lost revenue or profits or for any other special, incidental or consequential damages, even if MOTOROLA has been informed of such potential loss or damage. And in no event shall MOTOROLA's liability to CUSTOMER for damages of any nature exceed the total purchase price CUSTOMER paid for the Product at issue in the dispute, except direct damages resulting from patent and/or copyright infringement, which shall be governed by the "INDEMNITY" Section of this Agreement.

The preceding states MOTOROLA's entire liability for MOTOROLA's breach or failure to perform under any provision of this Agreement.

Warranty Notification

Motorola guarantees to you, the original purchaser, the OEM module and accessories which you have purchased from an authorized Motorola dealer (the "Products"), to be in conformance with the applicable Motorola specifications current at the time of manufacture for a term of [1] year from date of purchase of the Product(s) (Warranty Term).

You must inform Motorola of the lack of conformity to the applicable specifications of any of the Products within a period of two (2) months from the date on which you detect a defect in material, workmanship or lack of conformity and in any event within a term not to exceed the Warranty Term, and must immediately submit the Product for service to Motorola's Authorized Repair or Service Center. Motorola shall not be bound by Product related statements not directly made by Motorola nor any warranty obligations applicable to the seller.

A list of the Motorola Call Center numbers is enclosed with this Product.

During the Warranty term, Motorola will, at its discretion and without extra charge, as your exclusive remedy, repair or replace your Product which does not comply with this warranty; or failing this, to reimburse the price of the Product but reduced to take into account the use you have had of the Product since it was delivered. This warranty will expire at the end of the Warranty Term.

This is the complete and exclusive warranty for a Motorola OEM module and accessories and in lieu of all other warranties, terms and conditions, whether express or implied.

Where you purchase the product other than as a consumer, Motorola disclaims all other warranties, terms and conditions express or implied, such as fitness for purpose and satisfactory quality.

In no event shall Motorola be liable for damages nor loss of data in excess of the purchase price nor for any incidental special or consequential damages* arising out of the use or inability to use the Product, to the full extent such may be disclaimed by law.

This Warranty does not affect any statutory rights that you may have if you are a consumer, such as a warranty of satisfactory quality and fit for the purpose for which products of the same type are normally used under normal use and service, nor any rights against the seller of the Products arising from your purchase and sales contract.

(*including without limitation loss of use, loss of time, loss of data, inconvenience, commercial loss, lost profits or savings.

How to Get Warranty Service?

In most cases the authorized Motorola dealer which sold and/or installed your Motorola OEM module and original accessories will honor a warranty claim and/or provide warranty service. Alternatively, for further information on how to get warranty service please contact either the customer service department of your service provider or Motorola's service centers, listed in Chapter 5.

Claiming

In order to claim the warranty service you must return the OEM module and/or accessories in question to Motorola's Authorized Repair or Service Center in the original configuration and packaging as supplied by Motorola. Please avoid leaving any supplementary items like SIM cards. The Product should also be accompanied by a label with your name, address, and telephone number; name of operator and a description of the problem.

In order to be eligible to receive warranty service, you must present your receipt of purchase or a comparable substitute proof of purchase bearing the date of purchase. The phone should also clearly display the original compatible electronic serial number (IMEI) and mechanic serial number [MSN]. Such information is contained with the Product.

You must ensure that all and any repairs or servicing is handled at all times by a Motorola Authorized Service Center in accordance with the Motorola Service requirements

In some cases, you may be requested to provide additional information concerning the maintenance of the Products by Motorola Authorized Service Centers only, therefore it is important to keep a record of any previous repairs, and make them available if questions arise concerning maintenance.

Conditions

This warranty will not apply if the type or serial numbers on the Product has been altered, deleted, duplicated, removed, or made illegible. Motorola reserves the right to refuse free-of-charge warranty service if the requested documentation can not be presented or if the information is incomplete, illegible or incompatible with the factory records.

Repair, at Motorola's option, may include reflashing of software, the replacement of parts or boards with functionally equivalent, reconditioned or new parts or boards. Replaced parts, accessories, batteries, or boards are warranted for the balance of the original warranty time period. The Warranty Term will not be extended. All original accessories, batteries, parts, and OEM module equipment that have been replaced shall become the property of Motorola. Motorola does not warrant the installation, maintenance or service of the products, accessories, batteries or parts.

Motorola will not be responsible in any way for problems or damage caused by any ancillary equipment not furnished by Motorola which is attached to or used in connection with the Products, or for operation of Motorola equipment with any ancillary equipment and all such equipment is expressly excluded from this warranty.

When the Product is used in conjunction with ancillary or peripheral equipment not supplied by Motorola, Motorola does not warrant the operation of the Product/peripheral combination and Motorola will not honor any warranty claim where the Product is used in such a combination and it is determined by Motorola that there is no fault with the Product. Motorola specifically disclaims any responsibility for any damage, whether or not to Motorola equipment, caused in any way by the use of the OEM module, accessories, software applications and peripherals (specific examples include, but are not limited to: batteries, chargers, adapters, and power supplies) when such accessories, software applications and peripherals are not manufactured and supplied by Motorola.

What is Not Covered by the Warranty

This warranty is not valid if the defects are due to damage, misuse, tampering, neglect or lack of care and in case of alterations or repair carried out by unauthorized persons.

The following are examples of defects or damage not covered by this product warranty

1. Defects or damage resulting from use of the Product in other than its normal and customary manner.
2. Defects or damage from misuse, access to incompatible sources, accident or neglect.
3. Defects or damage from improper testing, operation, maintenance, installation, adjustment, unauthorized software applications or any alteration or modification of any kind.
4. Breakage or damage to antennas unless caused directly by defects in material or workmanship.

5. Products disassembled or repaired other than by Motorola in such a manner as to adversely affect performance or prevent adequate inspection and testing to verify any warranty claim.
6. Defects or damage due to range, coverage, availability, grade of service, or operation of the cellular system by the cellular operator.
7. Defects or damage due to moist, liquid or spills of food.
8. Control unit coil cords in the Product that are stretched or have the modular tab broken.
9. All plastic surfaces and all other externally exposed parts that are scratched or damaged due to customer normal use.

Depending on operating conditions and your usage habits, wear and tear might take place of components including mechanical problems related to Product housing, paint, assembly, sub-assemblies, displays and keyboards and any accessories which are not part of the Product's in-box configuration. The rectification of faults generated through wear and tear and the use of consumable items like batteries beyond their Optimum Performance Time as indicated in the product manual is considered to be your responsibility and therefore Motorola will not provide the free Warranty repair service for these items

Installed Data

Please make and retain a note of all data you have inserted into your Product for example names, addresses, phone numbers, user and access codes, notes etc. before submitting your Product for a Warranty service as such data may be deleted or erased as part of the repair or service process.

Please note if you have downloaded material onto your product, these may be deleted or erased as part of the repair process or testing process. Motorola shall not be responsible for such matters. The repair or testing process should not affect any such material that was installed by Motorola on your Product as a standard feature.

Out of Warranty Repairs

If you request Motorola to repair your Product any time after the Warranty term or where this warranty does not apply due to the nature of the defect or fault, then Motorola may in its discretion carry out such repairs subject to you paying Motorola its fees for such a repair or it may refer you to an authorized third party to carry out such repairs.

Revision History

Manual Number

6802986C38-C

Manual Title

H24 - Module Hardware Description

Version Information

The following table lists the manual version, date of version, and remarks about the version.

Revision History

Version	Date Issue	Remarks
A	January 15, 2009	Initial Release
B	May 15, 2009	Minor updates throughout the manual
C	August 31, 2009	Major update of the manual
D	November 15, 2009	

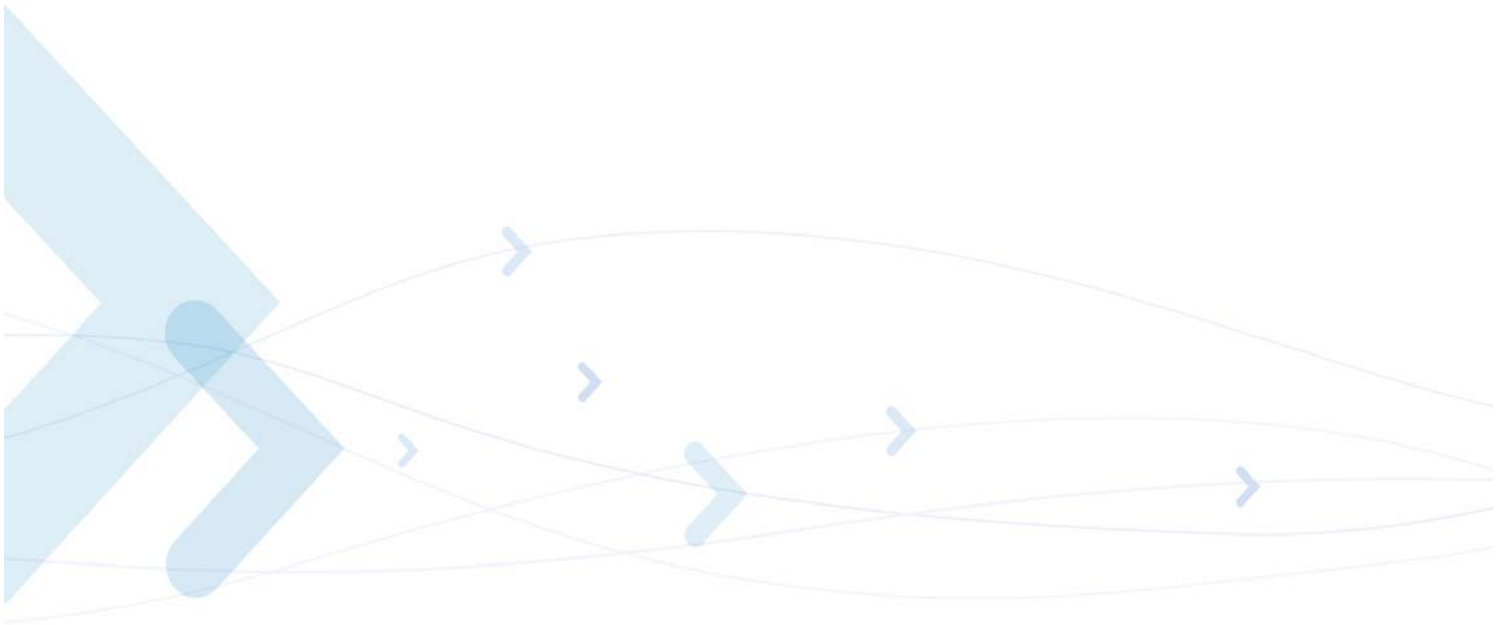

Chapter 1: Introduction

The H24 is the newest member of Motorola's embedded cellular modules family.

Designed with Tri bands WCDMA & quad band GSM capabilities, which supports WCDMA bands: B1-2100, B2-1900, B5 -850 with HSPA capability and four GSM bands - 850/900/1800/1900 MHz, with GPRS/EGPRS multislot class 12. H24 can operate on any GSM/GPRS/EGPRS/WCDMA/HSPA network to provide voice and data communications.

The H24 is similar to a condensed cellular phone core, which can be integrated into any system or product that needs to transfer voice or data information over a cellular network. Thus, it significantly enhances the system's capabilities, transforming it from a standalone, isolated product to a powerful high-performance system with global communications capabilities.

The H24 is designed as a complete GSM/WCDMA communications solution with all the controls, interfaces and features to support a broad range of applications:

- A powerful audio interface
- A large set of indicators and control signals
- Several advanced power-saving modes
- A variety of serial communications solutions.

All these features and interfaces are easily controlled and configured using a versatile AT command interface that provides full control over the H24 operation.

The H24 control and indication interface extends its capabilities beyond GSM communications. This includes an A/D and GPIO interface, and a regulated output voltage for supplying external circuits. With these interfaces, the H24 can operate and control external applications and receive feedback from external environment and circuits.

The H24 interface design, using a single 70 pin board-to-board connector, through which all application interfaces are managed, facilitates fast and easy integration. It significantly shortens the development process, and minimizes the product's time to market.

The H24 is extremely compact in size with a slim mechanical design, which makes it space saving on the application board and easily fitted into any board design.

The advanced power supply management significantly reduces power consumption to a necessary minimum and prolongs battery life.

Product Specifications

Important: For safety regulations and requirements, see “Regulatory Requirements” on page viii, “Regulatory Statement (Safety)” on page viii and “Antenna and Transmission Safety Precautions” on page ix in “Preface” .

Note: Motorola reserves the right to change the specifications without prior notice.

Table 1-1: Product Specifications

Product Features	
Operating systems:	GSM: GSM 850/GSM 900 DCS 1800/PCS 1900 WCDMA: B1 - 2100 B2 - 1900 B4 - 1700 B5 - 850
Physical Characteristics	
Size (with 3 mm connector):	45.2 x 24.4 x 5.4 mm
Mounting:	Two Ø2.4 mm holes
Weight:	10 grams

Table 1-1: Product Specifications (Cont.)

Environmental	
Operational temperature:	-30°C to +65°C
Restricted Operational Temperature:	-30°C to +85°C (For more details please contact M2M.CustomerCare@motorola.com)
Storage temperature:	-40°C to +85°C
Performance	
Operating voltage:	3.3 - 4.2 V
Current consumption:	In AT mode: 1.4 mA @ DRX9 (Sleep mode)
Maximum Tx output power:	GSM 850/GSM 900: Power class 4 (33 ± 2dBm) DCS 1800/PCS 1900: Power class 1 (30 ± 2 dBm) GSM 850/GSM 900: GPRS 4 slot up (28 ± 2 dBm) DCS 1800/PCS 1900: GPRS 4 slot up (25 ± 2 dBm) GSM 850/GSM 900: EGPRS 4 slot up (22 ± 2 dBm) DCS 1800/PCS 1900: EGPRS 4 slot up (21 ± 2 dBm) WCDMA/HSDPA/HSUPA B1 , B2, B4, B5: Power class 3 (24 dBm+ 1 /-3 dB)
Interfaces	
Connectors:	Single 70-pin, board-to-board RF MMCX 2 RF UFL Connectors (Diversity , GPS)
SIM Card:	External USIM connectivity 1.8V/3.0 V
Serial Ports:	UART: BR up to 4M bps RS232 supported USB: USB High-Speed device specifications, Rev. 2.0
Data Features	
GPRS:	Multi-slot class 12 (4 Rx/4 Tx/5 Sum) Max air Downlink BR 80 kbps Coding scheme CS1-CS4 Class B
EGPRS (model dependant):	Multi-slot class 12 Max air Downlink BR 236 kbps Coding scheme MCS1-MCS9 Class B
CSD:	Max BR 14.4 kbps
SMS:	MO/MT Text and PDU modes Cell broadcast
Voice Features	
Telephony	
Digital audio	H24 PCM bus can be set also as Slave or Continues mode. Clock: 2048 kHz, frame sync clock: 8 kHz .

Table 1-1: Product Specifications (Cont.)

Differential analog audio lines	
Vocoders	EFR/HR/FR/AMR
DTMF support	
Audio control:	Echo suppression, noise suppression, side tone, gain control and filter control



Table 1-1: Product Specifications (Cont.)

GSM Supplementary Service
Call forwarding
Call hold, waiting and multiparty
Call barring
Character Set
UCS2
IRA
GSM
Control/Status Indicators
GSM/GPRS/EGPRS WCDMA/HSDPA/HSUPA coverage
Wakeup
TX enable
Reset
Data Services
Embedded TCP/IP stack
PPP Dialup networking
Circuite switch data calls
AT Command Set
GSM 07.05
GSM 07.07
Motorola proprietary AT commands
Accessories
Flashing tool
Data logger
Developer Kit

Regulatory Approvals

The H24 module has been tested and approved under the standards and regulations listed below:

- FCC
- IC
- PTCRB
- R&TTE directive
- EMC Directive
- GCF
- BABT
- RoHS

European Union Directives Conformance Statement



Hereby, Motorola declares that this product is in compliance with

- The essential requirements and other relevant provisions of Directive 1999/5/EC
- All other relevant EU Directives

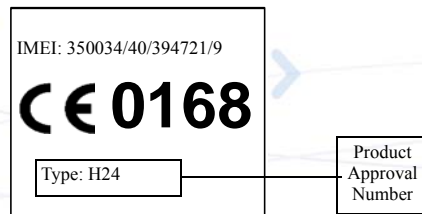

The above gives an example of a typical Product Approval Number.

You can view your product's Declaration of Conformity (DoC) to Directive 1999/5/EC (the R&TTE Directive) at www.motorola.com/rtte - to find your DoC, enter the product Approval Number from your product's label in the "Search" bar on the Web site.

Important: The following paragraphs must be addressed by the integrator to ensure their host is in compliance to the H24 FCC grant and/or the FCC grant of the host device.

CFR 47 Part 15.19 specifies label requirements

The following text may be on the product, user's manual, or container.

This device complies with Part 15 of the FCC Rules. Operation is subject to the following two conditions: (1) this device may not cause harmful interference, and (2) this device must accept any interference received, including interference that may cause undesired operation.

CFR 47 Part 15.21 Information to user

The user's manual or instruction manual for an intentional or unintentional radiator shall caution the user that changes or modifications not expressly approved by the party responsible for compliance could void the user's authority to operate the equipment. In cases where the manual is provided only in a form other than paper, such as on a computer disk or over the Internet, the information required by this section may be included in the manual in that alternative form, provided the user can reasonably be expected to have the capability to access information in that form.

CFR 47 Part 15.105 Information to the user

(b) For a Class B digital device or peripheral, the instructions furnished the user shall include the following or similar statement, placed in a prominent location in the text of the manual:

Note: This equipment has been tested and found to comply with the limits for a Class B digital device, pursuant to Part 15 of the FCC Rules. These limits are designed to provide reasonable protection against harmful interference in a residential installation. This equipment generates, uses and can radiate radio frequency energy and, if not installed and used in accordance with the instructions, may cause harmful interference to radio communications. However, there is no guarantee that interference will not occur in a particular installation. If this equipment does cause harmful interference to radio or television reception, which can be determined by turning the equipment off and on, the user is encouraged to try to correct the interference by one or more of the following measures:

- Reorient or relocate the receiving antenna.
- Increase the separation between the equipment and receiver.
- Connect the equipment into an outlet on a circuit different from that to which the receiver is connected.
- Consult the dealer or an experienced radio/TV technician for help.



Chapter 2: Hardware Interface Description

The following paragraphs describe in details the hardware requirements for properly interfacing and operating the H24 module.

Architecture Overview

Figure 2-1 below illustrates the primary functional components of the H24.

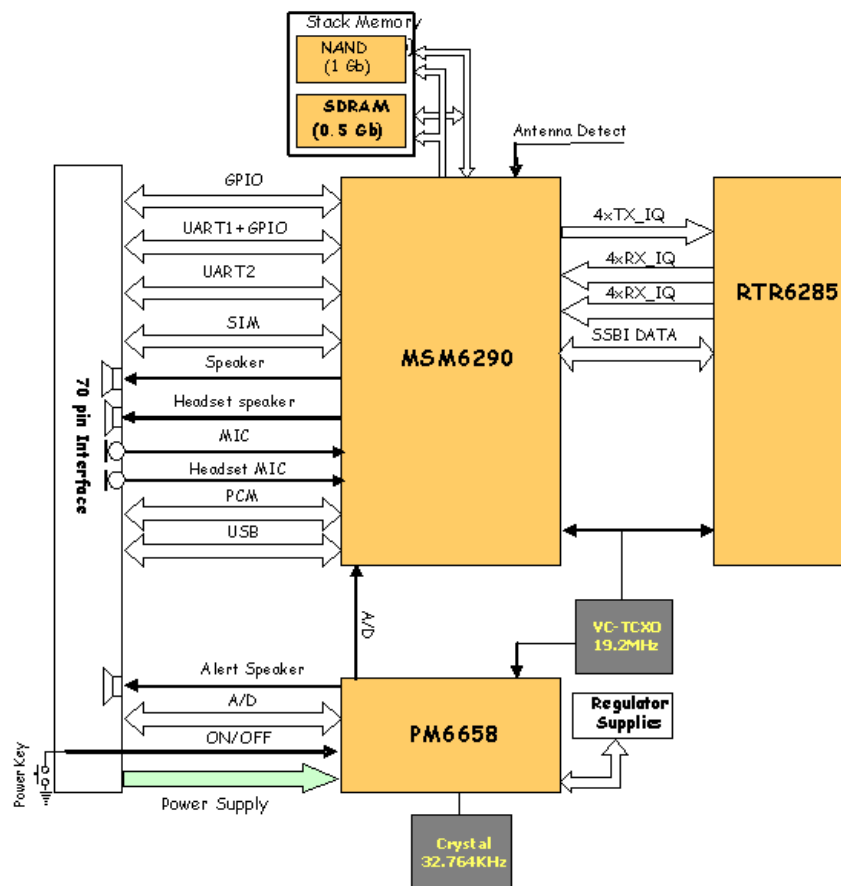

Figure 2-1: H24 Block Diagram

The H24 consists of the following blocks:

Digital Block

- Micro-controller Unit (MCU) for system and user code execution.
- Digital Signal Processor (DSP) for voice and data processing.
- Serial communications interfaces.
 - USB driver interface
 - UART1
 - UART2
 - I2C
 - SIM card
- Digital audio (PCM) bus interface.
- General purpose IO signals.

Analog Block

- Power Management IC (PMIC).
 - Internal regulators
 - 1 external regulator for customer use
- Analog audio interface management.
 - Speaker, microphone
 - Alert speaker
 - Headset
- General purpose and dedicated A/D signals.
 - A/D
 - Voltage sensor
 - Temperature sensor
- Real Time Clock (RTC) subsystem.

RF Transceiver Block

Figure 2-2 and Figure 2-3 give a detailed RF block diagram.

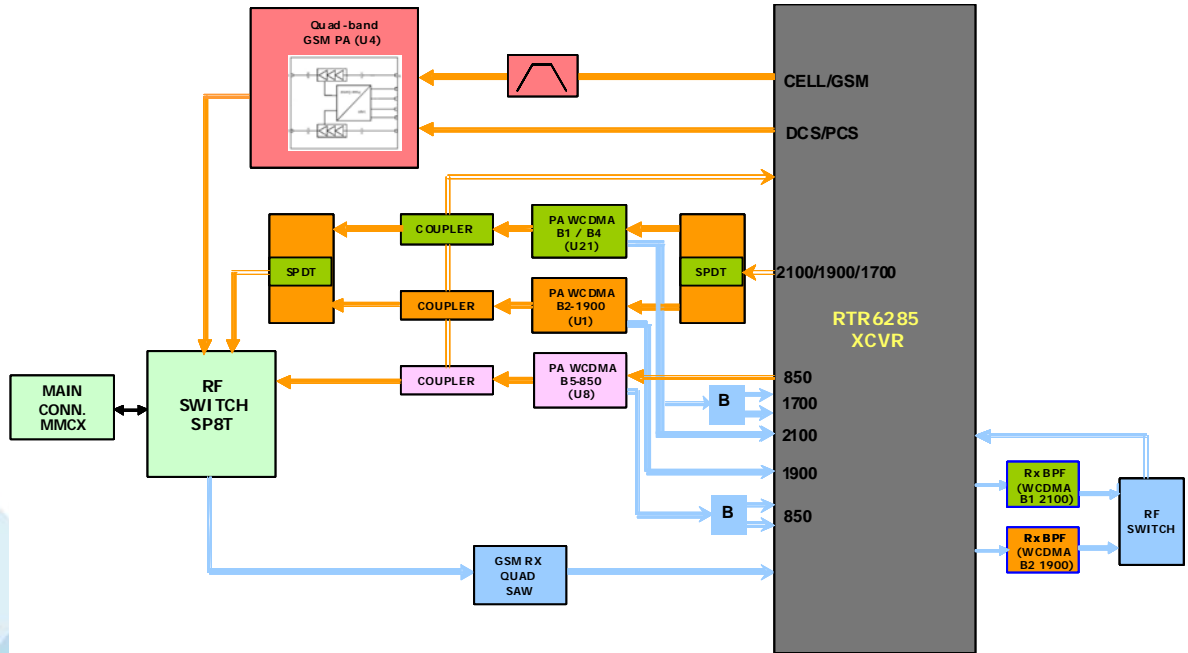

Figure 2-2: GSM and WCDMA Main Connector Block Diagram

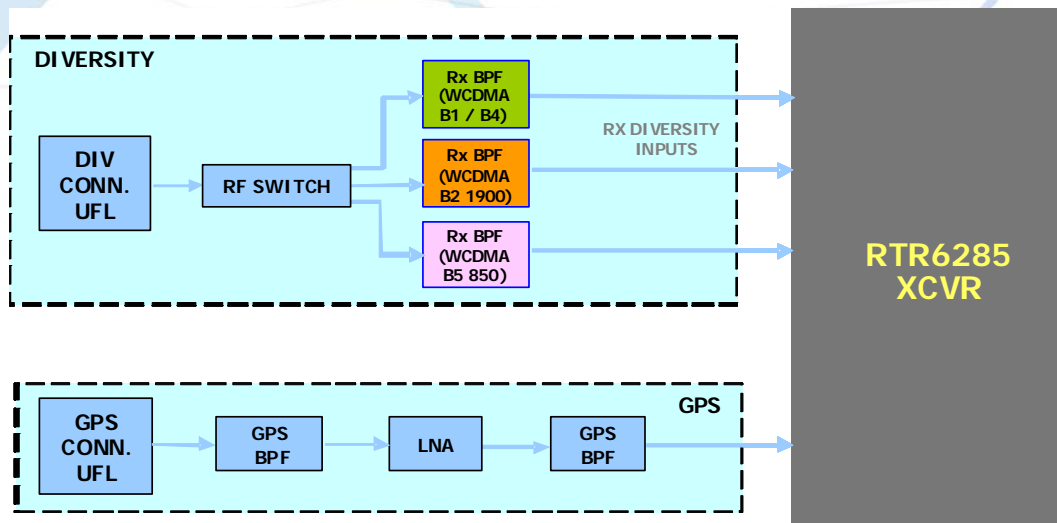

Figure 2-3: WCDMA Diversity Circuitry Block Diagram

Note: GPS is not supported in the current version.

WCDMA Transceiver

- RTR6285 includes: modulator, receiver, LNAs, Mixers, VCOs, I/Q outputs and buffers for all WCDMA bands.
- Three RF Power Amplifiers for B1-2100 or B4-1700, B2-1900 & B5 - 850.
- Three couplers for feedback into the Modulator for each band.
- RF Switch SP9T for selecting corrected path to and from main MMCX connector.
- Receive path is inside PA via internal duplexer into the RTR.
- Internal LNAs for all WCDMA bands inside RTR
- External switch, RF SPDT, from WB1900 & WB2100 LNA's output into one receiver's differential input.
- Diversity path: From Diversity UFL connector via SP3T into SAW filter for WB2100/W1700, WB1900 & WB850 fed into secondary receivers inputs inside the RTR.



Operating Modes

H24 incorporates several operating modes. Each operating mode is different in the active features and interfaces.

Table 2-1 summarizes the general characteristics of the H24 operating modes and provides general guidelines for operation.

Table 2-1: H24 Operating Modes

Mode	Description	Features
Not Powered	VCC supply is disconnected.	The H24 is Off. Any signals connected to the interface connector must be set low or tri-state.
Off Mode	Valid VCC supply. RESET_N signal is enabled (low).	The H24 Interfaces are Off. Only the internal RTC timer is operating. Any signals connected to the interface connector must be set low or tri-stated.
Idle Mode	RESET_N signal is disabled (high). CTS_N and DSR_N signals are enabled (low).	The H24 is fully active, registered to the GSM network and ready to communicate. This is the default power-up mode.
Sleep Mode	RESET_N signal is high. CTS_N signal is disabled.	The H24 is in low power mode. The application interfaces are disabled, but, H24 continues to monitor the GSM network.
CSD call or GPRS/EGPRS data	RESET_N signal is high. TXEN_N signal is toggling.	A GSM voice or data call is in progress. When the call terminates, H24 returns to the last operating state (Idle or Sleep).
CSD call or WCDMA/HSPA data	RESET_N signal is high. TXEN_N signal is toggling.	A GSM voice or data call is in progress. When the call terminates, H24 returns to the last operating state (Idle or Sleep).

Power Supply

The H24 power supply must be a single external DC voltage source of 3.3V to 4.2V. The power supply must be able to sustain the voltage level during a GSM transmit burst current surge, which may reach 2.0A.

The H24 interface connector has 8 contacts for the main power supply, as described in [Table 2-2](#). All these contacts must be used for proper operation.

Table 2-2: Power Supply Signals

Pin #	Signal Name	Description
1-4	GND	Main ground connection for H24 module.
5-8	VCC	DC supply input for H24 module. $V_{IN} = 3.3 \text{ V to } 4.2 \text{ V}$ $I_{MAX} = 2 \text{ A}$ during transmit bursts Maximum rise time: 8mS AC ripple: +/-3%

Important: Do not operate the H24 out of its electrical or environmental limits. Refer to the specifications chapter for details of these limits.

Important: The H24 does not incorporate a hard reset capability. The user should implement a power removal mechanism for hard resetting the unit when needed. This action will be performed with care as it could cause damage to the H24.

Power Supply Design

Special care must be taken when designing the power supply of the H24. The single external DC power source indirectly supplies all the digital and analog interfaces, but also directly supplies the RF power amplifier (PA). Therefore, any degradation in the power supply performance, due to losses, noises or transients, will directly affect the H24 performance.

The burst-mode operation of the GSM transmission and reception, draws instantaneous current surges from the power supply, which causes temporary voltage drops of the power supply level. The transmission bursts consume the most instantaneous current, and therefore cause the largest voltage drop. If the voltage drops are not minimized, the frequent voltage fluctuations may degrade the H24 performance.

Figure 2-4 illustrates the power supply behavior during GSM transmission.

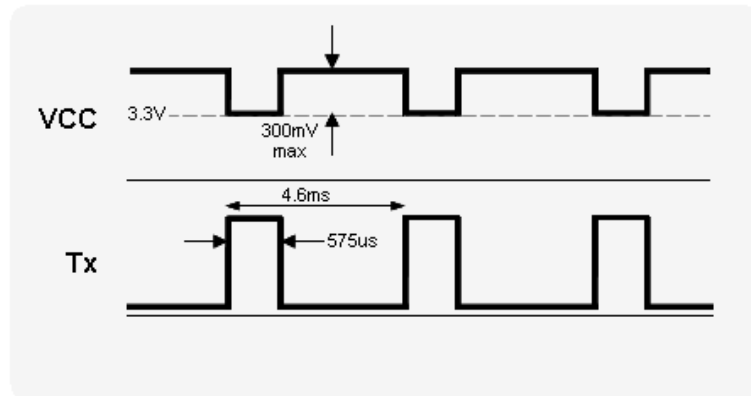

Figure 2-4: Transmission Power Drops

Note: 1 TX slot is shown.

It is recommended that the voltage drops during a transmit burst will not exceed 300mV, measured on the H24 interface connector. In any case, the H24 supply input must not drop below the minimum operating level during a transmit burst. Dropping below the minimum operating level may result in a low voltage detection, which will initiate an automatic power-off.

To minimize the losses and transients on the power supply lines, it is recommended to follow these guidelines:

- Use a 1000 uF, or greater, low ESR capacitor on the H24 supply inputs. The capacitor should be located as near to the H24 interface connector as possible.
- Use low impedance power source, cabling and board routing.
- Use cabling and routing as short as possible.
- Filter the H24 supply lines using filtering capacitors, as described in [Table 2-3](#).

Table 2-3: Recommended Power Supply Filtering

Capacitor	Usage	Description
1000 uF	GSM Transmit current surge	Minimizes power supply losses during transmit bursts- no more than 200mV. Use maximum possible value.
10 nF, 100 nF	Digital switching noise	Filters digital logic noises from clocks and data sources.
8.2 pF, 10 pF	1800/1900/2100/1700 MHz bands	Filters transmission EMI.
33 pF, 39 pF	850/900 MHz bands	Filters transmission EMI.

Current Consumption

The table below specify typical H24 current consumption ratings in various operating modes. The current ratings refer to the overall H24 current consumption over the VCC supply.

Note: H24 was tested at 25°C, voltage level was 4V.
Idle mode measurements were taken without USB cable connected.

Table 2-4: H24 Current Ratings

Parameter	Description	Conditions	Min	Typ	Max	Unit
I_{OFF}	RTC mode			40	50	μA
I_{IDLE}	Idle mode			22		mA
I_{SLEEP}	Low power mode	DRx	2	2.95		mA
			5	1.82		
$I_{GSM-RMS}$	GSM voice - 1 TX slot 1 Rx slot	GSM850 PCL	5	328		mA
			10	215		
			15	165		
			19	152		
		EGSM900 PCL	5	310		
			10	213		
			15	161		
			19	150		
		DCS1800 PCL	0	250		
			5	201		
			10	159		
			15	152		
		PCS1900 PCL	0	271		
			5	187		
			10	161		
			15	153		
$I_{GPRS-RMS}$	GPRS Class 12 - 4 TX slot 1 Rx slot	GSM850 PCL	5	577		mA
			10	456		
			15	265		
			19	217		
		EGSM900 PCL	5	611		
			10	485		
			15	278		
			19	222		
		DCS1800 PCL	0	401		
			5	322		
			10	237		
			15	210		
		PCS1900 PCL	0	451		
			5	354		
			10	247		
			15	213		

Table 2-4: H24 Current Ratings (Cont.)

Parameter	Description	Conditions	Min	Typ	Max	Unit
$I_{\text{EGPRS-RMS}}$	EGPRS Class 12 - 4 TX slot 1 Rx slot	GSM850 PCL	8		369	mA
			14		227	
			19		219	
		EGSM900 PCL	8		389	
			14		231	
			19		222	
		DCS1800 PCL	2		317	
			9		244	
			15		211	
		PCS1900 PCL	2		346	
			9		257	
			15		212	
$I_{\text{GSM-MAX}}$	Peak current During TX slot	GSM850 PCL	5		1873	mA
			10		853	
			15		438	
			19		331	
		GSM900 PCL	5		1667	
			10		886	
			15		459	
			19		335	
		DCS1800 PCL	0		1126	
			5		562	
			10		373	
			15		315	
PCS1900 PCL	0		1302			
	5		637			
	10		400			
	15		327			
$I_{\text{WCDMA-RMS}}$	WCDMA	WCDMA850	24dBm		512	mA
			0dBm		172	
			-24dBm		168	
			-50dBm		167	
		WCDMA1900	24dBm		537	
			0dBm		146	
			-24dBm		135	
			-50dBm		133	
		WCDMA2100	24dBm		608	
			0dBm		217	
			-24dBm		211	
			-50dBm		209	
		WCDMA1700	24dBm		TBD	
			0dBm		TBD	
			-24dBm		TBD	
			-50dBm		TBD	

Power On/Off Operation

The H24 power on and off process includes two primary phases, which are indicated at the interface connector by the hardware output signals RESET_N and CTS_N.

The RESET_N signal indicates whether H24 is powered on or off.

When this signal is enabled (low), H24 is powered-off. When it is disabled (high), H24 is powered-on.

The CTS_N signal complies with RS-232 standard. When this signal is high, the H24 serial interface is disabled. When it is low, the serial interface is enabled, and H24 is ready to communicate.

Turning the H24 On

When the H24 power supply is stable above the minimum operating level and H24 is powered off, only the internal RTC timer is active.

When H24 is turned on, by any of the methods described below, it will first perform an automatic internal system-test, during which basic functions are verified. The system-test duration is typically 3 seconds (Depends on network coverage). When the system-test has completed H24 resumes normal operation.

During the internal system-test process H24 may toggle several interface signals, which are visible to the application. These signals do not represent any valid state or data, and should be ignored by the customer application until the system-test has completed.

Power Supply Turn-on

When the H24 is powered for the first time, it is always switched on. In case the valid reason detected (IGN, ON_N activation) it will stay on, otherwise it will switch off.

The ON_N and IGN signals will be active and responding only after the power supply to the H24 is stable above the minimum operating level. Therefore, the ON_N and IGN signals must not be used for at least 100 milliseconds after applying power to H24.

Turning the H24 On Using ON_N

The ON_N input signal is set high by an internal pull-up resistor whenever a power supply is applied to H24. Therefore, it is recommended to operate this signal using an open collector/drain circuit connection.

Asserting the ON_N signal low for a minimum of 500 milliseconds (0.5 seconds) and a maximum of 1.5 seconds will cause the H24 to turn-on.

Asserting the ON_N signal low for more than 1.5 seconds may cause the H24 to interpret the signal as a power-off command, and turn off immediately after turning on.

Turning the H24 On Using IGN

The IGN input signal must be set low when not used. To turn on H24, this signal must be asserted high. The IGN signal must remain high for the duration of the H24 operation. H24 powers down when the IGN signal is returned to its low state.

Turning the H24 Off

There are several ways to turn the H24 off:

- Asserting the ON_N signal low for a minimum of 2 seconds.
- Setting the IGN signal low.
- Low power automatic shut down.
- AT command.
- Voltage exceeds 4.5V.
- Temperature at PMIC exceeds 125°C.

Turning the H24 Off Using ON_N

The ON_N signal is set high using an internal pull up resistor when power is applied to H24. Asserting the ON_N signal low for a minimum of 2 seconds will turn H24 off. This will initiate a normal power-off process, which includes disabling of all applications interfaces (UART, SIM card, audio, etc.) and closing the network connection.

Turning the H24 Off Using IGN

The IGN signal may be used to power off H24 only if it was also used to power it on. When the IGN signal is set low, H24 will turn off. This will initiate a normal power-off process, which includes disabling of all applications interfaces (UART, SIM card, audio, etc.) and closing the network connection.

The IGN signal will not power off H24 before 30 seconds have elapsed since H24 was powered-on. This delay mechanism is implemented to protect H24 from unexpected transients on the IGN line during power up, particularly when applying vehicle cranking waveforms.

Power Loss shut down

A low power shut down occurs when H24 senses the external power supply is below the minimal operating limit. The module will respond by powering down automatically without notice.

This form of power-down is not recommended for regular use since the unexpected power loss may result in loss of data.

Turning the H24 Off Using AT+MPWRDN

The AT+MPWRDN command initiates a H24 power down (even if the H24 was powered on by IGN). This command emulates the ON_N signal operation for power off.

Low Power Mode

The H24 incorporates an optional low power mode, called Sleep Mode, in which it operates in minimum functionality, and therefore draws significantly less current. During low power mode the H24 network connection is not lost. H24 continues to monitor the GSM network constantly for any incoming calls or data.

During low power mode, most of the H24 interface signals are inactive and are kept in their previous state, prior to activating low power mode. To save power, the H24 internal Main clock and some of its circuits are shut down, and therefore serial communications is limited.

Activating Low Power Mode

UART:

By default, the H24 powers on in Idle mode. In this mode the H24 interfaces and features are functional and the module is fully active.

Low power mode is controlled by the AT+MSLEEP & ATS24 commands.

The command AT+MSLEEP=1 enable Sleep Mode (AT+MSLEEP=0 disable Sleep Mode).

The value of S24 command determines the inactive state duration required by H24, in seconds, after which H24 will enter sleep mode.

For example:

ATS24 = 1 activates low power mode after 1 second of UART inactivity.

ATS24 = 5 activates low power mode after 5 seconds of UART inactivity.

Note: ATS24=0 will not disable sleep mode at H24.

AT+MSLEEP = 1 Enable low power mode.

AT+MSLEEP = 0 Disable low power mode (default).

Important: H24 will not enter low power mode in any case when there is data present on the serial interface. Also when any network (GSM/UMTS) activity (e.g. incoming voice call, data session) or an internal system task is running. Only when processing of any external or internal system task has completed, if AT+MSLEEP=1 and H24 UART is inactive for the duration of ATS24, H24 will enter low power mode.

USB:

Any transaction to the USB will wake up the H24 provided the user USB stack supports suspend/resume mechanism. In case such mechanism is not supported the user will not be able set the H24 at sleep mode.

In case of resume event the SW will be responsible to all the needed configurations (endpoints etc.) to maintain the link. In case the host USB protocols stack doesn't support resume suspend mechanism the USB module in the H24 will not go to sleep hence the entire H24 will remain active as long as the USB cable is connected.

Remote wake up is supported.

CTS signal conforms RS-232 standard at this mode.

Serial Interface During Low Power Mode

During low power mode the H24 serial interfaces are disabled. This is indicated by the CTS_N signal high state (if hardware flow control is set by AT+IFC=2, 2 (or AT&K4) and CTS control is set by AT+MSCTS=1 command).

The H24 wakes up periodically from low power mode to listen to paging channel of the GSM/WCDMA networks for any incoming calls or data. After this short paging is completed, H24 returns to low power mode. During this short awake period, the serial interfaces are enabled and communications with the module is possible (if both AT+IFC=2, 2 (or AT&K4) and AT+MSCTS=1 commands are in use).

The CTS_N signal is alternately enabled and disabled synchronously with the network paging cycle. CTS_N is enabled whenever H24 awakes to page the network. This indicates the H24 serial interfaces are active (see [Figure 2-5](#)).

When using AT+IFC=2, 2 the Heaper Terminal should be set to flow control - HW.

When using AT+IFC=0, 0 the Heaper Terminal should be set to flow control - None.

Need to disconnect and connect to Heaper terminal for the new setup to be active.

RS232 cable hot swap is supported and insert cable will wake up the H24.

WAKEUP_IN line pin 16 (on 70 pin connector) should override any sleep condition and will prevent H24 from enter sleep mode.

In case user is working with UART and enables HW flow control, it is advised that the user will plan his system to wake up H24 also using the WAKEUP_IN HW line.

If the following conditions become true the user will be able to wake H24 only through WAKEUP_IN line (or just return to work with folow control = None); and will not be able to wake H24 through RX activity (sending data):

- Sleep mode over UART enabled
- UART HW flow control enabled
- Airplane mode enabled (AT+CFUN=0 or AT+CFUN=4).

In this case there is no DRX and CTS is not rising.

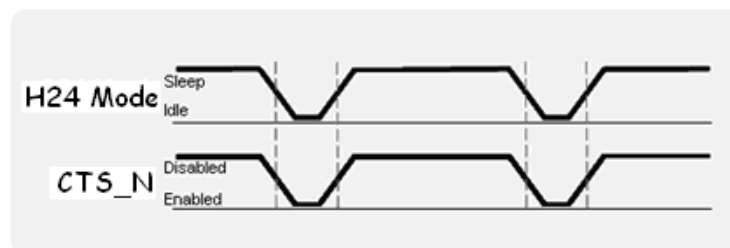

Figure 2-5: CTS Signal During Sleep Mode

The periodical enabling and disabling of the CTS_N signal during low power mode can be controlled by the AT+MSCTS command.

Setting AT+MSCTS=0 permanently disables the serial interface during low power mode, even during a network page by H24. The CTS_N signal is disabled, and therefore the serial interfaces are blocked.

Terminating Low Power Mode

Terminating the low power mode, or wake-up, is defined as the transition of the H24 operating state from Sleep mode to Idle mode. There are several ways (using UART CTS_N signal, WKUPI_N line or UART RX line interrupt) to wake-up H24 from low power mode as described below.

Important: During power saving mode the H24 internal clocks and circuits are disabled, in order to minimize power consumption. When terminating the power saving mode, and switching to Idle mode, H24 requires a minimal delay time to reactivate and stabilize its internal circuits before it can respond to application data. This delay is typically of 100 milliseconds, and is also indicated by the CTS_N signal inactive (high) state. The delay guarantees that data on the serial interface is not lost or misinterpreted.

Temporary Termination of Low Power Mode

The WKUPI_N signal is an active low input that is set high by default. By asserting this signal low the application can wake-up H24 from low power mode and switch to idle mode.

Low power mode may be terminated temporarily by several sources, some of which are user initiated and others are initiated by the system.

Using the WKUPI_N signal to wake UART from Sleep Mode

The WKUPI_N signal is an active low input, that is set high by default. By asserting this signal low the application can wake-up H24 from low power mode and switch to Idle mode.

H24 will remain in idle mode, awake and fully active, as long as WKUPI_N signal remains low. When this signal is disabled and set high again, H24 will return to Sleep mode automatically, according to the ATS24 settings.

The WKUPI_N signal is the **recommended** method to temporarily wake-up H24 from low power mode. It provides the application full control of the H24 operating mode and guarantees that data on the serial interface will not be lost or misinterpreted.

The WKUPI_N signal can be used to wake up H24 from low power mode. If the serial interface has been controlled by the AT+IFC=1,1 (or AT&K4) command, the application can work in Hardware Flow Control accumulate the data in its buffer and send it to the module when the CTS is Enabled. (Note: this method of operation works without using AT+MSCTS=0 command).

Incoming Network Data

During low power mode, H24 continues monitoring the network (GSM or UMTS) for any incoming data, message or voice calls.

When H24 receives an indication from the network that an incoming voice call, message or data is available, it automatically wakes up from low power mode to alert the application. When H24 has completed to process all the tasks related to the incoming data, it will automatically return to low power mode according to the ATS24 settings.

Depending on the type of network indication and the application settings, H24 may operate in several methods, which are configurable by AT commands, to alert the application of the incoming data:

- Enable the WKUPO_N signal to wake-up the application from low power by setting AT_{S100} to value bigger than zero. AT_{S102} can be 0 but is 30ms by default for example AT_{S102}=30 will start WKUPO_N signal 30 millisecond before data send out from UART to Host.
- Send data to the application over the serial interface.
- Enable the serial interface's Ring Indicator (RI_N) signal.

Data on the Serial interface

While H24 is temporarily awake in Idle mode, data may be transmitted on the serial interface. In case data is being transmitted in any direction, H24 will not return to low power mode. This is regardless of the original wake-up reason or source. H24 will remain awake while data is transferred.

Only when the serial interface transfer is completed and the data has been processed, H24 will return to low power mode automatically, according to the AT_{S24} settings (see [Figure 2-6](#)).

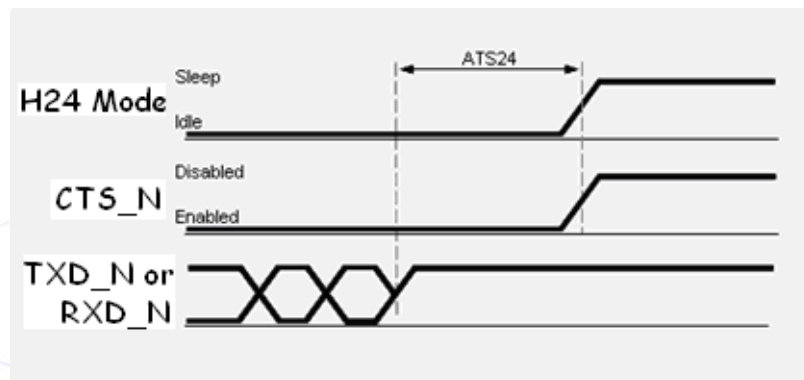

Figure 2-6: Serial Interface Data

UART and USB Exiting of Low Power Mode

Enable/Disable Low Power Mode

The H24 low power mode is enabled and disabled by the AT+MSLEEP command.

To permanently terminate the H24 low power mode, the +MSLEEP=0 command must be used. H24 will not return to low power mode until an AT+MSLEEP=1 command is set again.

This command can be sent only when the serial interface is active.

UART Exiting of Low Power Mode

In case the serial interface is disabled, Hardware Flow control is OFF and WKUP_I is not used, it must first be activated before sending this command. To reactivate the serial interface, a temporary termination of the low power mode is required, by sending AT command that will catch by the RX line interrupt service routine and will use to wake up the module (The execution of the first command after exit Sleep Mode by RX interrupt is not guaranteed).

USB Exiting of Low Power Mode

Handled by suspend/resume mechanism.

Real Time Clock

H24 incorporates a Real Time Clock (RTC) mechanism that performs time keeping. The RTC subsystem is embedded in the PMIC and operates in all of the H24 operating modes (Off, Idle, Sleep), as long as power is supplied above the minimum operating level.

The H24 time and date can be set using the following methods:

- Automatically retrieved from the GSM network.
In case H24 is operated in a GSM network that supports automatic time zone updating, it will update the RTC with the local time and date upon connection to the network. The RTC will continue to keep the time from that point.
- Using the AT+CCLK command.
Setting the time and date manually by this AT commands overrides the automatic network update.
Once the time and date are manually updated, the RTC timer will keep the time and date synchronized regardless of the H24 operating state.

When the power supply is disconnected from H24, the RTC timer will reset and the current time and date will be lost. On the next H24 power-up the time and date will need to be set again automatically or manually.

Nevertheless, there is ability to keep the RTC working while main power supply is off.

This can be done by supplying the RTC an external power of 3V to a dedicated pin in the microprocessor.

This dedicated pin is called Vcoin.

When the main power supply is off and Vcoin is active, the RTC is still working.

When power supply is off, no Vcoin applied, the RTC will work only for 2 sec, and will turn "off".

Serial Interfaces

H24 includes three completely independent serial communications interfaces, which may be used by the application for several purposes.

Primary UART (UART1)

The H24 primary UART is a standard 8-signal bus. The primary UART is used for all the communications with H24 - AT commands interface, GPRS/EGPRS data and CSD data, programming and software upgrades.

The UART signals are active low CMOS level signals. For standard RS232 communications with a PC, an external transceiver is required.

H24 is defined as a DCE device, and the user application is defined as the DTE device. These definitions apply for the UART signals naming conventions, and the direction of data flow, as described in [Figure 2-7](#).

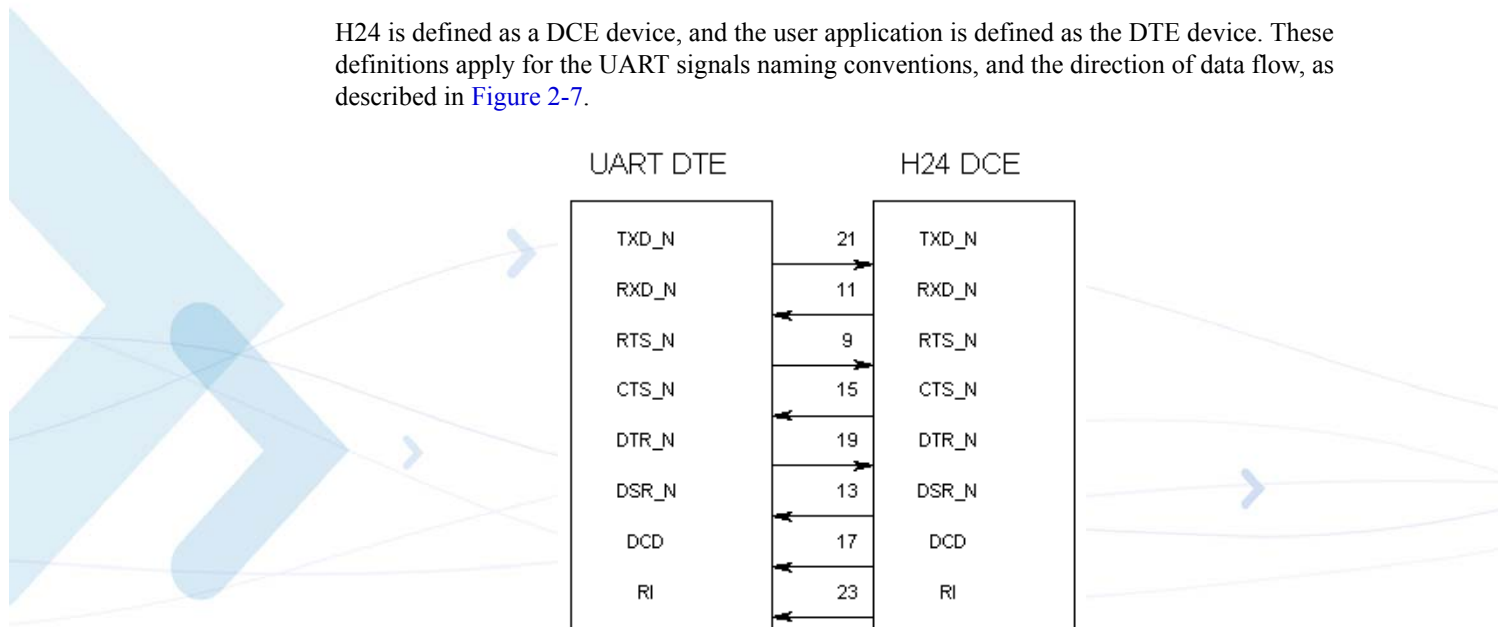

Figure 2-7: UART1 Interface Signals

The H24 primary UART supports maximum data rate of up to 4 Mbps interface and up to 230 kbps for data services using the UART1 interface.

All flow control handshakes are supported: hardware, software, or none.

Parity bit and Stop bit definitions are also supported.

The UART default port configuration is 8 data bits, 1 stop bit and no parity, with hardware flow control.

USB Interface

H24 incorporates a standard Universal Serial Bus (USB) interface.

The H24 USB electrical interface and protocol conform to the USB 2.0 high-speed specifications. H24 is defined as a USB device on the USB bus and does not support hub or host functionality.

USB may be used for standard communications with H24, as done through the UART interface. The USB interface signals are shown in [Figure 2-8](#).

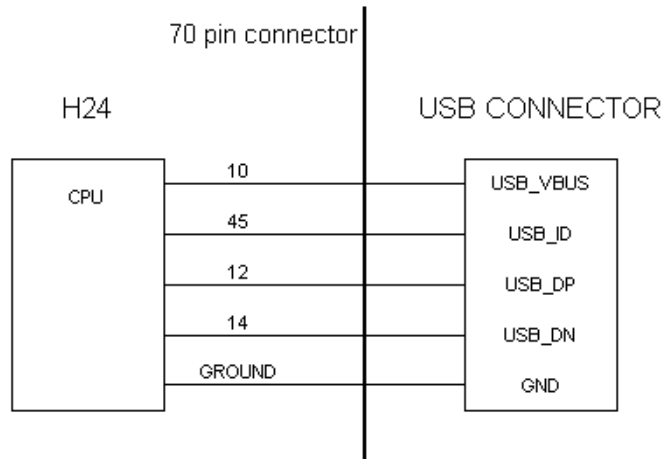

Figure 2-8: USB Interface Signals

UID determines the USB mode configuration: Host or Client (Client mode is supported).

Note: Do not connect USB_ID pin (pin 45).

Important: When laying out USB signals: Run HS_D_P/M as diff pair with equal length , to maintain 100-Ohms diff/50-Ohms single-ended.

SIM Interface

The H24 incorporates a SIM interface, which conforms to the GSM 11.11 and GSM 11.12 standards, that are based on the ISO/IEC 7816 standard. These standards define the electrical, signaling and protocol specifications of a GSM SIM card.

H24 does not incorporate an on-board SIM card tray for SIM placement. The SIM must be located on the user application board, external to the H24. The H24 SIM interface includes all the necessary signals, which are routed to the interface connector, for a direct and complete connection to an external SIM.

H24 supports dynamic detection of the SIM card, through a dedicated SIM detection signal. H24 will detect a SIM card insertion or removal upon power up or during operation by the transitions on the SIM_PD_N signal.

Some of the H24 models incorporate eSIM (embedded SIM). Refer to [“Embedded SIM” on page 28](#).

External SIM Connection

[Table 2-5](#) details the SIM interface signals.

Table 2-5: SIM Interface Signals

Connected to 70 pin	H24	Interruptible
44	SIM_RST_N	N
46	SIM_CLK	N
48	SIM_VCC	N
50	SIM_PD_N	Y
52	SIM_DIO	N

SIM Design Guidelines

The SIM interface and signals design is extremely important for proper operation of H24 and the SIM card. There are several design guidelines that must be followed to achieve a robust and stable design that meets the required standards and regulations.

- Using the SIM detection signal, SIM_PD_N, is mandatory in case the SIM card is accessible to the user and may be removed during H24 operation. To avoid any damage to the SIM or H24, the SIM interface signals must be deactivated before the SIM card contacts are mechanically removed from the SIM tray contacts. Therefore, the SIM_PD_N detection signal must be disabled before the SIM is removed from its tray.
- The SIM should be located, and its signals should be routed, away from any possible EMI sources, such as the RF antenna and digital switching signals.
- The SIM interface signals length should not exceed 100 mm between the H24 interface connector and the SIM tray. This is to meet with EMC regulations and improve signal integrity.

- To avoid crosstalk between the SIM clock and data signals (SIM_CLK and SIM_DIO), it is recommended to rout them separately on the application board, and preferably isolated by a surrounding ground plane.
- The SIM card signals should be protected from ESD using very low capacitance protective elements (zener diodes, etc.).
- The H24 interface does not support SIM programming through the VPP signal. This signal should not be connected to H24.
- SIM voltage level will not drop below 2.7V (1.6V for 1.8V SIM card) during hot insertion.
- It is recommended to add series termination at signals SIM_CLK (100 Ohm) and the SIM_DIO (56 Ohm) and bypass SIM_VCC with a 100nF cap.

Embedded SIM

The H24 newest feature is incorporating an Embedded SIM inside (depending on H24 model).

Embedded SIM (e.g. eSIM or chip SIM), is a secured micro controller IC, with the same pinout interface, and the same operation as an external SIM card.

The eSIM main advantage is its robustness, making it an ideal solution for M2M applications.

Since an eSIM is actually an IC soldered on the H24, it can withstand wider temperature range than a regular external SIM card that is usually made of plastic, and gets twisted and bowed at high temperature, causing disconnection inside the SIM tray.

For the same reason, the eSIM is more durable to vibration than a regular external SIM card. Hard vibration on an application with a SIM card socket may result in with an intermitted connection between the SIM card socket and the SIM card.

Two signals are associated with the eSIM:

- SIM_PD_N: (pin 50) This signal must be set low for acknowledge the H24 that eSIM is connected.
- Chip SIM reset: (pin 56) This pin is dedicated for resetting the eSIM. In case that the eSIM is incorporated, short circuit this pin to pin 44 (SIM_RST_N).

Audio Interface

The H24 audio interface supports several audio devices and operating modes.

The audio interface's operating modes, active devices, amplification levels and speech processing algorithms are fully controlled by the host application, through advanced programming options and a versatile AT commands set.

The H24 supports the following audio devices:

- Two single-ended/ Differential and mono analog microphone inputs for use in a variety of modes.
- Differential mono analog speaker output.
- Differential mono analog alert output. (Amplified to 1W)
- Single-ended mono analog headset output.
- A digital serial interface using PCM coding.

All the above analog audio paths with the interface to the 70 pin connector are shown in [Figure 2-9](#).

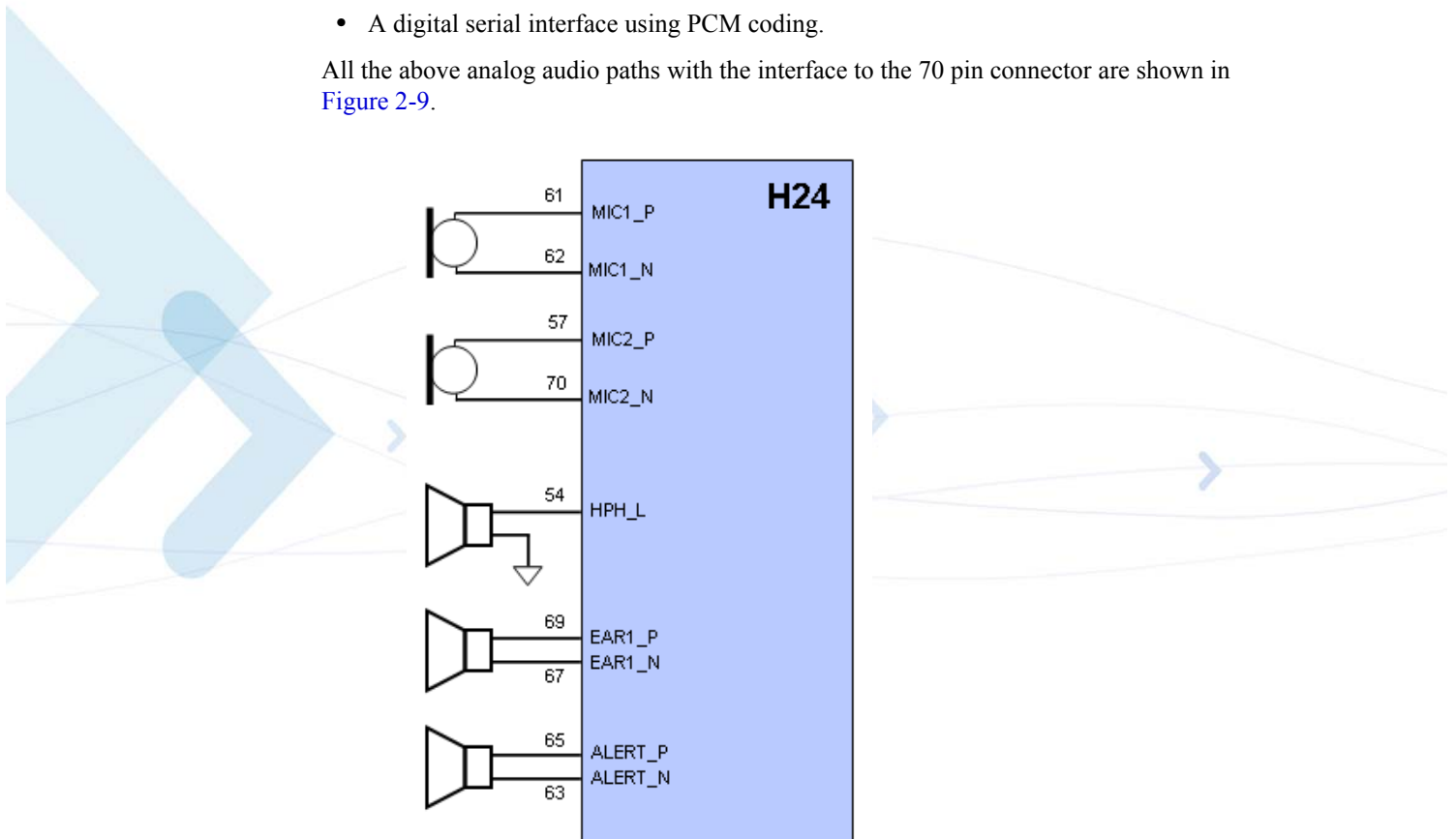

Figure 2-9: H24 Audio Interface

Handset Interface

Typical handset interfaces are shown in [Figure 2-10](#). The earphone output pins are connected directly to the handset's earphone with 2 bypass capacitors connected to ground. The capacitance is selected de-pending on the design, typically less than 100 pF.

The output power for the differential EAR1 output is typically 70 mW for a full-scale +3 dBm0 sine wave into a 32Ω speaker.

Both microphone pins require 2.2 k bias resistors and 0.1μF AC-coupling capacitors.

The positive microphone terminal is connected to the μC MICBIAS pin through one of the 2.2 kΩ resistors; this 1.8 V output provides 1 mA of bias current for the Microphone.

MICBIAS supports multiple microphones simultaneously up to 1 mA.

In case the user connect single-ended mic, he must connect it to pin 61 and short circuit pin 62 to ground.

For gain levels, please refer to H24 AT Commands manual - 6802986C37.

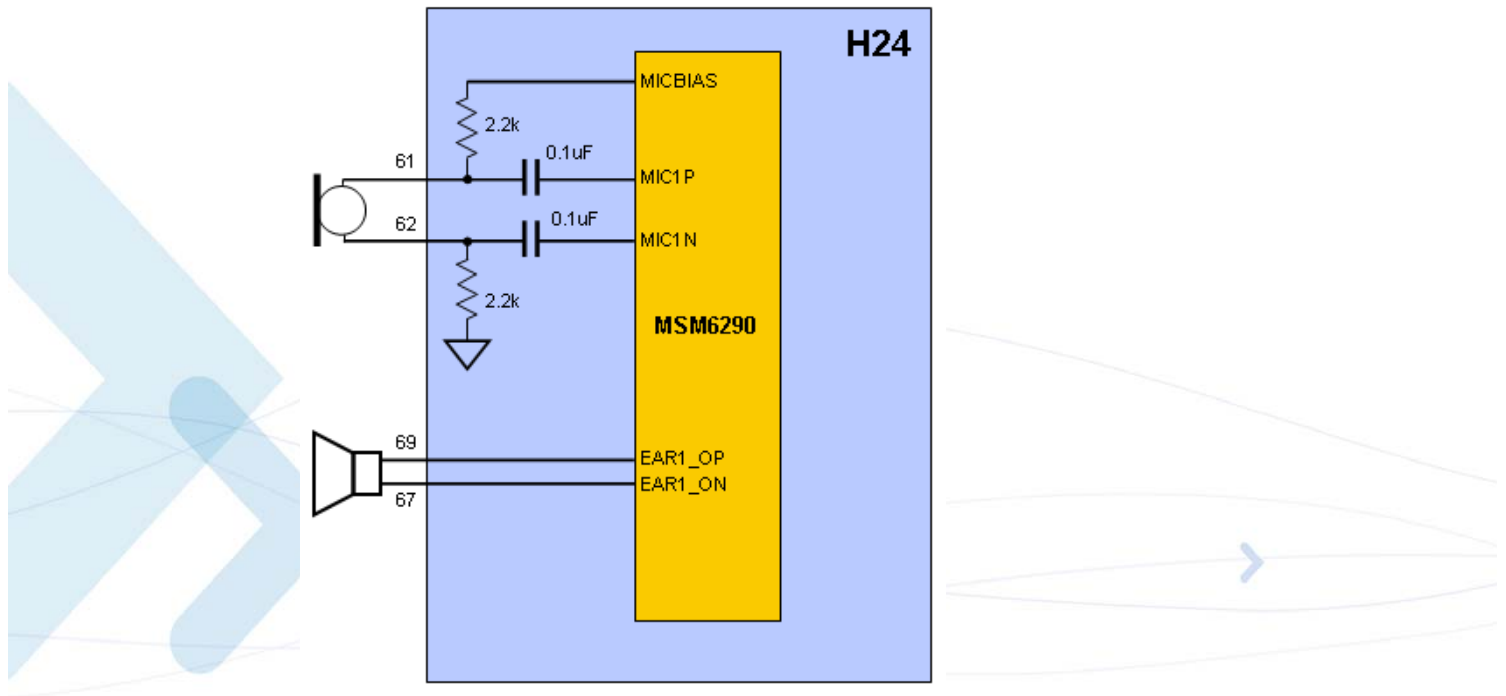

Figure 2-10: Handset Interface

Headset Interface

The most basic headset configuration is shown in Figure 2-11. This configuration uses an AC-coupled mono earphone interface and a standard single-ended microphone interface.

The output power for the single-ended HPH_L/HPH_R output is typically 21.6 mW per side for a full-scale +3 dBm0 sine wave into a 15Ω speaker.

Few alternative earphone configurations are given in the following paragraphs. If the load capacitance is greater than 100 pF due to earphones with different capacitive load used, a RC shunt network (0.22 μ F and 22 Ω) is recommended to prevent oscillations as shown in [Figure 2-11](#).

Note: In case a differential mic is used, the negative node should be connected to pin 70.

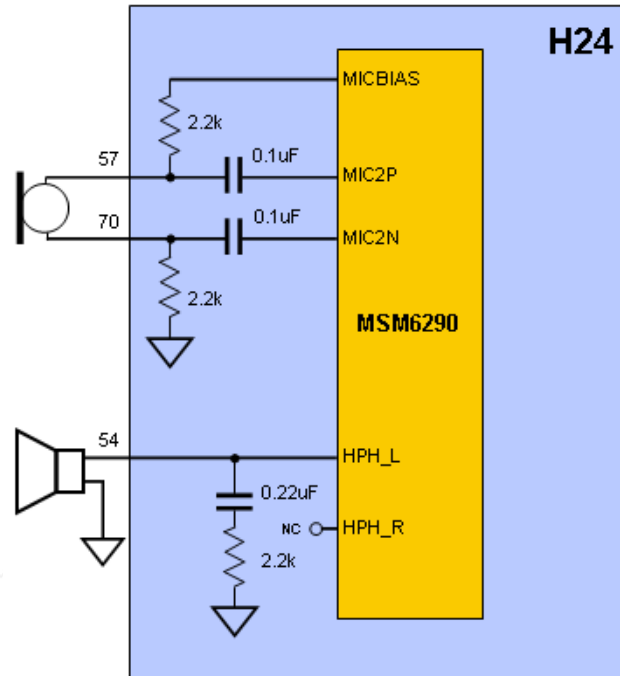

Figure 2-11: Headset Interface

Interface to an External Speaker Amplifier

The power management device can also be used as a speaker amplifier. The power management speaker driver output power is rated at 500 mW and can be adjust up to 1W. To use this feature as an amplifier of an audio output, be sure to set the appropriate speaker driver analog and digital gains, and set the analog high-pass filter corner at the resonant frequency of the far-field speaker transducer (see [Figure 2-12](#)).

For gain levels, please refer to H24 AT Commands manual - 6802986C37.

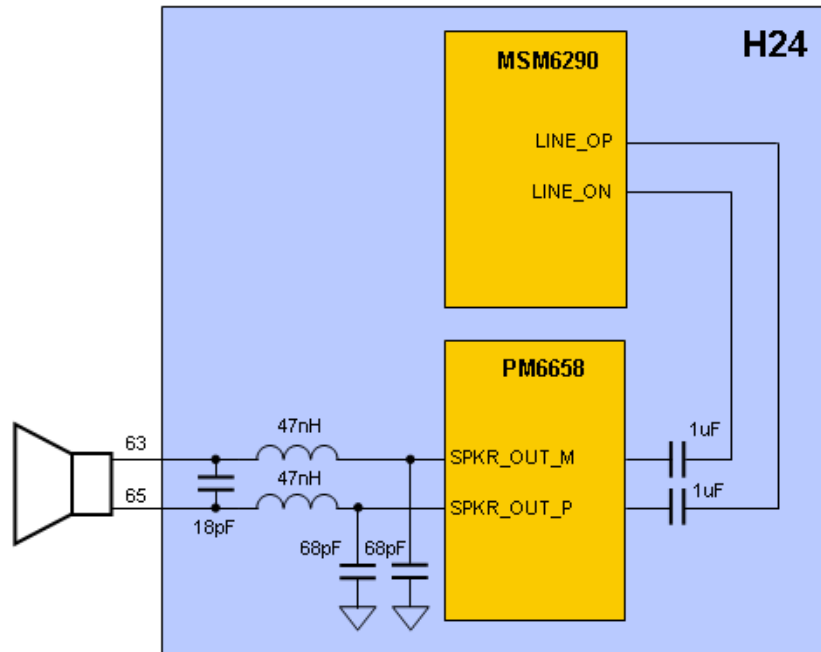

Figure 2-12: External Speaker

Audio Design

The audio quality delivered by H24 is highly affected by the application audio design, particularly when using the analog audio interface. Therefore, special care must be taken when designing the H24 audio interface. Improper design and implementation of the audio interface will result in poor audio quality.

Poor audio quality is a result of electrical interferences, or noises, from circuits surrounding the audio interface. There are several possible sources for the audio noise:

- Transients and losses on the power supply
- EMI from antenna radiations
- Digital logic switching noise

Most of the audio noise originates from the GSM transmit burst current surges (217 Hz TDMA buzz), which appear on the main power supply lines and antenna, but also indirectly penetrate the internal application's supplies and signals. The noises are transferred into the H24's audio circuits through the microphone input signals and then are amplified by the H24's internal audio amplifiers.

To minimize the audio noise and improve the audio performance the microphone and speaker signals must be designed with sufficient protection from surrounding noises.

The following guidelines should be followed to achieve best audio performance:

- Reference the microphone input circuits to the H24 AGND interface signal.
- If using single-ended audio outputs, they should be referenced to the H24 AGND interface signal.

- Keep the audio circuits away from the antenna.
- Use RF filtering capacitors on the audio signals, as described in [Table 2-3](#).
- The audio signals should not be routed adjacent to digital signals.
- Isolate the audio signals by a surrounding ground plane or shields.
- Filter internal supplies and signals that may indirectly affect the audio circuits, from noises and voltage drops.

Analog Ground

The H24 interface incorporates a dedicated analog ground contact, AGND pin 59, which is internally connected to the H24's ground. The AGND signal is intended to provide a separate ground connection for the application's external audio devices and circuits.

This signal provides an isolated ground connection directly from H24, which is separated from the noisy digital ground of the application. It is recommended to connect this signal to analog audio devices and circuits used by the application. Using a separate analog ground minimizes audio noises and improves the audio circuit's immunity from external interferences.

Digital Audio Interface

The H24 digital audio interface is a serial Pulse Code Modulation (PCM) bus, which uses linear 2's complement coding. H24 is the PCM bus master, supplying the clock and sync signals to the application.

The H24 digital interface is a 4 signal PCM bus, which includes a bit clock output signal for the bus timing, a frame sync output signal for audio sampling timing, and serial data input and output signals.

Important: The PCM bus signals are shared internally by the analog audio interface and the digital audio interface. Therefore, when using the analog audio interface the PCM bus signals must be tri-stated or disconnected at the interface connector.

The digital audio interface supports 4 types of audio data formats, which define the PCM bus configuration and data rates:

- Voice band audio - Intended for speech during voice calls and for mono rings and alerts.
- Stereo audio - Includes 3 audio formats that support high quality stereo ring tones and alerts.

Voiceband Audio

This digital voice audio format is used for speech during voice calls and for mono rings and alerts.

The PCM bus signal's configuration for voiceband audio is:

- PCM_CLK - 2048 kHz serial clock
- PCM_FS - 8 kHz bit-wide frame-sync
- PCM_DOUT - 13-bit linear audio data output
- PCM_DIN - 13-bit linear audio data input

The analog audio is sampled at an 8 kHz rate and converted to linear 13-bit serial PCM audio data. The serial data is transferred on the PCM bus in 16-bit word format, which includes 13 sampled data bits, and 3 added zero value bits.

The 16-bit serial data is transferred in both directions after each sync signal's falling edge. The sync signal pulse duration is one clock period, after which the serial data is transferred in both directions for 16 consecutive clock periods.

Following the 16-bit data transfer, the serial input and output data signals inactivate until the next sync pulse, which occurs every 125 μ S (8 kHz). It is recommended the serial data signals will be High-Z during the inactive period.

Important: In digital audio mode the input and output gains cannot be controlled by AT commands.

Figure 2-13 illustrates the PCM bus format of the voiceband audio configuration.

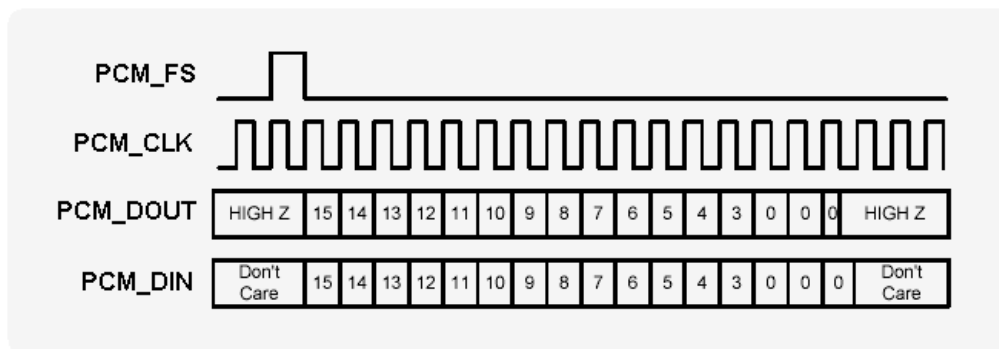

Figure 2-13: Voiceband Mode PCM Bus Coding Format

Controls and Indicators Interface

The H24 incorporates several interface signals for controlling and monitoring the module's operation. The following paragraphs describes these signals and their operation.

Table 2-6 gives a description of the controls and indicators signals.

Table 2-6: Controls and Indicators

Connector Pin	Signal Name	Description
25	RESET_N	H24 system reset output indicator. When high, H24 is operating.
27	VREF	2.6V regulated output. Supplies external circuits up to 300mA.
16	WKUPO_N	Host application wake-up signal indicator.
49	Network status indicator	Network status indicator. (GPRS/GSM/WCDMA)
39	TXEN_N	Transmission burst indication.
28, 30, 32, 34, 36, 38, 40, 42	GPIO 1-8	General purpose IO signals for customer use.

Reset

The RESET_N output signal indicates the H24's operating status. This signal is set high after power up, when H24 is operating. It is set low when H24 is powered off.

When the RESET_N signal is low, the H24 interface signals are disabled and do not represent any valid data or state. Furthermore, any input signals connected to the H24 interface must be disabled (tri-state) or set low when RESET_N is low.

VREF Reference Regulator

The H24 incorporates a regulated voltage output, VREF. The regulator provides a 2.6V output for use by the customer application. This regulator can source up to 300 mA of current to power any external digital circuits.

Important: The VREF regulator is powered from the H24's main power supply, and therefore any current sourced through this regulator originates from the H24 VCC supply. The overall VCC current consumed by H24 is directly affected by the VREF operation. The H24 current consumption rises with respect to the current sourced through VREF.

The VREF regulator incorporates 3 operating modes that are controlled by the AT+MVREF command. These modes define the regulator operating state relative to the H24's operating mode.

OFF Mode

In this mode the VREF regulator is disabled and its output drops to 0V, regardless of the H24 operating state.

Sleep Mode

The 300 mA rated linear regulator offers a low power mode to reduce its quiescent current during the module's sleep mode. This mode uses reduced current in the feedback loop, causing degraded performance (PSRR, output current capability, etc.). In fact, if the load increases beyond 1 mA the output voltage can go out of specification. This mode should only be used when the module is in its sleep mode.

Active Mode

In this mode the VREF regulator is always fully active while H24 is operating, regardless of the H24 operating mode.

Table 2-7 gives the VREF specifications.

Table 2-7: VREF Specifications

Parameter	Conditions	Min	Typ	Max	Unit
V_{OUT}		-3%	2.6	+3%	V
I_{OUT}				300	mA
Load regulation				0.65	%
Line regulation				0.2	%/V
PSRR			40		dB

Wakeup Out

Some applications incorporate their own power saving mode, in which they operate with minimal functionality, including disabling of interfaces and serial communications.

The wakeup-out (WKUPO_N) signal is an active low output, which is designed to support a low power mode feature in the host application. This signal is used by H24 to indicate that it requires to communicate with the host application through the serial interface, due to an incoming call or data, or an unsolicited event. Applications that incorporate a low power mode should use this signal as an indication to switch from low power mode to normal operation, and activate the serial interface.

The wakeup-out mechanism, using the WKUPO_N signal, is controlled by 2 AT commands (see Figure 2-14):

- AT5102 - Defines the delay time in milliseconds that H24 will wait, after asserting the WKUPO_N signal low, before sending data on the serial interface. This delay is required to allow the application enough time to reactivate from low power mode and switch to normal

mode.

If $ATS102=0$, which is the default value, the WKUPO_N signal and mechanism is disabled. In case the serial interface incorporates hardware flow control signals, the data will be sent according to their state, after the $ATS102$ delay time has expired.

- $ATS100$ - Defines the application minimal wakeup duration, in seconds, for a single wakeup event. This time definition is required to avoid frequent unnecessary wakeup events and consequent $ATS102$ delays.

The application may return to low power mode after the serial interface has been inactive for the duration set by $ATS100$. This duration is measured from the last data sent or received on the serial interface.

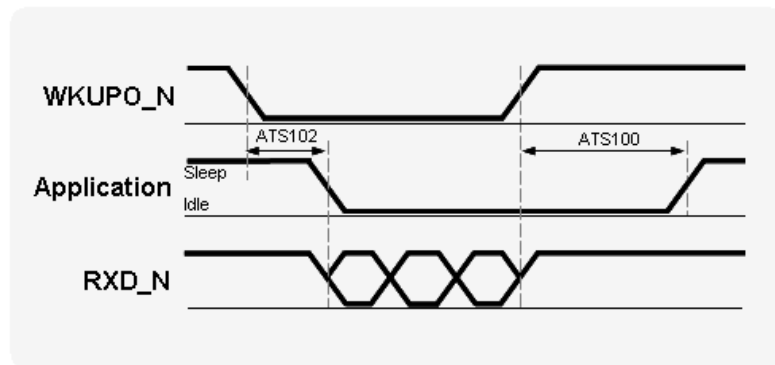

Figure 2-14: WKUPO_N Operation

The following guidelines apply to the wakeup-out mechanism:

- H24 will set the WKUPO_N signal low to indicate that it has data to send through the serial interface.
- H24 will start sending the data to the application after the delay defined by $ATS102$.
- The WKUPO_N signal will remain low while data is being sent to the host application.
- The host application should keep its serial interface active, and not switch to low power mode, while the WKUPO_N signal is low.
- H24 will set the WKUPO_N signal high when it has completed sending the data.
- The application serial interface must stay active, and not switch to low power mode, for the duration set by $ATS100$, after WKUPO_N is set high.
- H24 will not set the WKUPO_N signal low if it needs to send additional data during the $ATS100$ delay time.
- The application may switch to low power mode after the WKUPO_N signal is set high and the serial interface has been inactive for the duration set by $ATS100$.

Network Connection Detection

The network connection output signal (Pin 49) indicates the network (GPRS/EGPRS or WCDMA/HSPA) connection status. When H24 is connected to a network, this signal is enabled. When H24 is not connected to the GPRS/EGPRS or WCDMA/HSPA network this signal is disabled. This pin (Pin 49) is enabled by the command `AT+MCWAKE`.

Transmission Indicator

The TXEN_N output signal indicates when H24 is transmitting over the GSM or CDMA network. This signal follows the H24 GSM transmit bursts. This signal is set low during transmission burst, and set high when no transmission is in progress.

Figure 2-15 shows the TXEN_N operation.

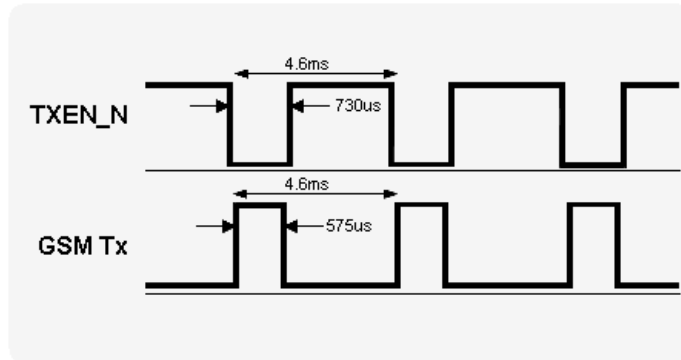

Figure 2-15: TXEN_N Operation

General Purpose I/O

The H24 incorporates 8 general purpose IO signals for the user application. Each GPIO signal may be configured and controlled by AT command. These signals may be used to control or set external application circuits, or to receive indications from the external application.

Antenna Interface

The H24 antenna connector is the RF interface to the GSM/WCDMA network.

The antenna interface is terminated by an MMCX connector type, which is 50Ω impedance matched at the relevant GSM frequencies.

The antenna or antenna application must be installed properly to achieve best performance.

Table 2-8 gives the antenna interface specifications.

Table 2-8: Antenna Interface Specifications

Parameter	Conditions	Specifications
GSM 850	TX	824 - 849 MHz
	RX	869 - 894 MHz
GSM 900	TX	880 - 915 MHz
	RX	925 - 960 MHz
DCS 1800	TX	1710 - 1785 MHz
	RX	1805 - 1880 MHz
PCS 1900	TX	1850 - 1910 MHz
	RX	1930 - 1990 MHz
Gain		For antenna gain please refer to “Antenna Installation” .
Impedance		50Ω
VSWR		Less than: 2.5:1
WCDMA B1 2100	TX	1920-1980 MHz
	RX	2110 - 2170 MHz
WCDMA B2 1900	TX	1850-1910 MHz
	RX	1930-1990 MHz
WCDMA B5 850	TX	824 - 849 MHz
	RX	869 - 894 MHz
WCDMA B4 1700	TX	1710 - 1755 MHz
	RX	2110 - 2155 MHz

It is the Integrator's responsibility to design the antenna or antenna assembly used with the H24. This will highly affect the RF performance of the H24 (dropped calls, battery consumption etc.). The following guidelines should be followed:

- Make sure that the antenna or antenna assembly matches the Antenna Interface Specifications.
- Use low loss RF cable and connectors keeping cable runs to a minimum.



Chapter 3: Electrical and Environmental Specifications

Absolute Maximum Ratings

Table 3-1 gives the maximum electrical characteristics of the H24 interface signals.

Caution: Exceeding the values may result in permanent damage to the module.

Table 3-1: Maximum Ratings

Parameter	Conditions	Min	Max	Unit
VCC Supply		-0.2	4.2	V
Digital Input Signals (Except for IGN, VBUS, USB_DP, USB_DN)	H24 powered on	-0.2	2.9	V
Analog Input Signals (Audio, A/D inter- faces)	H24 powered on	-0.2	2.9	V
All Input Signals (Except for IGN, VBUS, USB_DP, USB_DN)	H24 powered off	-0.2	0.2	V
IGN signal		-0.2	16	V
VBUS signal		-0.2	5.25	V
USB_DP, USB_DN		-0.2	3.6	V

Caution: It is not recommended to connect the ignition pin directly to the car's ignition wire without adequate protection.

Environmental Specifications

Table 3-2 gives the environmental operating conditions of the H24 module.

Caution: Exceeding the values may result in permanent damage to the module.

Table 3-2: Environmental Ratings

Parameter	Conditions	Min	Max	Unit
Ambient Operating Temperature		-30	65	°C
	Restricted operation (For more details please contact M2M.Customer-Care@motorola.com)	-30	85	°C
Storage Temperature		-40	85	°C
ESD	At antenna connector			KV
	Contact		± 8	
	Air		± 15	
	At interface connector		± 1	

Application Interface Specifications

Table 3-3 summarizes the DC electrical specifications of the application interface connector signals.

Important: Interface signals that are not used by the customer application must be left unconnected. H24 incorporates the necessary internal circuitry to keep unconnected signal in their default state. Do not connect any components to, or apply any voltage on, signals that are not used by the application.

Important: Signals that are defined as "Do Not Use", or DNU, must remain externally unconnected in any case. These signals are reserved for future use.

The following table gives a brief description of the 70 pins connector for quick integration.

GND	1	2	GND
GND	3	4	GND
VCC	5	6	VCC
VCC	7	8	VCC
RTS_N	9	10	USB_VBUS
RXD_N	11	12	USB_DP
DSR_N	13	14	USB_DN
CTS_N	15	16	WKUPI_N
DCD_N	17	18	PCM_DIN
DTR_N	19	20	PCM_DOUT
TXD_N	21	22	PCM_CLK
RI_N	23	24	PCM_FS
RESET_N	25	26	WKUPO_N
VREF	27	28	GPIO1
RXD2	29	30	GPIO2
TXD2	31	32	GPIO3
RTS2	33	34	GPIO4
CTS2	35	36	GPIO5
ADC1	37	38	GPIO6
TXEN_N	39	40	GPIO7
ANT_DET (NC)	41	42	GPIO8
ADC2	43	44	SIM_RST_N
USB_ID	45	46	SIM_CLK
ADC3	47	48	SIM_VCC
GPRS	49	50	SIM_PD_N
IGN	51	52	SIM_DIO
ON_N	53	54	HEADSET_P
HDST_INT_N	55	56	Chip SIM reset
MIC2_P	57	58	GPS_PWR
AGND	59	60	NC
MIC1_P	61	62	MIC1_N
ALRT_N	63	64	NC
ALRT_P	65	66	NC
SPKR_N	67	68	Coin Cell
SPKR_P	69	70	MIC2_N

Table 3-3: Interface Specifications

Pin #	Signal Name	Description	I/O	Active H/L	Internal PU/PD	Parameter	Conditions	Level			
								Min	Typ	Max	Units
Power:											
1	GND	Ground									
2											
3											
4											
5	VCC	DC power supply	I			V_{IN}	VCC = 3.6 V	3.3	3.6	4.2	V
6						I_{MAX}		1.7	1.8	A	
7						I_{OFF}		40	50	uA	
8											
68	COIN CELL		I	H				1.8	3	3.25	V
58	GPS ANT POWER	Do not connect	I								V
27	VREF	Reference regulator output	O					1.8	2.6	3	V 300 mA
Control:											
16	WKUPI_N	H24 wakeup input	I	L	PU	V_{IH} V_{IL}	$I_{OUT} \leq 2mA$	2.0	2.6 0	2.9 0.4	V
26	WKUPO_N	Host wakeup output	O	L		V_{OH} V_{OL}	$I_{OUT} \leq 2mA$	2.15	2.6 0	0.45	V
25	RESET_N	Reset signal output	O	L		V_{OH} V_{OL}	$I_{OUT} \leq 2mA$	2.15	2.6 0	0.45	V
53	ON_N	On/Off switch	I	L	PU	V_{IH} V_{IL}		2.0	2.6 0	2.9 0.4	V
51	IGN	Ignition input	I	H	PD	V_{IL} V_{IH}		0 3.3		0.4 16	V
39	TXEN_N	Transmit indicator	O	H		V_{OH} V_{OL}	$I_{OUT} \leq 2mA$	2.15	2.6 0	0.45	V
49	GPRS	GPRS/EGPRS coverage indicator	O	H			$I_{OUT} \leq 2mA$	2.15	2.6 0	0.45	V
Primary UART:											

Table 3-3: Interface Specifications (Cont.)

Pin #	Signal Name	Description	I/O	Active H/L	Internal PU/PD	Parameter	Conditions	Level			
								Min	Typ	Max	Units
21	TXD_N	UART1 TXD	I	L	PD	V_{IH} V_{IL}	$I_{OUT} \leq 2mA$	2.0	2.6 0	2.9 0.4	V
11	RXD_N	UART1 RXD	O	L		V_{OH} V_{OL}		2.15	2.6 0	0.45	
9	RTS_N	UART1 RTS	I	L		V_{IH} V_{IL}		2.0	2.6 0	2.9 0.4	
15	CTS_N	UART1 CTS	O	L		V_{OH} V_{OL}		2.15	2.6 0	0.45	
19	DTR_N	UART1 DTR	I	L	PU	V_{IH} V_{IL}		2.0	2.6 0	2.9 0.4	
13	DSR_N	UART1 DSR	O	L		V_{OH} V_{OL}		2.15	2.6 0	0.45	
17	DCD_N	UART1 DCD	O	L		V_{OH} V_{OL}		2.15	2.6 0	0.45	
23	RI_N	UART1 RI	O	L		V_{OH} V_{OL}		2.15	2.6 0	0.45	
Secondary UART:											
29	RXD2_N	Do not connect	O	L							
31	TXD2_N	Do not connect	I	L	PD						
33	RTS2_N	Do not connect	I	L	PD						
35	CTS2_N	Do not connect	O	L							
USB I/F:											
10	USB_VBUS	USB bus power	I					4.75	5	5.25	V
12	USB_DP	USB bus serial data	I/O	H						3.6	V
14	USB_DN	USB bus serial data	I/O	L							
45	USB_ID	Do not connect	I	L							
SIM I/F:											

Table 3-3: Interface Specifications (Cont.)

Pin #	Signal Name	Description	I/O	Active H/L	Internal PU/PD	Parameter	Conditions	Level			
								Min	Typ	Max	Units
50	SIM_PD_N	SIM presence detect	I	L	PU	V_{IH} V_{IL}	$I_{OUT} \leq 2mA$	2.0	2.6 0	2.9 0.4	V
48	SIM_VCC	SIM supply	O	L				1.5	3	3.05	V
44	SIM_RST_N	SIM reset	O	L		V_{IH} V_{IL}		2.7 1.65	2.85 1.8	3 1.95	V
52	SIM_DIO	SIM serial data	I/O	H				2.7 1.65	2.85 1.8	3 1.95	
46	SIM_CLK	SIM clock	O	H				2.7 1.65	2.85 1.8	3 1.95	
56	Chip SIM reset	Chip SIM reset (In case Chip SIM incorporated, short-circuit this pin to pin 44).	I	L							
Digital Audio:											
18	PCM_DIN	Digital audio receive	I	H	PD	V_{IH} V_{IL}	$I_{OUT} \leq 2mA$	2.0	2.6 0	2.9 0.4	V
20	PCM_DOUT	Digital audio transmit	O	H		V_{OH} V_{OL}		2.15	2.6 0	0.45	
22	PCM_CLK	Digital audio clock	O	H		V_{OH} V_{OL}		2.15	2.6 0	0.45	
24	PCM_FS	Digital audio frame sync.	O	H		V_{OH} V_{OL}		2.15	2.6 0	0.45	

Table 3-3: Interface Specifications (Cont.)

Pin #	Signal Name	Description	I/O	Active H/L	Internal PU/PD	Parameter	Conditions	Level			
								Min	Typ	Max	Units
General Purpose I/O:											
28	GPIO1	General purpose I/O	I/O		PU	V_{IH} V_{IL}	$I_{OUT} \leq 2mA$	2.0	2.6	2.9	V
30	GPIO2	General purpose I/O	I/O		PU			0	0.4		
32	GPIO3	General purpose I/O	I/O		PU						
34	GPIO4	General purpose I/O	I/O		PU						
36	GPIO5	General purpose I/O	I/O		PU	V_{OH} V_{OL}		2.15	2.6	0.45	
38	GPIO6	General purpose I/O	I/O		PU						
40	GPIO7	General purpose I/O	I/O		PU						
42	GPIO8	General purpose I/O	I/O		PU						
Analog Audio:											
67	SPKR_N	Earpiece negative	O			R_L	Differential		32		Ω
69	SPKR_P	Earpiece positive	O			AV_{pp}				1.8	V
63	ALRT_N	Alert speaker negative	O			R_L	Differential		8		Ω
65	ALRT_P	Alert speaker positive	O			AV_{pp}				5.0	V
61	MIC1_P	Microphone input positive	I			R_{IN}	Differential		1		k Ω
62	MIC1_N	Microphone input negative	I			AV_{pp}		2	10	50	mV
59	AGND	Audio ground									
57	MIC2_P	Headset microphone input positive	I			R_{IN}	Differential		1		k Ω
70	MIC2_N	Headset microphone input negative	I			AV_{pp}		2	10	50	mV

Table 3-3: Interface Specifications (Cont.)

Pin #	Signal Name	Description	I/O	Active H/L	Internal PU/PD	Parameter	Conditions	Level			
								Min	Typ	Max	Units
54	HDST_SPKR	Headset Speaker output	O			R_L	Single Ended		32	1.8	Ω
						AV_{pp}					V
55	HDST_INT_N	Headset detect interrupt	I		47k PU	V_{IH} V_{IL}	$I_{OUT} \leq 2mA$	2.0	2.6 0	2.9 0.4	V
A/D (ADC):											
37	ADC1	General purpose A/D	I			V_{IN}		0		2.9	V
43	ADC2	General purpose A/D	I			V_{IN} active		0		2.6	V
47	ADC3	General purpose A/D	I								
Not Connected:											
41	ANT_DET	Do not connect									
60	NC	Do not connect									
64	I2C_SCL	Do not connect									
66	I2C_SDA	Do not connect									

Note: $R(PD) = 210k\Omega$, $R(PU) = 390k\Omega$

Chapter 4: Mechanical Specifications

Board Dimensions

Figure 4-1 describes the H24 mechanical characteristics.

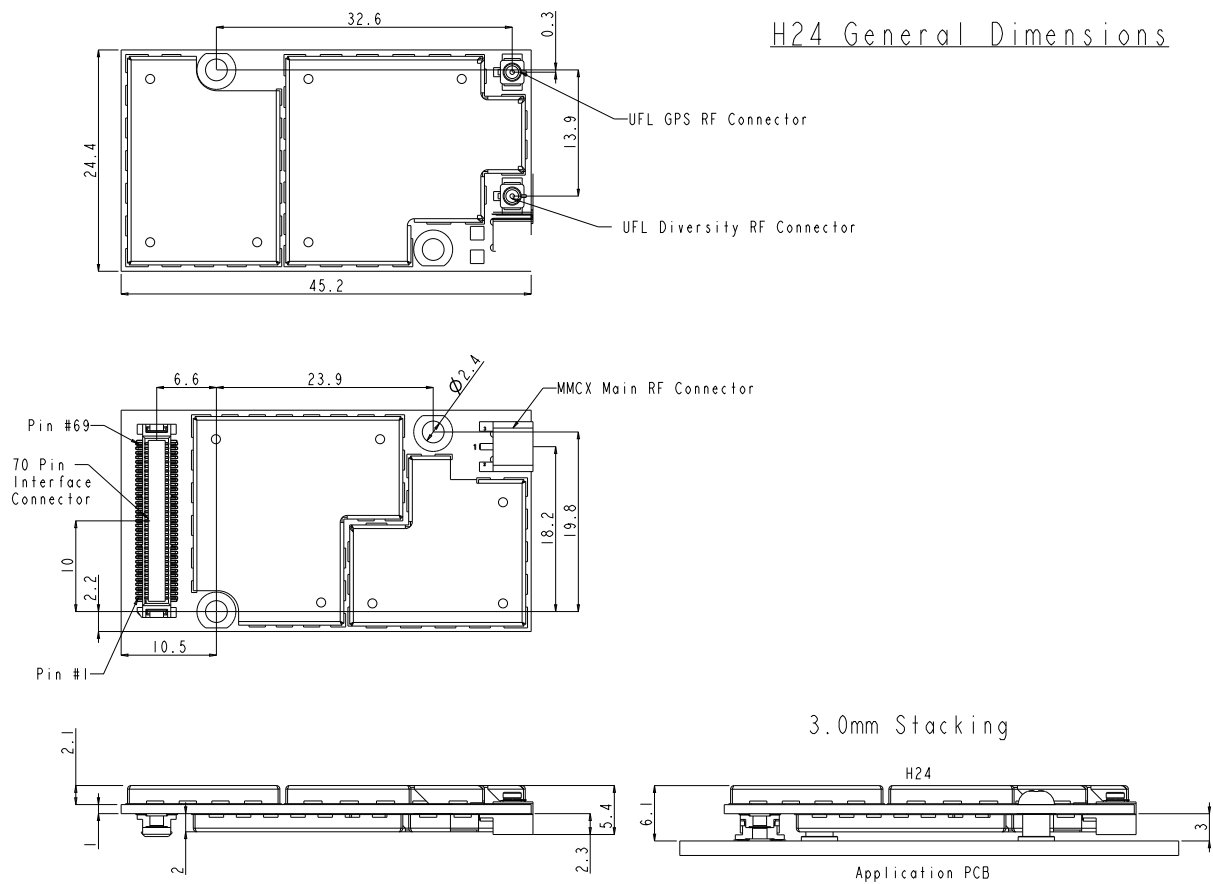

Figure 4-1: H24 Mechanical Characteristics

Interface Connector Specifications

The H24 uses a single 70-pin, 0.5 mm pitch, board to board connector for the application interface, as described in [Table 4-1](#).

Table 4-1: H24 interface connector options

H24 Connector	Mating Connector	Stacking Height
Molex 53748-0708	Molex 52991-0708	3.0 mm

[Figure 4-2](#) shows the H24 interface connector.

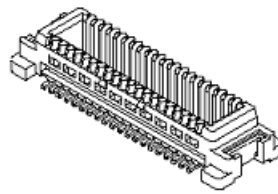

53748-0708 3.0mm

Figure 4-2: H24 Interface Connector

[Table 4-2](#) describes the H24 interface connector characteristics.

Table 4-2: Interface Connector Specifications

Parameter	53748 (3.0 mm)
Contacts	70
Rows	2
Pitch	0.5 mm
Maximum Current	500 mA
Maximum Voltage	50 V
Contact Resistance	50 m Ω maximum
Insulation Resistance	100 M Ω minimum
Durability	50 mated cycles maximum
Stacking Height	3.0 mm
Mates with	Molex 52991-0708

Mating Connector

The mating connector incorporates the same electrical and mechanical characteristics as the corresponding H24 interface connector, and is described in [Table 4-2](#).

[Figure 4-3](#) provides a reference drawing of the mating connector mechanical dimensions.

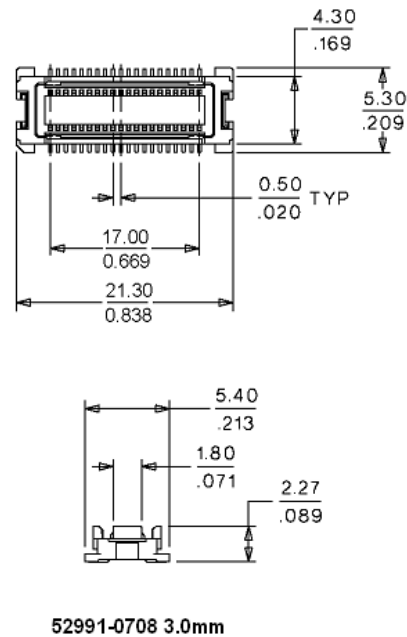

Figure 4-3: Mating Connector Dimensions

For more information on the H24 mating connector, please refer to the Molex web site at <http://www.molex.com/molex/index.jsp>.

MMCX Connector Specifications

The H24 uses a standard MMCX receptacle connector for the radio interface.

Figure 4-4 shows the MMCX connector dimensions.

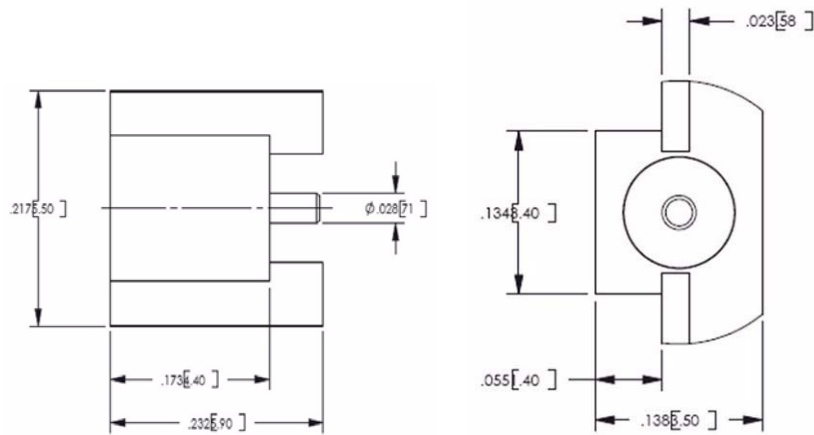

Figure 4-4: MMCX Connector Dimensions

Table 4-3 describes H24 RF connector characteristics.

Table 4-3: RF Connector Specifications

Parameter	Specifications
Rated Voltage	335 V _{RMS}
Impedance	50 Ω
Contact Resistance	5 mΩ center contact 2.5 mΩ outer contact
Insulation Resistance	1000 MΩ
Insertion Force	3.4 lbs maximum
Withdrawal Force	4.5 lbs maximum
Contact Retention Force	4 lbs maximum
Durability	500 mated cycles maximum

Mating Connector

The RF mating connector should be a standard MMCX plug connector or cable assembly, which corresponds to the H24 MMCX connector specifications.

Any standard MMCX connector or application from different manufacturers may be mated with H24.

Such a cable assembly example is the Huber-Suhner PN 11_MMCX-50-1-2/111_OH, which is illustrated in Figure 4-5.

Item description 11_MMCX-50-1-1/111_OH	
Connector Description	Straight cable plug for flexible cable
Series / Pattern Highlights	• MMCX – Type / Pattern 11 • SUHNER full crimp cable attachment
	
Item number	22651666
Data sheet	11_MMCX-50-1-1/111_O
Outline drawing	11_MMCX-50-1-1/111_O
Catalogue drawing	11_MMCX-50-1-1/111_O
Related documents	Assembly Instruction
2002/95/EC (RoHS)	<input checked="" type="checkbox"/> compliant
Interface Standards	SUHNER-MMCX
Mechanical data Jump to [Top]	
Cable Entry Centre Contact	crimped
Cable Entry Outer Contact	crimped
Engangement Force max	15 N
Disengagement F. min	6 N
Disengagement F. max	15 N
Dielectric Size	1
Electrical data Jump to [Top]	
Impedance	50 Ω
Interface Freq max	≤ 6 GHz
Environmental and general data Jump to [Top]	
Operating Temp min	-55 °C
Operating Temp max	155 °C
Weight	0.0009 kg
Number of Matings	500

Figure 4-5: Optional MMCX Cable Assembly

U.FL Connector Specifications

The H24 uses a standard U.FL receptacle connector for the radio interface.

Figure 4-6 shows the U.FL connector dimensions.

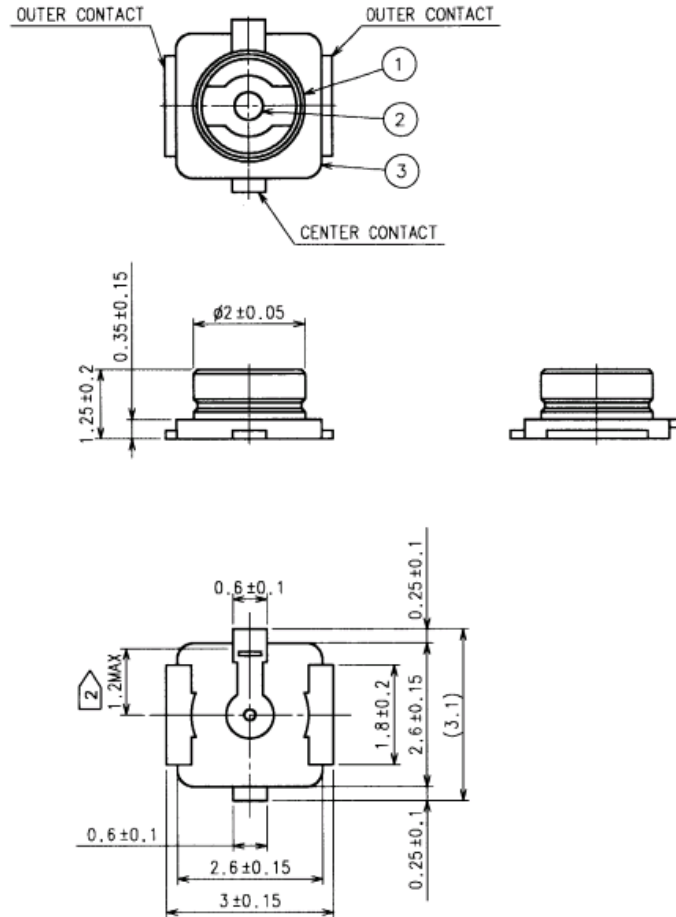

Figure 4-6: U.FL Connector Dimensions

Table 4-4 describes the U.FL connector characteristics.

Table 4-4: U.FL Connector Specifications

Parameter	Specifications
Characteristic Impedance	50 Ohms
Frequency Range	DC to 6 GHz
VSWR (mated pair)	1.30 max DC to 3 GHz 1.40 max 3 to 6 GHz (cable dependent)
Insertion Loss (connectors only)	0.24 dB max DC to 6 GHz

Table 4-4: U.FL Connector Specifications (Cont.)

Parameter	Specifications
Rated voltage	60 VAC (rms) - standard recept (Styles A, B)
Dielectric Withstanding Voltage	200 VAC, 50 Hz for 1 min (at sea level)
Insulation Resistance	500 Megohms min
Contact Resistance (connectors only)	20 milliohms max (Center) 10 milliohms max (Outer, Plug) 10 milliohms max (Outer, Receptacle)
Durability	30 cycles - standard recept (Styles A, B)
Disengagement Force	2N min perpendicular 4N min orthogonal
Center Contact Retention force	0.15N min
Tape/Reel Packaging (receptacle)	12mm carrier per EIA-481
Operating Temperature	40°C to +90°C

Mating Connector

The RF mating connector should be a standard U.FL plug connector or cable assembly, which corresponds to the H24 U.FL connector specifications.

Only Hirose U.FL mating cable may be mated with H24. A family of Hirose mating cables are available.

Such a cable assembly example is the Hirose U.FL-LP-040 is U.FL-R-SMT, which is illustrated in [Figure 4-7](#).

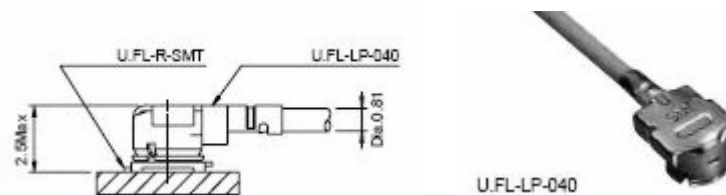

Figure 4-7: U.FL Mating Connector

For more details regarding Hirose mating cable assemblies, refer to http://www.hirose.co.jp/cataloge_hp/e32119372.pdf.

H24 Mounting

The H24 incorporates 2 mechanical holes for installing the module onto the application board. The holes are 2.4 millimeters in diameter, which accommodates several types of mechanical elements.

Several mechanical approaches may be applied to mount and fasten H24 to the application board. Using M2 screws with suitable washers to mount the module onto spacers, a bracket or chassis is a recommended design.

Special attention must be paid to the area surrounding the H24 mounting holes. A grounding pad of 4.4 millimeters in diameter surrounds these holes. The diameter and area of this pad must not be exceeded by any mechanical or electrical element. Several electrical components, which are not shielded, are located near the holes. These components must not be in contact with the mounting elements or with other parts of the application board, and care must be taken to avoid any damage.

Figure 4-8 depicts the H24 mounting area.

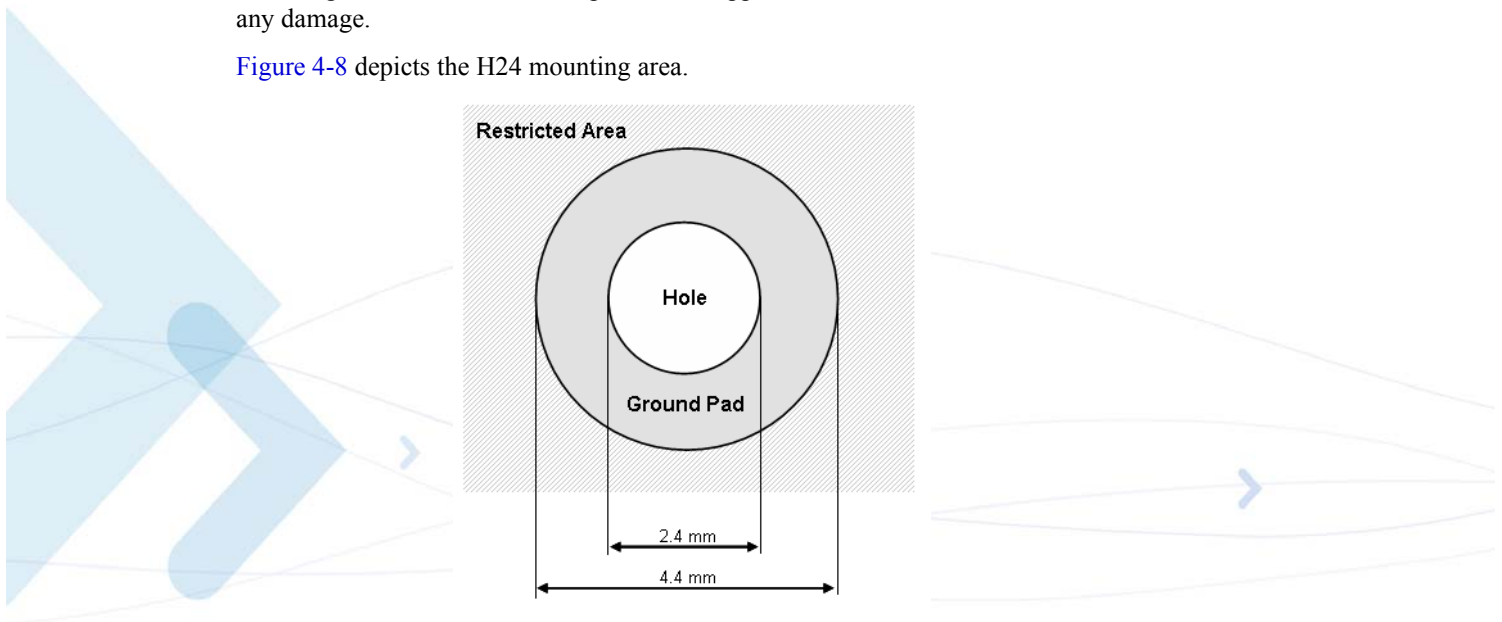

Figure 4-8: H24 Mounting Area

The holes are used for mechanical mounting of H24 to the application board but also for grounding support. Using conductive elements to install H24, significantly improves the overall grounding of the module and therefore improves the H24 performance and stability.

It is required to use screws or other mechanical elements to fasten H24 to the application board, but it is highly recommended to use conductive elements to improve the module's performance.

The preferred mounting screw head types are:

- "Allen" head with a chamfer - the best choice.
- "Star" head - good.
- "Philips" head - may cause damage to nearby components.

Chapter 5: Service and Testing

Service

This section provides contact information for any possible queries that may arise, for example:

- Have questions?
- Having trouble getting the Developer Board set up?
- Technical questions?
- Configuration questions/problems?
- Technical operating problems?
- Need documentation?

Who to Contact?

Use the following email address to contact customer assistance:

M2M.CustomerCare@motorola.com

Required Query Information

Every new call/problem report, directly from a Direct Customer or from a distributor, should be directed to the help desk email address noted above in “Who to Contact?”. It is recommended to report each individual issue in a separate email. The following information is required when reporting a problem:

- Customer name and address
- Customer contact information for this request, including:
 - Name
 - Telephone
 - Fax number
 - Mobile number
 - Email address
- Product name (H24)
- Software version of the unit (ATI8i9 command) or model number
- PCB version (located on the PCB near the RF connector).
- In addition to the information requested above, send the following AT commands and the HyperTerminal log with the responses:
 - **AT+CMEE=2 //** to get textual error message
 - **AT+CPIN? //** to get SIM card status

- **AT+CREG?** // to see if the TXVR is registered to the network
- **AT+CSQ** // to get the signal strength (RX level)
- **AT+CGSN** // to read the IMEI number of the unit
- **AT+S** // to get the setting of basic AT commands
- **AT+CMER=0,0,1,1** // to get messages and indicators from the handset display to the DTE

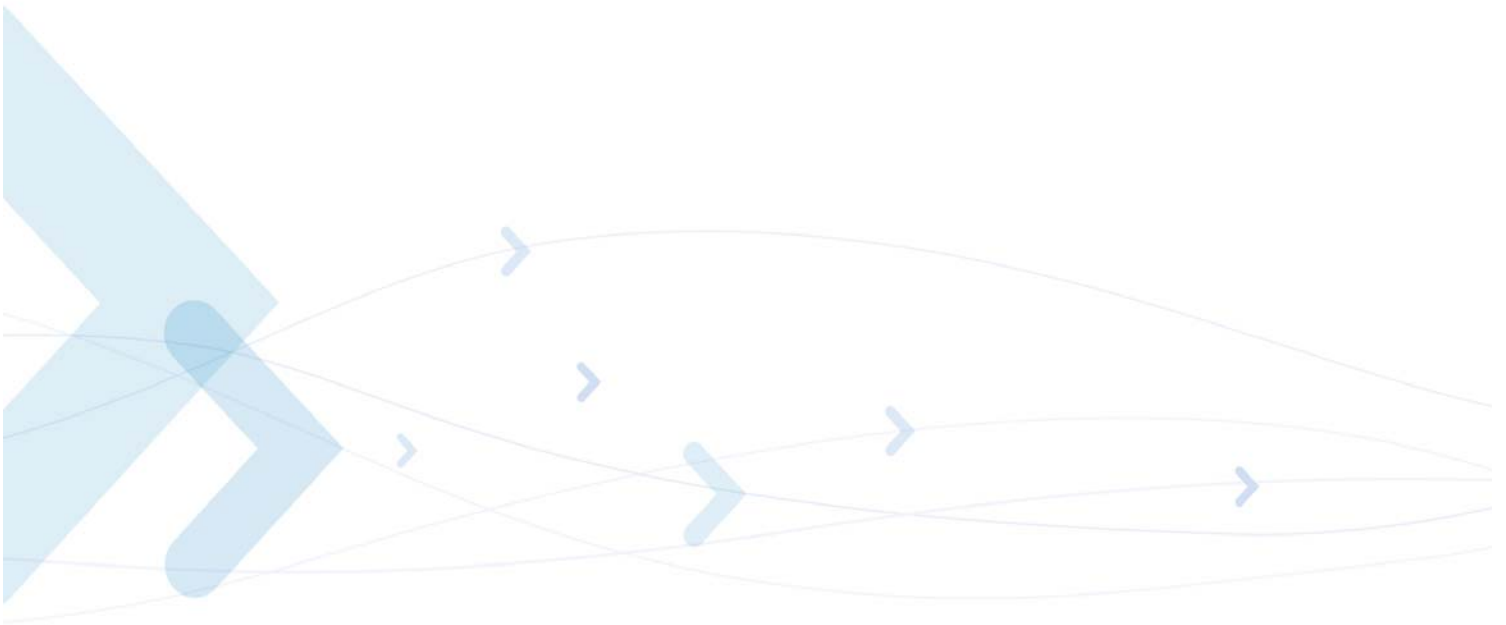

Acronyms and Abbreviations

Abbreviation	Full Name
A	
AMR	Adaptive Multi Rate
AOC	Advice of Charge
B	
BR	Baud Rate
bps	Bits Per Second
C	
CSD	Circuit Switched Data
CTS	Clear to Send
D	
DCD	Data Carrier Detect
DCE	Data Communication Equipment (such as modems)
DCS	Digital Cellular System (GSM in the 1800MHz band)
DOC	Department of Communications (Canada)
DRX	Discontinuous Reception
DSP	Digital Signal Processor
DSR	Data Set Ready
DTE	Data Terminal Equipment (such as terminals, PCs and so on)
DTMF	Dual Tone MultiFrequency
DTR	Data Terminal Ready
DTX	Discontinuous Transmission
E	
EFR	Enhanced Full Rate
EGPRS	Enhanced General Packet Radio Service
EGSM	Extended Global System for Mobile Communications
EIRP	Effective Isotropic Radiated Power

Abbreviation	Full Name
EMC	Electromagnetic Compatibility
EOTD	Enhanced Observed Time Difference
EPOS	Electronic Point of Sale
ERP	Effective Radiated Power
ESD	Electrostatic Discharge
ETSI	European Telecommunication Standards Institute
F	
FCC	Federal Communications Commission (U.S.)
FR	Full Rate
FTA	Full Type Approval
G	
GCF	GSM Certification Forum
GPIO	General Purpose Input/Output
GPRS	General Packet Radio Service
GSM	Global System for Mobile Communications
H	
HR	Half Rate
HSDPA	High-Speed Downlink Packet Access
I	
IC	Integrated Circuit
L	
LNA	Low-noise Amplifier
M	
MMCX	Miniature Micro Coax
MO	Mobile Originated
MT	Mobile Terminated
O	
OEM	Original Equipment Manufacturer
P	
PCB	Printed Circuit Board
PCL	Power Class Level
PCM	Pulse Code Modulation
PCS	Personal Communication System (also known as GSM 1900)
PD	Pull Down

Abbreviation	Full Name
PDA	Personal Data Assistant
PDU	Packet Data Unit
PLL	Phase-locked Loop
PTCRB	PCS-1900 Type Certification Review Board (GSM North America)
PU	Pull Up
R	
R&TTE	Radio and Telecommunications Terminal Equipment
RMS	Root Mean Square
RI	Ring Indicator
RTS	Request To Send
S	
SAR	Specific Absorption Rate
SIM	Subscriber Identity Module
SMS	Short Message Service
SPI	Serial Peripheral Interface
T	
TDMA	Time Division Multiple Access
TIS	Transmitter Isotropic Sensitivity
TRP	Transmitter Radiated Power

Abbreviation	Full Name
--------------	-----------

U

- UART** Universal Asynchronous Receiver Transmitter
- USB** Universal Serial Bus
- USSD** Unstructured Supplementary Services Data

V

- VCC** Voltage Common Collector
- VSWR** Voltage Standing Wave Ratio

W

- WCDMA** Wideband Code Division Multiple Access

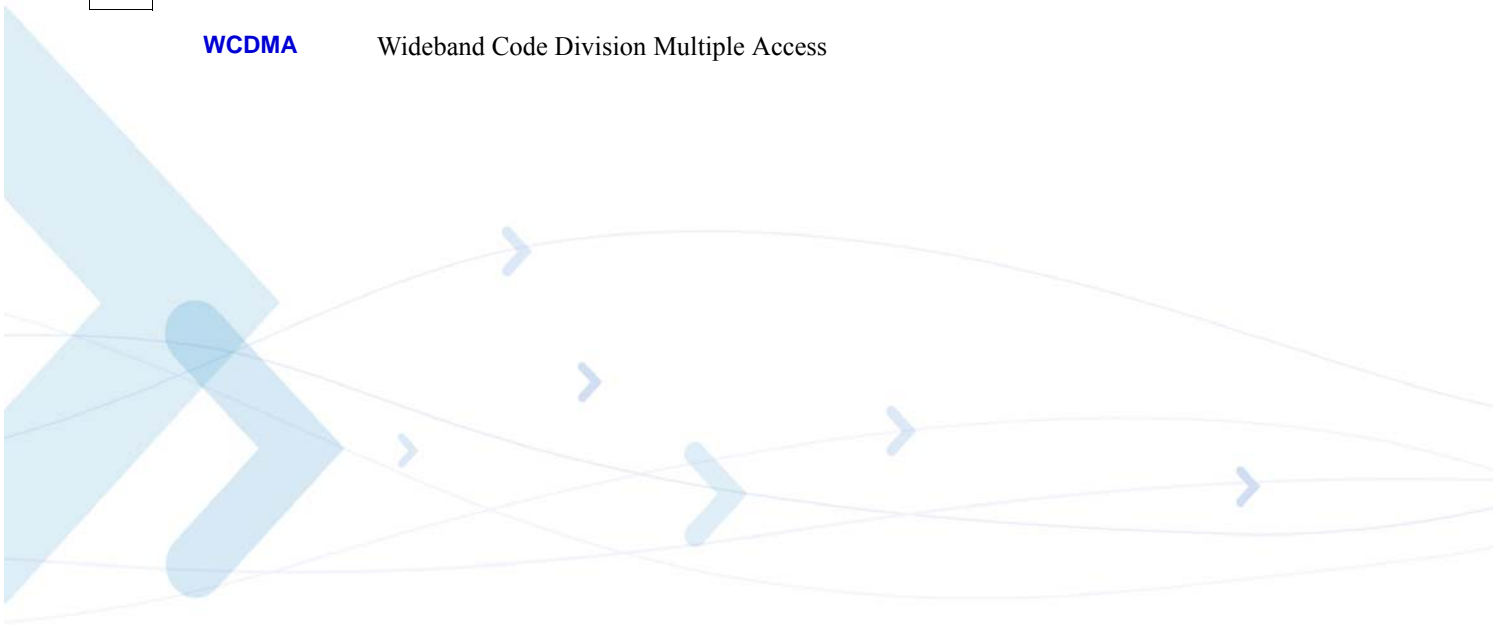

Index

A

Antenna Installation, [x](#)
Approvals
Regulatory, [6](#)

B

Block Diagram Description, [9](#)

E

Environmental
Specifications, [3](#)

H

H24
Abbreviations, [2](#)
Antenna Installation, [x](#)
Block Diagram Description, [9](#)
Product Specifications, [2](#)
Regulatory Approvals, [6](#)
Safety Precautions, [ix](#)
Standards, [x](#)
Terms and Abbreviations, [2](#)
User Operation, [ix](#)

O

Organization of Manual, [xix](#)

P

Physical Specifications, [2](#)
Precautions, [ix](#)
Product Specifications, [3](#)

R

Regulatory Approvals, [6](#)

S

Safety Precautions, [ix](#)
Specifications, [2](#)
Environmental, [3](#)
Physical, [2](#)
Standards, [x](#)

T

Terms, [2](#)

U

User Operation, [ix](#)

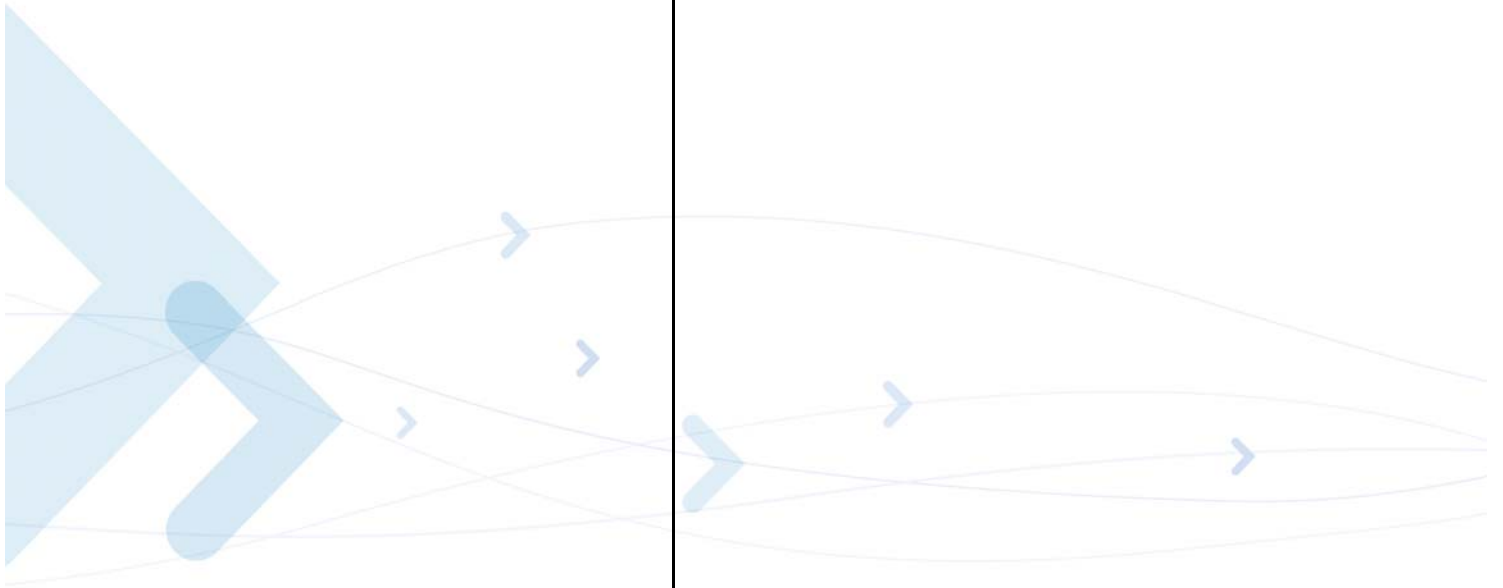

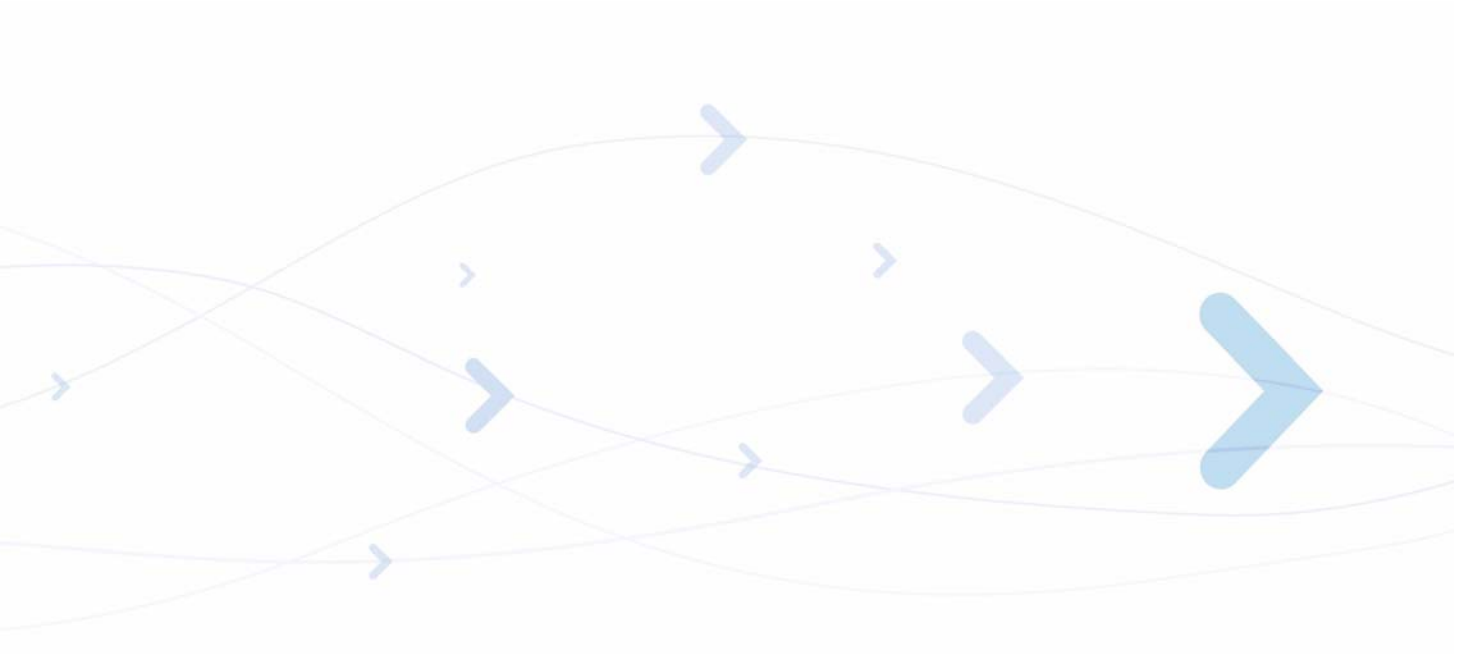

MOTOROLA and the Stylized M Logo are registered in the US Patent & Trademark Office.
All other product or service names are the property of their respective owners.
© Copyright 2007 Motorola, Inc.
Java™ Technology and/or J2ME™ : Java and all other Java-based marks are trademarks or registered trademarks of Sun Microsystems, Inc. in the U.S. and other countries.
UNIX® : UNIX is a registered trademark of The Open Group in the United States and other countries.



6802986C38-D