

Exhibit 7a. Measurement Procedures -- 47 CFR 2.947

This exhibit presents a summary of how the measurements were made.

7a.1 RF Power -- Pursuant to 47 CFR 2.947(c) and 47 CFR 2.1046

Method of Measurement (Conducted Output Power): Adaptation of TIA/EIA-603-A clause 2.2.1 for Pulsed Measurements

The RF output power is not adjustable by the user. The output power is controlled by the radio in response to the received signal strength or by or special radio service software. To obtain RF output power reading, the radio was programmed to utilize the maximum and minimum output power setting. To correct the average reading power meter, a setting of the duty cycle on the RF power meter was set to 16.667% for herein reported 6:1 TDM test signals.

A special DC/RF test fixture was utilized to interface with the radio test RF connector while simultaneously supplying the nominal operating voltage of 4.0V. The radio RF connector is utilized in all factory tuning and testing procedures, and provides a 50 ohm connection to the transmitter path while disconnecting the radio antenna. All conducted measurements were performed via this test port.

NOTE: This DC/RF test fixture is not offered for sale.

Method of Measurement (Effective Radiated Power): TIA/EIA-603-B 2.2.17.2

The ERP characteristic was measured while a radio was set to transmit a test mode CW signal at the maximum rated output power (+/- 5%) and was vertically mounted on a non-conducting platform/turntable in a RF Anechoic Chamber. The power received at an antenna located at the end of the chamber was recorded on a spectrum analyzer for a complete 360-degree rotation. The same procedure was repeated for 800 and 900 MHz sleeve reference dipole. The CW RF output power of the radio product was measured by a conducted means to determine the necessary input power for the reference dipole (after compensation for interface, cable, and antenna losses). The maximum power levels measured were compared to determine the antenna gain of the radio antenna in reference to the standard dipole. This relative antenna gain was used to scale the maximum RF conducted output power and determine the maximum herein reported ERP.

7a.2 Emission Mask-- Pursuant to 47 CFR 2.947(b) and 47 CFR 2.1049(h).

Method of Measurement: Per TIA/EIA-603-A clause 2.2.11

- (1) Set the radio for measurement of RF output power using the power test procedure in the service manual which employs a pseudo random data sequence per part 2.1049(h), and attach it to a spectrum analyzer through a 10 dB attenuator. The analyzer is to be set for peak detection with a video bandwidth of 3 times the resolution bandwidth setting, a span of 100 kHz, and a sweep period of 20 seconds.
- (2) Using a 30 kHz resolution bandwidth to assure that essentially all of the transmitted energy is measured, obtain a “rainbow” curve and adjust the analyzer setting so that the crest of the curve lies at the 0 dB reference locations. This is portrayed as blue line on the analyzer display.
- (3) Reduce the resolution bandwidth to 300 Hz to characterize the transmitter emission on-channel and adjacent channels spectral performance characteristic. This is portrayed as yellow line on the analyzer display of the figures.
- (4) Overlay the applicable emission mask on the analyzer display as red line.
- (5) Compare yellow line and red line to ensure that the spectrum never exceeds the applicable emission mask.

For Quad-QPSK Modulation:

32k Bits per Second Pseudo-Random Digital Modulation.

Vertical division: 10 dB/div.

Carrier Reference: Carrier Reference 0 dB corresponds to maximum and minimum peak output power settings, respectively.

For Quad-16QAM Modulation:

64k Bits per Second Pseudo-Random Digital Modulation

Vertical: 10 dB/div

Carrier Reference: Carrier Reference 0 dB corresponds to maximum and minimum peak output power settings, respectively.

For Quad-64QAM Modulation:

96k Bits per Second Pseudo-Random Digital Modulation

Vertical: 10 dB/div

Carrier Reference: Carrier Reference 0 dB corresponds to maximum and minimum peak output power settings, respectively.

One trace was used to capture transmitter performance, measured using a resolution bandwidth of 300 Hz, while the reference level was obtained by another trace, using a resolution bandwidth of 30 kHz. A third trace shows the applicable emission mask.

7a.3 Radiated Spurious Emissions -- Pursuant to 47 CFR 2.947(b) and 47 CFR 2.1053

Test Sites:

1. Open Area Test Site (OATS) of the Motorola EMC Lab, 8000 W Sunrise Blvd, Plantation, Florida 33322 which is accredited to ISO/IEC 25 from the American Association for Laboratory Accreditation (FCC Registration: 91932/Industry Canada: IC3679). The radiated emission testing was performed for minimum and maximum powers in transmit mode.
2. TIMCO Engineering Lab, 849 NW State Road 45; Newberry, Florida 32669

Method of Measurement: TIA/EIA-603-A clause 2.2.12

800-900 MHz Band

The equipment is placed on the turntable and placed in normal operation transmit mode of operation.

A broadband receiving antenna located 3 meters from the transmitter receives any signal radiated from the transmitter and its operational accessories. The antenna is adjustable in height and can be rotated for horizontal or vertical polarization. A spectrum analyzer covering the necessary frequency range is used to detect and measure any radiation received by the antenna.

The transmitter's modulated pseudo random digital signal is monitored and adjusted to obtain peak reading of received signals wherever they occur in the spectrum by:

- (1) Rotating the transmitter under test.
- (2) Adjusting the antenna height.

The testing procedure is repeated for both horizontal and vertical polarization of the receiving antenna. Relative signal strength is indicated on the spectrum analyzer connected to this antenna. The spectrum analyzer resolution bandwidth was set to 10 kHz for emissions below 1 GHz, and 1 MHz for higher frequency emissions. To obtain actual radiated signal strength for each spurious and harmonic frequency observed, a standard signal generator with calibrated output is connected to an antenna adjusted to in the range from 30 MHz to that harmonic frequency. This antenna is substituted for the transmitter under test. The signal generator output level is adjusted until a reading identical to that obtained with the actual transmitter is observed on the spectrum analyzer. Signal strength is then derived from the generator and appropriate cable losses due to set up. Measured emissions for both maximum and minimum transmit power levels are recorded in tables in Exhibit 6.

MOTotalk ISM Band Measurement

Source: FCC Public Notice DA 00-705 March 30, 2000. “*Filing and Measurement Guidelines for Frequency Hopping Spread Spectrum Systems*”

The following spectrum analyzer settings were used:

Span = wide enough to fully capture the emission being measured

RBW = 1 MHz for $f \geq 1$ GHz, 100 kHz for $f < 1$ GHz

VBW \geq RBW

Sweep = auto

Detector function = peak

Trace = max hold

The guidelines in ANSI C63.4-2003 were followed in maximizing the emissions of the EUT. A pre-amp and a high pass filter are required for this test in order to provide the measuring system with sufficient sensitivity. After allowing the trace to stabilize, the peak reading of the emission is the peak field strength, after applying the appropriate correction factors.

Once the emission is maximized, a CISPR 16 compliant EMC Receiver is employed in average detector mode to measure the average level of the emission (for emissions > 1 GHz). This level is measured and corrected and is used to determine compliance within the restricted band limits:

Equipment used for radiated emissions measurements (FL08 EMC Lab):

Site 3 Meters

Antenna Horn

Amp Amp #1

Duty Cycle Correction Factor: FCC Public Notice DA 00-705 also permits the application of a “duty cycle correction factor” to the reading obtained with the 10 Hz VBW that related to the dwell time per channel of the hopping signal, when this is less than 100 ms. This correction factor is determined using the formula $20 \log (\text{dwell time}/100 \text{ ms})$, and for the MOTotalk emission, this factor is:

Dwell time = $(274 \text{ symbols})/(3200 \text{ symbols/sec})/(8 \text{ frequencies}) = 10.70 \text{ ms}$

Correction factor $20 \text{ Log } (10.70 \text{ ms}/100 \text{ ms}) = -19.41 \text{ dB}$

While permissible, unless otherwise indicated in the test exhibit, this duty cycle is not applied to the test data collected.

7a.4 Frequency Stability -- Pursuant to 47 CFR 2.947(c) and 47 CFR 2.1055

Measuring the frequency accuracy of the iDEN time division multiplexed (TDM) transmitter needs special procedures for 3 reasons. First is the short (15 ms) nature of its TDM pulses, which preclude the use of an ordinary CW type digital frequency counter. Second, software in the radio prevents the radio from transmitting its TDM pulses unless it is receiving a signal on the trunking system control channel. Third, to maintain the very high stability (greater than that required by part 90 rules) needed for system operation, the radio transmitter frequency is controlled by an automatic frequency control loop in the radio's receiver which locks onto the system forward control channel produced by a compatible FCC certified part 90 base station. This process results in electronic adjustments of the synthesizer section of the radio, which is used for both transmission and reception.

As a result, unlike traditional transceivers which do not frequency lock to a remote base station reference frequency, the transmitter frequency accuracy is essentially independent of the voltage and temperature induced variations of the subject transceiver's frequency reference oscillator. Rather, the transceiver frequency stability is that of the remote base station, but degraded by any inaccuracy in the transceiver frequency locking process.

By locking onto a base station meeting the requirements of 47 CFR 90.213, which is necessary for the transceiver to function, the transceiver transmitter inherits the inherent 1.5 ppm or better stability of the compatible base station. To assure attainment of the frequency accuracy requirement (2.5 ppm accuracy requirement for the 800MHz band and the 0.5 ppm accuracy requirement for the 900MHz band) of part 90.213 for this transceiver, the frequency error is measured when locked to a base station simulator.

Frequency Error vs. temperature

The unit tested used a frequency of 858.45/813.45 MHz (800 MHz Band) and 937.48125/898.49375 MHz (900 MHz band). A Power Supply was controlled to provide a continuous 4.0 V_{DC} to the unit tested. The sensor leads from the power supply were attached to the input of the DC/RF test fixture in which the radio was placed. A Temperature Chamber was used to control a temperature range of -30 degree Celsius to +60 degree Celsius.

At each set point, a soak time of 20 minutes was used to ensure thermal penetration of the unit tested before each measurement of frequency error was taken. A soak time of 45 minutes was used at -30 degree Celsius to ensure thermal penetration of the unit tested because of the variance from the starting temperature of +25 degree Celsius. Soak cycles of 20 minutes each thereafter were used because of the fact that the set points were incremented at 10 degree (Celsius) steps.

The measurement was taken by placing the unit tested into a phone call to the Motorola R2660C. The iDEN 3:1 Call Test on the Motorola R2660C was controlled to facilitate the call. Once the call had been established, a Hewlett Packard Model 89441A gathered measurements of the frequency error and recorded it to a data file.

After having taken measurement at a specific set point in the temperature range previously specified, the iDEN 3:1 Call test on the Motorola R2660C was terminated. The Temperature Chamber would proceed to its next increment and repeat the test execution process at the end of that particular soak cycle. The process was continued until measurements were made at each of the specified temperatures in the temperature range previously mentioned.

For MOTotalk measurement, a special test mode which is not accessible by user was used. Frequency was set to 915.525 MHz (ISM band frequency) and transmission started after the soaking cycle on the device under test. A Hewlett Packard Model 89441A was used to measure the maximum frequency excursion due to temperature extremes.

After having taken measurement at a specific set point in the temperature range previously specified, the transmission was terminated by sending a command. The Temperature Chamber would proceed to its next increment and repeat the test execution process at the end of that particular soak cycle. The process was continued until measurements were made at each of the specified temperatures in the temperature range previously mentioned.

Frequency Error vs. voltage

The unit tested used a frequency of 858.45/813.45 MHz (800 MHz Band) and 937.48125/898.49375 MHz (900 MHz band). A Power Supply was controlled to provide a voltage range of 3.55 V_{DC} to 4.2VDC to the unit tested. The sensor leads from the power supply were attached to the input of the battery eliminator of the unit tested.

The measurements were taken by placing the unit tested into a phone call to the Motorola R2660C. The iDEN 3:1 Call Test on the Motorola R2660C was controlled to facilitate the call. Once the call had been established, a Hewlett Packard Model 89441A took measurement of the frequency error and recorded it to a data file.

For MOTotalk measurement, a special test mode which is not accessible by user was used. Frequency was set to transmit at 915.525 MHz (ISM band frequency). A Hewlett Packard Model 89441A was used to measure the maximum frequency excursion due to voltage extremes.

After having taken a frequency error measurement at 4.2V_{DC}, the Power Supply's output was reduced by 0.1 V_{DC}. The measurement process was repeated until Frequency Error measurements were made in 0.1 V_{DC} steps of each of the specified voltages in the range previously mentioned.

Method of Measurement: Proprietary

Since the transmitter frequency is locked to the frequency of the compatible base station via the receiver in this transceiver, frequency accuracy data was measured with the transceiver locked onto a base station transmitter emulated by a Motorola R2660C Service Monitor as shown in Figure 7-1. This was done using the Quad-16QAM time division duplex (TDD) characteristic of the transceiver wherein it was placed into a TDD mode of transmission as normally used to make a call to a landline phone.

During the test the transceiver was receiving a very high accuracy forward control channel frequency signal from the compatible base station emulator and TDD transmitting a signal on the reverse control channel at a frequency 45 MHz lower in the 800MHz band, (39 MHz lower in the 900MHz band) corresponding to the normally assigned frequency separation. A Hewlett Packard model 89441A signal analyzer was used to measure the centroid frequency of the emission. The frequency of the transceiver was measured as operating voltage or temperature was varied, and compared to the frequency of the assigned channel.

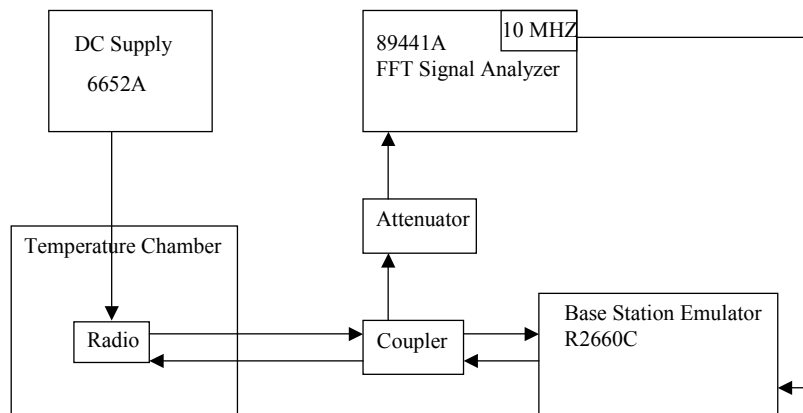

Figure 7a-1: Transmit Frequency Measurement Setup

7a.5 Power Line Conducted Spurious Output Voltage Pursuant 47 CFR 15.107

Test Site:

Electrical Engineering Screen Room of the Motorola EMC Lab, 8000 W Sunrise Blvd, Plantation, Florida 33322 which is accredited to ISO/IEC 25 from the American Association for Laboratory Accreditation (FCC Registration: 91932/Industry Canada: IC3679).

Method of Measurement: TIA/TEA-603-A clause 2.1.3

Connect the receiver to the power line through a line stabilization network. A spectrum analyzer of nominal 50-Ω impedance is connected to one terminal (“neutral”) of the line stabilization network. The spectrum analyzer is then tuned to search for spurious outputs from 150 kHz to 30 MHz, pursuant to 47 CFR 15.107. All spurious voltages are recorded. Six highest local maxima are noted, measured with a “Quasi-peak” and “Average” detectors, and then tabulated.

7a.6 Bluetooth Carrier Frequency Separation – Pursuant 47 CFR 15.247(a)(1)

The RF output port of the Device under Test (DUT) is directly coupled to the input of the spectrum analyzer through a specialized RF connector. A power supply is used for the supply voltage. The DUT has its hopping function enabled. The following spectrum analyzer settings are used:

Span = 5 MHz (wide enough to capture the peaks of two adjacent channels)

Resolution Bandwidth (RBW) = 100 kHz ($\geq 1\%$ of the span)

Video (or Average) Bandwidth (VBW) = 300 kHz (\geq RBW)

Sweep = auto

Detector function = peak

Trace = max hold

The trace is allowed to stabilize. The marker-delta function is used to determine the separation between the peaks of the adjacent channels. The limit is specified to be greater than the 20 dB bandwidth of the hopping channel.

7a.7 Bluetooth Number of Hopping Frequencies – Pursuant 47 CFR 15.247(a)(1)(iii)

The RF output port of the DUT is directly coupled to the input of the spectrum analyzer through a specialized RF connector. A power supply is used for the supply voltage. The DUT must have its hopping function enabled. The following spectrum analyzer settings are used:

Span = 100 MHz (the frequency band of operation)

RBW = 100 kHz ($\geq 1\%$ of the span)

VBW = 100 kHz (\geq RBW)

Sweep = auto

Detector function = peak

Trace = max hold

The trace is allowed to stabilize. The limit is specified as a minimum of 15 non-overlapping channels over a total span of at least 75 MHz.

7a.8 Time of Occupancy (Dwell Time) – Pursuant 47 CFR 15.247(a)(1)(iii)

The RF output port of the DUT is directly coupled to the input of the EMC analyzer through a specialized RF connector. A power supply is used for the supply voltage. The DUT has its hopping function enabled. The following spectrum analyzer settings are used:

Span = zero span, centered on a hopping channel

RBW = 1 MHz

VBW \geq RBW

Sweep = as necessary to capture the entire dwell time per hopping channel

Detector function = peak

Trace = max hold

Use the marker-delta function to determine the dwell time. Subparagraph 15.247(a)(1)(iii) states “The average time of occupancy on any channel shall not be greater than 0.4 seconds within a period of 0.4 seconds multiplied by the number of hopping channels employed.” This equates to a time period of 31.6 seconds.

A single measurement cannot be made over a 31.6 second period due to the coarse resolution in the time domain. A sweep is first made in a 4 second period. The resolution is not fine enough to capture the dwell time in each burst but the periodicity can be seen. The number of time slots occupied (40) can be extrapolated to show the number of time slots occupied within a 31.6 second period ($40 \bullet \frac{32s}{4s} = 320$).

Another sweep is made over a 5 ms period, allowing the measurement of the duration of one time-slot. This active time can be multiplied by the number of transmissions in a 31.6 second period (320) to derive the total dwell time in a 31.6 second period. The specification is 400 ms maximum dwell time.

7a.9 20 dB Bandwidth – Pursuant 47 CFR 15.247(a)(1)(ii)

The RF output port of the DUT is directly coupled to the input of the spectrum analyzer through a specialized RF connector. A power supply is used for the supply voltage. The DUT must have its hopping function enabled. The following spectrum analyzer settings are used:

Span = 2 MHz (approximately 2 to 3 times the 20 dB bandwidth, centered on a hopping channel)

RBW = 50 kHz ($\geq 1\%$ of the 20 dB bandwidth)

VBW = 50 kHz (\geq RBW)

Sweep = auto

Detector function = peak

Trace = max hold

The DUT transmits at its maximum data rate. The trace is allowed to stabilize. The marker-to-peak function is used to set the marker to the peak of the emission. The marker-delta function is used to measure 20 dB down one side of the emission. The marker-delta function is reset and the marker is moved to the other side of the emission, until it is (as close as possible to) even with the reference marker level. The limit is specified as a maximum of 1 MHz.

7a.10 Peak Output Power – Pursuant 47 CFR 15.247(b)(1)

The RF output port of the DUT is directly coupled to the input of the spectrum analyzer through a specialized RF connector. A power supply is used for the supply voltage. The DUT must have its hopping function enabled. The following spectrum analyzer settings are used:

Span = 5 MHz (approximately 5 times the 20 dB bandwidth, centered on a hopping channel)

RBW = 1 MHz ($>$ the 20 dB bandwidth of the emission being measured)

VBW = 1 MHz (\geq RBW)

Sweep = auto

Detector function = peak

Trace = max hold

The trace is allowed to stabilize. The marker-to-peak function is used to set the marker to the peak of the emission. The indicated level is the peak output power. The maximum level is specified as 1 Watt.

7a.11 Band-Edge Compliance of RF Conducted Emissions – Pursuant 47 CFR 15.247(c)

The RF output port of the DUT is directly coupled to the input of the spectrum analyzer through a specialized RF connector. A power supply is used for the supply voltage. The following spectrum analyzer settings are used:

Span = 10 MHz (wide enough to capture the peak level of the emission operating on the channel closest to the band edge, as well as any modulation products which fall outside of the authorized band of operation)

RBW = 100 kHz ($\geq 1\%$ of the span)

VBW = 100 kHz (\geq RBW)

Sweep = auto

Detector function = peak

Trace = max hold

The trace is allowed to stabilize. The marker is set on the emission at the band edge, or on the highest modulation product outside of the band, if this level is greater than that at the band edge. The marker-delta function is enabled and then the marker-to-peak function is used to move the marker to the peak of the in-band emission. The marker-delta value displayed must be greater than 20 dB.

Now, using the same instrument settings, the hopping function of the DUT is enabled. The trace is allowed to stabilize. The same procedure listed above is followed to determine if any spurious emissions caused by the hopping function also comply with the specified limit.

7a.12 Spurious RF Conducted Emissions – Pursuant 47 CFR 15.247(c)

The RF output port of the DUT is directly coupled to the input of the spectrum analyzer through a specialized RF connector. A power supply is used for the supply voltage. The following spectrum analyzer settings are used:

Span = wide enough to capture the peak level of the in-band emission and all spurious emissions (e.g., harmonics) from the lowest frequency generated in the EUT up through the 10th harmonic. Several plots are required to cover this entire span.

RBW = 100 kHz

VBW = 100 kHz (\geq RBW)

Sweep = auto

Detector function = peak

Trace = max hold

7a.13 BT Spurious RF Radiated Emissions - Pursuant 47 CFR 15.247(c)

Measurement was done at TIMCO Engineering Lab. Test set up and procedure was provided in the Test Report (Exhibit 6).

7a.14 Measurement Equipment List ---- 47 CFR 2.947(d)

1. Spectrum Analyzer
 - H.P. 8566B
 - H.P. 8563E
 - Rhode & Schwarz ESI26
 - Rhode & Schwarz ESMI
 - Rhode & Schwarz FSEB
2. Vector Signal Analyzer
 - H.P. 89441A
3. Communications System Analyzer
 - Motorola R-2660 MIRS Digital Communication System Analyzer
4. Oscilloscope
 - HP 54616B, Oscilloscope
 - Tektronix, Model TCP202, Current Probe
5. RF Signal Generator
 - H.P. 8656A
 - Rhode and Schwarz SMP22
 - H.P. E4420A
6. Power Meter
 - H.P. 437B Power Meter
 - H.P. 8482A Power Sensor
 - Gigatronics 8651A Power Meter
 - Gigatronics 80701A Power Sensor
7. Multimeter
 - Keithley 2001 Multimeter
8. Power Supply
 - Motorola Lithium Ion Battery, Kit #: NTN 5705A
 - DC Power Supply, H.P., Model: 6652A
 - DC Power Supply, H.P., Model: 6632A
 - DC Power Supply, H.P., Model: 6032A
 - Battery Charger, Model: NNTN4680A
 - DC/RF Test Fixture, 22000uF shunt capacitor / series 0.2 ohm resistor

9. RF Load
 - Weinschel Engineering, Model: 9305-30, 20 Watt, 30 dB Attenuator
 - Weinschel Engineering, Model: 9305-10, 20 Watt, 10 dB Attenuator
 - Narda, Model: MOD766-30, 20 Watt, 30 dB Attenuator
10. Filter
 - Trilithic, Model: X5HX1612-0-75-AA, High Pass Filter
 - Trilithic, Model: R9H1-1G4/8G-28A, High Pass Filter
11. Amplifier
 - MITEQ AFS5-00101800-25-ULN, 1-18GHz, 25dB Gain Amplifier
 - PST 10W Amplifier
12. Antenna Chamber
 - Anechoic Chamber, RF/EMI Shielded Enclosure
13. Antenna
 - Watkins - Johnson, 0.5 GHz - 12.4 GHz, Model WJ-48010
 - Watkins - Johnson, Model: AR122
 - A.H. Systems Inc., Model: SAS-200/571, 700MHz - 18GHz, Double Ridge Guide Horn
 - EMCO, Model: 3141, 20MHz – 1GHz, Biconilog
 - Schaffner-Chase EMC Ltd., Bilog Antenna, Model CBL6112B
 - Watkins-Johnson L.P. antenna AR7-17A
 - Reference Sleeve-Dipole
14. Temperature Chamber
 - Thermotron, Model: S-8.0C
15. LISN
 - EMCO, Model: 3810/2NM, Line Impedance Stabilization Network
16. Antenna Positioning Mast / Turntable
 - Sunol Sciences Corp., Model: FM 2011, Turntable
 - Sunol Sciences Corp., Model: TLT95, Antenna Positioning Mast
 - Sunol Sciences Corp., Model: SC98V, System controller
 - Scientific Atlanta Antenna Analyzer System 2083A
17. Vector Network Analyzer
 - Anritsu MS4624B Vector Network Analyzer

18. Computers

- Dell, Laptop Computer
- Hitachi MX 166 computer, Hyperlink Terminal
- Dell Precision 420 Computer

19. Programming Cable

- RS232 Data Cable

20. Table

- Wood Table

21. RF Tray

- OATS RF Tray, Model 2000

22. Test Site

- OATS, Ground plane
- 60' Tapered Anechoic Chamber, Emerson & Cummings 1203