

FCC SAR Test Report

APPLICANT : Motorola Mobility LLC
EQUIPMENT : Mobile Cellular Phone
BRAND NAME : Motorola
MODEL NAME : XT2401-1
FCC ID : IHDT56AQ7
STANDARD : FCC 47 CFR Part 2 (2.1093)

We, Sporton International Inc. (Kunshan), would like to declare that the tested sample has been evaluated in accordance with the test procedures given in 47 CFR Part 2.1093 and FCC KDB and has been in compliance with the applicable technical standards.

The test results in this report apply exclusively to the tested model / sample. Without written approval of Sporton International Inc. (Kunshan), the test report shall not be reproduced except in full.



Approved by: Si Zhang

Sporton International Inc. (Kunshan)

**No. 1098, Pengxi North Road, Kunshan Economic Development Zone Jiangsu Province 215300
People's Republic of China**



Table of Contents

1. Statement of Compliance 4
2. Administration Data 6
3. Guidance Applied 6
4. Equipment Under Test (EUT) Information 7
4.1 General Information 7
4.2 General LTE SAR Test and Reporting Considerations 10
4.3 General 5G NR SAR Test and Reporting Considerations 14
5. Smart Transmit feature for RF Exposure compliance 17
6. Proximity Sensor Triggering Test 20
7. RF Exposure Limits 22
7.1 Uncontrolled Environment 22
7.2 Controlled Environment 22
8. Specific Absorption Rate (SAR) 23
8.1 Introduction 23
8.2 SAR Definition 23
9. System Description and Setup 24
9.1 E-Field Probe 25
9.2 Data Acquisition Electronics (DAE) 25
9.3 Phantom 26
9.4 Device Holder 27
10. Measurement Procedures 28
10.1 Spatial Peak SAR Evaluation 28
10.2 Power Reference Measurement 29
10.3 Area Scan 29
10.4 Zoom Scan 30
10.5 Volume Scan Procedures 30
10.6 Power Drift Monitoring 30
11. Test Equipment List 31
12. System Verification 32
12.1 Tissue Simulating Liquids 32
12.2 Tissue Verification 32
12.3 System Performance Check Results 34
13. RF Exposure Positions 36
13.1 Ear and handset reference point 36
13.2 Definition of the cheek position 37
13.3 Definition of the tilt position 38
13.4 Body Worn Accessory 39
13.5 Product Specific 10g SAR Exposure 40
13.6 Wireless Router 40
14. Conducted RF Output Power (Unit: dBm) 41
15. Antenna Location 58
16. SAR Test Results 59
16.1 Head SAR 62
16.2 Hotspot SAR 73
16.3 Body Worn Accessory SAR 86
16.4 Product specific 10g SAR 96
16.5 Repeated SAR Measurement 105
16.6 TDD 5G NR & LTE Linearity Data Analysis 106
17. Simultaneous Transmission Analysis 111
17.1 5G NR + LTE + WLAN + BT Sim-Tx analysis 112
17.2 Sub6 Antenna Groups 113
17.3 Head Exposure Conditions 114
17.4 Hotspot Exposure Conditions 116
17.5 Body-Worn Accessory Exposure Conditions 119
17.6 Product specific 10g SAR Exposure Conditions 122
17.7 SPLSR Evaluation and Analysis 125
17.8 Maximum Report SAR And SAR Peak Locations 139
18. Supplemental Tuner Tests Results 150
19. Uncertainty Assessment 151
20. References 152
Appendix A. Plots of System Performance Check
Appendix B. Plots of High SAR Measurement
Appendix C. DASY Calibration Certificate



1. Statement of Compliance

The maximum results of Specific Absorption Rate (SAR) found during testing for **Motorola Mobility LLC, Mobile Cellular Phone, XT2401-1**, are as follows.

Highest 1g SAR Summary						
Equipment Class	Frequency Band		Head (Separation 0mm)	Hotspot (Separation 5mm)	Body-worn (Separation 5mm)	Highest Simultaneous Transmission 1g SAR (W/kg)
			1g SAR (W/kg)			
Licensed	GSM	GSM850	1.19	1.20	1.20	1.59
		GSM1900	1.29	1.30	1.30	
	WCDMA	WCDMA II	1.30	1.28	1.28	
		WCDMA IV	1.29	1.31	1.27	
		WCDMA V	1.25	1.31	1.31	
	LTE	LTE Band 7	1.30	1.30	1.32	
		LTE Band 12/17	1.29	0.99	0.99	
		LTE Band 13	1.01	0.92	0.88	
		LTE Band 25/2	1.28	1.29	1.31	
		LTE Band 26/5	1.27	1.29	1.29	
		LTE Band 66/4	1.30	1.30	1.30	
		LTE Band 41/38	1.34	1.32	1.34	
	5G NR	LTE Band 42	1.31	1.30	1.20	
		FR1 n2	1.27	1.28	1.29	
		FR1 n7	1.29	1.30	1.29	
		FR1 n26/n5	1.10	0.90	0.90	
		FR1 n41/n38	1.28	1.29	1.29	
FR1 n66		1.29	1.29	1.30		
DTS	WLAN	FR1 n71	0.68	0.55	0.55	
		FR1 n77/n78	1.30	1.29	1.29	
NII	WLAN	2.4GHz WLAN	1.39	1.32	1.32	
DSS		5GHz WLAN	1.13	1.19	1.19	
DSS	Bluetooth	2.4GHz Bluetooth	0.41	0.74	0.74	

Highest 10g SAR Summary				
Equipment Class	Frequency Band		Product Specific 10g SAR (W/kg) (Separation 0mm)	Highest Simultaneous Transmission 10g SAR (W/kg)
Licensed	GSM	GSM1900	3.09	3.93
		WCDMA	WCDMA II	
	WCDMA IV		3.22	
	WCDMA V		1.60	
	LTE	LTE Band 7	3.31	
		LTE Band 25/2	3.24	
		LTE Band 26/5	1.89	
		LTE Band 66/4	3.27	
		LTE Band 41/38	3.24	
	5G NR	LTE Band 42	3.13	
		FR1 n2	3.19	
		FR1 n7	3.20	
FR1 n41/38		3.19		



		FR1 n66	3.26	
		FR1 n77/n78	3.17	
DTS	WLAN	2.4GHz WLAN	2.91	3.93
NII		5GHz WLAN	3.16	3.93
Date of Testing:			2024/2/26 ~ 2024/3/17	

Remark:

1. This device supports LTE B2 / B4 / B5 / B17 / B38 and B25 / B66 / B26 / B12 / B41. Since the supported frequency span for LTE B2 / B4 / B5 / B17 / B38 falls completely within the supports frequency span for LTE B25 / B66 / B26 / B12 / B41, both LTE bands have the same target power, and both LTE bands share the same transmission path; therefore, SAR was only assessed for LTE B25 / B66 / B26 / B12 / B41.
2. This device supports 5GNR n38/n5/n78 and n41/n26/n77. Since the supported frequency span for 5GNR n38/n5/n78 falls completely within the supports frequency span for n41/n26/n77, both 5GNR bands have the same target power, and both 5GNR bands share the same transmission path; therefore, SAR was only assessed for n41/n26/n77.

Declaration of Conformity:

The test results with all measurement uncertainty excluded are presented in accordance with the regulation limits or requirements declared by manufacturers.

Comments and Explanations:

The declared of product specification for EUT presented in the report are provided by the manufacturer, and the manufacturer takes all the responsibilities for the accuracy of product specification.

This device is in compliance with Specific Absorption Rate (SAR) for general population/uncontrolled exposure limits (1.6 W/kg for Partial-Body 1g SAR, 4.0 W/kg for Product Specific 10g SAR) specified in FCC 47 CFR part 2 (2.1093) and ANSI/IEEE C95.1-1992, and had been tested in accordance with the measurement methods and procedures specified in IEEE 1528-2013 and FCC KDB publications.



2. Administration Data

Sporton International Inc. (Kunshan) is accredited to ISO/IEC 17025:2017 by American Association for Laboratory Accreditation with Certificate Number 5145.02.

Testing Laboratory			
Test Firm	Sporton International Inc. (Kunshan)		
Test Site Location	No. 1098, Pengxi North Road, Kunshan Economic Development Zone Jiangsu Province 215300 People's Republic of China TEL : +86-512-57900158		
Test Site No.	Sporton Site No.	FCC Designation No.	FCC Test Firm Registration No.
	SAR06-KS SAR04-KS	CN1257	314309

Applicant	
Company Name	Motorola Mobility LLC
Address	222 W,Merchandise Mart Plaza, Chicago IL 60654 USA

Manufacturer	
Company Name	Motorola Mobility LLC
Address	222 W,Merchandise Mart Plaza, Chicago IL 60654 USA

3. Guidance Applied

The Specific Absorption Rate (SAR) testing specification, method, and procedure for this device is in accordance with the following standards:

- FCC 47 CFR Part 2 (2.1093)
- ANSI/IEEE C95.1-1992
- IEEE 1528-2013
- FCC KDB 865664 D01 SAR Measurement 100 MHz to 6 GHz v01r04
- FCC KDB 865664 D02 SAR Reporting v01r02
- FCC KDB 447498 D01 General RF Exposure Guidance v06
- FCC KDB 648474 D04 SAR Evaluation Considerations for Wireless Handsets v01r03
- FCC KDB 248227 D01 802.11 Wi-Fi SAR v02r02
- FCC KDB 616217 D04 SAR for laptop and tablets v01r02
- FCC KDB 941225 D01 3G SAR Procedures v03r01
- FCC KDB 941225 D05 SAR for LTE Devices v02r05
- FCC KDB 941225 D05A Rel.10 LTE SAR Test Guidance v01r02
- FCC KDB 941225 D06 Hotspot Mode SAR v02r01



4. Equipment Under Test (EUT) Information

4.1 General Information

Product Feature & Specification	
Equipment Name	Mobile Cellular Phone
Brand Name	Motorola
Model Name	XT2401-1
FCC ID	IHDT56AQ7
IMEI Code	Sample 1 IMEI1: 357505570025392 IMEI2: 357505570025400 Sample 2 IMEI1: 357505570038635 IMEI2: 357505570038643
Wireless Technology and Frequency Range	GSM850: 824 MHz ~ 849 MHz GSM1900: 1850 MHz ~ 1910 MHz WCDMA Band II: 1850 MHz ~ 1910 MHz WCDMA Band IV: 1710 MHz ~ 1755 MHz WCDMA Band V: 824 MHz ~ 849 MHz LTE Band 2: 1850 MHz ~ 1910 MHz LTE Band 4: 1710 MHz ~ 1755 MHz LTE Band 5: 824 MHz ~ 849 MHz LTE Band 7: 2500 MHz ~ 2570 MHz LTE Band 12: 699 MHz ~ 716 MHz LTE Band 13: 777 MHz ~ 787 MHz LTE Band 17: 704 MHz ~ 716 MHz LTE Band 25: 1850 MHz ~ 1915 MHz LTE Band 26: 814 MHz ~ 849 MHz LTE Band 38: 2570 MHz ~ 2620 MHz LTE Band 41: 2496 MHz ~ 2690 MHz LTE Band 42: 3450 MHz ~ 3550 MHz LTE Band 66: 1710 MHz ~ 1780 MHz 5G NR n2: 1850 MHz ~ 1910 MHz 5G NR n5: 824 MHz ~ 849 MHz 5G NR n7: 2500 MHz ~ 2570 MHz 5G NR n26: 814 MHz ~ 849 MHz 5G NR n38: 2570 MHz ~ 2620 MHz 5G NR n41: 2496 MHz ~ 2690 MHz 5G NR n66: 1710 MHz ~ 1780 MHz 5G NR n71 : 663 MHz ~ 698 MHz 5G NR n77: 3700 MHz ~ 3980 MHz 5G NR n78: 3700 MHz ~ 3800 MHz WLAN 2.4GHz Band: 2412 MHz ~ 2462 MHz WLAN 5.2GHz Band: 5180 MHz ~ 5240 MHz WLAN 5.3GHz Band: 5260 MHz ~ 5320 MHz WLAN 5.5GHz Band: 5500 MHz ~ 5720 MHz WLAN 5.8GHz Band: 5745 MHz ~ 5825 MHz WLAN 6GHz U-NII-5: 5925 MHz ~ 6425 MHz WLAN 6GHz U-NII-6: 6425 MHz ~ 6525 MHz WLAN 6GHz U-NII-7: 6525 MHz ~ 6875 MHz WLAN 6GHz U-NII-8: 6875 MHz ~ 7125 MHz Bluetooth: 2402 MHz ~ 2480 MHz NFC: 13.56 MHz WPT: 110 kHz ~ 148 kHz UWB: 6489.6MHz & 7987.2MHz
Mode	GSM/GPRS/EGPRS RMC/AMR 12.2Kbps HSDPA HSUPA DC-HSDPA



	HSPA+(16QAM uplink is not supported) LTE: QPSK, 16QAM, 64QAM, 256QAM 5G NR : CP-OFDM / DFT-s-OFDM, PI/2 BPSK, QPSK, 16QAM, 64QAM, 256QAM WLAN 2.4GHz 802.11b/g/n HT20/HT40 WLAN 2.4GHz 802.11ax HE20/HE40 WLAN 2.4GHz 802.11be EHT20/EHT40 WLAN 5GHz 802.11a/n HT20/HT40 WLAN 5GHz 802.11ac/ax VHT20/VHT40/VHT80/VHT160/HE20/HE40/HE80/HE160 WLAN 5GHz 802.11be EHT20/EHT40/EHT80/EHT160 WLAN 6GHz 802.11a/ax HE20/HE40/HE80/HE160 WLAN 6GHz 802.11be EHT20/EHT40/EHT80/EHT160/EHT320 Bluetooth BR/EDR/LE NFC: ASK WPT: ASK UWB: BPM-BPSK
HW Version	DVT2
SW Version	UUV34.71
GSM / (E)GPRS Transfer mode	Class B – EUT cannot support Packet Switched and Circuit Switched Network simultaneously but can automatically switch between Packet and Circuit Switched Network.
EUT Stage	Identical Prototype
Remark:	
<ol style="list-style-type: none"> 1. This device supports VoIP in GPRS, EGPRS, WCDMA, LTE and 5G NR (e.g. for 3rd-party VoIP), LTE supports VoLTE operation. 2. This device 2.4GHz WLAN support hotspot operation and Bluetooth support tethering applications. 3. This device 5.2GHz WLAN/5.8GHz WLAN support hotspot operation, and 5.2GHz WLAN/5.8GHz WLAN supports WiFi Direct (GC/GO), and 5.3GHz / 5.5GHz supports WiFi Direct (GC only). 4. This device does not support DTM operation and supports GPRS/EGPRS mode up to multi-slot class 12. 5. The 2.4GHz/5GHz/6GHz WLAN can transmit in MIMO antenna mode only. 6. For dual SIM card mobile has single SIM slots + eSIM (electronic SIM) and supports dual SIM dual standby. The WWAN radio transmission will be enabled by either one SIM at a time (single active). 7. The device implements the power management and proximity sensor /receiver detection/hotspot mode for SAR compliance at different exposure conditions (head, body-worn, hotspot, extremity) and the Qualcomm smart transmit will manage to ensure the power level not exceeding the associated power table. Details about the power management decision and sensor detection are provided in the operational description. And the device will invoke corresponding work scenarios power level base on frequency bands/antennas, which can refer to power table at appendix E. 8. This device implements antenna tuning techniques for several WWAN (cellular) operating modes and frequencies for the purpose of improving antenna efficiency over a broad range of frequencies. Specifically, these techniques are employed in the LTE and 5G NR modes. In this report SAR was measured according to the normally required SAR configurations with the tuner active and worst tune state (auto tune) was used for SAR testing. The detail descriptions of the antenna tuner and supplemental data for additional information can be referred to section 18 and appendix F. 9. LTE Band 41 and 5G NR n77/n78 supports HPUE, HPUE power and SAR testing performed separately. 10. LTE Band 41 and 5G NR n77/n78 HPUE with higher power, For HPUE power is higher than power class 3 but with lower duty cycle, the maximum average power for class 2 and class 3 is almost the same, so we chose power class 3 full SAR testing and power class 2 verified the worst case of power class 3 SAR. 11. For 5G NR n77/n78 HPUE, 5G NR n77/n78 PC2 Maximum Duty Cycle is 50%, using FTM (Factory Test Mode) with 50% duty cycle is considered during SAR testing. For 5G NR other bands, using FTM to perform SAR with default 100% transmission. 12. 5G NR n41 supports UL MIMO. 13. The UWB output power is -12.4dBm and it is less than 1mW and exempt from power density testing. 14. There are two samples, the different between them refer to the XT2401-1_Operational Description of Product Equality Declaration which is exhibit separately. According to the differences, so choose sample 1 to perform full SAR testing and sample 2 to verify the worst case of sample 1. 15. This device has NFC function and the NFC SAR report will be separately submitted. 16. RF exposure report for WPC (Wireless power charging) will be separately submitted. 17. SAR and Power density test report for WLAN 6GHz U-NII-5/6/7/8 will be separately submitted. About co-located SAR with WWAN/Bluetooth always chose higher SAR of WLAN5GHz U-NII-1/2A/2C/3 and WLAN 6GHz U-NII-5/6/7/8. 18. This device supports 5G NR FR1 bands as following table, including NSA mode and SA mode. NSA and SA mode performed SAR separately. 	

<5G NR>

Mode	Band	Duplex	SCS(KHz)	Bandwidths(BW)
NSA	n2	FDD	15	5, 10, 15, 20, 25, 30, 35, 40
	n5	FDD	15	5, 10, 15, 20
	n7	FDD	15	5, 10, 15, 20, 25, 30, 40
	n26	FDD	15	5, 10, 15, 20
	n66	FDD	15	5, 10, 15, 20, 25, 30, 35, 40
	n38	TDD	30	10, 15, 20, 25, 30, 40
	n41	TDD	30	10, 15, 20, 25, 30, 40, 50, 60, 70, 80, 90, 100
	n77	TDD	30	10, 15, 20, 25, 30, 40, 50, 60, 70, 80, 90, 100
SA	n78	TDD	30	10, 15, 20, 25, 30, 40, 50, 60, 70, 80, 90, 100
	n2	FDD	15	5, 10, 15, 20, 25, 30, 35, 40
	n5	FDD	15	5, 10, 15, 20
	n7	FDD	15	5, 10, 15, 20, 25, 30, 40
	n26	FDD	15	5, 10, 15, 20
	n66	FDD	15	5, 10, 15, 20, 25, 30, 35, 40
	n71	FDD	15	5, 10, 15, 20
	n38	TDD	30	10, 15, 20, 25, 30, 40
	n41	TDD	30	10, 15, 20, 25, 30, 40, 50, 60, 70, 80, 90, 100
	n77	TDD	30	10, 15, 20, 25, 30, 40, 50, 60, 70, 80, 90, 100
n78	TDD	30	10, 15, 20, 25, 30, 40, 50, 60, 70, 80, 90, 100	



4.2 General LTE SAR Test and Reporting Considerations

Summarized necessary items addressed in KDB 941225 D05 v02r05																																																															
FCC ID	IHDT56AQ7																																																														
Equipment Name	Mobile Cellular Phone																																																														
Operating Frequency Range of each LTE transmission band	LTE Band 2: 1850 MHz ~ 1910 MHz LTE Band 4: 1710 MHz ~ 1755 MHz LTE Band 5: 824 MHz ~ 849 MHz LTE Band 7: 2500 MHz ~ 2570 MHz LTE Band 12: 699 MHz ~ 716 MHz LTE Band 13: 777 MHz ~ 787 MHz LTE Band 17: 704 MHz ~ 716 MHz LTE Band 25: 1850 MHz ~ 1915 MHz LTE Band 26: 814 MHz ~ 849 MHz LTE Band 38: 2570 MHz ~ 2620 MHz LTE Band 41: 2496 MHz ~ 2690 MHz LTE Band 42: 3450 MHz ~ 3550 MHz LTE Band 66: 1710 MHz ~ 1780 MHz																																																														
Channel Bandwidth	LTE Band 2: 1.4MHz, 3MHz, 5MHz, 10MHz, 15MHz, 20MHz LTE Band 4: 1.4MHz, 3MHz, 5MHz, 10MHz, 15MHz, 20MHz LTE Band 5: 1.4MHz, 3MHz, 5MHz, 10MHz LTE Band 7: 5MHz, 10MHz, 15MHz, 20MHz LTE Band 12: 1.4MHz, 3MHz, 5MHz, 10MHz LTE Band 13: 5MHz, 10MHz LTE Band 17: 5MHz, 10MHz LTE Band 25: 1.4MHz, 3MHz, 5MHz, 10MHz, 15MHz, 20MHz LTE Band 26: 1.4MHz, 3MHz, 5MHz, 10MHz, 15MHz LTE Band 38: 5MHz, 10MHz, 15MHz, 20MHz LTE Band 41: 5MHz, 10MHz, 15MHz, 20MHz LTE Band 42: 5MHz, 10MHz, 15MHz, 20MHz LTE Band 66: 1.4MHz, 3MHz, 5MHz, 10MHz, 15MHz, 20MHz																																																														
uplink modulations used	QPSK / 16QAM / 64QAM / 256QAM																																																														
LTE Voice / Data requirements	Voice and Data																																																														
LTE Release Version	R17, Cat18																																																														
CA Support	Supported, Uplink and Downlink																																																														
LTE MPR permanently built-in by design	<p>Table 6.2.3-1: Maximum Power Reduction (MPR) for Power Class 1, 2 and 3</p> <table border="1"> <thead> <tr> <th rowspan="2">Modulation</th> <th colspan="6">Channel bandwidth / Transmission bandwidth (N_{RB})</th> <th rowspan="2">MPR (dB)</th> </tr> <tr> <th>1.4 MHz</th> <th>3.0 MHz</th> <th>5 MHz</th> <th>10 MHz</th> <th>15 MHz</th> <th>20 MHz</th> </tr> </thead> <tbody> <tr> <td>QPSK</td> <td>> 5</td> <td>> 4</td> <td>> 8</td> <td>> 12</td> <td>> 16</td> <td>> 18</td> <td>≤ 1</td> </tr> <tr> <td>16 QAM</td> <td>≤ 5</td> <td>≤ 4</td> <td>≤ 8</td> <td>≤ 12</td> <td>≤ 16</td> <td>≤ 18</td> <td>≤ 1</td> </tr> <tr> <td>16 QAM</td> <td>> 5</td> <td>> 4</td> <td>> 8</td> <td>> 12</td> <td>> 16</td> <td>> 18</td> <td>≤ 2</td> </tr> <tr> <td>64 QAM</td> <td>≤ 5</td> <td>≤ 4</td> <td>≤ 8</td> <td>≤ 12</td> <td>≤ 16</td> <td>≤ 18</td> <td>≤ 2</td> </tr> <tr> <td>64 QAM</td> <td>> 5</td> <td>> 4</td> <td>> 8</td> <td>> 12</td> <td>> 16</td> <td>> 18</td> <td>≤ 3</td> </tr> <tr> <td>256 QAM</td> <td colspan="6" style="text-align: center;">≥ 1</td> <td>≤ 5</td> </tr> </tbody> </table>	Modulation	Channel bandwidth / Transmission bandwidth (N_{RB})						MPR (dB)	1.4 MHz	3.0 MHz	5 MHz	10 MHz	15 MHz	20 MHz	QPSK	> 5	> 4	> 8	> 12	> 16	> 18	≤ 1	16 QAM	≤ 5	≤ 4	≤ 8	≤ 12	≤ 16	≤ 18	≤ 1	16 QAM	> 5	> 4	> 8	> 12	> 16	> 18	≤ 2	64 QAM	≤ 5	≤ 4	≤ 8	≤ 12	≤ 16	≤ 18	≤ 2	64 QAM	> 5	> 4	> 8	> 12	> 16	> 18	≤ 3	256 QAM	≥ 1						≤ 5
Modulation	Channel bandwidth / Transmission bandwidth (N_{RB})						MPR (dB)																																																								
	1.4 MHz	3.0 MHz	5 MHz	10 MHz	15 MHz	20 MHz																																																									
QPSK	> 5	> 4	> 8	> 12	> 16	> 18	≤ 1																																																								
16 QAM	≤ 5	≤ 4	≤ 8	≤ 12	≤ 16	≤ 18	≤ 1																																																								
16 QAM	> 5	> 4	> 8	> 12	> 16	> 18	≤ 2																																																								
64 QAM	≤ 5	≤ 4	≤ 8	≤ 12	≤ 16	≤ 18	≤ 2																																																								
64 QAM	> 5	> 4	> 8	> 12	> 16	> 18	≤ 3																																																								
256 QAM	≥ 1						≤ 5																																																								
LTE A-MPR	In the base station simulator configuration, Network Setting value is set to NS_01 to disable A-MPR during SAR testing and the LTE SAR tests was transmitting on all TTI frames (Maximum TTI)																																																														
Spectrum plots for RB configuration	A properly configured base station simulator was used for the SAR and power measurement; therefore, spectrum plots for each RB allocation and offset configuration are not included in the SAR report.																																																														
Power reduction applied to satisfy SAR compliance	Yes, when operating in Proximity sensors/receiver/hotspot detect mechanism, head/body -worn /hotspot/extremity will trigger reduced power for some bands applied to satisfy SAR compliance, the detail please referred to section 14.																																																														
LTE Carrier Aggregation Combinations	Inter-Band and Intra-Band possible combinations and the detail power verification please referred to section 14.																																																														
LTE Carrier Aggregation Additional Information	1. This device supports LTE Carrier Aggregation (CA) in the uplink for intra-band and inter-band with two component carriers in the uplink. SAR Measurements and conducted powers were evaluated per FCC Guidance. 2. This device supports maximum of 5 carriers in the downlink and 2 carriers in the uplink.																																																														



Transmission (H, M, L) channel numbers and frequencies in each LTE band												
LTE Band 2												
	Bandwidth 1.4 MHz		Bandwidth 3 MHz		Bandwidth 5 MHz		Bandwidth 10 MHz		Bandwidth 15 MHz		Bandwidth 20 MHz	
	Ch. #	Freq. (MHz)	Ch. #	Freq. (MHz)	Ch. #	Freq. (MHz)	Ch. #	Freq. (MHz)	Ch. #	Freq. (MHz)	Ch. #	Freq. (MHz)
L	18607	1850.7	18615	1851.5	18625	1852.5	18650	1855	18675	1857.5	18700	1860
M	18900	1880	18900	1880	18900	1880	18900	1880	18900	1880	18900	1880
H	19193	1909.3	19185	1908.5	19175	1907.5	19150	1905	19125	1902.5	19100	1900
LTE Band 4												
	Bandwidth 1.4 MHz		Bandwidth 3 MHz		Bandwidth 5 MHz		Bandwidth 10 MHz		Bandwidth 15 MHz		Bandwidth 20 MHz	
	Ch. #	Freq. (MHz)	Ch. #	Freq. (MHz)	Ch. #	Freq. (MHz)	Ch. #	Freq. (MHz)	Ch. #	Freq. (MHz)	Ch. #	Freq. (MHz)
L	19957	1710.7	19965	1711.5	19975	1712.5	20000	1715	20025	1717.5	20050	1720
M	20175	1732.5	20175	1732.5	20175	1732.5	20175	1732.5	20175	1732.5	20175	1732.5
H	20393	1754.3	20385	1753.5	20375	1752.5	20350	1750	20325	1747.5	20300	1745
LTE Band 5												
	Bandwidth 1.4 MHz		Bandwidth 3 MHz		Bandwidth 5 MHz		Bandwidth 10 MHz					
	Ch. #	Freq. (MHz)	Ch. #	Freq. (MHz)	Ch. #	Freq. (MHz)	Ch. #	Freq. (MHz)	Ch. #	Freq. (MHz)	Ch. #	Freq. (MHz)
L	20407	824.7	20415	825.5	20425	826.5	20450	829				
M	20525	836.5	20525	836.5	20525	836.5	20525	836.5	20525	836.5	20525	836.5
H	20643	848.3	20635	847.5	20625	846.5	20600	844				
LTE Band 7												
	Bandwidth 5 MHz		Bandwidth 10 MHz		Bandwidth 15 MHz		Bandwidth 20 MHz					
	Ch. #	Freq. (MHz)	Ch. #	Freq. (MHz)	Ch. #	Freq. (MHz)	Ch. #	Freq. (MHz)	Ch. #	Freq. (MHz)	Ch. #	Freq. (MHz)
L	20775	2502.5	20800	2505	20825	2507.5	20850	2510				
M	21100	2535	21100	2535	21100	2535	21100	2535				
H	21425	2567.5	21400	2565	21375	2562.5	21350	2560				
LTE Band 12												
	Bandwidth 1.4 MHz		Bandwidth 3 MHz		Bandwidth 5 MHz		Bandwidth 10 MHz					
	Ch. #	Freq. (MHz)	Ch. #	Freq. (MHz)	Ch. #	Freq. (MHz)	Ch. #	Freq. (MHz)	Ch. #	Freq. (MHz)	Ch. #	Freq. (MHz)
L	23017	699.7	23025	700.5	23035	701.5	23060	704				
M	23095	707.5	23095	707.5	23095	707.5	23095	707.5				
H	23173	715.3	23165	714.5	23155	713.5	23130	711				
LTE Band 13												
	Bandwidth 5 MHz				Bandwidth 10 MHz							
	Channel #		Freq.(MHz)		Channel #		Freq.(MHz)		Channel #		Freq.(MHz)	
L	23205		779.5		23230		782					
M	23230		782									
H	23255		784.5									
LTE Band 17												
	Bandwidth 5 MHz				Bandwidth 10 MHz							
	Channel #		Freq.(MHz)		Channel #		Freq. (MHz)		Channel #		Freq. (MHz)	
L	23755		706.5		23780		709					
M	23790		710		23790		710					
H	23825		713.5		23800		711					
LTE Band 25												
	Bandwidth 1.4 MHz		Bandwidth 3 MHz		Bandwidth 5 MHz		Bandwidth 10 MHz		Bandwidth 15 MHz		Bandwidth 20 MHz	
	Ch. #	Freq. (MHz)	Ch. #	Freq. (MHz)	Ch. #	Freq. (MHz)	Ch. #	Freq. (MHz)	Ch. #	Freq. (MHz)	Ch. #	Freq. (MHz)
L	26047	1850.7	26055	1851.5	26065	1852.5	26090	1855	26115	1857.5	26140	1860
M	26340	1880	26340	1880	26340	1880	26340	1880	26340	1880	26340	1880
H	26683	1914.3	26675	1913.5	26665	1912.5	26640	1910	26615	1907.5	26590	1905
LTE Band 26												
	Bandwidth 1.4 MHz		Bandwidth 3 MHz		Bandwidth 5 MHz		Bandwidth 10 MHz		Bandwidth 15 MHz			
	Ch. #	Freq. (MHz)	Ch. #	Freq. (MHz)	Ch. #	Freq. (MHz)	Ch. #	Freq. (MHz)	Ch. #	Freq. (MHz)	Ch. #	Freq. (MHz)
L	26697	814.7	26705	815.5	26715	816.5	26740	819	26765	821.5		
M	26865	831.5	26865	831.5	26865	831.5	26865	831.5	26865	831.5	26865	831.5
H	27033	848.3	27025	847.5	27015	846.5	26990	844	26965	841.5		
LTE Band 38												
	Bandwidth 5 MHz		Bandwidth 10 MHz		Bandwidth 15 MHz		Bandwidth 20 MHz					
	Ch. #	Freq. (MHz)	Ch. #	Freq. (MHz)	Ch. #	Freq. (MHz)	Ch. #	Freq. (MHz)	Ch. #	Freq. (MHz)	Ch. #	Freq. (MHz)
L	37775	2572.5	37800	2575	37825	2577.5	37850	2580				
M	38000	2595	38000	2595	38000	2595	38000	2595				
H	38225	2617.5	38200	2615	38175	2612.5	38150	2610				
LTE Band 41												



	Bandwidth 5 MHz		Bandwidth 10 MHz		Bandwidth 15 MHz		Bandwidth 20 MHz					
	Ch. #	Freq. (MHz)	Ch. #	Freq. (MHz)	Ch. #	Freq. (MHz)	Ch. #	Freq. (MHz)				
L	39675	2498.5	39700	2501	39725	2503.5	39750	2506				
LM	40148	2545.8	40160	2547	40173	2548.3	40185	2549.5				
M	40620	2593	40620	2593	40620	2593	40620	2593				
HM	41093	2640.3	41080	2639	41068	2637.8	41055	2636.5				
H	41565	2687.5	41540	2685	41515	2682.5	41490	2680				
LTE Band 66												
	Bandwidth 1.4 MHz		Bandwidth 3 MHz		Bandwidth 5 MHz		Bandwidth 10 MHz		Bandwidth 15 MHz		Bandwidth 20 MHz	
	Ch. #	Freq. (MHz)	Ch. #	Freq. (MHz)	Ch. #	Freq. (MHz)	Ch. #	Freq. (MHz)	Ch. #	Freq. (MHz)	Ch. #	Freq. (MHz)
L	131979	1710.7	131987	1711.5	131997	1712.5	132022	1715	132047	1717.5	132072	1720
M	132322	1745	132322	1745	132322	1745	132322	1745	132322	1745	132322	1745
H	132665	1779.3	132657	1778.5	132647	1777.5	132622	1775	132597	1772.5	132572	1770
LTE Band 42												
	Bandwidth 5 MHz		Bandwidth 10 MHz		Bandwidth 15 MHz		Bandwidth 20 MHz					
	Ch. #	Freq. (MHz)	Ch. #	Freq. (MHz)	Ch. #	Freq. (MHz)	Ch. #	Freq. (MHz)				
L	42115	3452.5	42140	3455	42165	3457.5	42190	3460				
M	42590	3500	42590	3500	42590	3500	42590	3500				
H	43065	3547.5	43040	3545	43015	3542.5	42990	3540				

<For LTE Overlap Bands Description>

1) LTE Bands BW

Band	1.4 MHz	3 MHz	5 MHz	10 MHz	15 MHz	20 MHz
LTE Band 12	Yes	Yes	Yes	Yes		
LTE Band 17			Yes	Yes		
LTE Band 5	Yes	Yes	Yes	Yes		
LTE Band 26	Yes	Yes	Yes	Yes	Yes	
LTE Band 2	Yes	Yes	Yes	Yes	Yes	Yes
LTE Band 25	Yes	Yes	Yes	Yes	Yes	Yes
LTE Band 4	Yes	Yes	Yes	Yes	Yes	Yes
LTE Band 66	Yes	Yes	Yes	Yes	Yes	Yes
LTE Band 38			Yes	Yes	Yes	Yes
LTE Band 41			Yes	Yes	Yes	Yes

2) LTE Bands tune up:

Band	Antenna	Head	Body-worn	Hotspot	Extremity	Sensor Off	Default
		DSI 2 Tune-up Limit	DSI 3 Tune-up Limit	DSI 7 Tune-up Limit	DSI 6 Tune-up Limit	DSI4 Tune-up Limit	Tune-up Limit
LTE Band 12	Ant 0	24	24	24	24	24	24
LTE Band 17	Ant 0	24	24	24	24	24	24
LTE Band 12	Ant 1	23.4	24	24	24	24	24
LTE Band 17	Ant 1	23.4	24	24	24	24	24
LTE Band 5	Ant 0	24	24	24	24	24	24
LTE Band 26	Ant 0	24	24	24	24	24	24
LTE Band 5	Ant 1	23.5	23.4	23.4	24	24	24
LTE Band 26	Ant 1	23.5	23.4	23.4	24	24	24
LTE Band 2	Ant 2	24	21.1	19.5	22.2	24	24
LTE Band 25	Ant 2	24	21.1	19.5	22.2	24	24



LTE Band 2	Ant 1	17.4	17.5	17.5	19.5	24	24
LTE Band 25	Ant 1	17.4	17.5	17.5	19.5	24	24
LTE Band 2 Other PA	Ant 1	17.4	17.5	17.5	19.5	24	24
LTE Band 4	Ant 2	24	20	18.9	22	24	24
LTE Band 66	Ant 2	24	20	18.9	22	24	24
LTE Band 4	Ant 1	18.2	18.6	18.6	20.4	24	24
LTE Band 66	Ant 1	18.2	18.6	18.6	20.4	24	24
LTE Band 4 Other PA	Ant 1	18.2	18.6	18.6	20.4	24	24
LTE Band 66 Other PA	Ant 1	18.2	18.6	18.6	20.4	24	24
LTE Band 38	Ant 2	24	22.3	21.7	22.8	24	24
LTE Band 41	Ant 2	24	22.3	21.7	22.8	24	24
LTE Band 41 HPUE	Ant 2	27	23.9	23.3	24.4	27	27
LTE Band 38	Ant 1	20	22.6	19	23	24	24
LTE Band 41	Ant 1	20	22.6	19	23	24	24
LTE Band 41 HPUE	Ant 1	21.6	24.2	20.6	24.6	27	27
LTE Band 38 Other PA	Ant 1	20	22.6	19	23	24	24
LTE Band 41 Other PA	Ant 1	20	22.6	19	23	24	24
LTE Band 41 HPUE Other PA	Ant 1	21.6	24.2	20.6	24.6	27	27
LTE Band 38	Ant 0	24	23.8	21.5	24	24	24
LTE Band 41	Ant 0	24	23.8	21.5	24	24	24
LTE Band 41 HPUE	Ant 0	27	25.4	23.1	26.2	27	27
LTE Band 38	Ant 3	19.9	23	19.5	23	23	23
LTE Band 41	Ant 3	19.9	23	19.5	23	23	23
LTE Band 41 HPUE	Ant 3	21.5	26	21.1	25.5	26	26

4.3 General 5G NR SAR Test and Reporting Considerations

5G NR Information	
Operating Frequency Range of each 5G NR transmission band	5G NR n2: 1850 MHz ~ 1910 MHz 5G NR n5: 824 MHz ~ 849 MHz 5G NR n7: 2500 MHz ~ 2570 MHz 5G NR n26: 814 MHz ~ 849 MHz 5G NR n38: 2570 MHz ~ 2620 MHz 5G NR n41: 2496 MHz ~ 2690 MHz 5G NR n66: 1710 MHz ~ 1780 MHz 5G NR n71: 663 MHz ~ 698 MHz 5G NR n77: 3700 MHz ~ 3980 MHz 5G NR n78: 3700 MHz ~ 3800 MHz
Channel Bandwidth	The detail please refers to section 4.1 5GNR FR1 bands table.
SCS	FDD: SCS15KHz, TDD: SCS30KHz
uplink modulations used	DFT-s-OFDM: PI/2 BPSK / QPSK / 16QAM / 64QAM / 256QAM CP-OFDM: QPSK / 16QAM / 64QAM / 256QAM
A-MPR (Additional MPR) disabled for SAR Testing?	Yes
LTE Anchor Bands for n2	LTE B4/66
LTE Anchor Bands for n5	LTE B7/66
LTE Anchor Bands for n7	LTE B2/4/5/66
LTE Anchor Bands for n26	LTE B7
LTE Anchor Bands for n38	LTE B4/66
LTE Anchor Bands for n41	LTE B4/5/66
LTE Anchor Bands for n66	LTE B2/5/7/13
LTE Anchor Bands for n77	LTE B7/41
LTE Anchor Bands for n78	LTE B2/4/5/7/26/38/41/66

Transmission (H, M, L) channel numbers and frequencies in each 5G NR band																
NR Band 2																
	Bandwidth 5MHz		Bandwidth 10MHz		Bandwidth 15MHz		Bandwidth 20MHz		Bandwidth 25MHz		Bandwidth 30MHz		Bandwidth 35MHz		Bandwidth 40MHz	
	Ch. #	Freq. (MHz)	Ch. #	Freq. (MHz)	Ch. #	Freq. (MHz)	Ch. #	Freq. (MHz)	Ch. #	Freq. (MHz)	Ch. #	Freq. (MHz)	Ch. #	Freq. (MHz)	Ch. #	Freq. (MHz)
L	370500	1852.5	371000	1855	371500	1857.5	372000	1860	372500	1862.5	373000	1865	373500	1867.5	374000	1870
M	376000	1880	376000	1880	376000	1880	376000	1880	376000	1880	376000	1880	376000	1880	376000	1880
H	381500	1907.5	381000	1905	380500	1902.5	380000	1900	379500	1897.5	379000	1895	378500	1892.5	378000	1890

NR Band 5										
	Bandwidth 5MHz		Bandwidth 10MHz		Bandwidth 15MHz		Bandwidth 20MHz			
	Ch. #	Freq. (MHz)	Ch. #	Freq. (MHz)	Ch. #	Freq. (MHz)	Ch. #	Freq. (MHz)	Ch. #	Freq. (MHz)
L	165300	826.5	165800	829	166300	831.5	166800	834		
M	167300	836.5	167300	836.5	167300	836.5	167300	836.5		
H	169300	846.5	168800	844	168300	841.5	167800	839		

NR Band 7														
	Bandwidth 5MHz		Bandwidth 10MHz		Bandwidth 15MHz		Bandwidth 20MHz		Bandwidth 25MHz		Bandwidth 30MHz		Bandwidth 40MHz	
	Ch. #	Freq. (MHz)	Ch. #	Freq. (MHz)	Ch. #	Freq. (MHz)	Ch. #	Freq. (MHz)	Ch. #	Freq. (MHz)	Ch. #	Freq. (MHz)	Ch. #	Freq. (MHz)
L	500500	2502.5	501000	2505	501500	2507.5	502000	2510	502500	2512.5	503000	2515	504000	2520
M	507000	2535	507000	2535	507000	2535	507000	2535	507000	2535	507000	2535	507000	2535
H	513500	2567.5	513000	2565	512500	2562.5	512000	2560	511500	2557.5	511000	2555	510000	2550

NR Band 26										
	Bandwidth 5MHz		Bandwidth 10MHz		Bandwidth 15MHz		Bandwidth 20MHz			
	Ch. #	Freq. (MHz)	Ch. #	Freq. (MHz)	Ch. #	Freq. (MHz)	Ch. #	Freq. (MHz)	Ch. #	Freq. (MHz)
L	163300	816.5	163800	819	164300	821.5	164800	824		
M	166300	831.5	166300	831.5	166300	831.5	166300	831.5		
H	169300	846.5	168800	844	168300	841.5	167800	839		

NR Band 66																
	Bandwidth 5MHz		Bandwidth 10MHz		Bandwidth 15MHz		Bandwidth 20MHz		Bandwidth 25MHz		Bandwidth 30MHz		Bandwidth 35MHz		Bandwidth 40MHz	
	Ch. #	Freq. (MHz)	Ch. #	Freq. (MHz)	Ch. #	Freq. (MHz)	Ch. #	Freq. (MHz)	Ch. #	Freq. (MHz)	Ch. #	Freq. (MHz)	Ch. #	Freq. (MHz)	Ch. #	Freq. (MHz)
L	342500	1712.5	343000	1715	343500	1717.5	344000	1720	344500	1722.5	345000	1725	345500	1727.5	346000	1730
M	349000	1745	349000	1745	349000	1745	349000	1745	349000	1745	349000	1745	349000	1745	349000	1745
H	355500	1777.5	355000	1775	354500	1772.5	354000	1770	353500	1767.5	353000	1765	352500	1762.5	352000	1760



NR Band 71								
	Bandwidth 5MHz		Bandwidth 10MHz		Bandwidth 15MHz		Bandwidth 20MHz	
	Ch. #	Freq. (MHz)	Ch. #	Freq. (MHz)	Ch. #	Freq. (MHz)	Ch. #	Freq. (MHz)
L	133100	665.5	133600	668	134100	670.5	134600	673
M	136100	680.5	136100	680.5	136100	680.5	136100	680.5
H	139100	695.5	138600	693	138100	690.5	137600	688

NR Band 38												
	Bandwidth 10MHz		Bandwidth 15MHz		Bandwidth 20MHz		Bandwidth 25MHz		Bandwidth 30MHz		Bandwidth 40MHz	
	Ch. #	Freq. (MHz)	Ch. #	Freq. (MHz)	Ch. #	Freq. (MHz)	Ch. #	Freq. (MHz)	Ch. #	Freq. (MHz)	Ch. #	Freq. (MHz)
L	515004	2575.02	515502	2577.51	516000	2580	516504	2582.52	517002	2585.01	518004	2590.02
M	519000	2595	519000	2595	519000	2595	519000	2595	519000	2595	519000	2595
H	522996	2614.98	522498	2612.49	522000	2610	521496	2607.48	520998	2604.99	519996	2599.98

NR Band 41																								
Bandwidth 10MHz		Bandwidth 15MHz		Bandwidth 20MHz		Bandwidth 25MHz		Bandwidth 30MHz		Bandwidth 40MHz		Bandwidth 50MHz		Bandwidth 60MHz		Bandwidth 70MHz		Bandwidth 80MHz		Bandwidth 90MHz		Bandwidth 100MHz		
Ch. #	Freq. (MHz)	Ch. #	Freq. (MHz)	Ch. #	Freq. (MHz)	Ch. #	Freq. (MHz)	Ch. #	Freq. (MHz)	Ch. #	Freq. (MHz)	Ch. #	Freq. (MHz)	Ch. #	Freq. (MHz)	Ch. #	Freq. (MHz)	Ch. #	Freq. (MHz)	Ch. #	Freq. (MHz)	Ch. #	Freq. (MHz)	
L	500202	2501.01	500700	2503.5	501204	2506.02	501702	2508.51	502200	2511	503202	2516.01	504204	2521.02	505200	2526	500202	2501.01	507204	2536.02	508200	2541	509202	2546.01
M	518598	2592.99	518598	2592.99	518598	2592.99	518598	2592.99	518598	2592.99	518598	2592.99	518598	2592.99	518598	2592.99	518598	2592.99	518598	2592.99	518598	2592.99	518598	2592.99
H	537000	2685	536496	2682.48	535998	2679.99	535500	2677.5	534996	2674.98	534000	2670	532998	2664.99	531996	2659.98	537000	2685	529998	2649.99	528996	2644.98	528000	2640

NR Band 77																								
Bandwidth 10MHz		Bandwidth 15MHz		Bandwidth 20MHz		Bandwidth 25MHz		Bandwidth 30MHz		Bandwidth 40MHz		Bandwidth 50MHz		Bandwidth 60MHz		Bandwidth 70MHz		Bandwidth 80MHz		Bandwidth 90MHz		Bandwidth 100MHz		
Ch. #	Freq. (MHz)	Ch. #	Freq. (MHz)	Ch. #	Freq. (MHz)	Ch. #	Freq. (MHz)	Ch. #	Freq. (MHz)	Ch. #	Freq. (MHz)	Ch. #	Freq. (MHz)	Ch. #	Freq. (MHz)	Ch. #	Freq. (MHz)	Ch. #	Freq. (MHz)	Ch. #	Freq. (MHz)	Ch. #	Freq. (MHz)	
L	647000	3705	647168	3707.52	647334	3710.01	647500	3712.5	647668	3715.02	648000	3720	648334	3725.01	648668	3730.02	649000	3735	649334	3740.01	649668	3745.02	650000	3750
M	656000	3840	656000	3840	656000	3840	656000	3840.00	656000	3840.00	656000	3840	656000	3840	656000	3840	656000	3840	656000	3840	656000	3840	656000	3840
H	665000	3975	664832	3972.48	664666	3969.99	664500	3967.50	664332	3964.98	664000	3960	663666	3954.99	663332	3949.98	663000	3945	662666	3939.99	662332	3934.98	662000	3930

NR Band 78																								
Bandwidth 10MHz		Bandwidth 15MHz		Bandwidth 20MHz		Bandwidth 25MHz		Bandwidth 30MHz		Bandwidth 40MHz		Bandwidth 50MHz		Bandwidth 60MHz		Bandwidth 70MHz		Bandwidth 80MHz		Bandwidth 90MHz		Bandwidth 100MHz		
Ch. #	Freq. (MHz)	Ch. #	Freq. (MHz)	Ch. #	Freq. (MHz)	Ch. #	Freq. (MHz)	Ch. #	Freq. (MHz)	Ch. #	Freq. (MHz)	Ch. #	Freq. (MHz)	Ch. #	Freq. (MHz)	Ch. #	Freq. (MHz)	Ch. #	Freq. (MHz)	Ch. #	Freq. (MHz)	Ch. #	Freq. (MHz)	
L	647000	3705	647168	3707.52	647334	3710.01	647500	3712.5	647668	3715.02	648000	3720	648334	3725.01	648668	3730.02	649000	3735	649334	3740.01	649668	3745.02		
M	650000	3750	650000	3750	650000	3750	650000	3750	650000	3750	650000	3750	650000	3750	650000	3750	650000	3750	650000	3750	650000	3750	650000	3750
H	653000	3795	652834	3792.51	652668	3790.02	652500	3787.5	652334	3785.01	652000	3780	651668	3775.02	651334	3770.01	651000	3765	650668	3760.02	650334	3755.01		

<For NR Overlap Bands Description>

1) NR Bands BW

Band	5 MHz	10 MHz	15 MHz	20 MHz	25 MHz	30 MHz	40 MHz	50 MHz	60 MHz	70 MHz	80 MHz	90 MHz	100 MHz
FR1 n5	Yes	Yes	Yes	Yes									
FR1 n26	Yes	Yes	Yes	Yes									
FR1 n38		Yes	Yes	Yes	Yes	Yes	Yes						
FR1 n41		Yes	Yes	Yes	Yes	Yes	Yes	Yes	Yes	Yes	Yes	Yes	Yes
FR1 n77		Yes	Yes	Yes	Yes	Yes	Yes	Yes	Yes	Yes	Yes	Yes	Yes
FR1 n78		Yes	Yes	Yes	Yes	Yes	Yes	Yes	Yes	Yes	Yes	Yes	Yes

2) NR Bands Tune up:

Band	Antenna	Head	Body-worn	Hotspot	Extremity	Sensor Off	Default
		DSI 2	DSI 3	DSI 7	DSI 6	DSI4	Tune-up Limit
		Tune-up Limit	Tune-up Limit	Tune-up Limit	Tune-up Limit	Tune-up Limit	
5G NR n5	Ant 0	24	24	24	24	24	24
5G NR n26	Ant 0	24	24	24	24	24	24



5G NR n5	Ant 1	24	24	24	24	24	24
5G NR n26	Ant 1	24	24	24	24	24	24
5G NR n38	Ant 2	24	21.4	19.7	20.6	24	24
5G NR n41	Ant 2	24	21.4	19.7	20.6	24	24
5G NR n38	Ant 1	18.3	21.3	17.6	21.7	24	24
5G NR n41	Ant 1	18.3	21.3	17.6	21.7	24	24
5G NR n38	Ant 0	24	23.7	20.9	21	24	24
5G NR n41	Ant 0	24	23.7	20.9	21	24	24
5G NR n38	Ant 3	18.4	22.5	18.8	22.4	24	24
5G NR n41	Ant 3	18.4	22.5	18.8	22.4	24	24
5G NR n77	Ant 4	20.8	20.6	17.6	21.4	24	24
5G NR n78	Ant 4	20.8	20.6	17.6	21.4	24	24
5G NR n77 HPUE	Ant 4	23.8	23.6	20.6	24.4	26.5	26.5
5G NR n78 HPUE	Ant 4	23.8	23.6	20.6	24.4	26.5	26.5
5G NR n77	Ant 5	19.7	20.2	19.4	22.9	24	24
5G NR n78	Ant 5	19.7	20.2	19.4	22.9	24	24
5G NR n77 HPUE	Ant 5	22.7	23.2	22.4	25.9	26	26
5G NR n78 HPUE	Ant 5	22.7	23.2	22.4	25.9	26	26
5G NR n77	Ant 7	18.4	20	17.1	21.3	24	24
5G NR n78	Ant 7	18.4	20	17.1	21.3	24	24
5G NR n77 HPUE	Ant 7	21.4	23	20.1	24.3	27	27
5G NR n78 HPUE	Ant 7	21.4	23	20.1	24.3	27	27
5G NR n77	Ant 8	24	24	22.6	24	24	24
5G NR n78	Ant 8	24	24	22.6	24	24	24
5G NR n77 HPUE	Ant 8	27	27	25.6	27	27	27
5G NR n78 HPUE	Ant 8	27	27	25.6	27	27	27

5. Smart Transmit feature for RF Exposure compliance

The 2nd generation of Smart Transmit (GEN2) operates based on pre-defined sub6 antenna groups (AG). This Device is enabled with the Qualcomm® Smart Transmit Gen2 feature. The RF exposure limit is defined based on time-averaged RF exposure. The product implements Qualcomm Smart Transmit feature which controls the instantaneous transmitting power for WWAN and WLAN/BT transmitter to ensure the product in compliance with RF exposure limit over a defined time window. To control and manage transmitting power in real time and to ensure at all times the time-averaged RF exposure is compliant to the regulation requirement.

This report describes the procedures for the SAR char generation, and the parameters obtained from SAR characterization (referred to as SAR char, respectively) will be used as input for Smart Transmit. SAR char will be entered via the Embedded File System (EFS) version 21 to enable the Smart Transmit Gen2 Feature.

<Terminologies in this report>

P_{limit}	The time-averaged RF power which corresponds to SAR_design_target.
P_{max}	Maximum target power level
SAR_design_target:	The design target for SAR compliance. It should be less than regulatory SAR limit to account for all device design related uncertainty.
SAR char	P _{limit} for all the technologies/bands for all applicable DSI

<SAR Characterization>

SAR char must be generated to cover all radio configurations and usage scenarios that the wireless device supports for operating at WWAN and WLAN/BT bands. It will then be used as input for Smart Transmit to control and manage RF exposure for WWAN and WLAN/BT bands.

<SAR design target and uncertainty>

Item	Uncertainty dB (k=2)
Total uncertainty	1.5

To account for total uncertainty, SAR_design_target should be determined as:

$$SAR_{design_target} < SAR_{regulatory_limit} \times 10^{\frac{-total\ uncertainty}{10}}$$

Antenna Group:

Antenna Group 0 (AG0)	ANT1 & ANT3& ANT4 & ANT5 & ANT6 & ANT7
Antenna Group 1 (AG1)	ANT0 & ANT2 & ANT8



The Smart Transmit algorithm maintains the time-averaged transmit power, in turn, time-averaged RF exposure of SAR_design_target, below the predefined time-averaged power limit, for each characterized technology and band.

Smart Transmit allows the device to transmit at higher power instantaneously, as high as Pmax, when needed, but enforces power limiting to maintain time-averaged transmit power to Plimit. Below table shows Plimit EFS settings and maximum tune up output power Pmax configured for this EUT for various transmit conditions (Device State Index DSI).

<P_{limit} for supported technologies and bands (P_{limit} in EFS file)>

Band	Antenna	Head DSI 2	Body-Worn DSI 3	Hotspot DSI 7	Extremity DSI 6	Sensor off DSI 4	Pmax*
GSM850	Ant 0	33.5	26.4	26.4	24.7	24.7	24.7
GSM850	Ant 1	23.2	25.1	25.1	24.7	24.7	24.7
GSM1900	Ant 2	34.4	21.9	21.9	22.3	21.7	21.7
GSM1900	Ant 1	19.9	18.8	18.8	20	19.7	19.7
WCDMA II	Ant 2	31	20.1	20.1	21.2	23.0	23.0
WCDMA II	Ant 1	17	17.2	17.2	18.8	20.5	20.5
WCDMA IV	Ant 2	31.4	19.2	17.9	21.5	23.0	23.0
WCDMA IV	Ant 1	17.5	17.9	17.9	19.2	20.5	20.5
WCDMA V	Ant 0	31.2	23.5	23.5	23.0	23.0	23.0
WCDMA V	Ant 1	23.1	22.5	22.5	26.0	23.0	23.0
LTE Band 7	Ant 2	29.3	19.6	17.9	19.3	23.0	23.0
LTE Band 7	Ant 1	17.4	19.8	15.7	20.2	23.0	23.0
LTE Band 7 Other PA	Ant 1	17.4	19.8	15.7	20.2	23.0	23.0
LTE Band 7	Ant 0	31.3	21.7	21.7	21.9	23.0	23.0
LTE Band 7	Ant 3	18.2	21.8	20.4	22	22.0	22.0
LTE Band 12(17)	Ant 0	32	24.7	24.5	23.0	23.0	23.0
LTE Band 12(17)	Ant 1	22.4	24.1	24.1	23.0	23.0	23.0
LTE Band 13	Ant 0	32.2	24.6	24.4	23.0	23.0	23.0
LTE Band 13 ENDC	Ant 1	24.1	24.7	24.7	23.0	23.0	23.0
LTE Band 25(2)	Ant 2	29.9	20.1	18.5	21.2	23.0	23.0
LTE Band 25(2)	Ant 1	16.4	16.5	16.5	18.5	23.0	23.0
LTE Band 2 Other PA	Ant 1	16.4	16.5	16.5	18.5	23.0	23.0
LTE Band 26(5)	Ant 0	29.7	23.2	23.2	23.0	23.0	23.0
LTE Band 26(5)	Ant 1	22.5	22.4	22.4	25.3	23.0	23.0
LTE Band 66(4)	Ant 2	29.6	19	17.9	21	23.0	23.0
LTE Band 66(4)	Ant 1	17.2	17.6	17.6	19.4	23.0	23.0
LTE Band 66(4) Other PA	Ant 1	17.2	17.6	17.6	19.4	23.0	23.0
LTE Band 41(38)	Ant 2	28.7	19.3	18.7	19.8	22.4	21.0
LTE Band 41 HPUE	Ant 2	28.7	19.3	18.7	19.8	22.4	22.4
LTE Band 41(38)	Ant 1	17	19.6	16	20	22.4	21.0
LTE Band 41 HPUE	Ant 1	17	19.6	16	20	22.4	22.4
LTE Band 41(38) Other PA	Ant 1	17	19.6	16	20	22.4	21.0
LTE Band 41 HPUE Other PA	Ant 1	17	19.6	16	20	22.4	22.4
LTE Band 41(38)	Ant 0	33.6	20.8	18.5	21.6	22.4	21.0
LTE Band 41 HPUE	Ant 0	33.6	20.8	18.5	21.6	22.4	22.4
LTE Band 41(38)	Ant 3	16.9	21.9	16.5	20.9	21.4	20.0
LTE Band 41 HPUE	Ant 3	16.9	21.9	16.5	20.9	21.4	21.4
LTE Band 42	Ant 7	18	21.3	17.7	21.1	21.0	21.0
FR1 n26(5)	Ant 0	32.5	25.2	25.2	23.0	23.0	23.0
FR1 n26(5)	Ant 1	23.7	24.5	24.5	23.0	23.0	23.0
FR1 n2	Ant 2	32.3	20	19.3	23.3	23.0	23.0
FR1 n2	Ant 1	17.5	18.1	18.1	20.3	23.0	23.0
FR1 n7	Ant 2	30.7	20	17.9	20.6	23.0	23.0
FR1 n7	Ant 1	17.6	20.6	17.1	20.8	23.0	23.0
FR1 n66	Ant 2	31.3	19.9	18.4	22.6	23.0	23.0



FR1 n66	Ant 1	19.1	21	21	21.7	23.0	23.0
FR1 n71	Ant 0	34	26.7	26.7	23.0	23.0	23.0
FR1 n71	Ant 1	25.8	28.5	28.5	23.0	23.0	23.0
FR1 n41(38)	Ant 2	31.2	20.4	18.7	19.6	23.0	23.0
FR1 n41(38)	Ant 1	17.3	20.3	16.6	20.7	23.0	23.0
FR1 n41(38)	Ant 0	28.2	22.7	19.9	20	23.0	23.0
FR1 n41(38)	Ant 3	17.4	21.5	17.8	21.4	23.0	23.0
FR1 n77 Part 270	Ant 4	19.8	19.6	16.6	20.4	23.0	23.0
FR1 n77 Part 270 HPUE	Ant 4	19.8	19.6	16.6	20.4	23.0	22.5
FR1 n77 Part 270	Ant 5	18.7	19.2	18.4	21.9	23.0	23.0
FR1 n77 Part 270 HPUE	Ant 5	18.7	19.2	18.4	21.9	23.0	22.0
FR1 n77 Part 270	Ant 7	17.4	19.0	16.1	20.3	23.0	23.0
FR1 n77 Part 270 HPUE	Ant 7	17.4	19.0	16.1	20.3	23.0	23.0
FR1 n77 Part 270	Ant 8	28.6	24.2	21.6	23.0	23.0	23.0
FR1 n77 Part 270 HPUE	Ant 8	28.6	24.2	21.6	23.0	23.0	23.0

Band	Antenna	Head DSI 2	Body-Worn DSI 3	Extremity DSI 6	Hotspot DSI 7	Sensor off DSI 4	Pmax*
WLAN2.4GHz	Ant 6	17.50	17.00	20.50	17.00	21.90	21.90
WLAN2.4GHz	Ant 3	17.50	17.00	20.50	17.00	21.90	21.90
WLAN2.4GHz	Ant 6+3	17.50	17.00	20.50	17.00	24.90	24.90
Bluetooth	ANT 6	22.50	18.10	14.90	18.10	14.90	14.90
Bluetooth	ANT 3	22.20	22.60	16.40	22.60	16.40	16.40
WLAN5GHz(B1)	Ant 5	15.50	15.50	20.70	15.50	18.50	18.50
WLAN5GHz(B1)	Ant 4	15.50	15.50	20.70	15.50	18.50	18.50
WLAN5GHz(B1)	Ant 5+4	15.50	15.50	20.70	15.50	21.50	21.50
WLAN5GHz(B2)	Ant 5	15.50	15.50	21.40		18.50	18.50
WLAN5GHz(B2)	Ant 4	15.50	15.50	21.40		18.50	18.50
WLAN5GHz(B2)	Ant 5+4	15.50	15.50	21.40		21.50	21.50
WLAN5GHz(B3)	Ant 5	17.00	15.00	19.00		19.00	19.00
WLAN5GHz(B3)	Ant 4	17.00	15.00	19.00		19.00	19.00
WLAN5GHz(B3)	Ant 5+4	17.00	15.00	19.00		22.00	22.00
WLAN5GHz(B4)	Ant 5	17.00	18.50	18.50	18.50	18.50	18.50
WLAN5GHz(B4)	Ant 4	17.00	18.50	18.50	18.50	18.50	18.50
WLAN5GHz(B4)	Ant 5+4	17.00	18.50	18.50	18.50	21.50	21.50
WLAN6GHz(B5)	Ant 5	16.00	16.50	16.00		16.50	16.50
WLAN6GHz(B5)	Ant 4	16.00	16.50	16.00		16.50	16.50
WLAN6GHz(B5)	Ant 5+4	16.00	16.50	16.00		19.50	19.50
WLAN6GHz(B6)	Ant 5	16.00	17.00	16.00		17.00	17.00
WLAN6GHz(B6)	Ant 4	16.00	17.00	16.00		17.00	17.00
WLAN6GHz(B6)	Ant 5+4	16.00	17.00	16.00		20.00	20.00
WLAN6GHz(B7)	Ant 5	15.00	17.00	15.00		17.00	17.00
WLAN6GHz(B7)	Ant 4	15.00	17.00	15.00		17.00	17.00
WLAN6GHz(B7)	Ant 5+4	15.00	17.00	15.00		20.00	20.00
WLAN6GHz(B8)	Ant 5	14.50	15.00	14.50		15.00	15.00
WLAN6GHz(B8)	Ant 4	14.50	15.00	14.50		15.00	15.00
WLAN6GHz(B8)	Ant 5+4	14.50	15.00	14.50		18.00	18.00

Note:

- *Pmax is used for RF tune up procedure. The maximum allowed output power is equal to Pmax + total uncertainty (The device uncertainty for sub-6GHz WWAN is 1.0 dB for this DUT, the device uncertainty for WLAN/BT Bands is 1.5 dB).
- All Plimit power levels entered in the Table correspond to average power levels after accounting for duty cycle in the case TDD modulation schemes (for e.g., GSM & LTE TDD & NR TDD).
- The max allowed output power is the Plimit + 1.0 dB device uncertainty, and if Plimit is higher than Pmax, the device output power will be Pmax instead.
- For 5G NR n77/n78 HPUE, 5G NR n77/n78 PC2 Maximum Duty Cycle is 50%, using FTM (Factory Test Mode) with 50% duty cycle is considered during SAR testing. For 5G NR other bands, using FTM to perform SAR with default 100% transmission.

6. Proximity Sensor Triggering Test

<Proximity Sensor Triggering Distance>:

1. Proximity sensor triggering distance testing was performed according to the procedures outlined in KDB 616217 D04 section 6.2, and EUT moving further away from the flat phantom and EUT moving toward the flat phantom were both assessed and the tissue-equivalent medium for highest frequency (7125MHz) and lowest (835MHz) frequency was used for proximity sensor triggering testing.
2. Capacitive proximity sensors placed coincident with antenna elements at the top and bottom ends of the phone are utilized to determine when the device comes in proximity of the user's body at the front or back of the device.
3. The output power will reduce to body worn power level when top and bottom sensor pad be detected.
4. The sensors used to detect the proximity of the user's body at the front or back surface of the device use a detection threshold distance. The data shown in the sections below shows the distance(s). When front or back body worn condition is detected reduced power will be active.
5. The device employs proximity sensors also can detect the presence of the user's a finger or hand when handheld state at the front/back/top/bottom/left/right sides of the device. When front/back/top/bottom/left/right sides of handheld condition is detected reduced power will be active.
6. For verification of compliance of power reduction scheme, additional SAR testing with EUT transmitting at full RF power at a conservative trigger distance -1mm was performed:

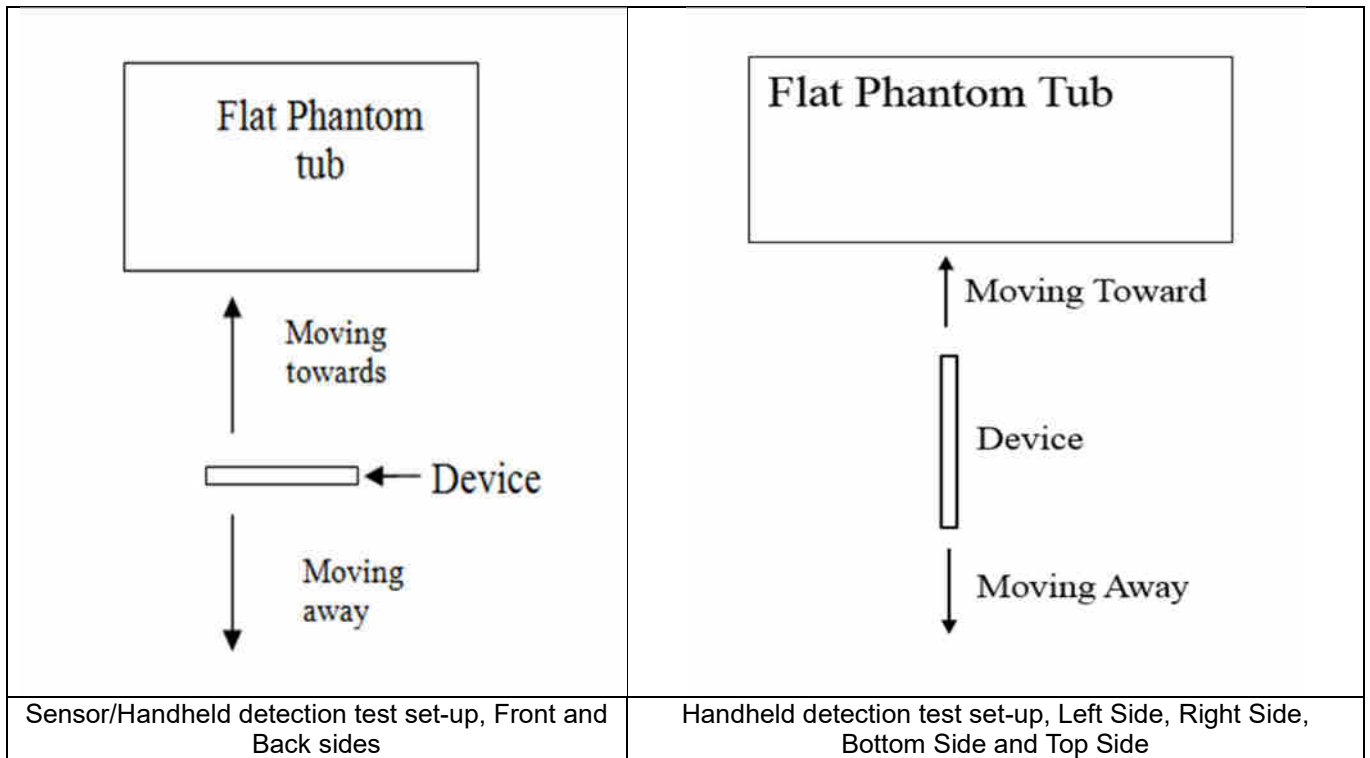

<P-Sensor>

Proximity Sensor Triggering Distance (mm)				
Position	Front		Back	
	Moving towards	Moving away	Moving towards	Moving away
Minimum	18	23	19	24

<Handheld for ANT 0&2>

Proximity Sensor Triggering Distance (mm)								
Position	Front		Back		Left Side		Bottom Side	
	Moving towards	Moving away	Moving towards	Moving away	Moving towards	Moving away	Moving towards	Moving away
Minimum	12	17	10	16	10	16	13	19

<Handheld for ANT1&7>

Proximity Sensor Triggering Distance (mm)								
Position	Front		Back		Left Side		Top Side	
	Moving towards	Moving away	Moving towards	Moving away	Moving towards	Moving away	Moving towards	Moving away
Minimum	7	13	12	18	12	18	9	15

<Handheld for ANT3&4&5&6>

Proximity Sensor Triggering Distance (mm)								
Position	Front		Back		Right Side		Top Side	
	Moving towards	Moving away	Moving towards	Moving away	Moving towards	Moving away	Moving towards	Moving away
Minimum	8	14	11	16	12	18	9	15

7. RF Exposure Limits

7.1 Uncontrolled Environment

Uncontrolled Environments are defined as locations where there is the exposure of individuals who have no knowledge or control of their exposure. The general population/uncontrolled exposure limits are applicable to situations in which the general public may be exposed or in which persons who are exposed as a consequence of their employment may not be made fully aware of the potential for exposure or cannot exercise control over their exposure. Members of the general public would come under this category when exposure is not employment-related; for example, in the case of a wireless transmitter that exposes persons in its vicinity.

7.2 Controlled Environment

Controlled Environments are defined as locations where there is exposure that may be incurred by persons who are aware of the potential for exposure, (i.e. as a result of employment or occupation). In general, occupational/controlled exposure limits are applicable to situations in which persons are exposed as a consequence of their employment, who have been made fully aware of the potential for exposure and can exercise control over their exposure. The exposure category is also applicable when the exposure is of a transient nature due to incidental passage through a location where the exposure levels may be higher than the general population/uncontrolled limits, but the exposed person is fully aware of the potential for exposure and can exercise control over his or her exposure by leaving the area or by some other appropriate means.

Limits for Occupational/Controlled Exposure (W/kg)

Whole-Body	Partial-Body	Hands, Wrists, Feet and Ankles
0.4	8.0	20.0

Limits for General Population/Uncontrolled Exposure (W/kg)

Whole-Body	Partial-Body	Hands, Wrists, Feet and Ankles
0.08	1.6	4.0

Whole-Body SAR is averaged over the entire body, partial-body SAR is averaged over any 1gram of tissue defined as a tissue volume in the shape of a cube. SAR for hands, wrists, feet and ankles is averaged over any 10 grams of tissue defined as a tissue volume in the shape of a cube.

8. Specific Absorption Rate (SAR)

8.1 Introduction

SAR is related to the rate at which energy is absorbed per unit mass in an object exposed to a radio field. The SAR distribution in a biological body is complicated and is usually carried out by experimental techniques or numerical modeling. The standard recommends limits for two tiers of groups, occupational/controlled and general population/uncontrolled, based on a person's awareness and ability to exercise control over his or her exposure. In general, occupational/controlled exposure limits are higher than the limits for general population/uncontrolled.

8.2 SAR Definition

The SAR definition is the time derivative (rate) of the incremental energy (dW) absorbed by (dissipated in) an incremental mass (dm) contained in a volume element (dv) of a given density (ρ). The equation description is as below:

$$\text{SAR} = \frac{d}{dt} \left(\frac{dW}{dm} \right) = \frac{d}{dt} \left(\frac{dW}{\rho dv} \right)$$

SAR is expressed in units of Watts per kilogram (W/kg)

$$\text{SAR} = \frac{\sigma |E|^2}{\rho}$$

Where: σ is the conductivity of the tissue, ρ is the mass density of the tissue and E is the RMS electrical field strength.

9. System Description and Setup

The DASY5 system used for performing compliance tests consists of the following items:

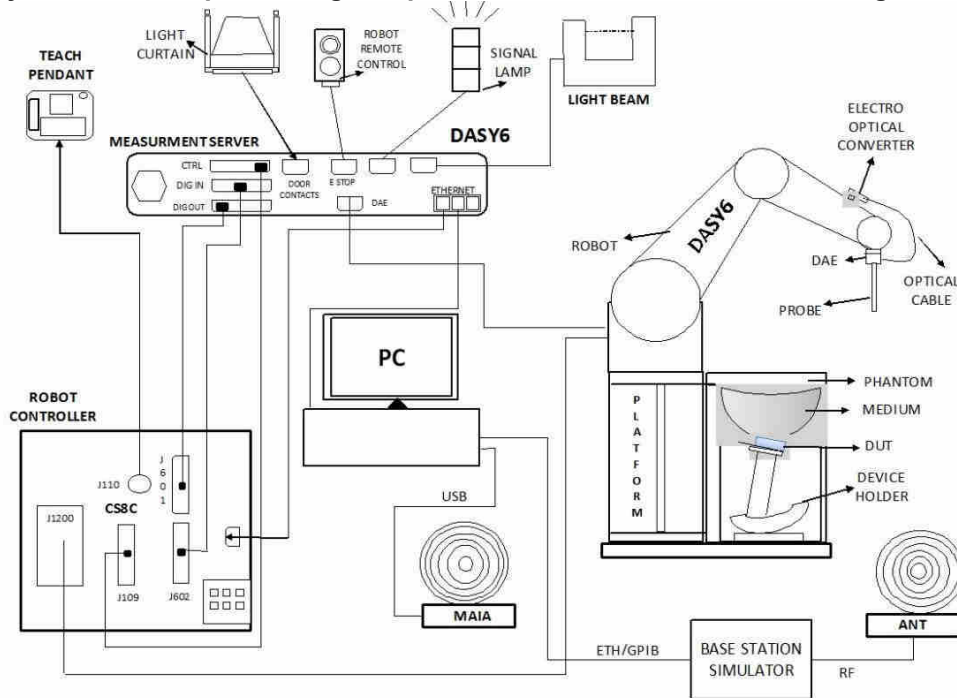

- A standard high precision 6-axis robot with controller, teach pendant and software. An arm extension for accommodating the data acquisition electronics (DAE).
- An isotropic Field probe optimized and calibrated for the targeted measurement.
- A data acquisition electronics (DAE) which performs the signal amplification, signal multiplexing, AD-conversion, offset measurements, mechanical surface detection, collision detection, etc. The unit is battery powered with standard or rechargeable batteries. The signal is optically transmitted to the EOC.
- The Electro-optical converter (EOC) performs the conversion from optical to electrical signals for the digital communication to the DAE. To use optical surface detection, a special version of the EOC is required. The EOC signal is transmitted to the measurement server.
- The function of the measurement server is to perform the time critical tasks such as signal filtering, control of the robot operation and fast movement interrupts.
- The Light Beam used is for probe alignment. This improves the (absolute) accuracy of the probe positioning.
- A computer running Win7 or Win10 and the DASY5 or DASY6 software.
- Remote control and teach pendant as well as additional circuitry for robot safety such as warning lamps, etc.
- The phantom, the device holder and other accessories according to the targeted measurement.

9.1 E-Field Probe

The SAR measurement is conducted with the dosimetric probe (manufactured by SPEAG).The probe is specially designed and calibrated for use in liquid with high permittivity. The dosimetric probe has special calibration in liquid at different frequency. This probe has a built in optical surface detection system to prevent from collision with phantom.

<EX3DV4 Probe>

Construction	Symmetric design with triangular core Built-in shielding against static charges PEEK enclosure material (resistant to organic solvents, e.g., DGBE)	
Frequency	10 MHz – >6 GHz Linearity: ±0.2 dB (30 MHz – 6 GHz)	
Directivity	±0.3 dB in TSL (rotation around probe axis) ±0.5 dB in TSL (rotation normal to probe axis)	
Dynamic Range	10 µW/g – >100 mW/g Linearity: ±0.2 dB (noise: typically <1 µW/g)	
Dimensions	Overall length: 337 mm (tip: 20 mm) Tip diameter: 2.5 mm (body: 12 mm) Typical distance from probe tip to dipole centers: 1 mm	

9.2 Data Acquisition Electronics (DAE)

The data acquisition electronics (DAE) consists of a highly sensitive electrometer-grade preamplifier with auto-zeroing, a channel and gain-switching multiplexer, a fast 16 bit AD-converter and a command decoder and control logic unit. Transmission to the measurement server is accomplished through an optical downlink for data and status information as well as an optical uplink for commands and the clock.

The input impedance of the DAE is 200 MOhm; the inputs are symmetrical and floating. Common mode rejection is above 80 dB.



Photo of DAE

9.3 Phantom

<SAM Twin Phantom>

Shell Thickness	2 ± 0.2 mm; Center ear point: 6 ± 0.2 mm	
Filling Volume	Approx. 25 liters	
Dimensions	Length: 1000 mm; Width: 500 mm; Height: adjustable feet	
Measurement Areas	Left Hand, Right Hand, Flat Phantom	

The bottom plate contains three pair of bolts for locking the device holder. The device holder positions are adjusted to the standard measurement positions in the three sections. A white cover is provided to tap the phantom during off-periods to prevent water evaporation and changes in the liquid parameters. On the phantom top, three reference markers are provided to identify the phantom position with respect to the robot.

<ELI Phantom>

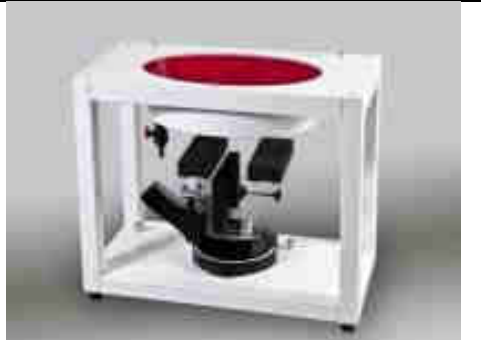
Shell Thickness	2 ± 0.2 mm (sagging: <1%)	
Filling Volume	Approx. 30 liters	
Dimensions	Major ellipse axis: 600 mm Minor axis: 400 mm	

The ELI phantom is intended for compliance testing of handheld and body-mounted wireless devices or for evaluating transmitters operating at low frequencies. ELI is fully compatible with standard and all known tissue simulating liquids.

9.4 Device Holder

<Mounting Device for Hand-Held Transmitter>

In combination with the Twin SAM V5.0/V5.0c or ELI phantoms, the Mounting Device for Hand-Held Transmitters enables rotation of the mounted transmitter device to specified spherical coordinates. At the heads, the rotation axis is at the ear opening. Transmitter devices can be easily and accurately positioned according to IEC 62209-1, IEEE 1528, FCC, or other specifications. The device holder can be locked for positioning at different phantom sections (left head, right head, flat). And upgrade kit to Mounting Device to enable easy mounting of wider devices like big smart-phones, e-books, small tablets, etc. It holds devices with width up to 140 mm.



Mounting Device for Hand-Held Transmitters



Mounting Device Adaptor for Wide-Phones

<Mounting Device for Laptops and other Body-Worn Transmitters>

The extension is lightweight and made of POM, acrylic glass and foam. It fits easily on the upper part of the mounting device in place of the phone positioned. The extension is fully compatible with the SAM Twin and ELI phantoms.



Mounting Device for Laptops

10. Measurement Procedures

The measurement procedures are as follows:

<Conducted power measurement>

- (a) For WWAN power measurement, use base station simulator to configure EUT WWAN transmission in conducted connection with RF cable, at maximum power in each supported wireless interface and frequency band.
- (b) Read the WWAN RF power level from the base station simulator.
- (c) For WLAN/BT power measurement, use engineering software to configure EUT WLAN/BT continuously transmission, at maximum RF power in each supported wireless interface and frequency band
- (d) Connect EUT RF port through RF cable to the power meter, and measure WLAN/BT output power

<SAR measurement>

- (a) Use base station simulator to configure EUT WWAN transmission in radiated connection, and engineering software to configure EUT WLAN/BT continuously transmission, at maximum RF power, in the highest power channel.
- (b) Place the EUT in the positions as Appendix D demonstrates.
- (c) Set scan area, grid size and other setting on the DASY software.
- (d) Measure SAR results for the highest power channel on each testing position.
- (e) Find out the largest SAR result on these testing positions of each band
- (f) Measure SAR results for other channels in worst SAR testing position if the reported SAR of highest power channel is larger than 0.8 W/kg

According to the test standard, the recommended procedure for assessing the peak spatial-average SAR value consists of the following steps:

- (a) Power reference measurement
- (b) Area scan
- (c) Zoom scan
- (d) Power drift measurement

10.1 Spatial Peak SAR Evaluation

The procedure for spatial peak SAR evaluation has been implemented according to the test standard. It can be conducted for 1g and 10g, as well as for user-specific masses. The DASY software includes all numerical procedures necessary to evaluate the spatial peak SAR value.

The base for the evaluation is a "cube" measurement. The measured volume must include the 1g and 10g cubes with the highest averaged SAR values. For that purpose, the center of the measured volume is aligned to the interpolated peak SAR value of a previously performed area scan.

The entire evaluation of the spatial peak values is performed within the post-processing engine (SEMCAD). The system always gives the maximum values for the 1g and 10g cubes. The algorithm to find the cube with highest averaged SAR is divided into the following stages:

- (a) Extraction of the measured data (grid and values) from the Zoom Scan
- (b) Calculation of the SAR value at every measurement point based on all stored data (A/D values and measurement parameters)
- (c) Generation of a high-resolution mesh within the measured volume
- (d) Interpolation of all measured values from the measurement grid to the high-resolution grid
- (e) Extrapolation of the entire 3-D field distribution to the phantom surface over the distance from sensor to surface
- (f) Calculation of the averaged SAR within masses of 1g and 10g

10.2 Power Reference Measurement

The Power Reference Measurement and Power Drift Measurements are for monitoring the power drift of the device under test in the batch process. The minimum distance of probe sensors to surface determines the closest measurement point to phantom surface. This distance cannot be smaller than the distance of sensor calibration points to probe tip as defined in the probe properties.

10.3 Area Scan

The area scan is used as a fast scan in two dimensions to find the area of high field values, before doing a fine measurement around the hot spot. The sophisticated interpolation routines implemented in DASY software can find the maximum found in the scanned area, within a range of the global maximum. The range (in dB0 is specified in the standards for compliance testing. For example, a 2 dB range is required in IEEE standard 1528 and IEC 62209 standards, whereby 3 dB is a requirement when compliance is assessed in accordance with the ARIB standard (Japan), if only one zoom scan follows the area scan, then only the absolute maximum will be taken as reference. For cases where multiple maximums are detected, the number of zoom scans has to be increased accordingly.

Area scan parameters extracted from FCC KDB 865664 D01v01r04 SAR measurement 100 MHz to 6 GHz.

	≤ 3 GHz	> 3 GHz
Maximum distance from closest measurement point (geometric center of probe sensors) to phantom surface	5 ± 1 mm	$\frac{1}{2} \cdot \delta \cdot \ln(2) \pm 0.5$ mm
Maximum probe angle from probe axis to phantom surface normal at the measurement location	$30^\circ \pm 1^\circ$	$20^\circ \pm 1^\circ$
Maximum area scan spatial resolution: Δx_{Area} , Δy_{Area}	≤ 2 GHz: ≤ 15 mm $2 - 3$ GHz: ≤ 12 mm	$3 - 4$ GHz: ≤ 12 mm $4 - 6$ GHz: ≤ 10 mm
	When the x or y dimension of the test device, in the measurement plane orientation, is smaller than the above, the measurement resolution must be \leq the corresponding x or y dimension of the test device with at least one measurement point on the test device.	

10.4 Zoom Scan

Zoom scans are used to assess the peak spatial SAR values within a cubic averaging volume containing 1 gram and 10 gram of simulated tissue. The zoom scan measures points (refer to table below) within a cube whose base faces are centered on the maxima found in a preceding area scan job within the same procedure. When the measurement is done, the zoom scan evaluates the averaged SAR for 1 gram and 10 gram and displays these values next to the job's label.

Zoom scan parameters extracted from FCC KDB 865664 D01v01r04 SAR measurement 100 MHz to 6 GHz.

		≤ 3 GHz	> 3 GHz	
Maximum zoom scan spatial resolution: Δx_{Zoom} , Δy_{Zoom}		≤ 2 GHz: ≤ 8 mm 2 – 3 GHz: ≤ 5 mm*	3 – 4 GHz: ≤ 5 mm* 4 – 6 GHz: ≤ 4 mm*	
Maximum zoom scan spatial resolution, normal to phantom surface	uniform grid: $\Delta z_{Zoom}(n)$	≤ 5 mm	3 – 4 GHz: ≤ 4 mm 4 – 5 GHz: ≤ 3 mm 5 – 6 GHz: ≤ 2 mm	
	graded grid	$\Delta z_{Zoom}(1)$: between 1 st two points closest to phantom surface	≤ 4 mm	3 – 4 GHz: ≤ 3 mm 4 – 5 GHz: ≤ 2.5 mm 5 – 6 GHz: ≤ 2 mm
		$\Delta z_{Zoom}(n>1)$: between subsequent points	$\leq 1.5 \cdot \Delta z_{Zoom}(n-1)$	
Minimum zoom scan volume	x, y, z	≥ 30 mm	3 – 4 GHz: ≥ 28 mm 4 – 5 GHz: ≥ 25 mm 5 – 6 GHz: ≥ 22 mm	
Note: δ is the penetration depth of a plane-wave at normal incidence to the tissue medium; see draft standard IEEE P1528-2011 for details. * When zoom scan is required and the <i>reported</i> SAR from the <i>area scan based 1-g SAR estimation</i> procedures of KDB 447498 is ≤ 1.4 W/kg, ≤ 8 mm, ≤ 7 mm and ≤ 5 mm zoom scan resolution may be applied, respectively, for 2 GHz to 3 GHz, 3 GHz to 4 GHz and 4 GHz to 6 GHz.				

10.5 Volume Scan Procedures

The volume scan is used to assess overlapping SAR distributions for antennas transmitting in different frequency bands. It is equivalent to an oversized zoom scan used in standalone measurements. The measurement volume will be used to enclose all the simultaneous transmitting antennas. For antennas transmitting simultaneously in different frequency bands, the volume scan is measured separately in each frequency band. In order to sum correctly to compute the 1g aggregate SAR, the EUT remain in the same test position for all measurements and all volume scan use the same spatial resolution and grid spacing. When all volume scan were completed, the software, SEMCAD postprocessor can combine and subsequently superpose these measurement data to calculating the multiband SAR.

10.6 Power Drift Monitoring

All SAR testing is under the EUT install full charged battery and transmit maximum output power. In DASy measurement software, the power reference measurement and power drift measurement procedures are used for monitoring the power drift of EUT during SAR test. Both these procedures measure the field at a specified reference position before and after the SAR testing. The software will calculate the field difference in dB. If the power drifts more than 5%, the SAR will be retested.



11. Test Equipment List

Manufacturer	Name of Equipment	Type/Model	Serial Number	Calibration	
				Last Cal.	Due Date
SPEAG	750MHz System Validation Kit	D750V3	1087	2022/2/24	2025/2/22
SPEAG	835MHz System Validation Kit	D835V2	4d091	2022/8/19	2025/8/18
SPEAG	1750MHz System Validation Kit	D1750V2	1090	2022/2/24	2025/2/22
SPEAG	1900MHz System Validation Kit	D1900V2	5d118	2022/3/30	2025/3/29
SPEAG	2450MHz System Validation Kit	D2450V2	1040	2023/4/25	2024/4/24
SPEAG	2600MHz System Validation Kit	D2600V2	1070	2021/12/20	2024/12/18
SPEAG	3500MHz System Validation Kit	D3500V2	1037	2023/11/20	2024/11/19
SPEAG	3700MHz System Validation Kit	D3700V2	1008	2023/11/20	2024/11/19
SPEAG	3900MHz System Validation Kit	D3900V2	1048	2023/3/9	2026/3/8
SPEAG	5000MHz System Validation Kit	D5GHZV2	1113	2022/9/23	2025/9/22
SPEAG	Data Acquisition Electronics	DAE4	1649	2023/4/24	2024/4/23
SPEAG	Data Acquisition Electronics	DAE4	690	2023/6/20	2024/6/19
SPEAG	Dosimetric E-Field Probe	EX3DV4	7627	2023/6/6	2024/6/5
SPEAG	Dosimetric E-Field Probe	EX3DV4	7764	2023/10/5	2024/10/4
SPEAG	SAM Twin Phantom	SAM Twin	TP-1644	NCR	NCR
SPEAG	SAM Twin Phantom	SAM Twin	TP-2022	NCR	NCR
Testo	Thermo-Hygrometer	608-H1	1241332126	2023/7/10	2024/7/9
SPEAG	Phone Positioner	N/A	N/A	NCR	NCR
Anritsu	Radio Communication Analyzer	MT8821C	6262306175	2023/7/5	2024/7/4
Agilent	ENA Series Network Analyzer	E5071C	MY46111157	2023/7/5	2024/7/4
SPEAG	Dielectric Probe Kit	DAK-3.5	1144	2023/8/17	2024/8/16
Anritsu	Vector Signal Generator	MG3710A	6201682672	2024/1/2	2025/1/1
Rohde & Schwarz	Power Meter	NRVD	102081	2023/7/5	2024/7/4
Rohde & Schwarz	Power Sensor	NRV-Z5	100538	2023/7/5	2024/7/4
Rohde & Schwarz	Power Sensor	NRV-Z5	100539	2023/7/5	2024/7/4
R&S	BLUETOOTH TESTER	CBT	101246	2023/5/15	2024/5/14
Rohde & Schwarz	Spectrum Analyzer	FSV7	101631	2023/10/11	2024/10/10
TES	DIGITAC THERMOMETER	1310	220305411	2023/7/8	2024/7/7
BONN	POWER AMPLIFIER	BLMA 0830-3	087193A	Note 1	
BONN	POWER AMPLIFIER	BLMA 2060-2	087193B	Note 1	
Agilent	Dual Directional Coupler	778D	20500	Note 1	
Agilent	Dual Directional Coupler	11691D	MY48151020	Note 1	
ARRA	Power Divider	A3200-2	N/A	Note 1	
MCL	Attenuation1	BW-S10W5+	N/A	Note 1	
MCL	Attenuation2	BW-S10W5+	N/A	Note 1	
MCL	Attenuation3	BW-S10W5+	N/A	Note 1	

Note:

1. Prior to system verification and validation, the path loss from the signal generator to the system check source and the power meter, which includes the amplifier, cable, attenuator and directional coupler, was measured by the network analyzer. The reading of the power meter was offset by the path loss difference between the path to the power meter and the path to the system check source to monitor the actual power level fed to the system check
2. Referring to KDB 865664 D01v01r04, the dipole calibration interval can be extended to 3 years with justification. The dipoles are also not physically damaged, or repaired during the interval.
3. The justification data of dipole can be found in appendix C. The return loss is < -20dB, within 20% of prior calibration, the impedance is within 5 ohm of prior calibration.

12. System Verification

12.1 Tissue Simulating Liquids

For the measurement of the field distribution inside the SAM phantom with DASY, the phantom must be filled with around 25 liters of homogeneous body tissue simulating liquid. For head SAR testing, the liquid height from the ear reference point (ERP) of the phantom to the liquid top surface is larger than 15 cm, which is shown in Fig. 11.1. For body SAR testing, the liquid height from the center of the flat phantom to the liquid top surface is larger than 15 cm, which is shown in Fig. 11.2.



Fig 11.1 Photo of Liquid Height for Head SAR



Fig 11.2 Photo of Liquid Height for Body SAR

12.2 Tissue Verification

The following tissue formulations are provided for reference only as some of the parameters have not been thoroughly verified. The composition of ingredients may be modified accordingly to achieve the desired target tissue parameters required for routine SAR evaluation.

Frequency (MHz)	Water (%)	Sugar (%)	Cellulose (%)	Salt (%)	Preventol (%)	DGBE (%)	Conductivity (σ)	Permittivity (ϵ_r)
For Head								
750	41.1	57.0	0.2	1.4	0.2	0	0.89	41.9
835	40.3	57.9	0.2	1.4	0.2	0	0.90	41.5
1800, 1900, 2000	55.2	0	0	0.3	0	44.5	1.40	40.0
2450	55.0	0	0	0	0	45.0	1.80	39.2
2600	54.8	0	0	0.1	0	45.1	1.96	39.0

Simulating Liquid for 5GHz, Manufactured by SPEAG

Ingredients	(% by weight)
Water	64~78%
Mineral oil	11~18%
Emulsifiers	9~15%
Additives and Salt	2~3%



<Tissue Dielectric Parameter Check Results>

Frequency (MHz)	Tissue Type	Liquid Temp. (°C)	Conductivity (σ)	Permittivity (ε _r)	Conductivity Target (σ)	Permittivity Target (ε _r)	Delta (σ) (%)	Delta (ε _r) (%)	Limit (%)	Date
750	Head	22.6	0.900	41.200	0.89	41.90	1.12	-1.67	±5	2024/2/26
835	Head	22.8	0.902	41.200	0.90	41.50	0.22	-0.72	±5	2024/2/27
1750	Head	22.7	1.400	40.700	1.37	40.10	2.19	1.50	±5	2024/2/28
1900	Head	22.9	1.400	39.000	1.40	40.00	0.00	-2.50	±5	2024/2/29
2600	Head	22.7	1.930	38.200	1.96	39.00	-1.53	-2.05	±5	2024/3/1
3500	Head	22.7	2.780	38.900	2.91	37.90	-4.47	2.64	±5	2024/3/2
3700	Head	22.8	2.990	38.700	3.12	37.70	-4.17	2.65	±5	2024/3/4
3900	Head	22.8	3.190	38.400	3.32	37.50	-3.92	2.40	±5	2024/3/5
750	Head	22.8	0.926	42.500	0.89	41.90	4.04	1.43	±5	2024/3/6
835	Head	22.7	0.938	42.100	0.90	41.50	4.22	1.45	±5	2024/3/7
1750	Head	22.9	1.380	40.300	1.37	40.10	0.73	0.50	±5	2024/3/8
1900	Head	22.7	1.450	40.000	1.40	40.00	3.57	0.00	±5	2024/3/9
2600	Head	22.6	1.940	39.100	1.96	39.00	-1.02	0.26	±5	2024/3/10
3500	Head	22.9	2.790	39.600	2.91	37.90	-4.12	4.49	±5	2024/3/11
3700	Head	22.7	2.990	38.400	3.12	37.70	-4.17	1.86	±5	2024/3/12
3900	Head	22.8	3.190	38.400	3.32	37.50	-3.92	2.40	±5	2024/3/13
2450	Head	22.7	1.860	38.400	1.80	39.20	3.33	-2.04	±5	2024/3/14
5250	Head	22.6	4.600	35.900	4.71	35.90	-2.34	0.00	±5	2024/3/15
5600	Head	22.7	5.000	35.300	5.07	35.50	-1.38	-0.56	±5	2024/3/16
5750	Head	22.5	5.170	35.100	5.22	35.40	-0.96	-0.85	±5	2024/3/17



12.3 System Performance Check Results

Comparing to the original SAR value provided by SPEAG, the verification data should be within its specification of 10 %. Below table shows the target SAR and measured SAR after normalized to 1W input power. The table below indicates the system performance check can meet the variation criterion and the plots can be referred to Appendix A of this report.

<1g SAR>

Date	Frequency (MHz)	Tissue Type	Input Power (mW)	Dipole S/N	Probe S/N	DAE S/N	Measured 1g SAR (W/kg)	Targeted 1g SAR (W/kg)	Normalized 1g SAR (W/kg)	Deviation (%)
2024/2/26	750	Head	50	1087	7764	1649	0.444	8.58	8.88	3.50
2024/2/27	835	Head	50	4d091	7764	1649	0.486	9.45	9.72	2.86
2024/2/28	1750	Head	50	1090	7764	1649	1.890	37.00	37.8	2.16
2024/2/29	1900	Head	50	5d118	7764	1649	2.070	39.30	41.4	5.34
2024/3/1	2600	Head	50	1070	7764	1649	2.820	56.20	56.4	0.36
2024/3/2	3500	Head	50	1037	7764	1649	3.310	65.40	66.2	1.22
2024/3/4	3700	Head	50	1008	7764	1649	3.460	67.20	69.2	2.98
2024/3/5	3900	Head	50	1048	7764	1649	3.420	69.10	68.4	-1.01
2024/3/6	750	Head	50	1087	7627	690	0.457	8.58	9.14	6.53
2024/3/7	835	Head	50	4d091	7627	690	0.502	9.45	10.04	6.24
2024/3/8	1750	Head	50	1090	7627	690	1.860	37.00	37.2	0.54
2024/3/9	1900	Head	50	5d118	7627	690	2.090	39.30	41.8	6.36
2024/3/10	2600	Head	50	1070	7627	690	2.830	56.20	56.6	0.71
2024/3/11	3500	Head	50	1037	7627	690	3.180	65.40	63.6	-2.75
2024/3/12	3700	Head	50	1008	7627	690	3.150	67.20	63	-6.25
2024/3/13	3900	Head	50	1048	7764	690	3.280	69.10	65.6	-5.07
2024/3/14	2450	Head	50	1040	7627	690	2.530	52.70	50.6	-3.98
2024/3/15	5250	Head	50	1113	7627	690	3.810	81.50	76.2	-6.50
2024/3/16	5600	Head	50	1113	7627	690	4.330	82.60	86.6	4.84
2024/3/17	5750	Head	50	1113	7627	690	4.220	80.80	84.4	4.46

<10g SAR>

Date	Frequency (MHz)	Tissue Type	Input Power (mW)	Dipole S/N	Probe S/N	DAE S/N	Measured 10g SAR (W/kg)	Targeted 10g SAR (W/kg)	Normalized 10g SAR (W/kg)	Deviation (%)
2024/2/26	750	Head	50	1087	7764	1649	0.297	5.65	5.94	5.13
2024/2/27	835	Head	50	4d091	7764	1649	0.322	6.22	6.44	3.54
2024/2/28	1750	Head	50	1090	7764	1649	0.993	19.50	19.86	1.85
2024/2/29	1900	Head	50	5d118	7764	1649	1.080	20.40	21.6	5.88
2024/3/1	2600	Head	50	1070	7764	1649	1.280	24.60	25.6	4.07
2024/3/2	3500	Head	50	1037	7764	1649	1.260	24.70	25.2	2.02
2024/3/4	3700	Head	50	1008	7764	1649	1.290	24.40	25.8	5.74
2024/3/5	3900	Head	50	1048	7764	1649	1.240	24.10	24.8	2.90
2024/3/6	750	Head	50	1087	7627	690	0.305	5.65	6.1	7.96
2024/3/7	835	Head	50	4d091	7627	690	0.335	6.22	6.7	7.72
2024/3/8	1750	Head	50	1090	7627	690	0.980	19.50	19.6	0.51
2024/3/9	1900	Head	50	5d118	7627	690	1.090	20.40	21.8	6.86
2024/3/10	2600	Head	50	1070	7627	690	1.290	24.60	25.8	4.88
2024/3/11	3500	Head	50	1037	7627	690	1.210	24.70	24.2	-2.02
2024/3/12	3700	Head	50	1008	7627	690	1.180	24.40	23.6	-3.28
2024/3/13	3900	Head	50	1048	7764	690	1.180	24.10	23.6	-2.07
2024/3/14	2450	Head	50	1040	7627	690	1.200	24.60	24	-2.44
2024/3/15	5250	Head	50	1113	7627	690	1.080	23.30	21.6	-7.30
2024/3/16	5600	Head	50	1113	7627	690	1.250	23.70	25	5.49
2024/3/17	5750	Head	50	1113	7627	690	1.210	23.00	24.2	5.22

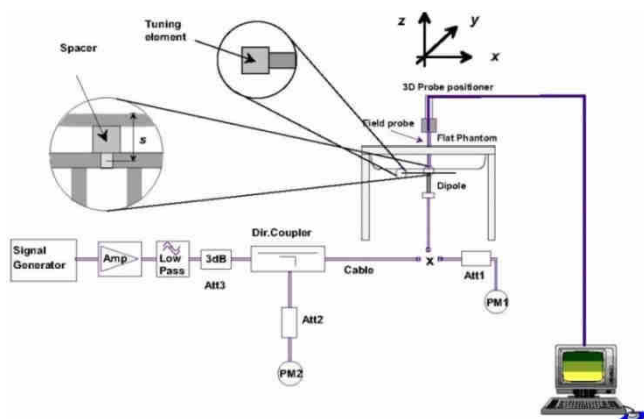

Fig 11.3.1 System Performance Check Setup



Fig 11.3.2 Setup Photo

13. RF Exposure Positions

13.1 Ear and handset reference point

Figure 12.1.1 shows the front, back, and side views of the SAM phantom. The center-of-mouth reference point is labeled “M,” the left ear reference point (ERP) is marked “LE,” and the right ERP is marked “RE.” Each ERP is 15 mm along the B-M (back-mouth) line behind the entrance-to-ear-canal (EEC) point, as shown in Figure 12.1.2 The Reference Plane is defined as passing through the two ear reference points and point M. The line N-F (neck-front), also called the reference pivoting line, is normal to the Reference Plane and perpendicular to both a line passing through RE and LE and the B-M line (see Figure 12.1.3). Both N-F and B-M lines should be marked on the exterior of the phantom shell to facilitate handset positioning. Posterior to the N-F line the ear shape is a flat surface with 6 mm thickness at each ERP, and forward of the N-F line the ear is truncated, as illustrated in Figure 12.1.2. The ear truncation is introduced to preclude the ear lobe from interfering with handset tilt, which could lead to unstable positioning at the cheek.

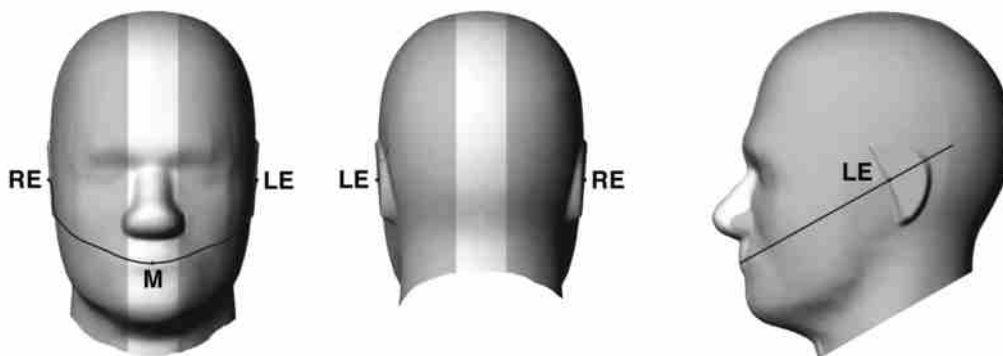

Fig 12.1.1 Front, back, and side views of SAM twin phantom

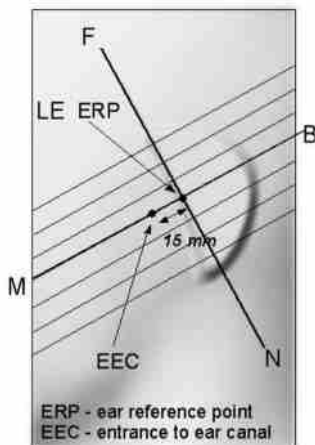

Fig 12.1.2 Close-up side view of phantom showing the ear region.

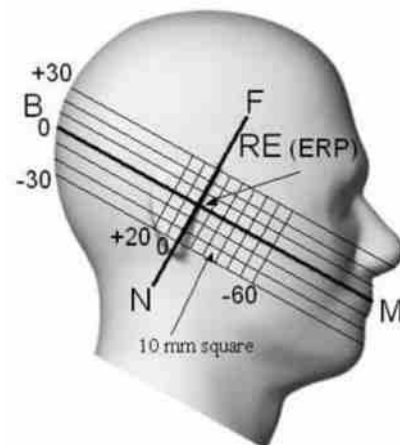

Fig 12.1.3 Side view of the phantom showing relevant markings and seven cross-sectional plane locations

13.2 Definition of the cheek position

1. Ready the handset for talk operation, if necessary. For example, for handsets with a cover piece (flip cover), open the cover. If the handset can transmit with the cover closed, both configurations must be tested.
2. Define two imaginary lines on the handset—the vertical centerline and the horizontal line. The vertical centerline passes through two points on the front side of the handset—the midpoint of the width w_t of the handset at the level of the acoustic output (point A in Figure 12.2.1 and Figure 12.2.2), and the midpoint of the width w_b of the bottom of the handset (point B). The horizontal line is perpendicular to the vertical centerline and passes through the center of the acoustic output (see Figure 12.2.1). The two lines intersect at point A. Note that for many handsets, point A coincides with the center of the acoustic output; however, the acoustic output may be located elsewhere on the horizontal line. Also note that the vertical centerline is not necessarily parallel to the front face of the handset (see Figure 12.2.2), especially for clamshell handsets, handsets with flip covers, and other irregularly-shaped handsets.
3. Position the handset close to the surface of the phantom such that point A is on the (virtual) extension of the line passing through points RE and LE on the phantom (see Figure 12.2.3), such that the plane defined by the vertical centerline and the horizontal line of the handset is approximately parallel to the sagittal plane of the phantom.
4. Translate the handset towards the phantom along the line passing through RE and LE until handset point A touches the pinna at the ERP.
5. While maintaining the handset in this plane, rotate it around the LE-RE line until the vertical centerline is in the plane normal to the plane containing B-M and N-F lines, i.e., the Reference Plane.
6. Rotate the handset around the vertical centerline until the handset (horizontal line) is parallel to the N-F line.
7. While maintaining the vertical centerline in the Reference Plane, keeping point A on the line passing through RE and LE, and maintaining the handset contact with the pinna, rotate the handset about the N-F line until any point on the handset is in contact with a phantom point below the pinna on the cheek. See Figure 12.2.3. The actual rotation angles should be documented in the test report.

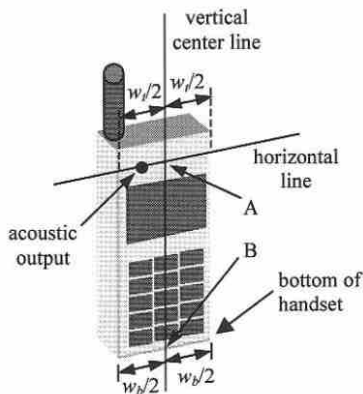

Fig 12.2.1 Handset vertical and horizontal reference lines—“fixed case”

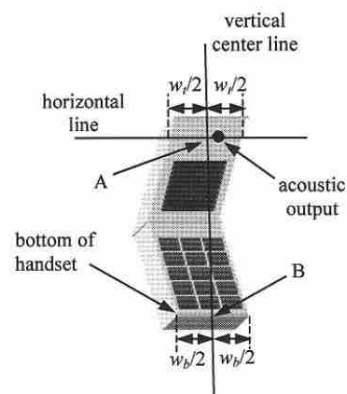

Fig 12.2.2 Handset vertical and horizontal reference lines—“clam-shell case”

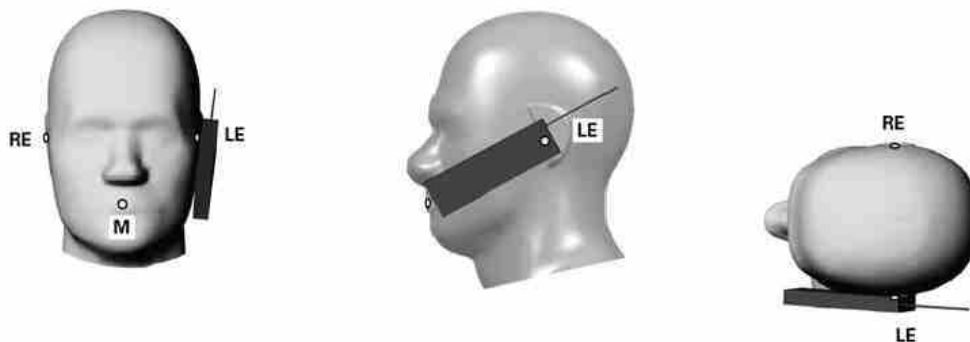

Fig 12.2.3 cheek or touch position. The reference points for the right ear (RE), left ear (LE), and mouth (M), which establish the Reference Plane for handset positioning, are indicated.

13.3 Definition of the tilt position

1. Ready the handset for talk operation, if necessary. For example, for handsets with a cover piece (flip cover), open the cover. If the handset can transmit with the cover closed, both configurations must be tested.
2. While maintaining the orientation of the handset, move the handset away from the pinna along the line passing through RE and LE far enough to allow a rotation of the handset away from the cheek by 15°.
3. Rotate the handset around the horizontal line by 15°.
4. While maintaining the orientation of the handset, move the handset towards the phantom on the line passing through RE and LE until any part of the handset touches the ear. The tilt position is obtained when the contact point is on the pinna. See Figure 12.3.1. If contact occurs at any location other than the pinna, e.g., the antenna at the back of the phantom head, the angle of the handset should be reduced. In this case, the tilt position is obtained if any point on the handset is in contact with the pinna and a second point

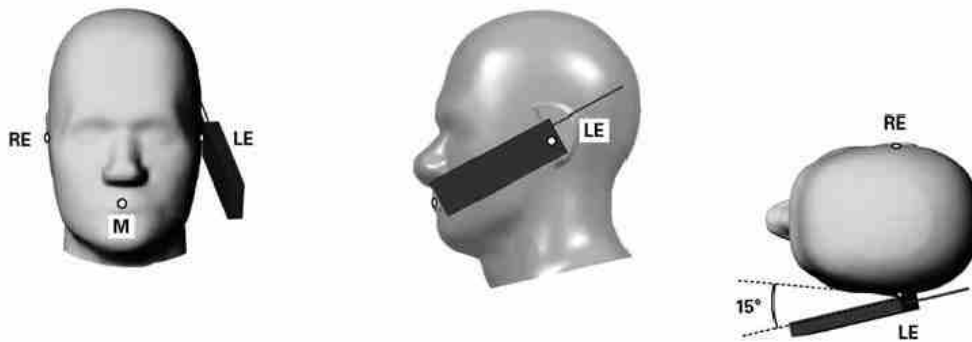

Fig 12.3.1 Tilt position. The reference points for the right ear (RE), left ear (LE), and mouth (M), which define the Reference Plane for handset positioning, are indicated.

13.4 Body Worn Accessory

Body-worn operating configurations are tested with the belt-clips and holsters attached to the device and positioned against a flat phantom in a normal use configuration (see Figure 11.4). Per KDB648474 D04v01r03, body-worn accessory exposure is typically related to voice mode operations when handsets are carried in body-worn accessories. The body-worn accessory procedures in FCC KDB 447498 D01v06 should be used to test for body-worn accessory SAR compliance, without a headset connected to it. This enables the test results for such configuration to be compatible with that required for hotspot mode when the body-worn accessory test separation distance is greater than or equal to that required for hotspot mode, when applicable. When the reported SAR for body-worn accessory, measured without a headset connected to the handset is > 1.2 W/kg, the highest reported SAR configuration for that wireless mode and frequency band should be repeated for that body-worn accessory with a headset attached to the handset.

Accessories for body-worn operation configurations are divided into two categories: those that do not contain metallic components and those that do contain metallic components. When multiple accessories that do not contain metallic components are supplied with the device, the device is tested with only the accessory that dictates the closest spacing to the body. Then multiple accessories that contain metallic components are test with the device with each accessory. If multiple accessories share an identical metallic component (i.e. the same metallic belt-chip used with different holsters with no other metallic components) only the accessory that dictates the closest spacing to the body is tested.

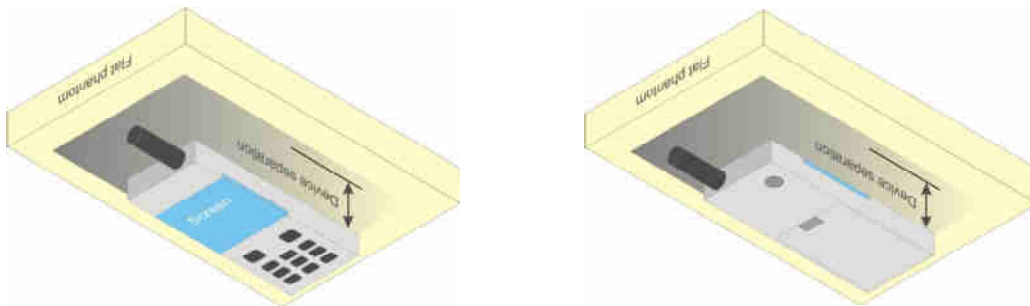

Fig 12.4 Body Worn Position

13.5 Product Specific 10g SAR Exposure

For smart phones with a display diagonal dimension > 15.0 cm or an overall diagonal dimension > 16.0 cm, that can provide similar mobile web access and multimedia support found in mini-tablets or UMPC mini-tablets and support voice calls next to the ear, According to KDB648474 D04v01r03, the following phablet procedures should be applied to evaluate SAR compliance for each applicable wireless modes and frequency band. Devices marketed as phablets, regardless of form factors and operating characteristics must be tested as a phablet to determine SAR compliance

1. The normally required head and body-worn accessory SAR test procedures for handsets, including hotspot mode, must be applied.
2. The UMPC mini-tablet procedures must also be applied to test the SAR of all surfaces and edges with an antenna located at ≤ 25 mm from that surface or edge, in direct contact with a flat phantom, for 10-g extremity SAR according to the body-equivalent tissue dielectric parameters in KDB 865664 to address interactive hand use exposure conditions.6 The UMPC mini-tablet 1-g SAR at 5 mm is not required. When hotspot mode applies, 10-g extremity SAR is required only for the surfaces and edges with hotspot mode 1-g reported SAR > 1.2 W/kg.

13.6 Wireless Router

Some battery-operated handsets have the capability to transmit and receive user through simultaneous transmission of WIFI simultaneously with a separate licensed transmitter. The FCC has provided guidance in FCC KDB Publication 941225 D06 v02r01 where SAR test considerations for handsets ($L \times W \geq 9$ cm x 5 cm) are based on a composite test separation distance of 10mm from the front, back and edges of the device containing transmitting antennas within 2.5cm of their edges, determined from general mixed use conditions for this type of devices. Since the hotspot SAR results may overlap with the body-worn accessory SAR requirements, the more conservative configurations can be considered, thus excluding some body-worn accessory SAR tests.

When the user enables the personal wireless router functions for the handset, actual operations include simultaneous transmission of both the WIFI transmitter and another licensed transmitter. Both transmitters often do not transmit at the same transmitting frequency and thus cannot be evaluated for SAR under actual use conditions due to the limitations of the SAR assessment probes. Therefore, SAR must be evaluated for each frequency transmission and mode separately and spatially summed with the WIFI transmitter according to FCC KDB Publication 447498 D01v06 publication procedures. The "Portable Hotspot" feature on the handset was NOT activated during SAR assessments, to ensure the SAR measurements were evaluated for a single transmission frequency RF signal at a time.

14. Conducted RF Output Power (Unit: dBm)

The detailed conducted power table can refer to Appendix E.

<GSM Conducted Power>

1. Per KDB 447498 D01v06, the maximum output power channel is used for SAR testing and for further SAR test reduction.
2. Per KDB 941225 D01v03r01, for SAR test reduction for GSM / GPRS / EDGE modes is determined by the source-based time-averaged output power including tune-up tolerance. The mode with highest specified time-averaged output power should be tested for SAR compliance in the applicable exposure conditions. For modes with the same specified maximum output power and tolerance, the higher number time-slot configuration should be tested.
3. Other configurations of GSM / GPRS / EDGE are considered as secondary modes. The 3G SAR test reduction procedure is applied, when the maximum output power and tune-up tolerance specified for production units in a secondary mode is $\leq \frac{1}{4}$ dB higher than the primary mode, SAR measurement is not required for the secondary mode.

<WCDMA Conducted Power>

1. The following tests were conducted according to the test requirements outlines in 3GPP TS 34.121 specification.
2. The procedures in KDB 941225 D01v03r01 are applied for 3GPP Rel. 6 HSPA to configure the device in the required sub-test mode(s) to determine SAR test exclusion.
3. For DC-HSDPA, the device was configured according to the H-Set 12, Fixed Reference Channel (FRC) configuration in Table C.8.1.12 of 3GPP TS 34.121-1, with the primary and the secondary serving HS-DSCH Cell enabled during the power measurement.

A summary of these settings are illustrated below:

HSDPA Setup Configuration:

- a. The EUT was connected to Base Station Agilent E5515C referred to the Setup Configuration.
- b. The RF path losses were compensated into the measurements.
- c. A call was established between EUT and Base Station with following setting:
 - i. Set Gain Factors (β_c and β_d) and parameters were set according to each
 - ii. Specific sub-test in the following table, C10.1.4, quoted from the TS 34.121
 - iii. Set RMC 12.2Kbps + HSDPA mode.
 - iv. Set Cell Power = -86 dBm
 - v. Set HS-DSCH Configuration Type to FRC (H-set 1, QPSK)
 - vi. Select HSDPA Uplink Parameters
 - vii. Set Delta ACK, Delta NACK and Delta CQI = 8
 - viii. Set Ack-Nack Repetition Factor to 3
 - ix. Set CQI Feedback Cycle (k) to 4 ms
 - x. Set CQI Repetition Factor to 2
 - xi. Power Ctrl Mode = All Up bits
- d. The transmitted maximum output power was recorded.

Table C.10.1.4: β values for transmitter characteristics tests with HS-DPCCH

Sub-test	β_c	β_d	β_d (SF)	β_o/β_d	β_{HS} (Note 1, Note 2)	CM (dB) (Note 3)	MPR (dB) (Note 3)
1	2/15	15/15	64	2/15	4/15	0.0	0.0
2	12/15 (Note 4)	15/15 (Note 4)	64	12/15 (Note 4)	24/15	1.0	0.0
3	15/15	8/15	64	15/8	30/15	1.5	0.5
4	15/15	4/15	64	15/4	30/15	1.5	0.5

Note 1: Δ_{ACK} , Δ_{NACK} and $\Delta_{CQI} = 30/15$ with $\beta_{HS} = 30/15 * \beta_c$.

Note 2: For the HS-DPCCH power mask requirement test in clause 5.2C, 5.7A, and the Error Vector Magnitude (EVM) with HS-DPCCH test in clause 5.13.1A, and HSDPA EVM with phase discontinuity in clause 5.13.1AA, Δ_{ACK} and $\Delta_{NACK} = 30/15$ with $\beta_{HS} = 30/15 * \beta_c$, and $\Delta_{CQI} = 24/15$ with $\beta_{HS} = 24/15 * \beta_c$.

Note 3: CM = 1 for $\beta_o/\beta_d = 12/15$, $\beta_{HS}/\beta_c = 24/15$. For all other combinations of DPDCH, DPCCH and HS-DPCCH the MPR is based on the relative CM difference. This is applicable for only UEs that support HSDPA in release 6 and later releases.

Note 4: For subtest 2 the β_o/β_d ratio of 12/15 for the TFC during the measurement period (TF1, TF0) is achieved by setting the signalled gain factors for the reference TFC (TF1, TF1) to $\beta_c = 11/15$ and $\beta_d = 15/15$.

Setup Configuration

HSUPA Setup Configuration:

- a. The EUT was connected to Base Station Agilent E5515C referred to the Setup Configuration.
- b. The RF path losses were compensated into the measurements.
- c. A call was established between EUT and Base Station with following setting * :
 - i. Call Configs = 5.2B, 5.9B, 5.10B, and 5.13.2B with QPSK
 - ii. Set the Gain Factors (β_c and β_d) and parameters (AG Index) were set according to each specific sub-test in the following table, C11.1.3, quoted from the TS 34.121
 - iii. Set Cell Power = -86 dBm
 - iv. Set Channel Type = 12.2k + HSPA
 - v. Set UE Target Power
 - vi. Power Ctrl Mode= Alternating bits
 - vii. Set and observe the E-TFCI
 - viii. Confirm that E-TFCI is equal to the target E-TFCI of 75 for sub-test 1, and other subtest's E-TFCI
- d. The transmitted maximum output power was recorded.

Table C.11.1.3: β values for transmitter characteristics tests with HS-DPCCH and E-DCH

Sub-test	β_c	β_d	β_{sf} (SF)	β_c/β_d	β_{HS} (Note1)	β_{ec}	β_{ed} (Note 4) (Note 5)	β_{ed} (SF)	β_{ed} (Codes)	CM (dB) (Note 2)	MPR (dB) (Note 2) (Note 6)	AG Index (Note 5)	E-TFCI
1	11/15 (Note 3)	15/15 (Note 3)	64	11/15 (Note 3)	22/15	209/25	1309/225	4	1	1.0	0.0	20	75
2	6/15	15/15	64	6/15	12/15	12/15	94/75	4	1	3.0	2.0	12	67
3	15/15	9/15	64	15/9	30/15	30/15	β_{ed1} : 47/15 β_{ed2} : 47/15	4	2	2.0	1.0	15	92
4	2/15	15/15	64	2/15	4/15	2/15	56/75	4	1	3.0	2.0	17	71
5	15/15	0	-	-	5/15	5/15	47/15	4	1	1.0	0.0	12	67

Note 1: For sub-test 1 to 4, Δ_{ACK} , Δ_{NACK} and $\Delta_{CDI} = 30/15$ with $\beta_{HS} = 30/15 * \beta_c$. For sub-test 5, Δ_{ACK} , Δ_{NACK} and $\Delta_{CDI} = 5/15$ with $\beta_{HS} = 5/15 * \beta_c$.

Note 2: CM = 1 for $\beta_c/\beta_d = 12/15$, $\beta_{HS}/\beta_c = 24/15$. For all other combinations of DPDCH, DPCCH, HS-DPCCH, E-DPDCH and E-DPCCH the MPR is based on the relative CM difference.

Note 3: For subtest 1 the β_c/β_d ratio of 11/15 for the TFC during the measurement period (TF1, TF0) is achieved by setting the signalled gain factors for the reference TFC (TF1, TF0) to $\beta_c = 10/15$ and $\beta_d = 15/15$.

Note 4: In case of testing by UE using E-DPDCH Physical Layer category 1, Sub-test 3 is omitted according to TS25.306 Table 5.1g.

Note 5: β_{ed} can not be set directly; it is set by Absolute Grant Value.

Note 6: For subtests 2, 3 and 4, UE may perform E-DPDCH power scaling at max power which could results in slightly smaller MPR values.

Setup Configuration

DC-HSDPA 3GPP release 8 Setup Configuration:

- a. The EUT was connected to Base Station Agilent E5515C referred to the Setup Configuration below
- b. The RF path losses were compensated into the measurements.
- c. A call was established between EUT and Base Station with following setting:
 - i. Set RMC 12.2Kbps + HSDPA mode.
 - ii. Set Cell Power = -25 dBm
 - iii. Set HS-DSCH Configuration Type to FRC (H-set 12, QPSK)
 - iv. Select HSDPA Uplink Parameters
 - v. Set Gain Factors (β_c and β_d) and parameters were set according to each Specific sub-test in the following table, C10.1.4, quoted from the TS 34.121
 - a). Subtest 1: $\beta_c/\beta_d=2/15$
 - b). Subtest 2: $\beta_c/\beta_d=12/15$
 - c). Subtest 3: $\beta_c/\beta_d=15/8$
 - d). Subtest 4: $\beta_c/\beta_d=15/4$
 - vi. Set Delta ACK, Delta NACK and Delta CQI = 8
 - vii. Set Ack-Nack Repetition Factor to 3
 - viii. Set CQI Feedback Cycle (k) to 4 ms
 - ix. Set CQI Repetition Factor to 2
 - x. Power Ctrl Mode = All Up bits
- d. The transmitted maximum output power was recorded.

The following tests were conducted according to the test requirements outlines in 3GPP TS 34.121 specification. A summary of these settings are illustrated below:

C.8.1.12 Fixed Reference Channel Definition H-Set 12

Table C.8.1.12: Fixed Reference Channel H-Set 12

Parameter	Unit	Value
Nominal Avg. Inf. Bit Rate	kbps	60
Inter-TTI Distance	TTI's	1
Number of HARQ Processes	Processes	6
Information Bit Payload (N_{INF})	Bits	120
Number Code Blocks	Blocks	1
Binary Channel Bits Per TTI	Bits	960
Total Available SML's in UE	SML's	19200
Number of SML's per HARQ Proc.	SML's	3200
Coding Rate		0.15
Number of Physical Channel Codes	Codes	1
Modulation		QPSK
Note 1: The RMC is intended to be used for DC-HSDPA mode and both cells shall transmit with identical parameters as listed in the table. Note 2: Maximum number of transmission is limited to 1, i.e., retransmission is not allowed. The redundancy and constellation version 0 shall be used.		

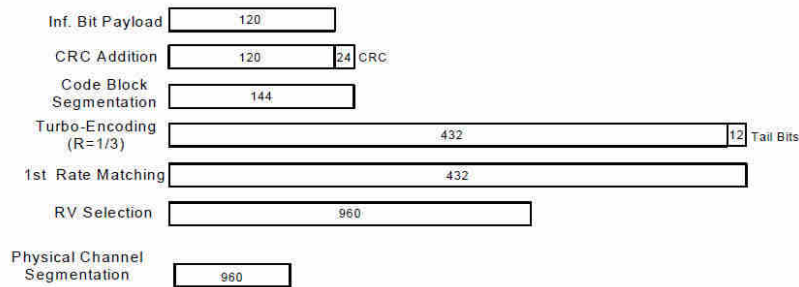

Figure C.8.19: Coding rate for Fixed reference Channel H-Set 12 (QPSK)

Setup Configuration



<WCDMA Conducted Power>

General Note:

1. Per KDB 941225 D01v03r01, for SAR testing is measured using a 12.2 kbps RMC with TPC bits configured to all "1's".
2. Per KDB 941225 D01v03r01, RMC 12.2kbps setting is used to evaluate SAR. The maximum output power and tune-up tolerance specified for production units in HSDPA / HSUPA/ DC-HSDPA is $\leq \frac{1}{4}$ dB higher than RMC 12.2Kbps or when the highest reported SAR of the RMC12.2Kbps is scaled by the ratio of specified maximum output power and tune-up tolerance of HSDPA / HSUPA/ DC-HSDPA to RMC12.2Kbps and the adjusted SAR is ≤ 1.2 W/kg, SAR measurement is not required for HSDPA / HSUPA/ DC-HSDPA, and according to the following RF output power, the output power results of the secondary modes (HSDPA / HSUPA/ DC-HSDPA) are less than $\frac{1}{4}$ dB higher than the primary modes; therefore, SAR measurement is not required for HSDPA / HSUPA/ DC-HSDPA.

<LTE Conducted Power>

General Note:

1. Anritsu MT8820C base station simulator was used to setup the connection with EUT; the frequency band, channel bandwidth, RB allocation configuration, modulation type are set in the base station simulator to configure EUT transmitting at maximum power and at different configurations which are requested to be reported to FCC, for conducted power measurement and SAR testing.
2. Per KDB 941225 D05v02r05, when a properly configured base station simulator is used for the SAR and power measurements, spectrum plots for each RB allocation and offset configuration is not required.
3. Per KDB 941225 D05v02r05, start with the largest channel bandwidth and measure SAR for QPSK with 1 RB allocation, using the RB offset and required test channel combination with the highest maximum output power for RB offsets at the upper edge, middle and lower edge of each required test channel.
4. Per KDB 941225 D05v02r05, 50% RB allocation for QPSK SAR testing follows 1RB QPSK allocation procedure.
5. Per KDB 941225 D05v02r05, for QPSK with 100% RB allocation, SAR is not required when the highest maximum output power for 100 % RB allocation is less than the highest maximum output power in 50% and 1 RB allocations and the highest reported SAR for 1 RB and 50% RB allocation are ≤ 0.8 W/kg. Otherwise, SAR is measured for the highest output power channel; and if the reported SAR is > 1.45 W/kg, the remaining required test channels must also be tested.
6. Per KDB 941225 D05v02r05, 16QAM/64QAM/256QAM output power for each RB allocation configuration is $>$ not $\frac{1}{2}$ dB higher than the same configuration in QPSK and the reported SAR for the QPSK configuration is ≤ 1.45 W/kg; Per KDB 941225 D05v02r05, 16QAM/64QAM/256QAM SAR testing is not required.
7. Per KDB 941225 D05v02r05, smaller bandwidth output power for each RB allocation configuration is $>$ not $\frac{1}{2}$ dB higher than the same configuration in the largest supported bandwidth, and the reported SAR for the largest supported bandwidth is ≤ 1.45 W/kg; Per KDB 941225 D05v02r05, smaller bandwidth SAR testing is not required.
8. For LTE B4 / B5 / B12 / B17 / B26 / B38 the maximum bandwidth does not support three non-overlapping channels, per KDB 941225 D05v02r05, when a device supports overlapping channel assignment in a channel bandwidth configuration, the middle channel of the group of overlapping channels should be selected for testing.
9. LTE B2 /B4 /B5 / B17 / B38 SAR test was covered by B25 / B66 / B26 / B12 / B41; according to April 2015 TCB workshop, SAR test for overlapping LTE bands can be reduced if
 - a. the maximum output power, including tolerance, for the smaller band is \leq the larger band to qualify for the SAR test exclusion
 - b. the channel bandwidth and other operating parameters for the smaller band are fully supported by the larger band
10. According to May 2017 TCB workshop, for 16QAM and 64QAM, 256QAM should be verified by checking the signal constellation with a call box to avoid incorrect maximum power levels due to MPR and other requirements associated with signal modulation, and the following figure is taken from the "Fundamental Measurement >> Modulation Analysis >> constellation" mode of the device connect to the MT8821C base station, therefore, the device 256QAM, 64QAM and 16QAM signal modulation are correct.

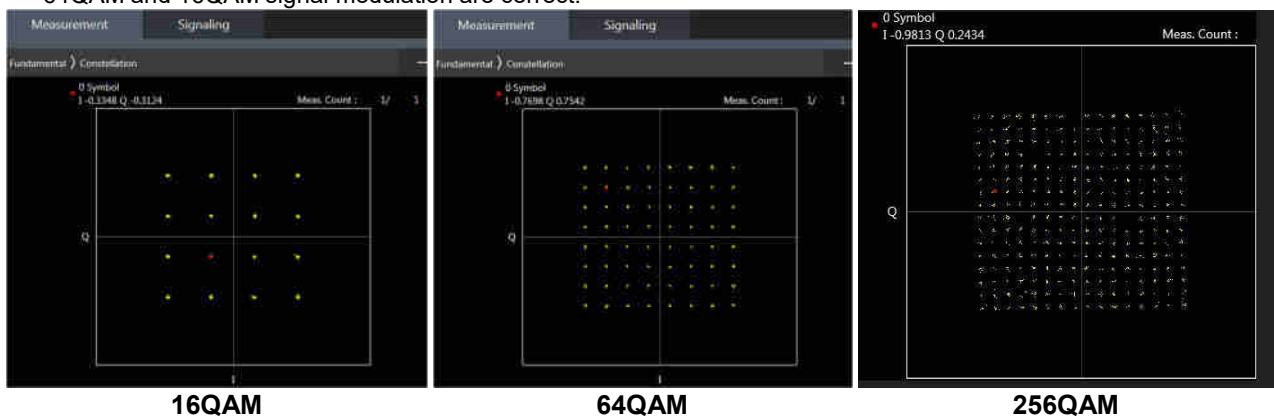

<TDD LTE SAR Measurement>

TDD LTE configuration setup for SAR measurement

SAR was tested with a fixed periodic duty factor according to the highest transmission duty factor implemented for the device and supported by 3GPP.

- a. 3GPP TS 36.211 section 4.2 for Type 2 Frame Structure and Table 4.2-2 for uplink-downlink configurations
- b. "special subframe S" contains both uplink and downlink transmissions, it has been taken into consideration to determine the transmission duty factor according to the worst case uplink and downlink cyclic prefix requirements for UpPTS
- c. Establishing connections with base station simulators ensure a consistent means for testing SAR and recommended for evaluating SAR. The Anritsu MT8820C (firmware: #22.52#004) was used for LTE output power measurements and SAR testing.

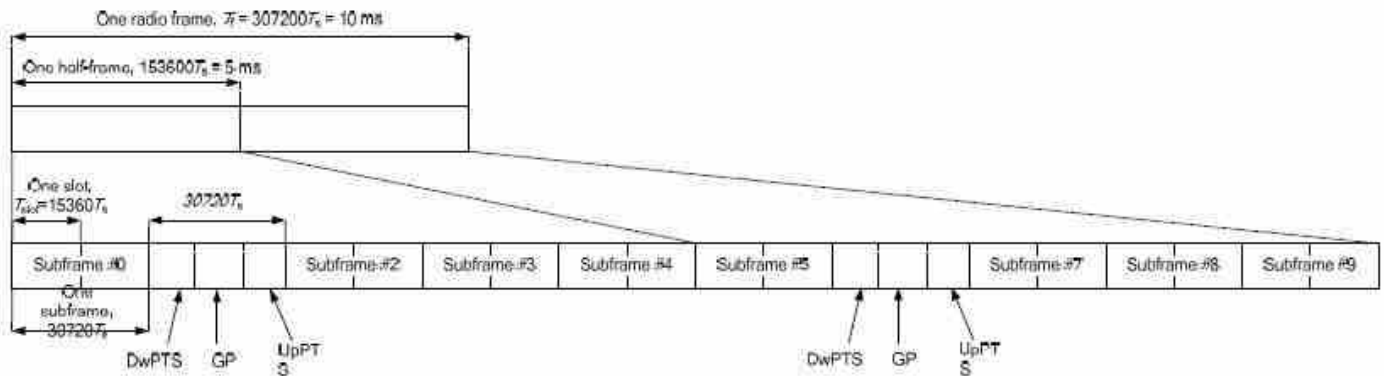

Figure 4.2-1: Frame structure type 2 (for 5 ms switch-point periodicity).

Table 4.2-2: Uplink-downlink configurations.

Uplink-downlink configuration	Downlink-to-Uplink Switch-point periodicity	Subframe number									
		0	1	2	3	4	5	6	7	8	9
0	5 ms	D	S	U	U	U	D	S	U	U	U
1	5 ms	D	S	U	U	D	D	S	U	U	D
2	5 ms	D	S	U	D	D	D	S	U	D	D
3	10 ms	D	S	U	U	U	D	D	D	D	D
4	10 ms	D	S	U	U	D	D	D	D	D	D
5	10 ms	D	S	U	D	D	D	D	D	D	D
6	5 ms	D	S	U	U	D	S	U	U	D	D

Table 4.2-1: Configuration of special subframe (lengths of DwPTS/GP/UpPTS).

Special subframe configuration	Normal cyclic prefix in downlink				Extended cyclic prefix in downlink		
	DwPTS	UpPTS		DwPTS	UpPTS		
		Normal cyclic prefix in uplink	Extended cyclic prefix in uplink		Normal cyclic prefix in uplink	Extended cyclic prefix in uplink	
0	6592 · Ts	2192 · Ts	2560 · Ts	7680 · Ts	2192 · Ts	2560 · Ts	
1	19760 · Ts			20480 · Ts			
2	21952 · Ts			23040 · Ts			
3	24144 · Ts			25600 · Ts			
4	26336 · Ts	4384 · Ts	5120 · Ts	7680 · Ts	4384 · Ts	5120 · Ts	
5	6592 · Ts			20480 · Ts			
6	19760 · Ts			23040 · Ts			
7	21952 · Ts			12800 · Ts			
8	24144 · Ts			-			-
9	13168 · Ts	-	-	-	-	-	



Special subframe (30720·T _s): Normal cyclic prefix in downlink (UpPTS)			
	Special subframe configuration	Normal cyclic prefix in uplink	Extended cyclic prefix in uplink
Uplink duty factor in one special subframe	0~4	7.13%	8.33%
	5~9	14.3%	16.7%

Special subframe(30720·T _s): Extended cyclic prefix in downlink (UpPTS)			
	Special subframe configuration	Normal cyclic prefix in uplink	Extended cyclic prefix in uplink
Uplink duty factor in one special subframe	0~3	7.13%	8.33%
	4~7	14.3%	16.7%

The highest duty factor is resulted from:

For LTE TDD Power class 2

- i. Uplink-downlink configuration: 1. In a half-frame consisted of 5 subframes, uplink operation is in 2 uplink subframes and 1 special subframe.
- ii. special subframe configuration: 5-9 for normal cyclic prefix in downlink, 4-7 for extended cyclic prefix in downlink
- iii. for special subframe with extended cyclic prefix in uplink, the total uplink duty factor in one half-frame is: $(2+0.167)/5 = 43.3\%$
- iv. for special subframe with normal cyclic prefix in uplink, the total uplink duty factor in one half-frame is: $(2+0.143)/5 = 42.9\%$
- v. For TDD LTE SAR measurement, the duty cycle 1:2.33 (42.9 %) was used perform testing and considering the theoretical duty cycle of 43.3% for extended cyclic prefix in the uplink, and the theoretical duty cycle of 42.9% for normal cyclic prefix in uplink, a scaling factor of extended cyclic prefix $43.3\%/42.9\% = 1.009$ is applied to scale-up the measured SAR result. The scaled TDD LTE SAR = measured SAR (W/kg)* Tune-up Scaling Factor* scaling factor for extended cyclic prefix.

For LTE TDD Power class 3

- i. Uplink-downlink configuration: 0. In a half-frame consisted of 5 subframes, uplink operation is in 3 uplink subframes and 1 special subframe.
- ii. special subframe configuration: 5-9 for normal cyclic prefix in downlink, 4-7 for extended cyclic prefix in downlink
- iii. for special subframe with extended cyclic prefix in uplink, the total uplink duty factor in one half-frame is: $(3+0.167)/5 = 63.3\%$
- iv. for special subframe with normal cyclic prefix in uplink, the total uplink duty factor in one half-frame is: $(3+0.143)/5 = 62.9\%$
- v. For TDD LTE SAR measurement, the duty cycle 1:1.59 (62.9 %) was used perform testing and considering the theoretical duty cycle of 63.3% for extended cyclic prefix in the uplink, and the theoretical duty cycle of 62.9% for normal cyclic prefix in uplink, a scaling factor of extended cyclic prefix $63.3\%/62.9\% = 1.006$ is applied to scale-up the measured SAR result. The scaled TDD LTE SAR = measured SAR (W/kg)* Tune-up Scaling Factor* scaling factor for extended cyclic prefix.

The device can adjust uplink/downlink configuration automatically according to the transmitting power class level, as followings:

LTE TDD Band	Power Class level	support uplink/downlink configuration
LTE Band 41	> 23	1,2,3,4,5
	=23	0,1,2,3,4,5,6
	< 23	0,1,2,3,4,5,6



<LTE Carrier Aggregation>

General Note:

1. This device supports Carrier Aggregation on downlink for inter and intra band. For the device supports bands and bandwidths and configurations are provided as follow table was according to 3GPP.
2. In applying the existing power measurement procedures of KDB 941225 D05A for DL CA SAR test exclusion, only the subset with the largest number of combinations of frequency bands and CCs in each row need combination, and for this device that all the configurations were choose to power measurement.
3. The gray color table is covered by other combinations and no need to verify power.

2CC Downlink Carrier Aggregation				3CC Downlink Carrier Aggregation				4CC Downlink Carrier Aggregation				5CC Downlink Carrier Aggregation			
Number	Combination	4X4 MIMO	Covered by Measurement Superset	Number	Combination	4X4 MIMO	Covered by Measurement Superset	Number	Combination	4X4 MIMO	Covered by Measurement Superset	Number	Combination	4X4 MIMO	Covered by Measurement Superset
1	CA_2A-2A	2A	3CC-2	1	CA_26A-41C	41C, 41A		1	CA_2A-2A-4A-5A	4A, 2A		1	CA_5A-7C-66A-66A	7C,7A, 66A	
2	CA_2A-4A	4A, 2A	3CC-4	2	CA_2A-2A-5A	2A	4CC-1	2	CA_2A-4A-7C	7C, 7A, 4A, 2A		2	CA_41C-41D	41D, 41C, 41A	
3	CA_2A-5A	2A	3CC-4	3	CA_2A-2A-7A	7A, 2A		3	CA_2A-7C-38A	7C, 7A, 38A, 2A		3	CA_41F		
4	CA_2A-7A	7A, 2A	3CC-5	4	CA_2A-4A-5A	4A, 2A	4CC-1	4	CA_41A-41A-41C	41C, 41A					
5	CA_2A-26A	2A		5	CA_2A-4A-7A	7A, 4A, 2A		5	CA_41A-41D	41D,41C, 41A					
6	CA_2A-38A	38A, 2A	3CC-7	6	CA_2A-5A-7A	7A, 2A		6	CA_41C-41C	41C, 41A					
7	CA_2C	2C, 2A		7	CA_2A-7A-38A	7A, 38A, 2A		7	CA_41C-42C	42C, 41C, 42A, 41A					
8	CA_38C	38C, 38A		8	CA_2A-7A-7A	7A, 2A		8	CA_41E	41E, 41D, 41C, 41A					
9	CA_41A-41A	41A	3CC-19	9	CA_2A-7A-66A	7A, 66A, 2A		9	CA_42E	42E, 42D, 42C, 42A					
10	CA_41A-42A	42A, 41A		10	CA_2A-7C	7C, 7A, 2A	4CC-2	10	CA_5A-7A-66A-66A	7A, 66A					
11	CA_41C	41C, 41A	3CC-20	11	CA_4A-4A-7A	7A, 4A		11	CA_5A-7C-66A	7C, 7A, 66A	5CC-1				
12	CA_42A-42A	42A		12	CA_4A-7C	7C, 7A, 4A	4CC-2	12	CA_7C-66A-66A	7C, 7A, 66A	5CC-1				
13	CA_42C	42C, 42A	3CC-21	14	CA_5A-66A-66A	66A	4CC-10								
14	CA_4A-4A	4A	3CC-11	15	CA_5A-7A-66A	7A, 66A	4CC-10								
15	CA_4A-5A	4A	3CC-4	16	CA_5A-7C	7C, 7A	4CC-11								
16	CA_4A-7A	7A, 4A	3CC-5	17	CA_7A-26A-66A	7A, 66A									
17	CA_5A-66A	66A	3CC-14	18	CA_7A-66A-66A	7A, 66A	4CC-10								
18	CA_5A-7A	7A	3CC-6	19	CA_41A-41A-41A	41A									
19	CA_66A-66A	66A	3CC-14	20	CA_41A-41C	41C, 41A	4CC-4								
20	CA_66B	66B, 66A		21	CA_41A-42C	42C,42A, 41A									
21	CA_66C	66C, 66A		22	CA_41C-42A	41C, 42A, 41A									
22	CA_7A-7A	7A	3CC-8	23	CA_41D	41D, 41C, 41A									
23	CA_7A-26A	7A	3CC-17	24	CA_42D	42D, 42C, 42A									
24	CA_7A-42A	7A, 42A													
25	CA_7A-66A	7A, 66A	3CC-17												
26	CA_7B	7B, 7A													
27	CA_7C	7C, 7A													

LTE Carrier Aggregation Conducted Power (Downlink)

- i. According to KDB941225 D05A v01r02, Uplink maximum output power measurement with downlink carrier aggregation active should be measured, using the highest output channel measured without downlink carrier aggregation, to confirm that uplink maximum output power with downlink carrier aggregation active remains within the specified tune-up tolerance limits and not more than ¼ dB higher than the maximum output measured without downlink carrier aggregation active.
- ii. Uplink maximum output power with downlink carrier aggregation active does not show more than ¼ dB higher than the maximum output power without downlink carrier aggregation active, therefore SAR evaluation with downlink carrier aggregation active can be excluded.
- iii. The device supports downlink five carrier aggregation. For power measurement were control and acknowledge data is sent on uplink channels that operate identical to specifications when downlink carrier aggregation is inactive.
- iv. Selected highest measured power when downlink carrier aggregation is inactive for conducted power comparison with downlink carrier aggregation is active, to confirm that when downlink carrier aggregation is active uplink maximum output power remains within the specified tune-up tolerance limits and not more than ¼ dB higher than the maximum output power measured when downlink carrier aggregation inactive.
- v. For inter-band CA, the SCC selected highest bandwidth and near the middle of its transmission band. For SCC DL RB size and offset will base on the PCC corresponding RB allocation.
- vi. For non-contiguous intra-band CA, the SCC selected to provide maximum separation from the PCC and must remain fully within the downlink transmission band.
- vii. For Intra-band, contiguous CA, the downlink channels selected to perform the uplink power measurement must satisfy 3GPP channel spacing (5.4.1A of 3GPP TS 36.521 or equivalent) and channel bandwidth (5.4.2A) requirements.

$$\text{Nominal channel spacing} = \left\lceil \frac{BW_{\text{Channel}(1)} + BW_{\text{Channel}(2)} - 0.1|BW_{\text{Channel}(1)} - BW_{\text{Channel}(2)}|}{0.6} \right\rceil 0.3 \text{ [MHz]}$$

LTE 4x4 MIMO (Downlink)

This device supports downlink 4x4 MIMO operations for LTE Band 2/4/7/38/41/42/66 only. Uplink transmission is limited to a single output stream. Power measurements were performed with downlink 4x4 MIMO active for the configuration with highest measured maximum conducted power with 4x4 downlink MIMO inactive measured among the channel bandwidth, modulation, and RB combinations in each frequency band.

Per FCC Guidance, SAR for downlink 4x4 MIMO was not needed since the maximum average output power in 4x4 downlink MIMO mode was not > 0.25 dB higher than the maximum output power with downlink 4x4 MIMO inactive. When carrier aggregation is applicable, power measurements were performed with the downlink carrier aggregation and 4x4 DL MIMO active for the configuration with highest measured maximum conducted power with downlink carrier aggregation inactive measured among the channel bandwidth, modulation, and RB combinations in each frequency band.

4X4 MIMO	Band
	LTE Band 2/4/7/38/41/42/66



LTE Carrier Aggregation Conducted Power (Uplink)

LTE Uplink CA	2CC Uplink Carrier Aggregation
Intra-band	Antenna Tx
CA_7C	Ant0/1/2/3
CA_38C	Ant0/1/2/3
CA_41C	Ant0/1/2/3
CA_42C	Ant7

<Intra-band>

General Note:

- i. The device supports intra-band uplink carrier aggregation for LTE B7/38/41/42 with a maximum of two uplink component carriers. For intra band contiguous carrier aggregation scenarios, 3GPP 36.101 table 6.2.2A-1 specifies that the aggregate maximum allowed output power is equivalent to the single carrier scenario. 3GPP 36.101 6.2.3A allows for several dB of MPR to be applied when not-contiguous RB allocation is implemented. The conducted power and MPR setting in this device are permanently implemented pre 3GPP requirement.
- ii. The device supports uplink carrier aggregation with a maximum of two uplink component carriers. For intra band contiguous carrier aggregation scenarios, 3GPP 36.101 table 6.2.2A-1 specifies that the aggregate maximum allowed output power is equivalent to the single carrier scenario. 3GPP 36.101 6.2.3A allows for several dB of MPR to be applied when not-contiguous RB allocation is implemented. The conducted power and MPR setting in this device are permanently implemented pre the 3GPP requirement.
- iii. According Nov. 2017 TCB workshop, the output power with uplink CA active was measured for the configuration with the highest reported SAR with single carrier for each exposure condition. The power was measured with wideband signal integration over both component carriers.
- iv. Additional SAR measurement for LTE UL CA with other DL CA combinations active were not required since the maximum output power for this configuration was not > 0.25dB higher than the maximum output power for UL CA active.

<Inter-band uplink carrier aggregation consideration>

LTE Uplink CA	2CC Uplink Carrier Aggregation	
Inter-band	LTE Tx	LTE Tx
CA_2A-4A	Ant1/2	Ant1/2
CA_2A-7A	Ant1/2	Ant1/2
CA_4A-5A	Ant1/2	Ant0/1
CA_4A-7A	Ant1/2	Ant1/2
CA_5A-66A	Ant0/1	Ant1/2
CA_5A-7A	Ant0/1	Ant0/1/2/3

General Note:

1. The single carrier of inter band CA uplink power level is the same as Non-CA standalone LTE power level.
2. The product implements Qualcomm Smart Transmit feature which controls the instantaneous transmitting power for WWAN transmitter to ensure the product in compliance with FCC RF exposure limit over a defined time window. To control and manage transmitting power in real time and to ensure at all times the time-averaged RF exposure is compliant to the regulation requirement.
3. For LTE inter-band CA mode, Qualcomm Smart Transmit algorithm in WWAN adds directly the time-averaged RF exposure between two LTE bands. Smart Transmit algorithm controls the total RF exposure base on LTE inter band ULCA bands to not exceed FCC limit.

5G NR Output Power (Unit: dBm)

General Note:

1. 5G NR n2/n5/n7/n26/n66/n71/n38/n41/n77/n78 is SA mode.
2. 5G NR n2/n5/n7/n26/n66/n38/n41/n77/n78 is NSA mode.
3. For 5G NR test procedure was following step similar FCC KDB 941225 D05:
 - a. For DFT-OFDM and CP-OFDM output power measurement reduction, according to 38.101 maximum power reduction for power class2 and 3, the CP-OFDM mode will not higher than DFT-OFDM mode, therefore, similar FCC KDB 941225 D05 procedure for other modulation output power for each RB allocation configuration is > not ½ dB higher than the same configuration in DFT-s QPSK and the reported SAR for the DFT-s QPSK configuration is ≤ 1.45 W/kg; CP-OFDM testing is not required.
 - b. For DFT-OFDM output power measurement reduction, according to 38.101 maximum power reduction for power class2 and 3, for 16QAM/64QAM/256QAM and smaller bandwidth output power will spot check largest channel bandwidth worst RB configuration to ensure the 16QAM/64QAM/256QAM and smaller bandwidth output power will not ½ dB higher than the same configuration in the largest supported bandwidth.
 - c. SAR testing start with the largest channel bandwidth and measure SAR for QPSK with 1 RB allocation, using the RB offset and required test channel combination with the highest maximum output power for RB offsets at the upper edge, middle and lower edge of each required test channel
 - d. 50% RB allocation for QPSK SAR testing follows 1RB QPSK allocation procedure
 - e. QPSK with 100% RB allocation, SAR is not required when the highest maximum output power for 100 % RB allocation is less than the highest maximum output power in 50% and 1 RB allocations and the highest reported SAR for 1 RB and 50% RB allocation are ≤ 0.8 W/kg. Otherwise, SAR is measured for the highest output power channel; and if the reported SAR is > 1.45 W/kg, the remaining required test channels must also be tested
 - f. PI/2 BPSK/16QAM/64QAM/256QAM output powers according to 3GPP MPR will not ½ dB higher than the same configuration in QPSK, also reported SAR for the QPSK configuration is less than 1.45 W/kg, PI/2 BPSK /16QAM/64QAM/256QAM SAR testing are not required.
 - g. Smaller bandwidth output power for each RB allocation configuration for this device will not ½ dB higher than the same configuration in the largest supported bandwidth, and the reported SAR for the largest supported bandwidth is ≤ 1.45 W/kg, smaller bandwidth SAR testing is not required for this device
4. NSA and SA mode should perform SAR separately. For the maximum power of NSA mode is the same as SA total power level, so SA SAR can represent NSA mode SAR.
5. 5G NR NSA mode, the power level is the same as 5G NR SA mode, so 5G NR NSA mode and SA mode power table only show one time.
6. 5G NR supports CP-OFDM and DFT-s-OFDM modulation, for DFT-s-OFDM power is higher than CP-OFDM, so only show DFT-s-OFDM power table and chose DFT-s-OFDM to perform SAR testing.
7. For DFT-s-OFDM and CP-OFDM output power measurement reduction, according to 38.101 maximum power reduction for the CP-OFDM mode will not higher than DFT-s-OFDM mode, therefore, CP-OFDM measurement is unnecessary.
8. 5G NR n77/n78 supports HPUE, HPUE power and SAR testing performed separately.
9. 5G NR n77/n78 HPUE with higher power, For HPUE power is higher than power class 3 but with lower duty cycle, the maximum average power for class 2 and class 3 is almost the same, so we chose power class 3 full SAR testing and power class 2 verified the worst case of power class 3 SAR.
10. For 5G NR n77/n78 HPUE, 5G NR n77/n78 PC2 Maximum Duty Cycle is 50%, using FTM (Factory Test Mode) with 50% duty cycle is considered during SAR testing. For 5G NR other bands, using FTM to perform SAR with default 100% transmission.
11. For NR inter-band CA mode, Qualcomm Smart Transmit algorithm in WWAN adds directly the time-averaged RF exposure between two NR bands. Smart Transmit algorithm controls the total RF exposure base on NR inter band ULCA bands to not exceed FCC limit.
12. 5G NR n41 supports UL MIMO. Based on Qualcomm Smart Transmit algorithm, MIMO antennas located in different AGs do not require additional evaluation testing. Therefore, in this report, it is evaluated whether the sum of the groups of each antenna does not exceed FCC limit or spatial separation is applied, more detail please refers to section 17.

<3GPP 38.101 MPR for EN-DC>

Table 6.2.2-1 Maximum power reduction (MPR) for power class 3

Modulation		MPR (dB)		
		Edge RB allocations	Outer RB allocations	Inner RB allocations
DFT-s-OFDM	Pi/2 BPSK	$\leq 3.5^1$	$\leq 1.2^1$	$\leq 0.2^1$
		$\leq 0.5^2$	$\leq 0.5^2$	0 ²
	QPSK	≤ 1		0
	16 QAM	≤ 2		≤ 1
	64 QAM	≤ 2.5		
CP-OFDM	256 QAM	≤ 4.5		
	QPSK	≤ 3		≤ 1.5
	16 QAM	≤ 3		≤ 2
	64 QAM	≤ 3.5		
	256 QAM	≤ 6.5		

NOTE 1: Applicable for UE operating in TDD mode with Pi/2 BPSK modulation and UE indicates support for UE capability *powerBoosting-pi2BPSK* and if the IE *powerBoostPi2BPSK* is set to 1 and 40 % or less slots in radio frame are used for UL transmission for bands n40, n41, n77, n78 and n79. The reference power of 0 dB MPR is 26 dBm.

NOTE 2: Applicable for UE operating in FDD mode, or in TDD mode in bands other than n40, n41, n77, n78 and n79 with Pi/2 BPSK modulation and if the IE *powerBoostPi2BPSK* is set to 0 and if more than 40 % of slots in radio frame are used for UL transmission for bands n40, n41, n77, n78 and n79.

Table 6.2.2-2 Maximum power reduction (MPR) for power class 2

Modulation		MPR (dB)		
		Edge RB allocations	Outer RB allocations	Inner RB allocations
DFT-s-OFDM	Pi/2 BPSK	≤ 3.5	≤ 0.5	0
	QPSK	≤ 3.5	≤ 1	0
	16 QAM	≤ 3.5	≤ 2	≤ 1
	64 QAM	≤ 3.5	≤ 2.5	
	256 QAM	≤ 4.5		
CP-OFDM	QPSK	≤ 3.5	≤ 3	≤ 1.5
	16 QAM	≤ 3.5	≤ 3	≤ 2
	64 QAM	≤ 3.5		
	256 QAM	≤ 6.5		



<EN-DC combination>

ENDC	LTE TX	NR TX
DC_13A_n66A	Ant1	Ant2
DC_2A_n66A	Ant1/2	Ant1/2
DC_2A_n78A	Ant1/2	Ant4/5/7/8
DC_2A_n7A	Ant1/2	Ant1/2
DC_38A_n78A	Ant0/1/2/3	Ant4/5/7/8
DC_41A_n77A	Ant0/1/2/3	Ant4/5/7/8
DC_41A_n78A	Ant0/1/2/3	Ant4/5/7/8
DC_4A_n2A	Ant1/2	Ant1/2
DC_4A_n38A	Ant1/2	Ant1/2
DC_4A_n41A	Ant1/2	Ant1/2
DC_4A_n78A	Ant1/2	Ant4/5/7/8
DC_4A_n7A	Ant1/2	Ant1/2
DC_5A_n41A	Ant0/1	Ant0/1/2/3
DC_5A_n66A	Ant0/1	Ant1/2
DC_5A_n78A	Ant0/1	Ant4/5/7/8
DC_5A_n7A	Ant0/1	Ant1/2
DC_66A_n2A	Ant1/2	Ant1/2
DC_66A_n38A	Ant1/2	Ant1/2
DC_66A_n41A	Ant1/2	Ant1/2
DC_66A_n5A	Ant1/2	Ant0/1
DC_66A_n78A	Ant1/2	Ant4/5/7/8
DC_66A_n7A	Ant1/2	Ant1/2
DC_7A_n5A	Ant0/1/2/3	Ant0/1
DC_7A_n66A	Ant1/2	Ant1/2
DC_7A_n77A	Ant0/1/2/3	Ant4/5/7/8
DC_7A_n78A	Ant0/1/2/3	Ant4/5/7/8
DC_7A_n26A	Ant0/1/2/3	Ant0/1
DC_26A_n78A	Ant0/1	Ant4/5/7/8

Inter-Band CA Configuration:

NR Uplink CA	2CC Uplink Carrier Aggregation	
Inter-band	NR Tx	NR Tx
CA_n7A-n78A	Ant1/2	Ant4/5/7/8

NR UL MIMO Bands Configuration:

ULMIMO	Tx Ant	Tx Ant
5G NR n41	Ant 2+Ant 1	Ant 0+Ant 3

<WLAN Conducted Power>

General Note:

1. The maximum output power specified for production units are determined for all applicable 802.11 transmission modes in each standalone and aggregated frequency band. Maximum output power is measured for the highest maximum output power configuration(s) in each frequency band according to the default power measurement procedures. For "Not required", SAR Test reduction was applied from KDB 248227 guidance, Sec. 2.1, b), 1) when the same maximum power is specified for multiple transmission modes in a frequency band, the largest channel bandwidth, lowest order modulation, lowest data rate and lowest order 802.11a/g/n/ac mode is used for SAR measurement, on the highest measured output power channel in the initial test configuration. Additional output power measurements were not necessary.
2. Per KDB 248227 D01v02r02, SAR test reduction is determined according to 802.11 transmission mode configurations and certain exposure conditions with multiple test positions. In the 2.4 GHz band, separate SAR procedures are applied to DSSS and OFDM configurations to simplify DSSS test requirements. For OFDM, in both 2.4 and 5 GHz bands, an initial test configuration must be determined for each standalone and aggregated frequency band, according to the transmission mode configuration with the highest maximum output power specified for production units to perform SAR measurements. If the same highest maximum output power applies to different combinations of channel bandwidths, modulations and data rates, additional procedures are applied to determine which test configurations require SAR measurement. When applicable, an initial test position may be applied to reduce the number of SAR measurements required for next to the ear, UMPC mini-tablet or hotspot mode configurations with multiple test positions.
3. For 2.4 GHz 802.11b DSSS, either the initial test position procedure for multiple exposure test positions or the DSSS procedure for fixed exposure position is applied; these are mutually exclusive. For 2.4 GHz and 5 GHz OFDM configurations, the initial test configuration is applied to measure SAR using either the initial test position procedure for multiple exposure test position configurations or the initial test configuration procedures for fixed exposure test conditions. Based on the reported SAR of the measured configurations and maximum output power of the transmission mode configurations that are not included in the initial test configuration, the subsequent test configuration and initial test position procedures are applied to determine if SAR measurements are required for the remaining OFDM transmission configurations. In general, the number of test channels that require SAR measurement is minimized based on maximum output power measured for the test sample(s).
4. For OFDM transmission configurations in the 2.4 GHz and 5 GHz bands, When the same maximum power is specified for multiple transmission modes in a frequency band, the largest channel bandwidth, lowest order modulation, lowest data rate and lowest order 802.11a/g/n/ac mode is used for SAR measurement, on the highest measured output power channel for each frequency band.
5. DSSS and OFDM configurations are considered separately according to the required SAR procedures. SAR is measured in the initial test position using the 802.11 transmission mode configuration required by the DSSS procedure or initial test configuration and subsequent test configuration(s) according to the OFDM procedures.18 The initial test position procedure is described in the following:
 - a. When the reported SAR of the initial test position is ≤ 0.4 W/kg, further SAR measurement is not required for the other test positions in that exposure configuration and 802.11 transmission mode combinations within the frequency band or aggregated band.
 - b. When the reported SAR of the test position is > 0.4 W/kg, SAR is repeated for the 802.11 transmission mode configuration tested in the initial test position to measure the subsequent next closet/smallest test separation distance and maximum coupling test position on the highest maximum output power channel, until the report SAR is ≤ 0.8 W/kg or all required test position are tested.
 - c. For all positions/configurations, when the reported SAR is > 0.8 W/kg, SAR is measured for these test positions/configurations on the subsequent next highest measured output power channel(s) until the reported SAR is ≤ 1.2 W/kg or all required channels are tested.
6. 802.11 ax/be supports both full tone size mode and partial tone size mode, after verification on partial tone size mode that partial size tone mode power will not be higher than full tone size mode, therefore, full tone mode power was chosen to be measured in this report.
7. The 2.4GHz/5GHz/6GHz WLAN can transmit in MIMO antenna mode.



<2.4GHz Bluetooth>

General Note:

1. For 2.4GHz Bluetooth SAR testing was selected 1Mbps, due to its highest average power.
2. The Bluetooth duty cycle are 76.94% for ant 3 and 77.06% for ant 6 as following figure, for Bluetooth SAR scaling need further consideration and the theoretical duty cycle is 83.3%, therefore the actual duty cycle will be scaled up to 83.3% for Bluetooth reported SAR calculation

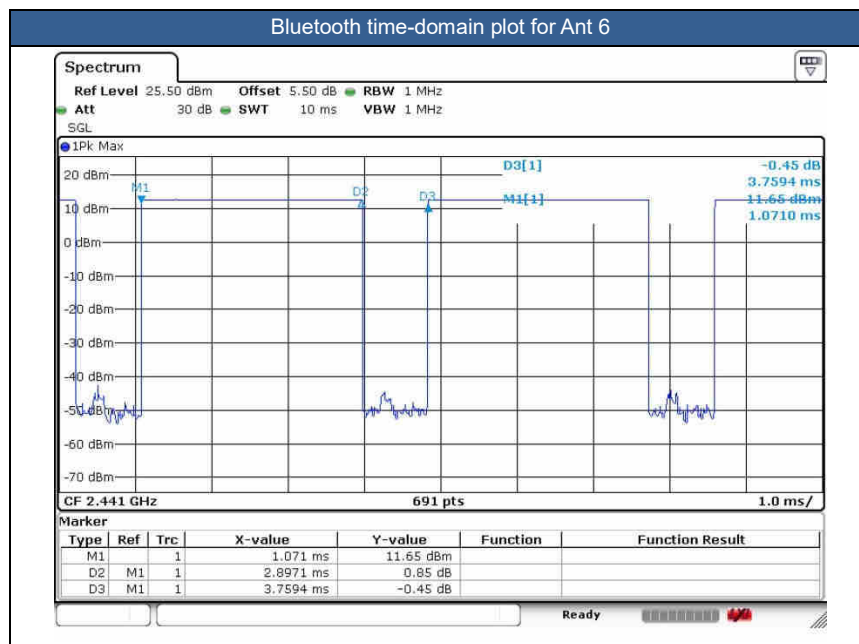
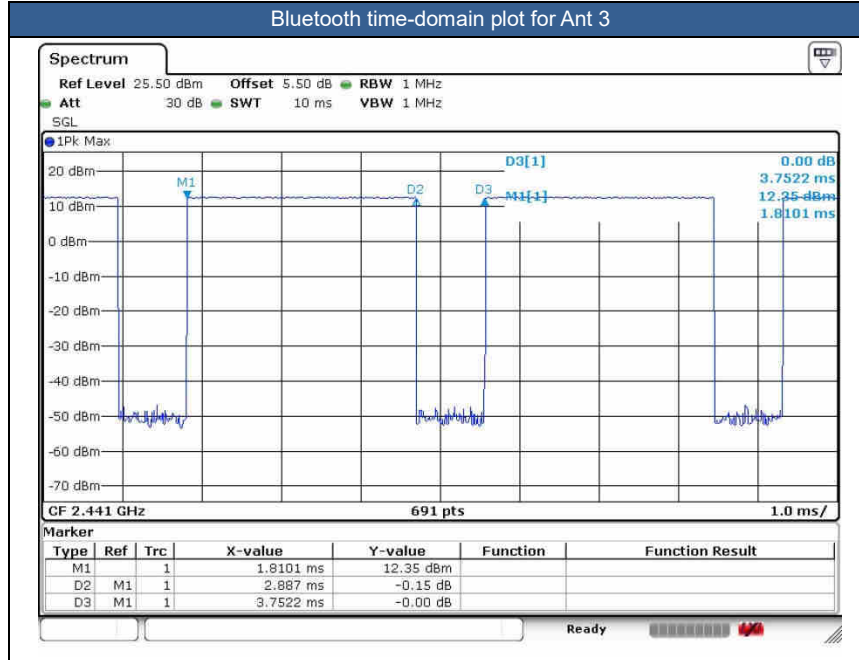



15. Antenna Location

The detailed antenna location information can refer to SAR Test Setup Photos.

16. SAR Test Results

General Note:

1. Per KDB 447498 D01v06, the reported SAR is the measured SAR value adjusted for maximum tune-up tolerance.
 - a. Tune-up scaling Factor = tune-up limit power (mW) / EUT RF power (mW), where tune-up limit is the maximum rated power among all production units.
 - b. For SAR testing of WLAN signal with non-100% duty cycle, the measured SAR is scaled-up by the duty cycle scaling factor which is equal to "1/(duty cycle)"
 - c. For SAR testing of Bluetooth signal with 83.3% theoretical duty cycle, the measured SAR is scaled-up by the duty cycle scaling factor which is equal to "1/(duty cycle) *83.3%".
 - d. For WWAN: Reported SAR(W/kg)= Measured SAR(W/kg)*Tune-up Scaling Factor
 - e. For BT/WLAN: Reported SAR(W/kg)= Measured SAR(W/kg)* Duty Cycle scaling factor * Tune-up scaling factor
 - f. For TDD LTE SAR measurement of power class 3, the duty cycle 1:1.59 (62.9 %) was used perform testing and considering the theoretical duty cycle of 63.3% for extended cyclic prefix in the uplink, and the theoretical duty cycle of 62.9% for normal cyclic prefix in uplink, a scaling factor of extended cyclic prefix 63.3%/62.9% = 1.006 is applied to scale-up the measured SAR result. The reported TDD LTE SAR (W/kg) = Measured SAR (W/kg)* Tune-up Scaling Factor* scaling factor for extended cyclic prefix.
 - g. For TDD LTE SAR measurement of power class 2, the duty cycle 1:2.33 (42.9 %) was used perform testing and considering the theoretical duty cycle of 43.3% for extended cyclic prefix in the uplink, and the theoretical duty cycle of 42.9% for normal cyclic prefix in uplink, a scaling factor of extended cyclic prefix 43.3%/42.9% = 1.009 is applied to scale-up the measured SAR result. The reported TDD LTE SAR (W/kg) = measured SAR (W/kg)* Tune-up Scaling Factor* scaling factor for extended cyclic prefix.
2. Per KDB 447498 D01v06, for each exposure position, testing of other required channels within the operating mode of a frequency band is not required when the *reported* 1-g or 10-g SAR for the mid-band or highest output power channel is:
 - ≤ 0.8 W/kg or 2.0 W/kg, for 1-g or 10-g respectively, when the transmission band is ≤ 100 MHz
 - ≤ 0.6 W/kg or 1.5 W/kg, for 1-g or 10-g respectively, when the transmission band is between 100 MHz and 200 MHz
 - ≤ 0.4 W/kg or 1.0 W/kg, for 1-g or 10-g respectively, when the transmission band is ≥ 200 MHz
3. Per KDB 865664 D01v01r04, for each frequency band, repeated SAR measurement is required when the measured SAR is ≥ 0.8W/kg. Per KDB 865664 D01v01r04, if the extremity repeated SAR is necessary, the same procedures should be adapted for measurements according to extremity and occupational exposure limits by applying a factor of 2.5 for extremity exposure and a factor of 5 for occupational exposure to the corresponding SAR thresholds.
4. The device implements the power management and proximity sensor /receiver detection/hotspot mode for SAR compliance at different exposure conditions (head, body-worn, hotspot, extremity) and the Qualcomm smart transmit will manage to ensure the power level not exceeding the associated power table. Details about the power management decision and sensor detection are provided in the operational description. And the device will invoke corresponding work scenarios power level base on frequency bands/antennas, which can refer to power table at appendix E.
5. Per KDB648474 D04v01r03, for smart phones with a display diagonal dimension > 15.0 cm or an overall diagonal dimension > 16.0 cm, when hotspot mode applies, 10-g extremity SAR is required only for the surfaces and edges with hotspot mode 1-g reported SAR > 1.2 W/kg, however, when power reduction applies to hotspot mode the measured SAR must be scaled to the maximum output power, including tolerance, allowed for phablet modes to compare with the 1.2 W/kg SAR test reduction threshold.
 - a. For this device SAR for WWAN/WLAN transmitter scaled to maximum output power mode for product specific 10g SAR is higher than 1.2W/kg of GSM1900, WCDMA Band II/IV/V, LTE Band 2/4/5/7/25/26/66/38/41/42, 5GNR n2/n7/n66/n38/ n41/n78/n77, WLAN2.4/5.2GHz, therefore product specific 10g SAR is necessary.
 - b. WLAN 5.3/5.5GHz tested the product specific 10g SAR since it has no hotspot mode.
 - c. When 10-g product specific 10g SAR is considered, SAR thresholds is specified in the procedures for SAR test reduction and exclusion should be multiplied by 2.5.
6. Although the headset SAR is greater than 0.8 W/kg, the headset SAR verified the worst of the non-headset SAR and less than non-headset SAR, so there is no need to be tested other channels.
7. According to Nov. 2017 TCB workshop, when the reported 1gSAR for UL CA configuration is <1.2 W/kg, UL CA 1gSAR is not required for all required test channels (PCC based).
8. LTE B2/4/7/66/38/41 at ant1 support different PAs and LTE bands support Other PA only under ENDC & UL CA. whether it is the maximum power of Main PA is higher than and very close to the other PA, for RF exposure, after verification all PAs in a same position, so the worst-case PA was chosen to perform full SAR testing to ensure the



RF exposure is compliance and other PAs verified the worst case.

GSM Note:

1. Per KDB 941225 D01v03r01, for SAR test reduction for GSM / GPRS / EDGE modes is determined by the source-based time-averaged output power including tune-up tolerance. The mode with highest specified time-averaged output power should be tested for SAR compliance in the applicable exposure conditions. For modes with the same specified maximum output power and tolerance, the higher number time-slot configuration should be tested.
2. Other configurations of GSM / GPRS / EDGE are considered as secondary modes. The 3G SAR test reduction procedure is applied, when the maximum output power and tune-up tolerance specified for production units in a secondary mode is \leq ¼ dB higher than the primary mode, SAR measurement is not required for the secondary mode.

WCDMA Note:

1. Per KDB 941225 D01v03r01, for SAR testing is measured using a 12.2 kbps RMC with TPC bits configured to all "1's".
2. Per KDB 941225 D01v03r01, RMC 12.2kbps setting is used to evaluate SAR. The maximum output power and tune-up tolerance specified for production units in HSDPA / HSUPA / DC-HSDPA is \leq ¼ dB higher than RMC 12.2Kbps or when the highest reported SAR of the RMC12.2Kbps is scaled by the ratio of specified maximum output power and tune-up tolerance of HSDPA / HSUPA / DC-HSDPA to RMC12.2Kbps and the adjusted SAR is \leq 1.2 W/kg, SAR measurement is not required for HSDPA / HSUPA / DC-HSDPA, and according to the following RF output power, the output power results of the secondary modes (HSDPA / HSUPA / DC-HSDPA) are less than ¼ dB higher than the primary modes; therefore, SAR measurement is not required for HSDPA / HSUPA / DC-HSDPA.

LTE Note:

1. Per KDB 941225 D05v02r05, start with the largest channel bandwidth and measure SAR for QPSK with 1 RB allocation, using the RB offset and required test channel combination with the highest maximum output power for RB offsets at the upper edge, middle and lower edge of each required test channel.
2. Per KDB 941225 D05v02r05, 50% RB allocation for QPSK SAR testing follows 1RB QPSK allocation procedure.
3. Per KDB 941225 D05v02r05, for QPSK with 100% RB allocation, SAR is not required when the highest maximum output power for 100 % RB allocation is less than the highest maximum output power in 50% and 1 RB allocations and the highest reported SAR for 1 RB and 50% RB allocation are \leq 0.8 W/kg. Otherwise, SAR is measured for the highest output power channel; and if the reported SAR is $>$ 1.45 W/kg, the remaining required test channels must also be tested.
4. Per KDB 941225 D05v02r05, 16QAM/64QAM/256QAM output power for each RB allocation configuration is $>$ not ½ dB higher than the same configuration in QPSK and the reported SAR for the QPSK configuration is \leq 1.45 W/kg; Per KDB 941225 D05v02r05, 16QAM/64QAM/256QAM SAR testing is not required.
5. Per KDB 941225 D05v02r05, smaller bandwidth output power for each RB allocation configuration is $>$ not ½ dB higher than the same configuration in the largest supported bandwidth, and the reported SAR for the largest supported bandwidth is \leq 1.45 W/kg; Per KDB 941225 D05v02r05, smaller bandwidth SAR testing is not required.
6. For LTE B4 / B5 / B12 / B17 / B26 / B38 the maximum bandwidth does not support three non-overlapping channels, per KDB 941225 D05v02r05, when a device supports overlapping channel assignment in a channel bandwidth configuration, the middle channel of the group of overlapping channels should be selected for testing.
7. LTE B2 / B4 / B5 / B17 / B38 SAR test was covered by B25 / B66 / B26 / B12 / B41; according to April 2015 TCB workshop, SAR test for overlapping LTE bands can be reduced if
 - a. the maximum output power, including tolerance, for the smaller band is \leq the larger band to qualify for the SAR test exclusion
 - b. the channel bandwidth and other operating parameters for the smaller band are fully supported by the larger band

5G NR Note:

1. For 5G NR test procedure was following step similar FCC KDB 941225 D05:
 - a. SAR testing start with the largest channel bandwidth and measure SAR for QPSK with 1 RB allocation, using the RB offset and required test channel combination with the highest maximum output power for RB offsets at the upper edge, middle and lower edge of each required test channel.
 - b. 50% RB allocation for QPSK SAR testing follows 1RB QPSK allocation procedure
 - c. QPSK with 100% RB allocation, SAR is not required when the highest maximum output power for 100 % RB allocation is less than the highest maximum output power in 50% and 1 RB allocations and the highest reported SAR for 1 RB and 50% RB allocation are ≤ 0.8 W/kg. Otherwise, SAR is measured for the highest output power channel; and if the reported SAR is > 1.45 W/kg, the remaining required test channels must also be tested.
 - d. PI/2 BPSK/16QAM/64QAM/256QAM output powers according to 3GPP MPR will not $\frac{1}{2}$ dB higher than the same configuration in QPSK, also reported SAR for the QPSK configuration is less than 1.45 W/kg, PI/2 BPSK /16QAM/64QAM/256QAM SAR testing are not required.
 - e. Smaller bandwidth output power for each RB allocation configuration for this device will not $\frac{1}{2}$ dB higher than the same configuration in the largest supported bandwidth, and the reported SAR for the largest supported bandwidth is ≤ 1.45 W/kg, smaller bandwidth SAR testing is not required for this device
 - f. For 5G FR1 n5 /n7/n26/n66/n38/n41/n77 the maximum bandwidth does not support three non-overlapping channels, when a device supports overlapping channel assignment in a channel bandwidth configuration, the middle channel of the group of overlapping channels should be selected for testing.

WLAN/Bluetooth Note:

1. Per KDB 248227 D01v02r02, for 2.4GHz 802.11g/n SAR testing is not required when the highest reported SAR for DSSS is adjusted by the ratio of OFDM to DSSS specified maximum output power and the adjusted SAR is ≤ 1.2 W/kg.
2. Per KDB 248227 D01v02r02, U-NII-1 SAR testing is not required when the U-NII-2A band highest reported SAR for a test configuration is ≤ 1.2 W/kg, SAR is not required for U-NII-1 band.
3. When the reported SAR of the test position is > 0.4 W/kg, SAR is repeated for the 802.11 transmission mode configuration tested in the initial test position to measure the subsequent next closest/smallest test separation distance and maximum coupling test position on the highest maximum output power channel, until the report SAR is ≤ 0.8 W/kg or all required test position are tested.
4. For all positions / configurations, when the reported SAR is > 0.8 W/kg, SAR is measured for these test positions / configurations on the subsequent next highest measured output power channel(s) until the reported SAR is ≤ 1.2 W/kg or all required channels are tested.
5. During SAR testing the WLAN transmission was verified using a spectrum analyzer.
6. For determination of the scaling factor for report SAR of MIMO mode, if the hot spots are separated the scaling factors are individually determined from each transmit chain. Further simplification chose the worse SAR value and the worst scaling factor from each transmit chain perform reported SAR calculation conservatively. If the hot spots are not spatially separated, the scaling factor is determined from the worst number of each transmit chain.

DSI status description:

The device has the following DSI state which used at different exposure condition.

This WWAN and WLAN/BT bands enabled with Qualcomm Smart Transmit feature which located at chapter 5. The default power is Pmax power, When Plimit power higher than Pmax power, the output power will be limited at Pmax, and so the SAR will use Pmax power to do the testing.

Exposure Condition	DSI	Trigger Conditions
Head SAR	DSI 2	Receiver on
Body worn SAR	DSI 3	Sensor On
Hotspot SAR	DSI 7	Hotspot On
Extremity (Handheld) SAR	DSI 6	Sensor On
Sensor Off SAR	DSI 4	Sensor Off



FCC SAR Test Report

Report No. : FA420701

Table with 20 columns: FR1 n71, 20M, QPSK, 50, 28, DFT-SCS-15KHz, Left Cheek, 0mm, Ant 1, DSI 2, 136100, 680.5, 1, 22.49, 24.00, 1.416, -, -, 0.13, 0.130, 0.184. Rows include GSM850, WCDMA V, and LTE Band 26 tests.



FCC SAR Test Report

Report No. : FA420701

Table with columns for frequency bands (LTE Band 25, FR1 n2, LTE Band 7), power (20M), modulation (QPSK), and SAR values. Includes a section for 2600MHz bands.



FCC SAR Test Report

Report No. : FA420701

Table with columns for Band, Power, Modulation, Frequency, Duty Cycle, Position, Antenna, DSI, Power Density, and SAR values. Includes rows for LTE Band 42, FR1 n77, and FR1 n77 PC2.



16.2 Hotspot SAR

Table with 20 columns: Plot No., Band, BW (MHz), Modulation, RB Size, RB offset, Mode, Test Position, Gap (mm), Antenna, Power State, Ch., Freq. (MHz), Sample, Average Power (dBm), Tune-Up Limit (dBm), Tune-up Scaling Factor, Duty Cycle %, Duty Cycle Scaling Factor, Power Drift (dB), Measured 1g SAR (W/kg), Reported 1g SAR (W/kg). Includes rows for LTE Bands 12, 13 and FR1 n71.



Table with columns for frequency, power, modulation, and SAR values for various standards like GSM1900, WCDMA II, and LTE Band 25. The table contains 60 rows of test data.



FCC SAR Test Report

Report No. : FA420701

Table with columns for Band, Modulation, Power, Frequency, Distance, Side, Antenna, DSI, Power Density, and SAR values. Includes rows for LTE Band 25 and FR1 n2, with a highlighted value of 1.285 in the 38th row.



Table with 20 columns: LTE Band, Modulation, Power, Duty Cycle, Frequency, Direction, Distance, Antenna, Device, Power Density, etc. Row 40 is highlighted with a yellow background.



Table with columns for Band, Modulation, Power, Frequency, Direction, Antenna, DSI, and various SAR metrics (E1, E2, E3, E4, E5, E6, E7, E8, E9, E10).



FCC SAR Test Report

Report No. : FA420701

Table with 20 columns: Band, Modulation, Power, etc. Row 41 is highlighted with a value of 1.315.



16.3 Body Worn Accessory SAR

Table with columns: Plot No., Band, BW (MHz), Modulation, RB Size, RB offset, Mode, Test Position, Gap (mm), Antenna, Headset, Power State, Ch., Freq. (MHz), Sample, Average Power (dBm), Tune-Up Limit (dBm), Tune-up Scaling Factor, Duty Cycle %, Duty Cycle Scaling Factor, Power Drift (dB), Measured 1g SAR (W/kg), Reported 1g SAR (W/kg). Rows include 750MHz, 835MHz, and 15MHz bands.



FCC SAR Test Report

Report No. : FA420701

Table with columns for LTE Band, Modulation, Power, etc. Includes rows for LTE Band 26, FR1 n26, WCDMA IV, and LTE Band 66. Some cells are highlighted in yellow (e.g., 1.292, 0.900, 1.272).



FCC SAR Test Report

Report No. : FA420701

Table with 23 columns: Band, Modulation, Power, etc. Row 64 is highlighted with a yellow background and contains the value 1.316.



FCC SAR Test Report

Report No. : FA420701

Table with columns for Band, Power, Modulation, Frequency, Position, Distance, Antenna, Headset, DSI, Frequency 1, Frequency 2, Power 1, Power 2, SAR 1, SAR 2, SAR 3, SAR 4, SAR 5, SAR 6, SAR 7, SAR 8, SAR 9, SAR 10. Row 65 is highlighted in yellow.



FCC SAR Test Report

Report No. : FA420701

Table with columns for test parameters (FR1 n41, 100M, QPSK, 270, 0, DFT-SCS-30KHz, Front, 5mm, Ant 3, etc.) and SAR values. Includes a sub-section for 3500MHz with multiple rows for LTE Band 42 and FR1 n77.

