



Partial FCC RF Test Report

APPLICANT : Motorola Mobility LLC
EQUIPMENT : Mobile Cellular Phone
BRAND NAME : Motorola
MODEL NAME : XT2427-2
FCC ID : IHDT56AN9
STANDARD : 47 CFR Part 2, 27(O)
CLASSIFICATION : PCS Licensed Transmitter Held to Ear (PCE)
TEST DATE(S) : Apr. 16, 2024 ~ May 21, 2024

We, Sporton International Inc. (ShenZhen), would like to declare that the tested sample has been evaluated in accordance with the procedures given in ANSI C63.26-2015 and shown compliance with the applicable technical standards.

The test results in this report apply exclusively to the tested model / sample. Without written approval of Sporton International Inc. (ShenZhen), the test report shall not be reproduced except in full.

Jason Jia

Approved by: Jason Jia



Sporton International Inc. (ShenZhen)

1/F, 2/F, Bldg 5, Shiling Industrial Zone, Xinwei Village, Xili, Nanshan, Shenzhen, 518055

People's Republic of China



TABLE OF CONTENTS

REVISION HISTORY...3
SUMMARY OF TEST RESULT...4
1 GENERAL DESCRIPTION...5
1.1 Applicant...5
1.2 Manufacturer...5
1.3 Product Feature of Equipment Under Test...5
1.4 Product Specification of Equipment Under Test...5
1.5 Modification of EUT...6
1.6 Testing Location...6
1.7 Test Software...6
1.8 Applicable Standards...6
1.9 Specification of Accessory...7
2 TEST CONFIGURATION OF EQUIPMENT UNDER TEST...8
2.1 Test Mode...8
2.2 Connection Diagram of Test System...9
2.3 Support Unit used in test configuration and system...9
2.4 Frequency List of Low/Middle/High Channels...10
3 CONDUCTED TEST ITEMS...12
3.1 Measuring Instruments...12
3.2 Test Setup...12
3.3 Test Result of Conducted Test...12
3.4 Radiated Spurious Emission...13
4 LIST OF MEASURING EQUIPMENT...14
5 MEASUREMENT UNCERTAINTY...15
APPENDIX A. TEST RESULTS OF RADIATED TEST
APPENDIX B. TEST SETUP PHOTOGRAPHS



REVISION HISTORY

REPORT NO.	VERSION	DESCRIPTION	ISSUED DATE
FG432901-01	Rev. 01	Initial issue of report	May 09, 2024
FG432901-01	Rev. 02	Updated accessories in section 1.9.	May 17, 2024
FG432901-01	Rev. 03	Added test data for 5G NR n78	May 22, 2024



SUMMARY OF TEST RESULT

Report Section	FCC Rule	Description	Limit	Result	Remark
3.4	§2.1053 §27.53(l)(2)	Radiated Spurious Emission (5G NR n77, n78)	$< 43+10\log_{10}(P[\text{Watts}])$	PASS	Under limit 28.38 dB at 7765.50 MHz

Note: For Power/ERP/EIRP/conducted test items of 5G NR Bands, test report will be issued separately.

Conformity Assessment Condition:
1. The test results (PASS/FAIL) with all measurement uncertainty excluded are presented against the regulation limits or in accordance with the requirements stipulated by the applicant/manufacturer who shall bear all the risks of non-compliance that may potentially occur if measurement uncertainty is taken into account.
2. The measurement uncertainty please refer to each test result in the section "Measurement Uncertainty"
Disclaimer:
The product specifications of the EUT presented in the test report that may affect the test assessments are declared by the manufacturer who shall take full responsibility for the authenticity.



1 General Description

1.1 Applicant

Motorola Mobility LLC
222 W,Merchandise Mart Plaza, Chicago IL 60654 USA

1.2 Manufacturer

Motorola Mobility LLC
222 W,Merchandise Mart Plaza, Chicago IL 60654 USA

1.3 Product Feature of Equipment Under Test

Product Feature	
Equipment	Mobile Cellular Phone
Brand Name	Motorola
Model Name	XT2427-2
FCC ID	IHDT56AN9
IMEI Code	Radiation : 356446900012993/356446900013009
HW Version	DVT2
SW Version	U3UO34.31
EUT Stage	Identical Prototype

1.4 Product Specification of Equipment Under Test

Standards-related Product Specification	
Tx Frequency	5G NR n77: 3700 MHz ~ 3980 MHz 5G NR n78: 3700 MHz ~ 3800 MHz
Rx Frequency	5G NR n77: 3700 MHz ~ 3980 MHz 5G NR n78: 3700 MHz ~ 3800 MHz
Bandwidth	n77/n78: 20MHz / 30MHz / 40MHz / 50MHz / 60MHz / 70MHz / 80MHz / 90MHz / 100MHz
SCS	30kHz
Type of Modulation	CP-OFDM: QPSK / 16QAM / 64QAM / 256QAM DFT-s-OFDM: PI/2 BPSK / QPSK / 16QAM / 64QAM / 256QAM

Remark:

1. The EN-DC mode combination could be referred to the product spec.
2. 5G NR n77/78 support SA/NSA mode.



1.5 Modification of EUT

No modifications are made to the EUT during all test items.

1.6 Testing Location

Sporton International Inc. (ShenZhen) is accredited to ISO/IEC 17025:2017 by American Association for Laboratory Accreditation with Certificate Number 5145.01.

Test Firm	Sporton International Inc. (ShenZhen)		
Test Site Location	101, 1st Floor, Block B, Building 1, No. 2, Tengfeng 4th Road, Fenghuang Community, Fuyong Street, Baoan District, Shenzhen City, Guangdong Province 518103 People's Republic of China TEL: +86-755-86066985		
Test Site No.	Sporton Site No.	FCC Designation No.	FCC Test Firm Registration No.
	03CH01-SZ	CN1256	421272

1.7 Test Software

Item	Site	Manufacture	Name	Version
1.	03CH01-SZ	AUDIX	E3	6.2009-8-24

1.8 Applicable Standards

According to the specifications of the manufacturer, the EUT must comply with the requirements of the following standards:

- 47 CFR Part 2, 27(O)
- ANSI C63.26-2015
- FCC KDB 971168 D01 Power Meas License Digital Systems v03r01
- FCC KDB 412172 D01 Determining ERP and EIRP v01r01

Remark:

All test items were verified and recorded according to the standards and without any deviation during the test.



1.9 Specification of Accessory

Specification of Accessory				
AC Adapter 1(US)	Brand Name	Motorola (Chenyang)	Model Name	MC-331
AC Adapter 1(EU)	Brand Name	Motorola (Chenyang)	Model Name	MC-332
AC Adapter 1(AU)	Brand Name	Motorola (Chenyang)	Model Name	MC-335
AC Adapter 1(AR)	Brand Name	Motorola (Chenyang)	Model Name	MC-336
AC Adapter 1(BR)	Brand Name	Motorola (Chenyang)	Model Name	MC-337
AC Adapter 2(US)	Brand Name	Motorola (AOHAI)	Model Name	MC-331
AC Adapter 2(EU)	Brand Name	Motorola (AOHAI)	Model Name	MC-332
AC Adapter 2(UK)	Brand Name	Motorola (AOHAI)	Model Name	MC-333
AC Adapter 3(CHILE)	Brand Name	Motorola (Salcomp)	Model Name	MC-339
AC Adapter 3(KR)	Brand Name	Motorola (Salcomp)	Model Name	MC-330
Battery 1	Brand Name	Motorola (SCUD)	Model Name	QE50
Battery 2	Brand Name	Motorola (COSMX)	Model Name	QE50
USB Cable 1	Brand Name	Motorola (hexin)	Model Name	S928E21807
USB Cable 2	Brand Name	Motorola (chuantuo)	Model Name	S928E21806
Earphone	Brand Name	Motorola (Lyand)	Model Name	MI181C



2 Test Configuration of Equipment Under Test

2.1 Test Mode

Antenna port conducted and radiated test items are performed according to KDB 971168 D01 Power Meas License Digital Systems v03r01 with maximum output power.

For radiated measurement, pre-scanned in three orthogonal panels, X, Y, Z. The worst cases (X/Z plane) were recorded in this report.

The device is investigated from 30MHz to 10 times of fundamental signal for radiated spurious emission test under different RB size/offset and modulations in exploratory test. Subsequently, only the worst case emissions are reported.

Orthogonal Planes of EUT	X Plane	Y Plane	Z Plane
			

Test Items	5G NR	Bandwidth (MHz)											Modulation				RB #		Test Channel						
		-	-	-	20	30	40	50	60	70	80	90	100	PI/2 BPSK	QPSK	16QAM	64QAM	256QAM	1	Full	L	M	H		
Radiated Spurious Emission	n77	Worst Case																						v	
	n78	Worst Case																						v	
Note	1. The mark "v" means that this configuration is chosen for testing 2. The mark "-" means that this bandwidth is not supported. 3. The device is investigated from 30MHz to 10 times of fundamental signal for radiated spurious emission test under different RB size/offset and modulations in exploratory test. Subsequently, only the worst case emissions are reported.																								

2.2 Connection Diagram of Test System

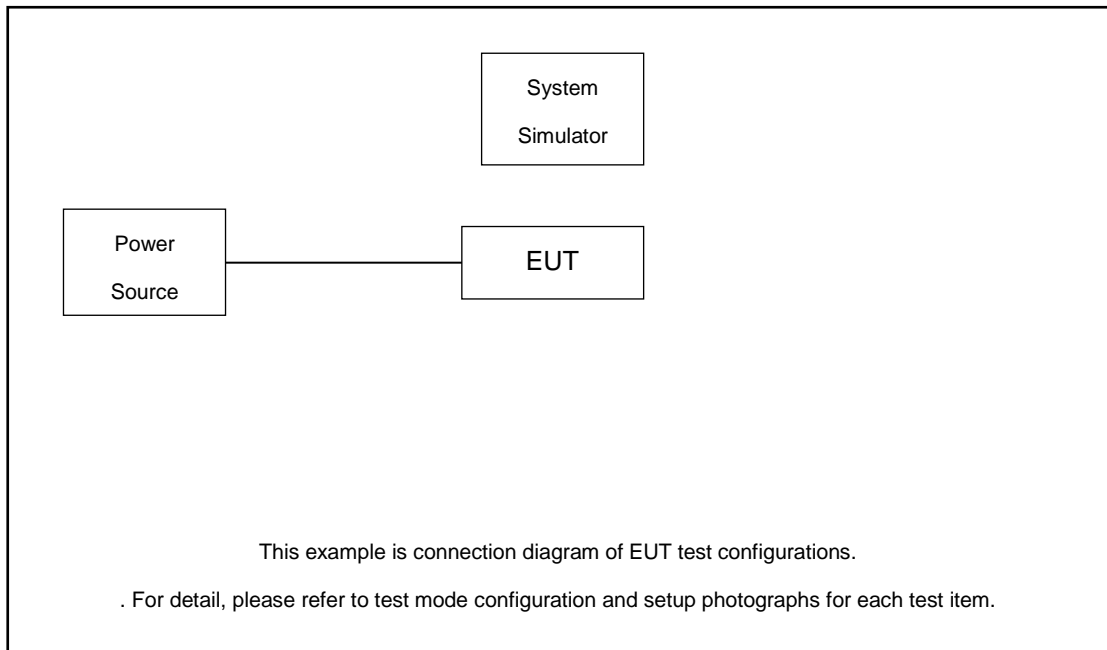

The EUT has been configuration operated in a manner tended to maximize its emission characteristics in a typical application.

2.3 Support Unit used in test configuration and system

Item	Equipment	Trade Name	Model No.	FCC ID	Data Cable	Power Cord
1.	DC Power Supply	GW	GPS-3030D	N/A	N/A	Unshielded, 1.8 m
2.	LTE Base Station	Anritsu	MT8821C	N/A	N/A	Unshielded, 1.8 m
3.	NR Base Station	Anritsu	MT8000A	N/A	N/A	Unshielded, 1.8 m



2.4 Frequency List of Low/Middle/High Channels

5G n77 Channel and Frequency List				
BW [MHz]	Channel/Frequency(MHz)	Lowest	Middle	Highest
100	Channel	650000	656000	662000
	Frequency	3750	3840	3930
90	Channel	649668	656000	662332
	Frequency	3745.02	3840	3934.98
80	Channel	649334	656000	662666
	Frequency	3740.01	3840	3939.99
70	Channel	649000	656000	663000
	Frequency	3735	3840	3945
60	Channel	648668	656000	663332
	Frequency	3730.02	3840	3949.98
50	Channel	648334	656000	663666
	Frequency	3725.01	3840	3954.99
40	Channel	648000	656000	664000
	Frequency	3720	3840	3960
30	Channel	647668	656000	664332
	Frequency	3715.02	3840	3964.98
20	Channel	647334	656000	664666
	Frequency	3710.01	3840	3969.99



5G n78 Channel and Frequency List				
BW [MHz]	Channel/Frequency(MHz)	Lowest	Middle	Highest
100	Channel	650000		
	Frequency	3750		
90	Channel	649668	650000	650332
	Frequency	3745.02	3750	3754.98
80	Channel	649334	650000	650666
	Frequency	3740.01	3750	3759.99
70	Channel	649000	650000	651000
	Frequency	3735	3750	3765
60	Channel	648668	650000	651332
	Frequency	3730.02	3750	3769.98
50	Channel	648334	650000	651666
	Frequency	3725.01	3750	3774.99
40	Channel	648000	650000	652000
	Frequency	3720	3750	3780
30	Channel	647668	650000	652332
	Frequency	3715.02	3750	3784.98
20	Channel	647334	650000	652666
	Frequency	3710.01	3750	3789.99

3 Conducted Test Items

3.1 Measuring Instruments

See list of measuring instruments of this test report.

3.2 Test Setup

3.2.1 Conducted Output Power



3.2.2 Peak-to-Average Ratio, Occupied Bandwidth, Conducted Band-Edge and Conducted Spurious Emission



3.2.3 Frequency Stability

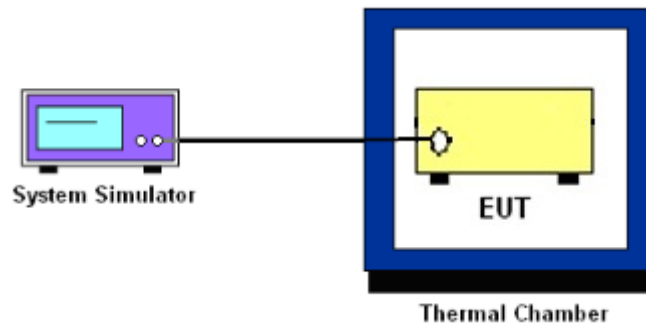

3.3 Test Result of Conducted Test

Please refer to Appendix A.



3.4 Radiated Spurious Emission

3.4.1 Description of Radiated Spurious Emission

The radiated spurious emission was measured by substitution method according to ANSI C63.26. The power of any emission outside of the authorized operating frequency ranges must be attenuated below the transmitter power (P) by a factor of at least $43 + 10 \log (P)$ dB.

The spectrum is scanned from 30 MHz up to a frequency including its 10th harmonic.

3.4.2 Test Procedures

1. The testing follows ANSI C63.26 Section 5.5
2. The EUT was placed on a turntable with 0.8 meter height for frequency below 1GHz and 1.5 meter height for frequency above 1GHz respectively above ground.
3. The EUT was set 3 meters from the receiving antenna mounted on the antenna tower.
4. The table was rotated 360 degrees to determine the position of the highest spurious emission.
5. The height of the receiving antenna is varied between 1m to 4m to search the maximum spurious emission for both horizontal and vertical polarizations.
6. During the measurement, the system simulator parameters were set to force the EUT transmitting at maximum output power.
7. Make the measurement with the spectrum analyzer's RBW = 1MHz, VBW = 3MHz, taking the record of maximum spurious emission.
8. A horn antenna was substituted in place of the EUT and was driven by a signal generator.
9. Tune the output power of signal generator to the same emission level with EUT maximum spurious emission.
10. $EIRP \text{ (dBm)} = S.G. \text{ Power} - Tx \text{ Cable Loss} + Tx \text{ Antenna Gain}$
11. $ERP \text{ (dBm)} = EIRP - 2.15$
12. The RF fundamental frequency should be excluded against the limit line in the operating frequency band.

The limit line is derived from $43 + 10\log(P)$ dB below the transmitter power P(Watts)
= $P(W) - [43 + 10\log(P)] \text{ (dB)}$
= $[30 + 10\log(P)] \text{ (dBm)} - [43 + 10\log(P)] \text{ (dB)}$
= -13dBm.



4 List of Measuring Equipment

Instrument	Manufacturer	Model No.	Serial No.	Characteristics	Calibration Date	Test Date	Due Date	Remark
EMI Test Receiver&SA	Agilent	N9038A	MY52260185	20Hz~26.5GHz	Dec. 27, 2023	Apr. 16, 2024~ May 21, 2024	Dec. 26, 2024	Radiation (03CH01-SZ)
Loop Antenna	R&S	HFH2-Z2	100354	9kHz~30MHz	Jul. 28, 2022	Apr. 16, 2024~ May 21, 2024	Jul. 27, 2024	Radiation (03CH01-SZ)
HF Amplifier	KEYSIGHT	83017A	MY53270105	0.5GHz~26.5Ghz	Oct. 18, 2023	Apr. 16, 2024~ May 21, 2024	Oct. 17, 2024	Radiation (03CH01-SZ)
Bilog Antenna	TeseQ	CBL6112D	35407	30MHz-2GHz	Oct. 24, 2023	Apr. 16, 2024~ May 21, 2024	Oct. 23, 2025	Radiation (03CH01-SZ)
Double Ridge Horn Antenna	ETS-Lindgren	3117	00119436	1GHz~18GHz	Jul. 08, 2023	Apr. 16, 2024~ May 21, 2024	Jul. 07, 2024	Radiation (03CH01-SZ)
SHF-EHF Horn	com-power	AH-840	101071	18Ghz-40GHz	Apr. 09, 2024	Apr. 16, 2024~ May 21, 2024	Apr. 08, 2025	Radiation (03CH01-SZ)
LF Amplifier	Burgeon	BPA-530	102209	0.01~3000Mhz	Apr. 09, 2024	Apr. 16, 2024~ May 21, 2024	Apr. 08, 2025	Radiation (03CH01-SZ)
HF Amplifier	MITEQ	AMF-7D-00 101800-30-1 0P-R	1943528	1GHz~18GHz	Oct. 18, 2023	Apr. 16, 2024~ May 21, 2024	Oct. 17, 2024	Radiation (03CH01-SZ)
HF Amplifier	MITEQ	TTA1840-35 -HG	1871923	18GHz~40GHz	Jul. 07, 2023	Apr. 16, 2024~ May 21, 2024	Jul. 06, 2024	Radiation (03CH01-SZ)
AC Power Source	Chroma	61601	616010001985	N/A	Oct. 18, 2023	Apr. 16, 2024~ May 21, 2024	Oct. 17, 2024	Radiation (03CH01-SZ)
Turn Table	EM	EM1000	N/A	0~360 degree	NCR	Apr. 16, 2024~ May 21, 2024	NCR	Radiation (03CH01-SZ)
Antenna Mast	EM	EM1000	N/A	1 m~4 m	NCR	Apr. 16, 2024~ May 21, 2024	NCR	Radiation (03CH01-SZ)

NCR: No Calibration Required



5 Measurement Uncertainty

The measurement uncertainties shown below were calculated in accordance with the requirements of ANSI 63.26-2015. All the measurement uncertainty value were shown with a coverage K=2 to indicate 95% level of confidence. The measurement data show herein meets or exceeds the CISPR measurement uncertainty values specified in CISPR 16-4-2 and can be compared directly to specified limit to determine compliance.

Uncertainty of Radiated Emission Measurement (30 MHz ~ 1000 MHz)

Measuring Uncertainty for a Level of Confidence of 95% (U = 2Uc(y))	2.48 dB
---	---------

Uncertainty of Radiated Emission Measurement (1 GHz ~ 18 GHz)

Measuring Uncertainty for a Level of Confidence of 95% (U = 2Uc(y))	3.53 dB
---	---------

Uncertainty of Radiated Emission Measurement (18 GHz ~ 40 GHz)

Measuring Uncertainty for a Level of Confidence of 95% (U = 2Uc(y))	4.02 dB
---	---------

----- THE END -----



Appendix A. Test Results of Radiated Test

Radiated Spurious Emission

Test Engineer :	Shiwei Wen	Temperature :	22~25°C
		Relative Humidity :	48~52%

Note: Pre-scanned harmonic for the different antenna combinations, we choose the worst antenna mode to perform final test.

n77 SA / NR 100MHz / QPSK(ANT7)									
Channel	Frequency (MHz)	EIRP (dBm)	Limit (dBm)	Over Limit (dB)	SPA Reading (dBm)	S.G. Power (dBm)	TX Cable loss (dB)	TX Antenna Gain (dBi)	Polarization (H/V)
Middle	7582.36	-57.63	-13	-44.63	-65.94	-60.93	8.30	11.60	H
	11373.54	-55.03	-13	-42.03	-69.37	-56.55	10.48	12.00	H
	15164.72	-51.60	-13	-38.60	-69.69	-53.30	11.80	13.50	H
	7582.36	-57.48	-13	-44.48	-65.79	-60.78	8.30	11.60	V
	11373.54	-47.36	-13	-34.36	-65.78	-48.88	10.48	12.00	V
	15164.72	-51.95	-13	-38.95	-70.03	-53.65	11.80	13.50	V

Remark: Spurious emissions within 30-1000MHz were found more than 20dB below limit line.

EN-DC_41A_n77A / LTE 10MHz + NR 100MHz / QPSK (ANT1+3)									
Channel	Frequency (MHz)	EIRP (dBm)	Limit (dBm)	Over Limit (dB)	SPA Reading (dBm)	S.G. Power (dBm)	TX Cable loss (dB)	TX Antenna Gain (dBi)	Polarization (H/V)
NR n77 Middle	7582.36	-57.46	-13	-44.46	-65.77	-60.76	8.30	11.60	H
	11373.54	-54.77	-13	-41.77	-69.11	-56.29	10.48	12.00	H
	15164.72	-51.85	-13	-38.85	-69.94	-53.55	11.80	13.50	H
	7582.36	-57.46	-13	-44.46	-65.77	-60.76	8.30	11.60	V
	11373.54	-50.38	-13	-37.38	-68.8	-51.90	10.48	12.00	V
	15164.72	-51.60	-13	-38.60	-69.68	-53.30	11.80	13.50	V
LTE Band41 Middle	5177.00	-60.60	-25	-35.60	-65.64	-66.16	7.14	12.70	H
	7765.50	-57.28	-25	-32.28	-65.12	-60.58	8.30	11.60	H
	10354.00	-56.16	-25	-31.16	-68.18	-57.68	10.48	12.00	H
	5177.00	-60.15	-25	-35.15	-65.58	-65.71	7.14	12.70	V
	7765.50	-53.38	-25	-28.38	-64.65	-56.68	8.30	11.60	V
	10354.00	-54.57	-25	-29.57	-68.39	-56.09	10.48	12.00	V

Remark: Spurious emissions within 30-1000MHz were found more than 20dB below limit line.



n78 SA / NR 100MHz / QPSK(ANT7)									
Channel	Frequency (MHz)	EIRP (dBm)	Limit (dBm)	Over Limit (dB)	SPA Reading (dBm)	S.G. Power (dBm)	TX Cable loss (dB)	TX Antenna Gain (dBi)	Polarization (H/V)
Middle	7401.00	-55.22	-13	-42.22	-48.71	-58.52	8.30	11.60	H
	11101.50	-54.24	-13	-41.24	-54.06	-55.76	10.48	12.00	H
	14802.00	-52.54	-13	-39.54	-54.90	-54.24	11.80	13.50	H
	7401.00	-55.90	-13	-42.90	-49.7	-59.20	8.30	11.60	V
	11101.50	-52.95	-13	-39.95	-52.5	-54.47	10.48	12.00	V
	14802.00	-50.38	-13	-37.38	-54.91	-52.08	11.80	13.50	V

Remark: Spurious emissions within 30-1000MHz were found more than 20dB below limit line.

EN-DC_41A_n78A / LTE 10MHz + NR 100MHz / QPSK (ANT1+3)									
Channel	Frequency (MHz)	EIRP (dBm)	Limit (dBm)	Over Limit (dB)	SPA Reading (dBm)	S.G. Power (dBm)	TX Cable loss (dB)	TX Antenna Gain (dBi)	Polarization (H/V)
NR n78 Middle	7401.00	-53.36	-13	-40.36	-46.85	-56.66	8.30	11.60	H
	11101.50	-53.58	-13	-40.58	-53.40	-55.10	10.48	12.00	H
	14802.00	-52.40	-13	-39.40	-54.76	-54.10	11.80	13.50	H
	7401.00	-55.71	-13	-42.71	-49.51	-59.01	8.30	11.60	V
	11101.50	-50.51	-13	-37.51	-50.06	-52.03	10.48	12.00	V
	14802.00	-50.90	-13	-37.90	-55.43	-52.60	11.80	13.50	V
LTE Band41 Middle	5177.00	-63.90	-25	-38.90	-51.25	-69.46	7.14	12.70	H
	7765.00	-58.98	-25	-33.98	-51.78	-62.28	8.30	11.60	H
	10354.00	-55.53	-25	-30.53	-53.71	-57.05	10.48	12.00	H
	5177.00	-64.15	-25	-39.15	-51.16	-69.71	7.14	12.70	V
	7765.00	-58.41	-25	-33.41	-51.86	-61.71	8.30	11.60	V
	10354.00	-56.78	-25	-31.78	-53.99	-58.30	10.48	12.00	V

Remark: Spurious emissions within 30-1000MHz were found more than 20dB below limit line.