



Partial FCC RF Test Report

APPLICANT : Motorola Mobility LLC
EQUIPMENT : Mobile Cellular Phone
BRAND NAME : Motorola
MODEL NAME : XT2427-1
FCC ID : IHDT56AN8
STANDARD : 47 CFR Part 2, 22, 24, 27, 90(S)
CLASSIFICATION : PCS Licensed Transmitter Held to Ear (PCE)
TEST DATE(S) : Apr. 16, 2024 ~ Apr. 26, 2024

We, Sporton International Inc. (ShenZhen), would like to declare that the tested sample has been evaluated in accordance with the procedures given in ANSI C63.26-2015 and shown compliance with the applicable technical standards.

The test results in this report apply exclusively to the tested model / sample. Without written approval of Sporton International Inc. (ShenZhen), the test report shall not be reproduced except in full.

Jason Jia



Approved by: Jason Jia

Sporton International Inc. (ShenZhen)

1/F, 2/F, Bldg 5, Shiling Industrial Zone, Xinwei Village, Xili, Nanshan, Shenzhen, 518055

People's Republic of China



TABLE OF CONTENTS

REVISION HISTORY... 3
SUMMARY OF TEST RESULT ... 4
1 GENERAL DESCRIPTION ... 5
1.1 Applicant ... 5
1.2 Manufacturer ... 5
1.3 Product Feature of Equipment Under Test ... 5
1.4 Product Specification of Equipment Under Test ... 5
1.5 Modification of EUT ... 6
1.6 Testing Location ... 6
1.7 Test Software ... 6
1.8 Applicable Standards ... 6
1.9 Specification of Accessory ... 7
2 TEST CONFIGURATION OF EQUIPMENT UNDER TEST ... 8
2.1 Test Mode ... 8
2.2 Connection Diagram of Test System ... 9
2.3 Support Unit used in test configuration and system ... 9
2.4 Frequency List of Low/Middle/High Channels ... 10
3 CONDUCTED TEST ITEMS ... 14
3.1 Measuring Instruments ... 14
3.2 Test Setup ... 14
3.3 Test Result of Conducted Test ... 14
3.4 Radiated Spurious Emission ... 15
4 LIST OF MEASURING EQUIPMENT ... 16
5 MEASUREMENT UNCERTAINTY ... 17
APPENDIX A. TEST RESULTS OF RADIATED TEST
APPENDIX B. TEST SETUP PHOTOGRAPHS



REVISION HISTORY

REPORT NO.	VERSION	DESCRIPTION	ISSUED DATE
FG432901G	Rev. 01	Initial issue of report	May 08, 2024



SUMMARY OF TEST RESULT

Report Section	FCC Rule	Description	Limit	Result	Remark
3.4	§2.1053 §22.917(a) §24.238(a) §27.53(h) §27.53(l)(2)	Radiated Spurious Emission (5G NR n5, n26) (5G NR n2) (5G NR n66) (5G NR n78)	< 43+10log ₁₀ (P[Watts])	PASS	Under limit 26.25 dB at 10064.00 MHz
	§2.1053 §27.53(m)(4)	Radiated Spurious Emission (5G NR n7, n41)	< 55+10log ₁₀ (P[Watts])		

Note: For Power/ERP/EIRP/conducted test items of 5G NR Bands, test report will be issued separately.

Conformity Assessment Condition:
1. The test results (PASS/FAIL) with all measurement uncertainty excluded are presented against the regulation limits or in accordance with the requirements stipulated by the applicant/manufacturer who shall bear all the risks of non-compliance that may potentially occur if measurement uncertainty is taken into account.
2. The measurement uncertainty please refer to each test result in the section "Measurement Uncertainty"
Disclaimer:
The product specifications of the EUT presented in the test report that may affect the test assessments are declared by the manufacturer who shall take full responsibility for the authenticity.



1 General Description

1.1 Applicant

Motorola Mobility LLC
222 W,Merchandise Mart Plaza, Chicago IL 60654 USA

1.2 Manufacturer

Motorola Mobility LLC
222 W,Merchandise Mart Plaza, Chicago IL 60654 USA

1.3 Product Feature of Equipment Under Test

Product Feature	
Equipment	Mobile Cellular Phone
Brand Name	Motorola
Model Name	XT2427-1
FCC ID	IHDT56AN8
IMEI Code	Radiation : 35069973009514/35069973009522
HW Version	DVT2
SW Version	U3UO34.31
EUT Stage	Identical Prototype

1.4 Product Specification of Equipment Under Test

Standards-related Product Specification	
Tx Frequency	5G NR n2 : 1850 MHz ~ 1910 MHz 5G NR n5 : 824 MHz ~ 849 MHz 5G NR n7 : 2500 MHz ~ 2570 MHz 5G NR n26 : 814 MHz ~ 824 MHz (Part90S) 5G NR n26 : 824 MHz ~ 849 MHz (Part22H) 5G NR n38 : 2570 MHz ~ 2620 MHz 5G NR n41 : 2496 MHz ~ 2690 MHz 5G NR n66 : 1710 MHz ~ 1780 MHz 5G NR n78: 3450 MHz ~ 3550 MHz
Rx Frequency	5G NR n2 : 1930 MHz ~ 1990 MHz 5G NR n5 : 869 MHz ~ 894 MHz 5G NR n7 : 2620 MHz ~ 2690 MHz 5G NR n26 : 859 MHz ~ 869 MHz (Part90S) 5G NR n26 : 869 MHz ~ 894 MHz (Part22H) 5G NR n38: 2570 MHz ~ 2620 MHz 5G NR n41 : 2496 MHz ~ 2690 MHz 5G NR n66 : 2110 MHz~ 2200 MHz 5G NR n78: 3450 MHz ~ 3550 MHz
Bandwidth	n2, n5, n26 : 5MHz / 10MHz / 15MHz / 20MHz n7 : 5MHz / 10MHz / 15MHz / 20MHz / 25MHz / 30MHz / 40MHz n38 : 20MHz / 30MHz / 40MHz



	n41, n78 : 20MHz / 30MHz / 40MHz / 50MHz / 60MHz / 70MHz / 80MHz / 90MHz / 100MHz n66 : 5MHz / 10MHz / 15MHz / 20MHz / 30MHz / 40MHz
SCS	15kHz for FDD, 30kHz for TDD
Type of Modulation	CP-OFDM: QPSK / 16QAM / 64QAM / 256QAM DFT-s-OFDM: PI/2 BPSK / QPSK / 16QAM / 64QAM / 256QAM

Remark:

1. The EN-DC mode combination could be referred to the product spec.
2. 5G NR n26 supports SA mode only, the other bands support SA/NSA mode.
3. There are two PA for 5G NR n2/n7/n66, Main PA for SA and other PA for NSA.

1.5 Modification of EUT

No modifications are made to the EUT during all test items.

1.6 Testing Location

Sporton International Inc. (ShenZhen) is accredited to ISO/IEC 17025:2017 by American Association for Laboratory Accreditation with Certificate Number 5145.01.

Test Firm	Sporton International Inc. (ShenZhen)		
Test Site Location	101, 1st Floor, Block B, Building 1, No. 2, Tengfeng 4th Road, Fenghuang Community, Fuyong Street, Baoan District, Shenzhen City, Guangdong Province 518103 People's Republic of China TEL: +86-755-86066985		
Test Site No.	Sporton Site No.	FCC Designation No.	FCC Test Firm Registration No.
	03CH03-SZ	CN1256	421272

1.7 Test Software

Item	Site	Manufacture	Name	Version
1.	03CH03-SZ	AUDIX	E3	6.2009-8-24

1.8 Applicable Standards

According to the specifications of the manufacturer, the EUT must comply with the requirements of the following standards:

- 47 CFR Part 2, 22, 24, 27, 90(S)
- ANSI C63.26-2015
- FCC KDB 971168 D01 Power Meas License Digital Systems v03r01



- FCC KDB 412172 D01 Determining ERP and EIRP v01r01

Remark:

All test items were verified and recorded according to the standards and without any deviation during the test.

1.9 Specification of Accessory

Specification of Accessory				
AC Adapter 1(US)	Brand Name	Motorola (Chenyang)	Model Name	MC-331
AC Adapter 1(EU)	Brand Name	Motorola (Chenyang)	Model Name	MC-332
AC Adapter 1(AU)	Brand Name	Motorola (Chenyang)	Model Name	MC-335
AC Adapter 1(AR)	Brand Name	Motorola (Chenyang)	Model Name	MC-336
AC Adapter 1(BR)	Brand Name	Motorola (Chenyang)	Model Name	MC-337
AC Adapter 2(US)	Brand Name	Motorola (AOHAI)	Model Name	MC-331
AC Adapter 2(EU)	Brand Name	Motorola (AOHAI)	Model Name	MC-332
AC Adapter 2(UK)	Brand Name	Motorola (AOHAI)	Model Name	MC-333
AC Adapter 2(IN)	Brand Name	Motorola (AOHAI)	Model Name	MC-334
AC Adapter 3(IN)	Brand Name	Motorola (Salcomp)	Model Name	MC-334
AC Adapter 3(CHILE)	Brand Name	Motorola (Salcomp)	Model Name	MC-339
AC Adapter 3(KR)	Brand Name	Motorola (Salcomp)	Model Name	MC-330
AC Adapter 4(IN)	Brand Name	Motorola (XIHU)	Model Name	MC-334
Battery 1	Brand Name	Motorola (SCUD)	Model Name	QE50
Battery 2	Brand Name	Motorola (COSMX)	Model Name	QE50
USB Cable 1	Brand Name	Motorola (hexin)	Model Name	S928E21807
USB Cable 2	Brand Name	Motorola (chuantuo)	Model Name	S928E21806
Earphone	Brand Name	Motorola (Lyand)	Model Name	MI181C



2 Test Configuration of Equipment Under Test

2.1 Test Mode

Antenna port conducted and radiated test items are performed according to KDB 971168 D01 Power Meas License Digital Systems v03r01 with maximum output power.

For radiated measurement, pre-scanned in three orthogonal panels, X, Y, Z. The worst cases (X plane) were recorded in this report.

The device is investigated from 30MHz to 10 times of fundamental signal for radiated spurious emission test under different RB size/offset and modulations in exploratory test. Subsequently, only the worst case emissions are reported.

Orthogonal Planes of EUT	X Plane	Y Plane	Z Plane
			

Test Items	5G NR	Bandwidth (MHz)													Modulation					RB #		Test Channel		
		5	10	15	20	25	30	40	50	60	70	80	90	100	PI/2 BPSK	QPSK	16QAM	64QAM	256QAM	1	Full	L	M	H
Radiated Spurious Emission	n2	Worst Case																					v	
	n5	Worst Case																					v	
	n7	Worst Case																					v	
	n26	Worst Case																					v	
	n41	Worst Case																					v	
	n66	Worst Case																					v	
	n78	Worst Case																					v	
Note	<ol style="list-style-type: none"> The mark "v" means that this configuration is chosen for testing The mark "-" means that this bandwidth is not supported. The device is investigated from 30MHz to 10 times of fundamental signal for radiated spurious emission test under different RB size/offset and modulations in exploratory test. Subsequently, only the worst case emissions are reported. Frequency Stability : Normal Voltage = 3.91V ; Low Voltage =3.60V. ; High Voltage =4.50V 5G NR n41 overlaps the entire frequency range of 5G NR n38. Therefore, the test results provided in this report covers 5G NR n41 as well as 5G NR n38. 																							

2.2 Connection Diagram of Test System

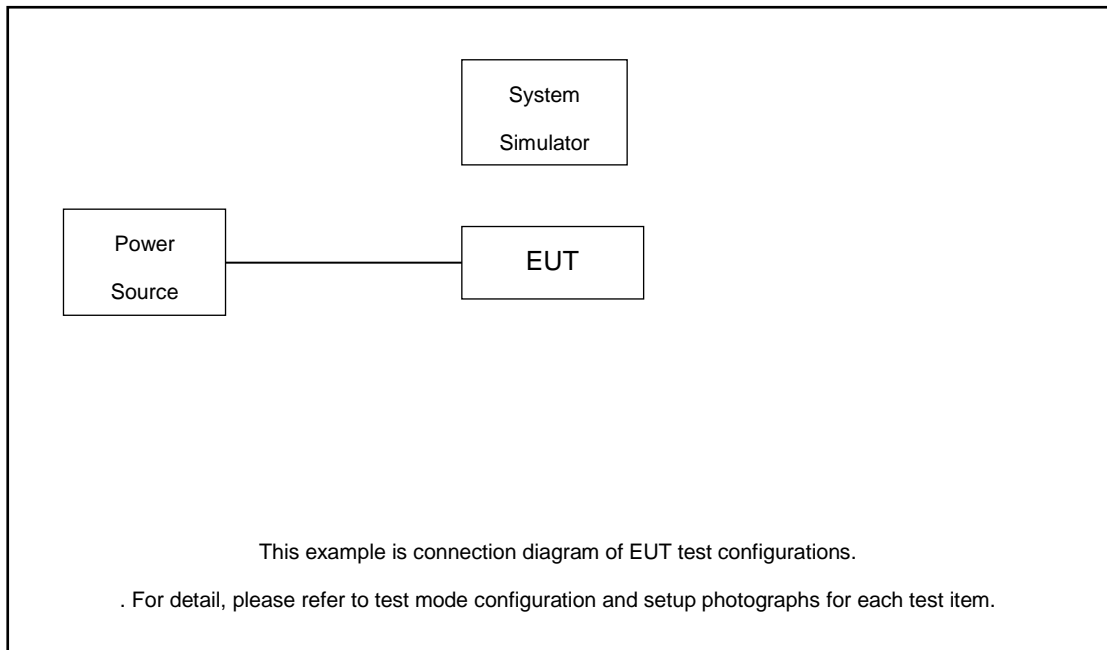

The EUT has been configuration operated in a manner tended to maximize its emission characteristics in a typical application.

2.3 Support Unit used in test configuration and system

Item	Equipment	Trade Name	Model No.	FCC ID	Data Cable	Power Cord
1.	Base Station	Anritsu	MT8821C	N/A	N/A	Unshielded, 1.8 m
2.	Base Station	Anritsu	MT8000A	N/A	N/A	Unshielded, 1.8 m



2.4 Frequency List of Low/Middle/High Channels

5G NR n2 Channel and Frequency List				
BW [MHz]	Channel/Frequency(MHz)	Lowest	Middle	Highest
20	Channel	372000	376000	380000
	Frequency	1860	1880	1900
15	Channel	371500	376000	380500
	Frequency	1857.5	1880	1902.5
10	Channel	371000	376000	381000
	Frequency	1855	1880	1905
5	Channel	370500	376000	381500
	Frequency	1852.5	1880	1907.5

5G NR n5 Channel and Frequency List				
BW [MHz]	Channel/Frequency(MHz)	Lowest	Middle	Highest
20	Channel	166800	167300	167800
	Frequency	834	836.5	839
15	Channel	166300	167300	168300
	Frequency	831.5	836.5	841.5
10	Channel	165800	167300	168800
	Frequency	829	836.5	844
5	Channel	165300	167300	169300
	Frequency	826.5	836.5	846.5



5G NR n7 Channel and Frequency List				
BW [MHz]	Channel/Frequency(MHz)	Lowest	Middle	Highest
40	Channel	504000	507000	510000
	Frequency	2520	2535	2550
30	Channel	503000	507000	511000
	Frequency	2515	2535	2555
25	Channel	502500	507000	511500
	Frequency	2512.5	2535	2557.5
20	Channel	502000	507000	512000
	Frequency	2510	2535	2560
15	Channel	501500	507000	512500
	Frequency	2507.5	2535	2562.5
10	Channel	501000	507000	513000
	Frequency	2505	2535	2565
5	Channel	500500	507000	513500
	Frequency	2502.5	2535	2567.5

5G NR n26 Channel and Frequency List				
BW [MHz]	Channel/Frequency(MHz)	Lowest	Middle	Highest
20	Channel	166800	167300	167800
	Frequency	834	836.5	839
15	Channel	166300	167300	168300
	Frequency	831.5	836.5	841.5
10	Channel	165800	167300	168800
	Frequency	829	836.5	844
5	Channel	165300	167300	169300
	Frequency	826.5	836.5	846.5



5G NR n38 Channel and Frequency List				
BW [MHz]	Channel/Frequency(MHz)	Lowest	Middle	Highest
40	Channel	518000	519000	520000
	Frequency	2590	2595	2600
30	Channel	517000	519000	521000
	Frequency	2585	2595	2605
20	Channel	516000	519000	522000
	Frequency	2580	2595	2610

5G NR n41 Channel and Frequency List				
BW [MHz]	Channel/Frequency(MHz)	Lowest	Middle	Highest
100	Channel	509202	518598	528000
	Frequency	2546.01	2592.99	2640
90	Channel	508200	518598	528996
	Frequency	2541	2592.99	2644.98
80	Channel	507204	518598	529998
	Frequency	2536.02	2592.99	2649.99
70	Channel	506202	518598	531000
	Frequency	2531.01	2592.99	2655
60	Channel	505200	518598	531996
	Frequency	2526	2592.99	2659.98
50	Channel	504204	518598	532998
	Frequency	2521.02	2592.99	2664.99
40	Channel	503202	518598	534000
	Frequency	2516.01	2592.99	2670
30	Channel	502200	518598	534996
	Frequency	2511	2592.99	2674.98
20	Channel	501204	518598	535998
	Frequency	2506.02	2592.99	2679.99



5G NR n66 Channel and Frequency List				
BW [MHz]	Channel/Frequency(MHz)	Lowest	Middle	Highest
40	Channel	346000	349000	352000
	Frequency	1730	1745	1760
30	Channel	345000	349000	353000
	Frequency	1725	1745	1765
20	Channel	344000	349000	354000
	Frequency	1720	1745	1770
15	Channel	343500	349000	354500
	Frequency	1717.5	1745	1772.5
10	Channel	343000	349000	355000
	Frequency	1715	1745	1775
5	Channel	342500	349000	355500
	Frequency	1712.5	1745	1777.5

5G n78 Channel and Frequency List				
BW [MHz]	Channel/Frequency(MHz)	Lowest	Middle	Highest
100	Channel	-	633334	-
	Frequency	-	3500.01	-
90	Channel	633000	633334	633666
	Frequency	3495	3500.01	3504.99
80	Channel	632668	633334	634000
	Frequency	3490.02	3500.01	3510
70	Channel	632334	633334	634332
	Frequency	3485.01	3500.01	3514.98
60	Channel	632000	633334	634666
	Frequency	3480	3500.01	3519.99
50	Channel	631668	633334	635000
	Frequency	3475.02	3500.01	3525
40	Channel	631334	633334	635332
	Frequency	3470.01	3500.01	3529.98
30	Channel	631000	633334	635666
	Frequency	3465	3500.01	3534.99
20	Channel	630668	633334	636000
	Frequency	3460.02	3500.01	3540

3 Conducted Test Items

3.1 Measuring Instruments

See list of measuring instruments of this test report.

3.2 Test Setup

3.2.1 Conducted Output Power



3.2.2 Peak-to-Average Ratio, Occupied Bandwidth ,Conducted Band-Edge and Conducted Spurious Emission

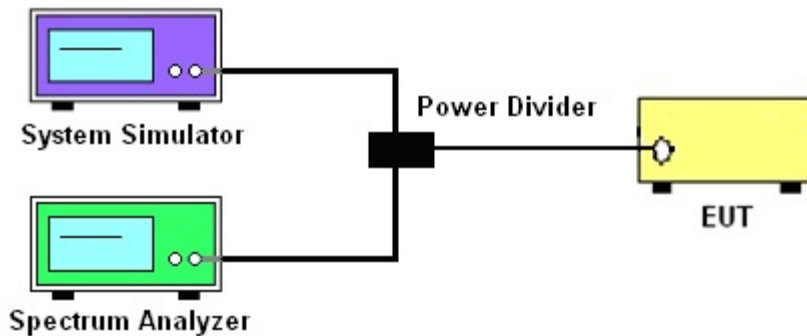

3.2.3 Frequency Stability

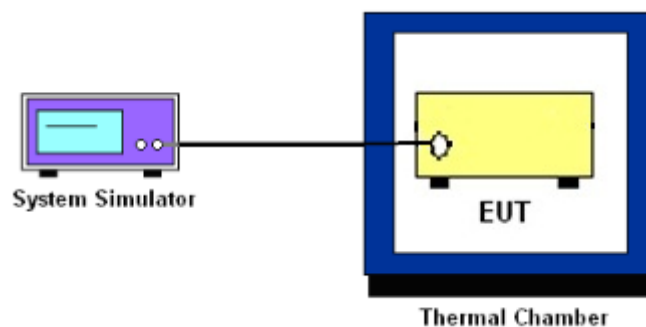

3.3 Test Result of Conducted Test

Please refer to Appendix A.



3.4 Radiated Spurious Emission

3.4.1 Description of Radiated Spurious Emission

The radiated spurious emission was measured by substitution method according to ANSI C63.26. The power of any emission outside of the authorized operating frequency ranges must be attenuated below the transmitter power (P) by a factor of at least $43 + 10 \log (P)$ dB.

For 5G NR n7/n38/n41

The power of any emission outside of the authorized operating frequency ranges must be attenuated below the transmitter power (P) by a factor of at least $55 + 10 \log (P)$ dB.

The spectrum is scanned from 30 MHz up to a frequency including its 10th harmonic.

3.4.2 Test Procedures

1. The testing follows ANSI C63.26 Section 5.5
2. The EUT was placed on a turntable with 0.8 meter height for frequency below 1GHz and 1.5 meter height for frequency above 1GHz respectively above ground.
3. The EUT was set 3 meters from the receiving antenna mounted on the antenna tower.
4. The table was rotated 360 degrees to determine the position of the highest spurious emission.
5. The height of the receiving antenna is varied between 1m to 4m to search the maximum spurious emission for both horizontal and vertical polarizations.
6. During the measurement, the system simulator parameters were set to force the EUT transmitting at maximum output power.
7. Make the measurement with the spectrum analyzer's RBW = 1MHz, VBW = 3MHz, taking the record of maximum spurious emission.
8. A horn antenna was substituted in place of the EUT and was driven by a signal generator.
9. Tune the output power of signal generator to the same emission level with EUT maximum spurious emission.
10. $EIRP (dBm) = S.G. Power - Tx Cable Loss + Tx Antenna Gain$
11. $ERP (dBm) = EIRP - 2.15$
12. The RF fundamental frequency should be excluded against the limit line in the operating frequency band.

The limit line is derived from $43 + 10\log(P)$ dB below the transmitter power P(Watts)
 $= P(W) - [43 + 10\log(P)] (dB)$
 $= [30 + 10\log(P)] (dBm) - [43 + 10\log(P)] (dB)$
 $= -13dBm.$

13. For 5G NR n7/n38/n41:

The limit line is derived from $55 + 10\log(P)$ dB below the transmitter power P(Watts)The limit line is derived from $55 + 10\log(P)$ dB below the transmitter power P(Watts)



4 List of Measuring Equipment

Instrument	Manufacturer	Model No.	Serial No.	Characteristics	Calibration Date	Test Date	Due Date	Remark
EMI Test Receiver&SA	KEYSIGHT	N9038A	MY54450083	20Hz~8.4GHz	Apr. 09, 2024	Apr. 16, 2024~ Apr. 26, 2024	Apr. 08, 2025	Radiation (03CH03-SZ)
Loop Antenna	R&S	HFH2-Z2	100354	9kHz~30MHz	Jun. 28, 2022	Apr. 16, 2024~ Apr. 26, 2024	Jun. 27, 2024	Radiation (03CH03-SZ)
EXA Spectrum Analyzer	KEYSIGHT	N9010A	MY55150246	10Hz~44GHz;	Apr. 09, 2024	Apr. 16, 2024~ Apr. 26, 2024	Apr. 08, 2025	Radiation (03CH03-SZ)
Bilog Antenna	TeseQ	CBL6112D	35408	30MHz~2GHz	Aug. 20, 2023	Apr. 16, 2024~ Apr. 26, 2024	Aug. 19, 2025	Radiation (03CH03-SZ)
Double Ridge Horn Antenna	SCHWARZBECK	BBHA9120D	9120D-1355	1GHz~18GHz	Apr. 09, 2024	Apr. 16, 2024~ Apr. 26, 2024	Apr. 08, 2025	Radiation (03CH03-SZ)
Amplifier	Burgeon	BPA-530	102211	0.01Hz ~3000MHz	Oct. 18, 2023	Apr. 16, 2024~ Apr. 26, 2024	Oct. 17, 2024	Radiation (03CH03-SZ)
HF Amplifier	MITEQ	TTA1840-35-HG	1871923	18GHz~40GHz	Jul. 07, 2023	Apr. 16, 2024~ Apr. 26, 2024	Jul.06, 2024	Radiation (03CH03-SZ)
SHF-EHF Horn	com-power	AH-840	101071	18Ghz-40GHz	Apr. 09, 2024	Apr. 16, 2024~ Apr. 26, 2024	Apr. 08, 2025	Radiation (03CH03-SZ)
Amplifier	Agilent Technologies	83017A	MY39501302	500MHz~26.5GHz	Dec. 27, 2023	Apr. 16, 2024~ Apr. 26, 2024	Dec. 26, 2024	Radiation (03CH03-SZ)
AC Power Source	Chroma	61601	616010002729	N/A	Oct. 18, 2023	Apr. 16, 2024~ Apr. 26, 2024	Oct. 17, 2024	Radiation (03CH03-SZ)
Turn Table	EM	EM1000	N/A	0~360 degree	NCR	Apr. 16, 2024~ Apr. 26, 2024	NCR	Radiation (03CH03-SZ)
Antenna Mast	EM	EM1000	N/A	1 m~4 m	NCR	Apr. 16, 2024~ Apr. 26, 2024	NCR	Radiation (03CH03-SZ)

NCR: No Calibration Required



5 Measurement Uncertainty

The measurement uncertainties shown below were calculated in accordance with the requirements of ANSI 63.26-2015. All the measurement uncertainty value were shown with a coverage K=2 to indicate 95% level of confidence. The measurement data show herein meets or exceeds the CISPR measurement uncertainty values specified in CISPR 16-4-2 and can be compared directly to specified limit to determine compliance.

Uncertainty of Radiated Emission Measurement (30 MHz ~ 1000 MHz)

Measuring Uncertainty for a Level of Confidence of 95% (U = 2Uc(y))	3.0 dB
---	--------

Uncertainty of Radiated Emission Measurement (1 GHz ~ 18 GHz)

Measuring Uncertainty for a Level of Confidence of 95% (U = 2Uc(y))	3.6 dB
---	--------

Uncertainty of Radiated Emission Measurement (18 GHz ~ 40 GHz)

Measuring Uncertainty for a Level of Confidence of 95% (U = 2Uc(y))	3.8 dB
---	--------

----- THE END -----



Appendix A. Test Results of Radiated Test

Radiated Spurious Emission

Test Engineer :	Qingsheng He	Temperature :	22~25°C
		Relative Humidity :	48~52%

Note: Pre-scanned harmonic for the different antenna combinations, we choose the worst antenna mode to perform final test.

n2 SA / NR 20MHz / QPSK(ANT1)									
Channel	Frequency (MHz)	EIRP (dBm)	Limit (dBm)	Over Limit (dB)	SPA Reading (dBm)	S.G. Power (dBm)	TX Cable loss (dB)	TX Antenna Gain (dBi)	Polarization (H/V)
Middle	3741.5	-53.78	-13	-40.78	-68.41	-60.53	5.85	12.60	H
	5612.25	-61.36	-13	-48.36	-79.08	-67.16	7.30	13.10	H
	7483	-56.39	-13	-43.39	-78.80	-59.54	8.35	11.50	H
	3741.5	-56.70	-13	-43.70	-71.54	-63.45	5.85	12.60	V
	5612.25	-62.01	-13	-49.01	-79.64	-67.81	7.30	13.10	V
	7483	-55.29	-13	-42.29	-77.64	-58.44	8.35	11.50	V

Remark: Spurious emissions within 30-1000MHz were found more than 20dB below limit line.

EN-DC_7A_n2A / LTE 10MHz + NR 20MHz / QPSK (ANT1+4) for other PA									
Channel	Frequency (MHz)	EIRP (dBm)	Limit (dBm)	Over Limit (dB)	SPA Reading (dBm)	S.G. Power (dBm)	TX Cable loss (dB)	TX Antenna Gain (dBi)	Polarization (H/V)
NR n2 Middle	3741.5	-59.99	-13	-46.99	-74.62	-66.74	5.85	12.60	H
	5612.25	-60.47	-13	-47.47	-78.19	-66.27	7.30	13.10	H
	7483	-55.81	-13	-42.81	-78.22	-58.96	8.35	11.50	H
	3741.5	-61.33	-13	-48.33	-76.17	-68.08	5.85	12.60	V
	5612.25	-61.99	-13	-48.99	-79.62	-67.79	7.30	13.10	V
	7483	-55.40	-13	-42.40	-77.75	-58.55	8.35	11.50	V
LTE Band7 Middle	5052.18	-62.21	-25	-37.21	-79.63	-67.77	7.14	12.70	H
	7578.27	-56.24	-25	-31.24	-78.43	-59.54	8.30	11.60	H
	10104.36	-51.92	-25	-26.92	-79.01	-53.44	10.48	12.00	H
	5052.18	-62.20	-25	-37.20	-79.55	-67.76	7.14	12.70	V
	7578.27	-56.36	-25	-31.36	-78.35	-59.66	8.30	11.60	V
	10104.36	-52.42	-25	-27.42	-79.02	-53.94	10.48	12.00	V

Remark: Spurious emissions within 30-1000MHz were found more than 20dB below limit line.



EN-DC_66A_n2A / LTE 10MHz + NR 20MHz / QPSK (ANT1+4)									
Channel	Frequency (MHz)	EIRP (dBm)	Limit (dBm)	Over Limit (dB)	SPA Reading (dBm)	S.G. Power (dBm)	TX Cable loss (dB)	TX Antenna Gain (dBi)	Polarization (H/V)
NR n2 Middle	3744	-61.88	-13	-48.88	-76.51	-68.63	5.85	12.60	H
	5619	-62.40	-13	-49.40	-80.12	-68.20	7.30	13.10	H
	7492	-56.95	-13	-43.95	-79.31	-60.10	8.35	11.50	H
	3738	-63.29	-13	-50.29	-78.12	-70.04	5.85	12.60	V
	5619	-62.18	-13	-49.18	-79.81	-67.98	7.30	13.10	V
	7492	-56.72	-13	-43.72	-79	-59.87	8.35	11.50	V
LTE Band66 Middle	3472	-65.02	-13	-52.02	-77.84	-71.87	5.65	12.50	H
	5208	-63.16	-13	-50.16	-80.62	-68.83	7.13	12.80	H
	6944	-58.89	-13	-45.89	-79.80	-62.29	8.40	11.80	H
	3472	-64.67	-13	-51.67	-78.04	-71.52	5.65	12.50	V
	5208	-63.31	-13	-50.31	-80.72	-68.98	7.13	12.80	V
	6944	-58.79	-13	-45.79	-79.75	-62.19	8.40	11.80	V

Remark: Spurious emissions within 30-1000MHz were found more than 20dB below limit line.

n5 SA / NR 20MHz / QPSK(ANT0)									
Channel	Frequency (MHz)	ERP (dBm)	Limit (dBm)	Over Limit (dB)	SPA Reading (dBm)	S.G. Power (dBm)	TX Cable loss (dB)	TX Antenna Gain (dBi)	Polarization (H/V)
Middle	1654.5	-68.35	-13	-55.35	-74.63	-71.60	4.00	9.40	H
	2481.75	-65.22	-13	-52.22	-75.54	-68.79	4.88	10.60	H
	3309	-64.71	-13	-51.71	-77.04	-69.64	5.52	12.60	H
	1654.5	-68.51	-13	-55.51	-74.64	-71.76	4.00	9.40	V
	2481.75	-64.75	-13	-51.75	-75.43	-68.32	4.88	10.60	V
	3309	-63.96	-13	-50.96	-76.73	-68.89	5.52	12.60	V

Remark: Spurious emissions within 30-1000MHz were found more than 20dB below limit line.

EN-DC_2A_n5A / LTE 10MHz + NR 20MHz / QPSK (ANT1+4)									
Channel	Frequency (MHz)	ERP/EIRP (dBm)	Limit (dBm)	Over Limit (dB)	SPA Reading (dBm)	S.G. Power (dBm)	TX Cable loss (dB)	TX Antenna Gain (dBi)	Polarization (H/V)
NR n5 Middle	1654.5	-52.81	-13	-39.81	-59.09	-56.06	4.00	9.40	H
	2481.75	-57.62	-13	-44.62	-67.94	-61.19	4.88	10.60	H
	3309	-62.56	-13	-49.56	-74.89	-67.49	5.52	12.60	H
	1654.5	-52.63	-13	-39.63	-58.76	-55.88	4.00	9.40	V
	2481.75	-58.75	-13	-45.75	-69.43	-62.32	4.88	10.60	V
	3309	-63.29	-13	-50.29	-76.06	-68.22	5.52	12.60	V
LTE Band2 Middle	3742.18	-63.27	-13	-50.27	-77.90	-70.02	5.85	12.60	H
	5613.27	-62.26	-13	-49.26	-79.98	-68.06	7.30	13.10	H
	7484.36	-56.60	-13	-43.60	-79.01	-59.75	8.35	11.50	H
	3742.18	-63.21	-13	-50.21	-78.05	-69.96	5.85	12.60	V
	5613.27	-62.21	-13	-49.21	-79.84	-68.01	7.30	13.10	V
	7484.36	-56.63	-13	-43.63	-78.97	-59.78	8.35	11.50	V

Remark: Spurious emissions within 30-1000MHz were found more than 20dB below limit line.



n7 SA / NR 20MHz / QPSK(ANT1)									
Channel	Frequency (MHz)	EIRP (dBm)	Limit (dBm)	Over Limit (dB)	SPA Reading (dBm)	S.G. Power (dBm)	TX Cable loss (dB)	TX Antenna Gain (dBi)	Polarization (H/V)
Middle	5032.00	-63.35	-25	-38.35	-80.75	-68.91	7.14	12.70	H
	7548.00	-55.93	-25	-30.93	-78.18	-59.23	8.30	11.60	H
	10064.00	-52.46	-25	-27.46	-79.56	-53.98	10.48	12.00	H
	5032.00	-63.94	-25	-38.94	-81.26	-69.50	7.14	12.70	V
	7548.00	-56.68	-25	-31.68	-78.77	-59.98	8.30	11.60	V
	10064.00	-52.54	-25	-27.54	-79.11	-54.06	10.48	12.00	V

Remark: Spurious emissions within 30-1000MHz were found more than 20dB below limit line.

EN-DC_5A_n7A / LTE 10MHz + NR 40MHz / QPSK (ANT4+1)									
Channel	Frequency (MHz)	EIRP/ERP (dBm)	Limit (dBm)	Over Limit (dB)	SPA Reading (dBm)	S.G. Power (dBm)	TX Cable loss (dB)	TX Antenna Gain (dBi)	Polarization (H/V)
NR n7 Middle	5032.00	-62.00	-25	-37.00	-79.40	-67.56	7.14	12.70	H
	7548.00	-53.50	-25	-28.50	-75.75	-56.80	8.30	11.60	H
	10064.00	-52.32	-25	-27.32	-79.42	-53.84	10.48	12.00	H
	5032.00	-62.55	-25	-37.55	-79.87	-68.11	7.14	12.70	V
	7548.00	-53.66	-25	-28.66	-75.75	-56.96	8.30	11.60	V
	10064.00	-52.68	-25	-27.68	-79.25	-54.20	10.48	12.00	V
LTE Band5 Middle	1664.18	-63.15	-13	-50.15	-69.40	-66.40	4.00	9.40	H
	2496.27	-52.86	-13	-39.86	-63.15	-56.43	4.88	10.60	H
	3328.36	-64.75	-13	-51.75	-76.92	-69.68	5.52	12.60	H
	1664.18	-63.55	-13	-50.55	-69.57	-66.80	4.00	9.40	V
	2496.27	-53.64	-13	-40.64	-64.27	-57.21	4.88	10.60	V
	3328.36	-64.16	-13	-51.16	-76.74	-69.09	5.52	12.60	V

Remark: Spurious emissions within 30-1000MHz were found more than 20dB below limit line.

EN-DC_2A_n7A / LTE 10MHz + NR 20MHz / QPSK (ANT1+4) for other PA									
Channel	Frequency (MHz)	EIRP (dBm)	Limit (dBm)	Over Limit (dB)	SPA Reading (dBm)	S.G. Power (dBm)	TX Cable loss (dB)	TX Antenna Gain (dBi)	Polarization (H/V)
NR n7 Middle	5032.00	-62.28	-25	-37.28	-79.68	-67.84	7.14	12.70	H
	7548.00	-55.66	-25	-30.66	-77.91	-58.96	8.30	11.60	H
	10064.00	-51.25	-25	-26.25	-78.35	-52.77	10.48	12.00	H
	5032.00	-62.21	-25	-37.21	-79.53	-67.77	7.14	12.70	V
	7548.00	-55.90	-25	-30.90	-77.99	-59.20	8.30	11.60	V
	10064.00	-51.83	-25	-26.83	-78.4	-53.35	10.48	12.00	V
LTE Band2 Middle	3751.18	-62.44	-13	-49.44	-77.08	-69.19	5.85	12.60	H
	5626.77	-61.74	-13	-48.74	-79.47	-67.54	7.30	13.10	H
	7502.36	-55.96	-13	-42.96	-78.29	-59.11	8.35	11.50	H
	3751.18	-62.27	-13	-49.27	-77.11	-69.02	5.85	12.60	V
	5626.77	-61.86	-13	-48.86	-79.5	-67.66	7.30	13.10	V
	7502.36	-56.08	-13	-43.08	-78.31	-59.23	8.35	11.50	V

Remark: Spurious emissions within 30-1000MHz were found more than 20dB below limit line.



n26 SA / NR 20MHz / QPSK(ANT0)									
Channel	Frequency (MHz)	ERP (dBm)	Limit (dBm)	Over Limit (dB)	SPA Reading (dBm)	S.G. Power (dBm)	TX Cable loss (dB)	TX Antenna Gain (dBi)	Polarization (H/V)
Middle	1654.2	-68.60	-13	-55.60	-74.88	-71.85	4.00	9.40	H
	2481.3	-65.46	-13	-52.46	-75.78	-69.03	4.88	10.60	H
	3308.4	-64.56	-13	-51.56	-76.90	-69.49	5.52	12.60	H
	1654.2	-68.78	-13	-55.78	-74.91	-72.03	4.00	9.40	V
	2481.3	-65.04	-13	-52.04	-75.72	-68.61	4.88	10.60	V
	3308.4	-64.12	-13	-51.12	-76.90	-69.05	5.52	12.60	V

Remark: Spurious emissions within 30-1000MHz were found more than 20dB below limit line.

n26(90S) SA / NR 20MHz / QPSK(ANT0)									
Channel	Frequency (MHz)	ERP (dBm)	Limit (dBm)	Over Limit (dB)	SPA Reading (dBm)	S.G. Power (dBm)	TX Cable loss (dB)	TX Antenna Gain (dBi)	Polarization (H/V)
Middle	1645	-69.02	-13	-56.02	-75.29	-72.27	4.00	9.40	H
	2467.5	-66.09	-13	-53.09	-76.46	-69.66	4.88	10.60	H
	3290	-64.94	-13	-51.94	-77.42	-69.87	5.52	12.60	H
	1645	-68.89	-13	-55.89	-75.08	-72.14	4.00	9.40	V
	2467.5	-65.46	-13	-52.46	-76.19	-69.03	4.88	10.60	V
	3290	-64.48	-13	-51.48	-77.43	-69.41	5.52	12.60	V

Remark: Spurious emissions within 30-1000MHz were found more than 20dB below limit line.

n41 SA / NR 20MHz / QPSK(ANT1)									
Channel	Frequency (MHz)	EIRP (dBm)	Limit (dBm)	Over Limit (dB)	SPA Reading (dBm)	S.G. Power (dBm)	TX Cable loss (dB)	TX Antenna Gain (dBi)	Polarization (H/V)
Middle	5089.00	-63.12	-25	-38.12	-80.57	-68.68	7.14	12.70	H
	7633.50	-56.72	-25	-31.72	-78.98	-60.02	8.30	11.60	H
	10178.00	-52.77	-25	-27.77	-79.83	-54.29	10.48	12.00	H
	5089.00	-63.30	-25	-38.30	-80.68	-68.86	7.14	12.70	V
	7633.50	-56.76	-25	-31.76	-78.83	-60.06	8.30	11.60	V
	10178.00	-53.11	-25	-28.11	-79.76	-54.63	10.48	12.00	V

Remark: Spurious emissions within 30-1000MHz were found more than 20dB below limit line.



EN-DC_2A_n41A / LTE 10MHz + NR 100MHz / QPSK (ANT4+1)									
Channel	Frequency (MHz)	EIRP (dBm)	Limit (dBm)	Over Limit (dB)	SPA Reading (dBm)	S.G. Power (dBm)	TX Cable loss (dB)	TX Antenna Gain (dBi)	Polarization (H/V)
NR n41 Middle	5088.00	-62.34	-25	-37.34	-79.79	-67.90	7.14	12.70	H
	7633.50	-56.33	-25	-31.33	-78.59	-59.63	8.30	11.60	H
	10178.00	-51.85	-25	-26.85	-78.91	-53.37	10.48	12.00	H
	5088.00	-61.68	-25	-36.68	-79.06	-67.24	7.14	12.70	V
	7633.50	-56.69	-25	-31.69	-78.76	-59.99	8.30	11.60	V
	10178.00	-52.74	-25	-27.74	-79.39	-54.26	10.48	12.00	V
LTE Band2 Middle	3751.18	-63.31	-13	-50.31	-77.95	-70.06	5.85	12.60	H
	5626.77	-62.78	-13	-49.78	-80.51	-68.58	7.30	13.10	H
	7502.36	-56.69	-13	-43.69	-79.02	-59.84	8.35	11.50	H
	3751.18	-63.08	-13	-50.08	-77.92	-69.83	5.85	12.60	V
	5626.77	-62.77	-13	-49.77	-80.41	-68.57	7.30	13.10	V
	7502.36	-56.47	-13	-43.47	-78.7	-59.62	8.35	11.50	V

Remark: Spurious emissions within 30-1000MHz were found more than 20dB below limit line.

66 SA / NR 40MHz / QPSK(ANT1)									
Channel	Frequency (MHz)	EIRP (dBm)	Limit (dBm)	Over Limit (dB)	SPA Reading (dBm)	S.G. Power (dBm)	TX Cable loss (dB)	TX Antenna Gain (dBi)	Polarization (H/V)
Middle	3452	-63.65	-13	-50.65	-76.24	-70.50	5.65	12.50	H
	5178	-61.74	-13	-48.74	-79.28	-67.41	7.13	12.80	H
	6904	-57.71	-13	-44.71	-78.44	-61.11	8.40	11.80	H
	3452	-63.21	-13	-50.21	-76.35	-70.06	5.65	12.50	V
	5178	-61.22	-13	-48.22	-78.7	-66.89	7.13	12.80	V
	6904	-58.00	-13	-45.00	-78.66	-61.40	8.40	11.80	V

Remark: Spurious emissions within 30-1000MHz were found more than 20dB below limit line.

EN-DC_5A_n66A / LTE 10MHz + NR 40MHz / QPSK (ANT4+1)									
Channel	Frequency (MHz)	EIRP (dBm)	Limit (dBm)	Over Limit (dB)	SPA Reading (dBm)	S.G. Power (dBm)	TX Cable loss (dB)	TX Antenna Gain (dBi)	Polarization (H/V)
NR n66 Middle	3452	-61.36	-13	-48.36	-73.95	-68.21	5.65	12.50	H
	5178	-61.09	-13	-48.09	-78.63	-66.76	7.13	12.80	H
	6904	-58.56	-13	-45.56	-79.29	-61.96	8.40	11.80	H
	3452	-62.89	-13	-49.89	-76.03	-69.74	5.65	12.50	V
	5178	-62.56	-13	-49.56	-80.04	-68.23	7.13	12.80	V
	6904	-58.36	-13	-45.36	-79.02	-61.76	8.40	11.80	V
LTE Band5 Middle	1664.18	-67.00	-13	-54.00	-73.25	-70.25	4.00	9.40	H
	2496.27	-64.33	-13	-51.33	-74.62	-67.90	4.88	10.60	H
	3328.36	-64.68	-13	-51.68	-76.85	-69.61	5.52	12.60	H
	1664.18	-65.63	-13	-52.63	-71.65	-68.88	4.00	9.40	V
	2496.27	-64.76	-13	-51.76	-75.39	-68.33	4.88	10.60	V
	3328.36	-64.45	-13	-51.45	-77.03	-69.38	5.52	12.60	V

Remark: Spurious emissions within 30-1000MHz were found more than 20dB below limit line.



EN-DC_7A_n66A / LTE 10MHz + NR 40MHz / QPSK (ANT1+4) for other PA									
Channel	Frequency (MHz)	EIRP (dBm)	Limit (dBm)	Over Limit (dB)	SPA Reading (dBm)	S.G. Power (dBm)	TX Cable loss (dB)	TX Antenna Gain (dBi)	Polarization (H/V)
NR n66 Middle	3452	-60.66	-13	-47.66	-73.25	-67.51	5.65	12.50	H
	5178	-62.30	-13	-49.30	-79.84	-67.97	7.13	12.80	H
	6904	-58.45	-13	-45.45	-79.18	-61.85	8.40	11.80	H
	3452	-62.24	-13	-49.24	-75.38	-69.09	5.65	12.50	V
	5178	-62.40	-13	-49.40	-79.88	-68.07	7.13	12.80	V
	6904	-58.31	-13	-45.31	-78.97	-61.71	8.40	11.80	V
LTE Band7 Middle	5052.18	-62.66	-25	-37.66	-80.08	-68.22	7.14	12.70	H
	7578.27	-56.22	-25	-31.22	-78.41	-59.52	8.30	11.60	H
	10104.36	-51.95	-25	-26.95	-79.04	-53.47	10.48	12.00	H
	5052.18	-62.13	-25	-37.13	-79.48	-67.69	7.14	12.70	V
	7578.27	-56.33	-25	-31.33	-78.32	-59.63	8.30	11.60	V
	10104.36	-52.47	-25	-27.47	-79.07	-53.99	10.48	12.00	V

Remark: Spurious emissions within 30-1000MHz were found more than 20dB below limit line.

N78 SA / NR 100MHz / QPSK(ANT3)									
Channel	Frequency (MHz)	EIRP (dBm)	Limit (dBm)	Over Limit (dB)	SPA Reading (dBm)	S.G. Power (dBm)	TX Cable loss (dB)	TX Antenna Gain (dBi)	Polarization (H/V)
Middle	6901.5	-58.74	-13	-45.74	-54.08	-60.26	11.98	13.50	H
	10352.25	-49.54	-13	-36.54	-50.66	-49.54	13.60	13.60	H
	13803	-51.25	-13	-38.25	-57.72	-50.85	15.50	15.10	H
	6901.5	-61.48	-13	-48.48	-56.74	-63.00	11.98	13.50	V
	10352.25	-52.89	-13	-39.89	-53.8	-52.89	13.60	13.60	V
	13803	-51.59	-13	-38.59	-57.75	-51.19	15.50	15.10	V

Remark: Spurious emissions within 30-1000MHz were found more than 20dB below limit line.

EN-DC_41A_n78A / LTE 10MHz + NR 100MHz / QPSK (ANT1+3)									
Channel	Frequency (MHz)	EIRP (dBm)	Limit (dBm)	Over Limit (dB)	SPA Reading (dBm)	S.G. Power (dBm)	TX Cable loss (dB)	TX Antenna Gain (dBi)	Polarization (H/V)
NR n78 Middle	6901.5	-59.59	-13	-46.59	-54.93	-61.11	11.98	13.50	H
	10352.25	-49.06	-13	-36.06	-50.18	-49.06	13.60	13.60	H
	13803	-51.27	-13	-38.27	-57.74	-50.87	15.50	15.10	H
	6901.5	-60.15	-13	-47.15	-55.41	-61.67	11.98	13.50	V
	10352.25	-44.09	-13	-31.09	-45	-44.09	13.60	13.60	V
	13803	-51.29	-13	-38.29	-57.45	-50.89	15.50	15.10	V
LTE Band41 Middle	5168.00	-62.84	-25	-37.84	-80.36	-68.40	7.14	12.70	H
	7752.00	-59.37	-25	-34.37	-56.48	-62.67	8.30	11.60	H
	10336.00	-56.18	-25	-31.18	-57.29	-57.70	10.48	12.00	H
	5168.00	-62.99	-25	-37.99	-80.46	-68.55	7.14	12.70	V
	7752.00	-59.37	-25	-34.37	-56.45	-62.67	8.30	11.60	V
	10336.00	-55.78	-25	-30.78	-56.66	-57.30	10.48	12.00	V

Remark: Spurious emissions within 30-1000MHz were found more than 20dB below limit line.