



Motorola Model: XT2215-1
FCC ID: IHDT56AA5

Power Density Simulation Report

December 2021
Rev. 0.1
AR-20-0001-01.0

1. Table of Contents

1.	Table of Contents	2
2.	Simulation Approach for MPE	3
2.1.	General Approach	3
2.2.	Finding Worst-Case Near-Field Results	3
2.3.	Simulation Tool	4
2.3.1.	Tool Description	4
2.3.2.	Solver Description	4
2.3.3.	Convergence criteria and power density calculations	4
2.3.4.	3D Models Used in the Simulations	6
2.3.5.	PD evaluation planes	7
2.3.6.	Boundary condition	8
2.3.7.	Source excitation condition	8
2.3.8.	Condition of simulation completion	9
2.4.	Simulated verification	10
2.4.4.1	Back Module	25
2.4.4.2	Top Module	31

2. Simulation Approach for MPE

This section details the approach taken to identify the worst-case beams and beam pairs for each mm-wave antenna array module for evaluation planes 2 mm away from the mobile device.

2.1. General Approach

The concept of beamforming adds an additional dimension to the test matrix, effectively increasing the number of the exposure test cases to be checked, by a factor equal to the number of beams that the device can form. This makes it impractical to measure every beam in every measurement plane. Because the mm-wave power density measurement is time-consuming per beam and measurement plane, it is necessary to identify a-priori the worst-case beams for each measurement condition (plane) via simulation, so that these beams can then be measured to characterize the worst-case power density of the device.

The Ansys HFSS simulation tool (HFSS 2021 R2) was used for the simulation of near-field power density for this process.

2.2. Finding Worst-Case Near-Field Results

This process consists of two parts:

1. Finding worst-case surface(s) for each beam, per antenna group and per antenna module in the middle channel of each band for determining worst-case housing influence.
2. Finding worst-case PD value for all three channels of each band for each beam and beam pair, per antenna group and per antenna module for determining the scaling factor for input power limit.

For part 1, only a few measurement planes are considered. The details of selection criteria are as described in a later section. At each x-y-z location on any of the selected measurement planes which are near to a mm-wave module, the simulated PD for each beam from that module is assessed in the middle channel of each band. The test separation distance is 2mm from the device. The worst case of all of these PD results in a worst measurement plane is then identified, and that module and beam configuration is selected for the measurement of PD on the measurement plane in question.

For part 2, only the identified worst-case surfaces are considered as the evaluation planes. At each x-y-z location on any of the selected measurement planes which are near to a mm-wave module, the simulated PD for each beam and beam pair from that module is assessed for all three channels of each band. The test separation distance is 2mm from the device. The worst cases of all these PD results for each individual beam and beam pair are then identified, and that PD value is then compared to PD design target for determining the scaling factor for input power limit as described in RF Exposure Part 0 Report.

For single beams (single-polarization beam generated by transmission from a single Antenna Group, AG0 or AG1 in a module), the PD is simulated directly from the phase weights applied by the modem. For dual beams (beam pairs, i.e. a dual-polarization beam pair generated by transmission from both Antenna Groups in a module), a conservative uncertainty factor was applied based on simulated PD recalculated for every possible group phase relationship between the two beams, to conservatively cover the worst possible combination of relative phase between the two beams (worst-case addition of the fields).

The six measurement planes are named as follows:

- S1 = front
- S2 = back
- S3 = left
- S4 = right
- S5 = top
- S6 = bottom

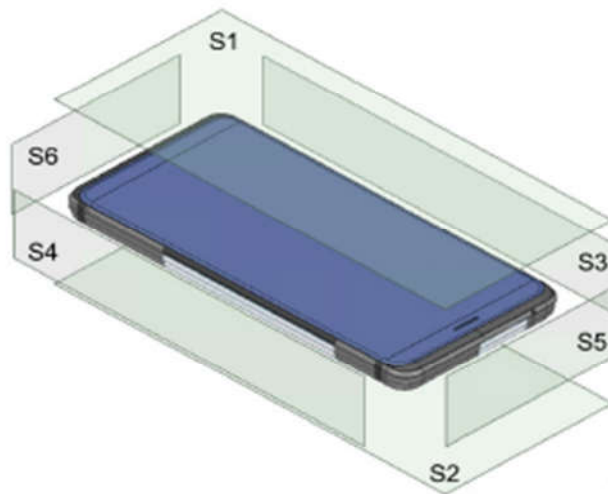


Figure 2.2-1 Identification of the six measurement planes.

2.3. Simulation Tool

2.3.1. Tool Description

For the mm-wave power density simulations, the commercially-available ANSYS Electromagnetics suite version 2021R2(HFSS) is used. The ANSYS HFSS tool is used in the industry for simulating 3D, full-wave electromagnetic fields. Motorola uses this EM simulation tool for mm-wave problems due to its established accuracy, advanced solver, and high-performance computing technology capabilities for doing accurate and rapid characterization of high-frequency components.

2.3.2. Solver Description

HFSS' solver employs the Finite Element Method, which operates in the frequency domain. The HFSS simulation employed a direct solver with first order basis functions.

2.3.3. Convergence Criteria and Power Density Calculations

HFSS uses a volume air box containing the simulated area to calculate the EM fields. The box is truncated by an Absorbing Boundary Condition. The simulation uses the adaptive mesh technique to meet the exit criteria of $\Delta S < 0.02$. The ΔS is the change in the magnitude of the S-parameters between two consecutive passes; if the magnitude and phase of all S-parameters change by an amount less than the Maximum-Delta-S-per-Pass value from one iteration to the next, the adaptive analysis stops. Otherwise, the mesh is refined in higher energy areas, according to proprietary Ansys algorithms, and an additional solution pass is taken. An example of a fully refined mesh through one cross-section of the device is shown in the figure below.

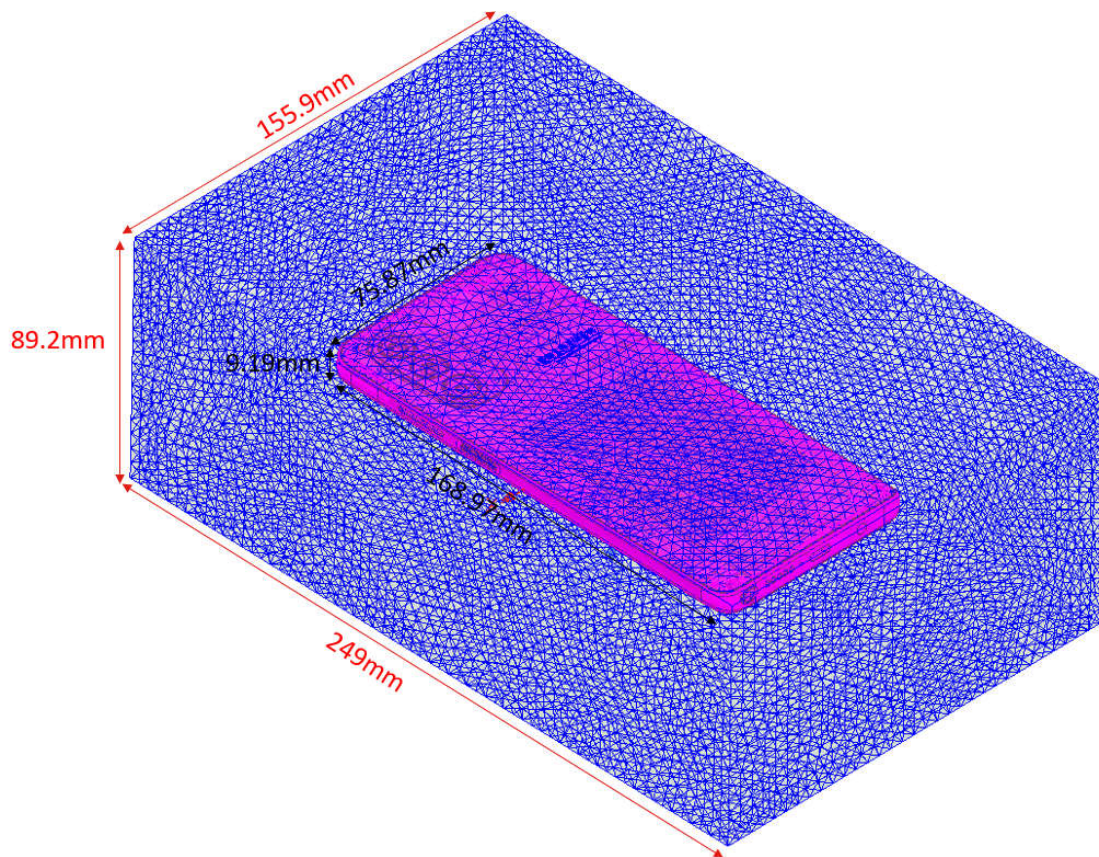


Figure 2.3.3-1: Example of the adaptive mesh technique & Mobile size

Figure 2.3.3-1: The HFSS mesh in a model of the device. After finding the simulated electric and magnetic (\vec{E} and \vec{H}) fields, the Poynting vector is calculated based on “peak” (i.e. non-RMS) field values in a grid with a 1 mm step, on the appropriate measurement planes as defined in previous sections. The Poynting vector at each spatial point is readily available in HFSS through the “Field Calculator” navigation option. The magnitude of the real part of the Poynting vector (all X, Y, Z components) at each spatial point i.e. the point power density is exported from HFSS to do the averaging. The spatially averaged power density at each point on a given surface is then calculated by taking the average of the point power density over a 4 square cm area. Thus the total power density (all X, Y, Z components) through any given surface is used to calculate the averaged power density.

Hence the spatially averaged power density on a given surface is calculated as the surface integral of the Poynting vector over a 4 square cm averaging area A :

$$P_{av} = \frac{1}{2A} \int_A |\text{Re}(\vec{E} \times \vec{H}^*)| \cdot dS$$

Note that \vec{E} and \vec{H} are the complex field vectors, and the calculation thus leads to the total power density average.

2.3.4. 3D Models Used in the Simulations

The 3D model simulated consists of the full CAD model of the mobile device that includes all of the significant structure such as PCB, metal frame, battery, cables and legacy antennas as well as mmWave antenna modules called Back module and Right module. The modeling contains the entire EUT to enable a Smart transmit GEN2 as well. Back module is placed at the back side of the device, facing the back side and Top module is placed at the top side of the device, facing the top side. A view of the 3D model variant used in each of the various module simulations is shown in the figures 2.3.4-1 to 2.3.4-2.

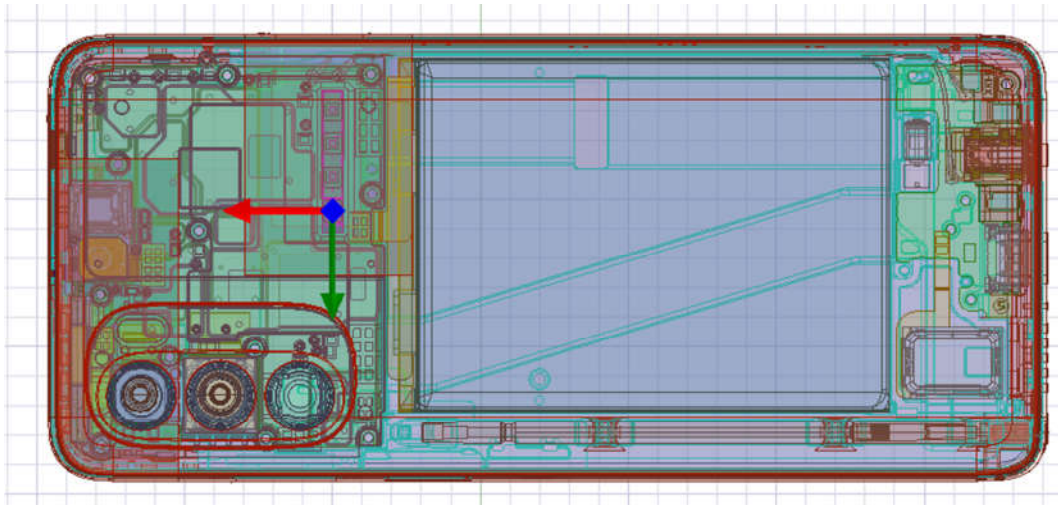


Figure 2.3.4-1: 3D model used for Module 0 (**Back module**), the antenna array is highlighted

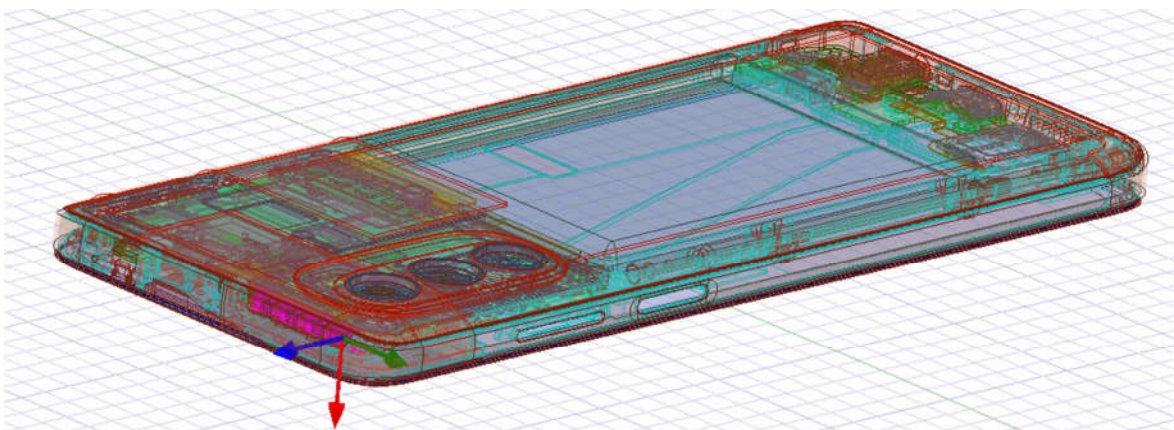


Figure 2.3.4-1: 3D model used for Module 1 (**Top module**), the antenna array is highlighted

2.3.5. PD Evaluation Planes

Due to the location of the mmWave module and the antenna array orientation relative to the surface of the device, one or more surface(s) might be excluded for PD calculation as they will have no impact for the worst-case PD determination when using Equation below:

$$PD = \max\{PD_{S1}, PD_{S2}, PD_{S3}, PD_{S4}, PD_{S5}, PD_{S6}\}$$

Where $PD_{S1}, PD_{S2}, PD_{S3}, PD_{S4}, PD_{S5}, PD_{S6}$ are the highest PD on surface S1,S2,S3,S4,S5 and S6 of the devices respectively.

Please note that the 'Right' and 'Left' edge mentioned in this report are defined from the perspective of looking at the device from the front side (display) with the top of the device pointing up.

Table 1. PD evaluation planes

	Front	Back	Left	Right	Top	Bottom
	S1	S2	S3	S4	S5	S6
Top Module	O	O	O	O	O	O
Back Module	O	O	O	O	O	O

Figure 2.3.5-1 is the PD surface(2mm&5mm). It is used to export PD data of 2mm&5mm on each surface, and then calculate PD data of 4cm² after export.

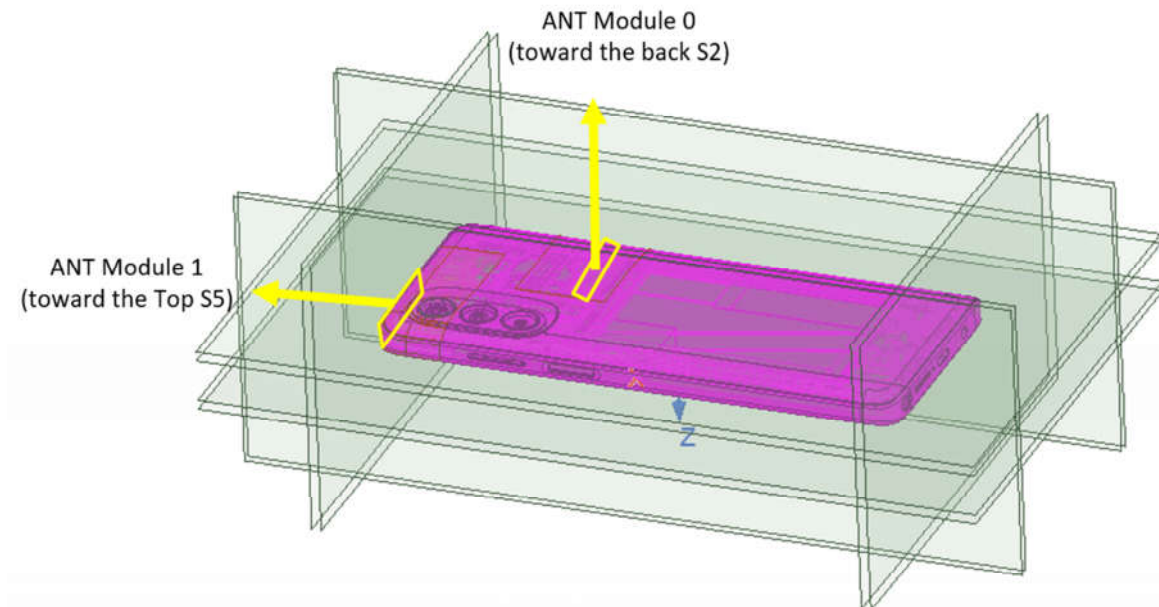


Figure 2.3.5-1: PD surface(2mm&5mm)

2.3.6. Boundary Condition

To simulate electromagnetic tool based on FEM, the boundary condition allows electromagnetic waves to be electrically open at the boundary and radiated far away without reflection. ANSYS Electromagnetics suite version 2021.R2 (HFSS) can support the absorbing boundary condition (ABC) for radiation boundary and normally make a quarter wavelength from the radiating structure. In this report, to cover all beamforming cases of mmWave antenna modules, 40 mm spacing from the device for each surfaces were adopted. This distance is sufficiently large enough for “Qualcomm MG script” to extract valid E- and H-fields from all adjacent exposure surfaces of the EUT.

2.3.7. Source Excitation Condition

The number of antenna ports of module 0 and module 1 for source excitation are the same. The antenna port of module0 and module1 is divided into 8 ports included in each patch antenna, 4 ports are divided into vertical polarization feeding, and the other 4 ports are divided into horizontal polarization feeding.

Figure 2.3.7.1 shows the module 1 structure and surrounding structure. The module 1 is encrypted in the ANSYS Electromagnetics suite (HFSS) and can only check the feeding position.

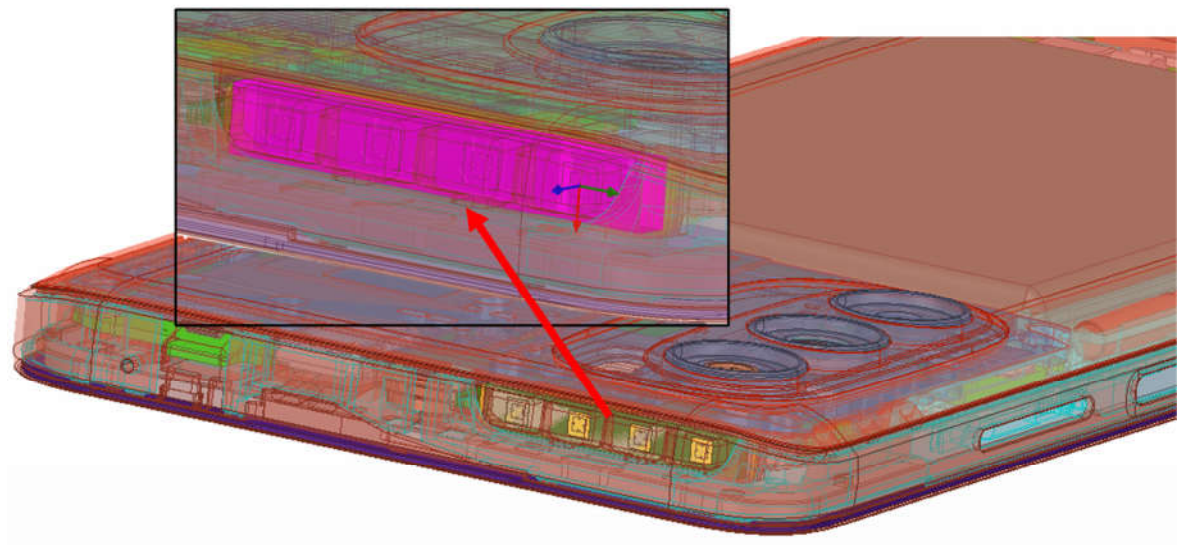


Figure 2.3.7.1 mmWave module 1

After finishing 3D full wave electromagnetic simulation of modeling structure, the magnitude and phase information can be loaded for each port by using “Edit Sources” function in ANSYS Electromagnetics suite (HFSS). Figure 2.3.7.2 shows an example of antenna port excitations.

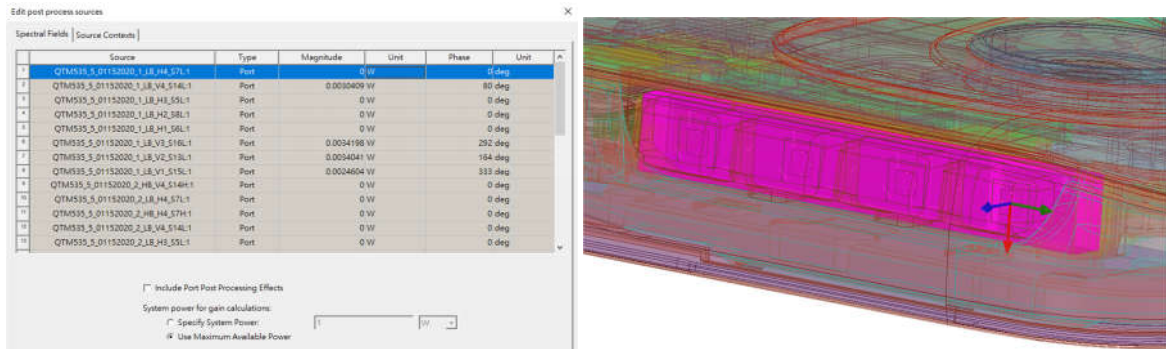


Figure 2.3.7.2 An example of port excitation (module 1)

Since ANSYS Electromagnetics suite (HFSS) uses FEM solver based on frequency domain analysis method, the input source for the port excitation applies sinusoidal waveform for each frequency.

2.3.8. Condition of Simulation Completion

The simulation completion condition of ANSYS Electromagnetics suite (HFSS) is defined as delta S. The ANSYS Electromagnetics suite (HFSS) calculates the S-parameter for the mesh conditions of each step and determines whether to proceed with the operation of the next step by comparing the difference between the S-parameters in the previous step. A difference between the previous step and the current step of S-parameter is expressed as delta S, and the delta S generally sets 0.02. The simulation result of this report is the result of setting delta S to 0.02.

2.4. Simulated Verification

2.4.1. Spatial-Averaged Power Density

As mentioned in the previous section, the Poynting vector (\vec{S}) can be obtained through cross product of an electric field (\vec{E}) and complex conjugate of a magnetic field (\vec{H}). The real term of the Poynting vector can be described as the point power density or peak power density. Using the point power density, the spatial-averaged power density can be obtained by the integral of a 4 square cm area at 1 mm intervals of the point power density result.

Figure 2.4.1-1 shows examples of the distribution plot of point power density and the averaged power density.

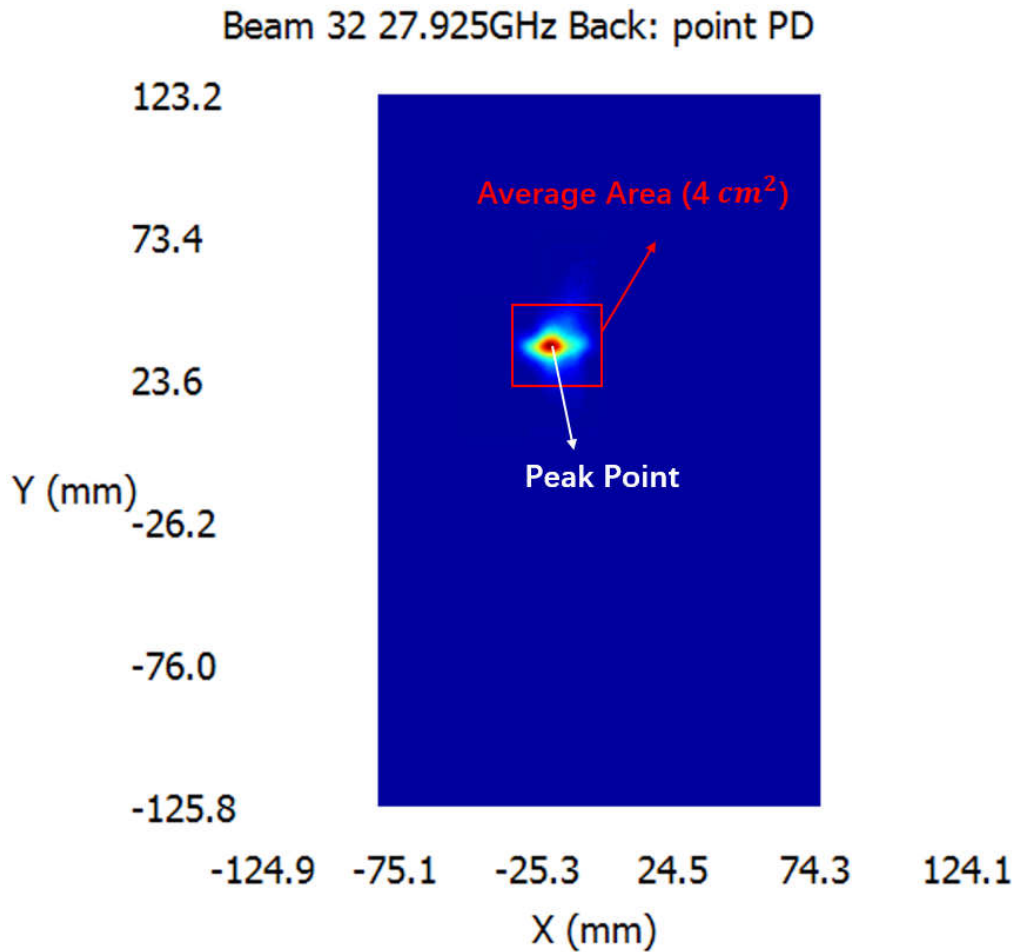


Figure 2.4.1-1 Power density distribution (Example)

For the Smart transmit GEN2, the “Qualcomm MG script” were used to extract E- and H-fields from the validated simulation and to assess the mutual coupling between all the mmWave antenna modules and all the beams in the codebook to determine the backoff value for each mmWave module. Note the assessment and backoff value derivation are automated with “Qualcomm MG script”. Once the script is done with assessment, it will provide the sim.power.limit (backoff is already included) for all the beams for all three channels for the specified PD_design_target. This mode takes the minimum sim.power.limit out of all three channels (low, mid and high) and use the result sim.power.limit

2.4.2. Simulated and Measured Results

In this section, the simulated power density distribution and measured power density distributions are compared to each mmWave antenna. Furthermore, to verify the Smart transmit GEN2, the PD distributions printing out from the “Qualcomm MG script” are added.

Based on comparison of power density distributions, the power densities of simulated, measured and the “Qualcomm MG Script” have a good correlation. The discrepancy in amplitude between the “Qualcomm MG Script” 4cm² averaged power density and measured 4cm² averaged power density is considered as housing influence and used in determining input power limit for each beam for RF exposure compliance.

The input powers per each active port are listed below for both Simulation and Measurement validation and power density characterization. For Simulation, these values were entered directly into the HFSS model. For measurements, using FTM, the phone was configured to set the active port power to these powers in CW modulation.

Table 2 Input power for simulations and measurements

Band	Antenna	Input Power (dBm)	
		SISO	MIMO
n261	Back Module	6	6
	Top Module	6	6
n260	Back Module	6	6
	Top Module	6	6

PD evaluations were performed based on simulation for all the beams on all determined surfaces of the device. The beams that correspond to the worst PD for each antenna group for each antenna module for both bands with their corresponding worst surfaces are listed in below table:

Table 3 Worst case beams for each antenna group for each antenna module identified through HFSS simulations

Band	Antenna	Beam ID	Surface
n260	Back module (patch)	36	Back (S2)
		167	Back (S2)
	Top module (patch)	24	Back (S2)
		154	Back (S2)
		24	Top (S5)
		161	Top (S5)
n261	Back module (patch)	32	Back (S2)
		159	Back (S2)
	Top module (patch)	28	Back (S2)
		155	Back (S2)
		28	Top (S5)
		146	Top (S5)

2.4.3. Comparison Between Simulated and Measured Results

The below simulation at measurement results were performed at 2mm evaluation distance and 28GHz/38.5GHz. The input power limit was determined based on the results below from the RF Exposure Part 0 Report.

Table 4 Comparison between simulated and measured results

Band	Antenna	Beam ID	Surface	Channel	4 cm ² avg. PD (W/m ²)	
					Meas.	Sim.
n261	Back module (patch)	32	Back(S2)	Mid	8.49	14.81
		159	Back(S2)	Mid	10.5	13.61
	Top module (patch)	28	Top(S5)	Mid	7.01	12.14
		146	Top(S5)	Mid	6.02	11.25
		28	Back(S2)	Mid	4.23	7.44
		146	Back(S2)	Mid	4.35	6.90
n260	Back module (patch)	36	Back(S2)	Mid	8.06	15.75
		167	Back(S2)	Mid	7.74	13.54
	Top module (patch)	24	Top(S5)	Mid	6.86	12.63
		154	Top(S5)	Mid	5.82	9.62
		24	Back(S2)	Mid	2.72	9.08
		161	Back(S2)	Mid	7.6	6.71

Based on comparison of power density distributions, simulated power density and measured power density have a good correlation. The discrepancy in amplitude between simulated 4cm² averaged power density and measured 4cm² averaged power density is considered as housing influence and used in determining input power limit for each beam for RF exposure compliance (see RF Exposure Part 0 Report).

Table 5-1 n261 module 0: Mid Channel , Beam ID 32

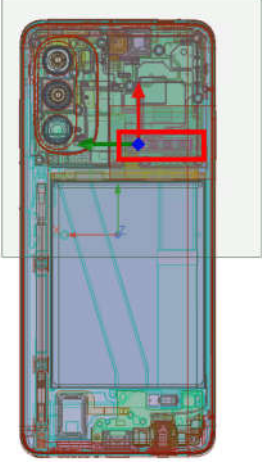
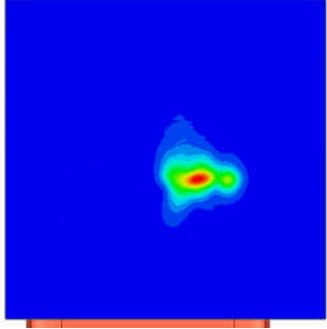
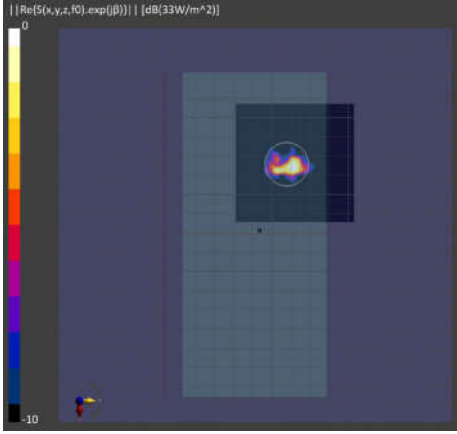
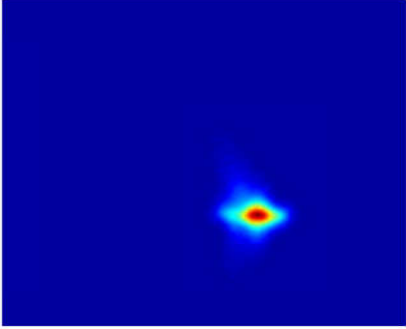
Beam ID	Surface	View	Simulated PD
32	S2(Back)		
		<p data-bbox="639 909 788 943">Measured PD</p> 	<p data-bbox="991 909 1378 943">Print out from Qualcomm MG script</p> 

Table 5-2 n261 module0: Mid Channel, Beam ID 159

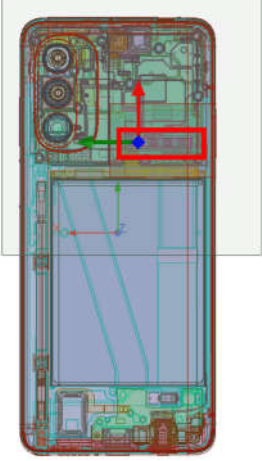
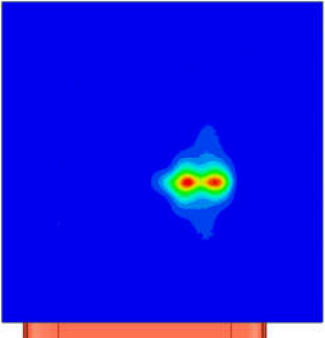
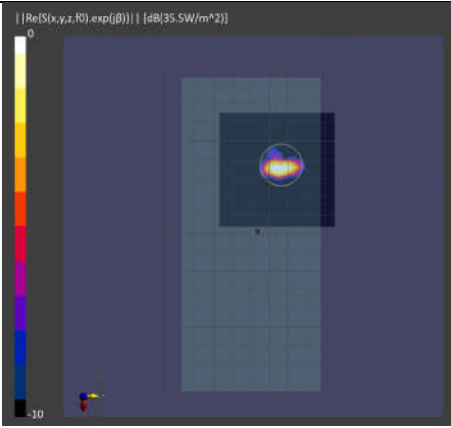
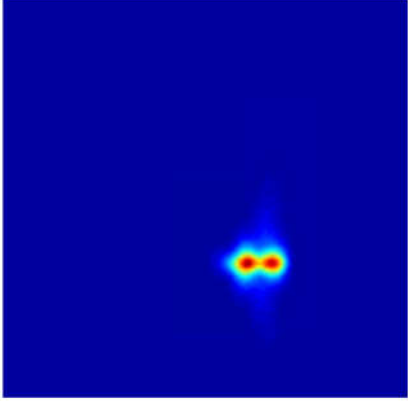
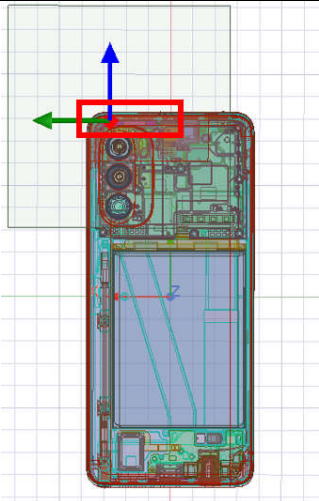
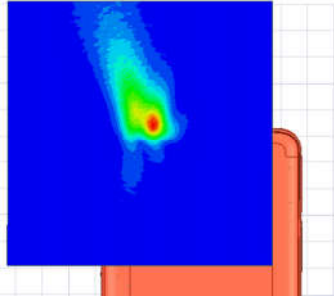
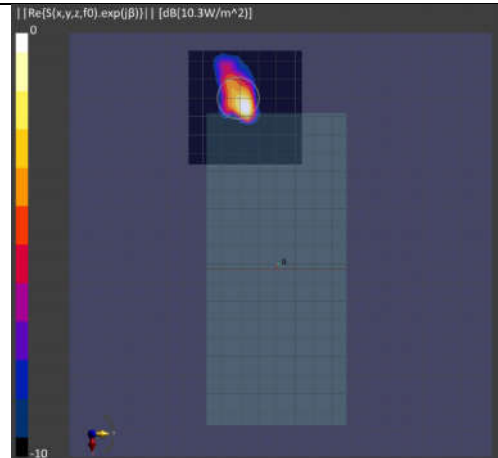
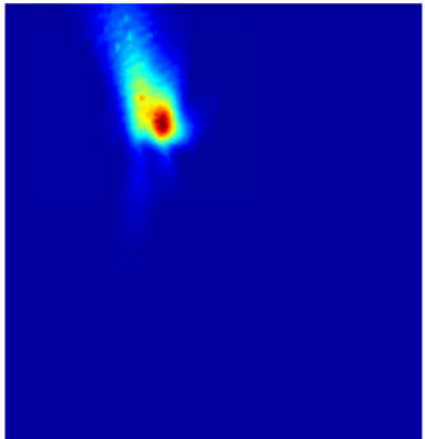
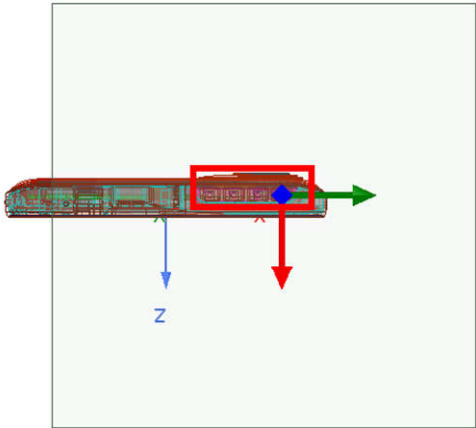
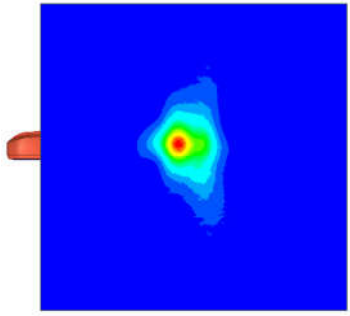
Beam ID	Surface	View	Simulated PD
159	S2(Back)		
		<p data-bbox="638 907 790 940" style="text-align: center;">Measured PD</p> 	<p data-bbox="981 907 1380 940" style="text-align: center;">Print out from Qualcomm MG script</p> 

Table 5-3 n261 module1: Mid Channel, Beam ID 28

Beam ID	Surface	View	Simulated PD
28	S2(Back)		
		<p>Measured PD</p> 	<p>Print out from Qualcomm MG script</p> 
	S5(Top)		
		<p>Measured PD</p>	<p>Print out from Qualcomm MG script</p>

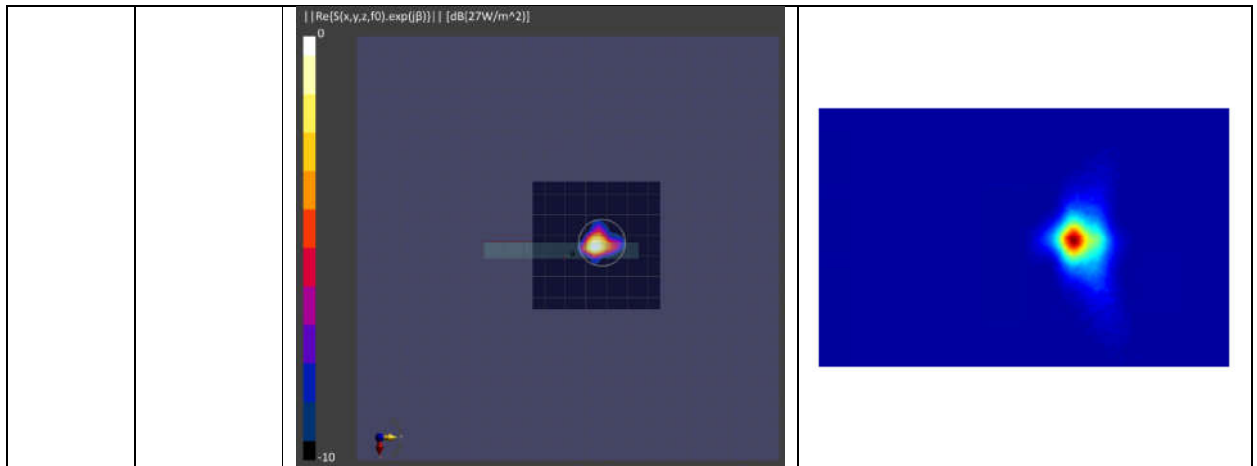


Table 5-4 n261 module1: Mid Channel, Beam ID 146

Beam ID	Surface	View	Simulated PD
146	S2(Back)		
		<p>Measured PD</p>	<p>Print out from Qualcomm MG script</p>
	S5(Top)	<p>View</p>	<p>Simulated PD</p>

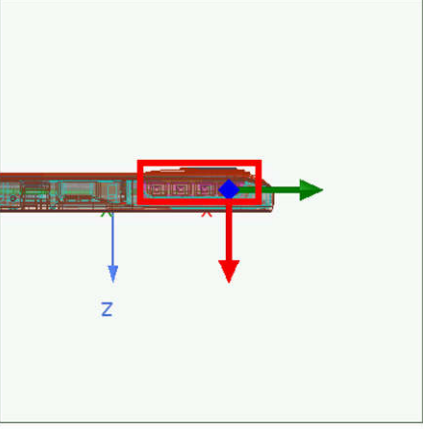
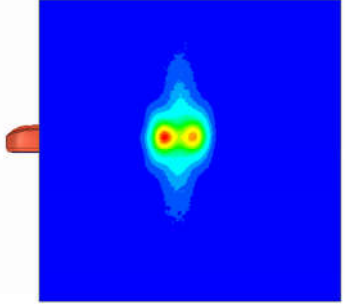
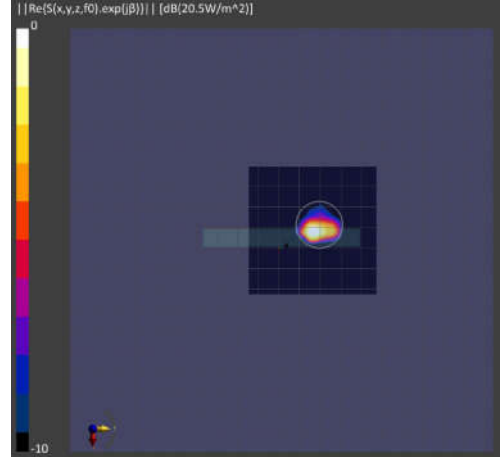
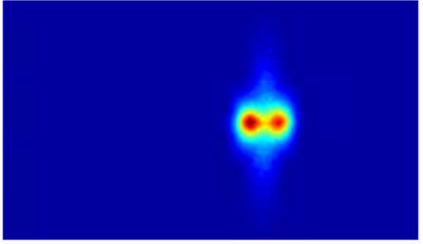
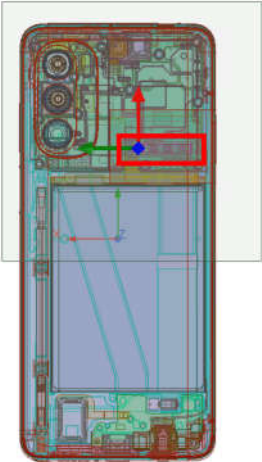
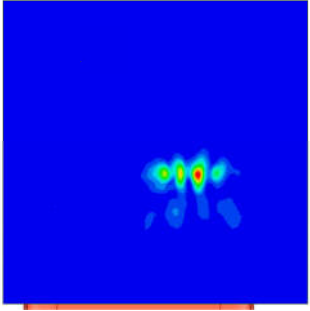
			
		Measured PD	Print out from Qualcomm MG script
			

Table 5-5 n260 module 0: Mid Channel, Beam ID 36

Beam ID	Surface	View	Simulated PD
36	S2(Back)		
		Measured PD	Print out from Qualcomm MG script

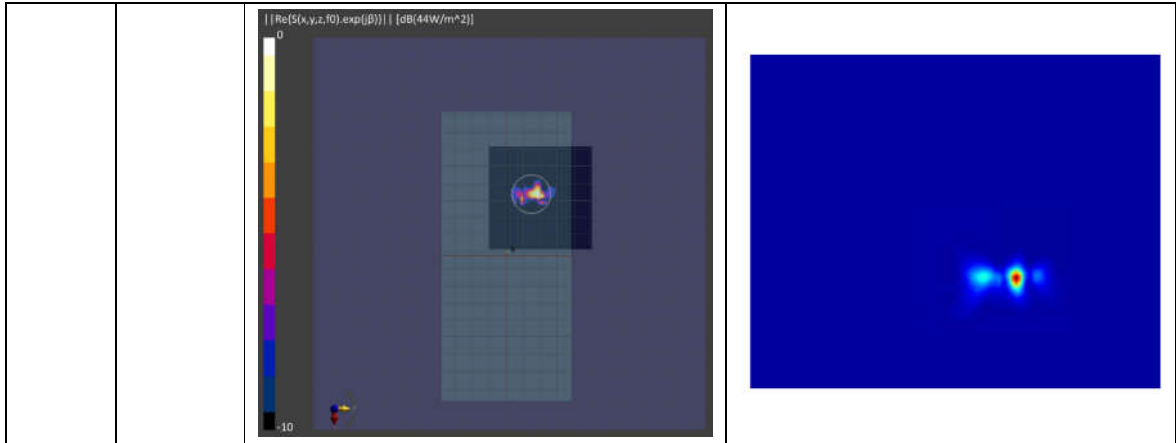
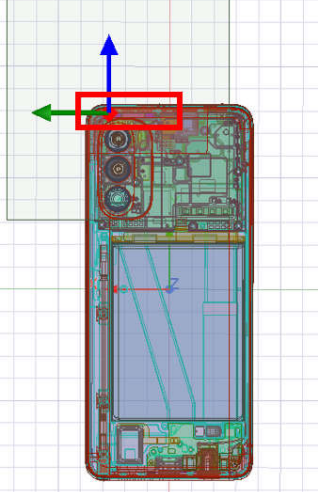
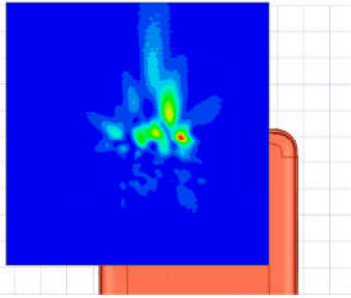
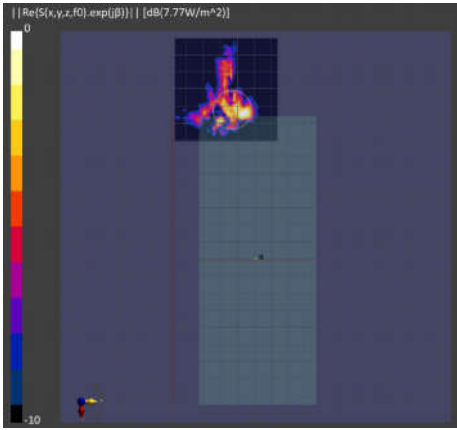
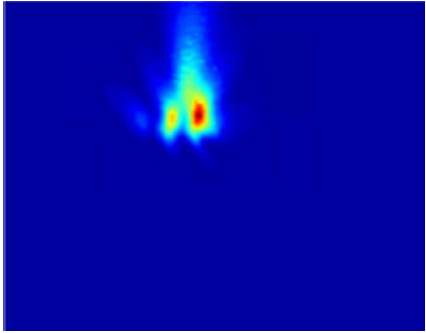
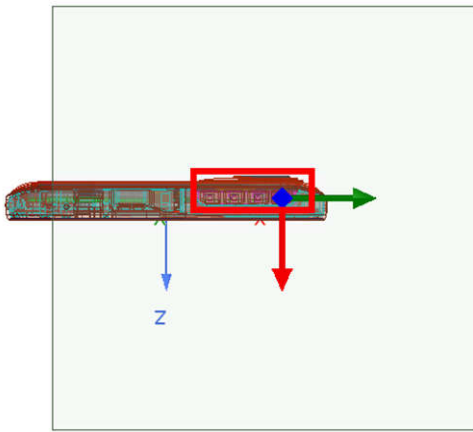
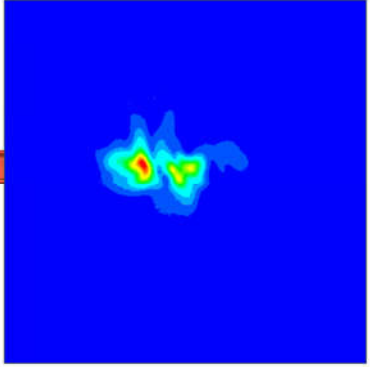


Table 5-6 n260 module 0: Mid Channel, Beam ID 167

Beam ID	Surface	View	Simulated PD
167	S2(Back)		
		<p>Measured PD</p>	<p>Print out from Qualcomm MG script</p>

Table 5-7 n260 module 1: Mid Channel, Beam ID 24

Beam ID	Surface	View	Simulated PD
24	S2(Back)		
		<p data-bbox="639 913 788 943">Measured PD</p> 	<p data-bbox="986 913 1377 943">Print out from Qualcomm MG script</p> 
	S5(Top)	<p data-bbox="671 1388 740 1417">View</p> 	<p data-bbox="1094 1388 1246 1417">Simulated PD</p> 
		<p data-bbox="628 1861 777 1890">Measured PD</p>	<p data-bbox="975 1861 1366 1890">Print out from Qualcomm MG script</p>

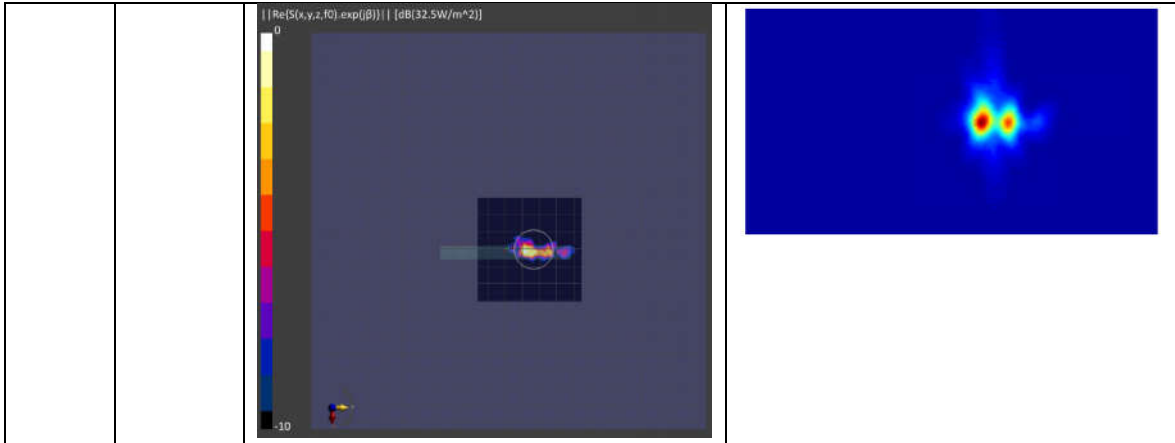
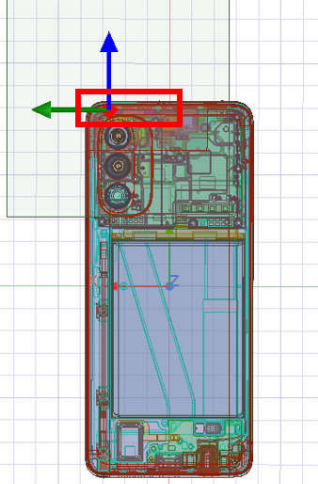
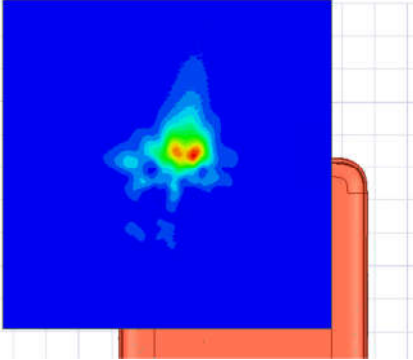
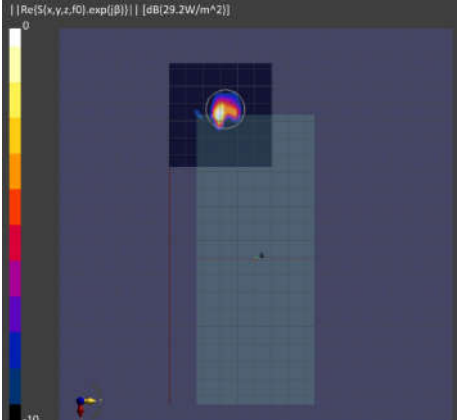
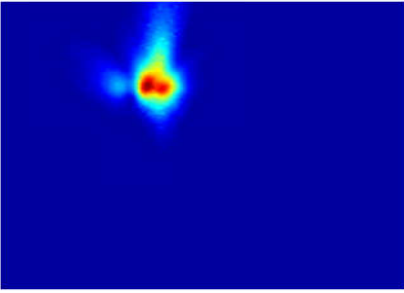


Table 5-8 n260 module 1: Mid Channel, Beam ID 154

Beam ID	Surface	View	Simulated PD
154	S5(Top)		
		<p>Measured PD</p>	<p>Print out from Qualcomm MG script</p>

Table 5-9 n260 module 1: Mid Channel, Beam ID 161

Beam ID	Surface	View	Simulated PD
161	S2(Back)		
		<p data-bbox="641 913 788 940">Measured PD</p> 	<p data-bbox="992 913 1375 940">Print out from Qualcomm MG script</p> 

The Smart transmit GEN2 cannot be finalized until the additional verification are performed and passed. Follow

The below steps for verifications in the mid channel:

VERIFICATION 1:

Use “Qualcomm MG script” to print the PD plots for all the beams selected and evaluated for model validation.

- Throughout above comparisons (Table 5-1 to 5-9), the model validation including MG script were verified.

VERIFICATION 2:

Contribution factors from Qualcomm MG script and from HFSS for selected beams, and normalized combined PD verification, for this device with 2 QTM535-5 modules. The printed contribution factor from Qualcomm MG Script was within 2% numerical tolerance of the simulated contribution factor. Additionally, the normalized combined PD is <1.0.

[N261 band]

Worst-case surface:					Top(S5)	
Worst-case location(x,y,z) in meters:					(0.00952,0.08515,-0.00362)	
PD design target(W/m2)					4.93	
Values printd from Qualcomm MG Script					Values obtained by OEM using EM simulation tool	
QTM#	Beam ID	$c(i,j)$ <i>i</i> =beam ID <i>j</i> =QTM#	Backoff factor <i>b_j</i>	<i>verification.sim.power</i> <i>limit</i> (before backoffs)[dBm]	Simulated 4cm2 PD (<i>i,j</i>) at (0.00952,0.08515,- 0.00362) <i>verification.sim.powerlimit</i> on S5	<i>csimulated(i,j)</i> = <i>4cm2PD(i,j)/PD_design_target</i>
0	32	0.0245	0.9772	1.22	$0.3622 \cdot 10^{((1.22-6)/10)}$ =0.1205	0.1205/4.93=0.02442
1	154	0.9993	0.955	4.62	$6.7721 \cdot 10^{((4.62-6)/10)}$ =4.9286	4.9286/4.93=0.9997
Verify 1: $c(i,j) = c_{simulated(i,j)}$, $i=32,154;j=0,1$						
Verify 2: $b_0 \cdot c(32,0) + b_1 \cdot c(154,1) = 0.9772 \cdot 0.0245 + 0.955 \cdot 0.9993 = 0.9782729 \leq 1$						

[N260 band]

Worst-case surface:					Top(S5)	
Worst-case location(x,y,z) in meters:					(0.00752, 0.08515, -0.00262)	
PD design target(W/m2)					4.93	
Values printd from Qualcomm MG Script					Values obtained by OEM using EM simulation tool	
QTM#	Beam ID	$c(i,j)$ <i>i</i> =beam ID <i>j</i> =QTM#	Backoff factor <i>b_j</i>	<i>verification.sim.power</i> <i>limit</i> (before backoffs)[dBm]	Simulated 4cm2 PD (<i>i,j</i>) at (0.00752, 0.08515, - 0.00262) <i>verification.sim.powerlimit</i> on S5	<i>csimulated(i,j)</i> = <i>4cm2PD(i,j)/PD_design_target</i>
0	166	0.0376	0.9772	2.64	$0.4008 \cdot 10^{((2.64-6)/10)}$ =0.1849	0.1849/4.93=0.03751
1	134	0.9989	0.9333	10.28	$1.8405 \cdot 10^{((10.28-6)/10)}$ =4.9310	4.931/4.93=1.0002
Verify 1: $c(i,j) = c_{simulated(i,j)}$, $i=166,134;j=0,1$						
Verify 2: $b_0 \cdot c(166,0) + b_1 \cdot c(134,1) = 0.9772 \cdot 0.0376 + 0.9333 \cdot 0.9989 = 0.969016 \leq 1$						

VERIFICATION 3:

Measured 4cm² PD on worst surface and combined PD at worst-case location for this device with 2 QTM535-5 modules. The device should be measured at the reference power level and scaled to the input.power.limit. The combined PD should be less than or equal to the PD_Design_Target within the uncertainty at the reference power level.

[N261 band]

QTM#	Beam ID	Dominant surface	Measured 4cm ² PD at input.power.limit on QTM dominant surface
0	32	S2(Back)	4.16
1	154	S5(Top)	5.34
combined PD at the worst-case location (x,y,z)			$c(32,0)*\text{meas.}4\text{cm}^2 \text{ PD}(32,0) + c(154,1)*\text{meas.}4\text{cm}^2 \text{ PD}(154,1) = 5.44$
PD_design_target + uncertainty at reference power level of 0.63dB			$=4.93*10^{(0.63/10)} = 5.7 \text{ W/m}^2$
<i>Verify</i>			combined PD < PD_design_target + uncertainty at reference power level

[N260 band]

QTM#	Beam ID	Dominant surface	Measured 4cm ² PD at input.power.limit on QTM dominant surface
0	166	S2(Back)	3.51
1	134	S5(Top)	2.57
combined PD at the worst-case location (x,y,z)			$c(166,0)*\text{meas.}4\text{cm}^2 \text{ PD}(166,0) + c(134,1)*\text{meas.}4\text{cm}^2 \text{ PD}(134,1) = 2.70$
PD_design_target + uncertainty at reference power level of 0.63dB			$=4.93*10^{(0.63/10)} = 5.7 \text{ W/m}^2$
<i>Verify</i>			combined PD < PD_design_target + uncertainty at reference power level

2.4.4. Simulated and Measured Results

This section shows the PD simulation results of both the back module and the right module at 28 GHz and 39 GHz for each evaluation plane specified in Table 2 at separation distance of 2mm and 5mm.

The relative phase between beam pairs is not controlled in the chipset design. Therefore, the relative phase between each beam pair was considered mathematically to identify the worst-case conditions. The below MIMO results represent the highest reported MIMO simulation results after a conservative uncertainty factor was applied based on simulated PD recalculated for every group phase relationship between the two beams sweeping from 0° to 360° at a 5° step interval. The worst-case simulated PD determined from the tables in this section were used for conservativeness in input.power.limit determination in RF Exposure Part 0 Report.

2.4.4.1 Back Module

Table 6-1 to 6-6 show the PD simulation evaluation of the back module at low, middle and high channel that 27.5GHz/27.925GHz/28.35GHz in n261 and 37GHz/38.5GHz/40GHz in n260 for the corresponding evaluation planes specified in Table 2.

Table 6-1 PD of Back module (n260) Low channel

Beam ID 1	Beam ID 2	Antenna Module	n260 module0_4cm2 Average Total PD (W/m ²)														Ratio worst surface back (5mm/2mm)
			Surface 2mm_low channel						Surface 5mm_low channel						78.55%		
			S1 front	S2 back	S3 left	S4 right	S5 top	S6 bottom	S1 front	S2 back	S3 left	S4 right	S5 top	S6 bottom			
1		0	0.19	2.66	0.18	0.07	0.06	0.01	0.13	1.75	0.15	0.06	0.05	0.01	65.79%		
3		0	0.17	4.52	0.19	0.05	0.08	0.02	0.11	3.29	0.17	0.04	0.07	0.02	72.79%		
5		0	0.2	4.12	0.68	0.12	0.08	0.03	0.15	2.48	0.57	0.11	0.07	0.03	60.19%		
7		0	0.21	4.14	0.6	0.04	0.08	0.02	0.14	2.91	0.44	0.03	0.07	0.02	70.29%		
12		0	0.5	8.74	2.28	0.14	0.13	0.04	0.34	5.21	1.8	0.13	0.12	0.04	59.61%		
13		0	0.34	7.45	0.36	0.2	0.22	0.08	0.23	5.19	0.26	0.18	0.2	0.08	69.66%		
14		0	0.32	7.37	0.36	0.18	0.13	0.04	0.23	4.83	0.29	0.16	0.12	0.04	65.54%		
15		0	0.28	6.78	0.51	0.06	0.24	0.04	0.2	4.93	0.44	0.05	0.21	0.04	72.71%		
19		0	0.38	8.8	0.67	0.28	0.08	0.03	0.29	5.33	0.55	0.25	0.07	0.03	60.57%		
20		0	0.43	8.09	1.44	0.05	0.28	0.09	0.29	5.41	1.15	0.05	0.25	0.08	66.87%		
21		0	0.38	8.16	1.49	0.25	0.06	0.02	0.26	5.07	1.17	0.23	0.05	0.02	62.13%		
27		0	0.89	13.01	3.58	0.3	0.24	0.11	0.63	8.55	2.96	0.24	0.22	0.1	65.72%		
28		0	0.59	10.3	0.51	0.38	0.29	0.1	0.39	6.59	0.42	0.35	0.27	0.1	63.98%		
29		0	0.68	13.6	0.97	0.11	0.85	0.23	0.51	10.63	0.79	0.1	0.77	0.22	78.16%		
30		0	0.81	14.71	2.5	0.65	0.26	0.07	0.58	9.81	2.04	0.57	0.23	0.07	66.69%		
31		0	0.51	13.51	0.38	0.29	0.57	0.18	0.37	9.73	0.28	0.26	0.52	0.18	72.02%		
36		0	0.7	14.16	2.5	0.5	0.26	0.08	0.52	9.81	2.03	0.44	0.23	0.07	69.28%		
37		0	0.69	14.61	0.22	0.16	0.81	0.24	0.53	11.41	0.19	0.14	0.74	0.23	78.10%		
38		0	0.94	10.57	3.89	0.11	0.38	0.08	0.64	6	3.21	0.1	0.35	0.08	56.76%		
39		0	0.78	13.18	1.56	0.82	0.2	0.05	0.55	8.48	1.23	0.74	0.19	0.05	64.34%		
	129	0	0.29	5.36	0.32	0.13	0.07	0.02	0.21	3.57	0.29	0.12	0.06	0.02	66.60%		
	131	0	0.16	5	0.32	0.02	0.07	0.01	0.11	3.69	0.25	0.02	0.07	0.01	73.80%		
	133	0	0.2	3.8	0.56	0.03	0.06	0.01	0.14	2.43	0.47	0.03	0.06	0.01	63.95%		
	135	0	0.14	2.85	0.47	0.01	0.04	0.01	0.09	2.04	0.35	0.01	0.04	0.01	71.58%		
	140	0	0.36	7.07	1.43	0.06	0.13	0.03	0.26	4.63	1.12	0.05	0.12	0.03	65.49%		
	141	0	0.46	8.13	0.36	0.03	0.23	0.05	0.35	6.26	0.26	0.03	0.21	0.04	77.00%		
	142	0	0.48	11.06	0.93	0.15	0.16	0.04	0.32	7.31	0.81	0.13	0.15	0.04	66.09%		
	143	0	0.47	11.13	0.78	0.23	0.19	0.03	0.32	7.51	0.62	0.2	0.17	0.03	67.48%		
	147	0	0.46	8.93	0.94	0.1	0.2	0.04	0.34	5.99	0.75	0.09	0.19	0.04	67.08%		
	148	0	0.38	5.75	0.95	0.02	0.18	0.03	0.28	3.99	0.77	0.01	0.16	0.03	69.39%		
	149	0	0.44	11.27	0.84	0.18	0.18	0.04	0.29	7.5	0.68	0.16	0.16	0.04	66.55%		
	155	0	0.87	14.55	4.11	0.18	0.34	0.08	0.6	9.07	3.39	0.16	0.31	0.08	62.34%		
	156	0	0.77	13.13	1.75	0.54	0.54	0.11	0.61	9.94	1.24	0.48	0.5	0.1	75.70%		
	157	0	0.82	11.33	1.7	0.16	0.62	0.15	0.62	8.34	1.46	0.14	0.57	0.14	73.61%		
	158	0	0.75	13.92	2.81	0.36	0.37	0.04	0.57	9.93	2.31	0.31	0.31	0.04	71.34%		
	159	0	0.87	13.68	1.88	0.46	0.57	0.1	0.68	9.46	1.36	0.42	0.53	0.1	69.15%		
	164	0	0.79	14.27	2.84	0.37	0.43	0.04	0.6	9.83	2.34	0.33	0.38	0.03	68.89%		
	165	0	0.66	12.82	0.26	0.12	0.66	0.16	0.52	10.07	0.21	0.1	0.61	0.15	78.55%		
	166	0	1.11	12.55	5.46	0.12	0.4	0.09	0.72	7.57	4.63	0.11	0.37	0.08	60.32%		
	167	0	0.95	15.57	2.87	0.38	0.54	0.05	0.74	9.81	2.23	0.33	0.49	0.04	63.01%		
1	129	0	0.57	8.66	0.79	0.31	0.18	0.04	0.38	5.97	0.69	0.28	0.17	0.04	68.94%		
3	131	0	0.44	9.88	0.81	0.1	0.2	0.05	0.3	7.16	0.7	0.09	0.18	0.05	72.47%		
5	133	0	0.54	8.75	1.8	0.2	0.21	0.06	0.36	5.29	1.5	0.18	0.19	0.06	60.46%		
7	135	0	0.53	7.29	1.46	0.08	0.17	0.05	0.35	5.12	1.07	0.07	0.15	0.04	70.23%		
12	140	0	1.21	17.49	5.12	0.32	0.26	0.06	0.83	11.05	4.04	0.29	0.24	0.05	63.18%		
13	141	0	0.98	16.33	0.85	0.28	0.7	0.2	0.73	12.32	0.6	0.26	0.63	0.19	75.44%		
14	142	0	1.2	19.33	1.75	0.54	0.45	0.12	0.81	13.14	1.5	0.47	0.42	0.12	67.98%		
15	143	0	0.87	18.8	1.57	0.36	0.31	0.1	0.59	13.68	1.38	0.32	0.29	0.09	72.77%		
19	147	0	1.12	18.13	2.29	0.55	0.39	0.1	0.79	11.33	1.88	0.5	0.35	0.1	62.49%		
20	148	0	1.17	14.72	3.59	0.07	0.65	0.18	0.83	9.84	2.94	0.07	0.59	0.17	66.85%		
21	149	0	1	16.54	2.79	0.67	0.29	0.08	0.72	12.28	2.26	0.6	0.26	0.08	74.24%		
27	155	0	2.72	31.14	10.65	0.55	0.85	0.31	1.91	20.83	8.76	0.45	0.77	0.3	66.89%		
28	156	0	1.85	27.34	2.6	1.37	0.96	0.32	1.4	18.94	1.8	1.26	0.87	0.31	69.28%		
29	157	0	2.1	25.92	4.16	0.34	1.98	0.5	1.6	20.12	3.51	0.31	1.81	0.48	77.62%		
30	158	0	2.7	31.41	7.28	1.6	0.65	0.19	2.01	22.63	6.01	1.42	0.59	0.17	72.05%		
31	159	0	1.42	28.32	2.67	1.12	0.84	0.23	1.02	20.42	2.03	1.03	0.76	0.22	72.10%		
36	164	0	2.48	31.14	6.78	1.39	0.74	0.19	1.79	21.28	5.58	1.23	0.65	0.17	68.34%		
37	165	0	2.18	28.81	0.61	0.4	2.08	0.57	1.66	22.25	0.51	0.36	1.9	0.55	77.23%		
38	166	0	3.18	30.85	14.28	0.32	1.09	0.31	2.1	19.08	12.07	0.27	0.99	0.3	61.85%		
39	167	0	2.3	31.25	5.6	1.86	0.93	0.15	1.78	20.38	4.45	1.68	0.86	0.14	65.22%		

Table 6-2 PD of Back module (n260) Middle channel

Beam ID 1	Beam ID 2	Antenna Module	n260 module0_4cm2 Average Total PD (W/m^2)														Ratio worst surface back (5mm/2mm)
			Surface 2mm_Mid channel						Surface 5mm_Mid channel						77.16%		
			S1 front	S2 back	S3 left	S4 right	S5 top	S6 bottom	S1 front	S2 back	S3 left	S4 right	S5 top	S6 bottom			
1		0	0.19	3.48	0.12	0.1	0.06	0.01	0.13	2.31	0.11	0.09	0.06	0.01	66.38%		
3		0	0.17	4.51	0.2	0.05	0.07	0.02	0.11	3.25	0.17	0.05	0.07	0.02	72.06%		
5		0	0.25	5.66	0.3	0.07	0.06	0.03	0.16	4.15	0.24	0.07	0.05	0.03	73.32%		
7		0	0.18	4.09	0.56	0.04	0.06	0.03	0.12	2.86	0.42	0.04	0.06	0.02	69.93%		
12		0	0.55	9.85	1.39	0.15	0.12	0.07	0.39	6.73	1.1	0.14	0.1	0.06	68.32%		
13		0	0.38	9	0.74	0.12	0.17	0.08	0.26	6.6	0.52	0.12	0.16	0.08	73.33%		
14		0	0.35	8.24	0.3	0.25	0.15	0.05	0.23	5.42	0.25	0.22	0.14	0.04	65.78%		
15		0	0.37	7.38	0.47	0.05	0.17	0.04	0.24	5.33	0.4	0.05	0.15	0.04	72.22%		
19		0	0.36	10.17	0.69	0.24	0.15	0.06	0.24	7.01	0.54	0.21	0.13	0.06	68.93%		
20		0	0.51	8.96	0.97	0.02	0.23	0.1	0.35	6.5	0.8	0.02	0.2	0.1	72.54%		
21		0	0.39	9.9	1.17	0.2	0.12	0.04	0.27	6.75	0.89	0.19	0.11	0.04	68.18%		
27		0	0.96	14.52	2.33	0.22	0.34	0.18	0.7	10.68	1.92	0.19	0.31	0.17	73.55%		
28		0	0.67	12.73	0.93	0.52	0.48	0.17	0.48	9.25	0.64	0.48	0.43	0.17	72.66%		
29		0	0.93	14.58	1.02	0.07	0.69	0.21	0.7	11.25	0.84	0.06	0.62	0.21	77.16%		
30		0	0.87	15.5	2.37	0.55	0.32	0.11	0.62	10.2	1.9	0.48	0.29	0.11	65.81%		
31		0	0.68	14.63	0.68	0.21	0.52	0.2	0.47	10.96	0.56	0.19	0.48	0.19	74.91%		
36		0	0.77	15.75	2.02	0.51	0.28	0.1	0.55	11.22	1.66	0.43	0.25	0.09	71.24%		
37		0	0.84	15.34	0.59	0.09	0.73	0.24	0.62	11.79	0.48	0.08	0.66	0.24	76.86%		
38		0	1	14	2.17	0.17	0.44	0.22	0.76	10.47	1.82	0.16	0.4	0.21	74.79%		
39		0	0.67	14.44	1.84	0.86	0.28	0.09	0.46	9.13	1.38	0.79	0.25	0.09	63.23%		
129		0	0.36	5.1	0.15	0.16	0.07	0.02	0.25	3.34	0.13	0.15	0.07	0.02	65.49%		
131		0	0.48	4.7	0.31	0.02	0.13	0.02	0.36	3.16	0.27	0.02	0.12	0.02	67.23%		
133		0	0.42	3.58	0.36	0.01	0.09	0.02	0.31	2.28	0.29	0.01	0.08	0.02	63.69%		
135		0	0.26	2.57	0.37	0.01	0.05	0.01	0.19	1.71	0.27	0.01	0.05	0.01	66.54%		
140		0	0.62	6.48	1.12	0.03	0.17	0.04	0.46	4.3	0.86	0.03	0.15	0.04	66.36%		
141		0	1.28	7.61	0.27	0.02	0.41	0.08	1.01	5.19	0.21	0.02	0.37	0.08	68.20%		
142		0	0.61	9.6	0.61	0.18	0.2	0.05	0.41	5.92	0.51	0.16	0.19	0.05	61.67%		
143		0	0.64	9.99	0.58	0.2	0.2	0.05	0.43	6.49	0.46	0.18	0.18	0.04	64.96%		
147		0	0.82	8.67	0.89	0.05	0.28	0.06	0.62	5.81	0.7	0.04	0.25	0.05	67.01%		
148		0	0.88	5.45	0.7	0.01	0.25	0.06	0.7	3.39	0.57	0.01	0.23	0.05	62.20%		
149		0	0.62	9.84	0.61	0.19	0.19	0.05	0.39	6.2	0.5	0.17	0.18	0.05	63.01%		
155		0	0.9	12.99	2.92	0.19	0.39	0.1	0.64	8.15	2.36	0.16	0.36	0.09	62.74%		
156		0	1.38	12.73	1.53	0.33	0.65	0.14	1.07	9.12	1.13	0.3	0.6	0.14	71.64%		
157		0	1.89	10.44	1.43	0.21	0.81	0.17	1.53	6.6	1.24	0.18	0.74	0.17	63.22%		
158		0	0.89	12.9	2.6	0.27	0.4	0.06	0.68	9.33	2.11	0.24	0.36	0.05	72.33%		
159		0	1.41	12.38	1.43	0.34	0.62	0.14	1.09	8.17	1.06	0.3	0.57	0.13	65.99%		
164		0	1.01	13.01	2.59	0.27	0.45	0.05	0.75	9.24	2.1	0.24	0.41	0.04	71.02%		
165		0	1.99	12.4	0.21	0.11	0.91	0.24	1.65	8.44	0.16	0.09	0.84	0.23	68.06%		
166		0	1.13	10.69	3.66	0.16	0.54	0.14	0.9	6.64	3.1	0.14	0.5	0.14	62.11%		
167		0	1.32	13.54	2.39	0.27	0.55	0.06	1.04	8.58	1.85	0.24	0.51	0.06	63.37%		
1	129	0	0.7	9.21	0.43	0.42	0.23	0.05	0.47	6.25	0.37	0.38	0.21	0.05	67.86%		
3	131	0	0.98	10.19	0.97	0.08	0.35	0.08	0.7	7.46	0.84	0.07	0.32	0.08	73.21%		
5	133	0	1.05	9.66	0.91	0.12	0.27	0.09	0.72	7	0.73	0.11	0.25	0.09	72.46%		
7	135	0	0.68	7.28	1.37	0.07	0.22	0.07	0.47	5.2	1.04	0.07	0.2	0.06	71.43%		
12	140	0	1.36	17.18	3.52	0.27	0.32	0.13	0.97	11.7	2.74	0.25	0.29	0.12	68.10%		
13	141	0	2	18.09	1.21	0.21	0.96	0.25	1.57	13.6	0.92	0.2	0.86	0.25	75.18%		
14	142	0	1.34	19.34	1.28	0.71	0.57	0.16	1.03	12.68	1.05	0.63	0.53	0.15	65.56%		
15	143	0	1.23	18.76	1.31	0.34	0.47	0.13	0.94	13.57	1.12	0.3	0.44	0.12	72.33%		
19	147	0	2	20.09	2.24	0.4	0.63	0.2	1.44	14.08	1.8	0.37	0.57	0.2	70.08%		
20	148	0	2.37	15.67	2.6	0.05	0.92	0.3	1.79	11.53	2.12	0.04	0.82	0.29	73.58%		
21	149	0	1.08	16.09	2.18	0.64	0.4	0.14	0.76	11.85	1.76	0.58	0.38	0.14	73.65%		
27	155	0	2.65	29.19	7.63	0.66	1.13	0.46	2.06	21.45	6.21	0.59	1.04	0.44	73.48%		
28	156	0	2.87	28.47	3.22	1.33	1.46	0.53	2.19	19.58	2.31	1.22	1.33	0.51	68.77%		
29	157	0	4.21	29.02	4.02	0.47	2.64	0.7	3.33	21.82	3.4	0.43	2.39	0.68	75.19%		
30	158	0	2.87	30.34	6.46	1.31	0.9	0.29	2.17	21.1	5.29	1.13	0.84	0.27	69.55%		
31	159	0	2.34	29.74	3.01	0.94	1.03	0.26	1.79	22.12	2.31	0.85	0.92	0.25	74.38%		
36	164	0	2.87	30.52	5.82	1.25	0.81	0.26	2.08	21.13	4.81	1.07	0.75	0.24	69.23%		
37	165	0	4.67	30.23	0.94	0.34	2.82	0.82	3.69	22.7	0.77	0.31	2.58	0.8	75.09%		
38	166	0	3.52	29.06	10.04	0.54	1.73	0.66	2.79	21.32	8.48	0.49	1.6	0.63	73.37%		
39	167	0	3.21	30.53	5.23	1.71	1.19	0.26	2.5	19.89	4.12	1.54	1.08	0.24	65.15%		

Table 6-3 PD of Back module (n260) High channel

Beam ID 1	Beam ID 2	Antenna Module	n260 module0_4cm2 Average Total PD (W/m^2)													Ratio worst surface back (5mm/2mm)
			Surface 2mm_High channel						Surface 5mm_High channel						76.34%	
			S1 front	S2 back	S3 left	S4 right	S5 top	S6 bottom	S1 front	S2 back	S3 left	S4 right	S5 top	S6 bottom		
1		0	0.18	3.46	0.14	0.08	0.06	0.01	0.13	2.31	0.12	0.07	0.06	0.01	66.76%	
3		0	0.17	4.06	0.29	0.06	0.04	0.02	0.12	2.71	0.25	0.05	0.04	0.02	66.75%	
5		0	0.21	4.9	0.42	0.04	0.08	0.02	0.14	3.37	0.36	0.04	0.08	0.02	68.78%	
7		0	0.14	3.67	0.4	0.07	0.06	0.02	0.1	2.52	0.29	0.06	0.05	0.02	68.66%	
12		0	0.41	9.42	1.26	0.09	0.14	0.07	0.29	6.57	0.96	0.08	0.13	0.07	69.75%	
13		0	0.3	7.29	0.54	0.2	0.21	0.04	0.22	5	0.35	0.18	0.19	0.04	68.59%	
14		0	0.31	8.08	0.41	0.2	0.15	0.04	0.23	5.14	0.34	0.18	0.14	0.04	63.61%	
15		0	0.45	7.24	0.58	0.05	0.15	0.03	0.33	4.98	0.5	0.04	0.13	0.03	68.78%	
19		0	0.29	9.27	0.91	0.18	0.18	0.05	0.21	6.27	0.68	0.16	0.16	0.05	67.64%	
20		0	0.47	6.76	1	0.07	0.16	0.06	0.31	4.98	0.83	0.07	0.14	0.05	73.67%	
21		0	0.3	9.85	1.19	0.15	0.18	0.04	0.21	6.59	0.88	0.14	0.16	0.04	66.90%	
27		0	0.81	14.77	2.06	0.23	0.39	0.2	0.61	10.91	1.68	0.21	0.36	0.19	73.87%	
28		0	0.63	12.94	0.86	0.48	0.65	0.15	0.42	9.72	0.57	0.44	0.59	0.15	75.12%	
29		0	1.28	11.03	2.13	0.19	0.43	0.1	0.94	8.04	1.8	0.17	0.39	0.09	72.89%	
30		0	0.81	14.7	2.42	0.48	0.34	0.12	0.59	9.77	1.94	0.42	0.3	0.11	66.46%	
31		0	0.75	12.25	1.16	0.29	0.3	0.09	0.53	8.71	0.93	0.27	0.28	0.09	71.10%	
36		0	0.67	14.62	1.96	0.38	0.29	0.12	0.49	10.44	1.63	0.31	0.26	0.11	71.41%	
37		0	1.07	11.01	1.48	0.24	0.4	0.1	0.79	8.01	1.25	0.22	0.36	0.09	72.75%	
38		0	0.73	14.03	2.34	0.13	0.5	0.2	0.55	10.71	1.98	0.12	0.46	0.2	76.34%	
39		0	0.55	14.12	2.26	0.66	0.41	0.09	0.4	9.45	1.63	0.59	0.37	0.09	66.93%	
	129	0	0.44	3.89	0.12	0.14	0.07	0.02	0.3	2.36	0.1	0.13	0.07	0.02	60.67%	
	131	0	0.49	3.9	0.14	0.03	0.1	0.03	0.37	2.49	0.12	0.02	0.09	0.03	63.85%	
	133	0	0.39	3.07	0.12	0.02	0.1	0.02	0.28	2.12	0.09	0.02	0.09	0.02	69.06%	
	135	0	0.3	2.15	0.16	0.01	0.06	0.01	0.22	1.49	0.11	0.01	0.05	0.01	69.30%	
	140	0	0.65	4.75	0.49	0.04	0.19	0.04	0.51	3.17	0.37	0.04	0.17	0.04	66.74%	
	141	0	1.14	7.24	0.23	0.04	0.37	0.08	0.89	4.92	0.18	0.04	0.33	0.08	67.96%	
	142	0	0.74	7.65	0.37	0.27	0.2	0.04	0.58	4.43	0.31	0.24	0.18	0.04	57.91%	
	143	0	0.77	7.49	0.33	0.25	0.17	0.05	0.52	4.29	0.28	0.23	0.15	0.05	57.28%	
	147	0	0.88	6.43	0.46	0.05	0.25	0.07	0.68	4.1	0.36	0.05	0.22	0.07	63.76%	
	148	0	0.82	5.42	0.21	0.02	0.27	0.05	0.65	3.78	0.16	0.01	0.24	0.05	69.74%	
	149	0	0.72	7.62	0.35	0.27	0.19	0.04	0.55	4.37	0.29	0.24	0.17	0.04	57.35%	
	155	0	1.32	9.28	1.01	0.18	0.46	0.12	1.01	5.33	0.8	0.15	0.42	0.11	57.44%	
	156	0	1.87	9.63	1.14	0.23	0.64	0.17	1.47	6.5	0.91	0.2	0.59	0.16	67.50%	
	157	0	1.83	11.04	0.75	0.13	0.77	0.19	1.48	7.3	0.65	0.12	0.71	0.18	66.12%	
	158	0	1.11	8.69	1.24	0.27	0.36	0.06	0.84	5.5	1.03	0.23	0.33	0.06	63.29%	
	159	0	1.73	9.82	1.05	0.3	0.57	0.15	1.34	6.39	0.83	0.27	0.51	0.14	65.07%	
	164	0	1.25	8.9	1.24	0.28	0.35	0.05	0.96	5.49	1.02	0.25	0.31	0.05	61.69%	
	165	0	1.76	12	0.24	0.08	0.9	0.2	1.45	8.4	0.16	0.08	0.82	0.19	70.00%	
	166	0	1.68	10.31	1	0.17	0.65	0.16	1.32	6.69	0.83	0.15	0.61	0.16	64.89%	
	167	0	1.59	9.87	1.23	0.3	0.43	0.07	1.25	5.92	0.97	0.26	0.39	0.07	59.98%	
1	129	0	0.75	8.42	0.34	0.37	0.21	0.04	0.51	5.28	0.29	0.33	0.19	0.04	62.71%	
3	131	0	0.82	9.2	0.78	0.14	0.24	0.08	0.58	6.3	0.68	0.13	0.22	0.08	68.48%	
5	133	0	0.72	9.37	0.79	0.07	0.3	0.06	0.51	6.67	0.66	0.06	0.26	0.06	71.18%	
7	135	0	0.6	6.86	0.64	0.08	0.22	0.05	0.41	4.99	0.46	0.07	0.19	0.05	72.74%	
12	140	0	1.29	16.16	1.86	0.15	0.47	0.15	0.96	11.79	1.42	0.14	0.42	0.14	72.96%	
13	141	0	1.91	15.41	1	0.41	0.89	0.21	1.48	11.34	0.73	0.37	0.8	0.2	73.59%	
14	142	0	1.52	17.82	1.17	0.74	0.57	0.15	1.19	11.81	0.98	0.66	0.52	0.14	66.27%	
15	143	0	1.43	16.05	1.46	0.42	0.49	0.11	0.97	10.77	1.22	0.37	0.45	0.11	67.10%	
19	147	0	1.68	17.45	1.78	0.34	0.77	0.23	1.23	11.92	1.39	0.31	0.69	0.23	68.31%	
20	148	0	1.64	15.01	1.92	0.11	0.74	0.19	1.26	11.23	1.56	0.11	0.66	0.18	74.82%	
21	149	0	1.2	14.8	1.83	0.72	0.43	0.14	0.95	9.86	1.43	0.66	0.39	0.13	66.62%	
27	155	0	3.15	27.41	4.27	0.76	1.42	0.53	2.52	20.06	3.49	0.66	1.31	0.5	73.18%	
28	156	0	3.3	24.4	3.31	1.2	1.98	0.61	2.52	17.48	2.55	1.08	1.79	0.6	71.64%	
29	157	0	3.15	27	5.22	0.59	2.16	0.52	2.51	20.38	4.45	0.53	1.96	0.5	75.48%	
30	158	0	2.93	26.03	4.8	1.1	1.12	0.33	2.34	18.01	3.92	0.98	1.07	0.31	69.19%	
31	159	0	2.95	26.21	3.15	1.15	1.21	0.22	2.35	18.68	2.43	1.06	1.09	0.2	71.27%	
36	164	0	2.83	25.02	4.3	0.91	0.96	0.31	2.13	17.2	3.58	0.81	0.91	0.29	68.75%	
37	165	0	3.09	26.75	2.13	0.47	2.03	0.53	2.42	19.19	1.84	0.42	1.86	0.51	71.74%	
38	166	0	3.79	28.72	5.66	0.45	2.13	0.65	3.03	21.78	4.76	0.4	1.96	0.64	75.84%	
39	167	0	3.34	25.82	5.01	1.61	1.35	0.31	2.6	17.91	3.99	1.43	1.23	0.29	69.36%	

Table 6-4 PD of Back module (n261) Low channel

Beam ID 1	Beam ID 2	Antenna Module	n261 module0_4cm2 Average Total PD (W/m^2)												80.45%	
			Surface 2mm_low channel						Surface 5mm_low channel							Ratio worst surface back (5mm/2mm)
			S1 front	S2 back	S3 left	S4 right	S5 top	S6 bottom	S1 front	S2 back	S3 left	S4 right	S5 top	S6 bottom		
3		0	0.21	2.59	0.1	0.05	0.05	0.01	0.15	1.85	0.08	0.05	0.05	0.01	71.43%	
4		0	0.25	4.33	0.13	0.11	0.09	0.01	0.2	2.83	0.12	0.1	0.08	0.01	65.36%	
5		0	0.21	4.24	0.45	0.03	0.08	0.01	0.17	3.12	0.33	0.03	0.07	0.01	73.58%	
9		0	0.32	6.59	0.36	0.27	0.11	0.02	0.22	4.08	0.3	0.24	0.1	0.02	61.91%	
10		0	0.56	6.63	0.08	0.08	0.25	0.04	0.47	4.9	0.07	0.07	0.23	0.03	73.91%	
11		0	0.3	6.27	0.3	0.27	0.11	0.02	0.2	3.88	0.25	0.24	0.1	0.02	61.88%	
14		0	0.33	6.14	0.26	0.25	0.14	0.02	0.24	3.87	0.21	0.22	0.13	0.02	63.03%	
15		0	0.39	6.92	0.37	0.24	0.15	0.03	0.29	4.4	0.31	0.22	0.13	0.03	63.58%	
21		0	0.65	10.31	1.67	0.75	0.28	0.02	0.46	6.94	1.33	0.68	0.26	0.02	67.31%	
22		0	0.74	13.76	2.09	0.12	0.62	0.11	0.58	10.58	1.53	0.11	0.56	0.11	76.89%	
23		0	0.89	15.48	0.19	0.07	0.89	0.14	0.81	12.12	0.12	0.06	0.83	0.13	78.29%	
24		0	1	15.52	0.42	0.44	0.58	0.09	0.81	11.71	0.35	0.39	0.54	0.09	75.45%	
25		0	0.59	8.61	1.89	0.69	0.2	0.02	0.45	5.57	1.5	0.63	0.18	0.02	64.69%	
30		0	0.65	10.34	2.58	0.41	0.29	0.03	0.46	7.7	2.03	0.36	0.25	0.03	74.47%	
31		0	0.82	14.76	0.54	0.11	0.81	0.13	0.68	11.41	0.39	0.1	0.74	0.12	77.30%	
32		0	1.02	16.05	0.3	0.15	0.83	0.12	0.92	12.53	0.23	0.13	0.76	0.11	78.07%	
33		0	0.75	12.05	1.36	0.74	0.34	0.03	0.56	8.38	1.1	0.66	0.32	0.03	69.54%	
	131	0	0.19	3.55	0.17	0.05	0.06	0.01	0.13	2.46	0.15	0.04	0.05	0.01	69.30%	
	132	0	0.11	4.22	0.15	0.07	0.06	0.01	0.08	3	0.12	0.06	0.05	0.01	71.09%	
	133	0	0.08	2.95	0.26	0.04	0.05	0.01	0.06	2.13	0.19	0.04	0.04	0.01	72.20%	
	137	0	0.37	7.3	0.6	0.21	0.16	0.03	0.25	4.52	0.52	0.19	0.15	0.03	61.92%	
	138	0	0.23	7.43	0.14	0.02	0.21	0.05	0.16	5.9	0.11	0.02	0.19	0.04	79.41%	
	139	0	0.25	5.61	0.88	0.16	0.1	0.01	0.18	3.45	0.66	0.15	0.09	0.01	61.50%	
	142	0	0.38	7.64	0.33	0.16	0.17	0.04	0.26	5.27	0.25	0.14	0.15	0.04	68.98%	
	143	0	0.37	7.32	0.61	0.18	0.17	0.03	0.26	4.68	0.53	0.16	0.16	0.03	63.93%	
	149	0	0.83	10.53	2.63	0.68	0.32	0.03	0.58	7.29	2.16	0.61	0.3	0.03	69.23%	
	150	0	0.48	13.27	1.63	0.03	0.58	0.12	0.37	10.39	1.17	0.02	0.53	0.11	78.30%	
	151	0	0.41	13.91	0.15	0.01	0.68	0.14	0.32	11.19	0.12	0.01	0.62	0.13	80.45%	
	152	0	0.81	12.55	0.61	0.32	0.48	0.1	0.61	9.31	0.52	0.3	0.44	0.1	74.18%	
	153	0	0.67	9.28	2.18	0.71	0.19	0.02	0.46	5.82	1.75	0.65	0.18	0.02	62.72%	
	158	0	0.66	9.57	2.08	0.49	0.28	0.02	0.44	6.84	1.65	0.45	0.25	0.02	71.47%	
	159	0	0.38	13.93	0.32	0.06	0.63	0.13	0.3	11.12	0.25	0.06	0.57	0.12	79.83%	
	160	0	0.52	13.25	0.29	0.08	0.59	0.12	0.4	10.5	0.23	0.06	0.54	0.12	79.25%	
	161	0	0.79	10.61	2.34	0.73	0.3	0.02	0.55	7.15	1.93	0.66	0.28	0.02	67.39%	
3	131	0	0.43	7.33	0.5	0.18	0.14	0.02	0.29	5.19	0.43	0.16	0.12	0.02	70.80%	
4	132	0	0.43	8.98	0.43	0.21	0.18	0.04	0.34	6.1	0.36	0.19	0.16	0.04	67.93%	
5	133	0	0.36	7.74	0.95	0.1	0.16	0.03	0.26	5.52	0.69	0.09	0.14	0.03	71.32%	
9	137	0	0.97	15.64	1.71	0.71	0.31	0.07	0.65	9.73	1.44	0.64	0.29	0.07	62.21%	
10	138	0	0.9	15.02	0.32	0.12	0.53	0.1	0.74	11.66	0.25	0.11	0.49	0.09	77.63%	
11	139	0	0.68	10.75	1.95	0.57	0.25	0.03	0.47	7	1.53	0.54	0.24	0.03	65.12%	
14	142	0	0.84	14.91	0.82	0.51	0.36	0.07	0.59	9.85	0.67	0.47	0.33	0.07	66.06%	
15	143	0	1.05	16.33	1.72	0.65	0.37	0.08	0.74	10.55	1.45	0.58	0.34	0.08	64.61%	
21	149	0	2.1	28.01	7.22	2.13	0.77	0.07	1.44	18.8	5.9	1.92	0.7	0.06	67.12%	
22	150	0	1.63	29.87	4.57	0.17	1.47	0.25	1.18	23.06	3.45	0.15	1.34	0.24	77.20%	
23	151	0	1.47	30.79	0.4	0.1	1.81	0.31	1.21	24.28	0.29	0.09	1.66	0.29	78.86%	
24	152	0	2.27	31.5	1.68	0.95	1.32	0.21	1.75	23.46	1.4	0.87	1.21	0.21	74.48%	
25	153	0	1.93	24.31	6.76	2.04	0.55	0.07	1.31	15.47	5.44	1.87	0.5	0.07	63.64%	
30	158	0	1.61	26.59	6.77	1.4	0.71	0.08	1.2	19.17	5.38	1.28	0.6	0.08	72.09%	
31	159	0	1.3	29.95	0.97	0.23	1.58	0.28	1.02	23.49	0.75	0.22	1.42	0.26	78.43%	
32	160	0	1.76	31.02	0.94	0.26	1.67	0.29	1.44	24.32	0.75	0.21	1.52	0.28	78.40%	
33	161	0	2.26	29.75	6.27	2.17	0.84	0.06	1.57	20	5.17	1.95	0.77	0.06	67.23%	

Table 6-5 PD of Back module (n261) Middle channel

Beam ID 1	Beam ID 2	Antenna Module	n261 module0_4cm2 Average Total PD (W/m^2)														Ratio worst surface back (5mm/2mm)
			Surface 2mm_Mid channel						Surface 5mm_Mid channel						80.24%		
			S1 front	S2 back	S3 left	S4 right	S5 top	S6 bottom	S1 front	S2 back	S3 left	S4 right	S5 top	S6 bottom			
3		0	0.18	2.54	0.12	0.07	0.05	0	0.13	1.81	0.1	0.06	0.05	0	71.26%		
4		0	0.2	3.92	0.14	0.08	0.07	0.01	0.17	2.62	0.12	0.07	0.07	0.01	66.84%		
5		0	0.19	3.99	0.41	0.03	0.07	0.01	0.16	2.92	0.3	0.03	0.06	0.01	73.18%		
9		0	0.32	6.35	0.43	0.25	0.11	0.02	0.23	3.93	0.35	0.22	0.1	0.02	61.89%		
10		0	0.44	5.87	0.08	0.07	0.22	0.03	0.37	4.32	0.07	0.06	0.2	0.03	73.59%		
11		0	0.29	5.99	0.36	0.24	0.1	0.01	0.21	3.67	0.3	0.22	0.09	0.01	61.27%		
14		0	0.28	5.79	0.3	0.22	0.12	0.02	0.19	3.6	0.25	0.2	0.11	0.02	62.18%		
15		0	0.38	6.65	0.43	0.23	0.15	0.02	0.29	4.23	0.35	0.2	0.13	0.02	63.61%		
21		0	0.71	10.06	1.64	0.71	0.28	0.02	0.51	6.79	1.31	0.63	0.26	0.02	67.50%		
22		0	0.76	12.84	2.01	0.1	0.55	0.11	0.6	9.82	1.51	0.09	0.5	0.1	76.48%		
23		0	0.75	14.07	0.11	0.06	0.79	0.13	0.69	11.02	0.08	0.06	0.74	0.12	78.32%		
24		0	0.97	14.62	0.4	0.41	0.57	0.08	0.8	11.1	0.34	0.37	0.53	0.08	75.92%		
25		0	0.6	8.44	1.85	0.65	0.21	0.02	0.42	5.42	1.48	0.59	0.19	0.02	64.22%		
30		0	0.76	10.13	2.55	0.42	0.28	0.03	0.53	7.48	2.02	0.37	0.25	0.03	73.84%		
31		0	0.73	13.68	0.51	0.11	0.71	0.12	0.62	10.63	0.34	0.11	0.65	0.11	77.70%		
32		0	0.89	14.81	0.3	0.14	0.78	0.11	0.81	11.57	0.24	0.11	0.71	0.11	78.12%		
33		0	0.79	11.67	1.33	0.69	0.34	0.03	0.59	8.22	1.08	0.61	0.32	0.03	70.44%		
	131	0	0.16	3.08	0.15	0.04	0.05	0.01	0.11	2.13	0.13	0.04	0.05	0.01	69.16%		
	132	0	0.11	4.2	0.14	0.07	0.06	0.01	0.08	2.98	0.11	0.06	0.06	0.01	70.95%		
	133	0	0.09	2.94	0.26	0.03	0.05	0.01	0.06	2.12	0.19	0.03	0.04	0.01	72.11%		
	137	0	0.35	6.86	0.54	0.19	0.15	0.03	0.25	4.25	0.46	0.17	0.14	0.03	61.95%		
	138	0	0.25	6.99	0.12	0.02	0.2	0.04	0.17	5.54	0.09	0.02	0.18	0.04	79.26%		
	139	0	0.25	5.6	0.9	0.15	0.1	0.01	0.18	3.45	0.67	0.14	0.09	0.01	61.61%		
	142	0	0.37	7.16	0.32	0.16	0.17	0.03	0.25	4.91	0.24	0.14	0.15	0.03	68.58%		
	143	0	0.36	6.85	0.55	0.16	0.16	0.03	0.25	4.39	0.47	0.15	0.15	0.03	64.09%		
	149	0	0.8	9.79	2.57	0.61	0.3	0.03	0.57	6.82	2.1	0.54	0.28	0.03	69.66%		
	150	0	0.53	13.03	1.57	0.03	0.59	0.11	0.41	10.17	1.15	0.03	0.53	0.11	78.05%		
	151	0	0.45	13.46	0.15	0.01	0.69	0.13	0.35	10.8	0.12	0.01	0.63	0.12	80.24%		
	152	0	0.8	11.78	0.63	0.3	0.48	0.09	0.62	8.79	0.54	0.28	0.43	0.09	74.62%		
	153	0	0.62	8.89	2.1	0.68	0.19	0.02	0.41	5.64	1.68	0.62	0.18	0.02	63.44%		
	158	0	0.61	9.22	1.95	0.5	0.28	0.02	0.41	6.57	1.55	0.45	0.24	0.02	71.26%		
	159	0	0.42	13.61	0.33	0.06	0.64	0.12	0.33	10.87	0.26	0.05	0.58	0.11	79.87%		
	160	0	0.54	12.84	0.24	0.07	0.61	0.11	0.43	10.16	0.19	0.06	0.55	0.11	79.13%		
	161	0	0.76	9.98	2.3	0.67	0.28	0.03	0.54	6.79	1.9	0.6	0.26	0.02	68.04%		
3	131	0	0.41	7.04	0.52	0.19	0.13	0.02	0.27	4.95	0.44	0.17	0.12	0.02	70.31%		
4	132	0	0.36	8.48	0.47	0.2	0.17	0.04	0.29	5.74	0.38	0.18	0.16	0.03	67.69%		
5	133	0	0.35	7.34	0.92	0.1	0.16	0.03	0.25	5.19	0.67	0.09	0.14	0.03	70.71%		
9	137	0	0.93	15.74	1.76	0.71	0.31	0.07	0.67	9.74	1.48	0.64	0.29	0.07	61.88%		
10	138	0	0.76	13.86	0.31	0.11	0.52	0.08	0.6	10.77	0.24	0.1	0.48	0.08	77.71%		
11	139	0	0.62	10.65	2.09	0.58	0.28	0.03	0.43	6.85	1.65	0.53	0.26	0.03	64.32%		
14	142	0	0.82	14.77	0.87	0.53	0.37	0.06	0.54	9.6	0.7	0.49	0.34	0.06	65.00%		
15	143	0	0.99	16.32	1.76	0.66	0.38	0.08	0.7	10.5	1.48	0.58	0.34	0.07	64.34%		
21	149	0	2.08	28.7	7.32	2.14	0.81	0.06	1.46	19.23	5.96	1.92	0.74	0.06	67.00%		
22	150	0	1.82	28.96	4.53	0.16	1.53	0.26	1.29	22.14	3.5	0.14	1.39	0.25	76.45%		
23	151	0	1.68	28.52	0.45	0.1	1.88	0.31	1.28	22.55	0.34	0.09	1.74	0.29	79.07%		
24	152	0	2.22	30.65	1.75	0.94	1.4	0.21	1.7	22.93	1.45	0.87	1.26	0.21	74.81%		
25	153	0	1.98	25.2	6.8	2.15	0.62	0.06	1.28	16.12	5.46	1.95	0.56	0.06	63.97%		
30	158	0	1.82	26.49	6.72	1.55	0.78	0.08	1.26	19.08	5.38	1.41	0.66	0.07	72.03%		
31	159	0	1.5	28.67	1.03	0.24	1.68	0.28	1.14	22.07	0.82	0.23	1.53	0.27	76.98%		
32	160	0	1.89	29.67	0.9	0.24	1.76	0.29	1.41	23.13	0.72	0.2	1.61	0.28	77.96%		
33	161	0	2.22	30.33	6.37	2.18	0.88	0.06	1.58	20.51	5.23	1.94	0.81	0.06	67.62%		

Table 6-6 PD of Back module (n261) High channel

Beam ID 1	Beam ID 2	Antenna Module	n261 module0_4cm2 Average Total PD (W/m^2)														80.37%
			Surface 2mm_High channel						Surface 5mm_High channel						Ratio worst surface back (5mm/2mm)		
			S1 front	S2 back	S3 left	S4 right	S5 top	S6 bottom	S1 front	S2 back	S3 left	S4 right	S5 top	S6 bottom			
3		0	0.14	2.42	0.13	0.08	0.05	0	0.1	1.73	0.11	0.07	0.04	0	71.49%		
4		0	0.18	3.7	0.16	0.05	0.06	0.01	0.16	2.61	0.13	0.05	0.06	0.01	70.54%		
5		0	0.17	3.62	0.36	0.03	0.06	0.01	0.14	2.65	0.26	0.03	0.06	0.01	73.20%		
9		0	0.32	6	0.4	0.23	0.1	0.02	0.23	3.75	0.33	0.21	0.09	0.01	62.50%		
10		0	0.32	5.64	0.07	0.04	0.19	0.02	0.28	4.27	0.05	0.04	0.17	0.02	75.71%		
11		0	0.28	5.72	0.34	0.21	0.1	0.02	0.2	3.55	0.29	0.19	0.09	0.01	62.06%		
14		0	0.25	5.58	0.3	0.18	0.12	0.02	0.18	3.53	0.24	0.17	0.1	0.02	63.26%		
15		0	0.37	6.29	0.39	0.22	0.13	0.02	0.29	4.04	0.32	0.19	0.12	0.02	64.23%		
21		0	0.75	9.71	1.5	0.67	0.27	0.02	0.54	6.64	1.2	0.59	0.25	0.02	68.38%		
22		0	0.73	12.13	1.91	0.06	0.53	0.1	0.58	9.28	1.43	0.06	0.48	0.1	76.50%		
23		0	0.64	12.93	0.14	0.04	0.71	0.12	0.6	10.11	0.1	0.04	0.67	0.11	78.19%		
24		0	0.85	13.46	0.42	0.38	0.53	0.07	0.71	10.27	0.35	0.35	0.5	0.07	76.30%		
25		0	0.66	8.22	1.7	0.6	0.2	0.02	0.46	5.31	1.37	0.54	0.18	0.02	64.60%		
30		0	0.7	9.56	2.36	0.4	0.29	0.03	0.49	7.07	1.87	0.36	0.25	0.03	73.95%		
31		0	0.65	12.76	0.42	0.08	0.66	0.11	0.57	9.97	0.29	0.08	0.61	0.1	78.13%		
32		0	0.76	13.57	0.24	0.12	0.71	0.11	0.7	10.6	0.19	0.1	0.65	0.1	78.11%		
33		0	0.8	11.13	1.21	0.64	0.32	0.03	0.6	7.93	0.97	0.56	0.3	0.03	71.25%		
	131	0	0.13	2.51	0.11	0.04	0.04	0.01	0.09	1.73	0.1	0.04	0.04	0.01	68.92%		
	132	0	0.11	3.73	0.13	0.06	0.06	0.01	0.08	2.62	0.11	0.05	0.06	0.01	70.24%		
	133	0	0.09	2.69	0.25	0.03	0.05	0.01	0.06	1.92	0.18	0.02	0.04	0.01	71.38%		
	137	0	0.32	5.98	0.45	0.17	0.14	0.03	0.22	3.72	0.39	0.15	0.13	0.03	62.21%		
	138	0	0.24	5.92	0.11	0.02	0.19	0.03	0.17	4.65	0.09	0.02	0.17	0.03	78.55%		
	139	0	0.23	5.16	0.87	0.12	0.09	0.01	0.17	3.15	0.66	0.11	0.08	0.01	61.05%		
	142	0	0.3	6.14	0.27	0.15	0.14	0.03	0.2	4.14	0.21	0.14	0.13	0.03	67.43%		
	143	0	0.32	5.94	0.46	0.14	0.15	0.03	0.23	3.82	0.4	0.12	0.14	0.03	64.31%		
	149	0	0.72	8.42	2.37	0.49	0.27	0.03	0.52	5.8	1.94	0.44	0.25	0.03	68.88%		
	150	0	0.52	11.3	1.36	0.04	0.52	0.1	0.41	8.78	1	0.04	0.48	0.09	77.70%		
	151	0	0.5	11.82	0.14	0.01	0.65	0.11	0.39	9.5	0.11	0.01	0.6	0.1	80.37%		
	152	0	0.75	10.2	0.6	0.27	0.45	0.08	0.58	7.64	0.51	0.25	0.41	0.08	74.90%		
	153	0	0.57	7.8	1.93	0.6	0.18	0.01	0.37	4.98	1.55	0.54	0.16	0.01	63.85%		
	158	0	0.48	8.08	1.71	0.45	0.24	0.02	0.35	5.8	1.36	0.41	0.21	0.02	71.78%		
	159	0	0.45	12.06	0.31	0.05	0.61	0.1	0.36	9.64	0.25	0.05	0.55	0.1	79.93%		
	160	0	0.57	11.43	0.2	0.06	0.58	0.1	0.45	9.01	0.16	0.05	0.53	0.09	78.83%		
	161	0	0.69	8.73	2.12	0.56	0.26	0.02	0.49	5.95	1.74	0.5	0.24	0.02	68.16%		
3	131	0	0.36	6.62	0.47	0.2	0.12	0.02	0.26	4.64	0.4	0.18	0.11	0.02	70.09%		
4	132	0	0.36	8.33	0.42	0.18	0.17	0.03	0.29	5.77	0.33	0.16	0.16	0.03	69.27%		
5	133	0	0.34	6.94	0.85	0.09	0.15	0.03	0.24	4.97	0.62	0.09	0.14	0.02	71.61%		
9	137	0	0.88	15.47	1.58	0.68	0.31	0.07	0.62	9.6	1.33	0.6	0.28	0.06	62.06%		
10	138	0	0.72	13.03	0.3	0.08	0.5	0.07	0.51	10.06	0.23	0.07	0.47	0.06	77.21%		
11	139	0	0.61	9.89	2.01	0.52	0.27	0.03	0.42	6.36	1.61	0.48	0.25	0.03	64.31%		
14	142	0	0.8	14.36	0.86	0.52	0.37	0.05	0.52	9.31	0.7	0.48	0.33	0.05	64.83%		
15	143	0	0.94	15.91	1.58	0.62	0.37	0.07	0.68	10.27	1.33	0.55	0.33	0.07	64.55%		
21	149	0	2.06	27.43	6.68	1.99	0.79	0.05	1.49	18.49	5.43	1.77	0.72	0.05	67.41%		
22	150	0	1.85	27.77	4.3	0.14	1.53	0.25	1.36	21.15	3.34	0.13	1.39	0.24	76.16%		
23	151	0	1.83	27.32	0.48	0.07	1.88	0.3	1.42	21.5	0.37	0.07	1.76	0.27	78.70%		
24	152	0	2.16	29.18	1.79	0.89	1.4	0.21	1.62	21.91	1.47	0.83	1.27	0.2	75.09%		
25	153	0	2.04	24.54	6.15	2.07	0.62	0.05	1.35	15.8	4.94	1.86	0.56	0.05	64.38%		
30	158	0	1.78	24.55	6.04	1.53	0.79	0.08	1.22	17.8	4.85	1.38	0.68	0.07	72.51%		
31	159	0	1.65	27.67	1.02	0.22	1.74	0.27	1.28	21.46	0.81	0.2	1.59	0.26	77.56%		
32	160	0	1.99	28.59	0.73	0.22	1.78	0.27	1.51	22.2	0.59	0.18	1.64	0.26	77.65%		
33	161	0	2.18	29.38	5.89	2.05	0.87	0.07	1.59	20.09	4.83	1.82	0.8	0.06	68.38%		

2.4.4.2 Top Module

Table 7-1 to 7-6 show the PD simulation evaluation of the Top module at low, middle and high channel that 27.5GHz/27.925GHz/28.35GHz in n261 and 37GHz/38.5GHz/40GHz in n260

Table 7-1 PD of Top module (n260) Low channel

Beam ID 1	Beam ID 2	Antenna Module	n260 module1_4cm2 Average Total PD (W/m^2)												81.97%	Ratio worst surface back or top (5mm/2mm)
			Surface 2mm_low channel						Surface 5mm_low channel							
			S1 front	S2 back	S3 left	S4 right	S5 top	S6 bottom	S1 front	S2 back	S3 left	S4 right	S5 top	S6 bottom		
0		1	0.86	1.3	0.05	0.8	1.87	0	0.59	0.69	0.04	0.58	1.29	0	68.98%	
2		1	1.27	2.31	0.05	0.62	3.52	0	0.82	1.49	0.04	0.46	2.59	0	73.58%	
4		1	0.89	2	0.13	0.55	2.65	0	0.61	1.17	0.12	0.46	1.79	0	67.55%	
6		1	1.27	2.08	0.06	0.14	3.14	0	0.85	1.34	0.06	0.12	2.29	0	72.93%	
8		1	1.67	3.72	0.21	1.97	5.63	0	1.11	2.41	0.19	1.57	3.61	0	64.12%	
9		1	2.12	3.46	0.06	0.86	4.8	0	1.52	2.31	0.06	0.71	3.7	0	77.08%	
10		1	2.48	4.13	0.29	0.25	6.08	0.01	1.77	2.43	0.26	0.21	4.15	0.01	68.26%	
11		1	1.46	3.73	0.07	1.76	5.06	0	1	2.19	0.06	1.35	3.35	0	66.21%	
16		1	1.47	3.85	0.22	1.06	5.36	0	0.98	2.1	0.2	0.9	3.23	0	60.26%	
17		1	2.64	3.9	0.1	0.64	5.57	0.01	1.95	2.7	0.09	0.54	4.37	0.01	78.46%	
18		1	1.6	3.97	0.33	0.71	5.57	0	1.06	2.32	0.29	0.59	3.29	0	59.07%	
22		1	3.12	7.23	0.54	3.41	9.67	0.01	2.21	4.41	0.5	2.73	6.94	0.01	71.77%	
23		1	3.22	6.11	0.03	4.56	8.24	0.01	2.22	3.94	0.03	3.71	6.01	0.01	72.94%	
24		1	5.75	7.8	0.04	1.23	11.56	0.02	4.29	5.51	0.04	0.93	9.19	0.02	79.50%	
25		1	2.63	5.7	0.74	1.73	6.84	0.01	1.91	3.61	0.67	1.34	4.86	0.01	71.05%	
26		1	3.68	7.66	0.26	4.97	10.38	0	2.62	5.19	0.22	4.04	7.76	0	74.76%	
32		1	3.86	7.46	0.19	5.2	10.5	0	2.72	5.18	0.16	4.17	7.7	0	73.33%	
33		1	3.49	5.53	0.15	1.25	7.56	0.01	2.57	3.75	0.13	1.03	5.72	0.01	75.66%	
34		1	4.37	5.88	0.35	1.19	8.98	0.02	3.24	3.88	0.32	0.89	6.74	0.02	75.06%	
35		1	3.19	7.54	0.55	3.11	9.73	0	2.14	4.78	0.5	2.54	6.96	0	71.53%	
	128	1	1.65	2.28	0.1	1.28	3.75	0	1.05	1.37	0.09	0.93	2.63	0	70.13%	
	130	1	1.75	2.15	0.08	0.29	3.86	0	1.13	1.32	0.07	0.21	2.88	0	74.61%	
	132	1	1.22	1.54	0.11	0.17	2.57	0	0.79	0.94	0.1	0.14	1.74	0	67.70%	
	134	1	1.01	1.24	0.05	0.04	2.17	0	0.66	0.78	0.05	0.03	1.6	0	73.73%	
	136	1	3.12	4.18	0.32	1.91	7.43	0.01	1.92	2.36	0.29	1.42	4.93	0.01	66.35%	
	137	1	2.49	3.03	0.04	0.31	4.83	0	1.8	2.11	0.04	0.26	3.64	0	75.36%	
	138	1	2.06	2.41	0.2	0.1	4.31	0	1.48	1.57	0.18	0.07	3.05	0	70.77%	
	139	1	3.36	4.34	0.07	1.91	7.67	0.01	2.38	2.82	0.06	1.47	5.42	0.01	70.66%	
	144	1	3.27	4.5	0.17	1.94	7.99	0.01	2.22	2.6	0.16	1.44	5.38	0.01	67.33%	
	145	1	3.18	3.65	0.19	0.13	5.91	0	2.31	2.53	0.17	0.08	4.74	0	80.20%	
	146	1	3.28	4.49	0.14	1.94	7.97	0.01	2.28	2.68	0.13	1.45	5.42	0.01	68.01%	
	150	1	5.08	6.23	0.53	2.93	10.75	0	3.48	4.17	0.49	2.29	7.22	0	67.16%	
	151	1	5.73	7.1	0.11	2.35	10.91	0.01	4.2	4.98	0.1	1.98	8.58	0.01	78.64%	
	152	1	5.19	5.82	0.16	1.21	9.66	0.01	3.85	4.11	0.15	0.95	7.58	0.01	78.47%	
	153	1	4.78	5.86	1.03	2.49	9.22	0.01	3.25	3.68	0.93	1.94	6.38	0.01	69.20%	
	154	1	5.13	6.33	0.15	3.09	10.22	0.01	3.78	4.37	0.12	2.46	7.98	0.01	78.08%	
	160	1	5.17	6.33	0.24	3.35	10.61	0	3.84	4.46	0.2	2.63	7.76	0	73.14%	
	161	1	5.6	6.65	0.04	1.13	10.54	0.01	4.14	4.72	0.03	0.8	8.64	0.01	81.97%	
	162	1	3.63	4.39	1.03	1.53	7.65	0.01	2.67	2.98	0.94	1.09	5.35	0.01	69.93%	
	163	1	4.86	6.24	0.5	2.95	10.27	0	3.43	4.06	0.45	2.32	7.4	0	72.05%	
0	128	1	3.22	4.33	0.24	3.2	6.28	0.01	2.16	2.51	0.22	2.34	4.5	0.01	71.66%	
2	130	1	3.85	5.5	0.21	1.16	7.53	0.01	2.51	3.54	0.19	0.86	5.6	0.01	74.37%	
4	132	1	2.78	4.62	0.36	0.98	5.67	0.01	1.86	2.7	0.32	0.81	3.69	0.01	65.08%	
6	134	1	2.81	4.12	0.15	0.29	5.48	0	1.9	2.66	0.13	0.25	4.02	0	73.36%	
8	136	1	5.05	9.72	0.81	5.22	14.96	0.01	3.51	6.74	0.74	4	10.45	0.01	69.85%	
9	137	1	4.37	6.83	0.16	1.4	9.79	0.01	3.13	4.46	0.15	1.19	7.3	0.01	74.57%	
10	138	1	5.6	8.42	0.75	0.44	10.76	0.02	4.01	5.39	0.69	0.35	7.94	0.02	73.79%	
11	139	1	5.91	10.5	0.23	5.65	14.61	0.02	4.11	6.49	0.21	4.38	10.76	0.02	73.65%	
16	144	1	5.27	8.89	0.51	4	12.64	0.01	3.17	5.43	0.48	3.21	9.23	0.01	73.02%	
17	145	1	7.67	8.98	0.46	0.71	12.45	0.02	5.68	6.23	0.42	0.59	9.91	0.02	79.60%	
18	146	1	5.04	8.45	0.61	3.39	12.18	0.01	3.26	5.15	0.55	2.71	9.09	0.01	74.63%	
22	150	1	9.56	20.75	1.77	9.38	24.1	0.02	6.25	13.66	1.66	7.49	17.53	0.01	72.74%	
23	151	1	10.72	14.24	0.2	10.2	21.09	0.03	7.89	9.92	0.18	8.45	16.65	0.02	78.95%	
24	152	1	15	16.79	0.32	3.41	22.97	0.04	11.34	12.09	0.29	2.62	18.22	0.04	79.32%	
25	153	1	9.16	18.82	2.74	6.01	21.39	0.02	6.41	12.17	2.5	4.71	14.62	0.02	68.35%	
26	154	1	9.76	17.61	0.64	11.87	22.97	0.01	7.07	12.12	0.53	9.57	17.61	0.01	76.67%	
32	160	1	9.97	17.86	0.68	12.23	24.02	0.01	7.19	13	0.57	9.81	18.47	0.01	76.89%	
33	161	1	12.52	13.32	0.25	3.17	20.55	0.03	9.45	9.23	0.22	2.4	16.77	0.03	81.61%	
34	162	1	9.61	12.42	2.24	3.8	17.62	0.03	7.2	8.14	2.03	2.79	13.76	0.03	78.09%	
35	163	1	9.58	19.64	1.61	8.81	22.96	0.01	6.43	13.02	1.49	7.12	16.63	0.01	72.43%	

Table 7-2 PD of Top module (n260) Middle channel

Beam ID 1	Beam ID 2	Antenna Module	n260 module1_4cm2 Average Total PD (W/m^2)														Ratio worst surface back or top (5mm/2mm)
			Surface 2mm_Mid channel						Surface 5mm_Mid channel						80.92%		
			S1 front	S2 back	S3 left	S4 right	S5 top	S6 bottom	S1 front	S2 back	S3 left	S4 right	S5 top	S6 bottom			
0		1	1.16	1.56	0.03	1.07	2.45	0	0.78	0.86	0.03	0.78	1.69	0	68.98%		
2		1	1.22	2.41	0.05	0.53	3.53	0	0.8	1.5	0.05	0.39	2.59	0	73.37%		
4		1	1.38	3.29	0.06	0.36	4.43	0	0.87	2.15	0.05	0.29	3.32	0	74.94%		
6		1	1.11	2.16	0.07	0.18	3.11	0	0.73	1.35	0.07	0.15	2.25	0	72.35%		
8		1	2.05	5.39	0.14	1.51	7.75	0	1.37	3.07	0.13	1.19	5.13	0	66.19%		
9		1	2.32	3.49	0.08	1.32	5.07	0	1.67	2.3	0.07	1.07	3.92	0	77.32%		
10		1	2.55	5.39	0.22	0.41	7.05	0.01	1.84	3.8	0.2	0.31	5.36	0.01	76.03%		
11		1	1.89	3.77	0.04	2.32	5.49	0	1.3	2.15	0.04	1.78	3.57	0	65.03%		
16		1	2.07	5.12	0.11	0.89	7.27	0	1.37	3.03	0.1	0.74	4.95	0	68.09%		
17		1	2.88	5.08	0.08	0.38	6.98	0.01	2.06	3.55	0.07	0.32	5.57	0.01	79.80%		
18		1	2	5.43	0.19	0.79	7.27	0.01	1.39	3.33	0.18	0.65	4.94	0.01	67.95%		
22		1	4.16	8.94	0.39	3.73	11.92	0	2.78	5.72	0.36	3.02	8.88	0	74.50%		
23		1	3.72	6.69	0.04	4.51	9.92	0.01	2.71	4.51	0.04	3.71	7.39	0.01	74.50%		
24		1	5.65	9.08	0.14	0.74	12.63	0.02	4.09	6.36	0.13	0.56	10.22	0.02	80.92%		
25		1	4.08	9.05	0.46	2.5	11.19	0.01	2.98	6.27	0.42	1.79	8.66	0.01	77.39%		
26		1	3.66	7.91	0.19	4.56	10.8	0.01	2.65	5.28	0.15	3.7	7.56	0	70.00%		
32		1	3.61	7.62	0.15	4.73	10.69	0.01	2.62	4.96	0.12	3.84	7.18	0.01	67.17%		
33		1	4.61	7.33	0.15	2.01	10.29	0.01	3.39	5.18	0.14	1.66	8.17	0.01	79.40%		
34		1	4.93	8.4	0.21	1.78	11.5	0.02	3.58	5.9	0.19	1.24	8.98	0.02	78.09%		
35		1	3.8	8.43	0.36	3.32	10.75	0	2.68	5.67	0.32	2.73	8.07	0	75.07%		
	128	1	1.6	2.37	0.04	1.55	3.59	0	1.01	1.48	0.04	1.14	2.46	0	68.52%		
	130	1	2.16	2.25	0.08	0.18	3.35	0	1.51	1.47	0.07	0.14	2.39	0	71.34%		
	132	1	1.64	1.72	0.07	0.07	2.44	0	1.15	1.15	0.07	0.06	1.62	0	66.39%		
	134	1	1.17	1.22	0.04	0.04	1.84	0	0.8	0.81	0.04	0.03	1.29	0	70.11%		
	136	1	3.07	3.86	0.21	1.94	5.97	0.01	1.96	2.25	0.19	1.38	3.76	0.01	62.98%		
	137	1	2.97	3.1	0.03	0.12	4.25	0	2.26	2.22	0.03	0.1	3.06	0	72.00%		
	138	1	2.58	2.6	0.16	0.13	3.77	0.01	1.92	1.75	0.14	0.09	2.47	0.01	65.52%		
	139	1	3.56	4.41	0.06	1.84	6.91	0.01	2.35	2.66	0.05	1.37	4.69	0.01	67.87%		
	144	1	3.38	4.34	0.1	2.06	6.82	0.01	2.11	2.52	0.1	1.51	4.44	0.01	65.10%		
	145	1	3.93	3.78	0.12	0.15	5.04	0.01	3.02	2.72	0.11	0.11	3.64	0.01	72.22%		
	146	1	3.44	4.39	0.09	2.02	6.89	0.01	2.16	2.56	0.08	1.48	4.54	0	65.89%		
	150	1	5.29	6.09	0.44	2.38	9.06	0.01	3.64	4.13	0.4	1.8	6.55	0.01	72.30%		
	151	1	6.16	6.53	0.03	2.07	9.17	0.02	4.65	4.7	0.02	1.64	7.06	0.02	76.99%		
	152	1	5.97	5.35	0.13	1.54	7.71	0.02	4.55	3.9	0.12	1.2	5.42	0.02	70.30%		
	153	1	4.25	5.47	0.72	2.04	8.09	0.01	2.92	3.25	0.65	1.58	5.34	0.01	66.01%		
	154	1	5.62	6.35	0.15	2.49	9.62	0.01	4.11	4.38	0.12	1.92	7.35	0.01	76.40%		
	160	1	5.54	6.34	0.21	2.59	9.38	0.01	4.11	4.43	0.17	1.99	7.15	0.01	76.23%		
	161	1	6.26	6.71	0.03	1.1	8.82	0.02	4.8	4.93	0.03	0.78	6.54	0.02	74.15%		
	162	1	4.36	4.64	0.73	1.47	6.77	0.02	3.15	3.1	0.66	1.07	4.58	0.02	67.65%		
	163	1	5.11	6.19	0.42	2.42	9.53	0	3.57	4.03	0.39	1.84	6.82	0	71.56%		
0	128	1	3.89	4.96	0.13	3.97	6.64	0.01	2.7	3	0.12	2.96	4.78	0.01	71.99%		
2	130	1	5.25	6.6	0.25	0.95	7.86	0.01	3.67	4.48	0.23	0.7	5.85	0.01	74.43%		
4	132	1	4.73	7.32	0.18	0.66	7.43	0.01	3.27	5.01	0.16	0.53	5.53	0.01	74.43%		
6	134	1	3.43	4.81	0.18	0.27	5.5	0.01	2.36	3.22	0.16	0.23	3.99	0.01	72.55%		
8	136	1	6.1	11.6	0.54	4.92	14.36	0.02	4.26	6.95	0.5	3.76	9.91	0.01	69.01%		
9	137	1	5.67	7.31	0.13	1.77	9.33	0.01	4.02	5.17	0.12	1.46	7.04	0.01	75.46%		
10	138	1	8.1	12.15	0.58	0.74	12.18	0.02	6.14	8.87	0.52	0.55	9.31	0.02	76.44%		
11	139	1	7.12	11.82	0.15	6.31	13.75	0.01	4.62	7.36	0.13	4.88	9.8	0.01	71.27%		
16	144	1	5.4	9.05	0.28	3.94	12.64	0.01	3.79	5.71	0.25	3.14	9.64	0.01	76.27%		
17	145	1	9.23	11.27	0.31	0.56	13.53	0.03	6.91	8.2	0.28	0.49	10.6	0.03	78.34%		
18	146	1	5.75	8.84	0.38	3.27	12.63	0.01	3.98	5.81	0.35	2.61	9.54	0.01	75.53%		
22	150	1	11.63	20.07	1.36	9.09	24.22	0.02	7.89	13.32	1.26	7.31	18.03	0.01	74.44%		
23	151	1	13.99	18.82	0.11	10.49	22.37	0.05	10.48	13.5	0.1	8.67	17.31	0.05	77.38%		
24	152	1	17.38	19.55	0.47	3.89	22.55	0.07	13.08	14.41	0.43	2.99	17.56	0.07	77.87%		
25	153	1	12.43	19.17	1.98	6.2	22.82	0.04	9.24	13.42	1.8	4.81	17.33	0.03	75.94%		
26	154	1	12.37	20.08	0.52	10.77	22.99	0.02	9.15	13.76	0.41	8.67	17.61	0.02	76.60%		
32	160	1	11.83	20.12	0.56	11	22.36	0.02	8.67	14.15	0.45	8.83	17.62	0.02	78.80%		
33	161	1	14.64	19.01	0.3	3.86	21.25	0.05	11.17	14.01	0.27	3.17	16.31	0.05	76.75%		
34	162	1	14.43	18.71	1.58	4.42	21.42	0.05	10.91	13.75	1.43	3.09	16.48	0.05	76.94%		
35	163	1	10.95	19.5	1.17	8.19	22.36	0.01	7.34	12.36	1.06	6.61	16.2	0.01	72.45%		

Table 7-3 PD of Top module (n260) High channel

Beam ID 1	Beam ID 2	Antenna Module	n260 module1_4cm2 Average Total PD (W/m ²)												Ratio worst surface back or top (5mm/2mm)	
			Surface 2mm_High channel						Surface 5mm_High channel							80.27%
			S1 front	S2 back	S3 left	S4 right	S5 top	S6 bottom	S1 front	S2 back	S3 left	S4 right	S5 top	S6 bottom		
0		1	1.11	1.57	0.04	0.78	2.46	0	0.74	0.89	0.03	0.57	1.68	0	68.29%	
2		1	0.96	1.72	0.08	0.68	2.93	0	0.57	1	0.07	0.51	1.98	0	67.58%	
4		1	1.38	2.23	0.07	0.37	3.6	0	0.91	1.39	0.07	0.3	2.63	0	73.06%	
6		1	1.09	1.69	0.04	0.24	2.74	0	0.71	1.01	0.04	0.21	1.97	0	71.90%	
8		1	2.27	4	0.09	1.71	6.97	0	1.64	2.46	0.09	1.33	4.58	0	65.71%	
9		1	2.17	3.13	0.09	1.27	4.7	0	1.54	1.96	0.08	1	3.54	0	75.32%	
10		1	2.48	4.18	0.16	0.61	5.88	0.01	1.77	2.97	0.15	0.46	4.72	0.01	80.27%	
11		1	2.02	3.11	0.06	2.2	5.21	0	1.41	1.93	0.05	1.65	3.34	0	64.11%	
16		1	2.48	4.27	0.11	0.83	7.06	0	1.76	2.38	0.1	0.68	4.74	0	67.14%	
17		1	2.55	3	0.11	0.71	5.06	0.01	1.89	2.01	0.1	0.61	3.88	0.01	76.68%	
18		1	2.26	4.71	0.16	0.9	7.21	0.01	1.43	2.94	0.14	0.71	5.01	0	69.49%	
22		1	4.25	7.57	0.36	3.72	11.14	0	2.92	5.15	0.31	3.01	8.39	0	75.31%	
23		1	4.84	6.11	0.04	4.28	10	0.01	3.58	4.29	0.03	3.46	7.89	0.01	78.90%	
24		1	4.23	5.72	0.19	1.21	8.88	0.01	2.95	3.74	0.18	1	6.85	0.01	77.14%	
25		1	4.78	8.49	0.4	2.84	11.71	0.01	3.36	6.01	0.36	2.01	9.29	0.01	79.33%	
26		1	3.77	7.02	0.16	4.58	9.97	0	2.74	4.82	0.13	3.68	7.32	0	73.42%	
32		1	3.79	6.29	0.14	4.3	10.09	0	2.77	4.23	0.11	3.47	7.4	0	73.34%	
33		1	5.62	6.05	0.09	1.83	10.28	0.01	4.08	4.26	0.08	1.52	8.15	0.01	79.28%	
34		1	4.06	6.25	0.4	1.27	9.37	0.02	2.82	4.25	0.36	0.93	7.3	0.02	77.91%	
35		1	3.98	7.97	0.28	3.6	10.8	0.01	2.77	5.57	0.25	2.91	8.1	0	75.00%	
	128	1	1.41	1.89	0.02	1.35	2.57	0.01	0.9	1.15	0.02	1.01	1.7	0.01	66.15%	
	130	1	1.77	2.35	0.03	0.15	2.66	0	1.26	1.71	0.03	0.12	1.84	0	69.17%	
	132	1	1.7	1.46	0.02	0.08	2.25	0	1.24	1.02	0.02	0.06	1.66	0	73.78%	
	134	1	1.21	1.03	0.01	0.05	1.57	0	0.88	0.73	0.01	0.04	1.15	0	73.25%	
	136	1	2.52	3.64	0.11	1.95	4.89	0.01	1.76	2.24	0.1	1.49	3	0.01	61.35%	
	137	1	2.96	2.67	0.01	0.06	4.13	0	2.24	1.93	0.01	0.05	3.09	0	74.82%	
	138	1	2.89	2.34	0.03	0.16	3.81	0.01	2.21	1.68	0.03	0.11	2.8	0.01	73.49%	
	139	1	2.78	3.88	0.06	1.69	4.54	0.01	1.79	2.6	0.05	1.29	2.83	0.01	62.33%	
	144	1	2.62	3.74	0.08	2	4.63	0.01	1.61	2.38	0.08	1.55	2.69	0.01	58.10%	
	145	1	3.66	3.91	0.05	0.15	5.32	0.01	2.79	2.88	0.05	0.11	3.95	0.01	74.25%	
	146	1	2.66	3.78	0.08	1.95	4.6	0.01	1.65	2.43	0.07	1.5	2.7	0.01	58.70%	
	150	1	4.36	4.57	0.2	2.19	6.13	0.01	2.96	2.9	0.19	1.69	3.57	0.01	58.24%	
	151	1	5.55	6.23	0.04	1.64	7.51	0.02	4.31	4.63	0.03	1.29	5.49	0.02	73.10%	
	152	1	5.58	5.7	0.11	1.2	8.17	0.02	4.21	4.07	0.09	0.89	5.9	0.02	72.22%	
	153	1	4.7	4.97	0.22	1.99	6.48	0.02	3.44	3.41	0.21	1.51	4.25	0.02	65.59%	
	154	1	4.75	5.63	0.1	1.98	6.24	0.01	3.54	4.18	0.08	1.53	4.47	0.01	71.63%	
	160	1	4.42	5.17	0.14	2.17	6.13	0.01	3.36	3.75	0.12	1.68	4.19	0.01	68.35%	
	161	1	5.96	6.35	0.02	0.94	9	0.02	4.54	4.63	0.02	0.65	6.76	0.02	75.11%	
	162	1	5.14	5.9	0.2	1.42	7.66	0.03	3.82	4.18	0.18	1.05	5.33	0.02	69.58%	
	163	1	3.9	4.64	0.21	2.15	5.48	0.01	2.6	3.18	0.18	1.66	3.69	0.01	67.34%	
0	128	1	3.56	5.04	0.1	3.39	5.67	0.01	2.44	3.08	0.09	2.55	3.77	0.01	66.49%	
2	130	1	4.41	5.46	0.21	1.23	6.77	0.01	3.02	3.77	0.19	0.92	4.77	0.01	70.46%	
4	132	1	4.98	5.34	0.12	0.58	7.08	0.01	3.51	3.65	0.11	0.46	5.23	0.01	73.87%	
6	134	1	3.78	4.13	0.07	0.28	5.29	0.01	2.68	2.79	0.07	0.24	3.94	0.01	74.48%	
8	136	1	6.59	9.75	0.31	4.83	12.53	0.02	4.62	5.91	0.29	3.76	9.06	0.02	72.31%	
9	137	1	5.17	6.23	0.13	1.39	8.98	0.01	3.85	4.48	0.12	1.11	6.99	0.01	77.84%	
10	138	1	8.69	9.38	0.27	0.93	12.47	0.02	6.59	7.01	0.24	0.73	9.84	0.02	78.91%	
11	139	1	6.75	10.72	0.16	5.98	10.43	0.02	4.08	7.07	0.15	4.64	7.19	0.02	67.07%	
16	144	1	4.86	7.68	0.32	3.95	10.64	0.02	3.57	5	0.29	3.24	7.53	0.02	70.77%	
17	145	1	7.88	7.77	0.26	1.35	12.48	0.02	5.81	5.53	0.23	1.17	9.61	0.02	77.00%	
18	146	1	4.77	7.97	0.37	2.79	10.44	0.02	3.4	5.46	0.33	2.23	7.74	0.02	74.14%	
22	150	1	12.82	17	0.92	7.54	21.17	0.02	8.71	10.96	0.82	5.99	15.84	0.02	74.82%	
23	151	1	16.06	19.28	0.14	9.38	19.79	0.05	12.38	14.17	0.12	7.71	15.57	0.05	78.68%	
24	152	1	13.99	14.38	0.54	4.4	19.58	0.05	10.42	10.13	0.49	3.48	15.08	0.05	77.02%	
25	153	1	15.09	18.06	1.05	5.61	22.86	0.05	11.26	13.55	0.95	4.37	17.45	0.05	76.33%	
26	154	1	12.11	18.5	0.37	9.5	17.9	0.02	9.06	13.09	0.31	7.61	13.43	0.02	72.59%	
32	160	1	11.49	18.74	0.39	9.97	18.39	0.02	8.53	13.52	0.31	8.03	14.28	0.02	76.20%	
33	161	1	16.5	18.18	0.13	3.75	20.94	0.05	12.61	13.25	0.12	3.13	16.54	0.05	78.99%	
34	162	1	14.36	16.72	1.04	3.51	21.63	0.06	10.59	12.4	0.93	2.51	16.7	0.06	77.21%	
35	163	1	11.4	17.23	0.8	7.78	19.48	0.02	8.38	12.13	0.73	6.11	14.37	0.02	73.77%	

Table 7-4 PD of Top module (n261) Low channel

Beam ID 1	Beam ID 2	Antenna Module	n261 module1_4cm2 Average Total PD (W/m ²)												Ratio worst surface back or top (5mm/2mm)
			Surface 2mm_low channel						Surface 5mm_low channel						
			S1 front	S2 back	S3 left	S4 right	S5 top	S6 bottom	S1 front	S2 back	S3 left	S4 right	S5 top	S6 bottom	
0		1	1.03	1.09	0.02	0.61	1.95	0	0.69	0.65	0.02	0.43	1.42	0	72.82%
1		1	1.64	1.87	0.03	0.61	3.05	0	1.11	1.17	0.03	0.49	2.12	0	69.51%
2		1	1.61	1.88	0.04	0.15	3.3	0	1.07	1.23	0.03	0.12	2.46	0	74.55%
6		1	1.86	2.71	0.09	2.05	4.37	0	1.21	1.63	0.08	1.57	2.73	0	62.47%
7		1	3.27	3.12	0.02	0.52	5.14	0.01	2.4	2.19	0.02	0.35	4.05	0.01	78.79%
8		1	1.85	2.62	0.08	1.95	4.22	0	1.22	1.41	0.07	1.51	2.63	0	62.32%
12		1	2.15	2.57	0.06	1.64	4.18	0.01	1.53	1.5	0.06	1.3	2.75	0.01	65.79%
13		1	2.48	3.02	0.08	1.84	4.94	0.01	1.77	2.01	0.08	1.37	3.5	0.01	70.85%
16		1	3.74	5.32	0.31	4.15	7.57	0.01	2.44	3.28	0.28	3.38	5.37	0.01	70.94%
17		1	6.31	6.62	0.1	0.99	11.12	0.03	4.62	4.71	0.08	0.74	8.91	0.03	80.13%
18		1	7.31	7.73	0.01	0.4	12.59	0.04	5.44	5.55	0.01	0.3	10.1	0.04	80.22%
19		1	7.11	7.57	0.07	3.37	12.64	0.02	5.16	5.18	0.06	2.66	9.99	0.02	79.03%
20		1	3.27	4.82	0.33	3.96	6.69	0.01	2.16	2.98	0.3	3.24	4.62	0.01	69.06%
26		1	4.83	4.92	0.31	1.98	8.73	0.02	3.46	3.4	0.27	1.61	6.78	0.02	77.66%
27		1	6.82	7.3	0.06	0.62	11.95	0.04	5.03	5.23	0.05	0.51	9.51	0.04	79.58%
28		1	7.67	8.01	0.05	1.82	13.13	0.05	5.64	5.7	0.04	1.27	10.62	0.05	80.88%
29		1	4.97	6.38	0.22	4.28	9.74	0.01	3.4	4.06	0.21	3.43	7.23	0.01	74.23%
	128	1	1.25	1.71	0.05	0.59	2.6	0	0.82	1.09	0.05	0.41	1.89	0	72.69%
	129	1	1.41	1.83	0.03	0.47	3.16	0	0.91	1.18	0.03	0.37	2.33	0	73.73%
	130	1	1.06	1.25	0.02	0.13	2.23	0	0.71	0.79	0.02	0.12	1.67	0	74.89%
	134	1	1.57	2.02	0.1	0.65	3.72	0	1.04	1.19	0.09	0.56	2.37	0	63.71%
	135	1	3.13	4.12	0.02	0.53	6.16	0	2.27	2.93	0.02	0.34	5.07	0	82.31%
	136	1	2.17	2.88	0.13	1.86	4.91	0	1.3	1.58	0.12	1.4	3.12	0	63.54%
	140	1	2.59	3.44	0.06	1.17	5.55	0	1.87	2.36	0.06	0.91	4.15	0	74.77%
	141	1	2.67	3.11	0.15	1.79	5.11	0	1.91	2.19	0.14	1.31	3.62	0	70.84%
	144	1	4.66	5.09	0.48	4.2	7.59	0.01	3.33	3.6	0.43	3.34	5.64	0.01	74.31%
	145	1	5.46	6.51	0.04	0.28	10.53	0	4.03	4.66	0.04	0.19	8.56	0	81.29%
	146	1	5.99	7.29	0.03	0.31	11.68	0	4.4	5.15	0.03	0.21	9.43	0	80.74%
	147	1	5.55	6.5	0.08	3	10.27	0	4.06	4.67	0.08	2.34	8.16	0	79.45%
	148	1	3.76	4.26	0.42	4.22	6.3	0.01	2.6	2.81	0.37	3.42	4.34	0.01	68.89%
	154	1	3.58	4.37	0.33	3.15	7.04	0.01	2.61	2.99	0.29	2.52	5.39	0.01	76.56%
	155	1	5.81	7.07	0.04	0.47	11.33	0.01	4.28	5	0.04	0.37	9.18	0.01	81.02%
	156	1	5.82	7.01	0.06	0.91	11.01	0.01	4.31	4.99	0.05	0.57	8.98	0.01	81.56%
	157	1	4.7	5.27	0.44	4.13	8.05	0.01	3.34	3.58	0.39	3.29	5.73	0.01	71.18%
0	128	1	2.99	3.25	0.14	1.88	5.43	0	1.99	2	0.13	1.33	3.95	0	72.74%
1	129	1	3.25	4.17	0.09	1.27	6.54	0.01	2.22	2.74	0.08	1.01	4.68	0.01	71.56%
2	130	1	3.12	3.83	0.09	0.37	5.82	0.01	2.13	2.49	0.08	0.32	4.34	0	74.57%
6	134	1	3.51	5.84	0.32	3.54	7.87	0.01	2.34	3.41	0.29	2.86	5.05	0.01	64.17%
7	135	1	7.33	8.42	0.06	1.32	12.13	0.02	5.42	6.02	0.06	0.9	9.75	0.02	80.38%
8	136	1	5.02	6.55	0.36	5.3	9.83	0.01	3.04	4.22	0.33	4.05	6.39	0.01	65.01%
12	140	1	5.43	7.49	0.22	3.76	10.41	0.01	3.76	5.05	0.21	2.94	7.87	0.01	75.60%
13	141	1	5.97	8.18	0.39	5.08	11.59	0.01	4.22	5.46	0.35	3.76	8.49	0.01	73.25%
16	144	1	10.62	15.36	1.37	12.04	19.86	0.02	7.3	10.28	1.23	9.7	14.02	0.02	70.59%
17	145	1	13.69	14.26	0.21	1.48	23.86	0.04	10.12	10.06	0.16	1.04	19.28	0.04	80.80%
18	146	1	14.38	16.8	0.06	0.83	25.17	0.05	10.72	11.99	0.05	0.58	20.15	0.05	80.06%
19	147	1	15.07	17.81	0.22	7.35	25.19	0.03	11.05	12.22	0.2	5.78	19.93	0.03	79.12%
20	148	1	9.37	14.17	1.3	12.13	17.88	0.02	6.48	9.1	1.16	9.87	12.38	0.02	69.24%
26	154	1	11.65	12.18	1.02	7.45	20.67	0.03	8.57	8.25	0.92	6.03	15.69	0.03	75.91%
27	155	1	13.32	15.6	0.17	1.56	24.46	0.05	9.95	11.19	0.15	1.24	19.63	0.05	80.25%
28	156	1	15.25	17.59	0.17	3.11	25.22	0.07	11.32	12.45	0.15	2.08	20.39	0.06	80.85%
29	157	1	12.51	17.19	1.11	11.75	22.48	0.02	8.5	10.95	1	9.38	15.97	0.01	71.04%

Table 7-5 PD of Top module (n261) Middle channel

Beam ID 1	Beam ID 2	Antenna Module	n261 module1_4cm2 Average Total PD (W/m^2)														Ratio worst surface back or top (5mm/2mm)
			Surface 2mm_Mid channel						Surface 5mm_Mid channel						81.74%		
			S1 front	S2 back	S3 left	S4 right	S5 top	S6 bottom	S1 front	S2 back	S3 left	S4 right	S5 top	S6 bottom			
0		1	0.99	1.09	0.03	0.72	1.9	0	0.66	0.64	0.03	0.52	1.38	0	72.63%		
1		1	1.48	1.61	0.03	0.42	2.79	0	0.98	1.01	0.03	0.34	1.96	0	70.25%		
2		1	1.5	1.79	0.04	0.15	3.1	0	0.99	1.17	0.03	0.12	2.31	0	74.52%		
6		1	1.85	2.49	0.11	1.9	4.2	0	1.2	1.48	0.1	1.45	2.6	0	61.90%		
7		1	2.73	2.64	0.02	0.53	4.47	0.01	2.01	1.82	0.02	0.36	3.49	0.01	78.08%		
8		1	1.85	2.41	0.1	1.8	4.01	0	1.23	1.31	0.09	1.4	2.49	0	62.09%		
12		1	2.06	2.33	0.08	1.5	3.86	0	1.43	1.35	0.07	1.19	2.56	0	66.32%		
13		1	2.37	2.69	0.09	1.74	4.68	0.01	1.7	1.76	0.08	1.29	3.19	0.01	68.16%		
16		1	3.9	5.09	0.31	3.93	7.48	0.01	2.51	3.19	0.28	3.18	5.27	0.01	70.45%		
17		1	5.85	6.12	0.11	0.88	10.3	0.02	4.27	4.34	0.09	0.65	8.21	0.02	79.71%		
18		1	6.62	7.1	0.01	0.44	11.5	0.03	4.94	5.13	0.01	0.32	9.27	0.03	80.61%		
19		1	6.78	7.09	0.06	3.16	11.86	0.02	4.96	4.89	0.05	2.49	9.46	0.02	79.76%		
20		1	3.45	4.6	0.33	3.81	6.61	0.01	2.32	2.86	0.3	3.09	4.53	0.01	68.53%		
26		1	4.79	4.67	0.31	1.99	8.37	0.02	3.41	3.24	0.28	1.61	6.46	0.02	77.18%		
27		1	6.23	6.82	0.05	0.65	11.11	0.03	4.59	4.9	0.04	0.53	8.86	0.03	79.75%		
28		1	7.12	7.44	0.05	1.68	12.14	0.04	5.28	5.32	0.04	1.17	9.85	0.04	81.14%		
29		1	5.04	6.07	0.23	3.96	9.49	0.01	3.41	3.89	0.21	3.16	7.07	0.01	74.50%		
	128	1	1.11	1.44	0.04	0.51	2.24	0	0.73	0.91	0.04	0.35	1.61	0	71.88%		
	129	1	1.44	1.77	0.03	0.46	3.12	0	0.94	1.14	0.03	0.36	2.3	0	73.72%		
	130	1	1.08	1.22	0.02	0.12	2.23	0	0.73	0.78	0.02	0.1	1.66	0	74.44%		
	134	1	1.62	1.96	0.11	0.6	3.74	0	1.05	1.13	0.1	0.51	2.38	0	63.64%		
	135	1	3.02	3.74	0.02	0.46	5.75	0	2.2	2.66	0.02	0.28	4.7	0	81.74%		
	136	1	2.04	2.61	0.12	1.75	4.58	0	1.22	1.42	0.11	1.31	2.91	0	63.54%		
	140	1	2.47	3.08	0.05	1.15	5.15	0	1.78	2.12	0.05	0.9	3.84	0	74.56%		
	141	1	2.49	2.84	0.14	1.59	4.77	0	1.78	1.99	0.12	1.16	3.34	0	70.02%		
	144	1	4.3	4.69	0.48	3.76	7.01	0.01	3.09	3.31	0.43	2.98	5.2	0.01	74.18%		
	145	1	5.41	6.29	0.05	0.31	10.27	0	4	4.49	0.04	0.24	8.34	0	81.21%		
	146	1	5.93	6.9	0.03	0.24	11.25	0	4.37	4.87	0.02	0.16	9.08	0	80.71%		
	147	1	5.42	5.97	0.08	2.74	9.74	0	3.98	4.31	0.07	2.12	7.69	0	78.95%		
	148	1	3.58	4.04	0.4	4	6.02	0.01	2.49	2.72	0.36	3.23	4.16	0.01	69.10%		
	154	1	3.44	4.04	0.3	3.14	6.77	0.01	2.53	2.76	0.27	2.52	5.16	0.01	76.22%		
	155	1	5.82	6.79	0.04	0.42	11.12	0	4.3	4.79	0.03	0.33	8.98	0	80.76%		
	156	1	5.83	6.65	0.05	0.81	10.69	0.01	4.33	4.74	0.04	0.52	8.7	0.01	81.38%		
	157	1	4.42	4.82	0.44	3.69	7.47	0.01	3.11	3.29	0.39	2.93	5.33	0.01	71.35%		
0	128	1	2.9	3.1	0.14	1.93	5.19	0.01	1.91	1.9	0.13	1.38	3.73	0	71.87%		
1	129	1	3.44	3.88	0.09	1.23	6.08	0.01	2.3	2.5	0.09	0.97	4.37	0.01	71.88%		
2	130	1	3.13	3.67	0.09	0.38	5.49	0	2.13	2.4	0.08	0.33	4.07	0	74.13%		
6	134	1	3.47	5.6	0.37	3.54	7.78	0.01	2.31	3.3	0.33	2.86	4.95	0.01	63.62%		
7	135	1	7.06	7.51	0.06	1.27	10.98	0.01	5.23	5.31	0.06	0.86	8.81	0.01	80.24%		
8	136	1	5.17	6.3	0.38	5.39	9.9	0.01	3.46	4.09	0.35	4.12	6.37	0.01	64.34%		
12	140	1	5.82	6.35	0.22	3.89	10.11	0.01	4.14	4.24	0.2	3.04	7.52	0.01	74.38%		
13	141	1	6.3	7.53	0.4	5.05	11.49	0.01	4.45	5.01	0.36	3.74	8.31	0.01	72.32%		
16	144	1	11.6	14.74	1.42	12.1	20.3	0.02	8.01	9.89	1.27	9.71	14.23	0.02	70.10%		
17	145	1	13.77	13.13	0.23	1.49	22.92	0.04	10.3	9.09	0.18	1.07	18.38	0.04	80.19%		
18	146	1	14.72	15.94	0.06	0.79	23.36	0.05	11.02	11.43	0.05	0.55	18.82	0.04	80.57%		
19	147	1	15.55	16.98	0.22	7.09	24.37	0.03	11.54	11.79	0.2	5.58	19.34	0.03	79.36%		
20	148	1	10.37	13.92	1.34	12.69	18.66	0.02	7.36	9.1	1.2	10.29	13	0.02	69.67%		
26	154	1	12.18	11.4	1.07	8.24	20.49	0.02	8.98	7.7	0.96	6.67	15.54	0.02	75.84%		
27	155	1	13.67	14.75	0.16	1.57	22.98	0.04	10.26	10.63	0.14	1.26	18.16	0.04	79.03%		
28	156	1	15.72	16.88	0.16	2.95	24.06	0.06	11.74	11.98	0.15	1.99	19.43	0.06	80.76%		
29	157	1	13.26	16.43	1.16	11.59	22.74	0.01	9.09	10.54	1.05	9.23	16.22	0.01	71.33%		

Table 7-6 PD of Top module (n261) High channel

Beam ID 1	Beam ID 2	Antenna Module	n261 module1_4cm2 Average Total PD (W/m ²)														Ratio worst surface back or top (5mm/2mm)
			Surface 2mm_High channel						Surface 5mm_High channel						81.50%		
			S1 front	S2 back	S3 left	S4 right	S5 top	S6 bottom	S1 front	S2 back	S3 left	S4 right	S5 top	S6 bottom			
0		1	0.92	1.06	0.03	0.74	1.81	0	0.61	0.64	0.03	0.54	1.32	0	72.93%		
1		1	1.4	1.56	0.03	0.33	2.74	0	0.92	0.99	0.02	0.25	1.99	0	72.63%		
2		1	1.36	1.62	0.03	0.14	2.81	0	0.9	1.06	0.03	0.11	2.1	0	74.73%		
6		1	1.74	2.38	0.1	1.81	4	0	1.13	1.42	0.09	1.38	2.5	0	62.50%		
7		1	2.53	2.53	0.02	0.54	4.39	0.01	1.83	1.72	0.02	0.38	3.46	0.01	78.82%		
8		1	1.81	2.28	0.09	1.65	3.83	0	1.21	1.24	0.08	1.27	2.41	0	62.92%		
12		1	2.05	2.19	0.07	1.28	3.76	0	1.42	1.33	0.07	1	2.6	0	69.15%		
13		1	2.18	2.63	0.08	1.77	4.49	0.01	1.56	1.68	0.08	1.31	3.05	0.01	67.93%		
16		1	3.92	4.85	0.27	3.79	7.34	0.01	2.5	3.12	0.24	3.05	5.24	0.01	71.39%		
17		1	5.48	5.78	0.1	0.67	9.67	0.02	3.99	4.1	0.08	0.48	7.71	0.02	79.73%		
18		1	6.06	6.52	0.01	0.39	10.58	0.03	4.53	4.71	0.01	0.27	8.55	0.03	80.81%		
19		1	6.23	6.54	0.06	2.98	10.93	0.02	4.58	4.54	0.05	2.35	8.76	0.02	80.15%		
20		1	3.47	4.4	0.29	3.68	6.52	0.01	2.29	2.82	0.26	2.96	4.53	0.01	69.48%		
26		1	4.56	4.49	0.28	1.9	7.88	0.02	3.21	3.12	0.25	1.52	6.15	0.02	78.05%		
27		1	5.86	6.44	0.04	0.5	10.47	0.03	4.33	4.62	0.04	0.4	8.43	0.02	80.52%		
28		1	6.45	6.83	0.03	1.53	11.11	0.03	4.81	4.89	0.03	1.06	9.01	0.03	81.10%		
29		1	4.91	5.74	0.2	3.84	9.12	0.01	3.33	3.75	0.18	3.07	6.87	0.01	75.33%		
128		1	0.94	1.11	0.03	0.44	1.81	0	0.62	0.69	0.03	0.31	1.3	0	71.82%		
129		1	1.33	1.5	0.03	0.4	2.74	0	0.88	0.95	0.03	0.31	2.01	0	73.36%		
130		1	1	1.09	0.03	0.09	2.03	0	0.67	0.69	0.02	0.08	1.51	0	74.38%		
134		1	1.5	1.74	0.11	0.48	3.44	0	0.96	0.98	0.1	0.41	2.17	0	63.08%		
135		1	2.69	2.95	0.02	0.32	4.81	0	1.98	2.09	0.01	0.19	3.92	0	81.50%		
136		1	1.79	2.2	0.1	1.58	3.96	0	1.1	1.21	0.09	1.18	2.5	0	63.13%		
140		1	2.1	2.49	0.04	1.12	4.34	0	1.51	1.66	0.04	0.87	3.15	0	72.58%		
141		1	2.23	2.34	0.12	1.3	4.11	0	1.6	1.62	0.11	0.94	2.88	0	70.07%		
144		1	3.74	3.85	0.45	3.07	5.92	0.01	2.69	2.71	0.4	2.42	4.39	0.01	74.16%		
145		1	4.73	5.3	0.04	0.38	8.86	0	3.5	3.77	0.03	0.29	7.16	0	80.81%		
146		1	5.41	5.87	0.02	0.16	9.84	0	4.01	4.15	0.02	0.1	7.98	0	81.10%		
147		1	4.95	4.96	0.07	2.3	8.5	0	3.68	3.58	0.07	1.77	6.68	0	78.59%		
148		1	3.18	3.54	0.37	3.46	5.27	0.01	2.21	2.41	0.33	2.78	3.68	0.01	69.83%		
154		1	3.06	3.46	0.26	2.82	6.03	0.01	2.26	2.36	0.23	2.26	4.55	0.01	75.46%		
155		1	5.3	5.86	0.03	0.39	9.85	0	3.92	4.13	0.03	0.31	7.96	0	80.81%		
156		1	5.39	5.66	0.04	0.66	9.44	0.01	4.01	4.02	0.04	0.42	7.69	0.01	81.46%		
157		1	3.9	4.03	0.41	3.07	6.42	0.01	2.74	2.76	0.37	2.42	4.61	0.01	71.81%		
0	128	1	2.7	2.91	0.13	1.92	4.87	0	1.76	1.79	0.11	1.39	3.49	0	71.66%		
1	129	1	3.54	3.52	0.08	1.14	6.01	0.01	2.38	2.22	0.08	0.89	4.35	0.01	72.38%		
2	130	1	3.05	3.29	0.08	0.34	5.29	0	2.08	2.16	0.07	0.29	3.92	0	74.10%		
6	134	1	3.16	5.14	0.37	3.32	7.18	0.01	2.16	3.07	0.33	2.67	4.58	0.01	63.79%		
7	135	1	6.89	6.49	0.05	1.14	10.18	0.01	5.1	4.52	0.05	0.76	8.14	0.01	79.96%		
8	136	1	4.93	5.94	0.34	5.28	9.8	0.01	3.31	3.94	0.31	4.03	6.06	0.01	61.84%		
12	140	1	5.81	5.29	0.2	3.89	9.78	0.01	4.13	3.48	0.18	3.03	7.09	0.01	72.49%		
13	141	1	6.26	7.03	0.35	4.82	11.15	0.01	4.42	4.68	0.32	3.56	7.96	0.01	71.39%		
16	144	1	11.88	13.4	1.28	11.26	19.45	0.02	8.08	9.02	1.15	9.01	13.53	0.02	69.56%		
17	145	1	13.41	12.24	0.21	1.5	21.82	0.03	10.1	8.44	0.17	1.07	17.43	0.03	79.88%		
18	146	1	14.62	14.2	0.06	0.69	22.4	0.04	10.95	10.21	0.06	0.48	18.12	0.04	80.89%		
19	147	1	15.35	15.35	0.21	6.74	23.16	0.03	11.45	10.76	0.19	5.29	18.38	0.02	79.36%		
20	148	1	10.69	13.11	1.21	12.24	18.26	0.02	7.43	8.76	1.08	9.88	12.71	0.02	69.61%		
26	154	1	11.55	10.35	0.96	8.12	18.93	0.02	8.48	6.96	0.86	6.53	14.47	0.02	76.44%		
27	155	1	13.84	13.23	0.13	1.45	22.29	0.03	10.37	9.57	0.12	1.15	17.82	0.03	79.95%		
28	156	1	15.44	15.09	0.14	2.71	23.02	0.05	11.6	10.73	0.12	1.86	18.6	0.05	80.80%		
29	157	1	13.49	15.06	1.07	10.93	22.03	0.01	9.25	9.8	0.97	8.68	15.91	0.01	72.22%		