

FC

Test Report

Product Name	Motorola Bluetooth Keyboard
Model No.	P6LT1
FCC ID.	IHDP6LT1

Applicant	Motorola Mobility, Inc.
Address	600 N. U.S. Highway 45, Libertyville, Illinois 60048-5343, United States

Date of Receipt	Sep. 14, 2010
Issued Date	Sep. 28, 2010
Report No.	109237R-RFUSP43V01
Report Version	V1.0

The Test Results relate only to the samples tested.

The test report shall not be reproduced except in full without the written approval of Quietek Corporation.

This report must not be used to claim product endorsement by NVLAP any agency of the U.S. Government

Test Report Certification

Issued Date: Sep. 28, 2010

Report No.: 109237R-RFUSP43V01



Product Name	Motorola Bluetooth Keyboard
Applicant	Motorola Mobility, Inc.
Address	600 N. U.S. Highway 45, Libertyville, Illinois 60048-5343, United States
Manufacturer	Darfon Electronics (Suzhou) Co., Ltd.
Model No.	P6LT1
FCC ID.	IHDP6LT1
EUT Rated Voltage	DC 3V (Power by Battery 1.5V*2)
EUT Test Voltage	DC 3V (Power by Battery 1.5V*2)
Trade Name	MOTOROLA
Applicable Standard	FCC CFR Title 47 Part 15 Subpart C: 2009 ANSI C63.4: 2003
Test Result	Complied



The Test Results relate only to the samples tested.
 The test report shall not be reproduced except in full without the written approval of QuietTek Corporation.
 This report must not be used to claim product endorsement by NVLAP any agency of the U.S. Government

Documented By : Leven Huang
 (Adm. Specialist / Leven Huang)



Tested By : Vincent chu
 (Assistant Engineer / Vincent Chu)



Approved By : [Signature]
 (Manager / Vincent Lin)

TABLE OF CONTENTS

Description	Page
1. GENERAL INFORMATION	5
1.1. EUT Description.....	5
1.2. Operational Description.....	7
1.3. Tested System Details.....	8
1.4. Configuration of Tested System	8
1.5. EUT Exercise Software	9
1.6. Test Facility	10
2. PEAK POWER OUTPUT	11
2.1. Test Equipment.....	11
2.2. Test Setup	11
2.3. Limit 11	11
2.4. Test Procedure	11
2.5. Uncertainty	11
2.6. Test Result of Peak Power Output.....	12
3. RADIATED EMISSION	13
3.1. Test Equipment.....	13
3.2. Test Setup	13
3.3. Limits.....	14
3.4. Test Procedure	15
3.5. Uncertainty	15
3.6. Test Result of Radiated Emission.....	16
4. RF ANTENNA CONDUCTED TEST	20
4.1. Test Equipment.....	20
4.2. Test Setup	20
4.3. Limits.....	20
4.4. Test Procedure	20
4.5. Uncertainty	20
4.6. Test Result of RF Antenna Conducted Test.....	21
5. BAND EDGE	24
5.1. Test Equipment.....	24
5.2. Test Setup	25
5.3. Limit 26	26
5.4. Test Procedure	26
5.5. Uncertainty	26
5.6. Test Result of Band Edge	27
6. CHANNEL NUMBER.....	31
6.1. Test Equipment.....	31
6.2. Test Setup	31
6.3. Limit 31	31
6.4. Test Procedure	31
6.5. Uncertainty	31
6.6. Test Result of Channel Number.....	32
7. CHANNEL SEPARATION.....	35
7.1. Test Equipment.....	35
7.2. Test Setup	35
7.3. Limit 35	35
7.4. Test Procedure	35
7.5. Uncertainty	35
7.6. Test Result of Channel Separation.....	36
8. DWELL TIME.....	38
8.1. Test Equipment.....	38
8.2. Test Setup	38
8.3. Limit 38	38
8.4. Test Procedure	38
8.5. Uncertainty	38
8.6. Test Result of Dwell Time	39
9. OCCUPIED BANDWIDTH	41
9.1. Test Equipment.....	41

9.2.	Test Setup	41
9.3.	Limits.....	41
9.4.	Test Procedure	41
9.5.	Uncertainty	41
9.6.	Test Result of Occupied Bandwidth	42
10.	EMI REDUCTION METHOD DURING COMPLIANCE TESTING	45

Attachment 1: EUT Test Photographs
Attachment 2: EUT Detailed Photographs

1. GENERAL INFORMATION

1.1. EUT Description

Product Name	Motorola Bluetooth Keyboard
Trade Name	MOTOROLA
Model No.	P6LT1
FCC ID.	IHDP6LT1
Frequency Range	2402 – 2480MHz
Channel Number	79
Type of Modulation	FHSS: GFSK(1Mbps)
Antenna Type	Printed on PCB
Channel Control	Auto
Antenna Gain	Refer to the table “Antenna List”

Antenna List

No.	Manufacturer	Part No.	Peak Gain
1	Darfon	N/A	0.42dBi for 2.4 GHz

Note: The antenna of EUT is conform to FCC 15.203

Frequency of Each Channel:

Channel	Frequency	Channel	Frequency	Channel	Frequency	Channel	Frequency
Channel 00:	2402 MHz	Channel 20:	2422 MHz	Channel 40:	2442 MHz	Channel 60:	2462 MHz
Channel 01:	2403 MHz	Channel 21:	2423 MHz	Channel 41:	2443 MHz	Channel 61:	2463 MHz
Channel 02:	2404 MHz	Channel 22:	2424 MHz	Channel 42:	2444 MHz	Channel 62:	2464 MHz
Channel 03:	2405 MHz	Channel 23:	2425 MHz	Channel 43:	2445 MHz	Channel 63:	2465 MHz
Channel 04:	2406 MHz	Channel 24:	2426 MHz	Channel 44:	2446 MHz	Channel 64:	2466 MHz
Channel 05:	2407 MHz	Channel 25:	2427 MHz	Channel 45:	2447 MHz	Channel 65:	2467 MHz
Channel 06:	2408 MHz	Channel 26:	2428 MHz	Channel 46:	2448 MHz	Channel 66:	2468 MHz
Channel 07:	2409 MHz	Channel 27:	2429 MHz	Channel 47:	2449 MHz	Channel 67:	2469 MHz
Channel 08:	2410 MHz	Channel 28:	2430 MHz	Channel 48:	2450 MHz	Channel 68:	2470 MHz
Channel 09:	2411 MHz	Channel 29:	2431 MHz	Channel 49:	2451 MHz	Channel 69:	2471 MHz
Channel 10:	2412 MHz	Channel 30:	2432 MHz	Channel 50:	2452 MHz	Channel 70:	2472 MHz
Channel 11:	2413 MHz	Channel 31:	2433 MHz	Channel 51:	2453 MHz	Channel 71:	2473 MHz
Channel 12:	2414 MHz	Channel 32:	2434 MHz	Channel 52:	2454 MHz	Channel 72:	2474 MHz
Channel 13:	2415 MHz	Channel 33:	2435 MHz	Channel 53:	2455 MHz	Channel 73:	2475 MHz
Channel 14:	2416 MHz	Channel 34:	2436 MHz	Channel 54:	2456 MHz	Channel 74:	2476 MHz
Channel 15:	2417 MHz	Channel 35:	2437 MHz	Channel 55:	2457 MHz	Channel 75:	2477 MHz
Channel 16:	2418 MHz	Channel 36:	2438 MHz	Channel 56:	2458 MHz	Channel 76:	2478 MHz
Channel 17:	2419 MHz	Channel 37:	2439 MHz	Channel 57:	2459 MHz	Channel 77:	2479 MHz
Channel 18:	2420 MHz	Channel 38:	2440 MHz	Channel 58:	2460 MHz	Channel 78:	2480 MHz
Channel 19:	2421 MHz	Channel 39:	2441 MHz	Channel 59:	2461 MHz		

Note:

1. This device is a Motorola Bluetooth Keyboard with a built-in 2.4GHz Bluetooth V2.0 transceiver.
2. These tests were conducted on a sample for the purpose of demonstrating compliance of Bluetooth transmitter with Part 15 Subpart C Paragraph 15.247 for spread spectrum devices.
3. Regarding to the operation frequency, the lowest, middle and highest frequency are selected to perform the test.
4. The radiation measurements are performed in X, Y, Z axis positioning. Only the worst case is shown in the report.

Test Mode	Mode 1: Transmit - 1Mbps (GFSK)
-----------	---------------------------------

1.3. Tested System Details

The types for all equipment, plus descriptions of all cables used in the tested system (including inserted cards) are:

Product	Manufacturer	Model No.	Serial No.	FCC ID	Power Cord
1 Notebook PC	DELL	PPT	N/A	DoC	Non-Shielded, 0.8m
2 Monitor	Dell	2407WFPb	CN-0YY528-46633-79 6-12TS	DoC	Non-Shielded, 1.8m
3 USB Mouse	Logitech	M-BE58	HCA30102991	DoC	N/A
4 Microphone & Earphone	PCHOME	N/A	N/A	N/A	N/A
5 Test Fixture	Darfon	N/A	N/A	N/A	N/A

Signal Cable Type		Signal cable Description
A	USB Cable	Non-shielded,1m
B	VGA Cable	Non-shielded,1.2m
C	USB Cable	Non-shielded,1.1m
D	Microphone & Earphone Cable	Non-shielded,1.2m
E	RS-232 Cable	Non-shielded,1m
F	Control Cable	Non-shielded,0.2m

1.4. Configuration of Tested System

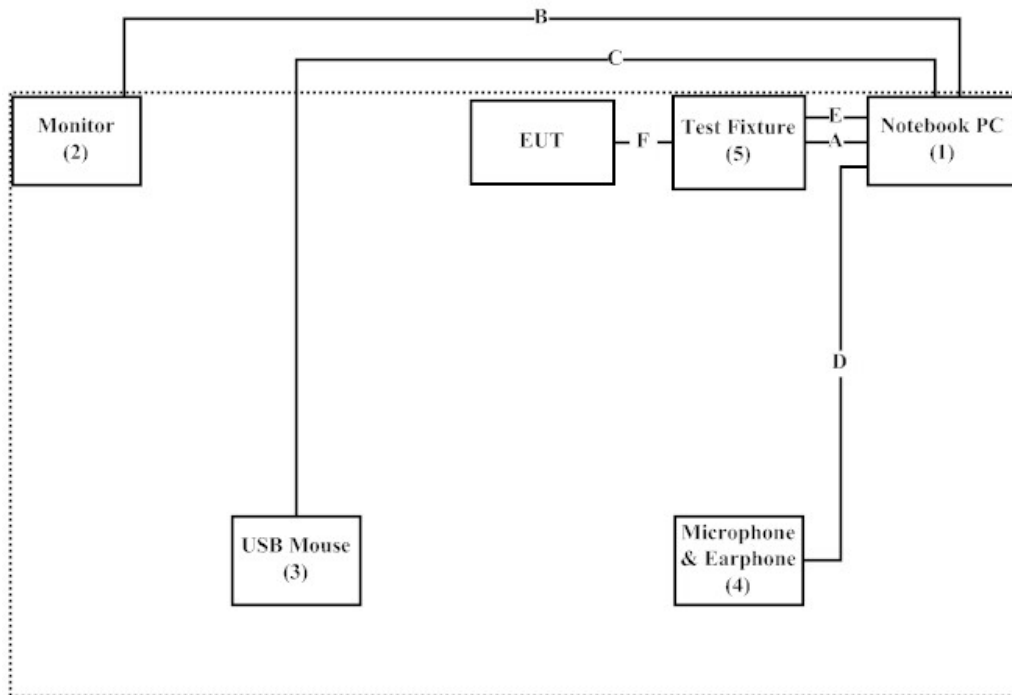

1.5. EUT Exercise Software

- (1) Setup the EUT as shown in section 1.4
- (2) Execute the program (the continuous transmission program) on the EUT
- (3) Setup the test mode, the test channel, and the data rate.
- (4) Press OK to start the transmission.
- (5) Verify that the EUT works correctly.

1.6. Test Facility

Ambient conditions in the laboratory:

Items	Required (IEC 68-1)	Actual
Temperature (°C)	15-35	20-35
Humidity (%RH)	25-75	30-65
Barometric pressure (mbar)	860-1060	950-1000

The related certificate for our laboratories about the test site and management system can be downloaded

from Quietek Corporation's Web Site : <http://www.quietek.com/tw/ctg/cts/accreditations.htm>

The address and introduction of Quietek Corporation's laboratories can be founded in our Web site : <http://www.quietek.com/>

Site Description: File on
 Federal Communications Commission
 FCC Engineering Laboratory
 7435 Oakland Mills Road
 Columbia, MD 21046
 Registration Number: 92195



Accreditation on NVLAP
 NVLAP Lab Code: 200533-0



Site Name: Quietek Corporation
 Site Address: No. 5-22, Ruei-Shu Valley, Ruei-Ping Tsuen,
 Lin-Kou Shiang, Taipei,
 Taiwan, R.O.C.
 TEL: 886-2-8601-3788 / FAX : 886-2-8601-3789
 E-Mail : service@quietek.com

FCC Accreditation Number: TW1014



2. Peak Power Output

2.1. Test Equipment

	Equipment	Manufacturer	Model No./Serial No.	Last Cal.
X	Power Meter	Anritsu	ML2495A/6K00003357	May, 2010
X	Power Sensor	Anritsu	MA2411B/0738448	Jun, 2010

Note: 1. All equipments are calibrated every one year.
 2. The test instruments marked by “X” are used to measure the final test results.

2.2. Test Setup

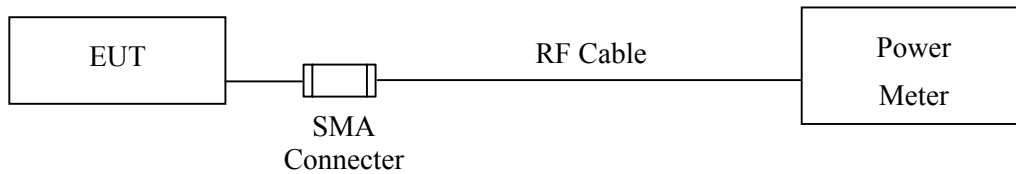

2.3. Limit

The maximum peak power shall be less 1Watt.

2.4. Test Procedure

The EUT was setup to ANSI C63.4, 2003; tested to FHSS test procedure of FCC Public Notice DA 00-705 for compliance to FCC 47CFR 15.247 requirements.

2.5. Uncertainty

± 1.27 dB

2.6. Test Result of Peak Power Output

Product : Motorola Bluetooth Keyboard
Test Item : Peak Power Output
Test Site : No.3 OATS
Test Mode : Mode 1: Transmit - 1Mbps (GFSK)

Channel No.	Frequency (MHz)	Measurement (dBm)	Required Limit	Result
Channel 00	2402.00	-2.60	1 Watt= 30 dBm	Pass
Channel 39	2441.00	-2.40	1 Watt= 30 dBm	Pass
Channel 78	2480.00	-2.30	1 Watt= 30 dBm	Pass

3. Radiated Emission

3.1. Test Equipment

The following test equipments are used during the radiated emission test:

Test Site		Equipment	Manufacturer	Model No./Serial No.	Last Cal.
☒ Site # 3	X	Bilog Antenna	Schaffner Chase	CBL6112B/2673	Sep., 2010
	X	Horn Antenna	Schwarzbeck	BBHA9120D/D305	Sep., 2010
	X	Horn Antenna	Schwarzbeck	BBHA9170/208	Jul., 2010
	X	Pre-Amplifier	QTK	AP-180C/CHM 0906076	Sep., 2010
	X	Spectrum Analyzer	Agilent	E4407B / US39440758	May, 2010
	X	Test Receiver	R & S	ESCS 30/ 825442/018	Sep., 2010
	X	Coaxial Cable	QuiieTek	QTK-CABLE/ CAB5	Feb., 2010
	X	Controller	QuiieTek	QTK-CONTROLLER/ CTRL3	N/A
	X	Coaxial Switch	Anritsu	MP59B/6200265729	N/A

- Note: 1. All equipments are calibrated every one year.
 2. The test instruments marked by "X" are used to measure the final test results.

3.2. Test Setup

Below 1GHz

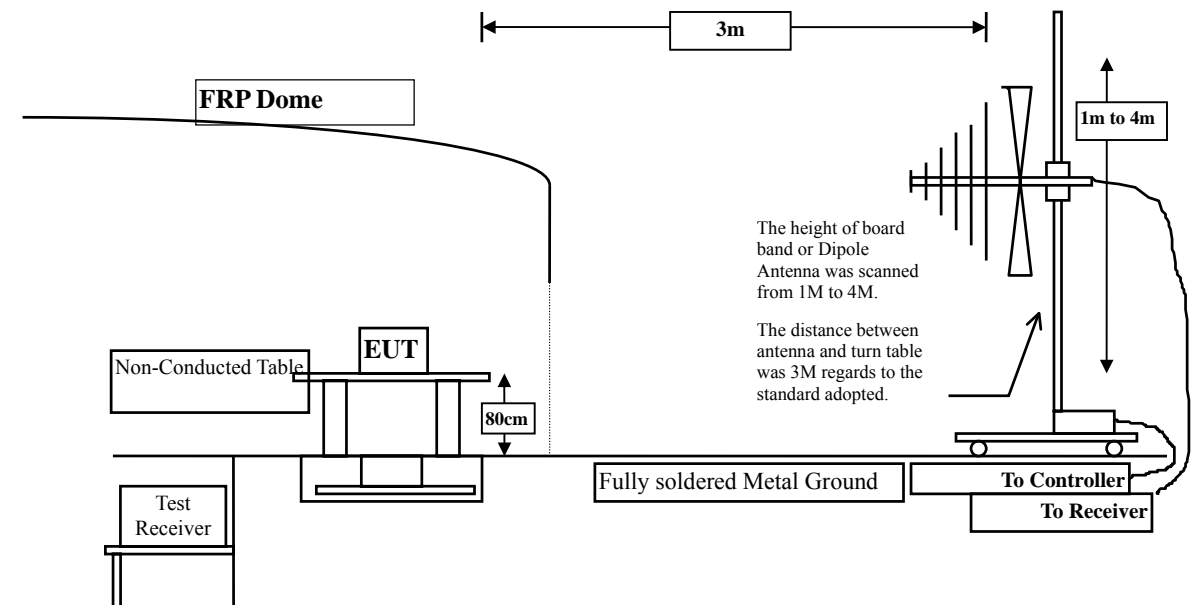

Above 1GHz

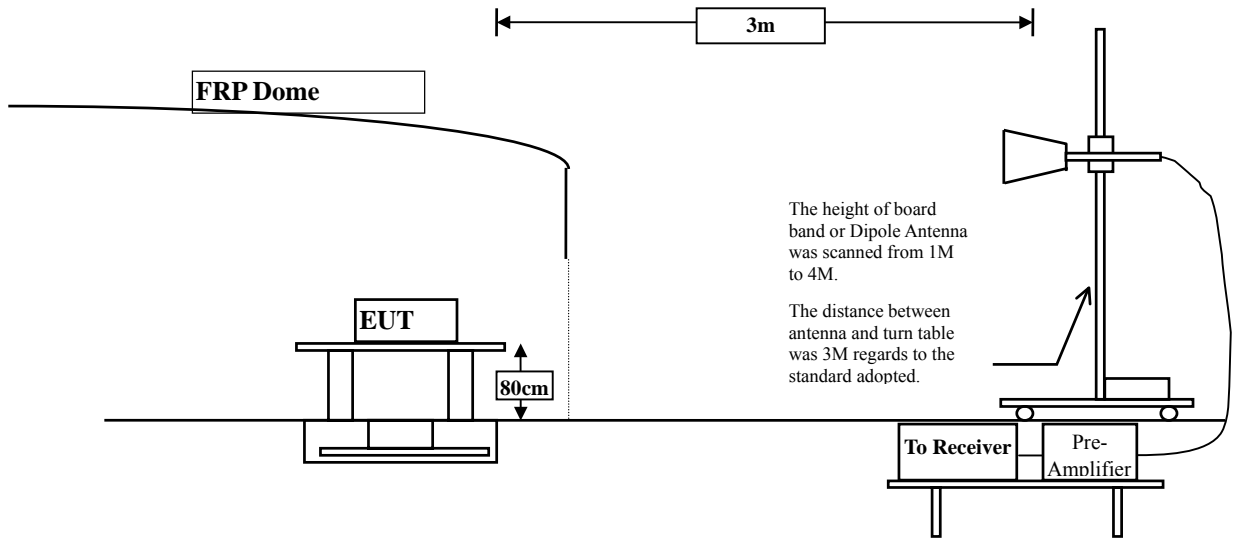

3.3. Limits

➤ General Radiated Emission Limits

Emissions radiated outside of the specified frequency bands, except for harmonics, shall be attenuated by at least 20dB below the level of the fundamental or to the general radiated emission limits in paragraph 15.209, whichever is the lesser attenuation.

FCC Part 15 Subpart C Paragraph 15.209 Limits		
Frequency MHz	uV/m @3m	dBuV/m@3m
30-88	100	40
88-216	150	43.5
216-960	200	46
Above 960	500	54

- Remarks:
1. RF Voltage (dBuV) = 20 log RF Voltage (uV)
 2. In the Above Table, the tighter limit applies at the band edges.
 3. Distance refers to the distance in meters between the measuring instrument antenna and the closed point of any part of the device or system.

3.4. Test Procedure

The EUT was setup according to ANSI C63.4, 2003 and tested according to FHSS test procedure of FCC Public Notice DA 00-705 for compliance to FCC 47CFR 15.247 requirements.

The EUT is placed on a turn table which is 0.8 meter above ground. The turn table is rotated 360 degrees to determine the position of the maximum emission level. The EUT was positioned such that the distance from antenna to the EUT was 3 meters.

The antenna is scanned from 1 meter to 4 meters to find out the maximum emission level. This is repeated for both horizontal and vertical polarization of the antenna. In order to find the maximum emission, all of the interface cables were manipulated according to ANSI C63.4:2003 on radiated measurement.

The resolution bandwidth below 1GHz setting on the field strength meter is 120 kHz and above 1GHz is 1MHz.

Radiated emission measurements below 1GHz are made using broadband Bilog antenna and above 1GHz are made using Horn Antennas.

The measurement is divided into the Preliminary Measurement and the Final Measurement.

The suspected frequencies are searched for in Preliminary Measurement with the measurement antenna kept pointed at the source of the emission both in azimuth and elevation, with the polarization of the antenna oriented for maximum response. The antenna is pointed at an angle towards the source of the emission, and the EUT is rotated in both height and polarization to maximize the measured emission. The emission is kept within the illumination area of the 3 dB beamwidth of the antenna.

The worst radiated emission is measured on the Final Measurement.

The frequency range from 30MHz to 10th harmonics is checked.

3.5. Uncertainty

± 3.9 dB above 1GHz

± 3.8 dB below 1GHz

3.6. Test Result of Radiated Emission

Product : Motorola Bluetooth Keyboard
 Test Item : Harmonic Radiated Emission
 Test Site : No.3 OATS
 Test Mode : Mode 1: Transmit - 1Mbps (GFSK)(2402MHz)

Frequency MHz	Correct Factor dB	Reading Level dBuV	Measurement Level dBuV/m	Margin dB	Limit dBuV/m
Horizontal					
Peak Detector:					
4804.000	3.327	48.890	52.217	-21.783	74.000
7206.000	10.136	40.100	50.236	-23.764	74.000
9608.000	13.706	34.830	48.536	-25.464	74.000
Average Detector:					
--					
Vertical					
Peak Detector:					
4804.000	6.638	45.400	52.037	-21.963	74.000
7206.000	11.005	39.710	50.715	-23.285	74.000
9608.000	14.103	34.260	48.363	-25.637	74.000
Average Detector:					
--					

Note:

1. All Readings below 1GHz are Quasi-Peak, above are performed with peak and/or average measurements as necessary.
2. Receiver setting (Peak Detector) : RBW:1MHz; VBW:1MHz; Span:100MHz ◦
3. Receiver setting (AVG Detector) : RBW:1MHz; VBW:10Hz; Span:20MHz ◦
4. Emission Level = Reading Level + Correct Factor.
5. The average measurement was not performed when the peak measured data under the limit of average detection. If the readings given are average, peak measurement should also be supplied.

Product : Motorola Bluetooth Keyboard
 Test Item : Harmonic Radiated Emission
 Test Site : No.3 OATS
 Test Mode : Mode 1: Transmit - 1Mbps (GFSK)(2441MHz)

Frequency MHz	Correct Factor dB	Reading Level dBuV	Measurement Level dBuV/m	Margin dB	Limit dBuV/m
Horizontal					
Peak Detector:					
4882.000	3.001	50.460	53.461	-20.539	74.000
7323.000	11.846	39.350	51.197	-22.803	74.000
9764.000	12.563	35.550	48.113	-25.887	74.000
Average Detector:					
--					
Vertical					
Peak Detector:					
4882.000	5.713	43.310	49.024	-24.976	74.000
7323.000	12.727	38.300	51.028	-22.972	74.000
9764.000	13.028	35.920	48.948	-25.052	74.000
Average Detector:					
--					

Note:

1. All Readings below 1GHz are Quasi-Peak, above are performed with peak and/or average measurements as necessary.
2. Receiver setting (Peak Detector) : RBW:1MHz; VBW:1MHz; Span:100MHz ◦
3. Receiver setting (AVG Detector) : RBW:1MHz; VBW:10Hz; Span:20MHz ◦
4. Emission Level = Reading Level + Correct Factor.
5. The average measurement was not performed when the peak measured data under the limit of average detection. If the readings given are average, peak measurement should also be supplied.

Product : Motorola Bluetooth Keyboard
 Test Item : Harmonic Radiated Emission
 Test Site : No.3 OATS
 Test Mode : Mode 1: Transmit - 1Mbps (GFSK)(2480MHz)

Frequency MHz	Correct Factor dB	Reading Level dBuV	Measurement Level dBuV/m	Margin dB	Limit dBuV/m
Horizontal					
Peak Detector:					
4960.000	2.760	51.940	54.700	-19.300	74.000
7440.000	12.567	42.340	54.906	-19.094	74.000
9920.000	13.456	35.130	48.586	-25.414	74.000
Average					
Detector:					
4960.000	2.760	49.190	51.950	-2.050	54.000
7440.000	12.567	35.340	47.906	-6.094	54.000
Vertical					
Peak Detector:					
4960.000	5.557	45.540	51.097	-22.903	74.000
7440.000	13.426	38.750	52.175	-21.825	74.000
9920.000	13.958	34.930	48.888	-25.112	74.000
Average					
Detector:					
--					

Note:

1. All Readings below 1GHz are Quasi-Peak, above are performed with peak and/or average measurements as necessary.
2. Receiver setting (Peak Detector) : RBW:1MHz; VBW:1MHz; Span:100MHz ◦
3. Receiver setting (AVG Detector) : RBW:1MHz; VBW:10Hz; Span:20MHz ◦
4. Emission Level = Reading Level + Correct Factor.
5. The average measurement was not performed when the peak measured data under the limit of average detection. If the readings given are average, peak measurement should also be supplied.

Product : Motorola Bluetooth Keyboard
 Test Item : General Radiated Emission
 Test Site : No.3 OATS
 Test Mode : Mode 1: Transmit - 1Mbps (GFSK) (2441MHz)

Frequency MHz	Correct Factor dB	Reading Level dBuV	Measurement Level dBuV/m	Margin dB	Limit dBuV/m
Horizontal					
144.460	-7.703	41.300	33.597	-9.903	43.500
312.270	-4.650	40.987	36.337	-9.663	46.000
419.940	-0.254	39.143	38.889	-7.111	46.000
527.610	3.093	37.452	40.545	-5.455	46.000
719.670	3.822	35.894	39.716	-6.284	46.000
768.170	5.103	35.975	41.079	-4.921	46.000
Vertical					
144.460	-5.503	33.629	28.126	-15.374	43.500
288.020	-5.487	32.920	27.433	-18.567	46.000
384.050	-0.122	32.109	31.987	-14.013	46.000
527.610	1.153	31.569	32.722	-13.278	46.000
768.170	2.383	30.680	33.064	-12.936	46.000
960.230	3.189	26.228	29.417	-24.583	54.000

Note:

1. All Readings below 1GHz are Quasi-Peak, above are performed with peak and/or average measurements as necessary.
2. "█" means the worst emission level.
3. Measurement Level = Reading Level + Correct Factor.
4. The radiated emissions below 1GHz of the lowest, middle, highest frequency are pretested. Only the worst case is shown on the report.

4. RF Antenna Conducted Test

4.1. Test Equipment

	Equipment	Manufacturer	Model No./Serial No.	Last Cal.
	Spectrum Analyzer	R&S	FSP40 / 100170	Jun, 2010
	Spectrum Analyzer	Agilent	E4407B / US39440758	Jun, 2010
X	Spectrum Analyzer	Agilent	N9010A / MY48030495	Apr., 2010

Note: 1. All equipments are calibrated every one year.
 2. The test instruments Marked “X” are used to measure the final test results.

4.2. Test Setup

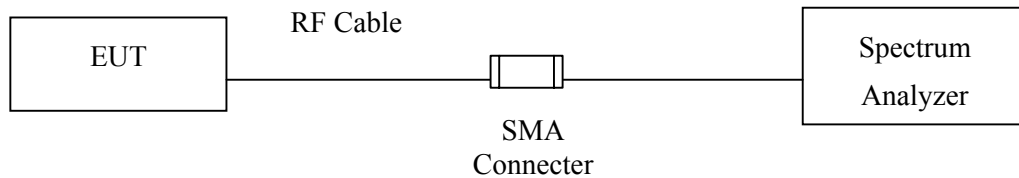

4.3. Limits

According to FCC Section 15.247(d). In any 100 kHz bandwidth outside the frequency band in which the spread spectrum or digitally modulated intentional radiator is operating, the radio frequency power that is produced by the intentional radiator shall be at least 20 dB below that in the 100 kHz bandwidth within the band that contains the highest level of the desired power, based on either an RF conducted or measurement, provided the transmitter demonstrates compliance with the peak conducted power limits. If the transmitter complies with the conducted power limits based on the use of RMS averaging over a time interval, the attenuation required under this paragraph shall be 30 dB instead of 20 dB.

4.4. Test Procedure

The EUT was setup to ANSI C63.4, 2003; tested to FHSS test procedure of FCC Public Notice DA 00-705 for compliance to FCC 47CFR 15.247 requirements.

4.5. Uncertainty

± 150Hz

4.6. Test Result of RF Antenna Conducted Test

Product : Motorola Bluetooth Keyboard
 Test Item : RF Antenna Conducted Test
 Test Site : No.3 OATS
 Test Mode : Mode 1: Transmit - 1Mbps (GFSK)

Figure Channel 00: 30MHz-25GHz

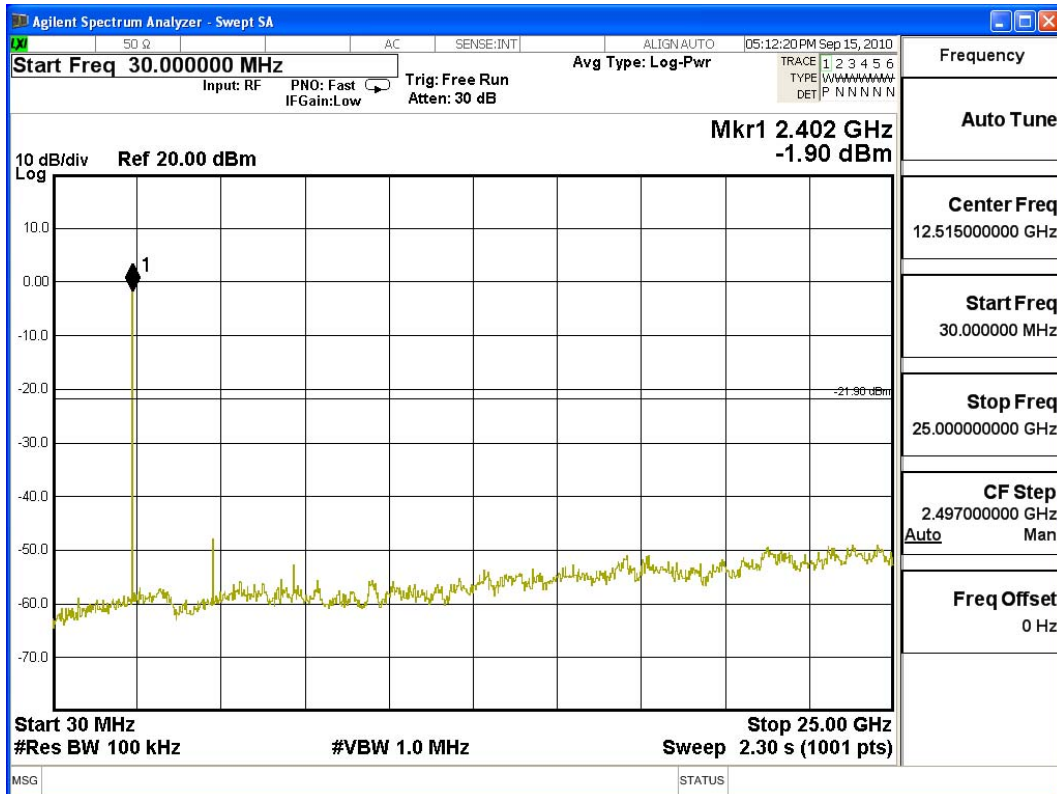

Product : Motorola Bluetooth Keyboard
 Test Item : RF Antenna Conducted Test
 Test Site : No.3 OATS
 Test Mode : Mode 1: Transmit - 1Mbps (GFSK)

Figure Channel 39: 30MHz-25GHz

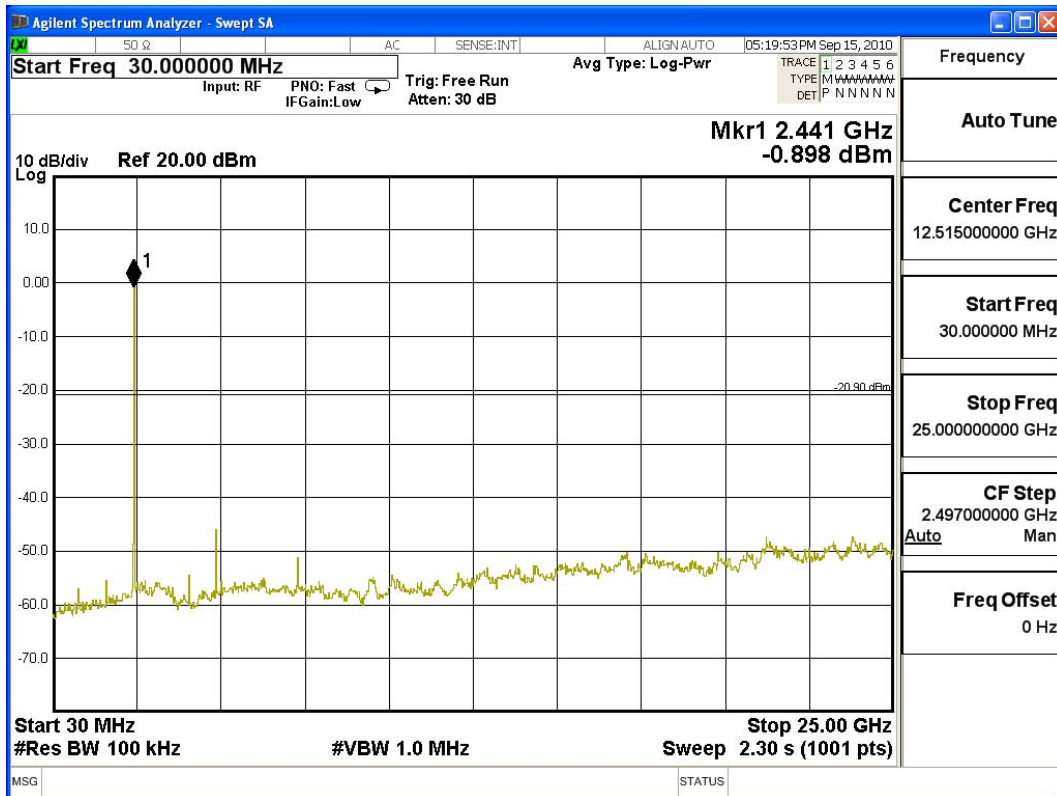

Product : Motorola Bluetooth Keyboard
 Test Item : RF Antenna Conducted Test
 Test Site : No.3 OATS
 Test Mode : Mode 1: Transmit - 1Mbps (GFSK)

Figure Channel 78: 30MHz-25GHz

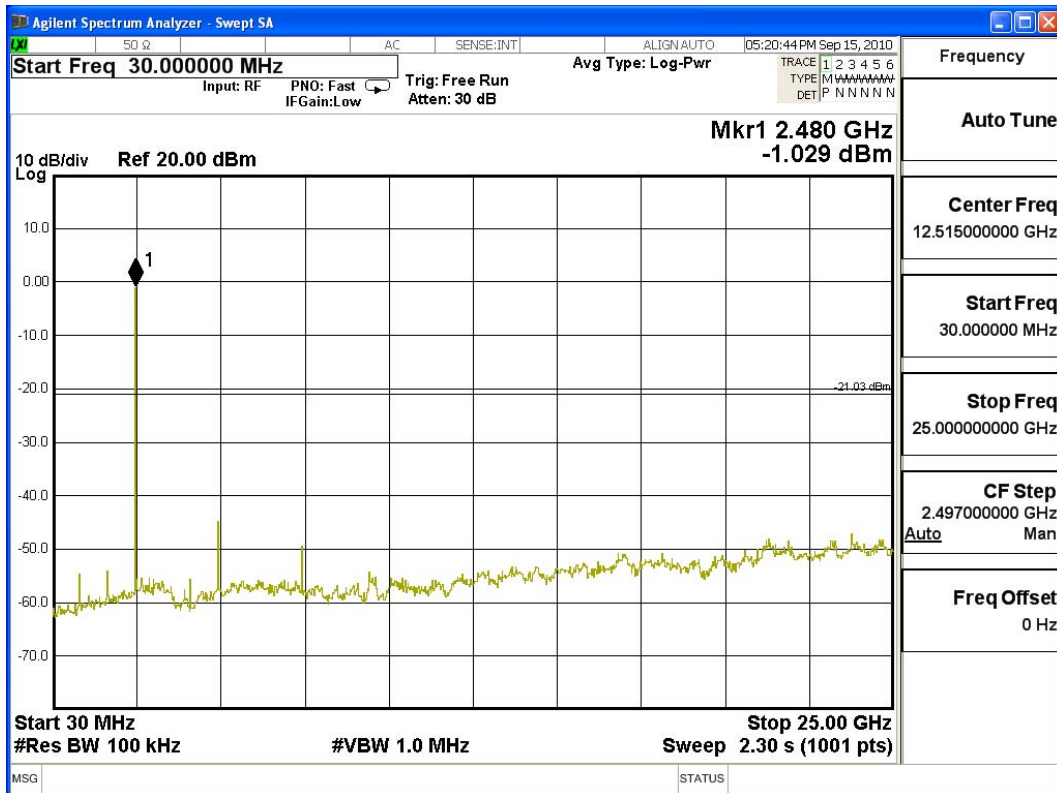

5. Band Edge

5.1. Test Equipment

RF Conducted Measurement

The following test equipments are used during the band edge tests:

	Equipment	Manufacturer	Model No./Serial No.	Last Cal.
	Spectrum Analyzer	R&S	FSP40 / 100170	Jun, 2010
	Spectrum Analyzer	Agilent	E4407B / US39440758	Jun, 2010
X	Spectrum Analyzer	Agilent	N9010A / MY48030495	Apr., 2010

RF Radiated Measurement:

The following test equipments are used during the band edge tests:

Test Site		Equipment	Manufacturer	Model No./Serial No.	Last Cal.
☒ Site # 3		Bilog Antenna	Schaffner Chase	CBL6112B/2673	Sep., 2010
	X	Horn Antenna	Schwarzbeck	BBHA9120D/D305	Sep., 2010
		Horn Antenna	Schwarzbeck	BBHA9170/208	Jul., 2010
	X	Pre-Amplifier	QTK	AP-180C/CHM 0906076	Sep., 2010
	X	Spectrum Analyzer	Agilent	E4407B / US39440758	May, 2010
		Test Receiver	R & S	ESCS 30/ 825442/018	Sep., 2010
	X	Coaxial Cable	Quietek	QTK-CABLE/ CAB5	Feb., 2010
	X	Controller	Quietek	QTK-CONTROLLER/ CTRL3	N/A
	X	Coaxial Switch	Anritsu	MP59B/6200265729	N/A

- Note:
1. All equipments are calibrated every one year.
 2. The test instruments marked by "X" are used to measure the final test results.

5.2. Test Setup

RF Conducted Measurement

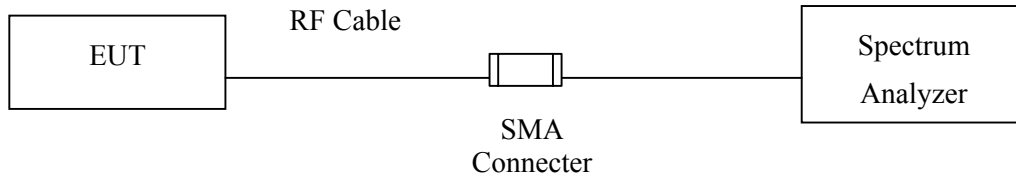

RF Radiated Measurement:

Above 1GHz

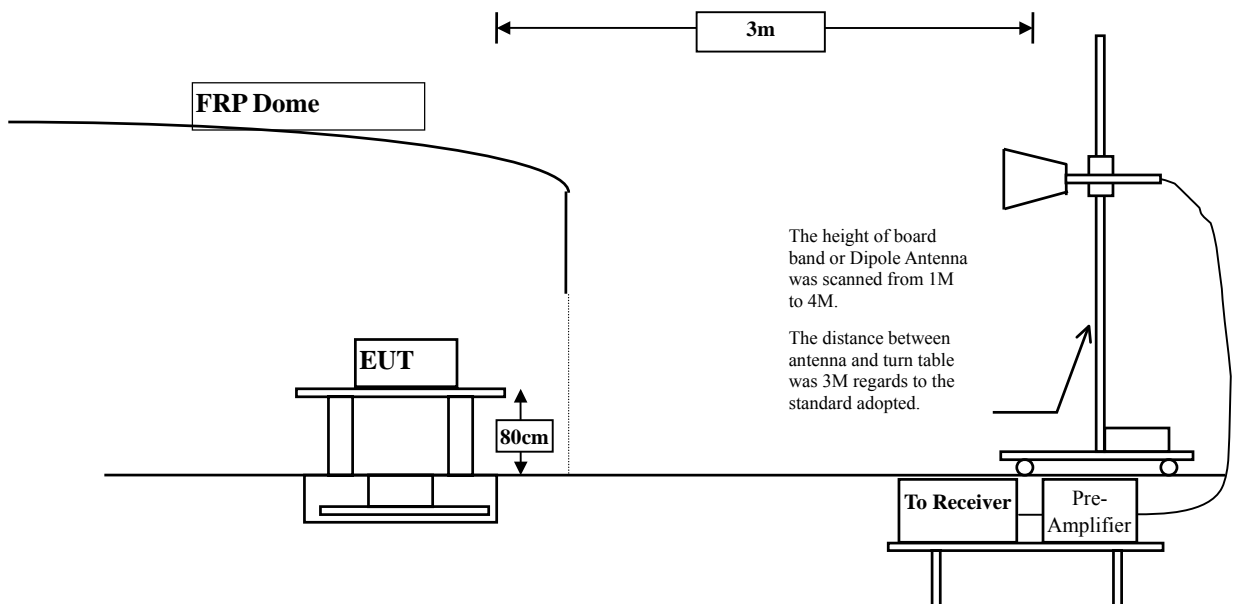

5.3. Limit

In any 100 kHz bandwidth outside the frequency band in which the spread spectrum intentional radiator is operating, the radio frequency power that is produced by the intentional radiator shall be at least 20 dB below that in the 100 kHz bandwidth within the band that contains the highest level of the desired power, based on either an RF conducted or a radiated measurement. Attenuation below the general limits specified in Section 15.209(a) is not required. In addition, radiated emissions which fall in the restricted bands, as defined in Section 15.205(a), must also comply with the radiated emission limits specified in Section 15.209(a) (see Section 15.205(c)).

5.4. Test Procedure

The EUT and its simulators are placed on a turn table which is 0.8 meter above ground. The turn table can rotate 360 degrees to determine the position of the maximum emission level. The EUT was positioned such that the distance from antenna to the EUT was 3 meters.

The antenna can move up and down between 1 meter and 4 meters to find out the maximum emission level.

Both horizontal and vertical polarization of the antenna are set on measurement. In order to find the maximum emission, all of the interface cables must be manipulated according to ANSI C63.4:2003 on radiated measurement.

The bandwidth below 1GHz setting on the field strength meter is 120 kHz, above 1GHz are 1 MHz. The EUT was setup to ANSI C63.4, 2003; tested to FHSS test procedure of FCC Public Notice DA 00-705 for compliance to FCC 47CFR 15.247 requirements.

5.5. Uncertainty

± 3.9 dB above 1GHz

± 3.8 dB below 1GHz

5.6. Test Result of Band Edge

Product : Motorola Bluetooth Keyboard
 Test Item : Band Edge
 Test Site : No.3 OATS
 Test Mode : Mode 1: Transmit - 1Mbps (GFSK)

Fundamental Filed Strength

Antenna Pole	Frequency [MHz]	Correction Factor [dB/m]	Reading Level [dBuV]	Emission Level [dBuV/m]	Detector
Horizontal	2402	31.573	57.23	88.804	Peak
Vertical	2402	30.917	63.97	94.887	Peak

Note: 1:Spectrum Analyzer setting:

Peak detector: RBW=1MHz, VBW=1MHz

Average detector: RBW=1MHz, VBW=10Hz

Band Edge Test Data

Antenna Pole	Test Frequency (MHz)	Fundamental (dBuV/m)	Δ (dB)	Band Edge Field Strength (dBuV/m)	Detector
Horizontal	2388.4	88.804	48.583	40.221	Peak
Vertical	2388.4	94.887	48.583	46.304	Peak

Note:

The Band Edge Field Strength was calculated using the Fundamental and Conducted Band Edge measurements per the Marker-Delta Method with the following formula:

Band Edge field Strength = F - Δ

F = Fundamental field Strength (Peak or Average)

Δ = Conducted Band Edge Delta (Peak or Average)

Peak limit = 74dBuV/m, Average limit = 54dBuV/m

Peak Detector of conducted Band Edge Delta

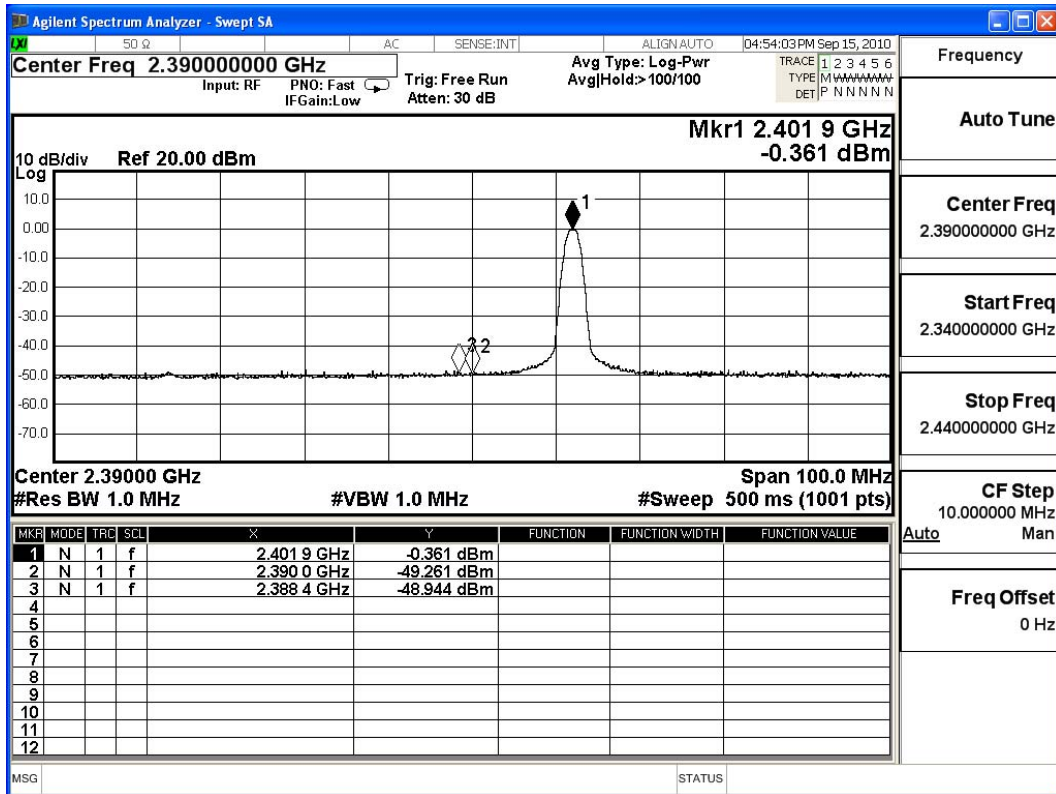

Product : Motorola Bluetooth Keyboard
 Test Item : Band Edge
 Test Site : No.3 OATS
 Test Mode : Mode 1: Transmit - 1Mbps (GFSK)

Fundamental Filed Strength

Antenna Pole	Frequency [MHz]	Correction Factor [dB/m]	Reading Level [dBuV]	Emission Level [dB(uV/m)]	Detector
Horizontal	2480	32.155	57.44	89.596	Peak
Vertical	2480	31.412	63.52	94.932	Peak

Note: 1:Spectrum Analyzer setting:

Peak detector: RBW=1MHz, VBW=1MHz

Average detector: RBW=1MHz, VBW=10Hz

Band Edge Test Data

Antenna Pole	Test Frequency (MHz)	Fundamental (dBuV/m)	Δ (dB)	Band Edge Field Strength (dBuV/m)	Detector
Horizontal	2484.6	89.596	45.197	44.399	Peak
Vertical	2484.6	94.932	45.197	49.735	Peak

Note:

The Band Edge Field Strength was calculated using the Fundamental and Conducted Band Edge measurements per the Marker-Delta Method with the following formula:

Band Edge field Strength = F - Δ

F = Fundamental field Strength (Peak or Average)

Δ = Conducted Band Edge Delta (Peak or Average)

Peak limit = 74dBuV/m, Average limit = 54dBuV/m

Peak Detector of conducted Band Edge Delta

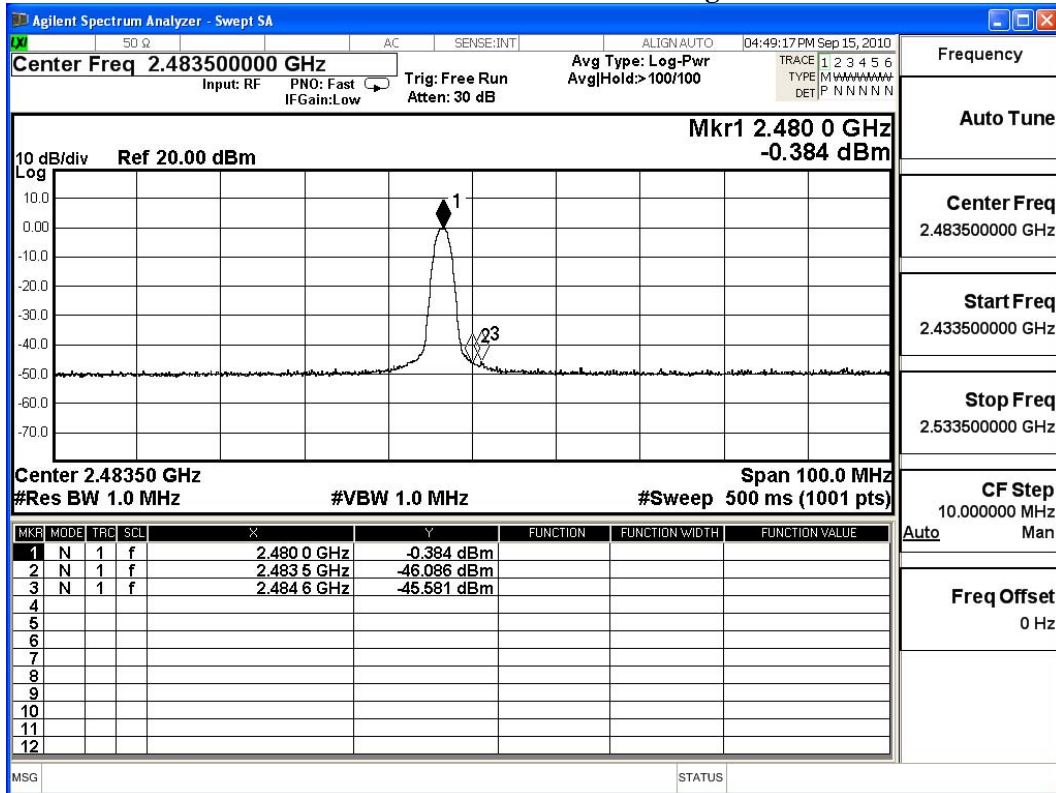

6. Channel Number

6.1. Test Equipment

	Equipment	Manufacturer	Model No./Serial No.	Last Cal.
	Spectrum Analyzer	R&S	FSP40 / 100170	Jun, 2010
	Spectrum Analyzer	Agilent	E4407B / US39440758	Jun, 2010
X	Spectrum Analyzer	Agilent	N9010A / MY48030495	Apr., 2010

Note: 1. All equipments are calibrated every one year.
 2. The test instruments marked by “X” are used to measure the final test results.

6.2. Test Setup

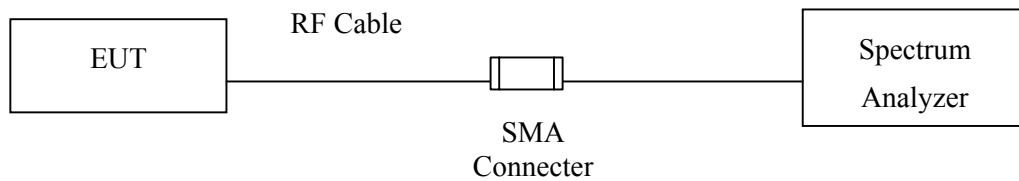

6.3. Limit

Frequency hopping systems operating in the 2400-2483.5 MHz bands shall use at least 75 hopping frequencies.

6.4. Test Procedure

The EUT was setup to ANSI C63.4, 2003; tested to FHSS test procedure of FCC Public Notice DA 00-705 for compliance to FCC 47CFR 15.247 requirements.

6.5. Uncertainty

N/A

6.6. Test Result of Channel Number

Product : Motorola Bluetooth Keyboard
 Test Item : Channel Number
 Test Site : No.3 OATS
 Test Mode : Mode 1: Transmit - 1Mbps (GFSK)

Frequency Range (MHz)	Measurement (Hopping Channel)	Required Limit (Hopping Channel)	Result
2402 ~ 2480	79	>75	Pass

2402-2421MHz

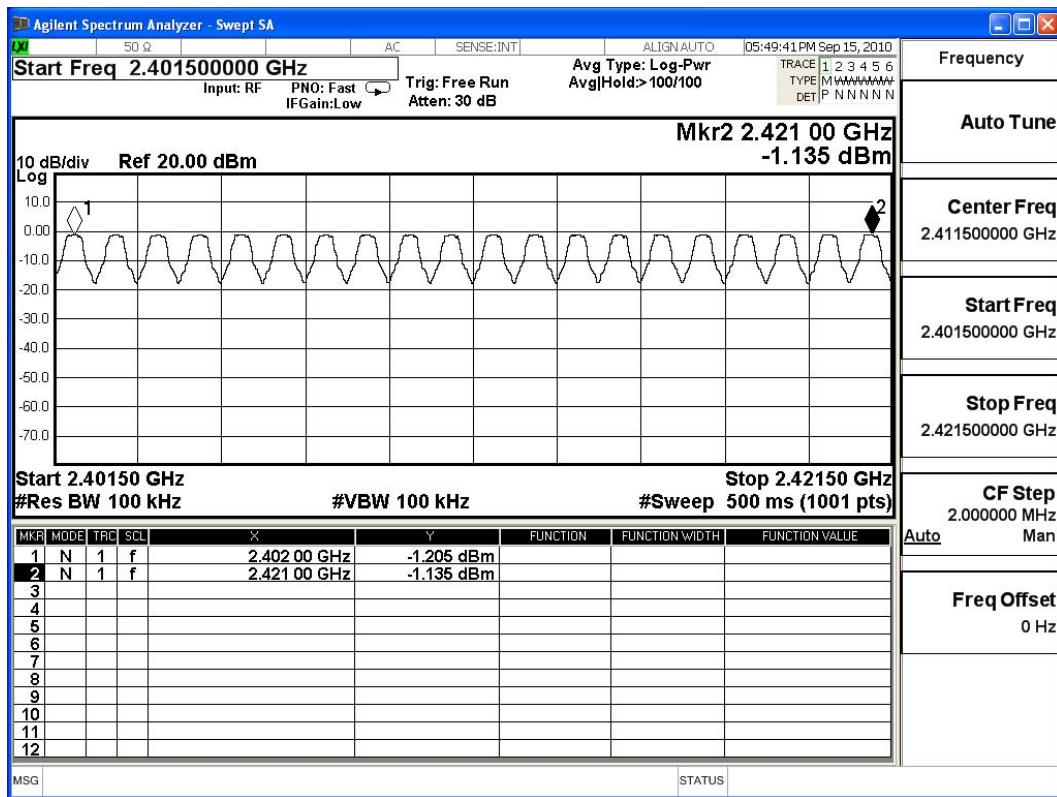

2422-2441MHz

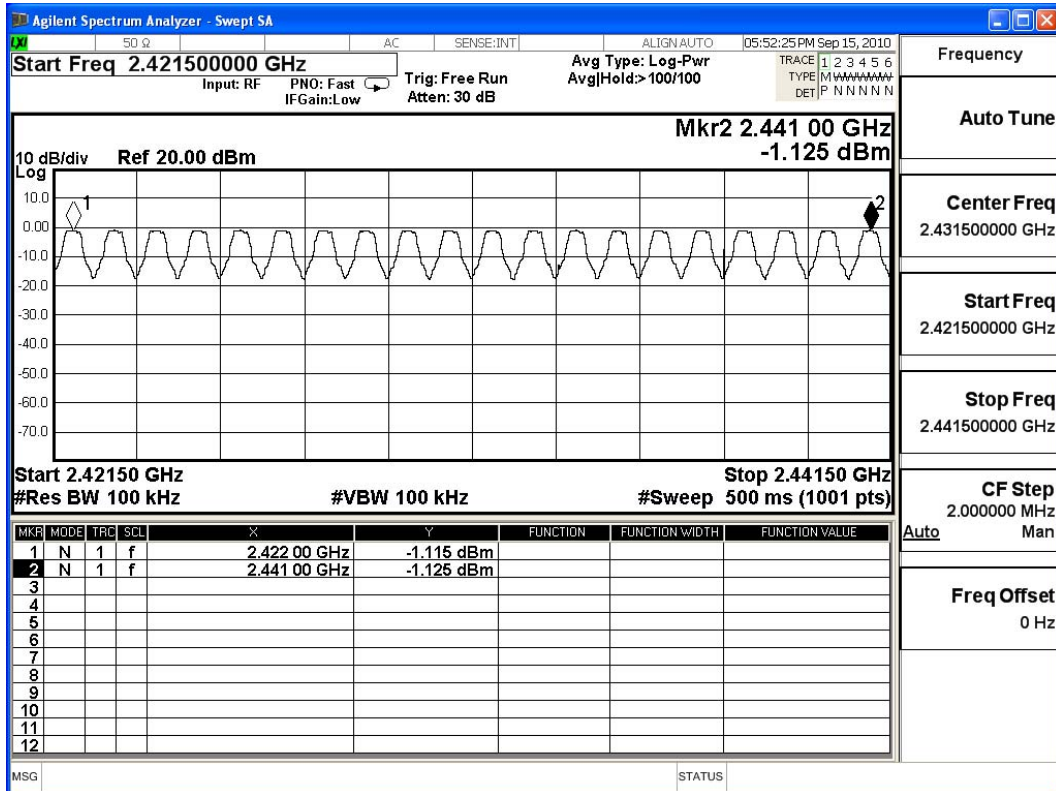

2442-2461MHz

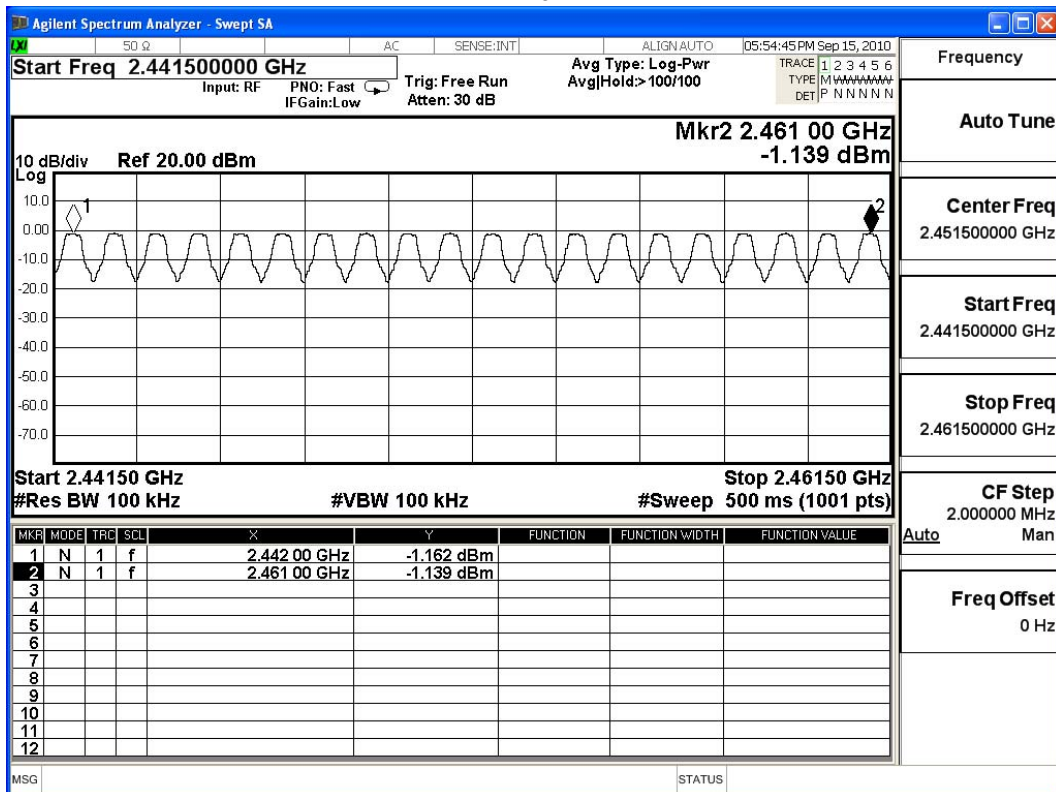

2462-2480MHz

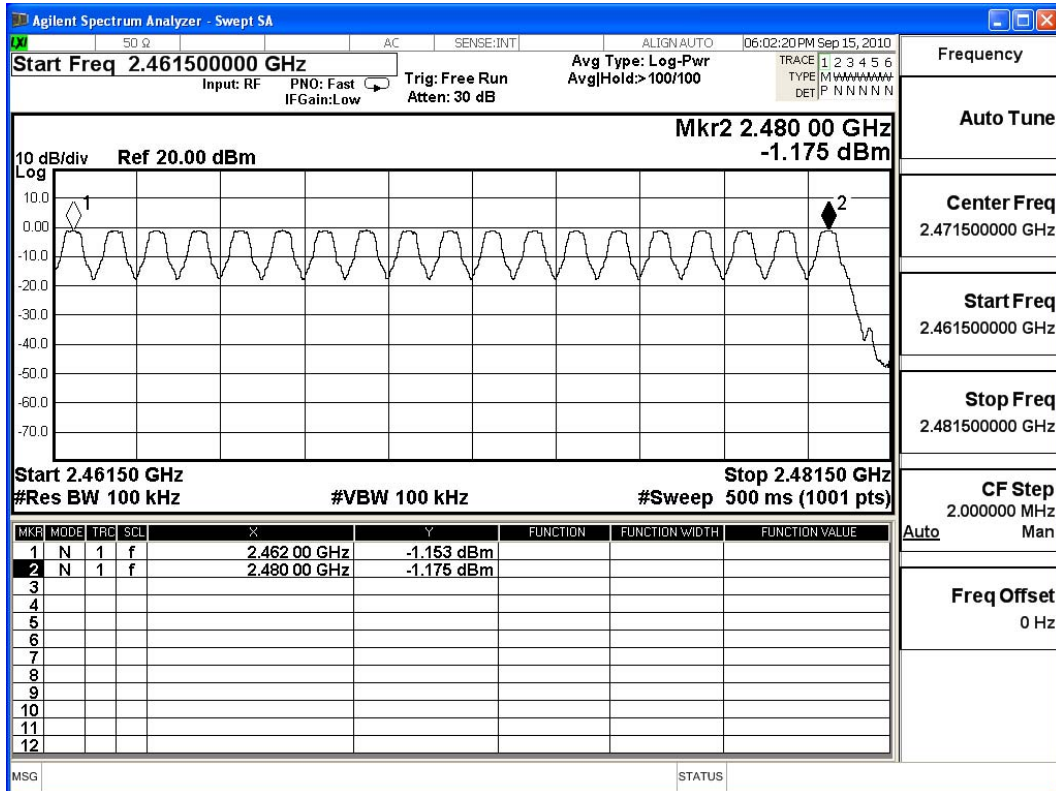

7. Channel Separation

7.1. Test Equipment

	Equipment	Manufacturer	Model No./Serial No.	Last Cal.
	Spectrum Analyzer	R&S	FSP40 / 100170	Jun, 2010
	Spectrum Analyzer	Agilent	E4407B / US39440758	Jun, 2010
X	Spectrum Analyzer	Agilent	N9010A / MY48030495	Apr., 2010

- Note:
1. All equipments are calibrated every one year.
 2. The test instruments mark by “X” are used to measure the final test results.

7.2. Test Setup

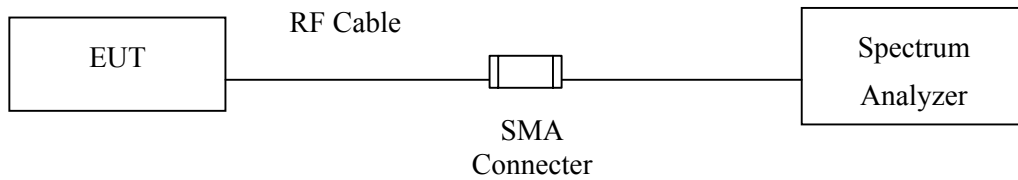

7.3. Limit

Frequency hopping systems shall have hopping channel carrier frequencies separated by a minimum of 25 kHz or the 20 dB bandwidth of the hopping channel, whichever is greater.

7.4. Test Procedure

The EUT was setup to ANSI C63.4, 2003; tested to FHSS test procedure of FCC Public Notice DA 00-705 for compliance to FCC 47CFR 15.247 requirements.

7.5. Uncertainty

± 150Hz

7.6. Test Result of Channel Separation

Product : Motorola Bluetooth Keyboard
 Test Item : Channel Separation
 Test Site : No.3 OATS
 Test Mode : Mode 1: Transmit - 1Mbps (GFSK)

Channel No.	Frequency (MHz)	Measurement Level (kHz)	Limit (kHz)	Limit of (2/3)*20dB Bandwidth (kHz)	Result
00	2402	1000	>25 kHz	753.3	Pass
39	2441	1000	>25 kHz	753.3	Pass
78	2480	1000	>25 kHz	746.7	Pass

NOTE: The 20dB Bandwidth is refer to section 10.

Channel 00 2402MHz

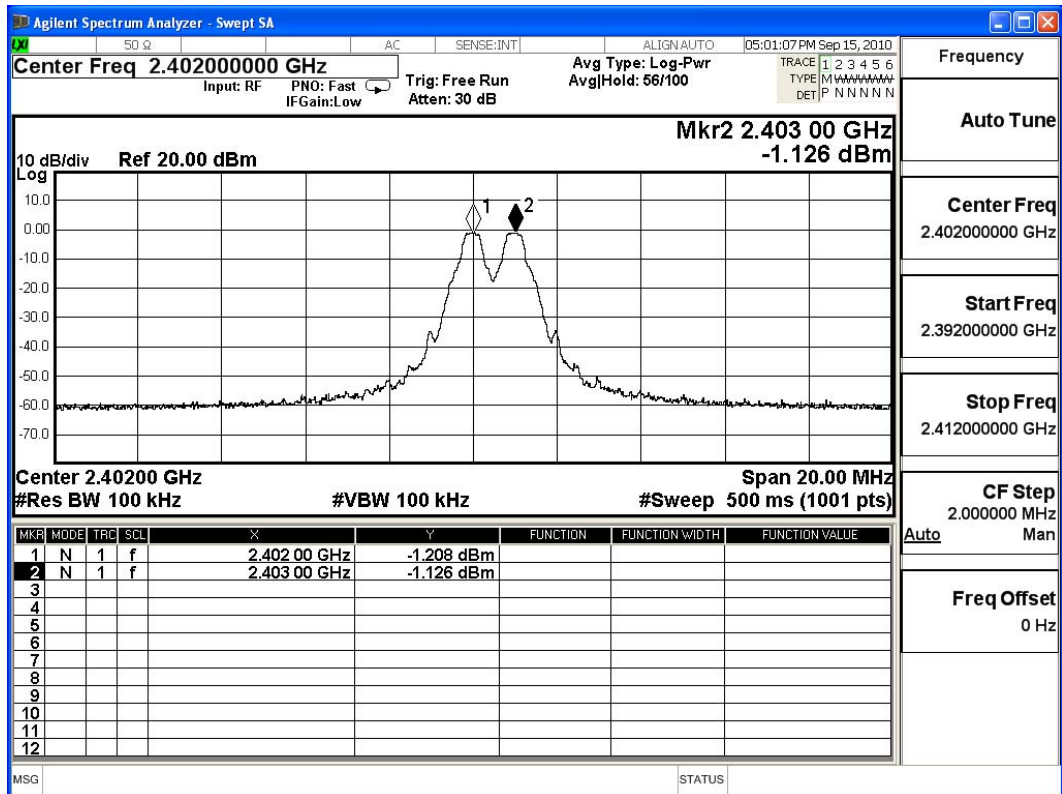

Channel 39 2441MHz

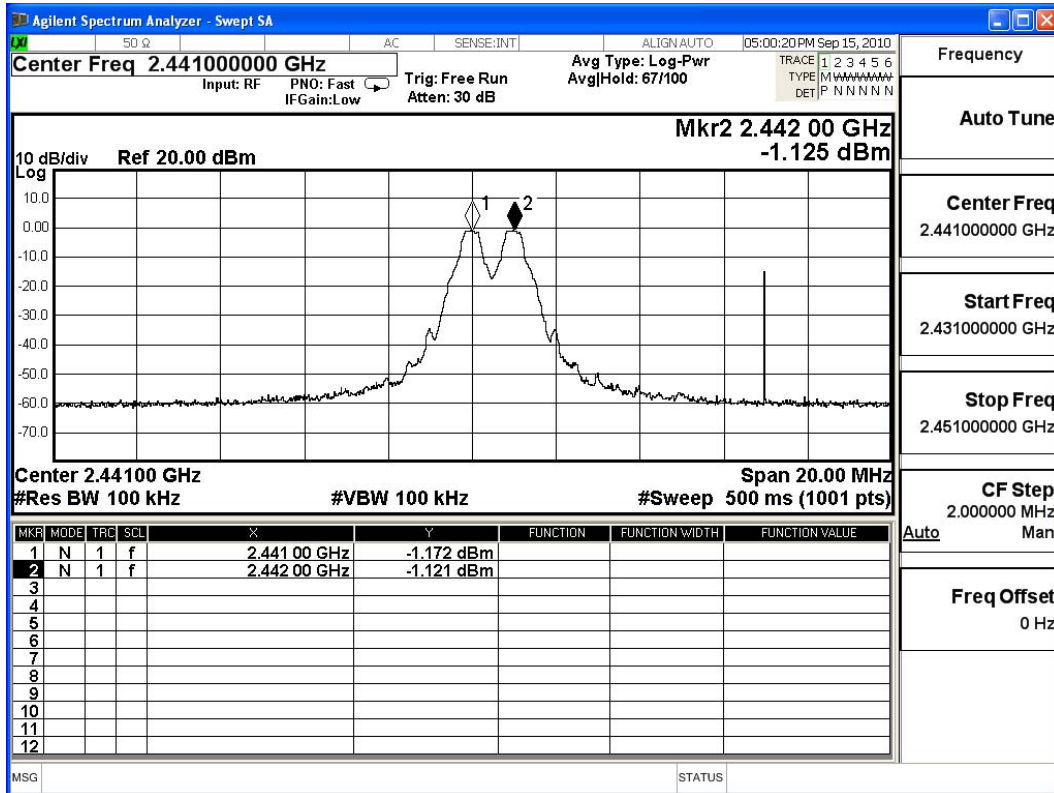

Channel 78 2480 MHz

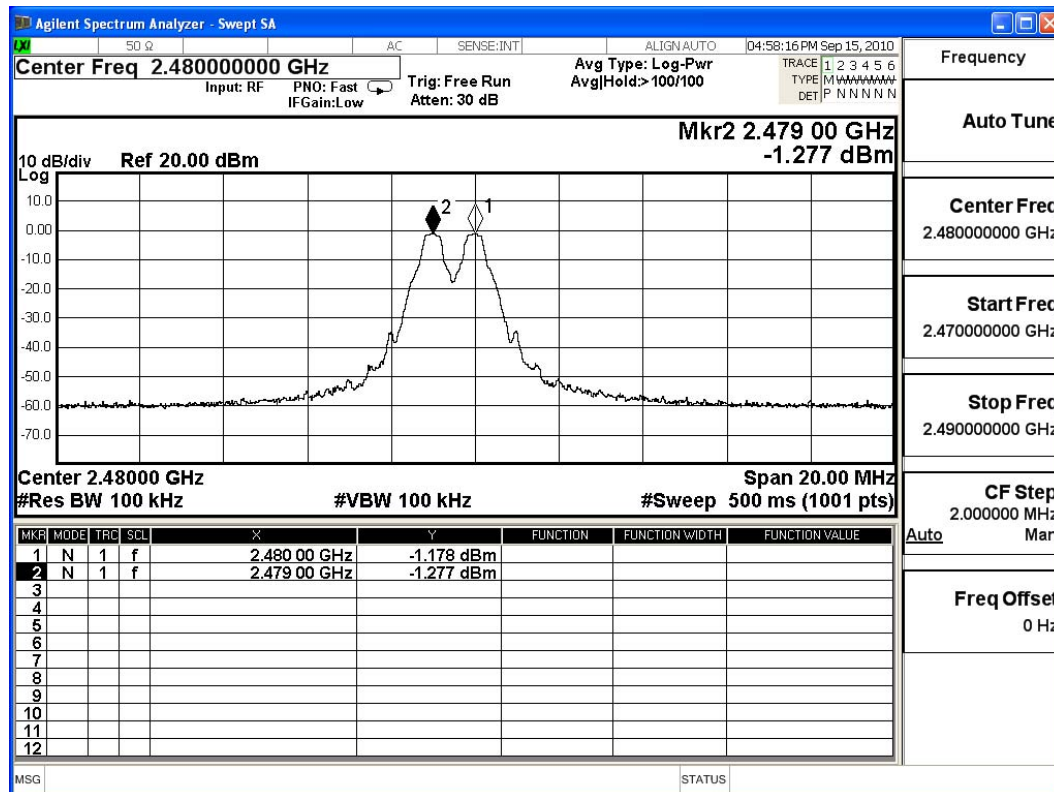

8. Dwell Time

8.1. Test Equipment

	Equipment	Manufacturer	Model No./Serial No.	Last Cal.
	Spectrum Analyzer	R&S	FSP40 / 100170	Jun, 2010
	Spectrum Analyzer	Agilent	E4407B / US39440758	Jun, 2010
X	Spectrum Analyzer	Agilent	N9010A / MY48030495	Apr., 2010

Note: 1. All equipments are calibrated every one year.
 2. The test instruments marked by “X” are used to measure the final test results.

8.2. Test Setup

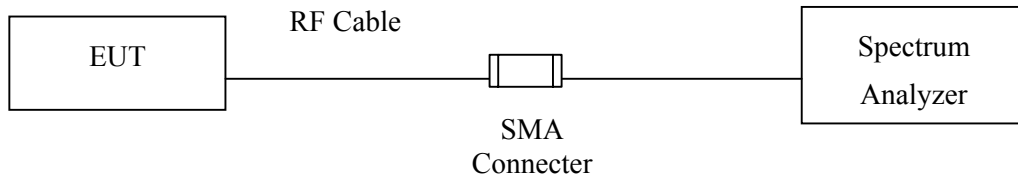

8.3. Limit

The dwell time shall be the average time of occupancy on any frequency shall not be greater than 0.4 seconds within a 30 second period.

8.4. Test Procedure

The EUT was setup to ANSI C63.4, 2003; tested to FHSS test procedure of FCC Public Notice DA 00-705 for compliance to FCC 47CFR 15.247 requirements.

8.5. Uncertainty

± 25msec

8.6. Test Result of Dwell Time

Product : Motorola Bluetooth Keyboard
 Test Item : Dwell Time
 Test Site : No.3 OATS
 Test Mode : Mode 1: Transmit - 1Mbps (GFSK) (Channel 00,39,78 –DH5)

Channel No.	Frequency (MHz)	Time slot length (ms)	Hopping of Number	Sweep time (ms)	Duty cycle	Dwell Time (Sec)	Limit (Sec)	Result
00	2402	2.850	8	30	0.76	0.304	0.4	Pass
39	2441	2.850	8	30	0.76	0.304	0.4	Pass
78	2480	2.850	8	30	0.76	0.304	0.4	Pass

Duty cycle = ((Time slot length(ms)*Hopping of Number) / Sweep time (ms))

Dwell time = (Duty cycle / 79) * (79*0.4)

CH 00 Time Interval between hops

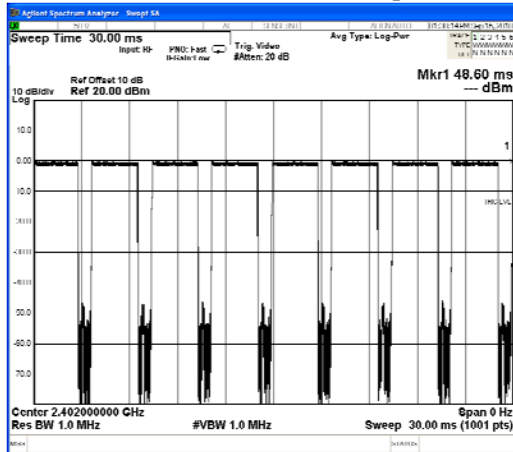

CH 00 Transmission Time

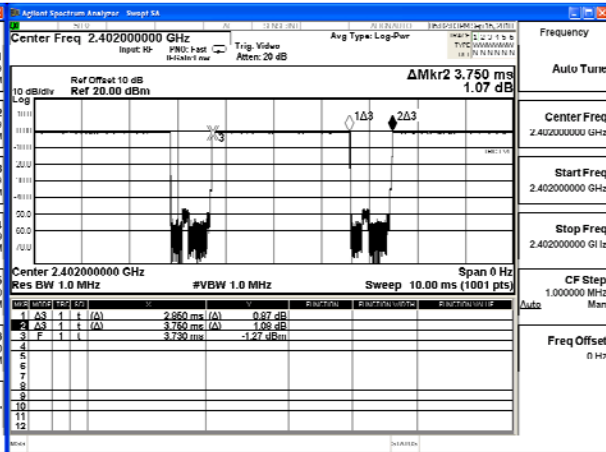

CH39 Time Interval between hops

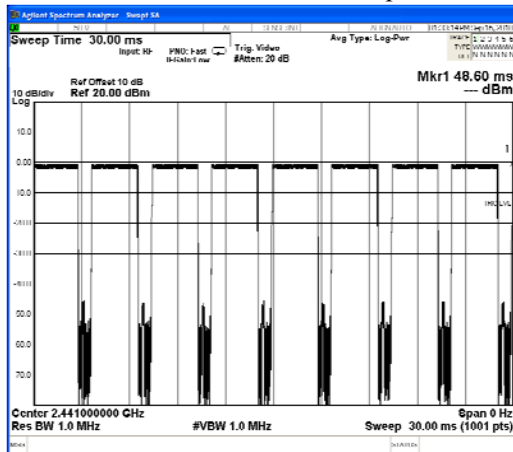

CH 39 Transmission Time

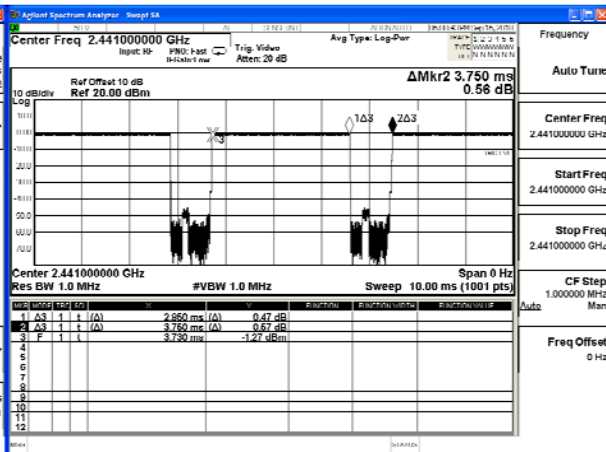

CH 78 Time Interval between hops

CH 78 Transmission Time

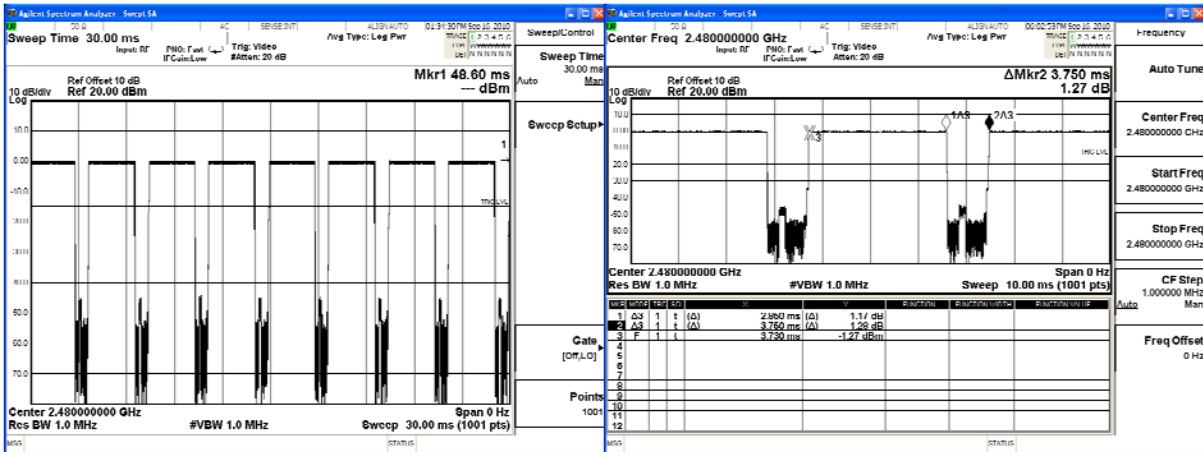

Note:

The dwell times of the packet type of DH1, DH3, and DH5 are tested. Only the worst case is shown on the report.

9. Occupied Bandwidth

9.1. Test Equipment

	Equipment	Manufacturer	Model No./Serial No.	Last Cal.
	Spectrum Analyzer	R&S	FSP40 / 100170	Jun, 2010
	Spectrum Analyzer	Agilent	E4407B / US39440758	Jun, 2010
X	Spectrum Analyzer	Agilent	N9010A / MY48030495	Apr., 2010

Note: 1. All equipments are calibrated every one year.
 2. The test instruments marked by “X” are used to measure the final test results.

9.2. Test Setup

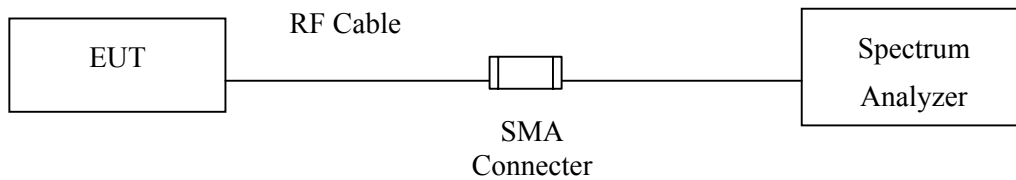

9.3. Limits

N/A

9.4. Test Procedure

The EUT was setup to ANSI C63.4, 2003; tested to FHSS test procedure of FCC Public Notice DA 00-705 for compliance to FCC 47CFR 15.247 requirements.

9.5. Uncertainty

± 150Hz

9.6. Test Result of Occupied Bandwidth

Product : Motorola Bluetooth Keyboard
 Test Item : Occupied Bandwidth Data
 Test Site : No.3 OATS
 Test Mode : Mode 1: Transmit - 1Mbps (GFSK)(2402MHz)

Channel No.	Frequency (MHz)	Measurement Level (kHz)	Required Limit (kHz)	Result
00	2402	1130	--	NA

Figure Channel 00:

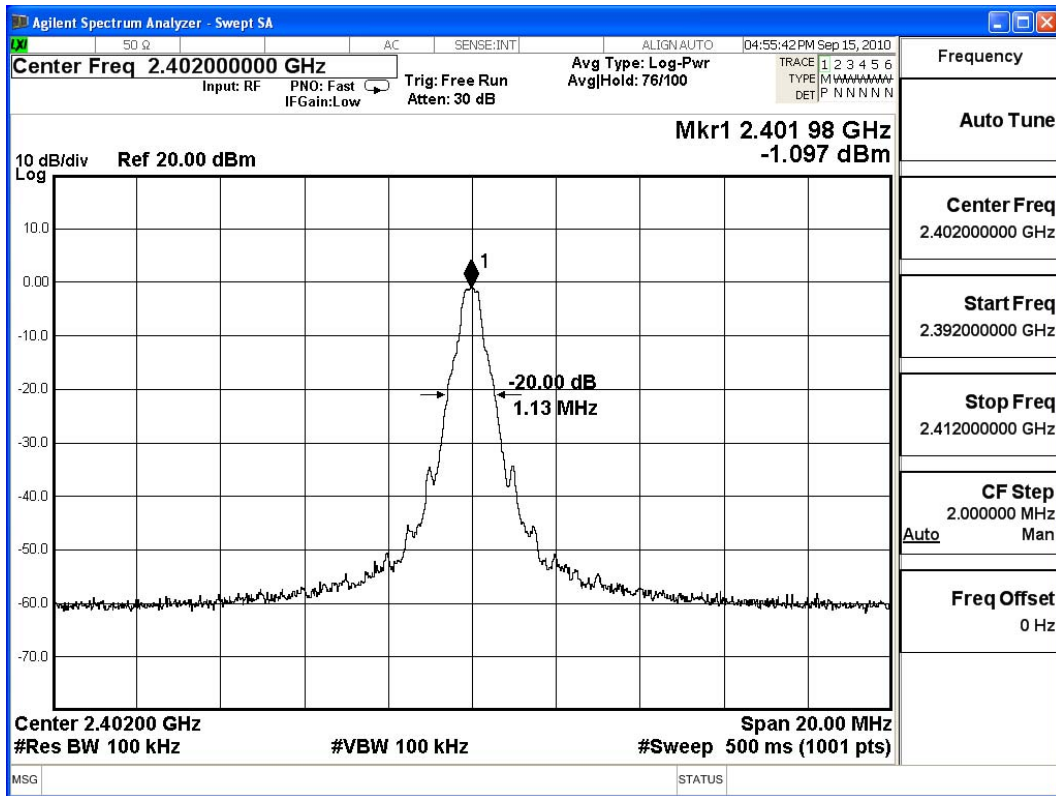

Product : Motorola Bluetooth Keyboard
 Test Item : Occupied Bandwidth Data
 Test Site : No.3 OATS
 Test Mode : Mode 1: Transmit - 1Mbps (GFSK)(2441MHz)

Channel No.	Frequency (MHz)	Measurement Level (kHz)	Required Limit (kHz)	Result
39	2441	1130	--	NA

Figure Channel 39:

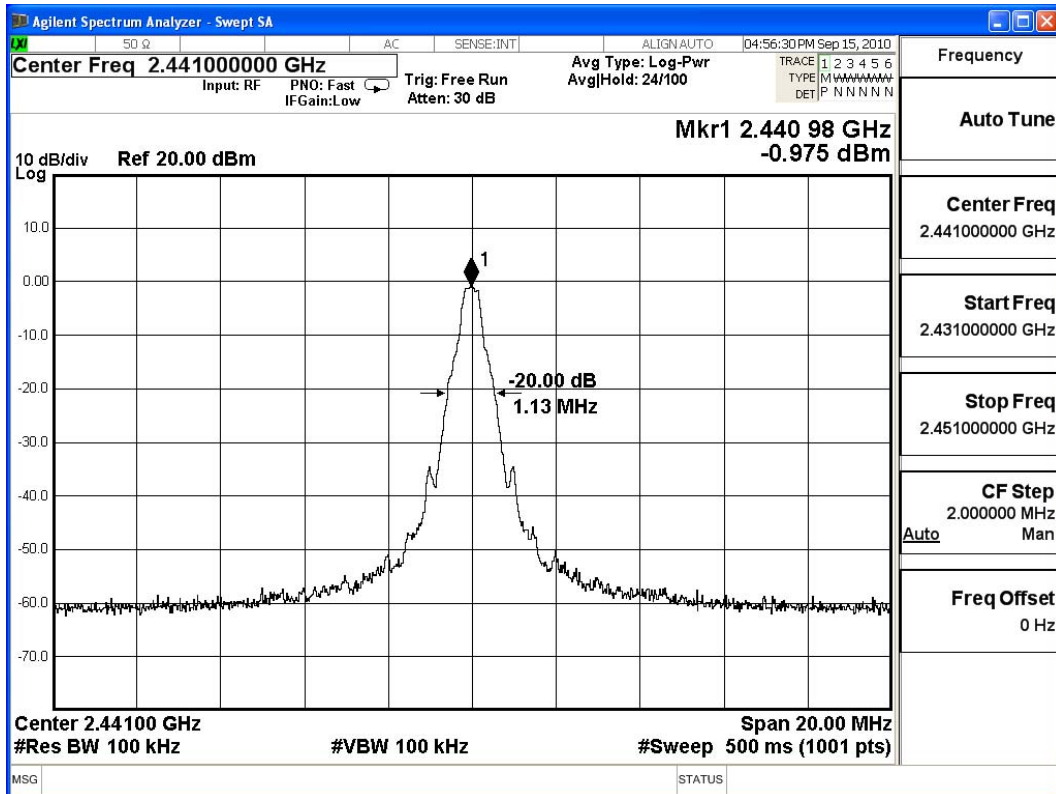

Product : Motorola Bluetooth Keyboard
 Test Item : Occupied Bandwidth Data
 Test Site : No.3 OATS
 Test Mode : Mode 1: Transmit - 1Mbps (GFSK)(2480MHz)

Channel No.	Frequency (MHz)	Measurement Level (kHz)	Required Limit (kHz)	Result
78	2480	1120	--	NA

Figure Channel 78:

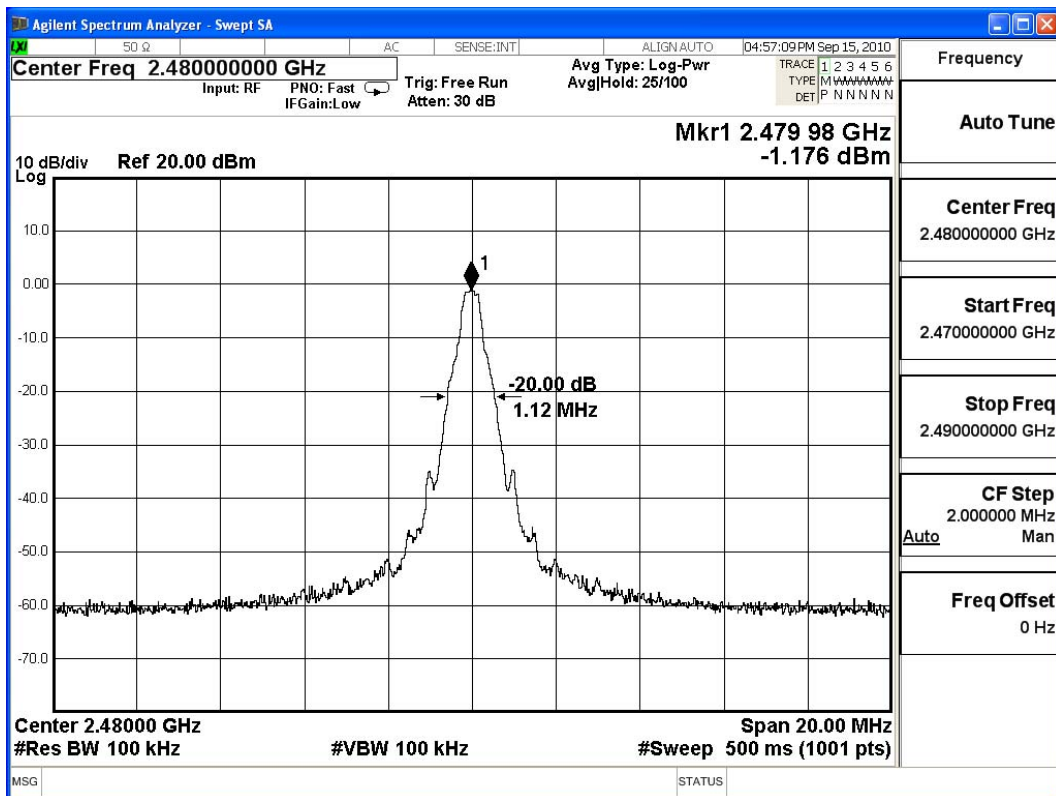

10. EMI Reduction Method During Compliance Testing

No modification was made during testing.