

APPENDIX A: SAR TEST DATA

PCTEST ENGINEERING LABORATORY, INC.

DUT: MB860; Type: Portable Handset with 5 GHz WLAN; Serial: 353648040030974

Communication System: IEEE 802.11a 5.2-5.8 GHz Band; Frequency: 5220 MHz; Duty Cycle: 1:1

Medium: 5 GHz Medium parameters used (interpolated):

$f = 5220 \text{ MHz}$; $\sigma = 5.14 \text{ mho/m}$; $\epsilon_r = 47.8$; $\rho = 1000 \text{ kg/m}^3$

Phantom section: Flat Section; Space 2.5 cm

Test Date: 11-29-2010; Ambient Temp: 23.5 °C; Tissue Temp: 22.3 °C

Probe: EX3DV4 - SN3561; ConvF(3.67, 3.67, 3.67); Calibrated: 8/19/2010

Sensor-Surface: 2mm (Mechanical Surface Detection)

Electronics: DAE4 Sn665; Calibrated: 4/21/2010

Phantom: SAM with CRP; Type: SAM; Serial: TP1375

Measurement SW: DASY4, V4.7 Build 80; Postprocessing SW: SEMCAD, V1.8 Build 186

Mode: WLAN 802.11a 5.2 GHz, Body Back, Ch. 44, 6 Mbps

Area Scan (9x16x1): Measurement grid: dx=10mm, dy=10mm

Zoom Scan (7x7x11)/Cube 0: Measurement grid: dx=4mm, dy=4mm, dz=2mm

Reference Value = 1.90 V/m

Peak SAR (extrapolated) = 0.208 W/kg

SAR(1 g) = 0.037 mW/g; SAR(10 g) = 0.017 mW/g

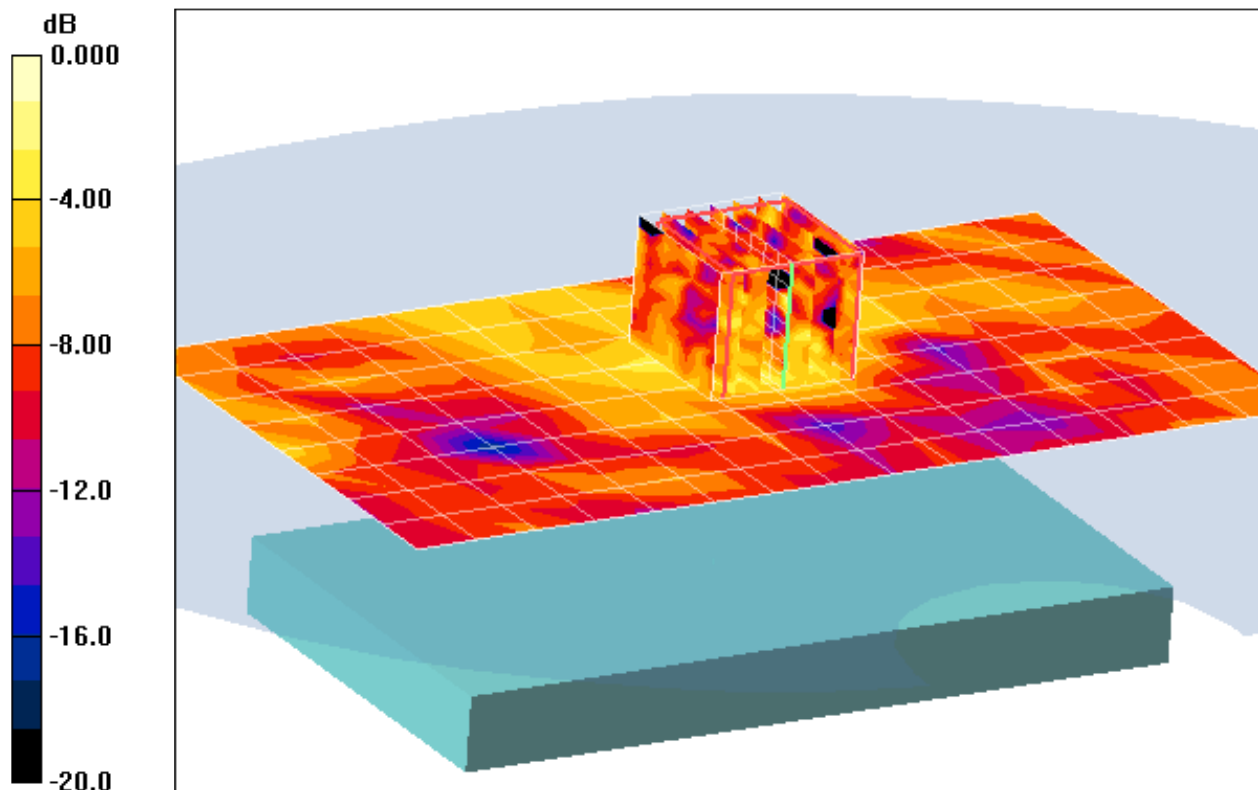

0 dB = 0.093mW/g

PCTEST ENGINEERING LABORATORY, INC.

DUT: MB860; Type: Portable Handset with 5 GHz WLAN; Serial: 353648040030974

Communication System: IEEE 802.11n 5.2-5.8 GHz Band; Frequency: 5180 MHz; Duty Cycle: 1:1

Medium: 5 GHz Medium parameters used (interpolated):

$f = 5180 \text{ MHz}$; $\sigma = 5.104 \text{ mho/m}$; $\epsilon = 48$; $\rho = 1000 \text{ kg/m}^3$

Phantom section: Flat Section; Space 2.5 cm

Test Date: 11-29-2010; Ambient Temp: 23.5 °C; Tissue Temp: 22.3 °C

Probe: EX3DV4 - SN3561; ConvF(3.67, 3.67, 3.67); Calibrated: 8/19/2010

Sensor-Surface: 2mm (Mechanical Surface Detection)

Electronics: DAE4 Sn665; Calibrated: 4/21/2010

Phantom: SAM with CRP; Type: SAM; Serial: TP1375

Measurement SW: DASY4, V4.7 Build 80; Postprocessing SW: SEMCAD, V1.8 Build 186

Mode: WLAN 802.11n 5.2 GHz, Body Front, Ch. 36, 7.2 Mbps

Area Scan (9x16x1): Measurement grid: dx=10mm, dy=10mm

Zoom Scan (7x7x11)/Cube 0: Measurement grid: dx=4mm, dy=4mm, dz=2mm

Reference Value = 1.40 V/m

Peak SAR (extrapolated) = 0.062 W/kg

SAR(1 g) = 0.020 mW/g; SAR(10 g) = 0.013 mW/g

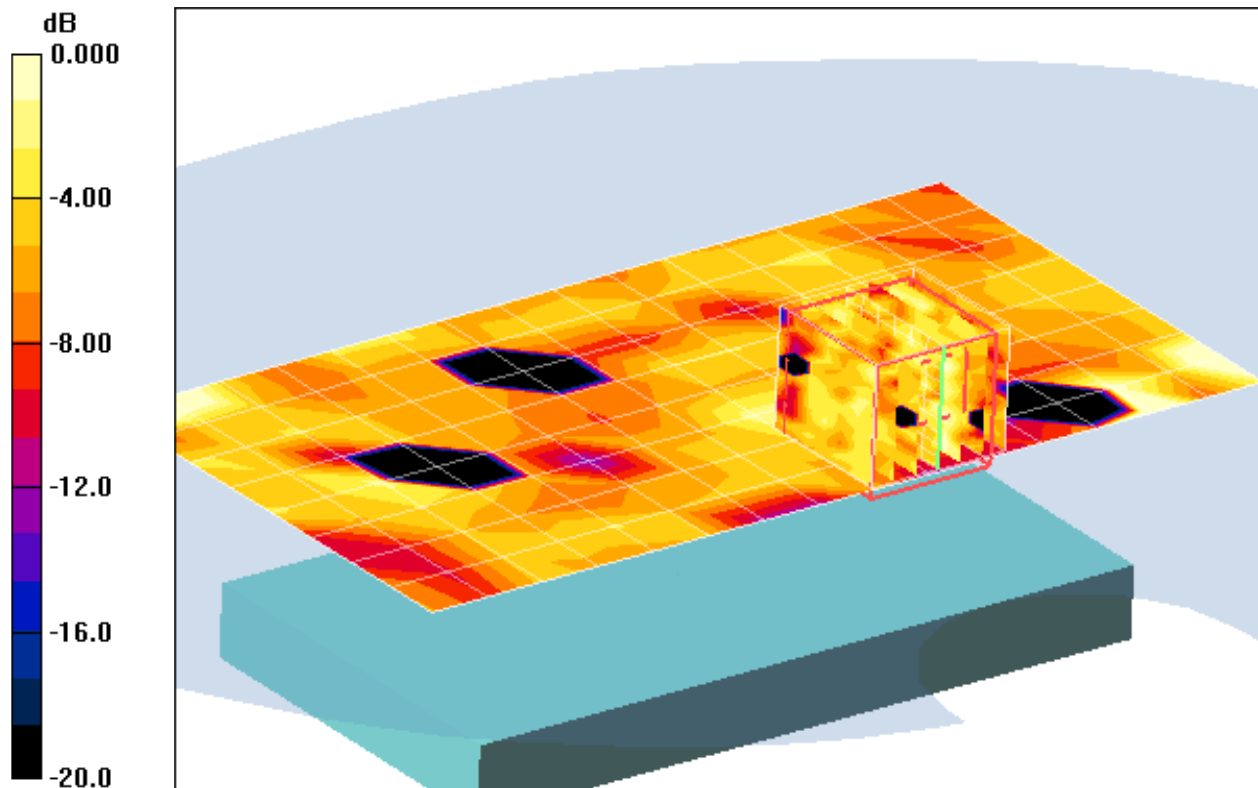

0 dB = 0.040mW/g

PCTEST ENGINEERING LABORATORY, INC.

DUT: MB860; Type: Portable Handset with 5 GHz WLAN; Serial: 353648040030974

Communication System: IEEE 802.11a 5.2-5.8 GHz Band; Frequency: 5240 MHz; Duty Cycle: 1:1

Medium: 5 GHz Medium parameters used (interpolated):

$f = 5240$ MHz; $\sigma = 5.22$ mho/m; $\epsilon_r = 47.8$; $\rho = 1000$ kg/m³

Phantom section: Flat Section; Space: 1.0 cm

Test Date: 11-29-2010; Ambient Temp: 23.5°C; Tissue Temp: 22.3°C

Probe: EX3DV4 - SN3561; ConvF(3.67, 3.67, 3.67); Calibrated: 8/19/2010

Sensor-Surface: 2mm (Mechanical Surface Detection)

Electronics: DAE4 Sn665; Calibrated: 4/21/2010

Phantom: SAM with CRP; Type: SAM; Serial: TP1375

Measurement SW: DASY4, V4.7 Build 80; Postprocessing SW: SEMCAD, V1.8 Build 186

Mode: WLAN 802.11a 5.2 GHz, Body Back, Ch. 48, 6 Mbps

Area Scan (9x16x1): Measurement grid: dx=10mm, dy=10mm

Zoom Scan (7x7x11)/Cube 0: Measurement grid: dx=4mm, dy=4mm, dz=2mm

Reference Value = 2.78 V/m

Peak SAR (extrapolated) = 0.248 W/kg

SAR(1 g) = 0.087 mW/g; SAR(10 g) = 0.037 mW/g

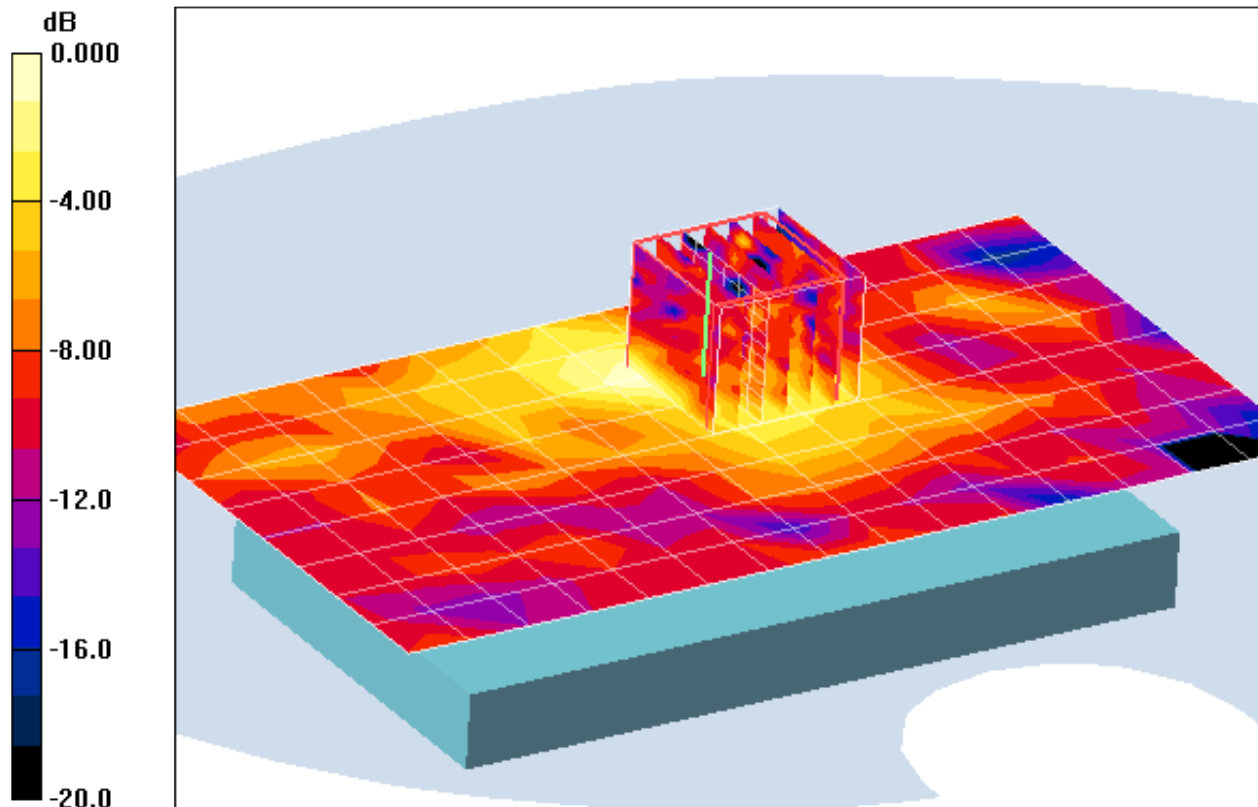

0 dB = 0.150mW/g

PCTEST ENGINEERING LABORATORY, INC.

DUT: MB860; Type: Portable Handset with 5 GHz WLAN; Serial: 353648040030974

Communication System: IEEE 802.11a 5.2-5.8 GHz Band; Frequency: 5240 MHz; Duty Cycle: 1:1

Medium: 5 GHz Medium parameters used (interpolated):

$f = 5240 \text{ MHz}$; $\sigma = 5.22 \text{ mho/m}$; $\epsilon_r = 47.8$; $\rho = 1000 \text{ kg/m}^3$

Phantom section: Flat Section; Space: 1.0 cm

Test Date: 06-14-2003; Ambient Temp: 22.8°C; Tissue Temp: 20.2°C

Probe: EX3DV4 - SN3561; ConvF(3.67, 3.67, 3.67); Calibrated: 8/19/2010

Sensor-Surface: 2mm (Mechanical Surface Detection)

Electronics: DAE4 Sn665; Calibrated: 4/21/2010

Phantom: SAM with CRP; Type: SAM; Serial: TP1375

Measurement SW: DASY4, V4.7 Build 80; Postprocessing SW: SEMCAD, V1.8 Build 186

Mode: WLAN 802.11a 5.2 GHz, Body Back, Ch. 48, 6 Mbps

Area Scan (9x16x1): Measurement grid: dx=10mm, dy=10mm

Zoom Scan (7x7x11)/Cube 0: Measurement grid: dx=4mm, dy=4mm, dz=2mm

Reference Value = 2.78 V/m

Peak SAR (extrapolated) = 0.248 W/kg

SAR(1 g) = 0.087 mW/g; SAR(10 g) = 0.037 mW/g

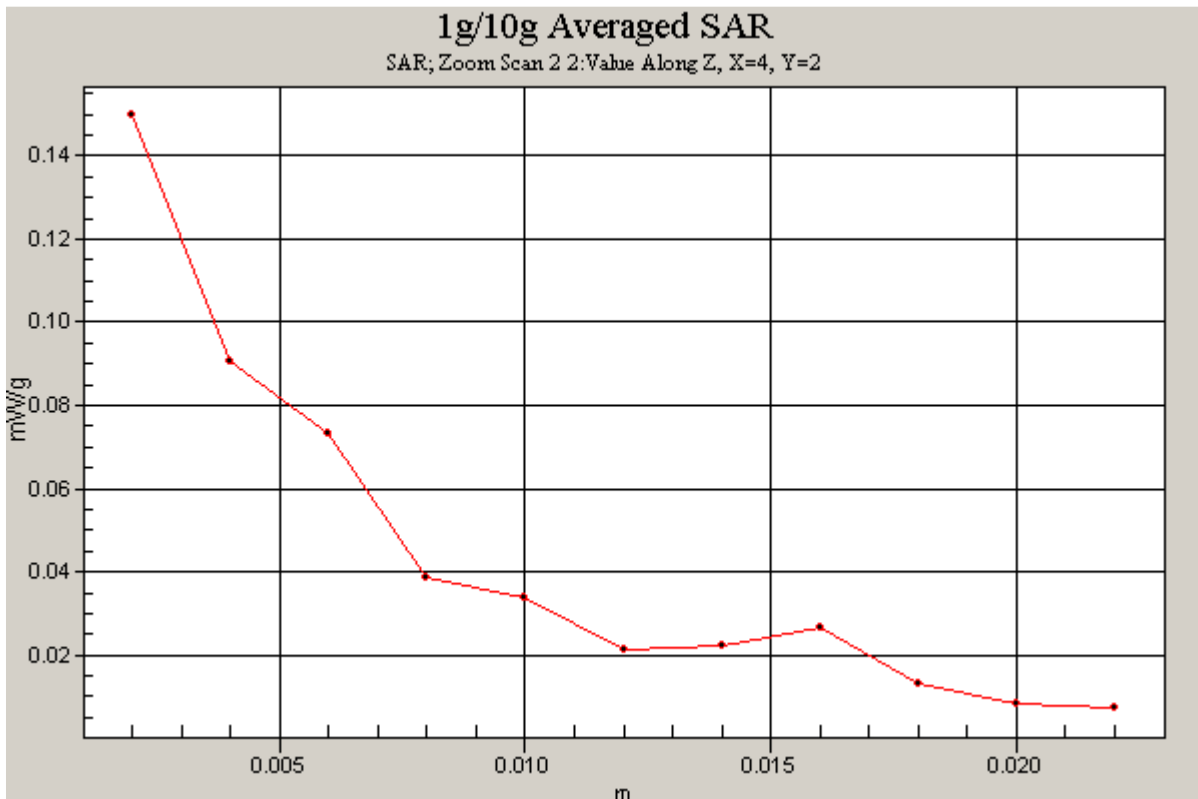

PCTEST ENGINEERING LABORATORY, INC.

DUT: MB860; Type: Portable Handset with 5 GHz WLAN; Serial: 353648040030974

Communication System: IEEE 802.11a 5.2-5.8 GHz Band; Frequency: 5180 MHz; Duty Cycle: 1:1

Medium: 5 GHz Medium parameters used (interpolated):

$f = 5180 \text{ MHz}$; $\sigma = 5.104 \text{ mho/m}$; $\epsilon_r = 48$; $\rho = 1000 \text{ kg/m}^3$

Phantom section: Flat Section; Space: 1.0 cm

Test Date: 11-29-2010; Ambient Temp: 23.5 °C; Tissue Temp: 22.3 °C

Probe: EX3DV4 - SN3561; ConvF(3.67, 3.67, 3.67); Calibrated: 8/19/2010

Sensor-Surface: 2mm (Mechanical Surface Detection)

Electronics: DAE4 Sn665; Calibrated: 4/21/2010

Phantom: SAM with CRP; Type: SAM; Serial: TP1375

Measurement SW: DASY4, V4.7 Build 80; Postprocessing SW: SEMCAD, V1.8 Build 186

Mode: WLAN 802.11n 5.2 GHz, Body Front, Ch. 36, 7.2 Mbps

Area Scan Use for Plots (9x16x1): Measurement grid: dx=10mm, dy=10mm
Zoom Scan (7x7x11)/Cube 0: Measurement grid: dx=4mm, dy=4mm, dz=2mm

Reference Value = 2.30 V/m

Peak SAR (extrapolated) = 0.084 W/kg

SAR(1 g) = 0.028 mW/g; SAR(10 g) = 0.016 mW/g

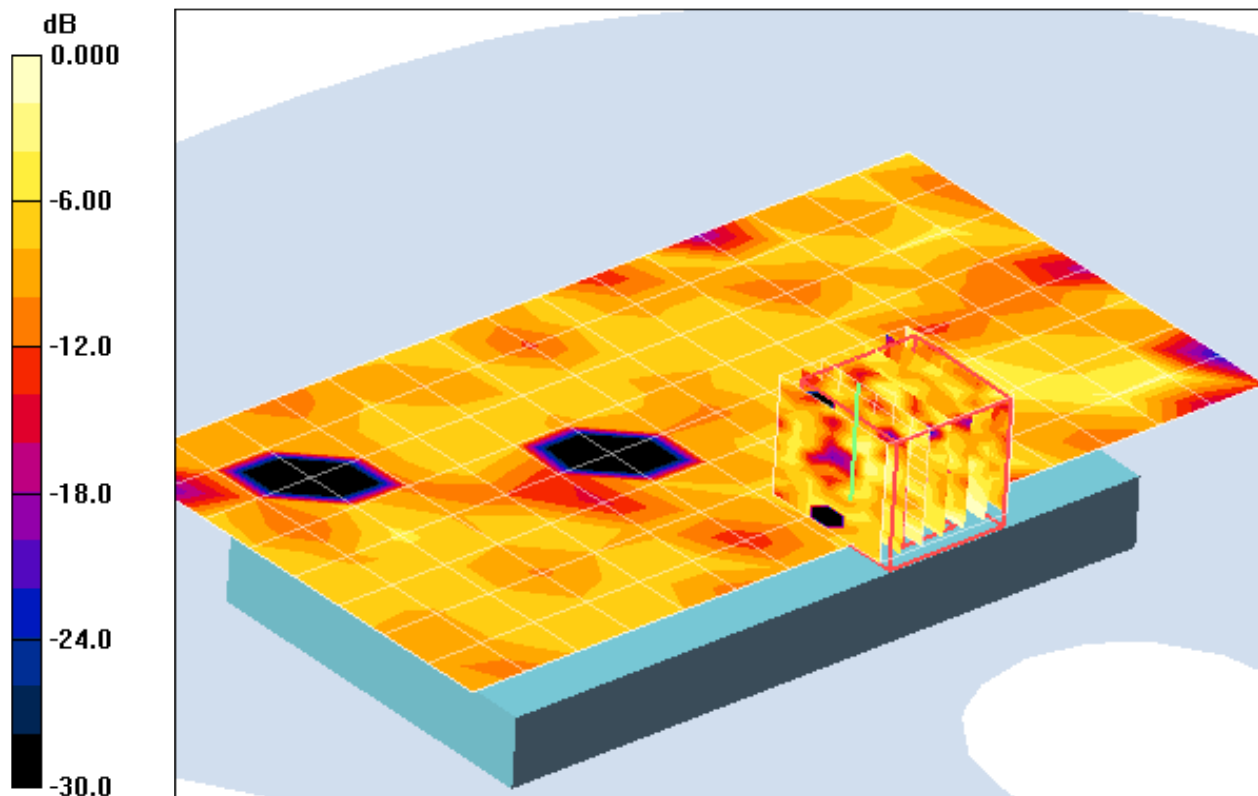

0 dB = 0.060mW/g

PCTEST ENGINEERING LABORATORY, INC.

DUT: MB860; Type: Portable Handset with 5 GHz WLAN; Serial: 353648040030974

Communication System: IEEE 802.11a 5.2-5.8 GHz Band; Frequency: 5240 MHz; Duty Cycle: 1:1

Medium: 5 GHz Medium parameters used (interpolated):

$f = 5240$ MHz; $\sigma = 5.22$ mho/m; $\epsilon_r = 47.8$; $\rho = 1000$ kg/m³

Phantom section: Flat Section; Space: 1.0 cm

Test Date: 06-14-2003; Ambient Temp: 22.8°C; Tissue Temp: 20.2°C

Probe: EX3DV4 - SN3561; ConvF(3.67, 3.67, 3.67); Calibrated: 8/19/2010

Sensor-Surface: 2mm (Mechanical Surface Detection)

Electronics: DAE4 Sn665; Calibrated: 4/21/2010

Phantom: SAM with CRP; Type: SAM; Serial: TP1375

Measurement SW: DASY4, V4.7 Build 80; Postprocessing SW: SEMCAD, V1.8 Build 186

Mode: WLAN 802.11a 5.2 GHz, Body Right, Ch. 48, 6 Mbps

Area Scan (5x16x1): Measurement grid: dx=10mm, dy=10mm

Zoom Scan (7x7x11)/Cube 0: Measurement grid: dx=4mm, dy=4mm, dz=2mm

Reference Value = 4.34 V/m

Peak SAR (extrapolated) = 0.688 W/kg

SAR(1 g) = 0.062 mW/g; SAR(10 g) = 0.033 mW/g

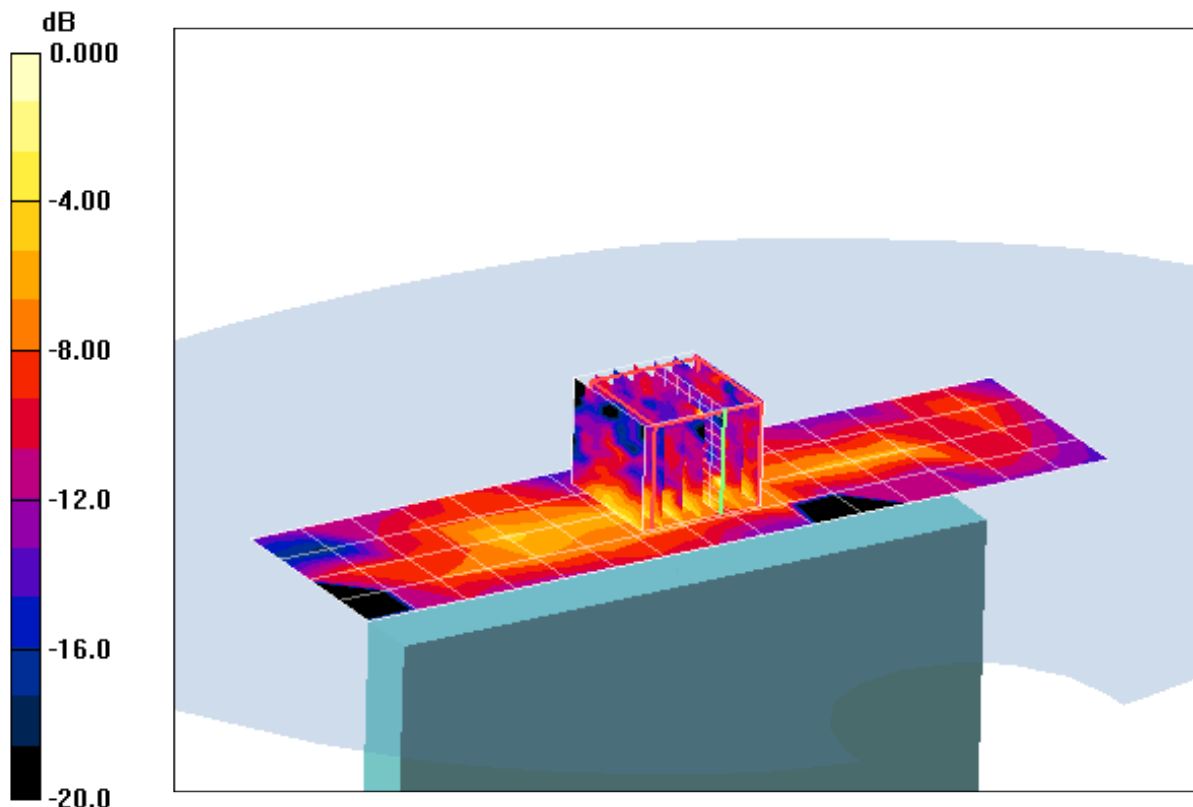

0 dB = 0.249mW/g

PCTEST ENGINEERING LABORATORY, INC.

DUT: MB860; Type: Portable Handset with 5 GHz WLAN; Serial: 353648040030974

Communication System: IEEE 802.11n 5.2-5.8 GHz Band; Frequency: 5745 MHz; Duty Cycle: 1:1

Medium: 5 GHz Medium parameters used (interpolated):

$f = 5745$ MHz; $\sigma = 6.01$ mho/m; $\epsilon_r = 46.4$; $\rho = 1000$ kg/m³

Phantom section: Flat Section; Space 2.5 cm

Test Date: 11-29-2010; Ambient Temp: 23.7 °C; Tissue Temp: 21.9 °C

Probe: EX3DV4 - SN3561; ConvF(3.25, 3.25, 3.25); Calibrated: 8/19/2010

Sensor-Surface: 2mm (Mechanical Surface Detection)

Electronics: DAE4 Sn665; Calibrated: 4/21/2010

Phantom: SAM with CRP; Type: SAM; Serial: TP1375

Measurement SW: DASY4, V4.7 Build 80; Postprocessing SW: SEMCAD, V1.8 Build 186

Mode: WLAN 802.11n 5.8 GHz, Body Front, Ch. 149, 7.2 Mbps

Area Scan (9x16x1): Measurement grid: dx=10mm, dy=10mm

Zoom Scan (7x7x11)/Cube 0: Measurement grid: dx=4mm, dy=4mm, dz=2mm

Reference Value = 0.615 V/m

Peak SAR (extrapolated) = 0.068 W/kg

SAR(1 g) = 0.027 mW/g; SAR(10 g) = 0.017 mW/g

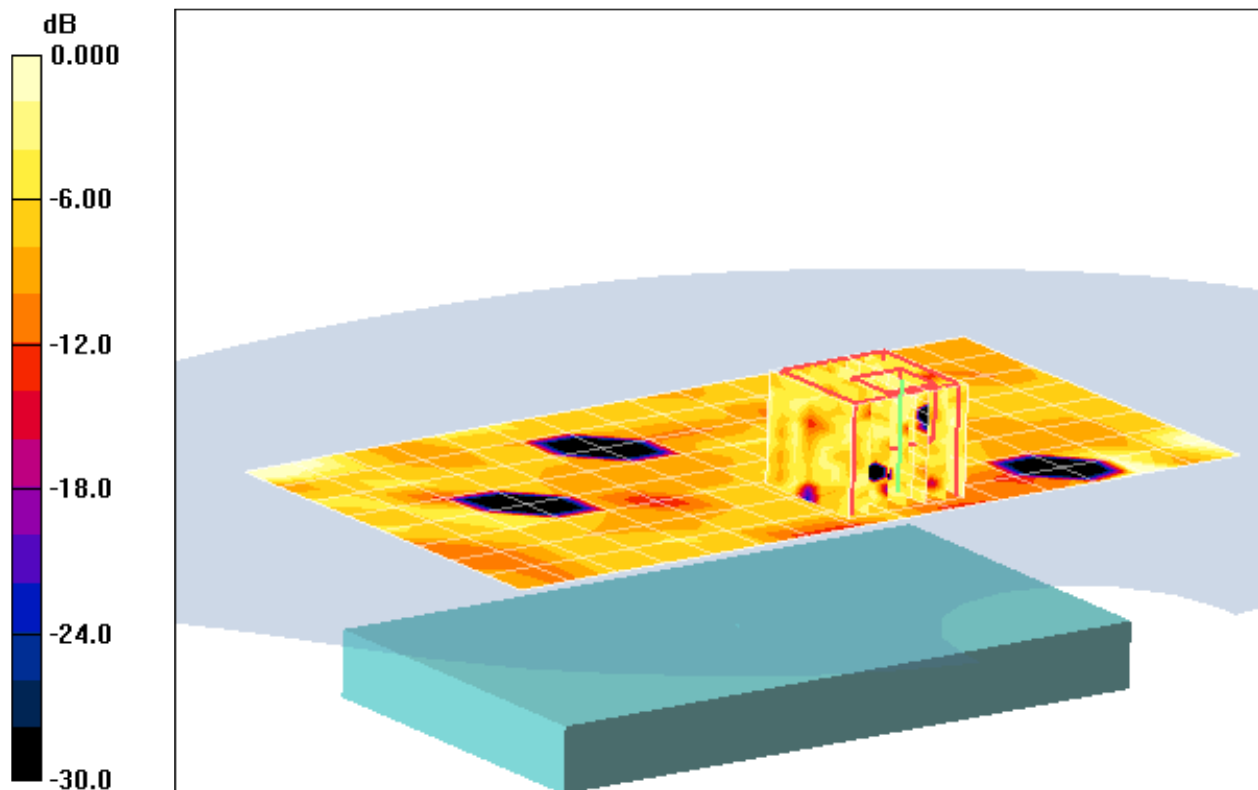

0 dB = 0.060mW/g

PCTEST ENGINEERING LABORATORY, INC.

DUT: MB860; Type: Portable Handset with 5 GHz WLAN; Serial: 353648040030974

Communication System: IEEE 802.11a 5.2-5.8 GHz Band; Frequency: 5745 MHz; Duty Cycle: 1:1

Medium: 5 GHz Medium parameters used (interpolated):

$f = 5745 \text{ MHz}$; $\sigma = 6.01 \text{ mho/m}$; $\epsilon_r = 46.4$; $\rho = 1000 \text{ kg/m}^3$

Phantom section: Flat Section; Space 2.5 cm

Test Date: 11-29-2010; Ambient Temp: 23.7 °C; Tissue Temp: 21.9 °C

Probe: EX3DV4 - SN3561; ConvF(3.25, 3.25, 3.25); Calibrated: 8/19/2010

Sensor-Surface: 2mm (Mechanical Surface Detection)

Electronics: DAE4 Sn665; Calibrated: 4/21/2010

Phantom: SAM with CRP; Type: SAM; Serial: TP1375

Measurement SW: DASY4, V4.7 Build 80; Postprocessing SW: SEMCAD, V1.8 Build 186

Mode: WLAN 802.11a 5.8 GHz, Body Back, Ch. 149, 6Mbps

Area Scan (9x16x1): Measurement grid: dx=10mm, dy=10mm

Zoom Scan (7x7x11)/Cube 0: Measurement grid: dx=4mm, dy=4mm, dz=2mm

Reference Value = 3.05 V/m

Peak SAR (extrapolated) = 0.200 W/kg

SAR(1 g) = 0.049 mW/g; SAR(10 g) = 0.028 mW/g

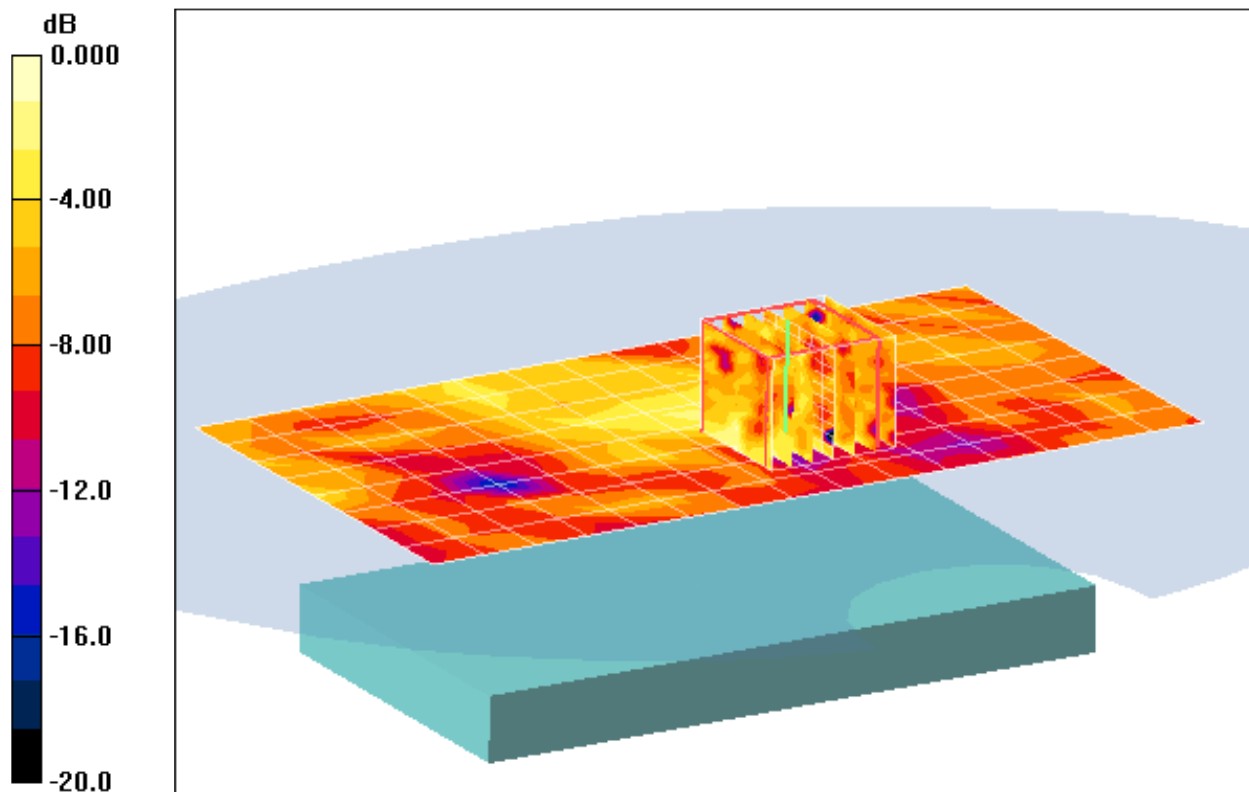

0 dB = 0.080mW/g

PCTEST ENGINEERING LABORATORY, INC.

DUT: MB860; Type: Portable Handset with 5 GHz WLAN; Serial: 353648040030974

Communication System: IEEE 802.11a 5.2-5.8 GHz Band; Frequency: 5745 MHz; Duty Cycle: 1:1

Medium: 5 GHz Medium parameters used (interpolated):

$f = 5745$ MHz; $\sigma = 6.01$ mho/m; $\epsilon_r = 46.4$; $\rho = 1000$ kg/m³

Phantom section: Flat Section; Space 1.0 cm

Test Date: 11-29-2010; Ambient Temp: 23.7 °C; Tissue Temp: 21.9 °C

Probe: EX3DV4 - SN3561; ConvF(3.25, 3.25, 3.25); Calibrated: 8/19/2010

Sensor-Surface: 2mm (Mechanical Surface Detection)

Electronics: DAE4 Sn665; Calibrated: 4/21/2010

Phantom: SAM with CRP; Type: SAM; Serial: TP1375

Measurement SW: DASY4, V4.7 Build 80; Postprocessing SW: SEMCAD, V1.8 Build 186

Mode: WLAN 802.11a 5.8 GHz, Body Back, Ch. 149, 6 Mbps

Area Scan (9x16x1): Measurement grid: dx=10mm, dy=10mm

Zoom Scan (7x7x11)/Cube 0: Measurement grid: dx=4mm, dy=4mm, dz=2mm

Reference Value = 3.77 V/m;

Peak SAR (extrapolated) = 0.570 W/kg

SAR(1 g) = 0.074 mW/g; SAR(10 g) = 0.031 mW/g

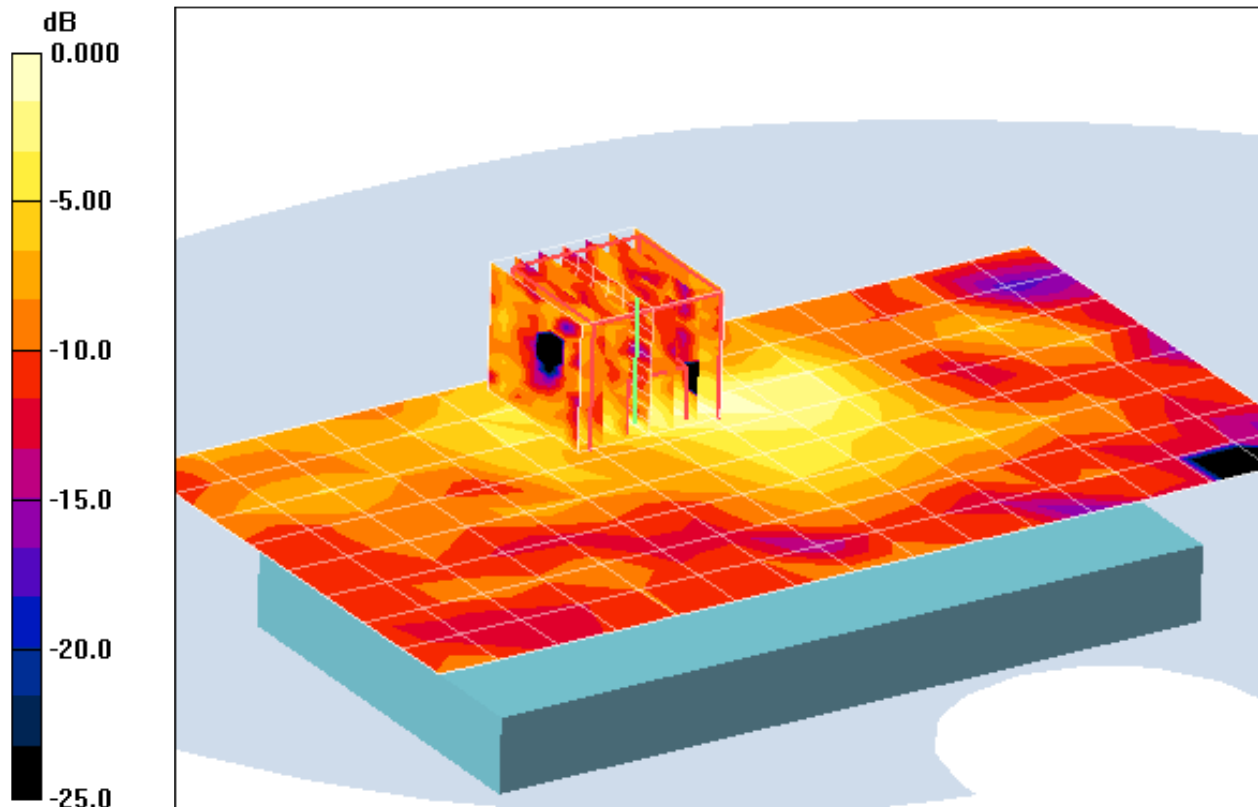

0 dB = 0.173mW/g

PCTEST ENGINEERING LABORATORY, INC.

DUT: MB860; Type: Portable Handset with 5 GHz WLAN; Serial: 353648040030974

Communication System: IEEE 802.11a 5.2-5.8 GHz Band; Frequency: 5745 MHz; Duty Cycle: 1:1

Medium: 5 GHz Medium parameters used (interpolated):

$f = 5745$ MHz; $\sigma = 6.01$ mho/m; $\epsilon_r = 46.4$; $\rho = 1000$ kg/m³

Phantom section: Flat Section; Space: 1.0 cm

Test Date: 11-29-2010; Ambient Temp: 23.7 °C; Tissue Temp: 21.9 °C

Probe: EX3DV4 - SN3561; ConvF(3.25, 3.25, 3.25); Calibrated: 8/19/2010

Sensor-Surface: 2mm (Mechanical Surface Detection)

Electronics: DAE4 Sn665; Calibrated: 4/21/2010

Phantom: SAM with CRP; Type: SAM; Serial: TP1375

Measurement SW: DASY4, V4.7 Build 80; Postprocessing SW: SEMCAD, V1.8 Build 186

Mode: WLAN 802.11a 5.8 GHz, Body Front, Ch. 149, 6 Mbps

Area Scan Use for Plots (9x16x1): Measurement grid: dx=10mm, dy=10mm

Zoom Scan (7x7x11)/Cube 0: Measurement grid: dx=4mm, dy=4mm, dz=2mm

Reference Value = 2.31 V/m

Peak SAR (extrapolated) = 0.206 W/kg

SAR(1 g) = 0.039 mW/g; SAR(10 g) = 0.021 mW/g

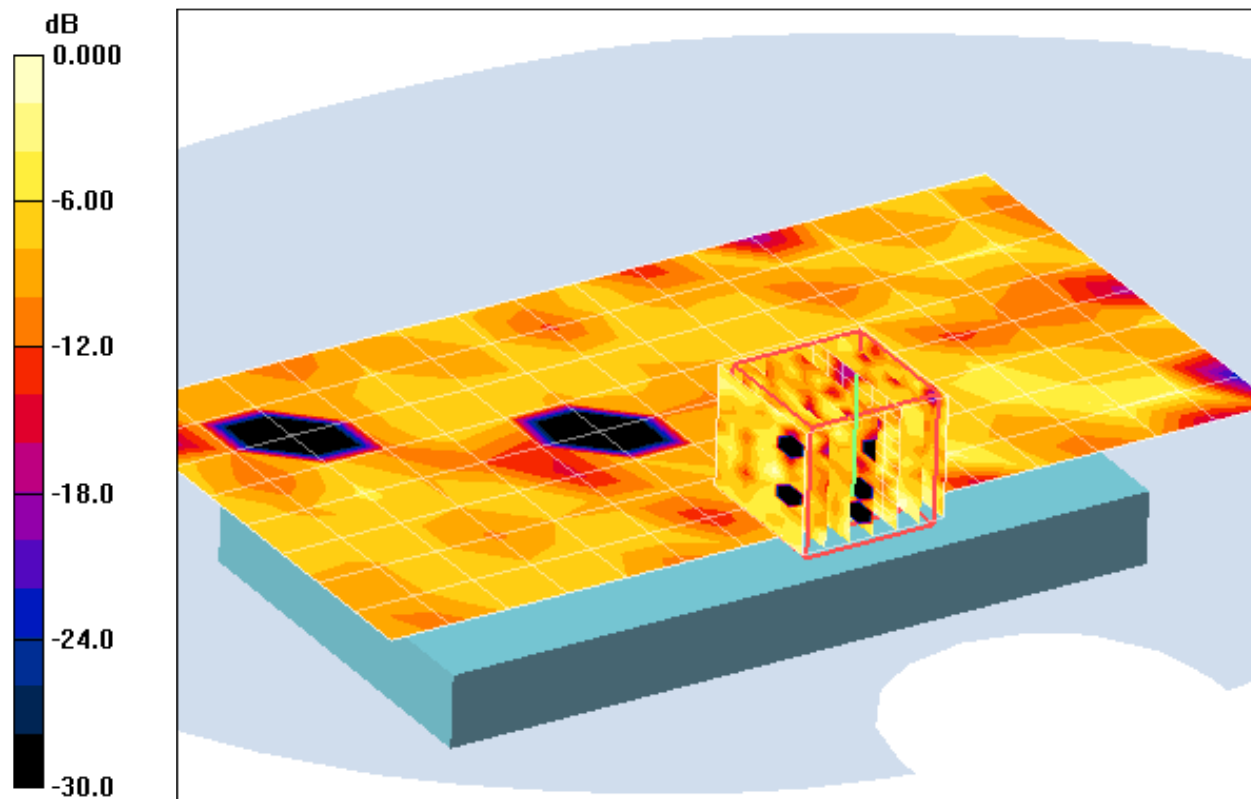

0 dB = 0.060mW/g

PCTEST ENGINEERING LABORATORY, INC.

DUT: MB860; Type: Portable Handset with 5 GHz WLAN; Serial: 353648040030974

Communication System: IEEE 802.11a 5.2-5.8 GHz Band; 5745 MHz; Duty Cycle: 1:1

Medium: 5 GHz Medium parameters used (interpolated):

$f = 5745$ MHz; $\sigma = 6.01$ mho/m; $\epsilon_r = 46.4$; $\rho = 1000$ kg/m³

Phantom section: Flat Section; Space: 1.0 cm

Test Date: 11-29-2010; Ambient Temp: 23.7 °C; Tissue Temp: 21.9 °C

Probe: EX3DV4 - SN3561; ConvF(3.25, 3.25, 3.25); Calibrated: 8/19/2010

Sensor-Surface: 2mm (Mechanical Surface Detection)

Electronics: DAE4 Sn665; Calibrated: 4/21/2010

Phantom: SAM with CRP; Type: SAM; Serial: TP1375

Measurement SW: DASY4, V4.7 Build 80; Postprocessing SW: SEMCAD, V1.8 Build 186

Mode: WLAN 802.11n 5.8 GHz, Body Right, Ch. 149, 7.2 Mbps

Area Scan (5x16x1): Measurement grid: dx=10mm, dy=10mm

Zoom Scan (7x7x11)/Cube 0: Measurement grid: dx=4mm, dy=4mm, dz=2mm

Reference Value = 3.59 V/m

Peak SAR (extrapolated) = 0.366 W/kg

SAR(1 g) = 0.082 mW/g; SAR(10 g) = 0.040 mW/g

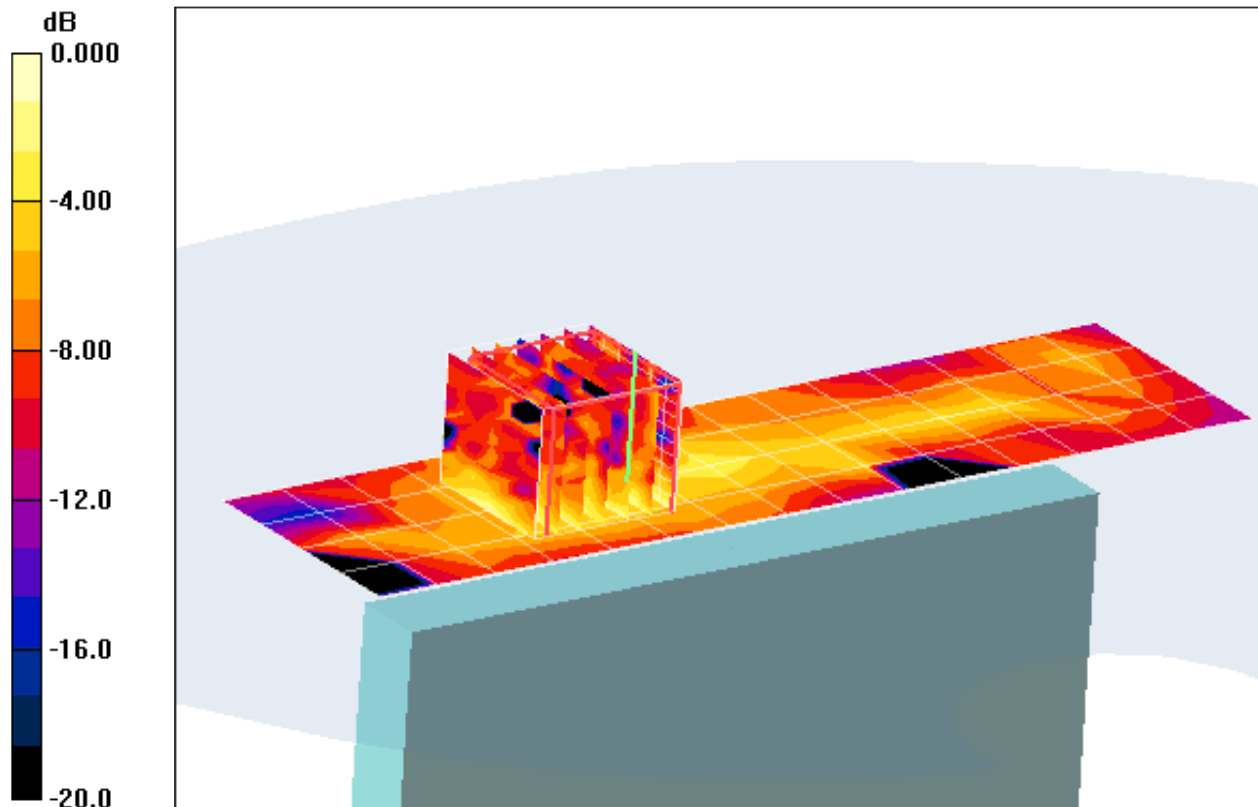

0 dB = 0.153mW/g

APPENDIX B: DIPOLE VALIDATION

PCTEST ENGINEERING LABORATORY, INC.

DUT: Dipole 5200 MHz; Type: D5GHzV2; Serial: 1007

Communication System: CW; Frequency: 5200 MHz; Duty Cycle: 1:1

Medium: 5 GHz Medium parameters used (interpolated):

$f = 5200$ MHz; $\sigma = 5.102$ mho/m; $\epsilon_r = 47.9$; $\rho = 1000$ kg/m³

Phantom section: Flat Section; Space: 1.0 cm

Test Date: 11-29-2010; Ambient Temp: 23.5°C; Tissue Temp: 22.3°C

Probe: EX3DV4 - SN3561; ConvF(3.67, 3.67, 3.67); Calibrated: 8/19/2010

Sensor-Surface: 2mm (Mechanical Surface Detection)

Electronics: DAE4 Sn665; Calibrated: 4/21/2010

Phantom: SAM with CRP; Type: SAM; Serial: TP1375

Measurement SW: DASY4, V4.7 Build 80; Postprocessing SW: SEMCAD, V1.8 Build 186

5200MHz System Verification

Area Scan (7x9x1): Measurement grid: dx=10mm, dy=10mm

Zoom Scan (7x7x11)/Cube 0: Measurement grid: dx=4mm, dy=4mm, dz=2mm

Input Power = 14 dBm (25 mW)

SAR(1 g) = 1.93 mW/g; SAR(10 g) = 0.530 mW/g

Deviation = -2.15 %

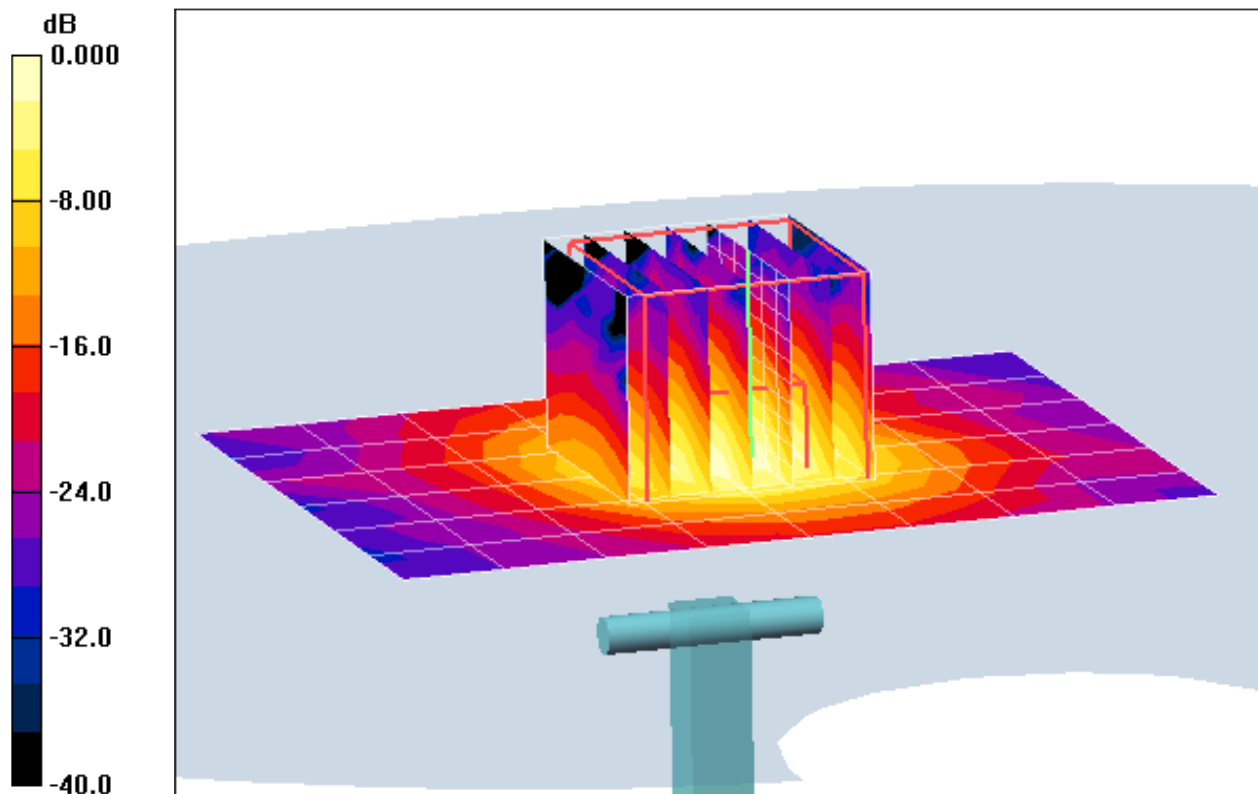

0 dB = 3.86mW/g

PCTEST ENGINEERING LABORATORY, INC.

DUT: Dipole 5800 MHz; Type: D5GHzV2; Serial: 1007

Communication System: CW; Frequency: 5800 MHz; Duty Cycle: 1:1

Medium: 5 GHz Medium parameters used (interpolated):

$f = 5800 \text{ MHz}$; $\sigma = 6.06 \text{ mho/m}$; $\epsilon_r = 46.5$; $\rho = 1000 \text{ kg/m}^3$

Phantom section: Flat Section; Space: 1.0 cm

Test Date: 11-29-2010; Ambient Temp: 23.7 °C; Tissue Temp: 21.9 °C

Probe: EX3DV4 - SN3561; ConvF(3.25, 3.25, 3.25); Calibrated: 8/19/2010

Sensor-Surface: 2mm (Mechanical Surface Detection)

Electronics: DAE4 Sn665; Calibrated: 4/21/2010

Phantom: SAM with CRP; Type: SAM; Serial: TP1375

Measurement SW: DASY4, V4.7 Build 80; Postprocessing SW: SEMCAD, V1.8 Build 186

5800MHz System Verification

Area Scan (7x9x1): Measurement grid: dx=10mm, dy=10mm

Zoom Scan (7x7x11)/Cube 0: Measurement grid: dx=4mm, dy=4mm, dz=2mm

Input Power = 14.0 Bm (25 mW)

SAR(1 g) = 1.95 mW/g; SAR(10 g) = 0.536 mW/g

Deviation = 7.88 %

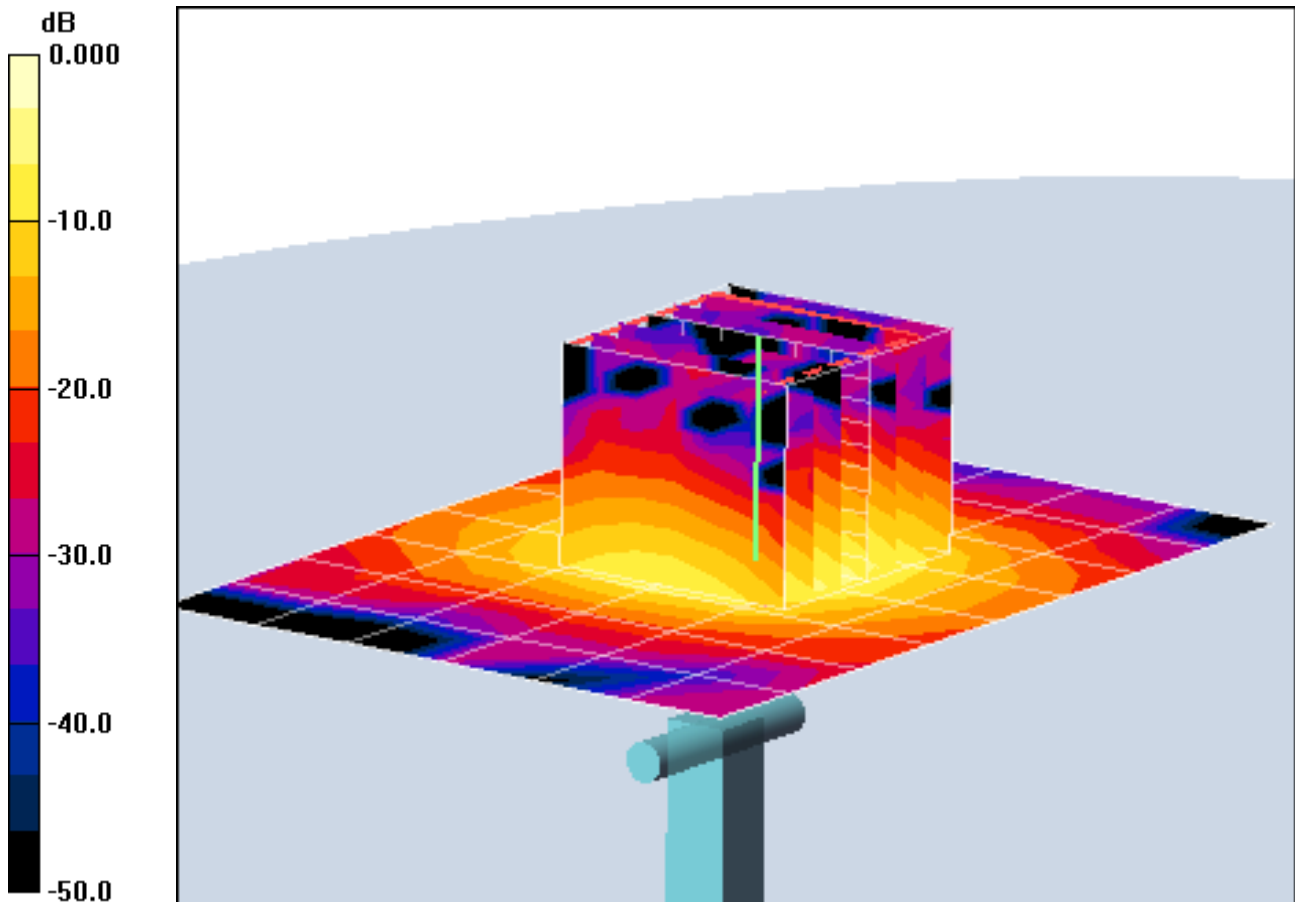

0 dB = 4.18mW/g

APPENDIX C: PROBE CALIBRATION



Accredited by the Swiss Accreditation Service (SAS)
The Swiss Accreditation Service is one of the signatories to the EA
Multilateral Agreement for the recognition of calibration certificates

Accreditation No.: SCS 108

Client **PC Test**

Certificate No: **EX3-3561_Aug10**

CALIBRATION CERTIFICATE

Object **EX3DV4 - SN:3561**

Calibration procedure(s) **QA CAL-01.v6, QA CAL-14.v3, QA CAL-23.v3 and QA CAL-25.v2
Calibration procedure for dosimetric E-field probes**

Calibration date: **August 19, 2010**

*KOK
8/30/10*

This calibration certificate documents the traceability to national standards, which realize the physical units of measurements (SI).
The measurements and the uncertainties with confidence probability are given on the following pages and are part of the certificate.

All calibrations have been conducted in the closed laboratory facility: environment temperature (22 ± 3)°C and humidity < 70%.

Calibration Equipment used (M&TE critical for calibration)

Primary Standards	ID #	Cal Date (Certificate No.)	Scheduled Calibration
Power meter E4419B	GB41293874	1-Apr-10 (No. 217-01136)	Apr-11
Power sensor E4412A	MY41495277	1-Apr-10 (No. 217-01136)	Apr-11
Power sensor E4412A	MY41498087	1-Apr-10 (No. 217-01136)	Apr-11
Reference 3 dB Attenuator	SN: S5054 (3c)	30-Mar-10 (No. 217-01159)	Mar-11
Reference 20 dB Attenuator	SN: S5086 (20b)	30-Mar-10 (No. 217-01161)	Mar-11
Reference 30 dB Attenuator	SN: S5129 (30b)	30-Mar-10 (No. 217-01160)	Mar-11
Reference Probe ES3DV2	SN: 3013	30-Dec-09 (No. ES3-3013_Dec09)	Dec-10
DAE4	SN: 660	20-Apr-10 (No. DAE4-660_Apr10)	Apr-11
Secondary Standards	ID #	Check Date (in house)	Scheduled Check
RF generator HP 8648C	US3642U01700	4-Aug-99 (in house check Oct-09)	In house check: Oct-11
Network Analyzer HP 8753E	US37390585	18-Oct-01 (in house check Oct-09)	In house check: Oct10

Calibrated by:	Name Katja Pokovic	Function Technical Manager	Signature
Approved by:	Name Niels Kuster	Function Quality Manager	

Issued: August 20, 2010

This calibration certificate shall not be reproduced except in full without written approval of the laboratory.



Accredited by the Swiss Accreditation Service (SAS)
The Swiss Accreditation Service is one of the signatories to the EA
Multilateral Agreement for the recognition of calibration certificates

Accreditation No.: **SCS 108**

Glossary:

TSL	tissue simulating liquid
NORM _{x,y,z}	sensitivity in free space
ConvF	sensitivity in TSL / NORM _{x,y,z}
DCP	diode compression point
CF	crest factor (1/duty_cycle) of the RF signal
A, B, C	modulation dependent linearization parameters
Polarization φ	φ rotation around probe axis
Polarization ϑ	ϑ rotation around an axis that is in the plane normal to probe axis (at measurement center), i.e., $\vartheta = 0$ is normal to probe axis

Calibration is Performed According to the Following Standards:

- IEEE Std 1528-2003, "IEEE Recommended Practice for Determining the Peak Spatial-Averaged Specific Absorption Rate (SAR) in the Human Head from Wireless Communications Devices: Measurement Techniques", December 2003
- IEC 62209-1, "Procedure to measure the Specific Absorption Rate (SAR) for hand-held devices used in close proximity to the ear (frequency range of 300 MHz to 3 GHz)", February 2005

Methods Applied and Interpretation of Parameters:

- NORM_{x,y,z}**: Assessed for E-field polarization $\vartheta = 0$ ($f \leq 900$ MHz in TEM-cell; $f > 1800$ MHz: R22 waveguide). NORM_{x,y,z} are only intermediate values, i.e., the uncertainties of NORM_{x,y,z} does not effect the E²-field uncertainty inside TSL (see below ConvF).
- NORM(f)_{x,y,z}** = NORM_{x,y,z} * frequency_response (see Frequency Response Chart). This linearization is implemented in DASY4 software versions later than 4.2. The uncertainty of the frequency response is included in the stated uncertainty of ConvF.
- DCP_{x,y,z}**: DCP are numerical linearization parameters assessed based on the data of power sweep with CW signal (no uncertainty required). DCP does not depend on frequency nor media.
- A_{x,y,z}; B_{x,y,z}; C_{x,y,z}; VR_{x,y,z}**: A, B, C are numerical linearization parameters assessed based on the data of power sweep for specific modulation signal. The parameters do not depend on frequency nor media. VR is the maximum calibration range expressed in RMS voltage across the diode.
- ConvF and Boundary Effect Parameters**: Assessed in flat phantom using E-field (or Temperature Transfer Standard for $f \leq 800$ MHz) and inside waveguide using analytical field distributions based on power measurements for $f > 800$ MHz. The same setups are used for assessment of the parameters applied for boundary compensation (alpha, depth) of which typical uncertainty values are given. These parameters are used in DASY4 software to improve probe accuracy close to the boundary. The sensitivity in TSL corresponds to NORM_{x,y,z} * ConvF whereby the uncertainty corresponds to that given for ConvF. A frequency dependent ConvF is used in DASY version 4.4 and higher which allows extending the validity from ± 50 MHz to ± 100 MHz.
- Spherical isotropy (3D deviation from isotropy)**: in a field of low gradients realized using a flat phantom exposed by a patch antenna.
- Sensor Offset**: The sensor offset corresponds to the offset of virtual measurement center from the probe tip (on probe axis). No tolerance required.

Probe EX3DV4

SN:3561

Manufactured:	February 14, 2005
Last calibrated:	August 26, 2008
Recalibrated:	August 19, 2010

Calibrated for DASY/EASY Systems

(Note: non-compatible with DASY2 system!)

DASY/EASY - Parameters of Probe: EX3DV4 SN:3561**Basic Calibration Parameters**

	Sensor X	Sensor Y	Sensor Z	Unc (k=2)
Norm ($\mu\text{V}/(\text{V}/\text{m})^2$) ^A	0.45	0.48	0.43	$\pm 10.1\%$
DCP (mV) ^B	87.4	89.6	88.5	

Modulation Calibration Parameters

UID	Communication System Name	PAR		A dB	B dBuV	C	VR mV	Unc ^E (k=2)
10000	CW	0.00	X	0.00	0.00	1.00	300	$\pm 1.5\%$
			Y	0.00	0.00	1.00	300	
			Z	0.00	0.00	1.00	300	

The reported uncertainty of measurement is stated as the standard uncertainty of measurement multiplied by the coverage factor $k=2$, which for a normal distribution corresponds to a coverage probability of approximately 95%.

^A The uncertainties of NormX,Y,Z do not affect the \hat{E} field uncertainty inside TSL (see Pages 5 and 6).

^B Numerical linearization parameter: uncertainty not required.

^E Uncertainty is determined using the maximum deviation from linear response applying rectangular distribution and is expressed for the square of the field value

DASY/EASY - Parameters of Probe: EX3DV4 SN:3561

Calibration Parameter Determined in Head Tissue Simulating Media

f [MHz]	Validity [MHz] ^f	Permittivity	Conductivity	ConvF X	ConvF Y	ConvF Z	Alpha	Depth Unc (k=2)
750	± 50 / ± 100	41.9 ± 5%	0.89 ± 5%	8.36	8.36	8.36	0.76	0.64 ± 11.0%
835	± 50 / ± 100	41.5 ± 5%	0.90 ± 5%	7.96	7.96	7.96	0.75	0.64 ± 11.0%
1750	± 50 / ± 100	40.1 ± 5%	1.37 ± 5%	6.92	6.92	6.92	0.90	0.57 ± 11.0%
1900	± 50 / ± 100	40.0 ± 5%	1.40 ± 5%	6.69	6.69	6.69	0.76	0.63 ± 11.0%
2450	± 50 / ± 100	39.2 ± 5%	1.80 ± 5%	6.11	6.11	6.11	0.42	0.83 ± 11.0%
2600	± 50 / ± 100	39.0 ± 5%	1.96 ± 5%	6.09	6.09	6.09	0.36	0.93 ± 11.0%

^c The validity of ± 100 MHz only applies for DASY v4.4 and higher (see Page 2). The uncertainty is the RSS of the ConvF uncertainty at calibration frequency and the uncertainty for the indicated frequency band.

DASY/EASY - Parameters of Probe: EX3DV4 SN:3561

Calibration Parameter Determined in Body Tissue Simulating Media

f [MHz]	Validity [MHz] ^c	Permittivity	Conductivity	ConvF X	ConvF Y	ConvF Z	Alpha	Depth Unc (k=2)
835	± 50 / ± 100	55.2 ± 5%	0.97 ± 5%	8.09	8.09	8.09	0.74	0.65 ± 11.0%
1750	± 50 / ± 100	53.4 ± 5%	1.49 ± 5%	6.84	6.84	6.84	0.43	0.82 ± 11.0%
1900	± 50 / ± 100	53.3 ± 5%	1.52 ± 5%	6.59	6.59	6.59	0.56	0.71 ± 11.0%
2450	± 50 / ± 100	52.7 ± 5%	1.95 ± 5%	6.44	6.44	6.44	0.37	0.87 ± 11.0%
2600	± 50 / ± 100	52.5 ± 5%	2.16 ± 5%	6.45	6.45	6.45	0.37	0.95 ± 11.0%
4950	± 50 / ± 100	49.4 ± 5%	5.01 ± 5%	3.80	3.80	3.80	0.53	1.90 ± 13.1%
5200	± 50 / ± 100	49.0 ± 5%	5.30 ± 5%	3.67	3.67	3.67	0.60	1.95 ± 13.1%
5300	± 50 / ± 100	48.5 ± 5%	5.42 ± 5%	3.42	3.42	3.42	0.63	1.95 ± 13.1%
5500	± 50 / ± 100	48.6 ± 5%	5.65 ± 5%	3.31	3.31	3.31	0.63	1.95 ± 13.1%
5600	± 50 / ± 100	48.5 ± 5%	5.77 ± 5%	3.12	3.12	3.12	0.65	1.95 ± 13.1%
5800	± 50 / ± 100	48.2 ± 5%	6.00 ± 5%	3.25	3.25	3.25	0.65	1.95 ± 13.1%

^c The validity of ± 100 MHz only applies for DASY v4.4 and higher (see Page 2). The uncertainty is the RSS of the ConvF uncertainty at calibration frequency and the uncertainty for the indicated frequency band.

Frequency Response of E-Field

(TEM-Cell:ifi110 EXX, Waveguide: R22)

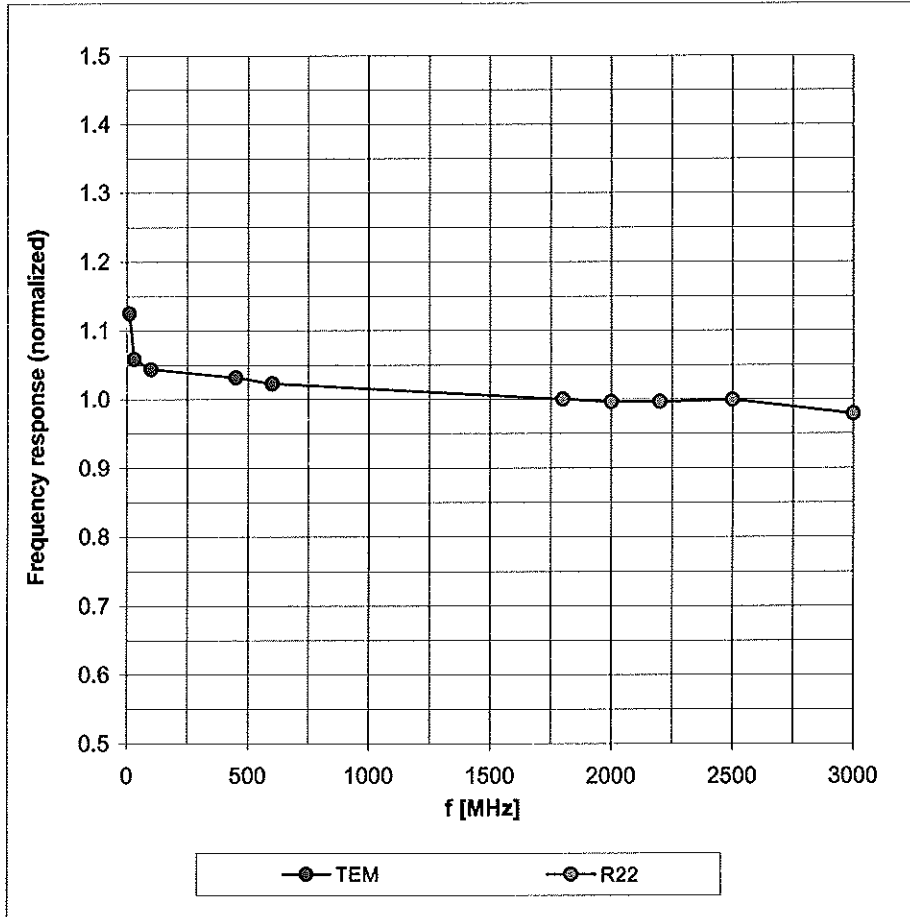

Uncertainty of Frequency Response of E-field: $\pm 6.3\%$ (k=2)

Receiving Pattern (ϕ), $\vartheta = 0^\circ$

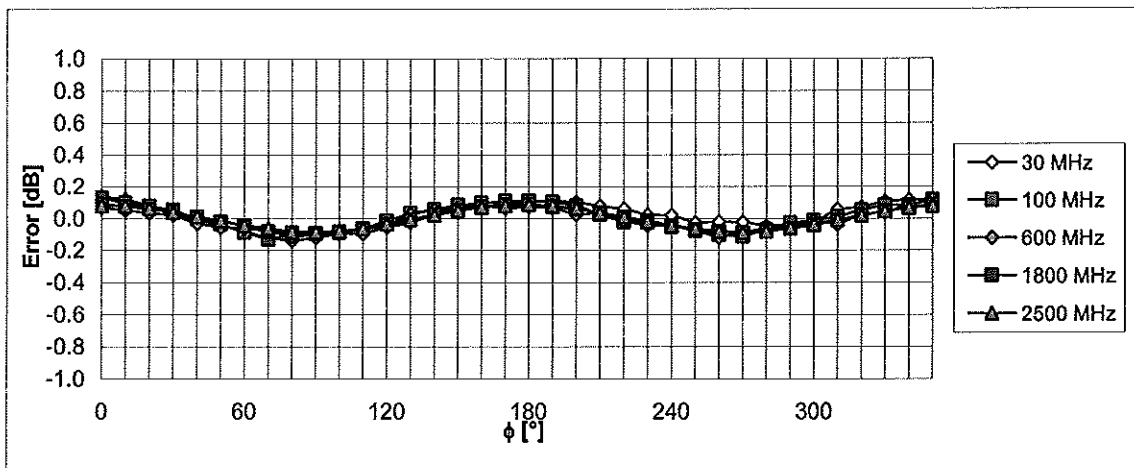
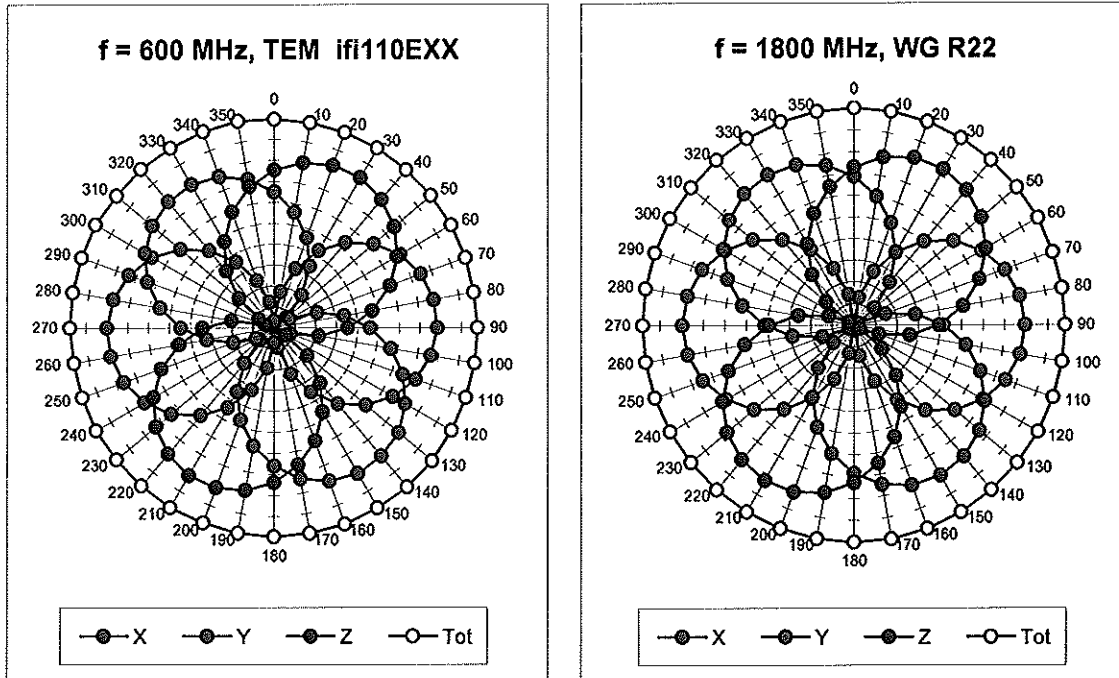

Uncertainty of Axial Isotropy Assessment: $\pm 0.5\%$ (k=2)

Dynamic Range $f(SAR_{head})$ (Waveguide R22, $f = 1800$ MHz)

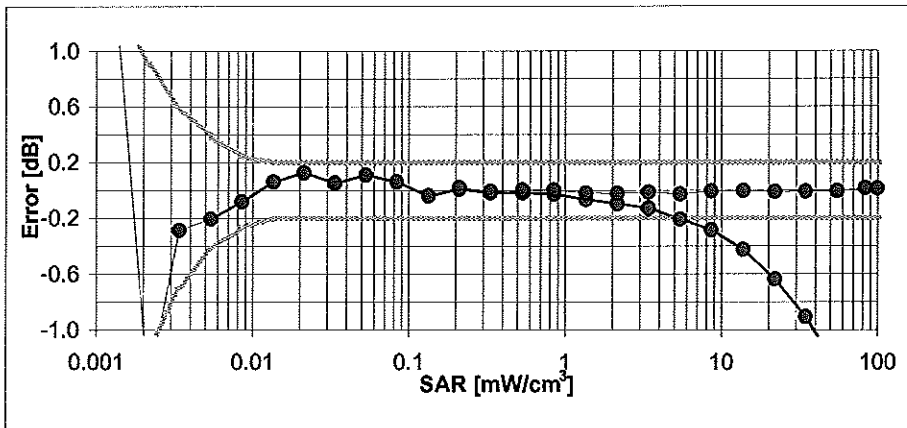
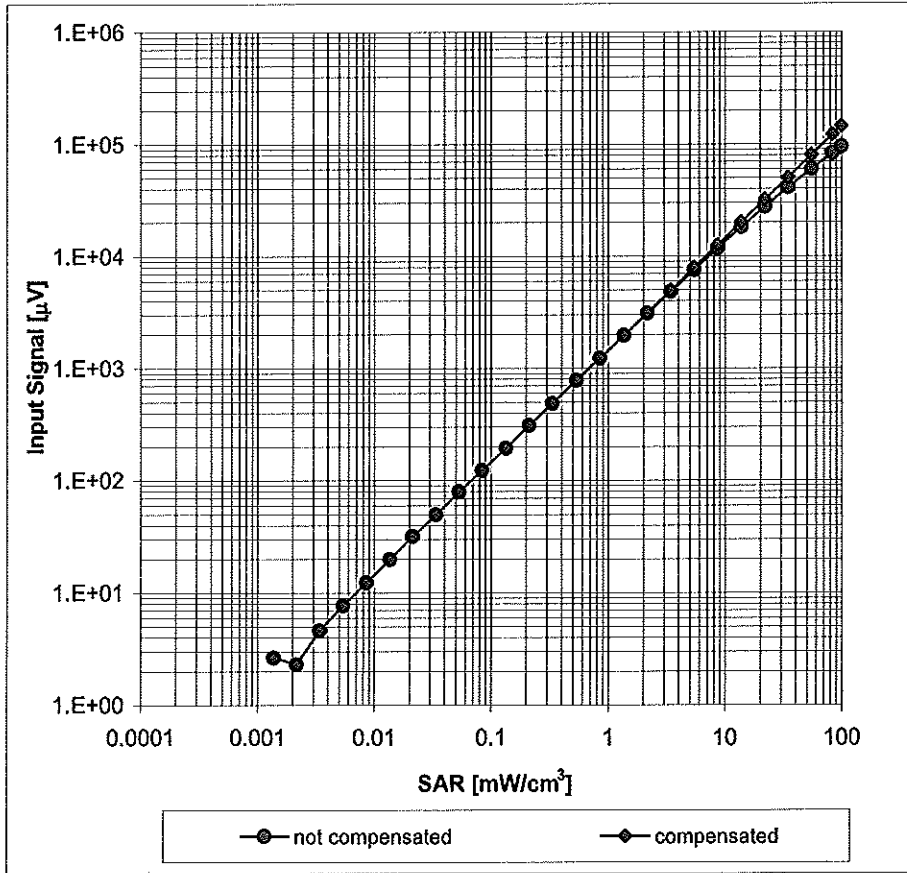

Uncertainty of Linearity Assessment: $\pm 0.6\%$ ($k=2$)

Conversion Factor Assessment

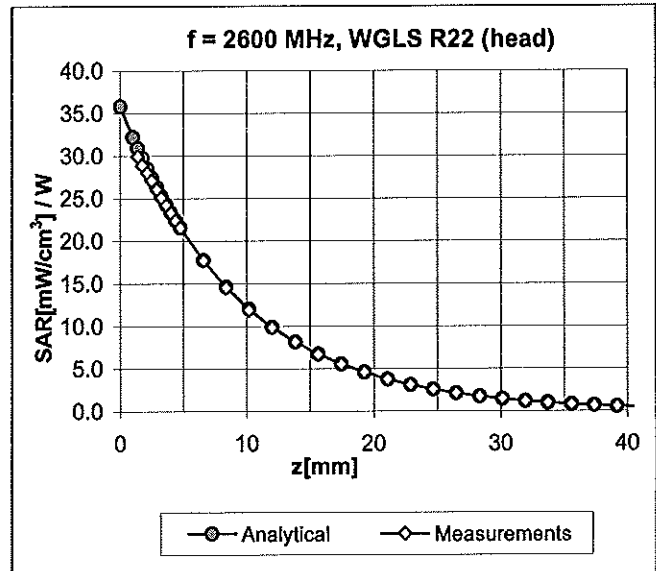
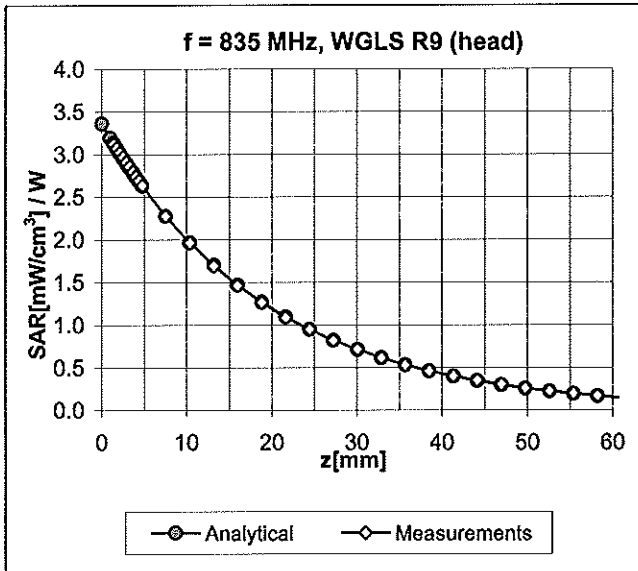

Deviation from Isotropy in HSL

Error (ϕ, θ), f = 900 MHz

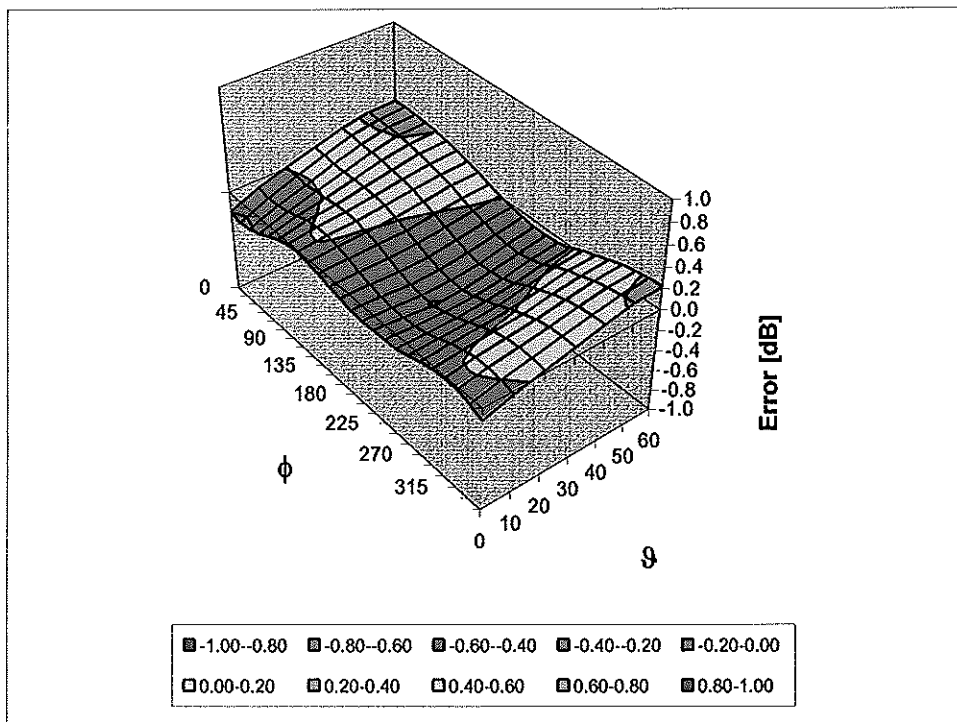

Uncertainty of Spherical Isotropy Assessment: $\pm 2.6\%$ (k=2)

Other Probe Parameters

Sensor Arrangement	Triangular
Connector Angle (°)	Not applicable
Mechanical Surface Detection Mode	enabled
Optical Surface Detection Mode	disabled
Probe Overall Length	337 mm
Probe Body Diameter	10 mm
Tip Length	9 mm
Tip Diameter	2.5 mm
Probe Tip to Sensor X Calibration Point	1 mm
Probe Tip to Sensor Y Calibration Point	1 mm
Probe Tip to Sensor Z Calibration Point	1 mm
Recommended Measurement Distance from Surface	2 mm



Accredited by the Swiss Accreditation Service (SAS)
The Swiss Accreditation Service is one of the signatories to the EA
Multilateral Agreement for the recognition of calibration certificates

Accreditation No.: **SCS 108**

Client **PC Test**

Certificate No: **D5GHzV2-1007_Aug09**

CALIBRATION CERTIFICATE

Object **D5GHzV2 - SN: 1007**

Calibration procedure(s) **QA CAL-22.v1
Calibration procedure for dipole validation kits between 3-6 GHz**

Calibration date: **August 19, 2009**

Condition of the calibrated item **In Tolerance**

This calibration certificate documents the traceability to national standards, which realize the physical units of measurements (SI).
The measurements and the uncertainties with confidence probability are given on the following pages and are part of the certificate.

All calibrations have been conducted in the closed laboratory facility: environment temperature (22 ± 3)°C and humidity < 70%.

OK
8/31/09

Calibration Equipment used (M&TE critical for calibration)

Primary Standards	ID #	Cal Date (Certificate No.)	Scheduled Calibration
Power meter EPM-442A	GB37480704	08-Oct-08 (No. 217-00898)	Oct-09
Power sensor HP 8481A	US37292783	08-Oct-08 (No. 217-00898)	Oct-09
Reference 20 dB Attenuator	SN: 5086 (20g)	31-Mar-09 (No. 217-01025)	Mar-10
Type-N mismatch combination	SN: 5047.2 / 06327	31-Mar-09 (No. 217-01029)	Mar-10
Reference Probe EX3DV4	SN: 3503	11-Mar-09 (No. EX3-3503_Mar09)	Mar-10
DAE4	SN: 601	07-Mar-09 (No. DAE4-601_Mar09)	Mar-10
Secondary Standards	ID #	Check Date (in house)	Scheduled Check
Power sensor HP 8481A	MY41092317	18-Oct-02 (in house check Oct-07)	In house check: Oct-09
RF generator R&S SMT-06	100005	4-Aug-99 (in house check Oct-07)	In house check: Oct-09
Network Analyzer HP 8753E	US37390585 S4206	18-Oct-01 (in house check Oct-08)	In house check: Oct-09

Calibrated by: **Jeton Kastrati** (Name), **Laboratory Technician** (Function), *[Signature]* (Signature)

Approved by: **Kalja Pokovic** (Name), **Technical Manager** (Function), *[Signature]* (Signature)

Issued: August 26, 2009

This calibration certificate shall not be reproduced except in full without written approval of the laboratory.



Accredited by the Swiss Accreditation Service (SAS)
The Swiss Accreditation Service is one of the signatories to the EA
Multilateral Agreement for the recognition of calibration certificates

Accreditation No.: **SCS 108**

Glossary:

TSL	tissue simulating liquid
ConvF	sensitivity in TSL / NORM x,y,z
N/A	not applicable or not measured

Calibration is Performed According to the Following Standards:

- a) IEC Std 62209 Part 2, "Evaluation of Human Exposure to Radio Frequency Fields from Handheld and Body-Mounted Wireless Communication Devices in the Frequency Range of 30 MHz to 6 GHz: Human models, Instrumentation, and Procedures"; Part 2: "Procedure to determine the Specific Absorption Rate (SAR) for including accessories and multiple transmitters", Draft Version 0.9, December 2004
- b) Federal Communications Commission Office of Engineering & Technology (FCC OET), "Evaluating Compliance with FCC Guidelines for Human Exposure to Radiofrequency Electromagnetic Fields; Additional Information for Evaluating Compliance of Mobile and Portable Devices with FCC Limits for Human Exposure to Radiofrequency Emissions", Supplement C (Edition 01-01) to Bulletin 65

Additional Documentation:

- c) DASY4/5 System Handbook

Methods Applied and Interpretation of Parameters:

- *Measurement Conditions:* Further details are available from the Validation Report at the end of the certificate. All figures stated in the certificate are valid at the frequency indicated.
- *Antenna Parameters with TSL:* The dipole is mounted with the spacer to position its feed point exactly below the center marking of the flat phantom section, with the arms oriented parallel to the body axis.
- *Feed Point Impedance and Return Loss:* These parameters are measured with the dipole positioned under the liquid filled phantom. The impedance stated is transformed from the measurement at the SMA connector to the feed point. The Return Loss ensures low reflected power. No uncertainty required.
- *Electrical Delay:* One-way delay between the SMA connector and the antenna feed point. No uncertainty required.
- *SAR measured:* SAR measured at the stated antenna input power.
- *SAR normalized:* SAR as measured, normalized to an input power of 1 W at the antenna connector.
- *SAR for nominal TSL parameters:* The measured TSL parameters are used to calculate the nominal SAR result.

Measurement Conditions

DASY system configuration, as far as not given on page 1.

DASY Version	DASY5	V5.0
Extrapolation	Advanced Extrapolation	
Phantom	Modular Flat Phantom V5.0	
Distance Dipole Center - TSL	10 mm	with Spacer
Area Scan resolution	dx, dy = 10 mm	
Zoom Scan Resolution	dx, dy = 4.0 mm, dz = 2.5 mm	
Frequency	5200 MHz \pm 1 MHz 5500 MHz \pm 1 MHz 5800 MHz \pm 1 MHz	

Body TSL parameters at 5200 MHz

The following parameters and calculations were applied.

	Temperature	Permittivity	Conductivity
Nominal Body TSL parameters	22.0 °C	49.0	5.30 mho/m
Measured Body TSL parameters	(22.0 \pm 0.2) °C	48.2 \pm 6 %	5.46 mho/m \pm 6 %
Body TSL temperature during test	(22.5 \pm 0.2) °C	----	----

SAR result with Body TSL at 5200 MHz

SAR averaged over 1 cm ³ (1 g) of Body TSL	condition	
SAR measured	100 mW input power	7.92 mW / g
SAR normalized	normalized to 1W	79.2 mW / g
SAR for nominal Body TSL parameters ¹	normalized to 1W	78.9 mW / g \pm 19.9 % (k=2)

SAR averaged over 10 cm ³ (10 g) of Body TSL	condition	
SAR measured	100 mW input power	2.21 mW / g
SAR normalized	normalized to 1W	22.1 mW / g
SAR for nominal Body TSL parameters ¹	normalized to 1W	22.0 mW / g \pm 19.5 % (k=2)

Body TSL parameters at 5500 MHz

The following parameters and calculations were applied.

	Temperature	Permittivity	Conductivity
Nominal Body TSL parameters	22.0 °C	48.6	5.65 mho/m
Measured Body TSL parameters	(22.0 ± 0.2) °C	47.4 ± 6 %	5.85 mho/m ± 6 %
Body TSL temperature during test	(22.5 ± 0.2) °C	----	----

SAR result with Body TSL at 5500 MHz

SAR averaged over 1 cm ³ (1 g) of Body TSL	condition	
SAR measured	100 mW input power	8.45 mW / g
SAR normalized	normalized to 1W	84.5 mW / g
SAR for nominal Body TSL parameters ¹	normalized to 1W	84.1 mW / g ± 19.9 % (k=2)

SAR averaged over 10 cm ³ (10 g) of Body TSL	condition	
SAR measured	100 mW input power	2.34 mW / g
SAR normalized	normalized to 1W	23.4 mW / g
SAR for nominal Body TSL parameters ¹	normalized to 1W	23.3 mW / g ± 19.5 % (k=2)

Body TSL parameters at 5800 MHz

The following parameters and calculations were applied.

	Temperature	Permittivity	Conductivity
Nominal Body TSL parameters	22.0 °C	48.2	6.00 mho/m
Measured Body TSL parameters	(22.0 ± 0.2) °C	46.9 ± 6 %	6.21 mho/m ± 6 %
Body TSL temperature during test	(22.5 ± 0.2) °C	----	----

SAR result with Body TSL at 5800 MHz

SAR averaged over 1 cm ³ (1 g) of Body TSL	condition	
SAR measured	100 mW input power	7.26 mW / g
SAR normalized	normalized to 1W	72.6 mW / g
SAR for nominal Body TSL parameters ¹	normalized to 1W	72.3 mW / g ± 19.9 % (k=2)

SAR averaged over 10 cm ³ (10 g) of Body TSL	condition	
SAR measured	100 mW input power	2.00 mW / g
SAR normalized	normalized to 1W	20.0 mW / g
SAR for nominal Body TSL parameters ¹	normalized to 1W	19.9 mW / g ± 19.5 % (k=2)

¹ Correction to nominal TSL parameters according to c), chapter "SAR Sensitivities"

Appendix

Antenna Parameters with Body TSL at 5200 MHz

Impedance, transformed to feed point	53.7 Ω - 10.5 j Ω
Return Loss	-19.5 dB

Antenna Parameters with Body TSL at 5500 MHz

Impedance, transformed to feed point	49.7 Ω - 1.7 j Ω
Return Loss	-35.2 dB

Antenna Parameters with Body TSL at 5800 MHz

Impedance, transformed to feed point	58.4 Ω + 6.0 j Ω
Return Loss	-20.5 dB

General Antenna Parameters and Design

Electrical Delay (one direction)	1.200 ns
----------------------------------	----------

After long term use with 40 W radiated power, only a slight warming of the dipole near the feedpoint can be measured.

The dipole is made of standard semirigid coaxial cable. The center conductor of the feeding line is directly connected to the second arm of the dipole. The antenna is therefore short-circuited for DC-signals.

No excessive force must be applied to the dipole arms, because they might bend or the soldered connections near the feedpoint may be damaged.

Additional EUT Data

Manufactured by	SPEAG
Manufactured on	August 28, 2003

DASY5 Validation Report for Body TSL

Date/Time: 19.08.2009 11:42:20

Test Laboratory: SPEAG, Zurich, Switzerland

DUT: Dipole 5GHz; Type: D5GHz; Serial: D5GHzV2 - SN:1007

Communication System: CW-5GHz; Frequency: 5200 MHz; Frequency: 5500 MHz; Frequency: 5800 MHz;
Duty Cycle: 1:1

Medium: MSL 3-6 GHz

Medium parameters used: $f = 5200$ MHz; $\sigma = 5.43$ mho/m; $\epsilon_r = 48.2$; $\rho = 1000$ kg/m³ Medium parameters used: $f = 5500$ MHz; $\sigma = 5.82$ mho/m; $\epsilon_r = 47.5$; $\rho = 1000$ kg/m³ Medium parameters used: $f = 5800$ MHz; $\sigma = 6.17$ mho/m; $\epsilon_r = 46.9$; $\rho = 1000$ kg/m³

Phantom section: Flat Section

Measurement Standard: DASY5 (IEEE/IEC)

DASY5 Configuration:

- Probe: EX3DV4 - SN3503; ConvF(4.88, 4.88, 4.88)ConvF(4.37, 4.37, 4.37)ConvF(4.57, 4.57, 4.57); Calibrated: 11.03.2009
- Sensor-Surface: 2mm (Mechanical Surface Detection)
- Electronics: DAE4 Sn601; Calibrated: 07.03.2009
- Phantom: Flat Phantom 5.0 (back); Type: QD000P50AA; Serial: 1002
- Measurement SW: DASY5, V5.0 Build 120; SEMCAD X Version 13.4 Build 45

d=10mm, Pin=100mW, f=5200 MHz/Area Scan (61x61x1): Measurement grid: dx=10mm, dy=10mm

Maximum value of SAR (interpolated) = 16.6 mW/g

d=10mm, Pin=100mW, f=5200 MHz/Zoom Scan (8x8x10), dist=2mm (8x8x10)/Cube 0:

Measurement grid: dx=4mm, dy=4mm, dz=2.5mm

Reference Value = 60 V/m; Power Drift = -0.00623 dB

Peak SAR (extrapolated) = 30.1 W/kg

SAR(1 g) = 7.92 mW/g; SAR(10 g) = 2.21 mW/g

Maximum value of SAR (measured) = 16.6 mW/g

d=10mm, Pin=100mW, f=5500 MHz/Zoom Scan (8x8x10), dist=2mm (8x8x10)/Cube 0:

Measurement grid: dx=4mm, dy=4mm, dz=2.5mm

Reference Value = 60.3 V/m; Power Drift = -0.042 dB

Peak SAR (extrapolated) = 34.2 W/kg

SAR(1 g) = 8.45 mW/g; SAR(10 g) = 2.34 mW/g

Maximum value of SAR (measured) = 18.2 mW/g

d=10mm, Pin=100mW, f=5800 MHz/Zoom Scan (8x8x10), dist=2mm (8x8x10)/Cube 0:

Measurement grid: dx=4mm, dy=4mm, dz=2.5mm

Reference Value = 54.5 V/m; Power Drift = -0.016 dB

Peak SAR (extrapolated) = 31.3 W/kg

SAR(1 g) = 7.26 mW/g; SAR(10 g) = 2 mW/g

Maximum value of SAR (measured) = 15.9 mW/g

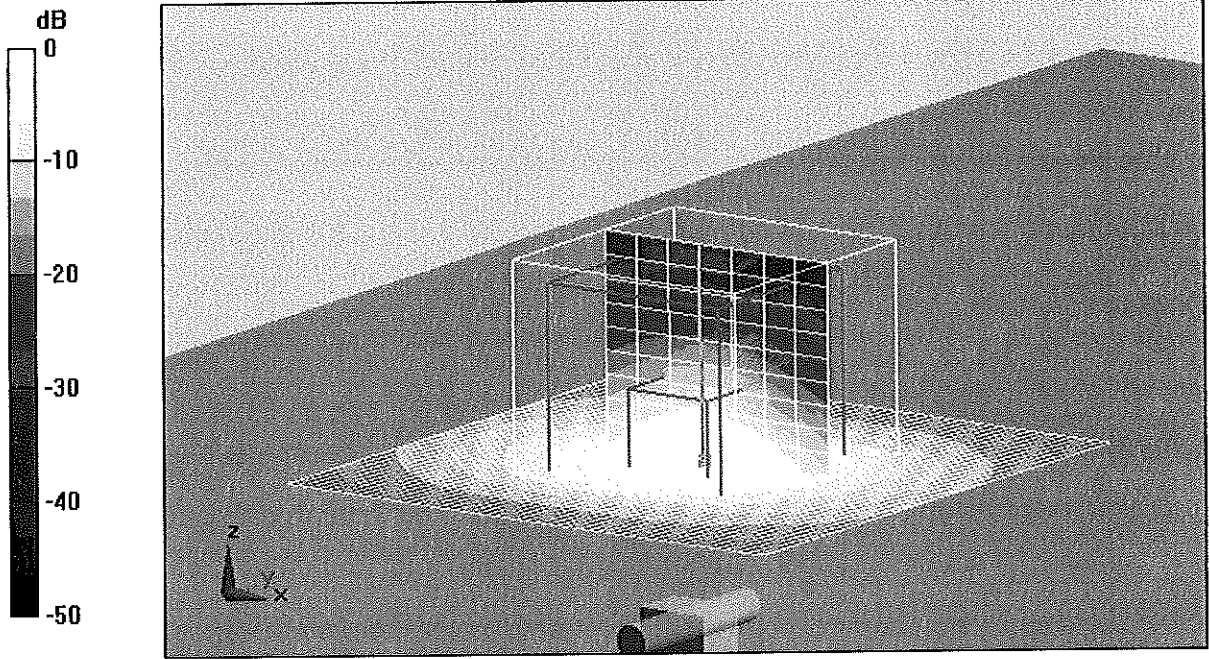

0 dB = 15.9mW/g

Impedance Measurement Plot for Body TSL

19 Aug 2009 08:02:08

CH1 S11 1 U FS 1: 53.744 Ω -10.455 Ω 2.9275 pF 5 200.000 000 MHz

*
De1
Cor
Avg
16
↑

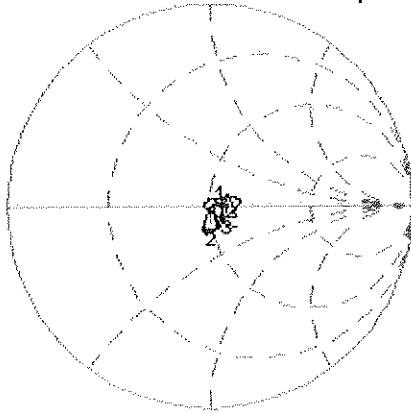

CH1 Markers

2: 49.705 Ω
-1.7051 Ω
5.50000 GHz
3: 58.367 Ω
5.3902 Ω
5.80000 GHz

CH2 S11 LOG 5 dB/REF -20 dB 1: -19.452 dB 5 200.000 000 MHz

Cor
Avg
16
↑

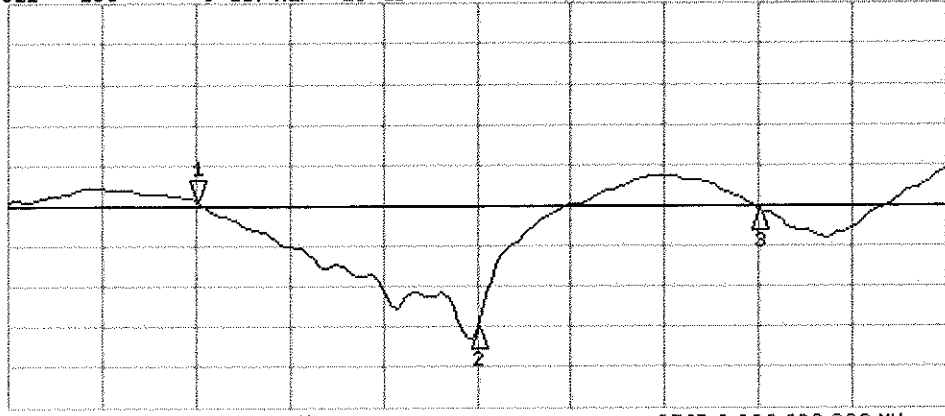

CH2 Markers

2: -35.210 dB
5.50000 GHz
3: -20.461 dB
5.80000 GHz

START 5 000.000 000 MHz

STOP 5 000.000 000 MHz