



**MOTOROLA**



TESTING CERT # 2518.01

FCC ID: IHDP56KY1

**DECLARATION OF COMPLIANCE SAR ASSESSMENT Part 1 of 2**

**Enterprise Mobility Solutions**  
**EME Test Laboratory**  
 8000 West Sunrise Blvd  
 Fort Lauderdale, FL. 33322.

**Date of Report:** 01/13/2010  
**Report Revision:** 0  
**Report ID:** SAR rpt\_H88XAH6JR2AN\_Rev  
 O\_01132010\_SR7814

**Responsible Engineer:** Stephen C. Whalen (Principal Staff Eng.)  
**Report Author:** Stephen C. Whalen (Principal Staff Eng.)  
**Date/s Tested:** 12/04/09 – 12/14/09, 01/08/10  
**Manufacturer/Location:** China  
**Sector/Group/Div.:** iDEN Mobile Devices  
**Date submitted for test:** 11/23/09  
**DUT Description:** TDMA: 236:310 WiDEN (76.1%), 81:120, 2:6, 1:12, and 1:6; M64QAM, M16QAM, and QPSK Modulations; 0.6 W Pulse Avg; MOTotalk: 114:120 8FSK; 0.85 W nominal (GPS and Bluetooth Capable).  
**Test TX mode(s):** Phone 1:3, Dispatch 1:6, Data 236:310 and MOTotalk:114:120  
**Max. Power output:** 0.64 W pulsed average conducted power (iDEN/WiDEN); 0.891 W (MOTotalk); 0.0025 W (Bluetooth)  
**Nominal Power:** 0.60 W pulsed average conducted power (iDEN); 0.85 W (MOTotalk); 0.001 W (Bluetooth)  
**Tx Frequency Bands:** 806-825, 896-902 MHz (iDEN); 902-928 MHz (MOTotalk); 2.402-2.480 GHz (Bluetooth)  
**Signaling type:** TDMA: QPSK, M16-QAM, M64-QAM; FHSS: 8FSK (PTT); BT  
**Model(s) Tested:** H88XAH6JR2AN  
**Model(s) Certified:** H88XAH6JR2AN  
**Serial Number(s):** 364VKUTFS8, 364VKUPGSJ  
**Classification:** General Population/Uncontrolled  
**Rule Part(s):** 15 & 90

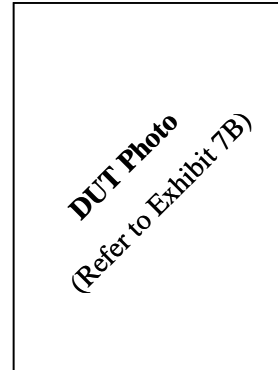

**Max. Calc. : 1-g Avg. SAR: 1.09 W/kg (Body); 10-g Avg. SAR: 0.79 W/kg (Body)**  
**Max. Calc. : 1-g Avg. SAR: 1.43 W/kg (Head); 10-g Avg. SAR: 1.00 W/kg (Head)**  
**Max. Calc. : 1-g Avg. SAR: 0.97 W/kg (Face); 10-g Avg. SAR: 0.69 W/kg (Face)**

The test results clearly demonstrate compliance with FCC General Population/Uncontrolled RF Exposure limits of 1.6 W/kg averaged over 1 gram per the requirements of 47 CFR 2.1093(d).  
 The test results clearly demonstrate compliance with ICNIRP (1998) Guidelines for limiting exposure in time-varying electric, magnetic, and electromagnetic fields (up to 300 GHz), Health Physics 74, 494-522 RF Exposure limits of 2.0 W/kg averaged over 10grams of contiguous tissue.

Based on the information and the testing results provided herein, the undersigned certifies that when used as stated in the operating instructions supplied, said product complies with the national and international reference standards and guidelines listed in section 3.0 of this report. This report shall not be reproduced without written approval from an officially designated representative of the Motorola EME Laboratory.  
 I attest to the accuracy of the data and assume full responsibility for the completeness of these measurements. This reporting format is consistent with the suggested guidelines of the TIA TSB-150 December 2004. The results and statements contained in this report pertain only to the device(s) evaluated.

Signature on file  
**Deanna Zakharia**  
**EMS EME Lab Senior Resource Manager,**  
**Laboratory Director**  
  
**Approval Date:** 01/13/10

**Certification Date:** 01/13/10  
**Certification No.:** L1100101P

**Part 1 of 2**

1.0 Introduction.....4

2.0 Abbreviations / Definitions.....4

3.0 Referenced Standards and Guidelines .....4

4.0 SAR Limits .....5

5.0 SAR Result Scaling Methodology .....5

6.0 Description of Device Under Test (DUT) .....6

7.0 Optional Accessories and Test Criteria .....7

    7.1 Antennas .....7

    7.2 Batteries .....7

    7.3 Body worn Accessories .....7

    7.4 Audio Accessories .....8

8.0 Description of Test System.....8

    8.1 Description of Robotics/Probes/Readout Electronics.....8

    8.2 Description of Phantom(s) .....9

        8.2.1 Dual Flat Phantom .....9

        8.2.2 SAM Phantom.....9

        8.2.3 Elliptical Phantom.....9

    8.3 Description of Simulated Tissue.....9

9.0 Additional Test Equipment.....10

10.0 SAR Measurement System Verification.....11

    10.1 Equivalent Tissue Test Results .....11

    10.2 System Check Test Results.....12

11.0 Environmental Test Conditions .....12

12.0 DUT Test Methodology.....12

    12.1 Measurements .....13

    12.2 DUT Configuration(s).....13

    12.3 DUT Positioning Procedures .....13

        12.3.1 Body .....13

        12.3.2 Head .....13

        12.3.3 Face .....13

    12.4 DUT Test Plan .....13

        12.4.1 General Test Flowchart.....14

13.0 DUT Test Data.....17

    13.1 Test Flowchart Data Summary 806-825MHz.....17

    13.2 806 -825MHz Band Test Data .....21

    13.3 Test Flowchart Data Summary 896-902MHz.....26

    13.4 896 -902MHz Band Test Data .....30

    13.5 MOTotalk Test Flowchart Data Summary 902-928MHz .....35

    13.6 MOTotalk Test Data .....37

    13.7 Shorten Scan Results .....40

14.0 Conclusion .....40

**Part 1 of 2 Continued**

**APPENDICES**

A Measurement Uncertainty .....41  
 B Probe Calibration Certificates.....44

**Part 2 of 2**

C Dipole Calibration Certificates .....2  
 D Test System Verification Scans .....9  
 E DUT Scans (Shortened Scan and Highest SAR configurations) .....18  
 F DUT Scans .....23  
 G DUT Supplementary Data (Power Slump) .....50  
 H DUT Test Position Photos .....52  
 I DUT and Body worn Accessory Photos .....53

**Report Revision History**

Date	Revision	Comments
01/13/2010	O	Original Release

## 1.0 Introduction

This report details the utilization, test setup, test equipment, and test results of the Specific Absorption Rate (SAR) measurements performed at the EMS EME Test Laboratory for model number H88XAH6JR2AN and FCC ID: IHDP56KY1. The results herein reflect prototype test results.

## 2.0 Abbreviations / Definitions

BT: Bluetooth  
CNR: Calibration Not Required  
DUT: Device Under Test  
FHSS: Frequency Hopping Spread Spectrum  
FSK: Frequency Shift Keying  
iDEN: Integrated Dispatch Enhanced Network  
ISM: Industrial, Scientific and Medical  
NA: Not Applicable  
PTT: Push to Talk  
QPSK: Quadrature Phase-Shift Keying  
QAM: Quadrature Amplitude Modulation  
SMR: Specialized Mobile Radio  
SAR: Specific Absorption Rate  
TDMA: Time Division Multiple Access

Audio accessories: These accessories allow communication while the DUT is worn on the body.

Body worn accessories: These accessories allow the DUT to be worn on the body of the user.

Maximum Power: Defined as the upper limit of the production line final test station.

## 3.0 Referenced Standards and Guidelines

This product is designed to comply with the following applicable national and international standards and guidelines.

- IEC62209-1\*(2005) Procedure to determine the specific absorption rate (SAR) for hand-held devices used in close proximity to the ear (frequency range of 300 MHz to 3 GHz)
- United States Federal Communications Commission, Code of Federal Regulations; Rule Part 47CFR § 2.1093 sub-part J:1999
- Federal Communications Commission, “Evaluating Compliance with FCC Guidelines for Human Exposure to Radio frequency Electromagnetic Fields”, OET Bulletin 65, Supplement C (Edition 01-01), FCC, Washington, D.C.: June 2001.
- IEEE 1528\*(2003), Recommended Practice for Determining the Peak Spatial-Average Specific Absorption Rate (SAR) in the Human Head from Wireless Communications Devices: Measurement Techniques
- American National Standards Institute (ANSI) / Institute of Electrical and Electronics Engineers (IEEE) C95. 1-1992
- Institute of Electrical and Electronics Engineers (IEEE) C95.1-2005
- International Commission on Non-Ionizing Radiation Protection (ICNIRP) 1998

- Ministry of Health (Canada) Safety Code 6 (1999), Limits of Human Exposure to Radio frequency Electromagnetic Fields in the Frequency Range from 3 kHz to 300 GHz
- Australian Communications Authority Radio communications (Electromagnetic Radiation - Human Exposure) Standard (2003)
- ANATEL, Brazil Regulatory Authority, Resolution No. 303 of July 2, 2002 "Regulation of the limitation of exposure to electrical, magnetic, and electromagnetic fields in the radio frequency range between 9kHz and 300 GHz." and "Attachment to resolution # 303 from July 2, 2002"
- Draft of IEC62209-2 Ed.1, Human Exposure to Radio Frequency Fields from Handheld and Body-Mounted Wireless Communication Devices – Human models, Instrumentation, and Procedures Part 2: Procedure to determine the specific absorption rate (SAR) for mobile wireless communication devices used in close proximity to the human body (frequency range of 30MHz to 6GHz), revised on Oct 3, 2008.

\* The IEC62209-1 and IEEE1528 are applicable for hand-held devices used in close proximity to the ear only.

**4.0 SAR Limits**

**TABLE 1**

EXPOSURE LIMITS	SAR (W/kg)	
	(General Population / Uncontrolled Exposure Environment)	(Occupational / Controlled Exposure Environment)
Spatial Average - ANSI - (averaged over the whole body)	0.08	0.4
Spatial Peak - ANSI - (averaged over any 1-g of tissue)	1.6	8.0
Spatial Peak – ICNIRP/ANSI - (hands/wrists/feet/ankles averaged over 10-g)	4.0	20.0
Spatial Peak - ICNIRP - (Head and Trunk 10-g)	2.0	10.0

**5.0 SAR Result Scaling Methodology**

The calculated 1-gram and 10-gram averaged SAR results indicated as “Max Calc. 1g-SAR” and “Max Calc.10g-SAR” in the data tables is determined by scaling the measured SAR to account for power leveling variations and power slump. A table and graph of output power versus time is provided in APPENDIX G. For this device the “Max Calc. 1g-SAR” and “Max Calc.10g-SAR” are scaled using the following formula:

$$Max\_Calc = SAR\_meas \cdot 10^{\frac{-Drift}{10}} \cdot \frac{P\_max}{P\_int} \cdot DC$$

- P\_max = Maximum Power (W)
- P\_int = Initial Power (W)
- Drift = DASY drift results (dB)
- SAR\_meas = Measured 1-g or 10-g Avg. SAR (W/kg)
- DC = Transmission mode duty cycle in % where applicable
- 50% duty cycle is applied for PTT operation

Note: for conservative results, the following are applied:

If  $P_{int} > P_{max}$ , then  $P_{max}/P_{int} = 1$ .

Drift = 1 for positive drift

Additional SAR scaling was applied using the methodologies outlined in FCC KDB450824 using tissue sensitivity values. SAR was scaled for conditions where the tissue permittivity was measured above the nominal target and for tissue conductivity that was measured below the nominal target.

## 6.0 Description of Device Under Test (DUT)

FCC ID: IHDP56KY1 model H88XAH6JR2AN is a digital multi-service data capable devices that employs time division multiplexing with duty cycles of 16.67% for Voice (Dispatch), 16.67% (1:6) or 33.00%(1:3) for Interconnect or Circuit Data, 67.5% (81:120) for Packet Data and 76.1% (236:310) for WiDEN. Possible modulation formats are QPSK, M16-QAM, or M64-QAM. All voice modes employ M16-QAM modulation, and are interleaved as 1:6 (for Dispatch PTT or Interconnect) or 1:3 (maximum for Interconnect). Split 1:3 Interconnect is operated at a 16.67% duty cycle, but because there will be two pulses in each 90-msec frame, the overall interleave is 2:6. Data transmissions employ QPSK, M16-QAM, and M64-QAM modulations, and have a maximum duty cycle of 67.50% (Packet Data) to a maximum of 76.1% for WiDEN mode. Packet Data and WiDEN operations are possible with-and-without connection to an external data device (via a data cable or Bluetooth link). All iDEN modes (Interconnect, Dispatch, and Data) are available in both the 800 and 900 MHz SMR bands, and are also supported in the Narrowband PCS. This device also possesses MOTOtalk, which is a Part 15 service, employing Frequency Hopping Spread Spectrum technology in the 900 MHz ISM band. MOTOtalk emissions have a duty cycle of 95.0% (114:120), and uses 8FSK modulation. Only dispatch (i.e. PTT) operation is possible when operating in this mode. The unit may be used at the abdomen in this mode (with applicable audio accessories) or held in front of the face. The low-audio earpiece mode has been locked out in software. There is no simultaneous operation with iDEN modes.

This device also incorporates a Class 2 Bluetooth (BT) device which is a Frequency Hopping Spread Spectrum (FHSS) technology with a 76.5% maximum duty cycle. Bluetooth is a short range wireless protocol used for communication between users. Users link to each other through an Ad-Hock network of pico-nets. The pico-net is the basic communication cell, which is formed by a "master" and up to 7 "slaves."

This device will be marketed to and used by the general population. This device may be used while held against the head in voice mode, in front of the face in PTT mode, and against the body in phone, dispatch, MOTOtalk, Data and BT modes.

FCC ID: IHDP56KY1 is capable of operating in the 806-825 MHz and 896-902MHz bands for iDEN modes, 902-928MHz band for MOTOtalk mode and 2.402-2.480GHz band for BT. The nominal conducted power is 0.60 watts pulsed averaged in 806-825MHz and 896-902MHz bands, 0.850 watts in the MOTOtalk band and 0.001 watts in the BT band. The maximum conducted output power is 0.640 watts pulsed average, 0.891 watts and 0.0025 watts respectively as defined by the upper limit of the production line final test station.

**7.0 Optional Accessories and Test Criteria**

FCC ID: IHDP56KY1 is offered with optional accessories. All accessories were individually evaluated during the test plan creation to determine if testing was required. The following sections identify the test criteria and details for each accessory category.

**7.1 Antennas**

The table below summarizes the antennas, antenna descriptions, test status and separation distances.

**TABLE 2**

Antenna Models	Description	Tested	* Separation distances between DUT and phantom surface for given test configurations		
			Body Test Configuration		Face Test Configuration DUT @ 2.5cm
			Tested Carry Accessories	2.5cm Assessment DUT @ 2.5cm	
85009260001	Internal ¼ wave, 806-825MHz (-1.3dBi), 896-902MHz (0.04dBi), 902-928MHz (0.06dBi)	Yes	NA	25-25mm	25-25mm
85009258001	Internal ¼ wave 2.402-2.481GHz (-1.0dBi)	**No	**NA	**NA	**NA

\* The 1st number indicates the minimum separation distance that was measured at the bottom of the DUT while the second number reflects the separation distance measured at the top of the DUT. Refer to Exhibit 7B for illustration of distances.

\*\* BT testing is not required per FCC KDB648474.

**7.2 Batteries**

All batteries were tested. The table below lists the batteries, descriptions and test status.

**TABLE 3**

Battery Models	Description	Tested	Comments
SNN5795A	Li Ion BK60 Standard battery	Yes	Requires battery cover NTN2565XXXXA
SNN5793A	Li Ion BK10 Extended battery	Yes	Requires battery cover NTN2566XXXXA

**7.3 Body worn Accessories**

The body worn accessory was tested. The table below lists the body worn, description, test status and separation distances. This section is not applicable since no body worn accessories are available.

**TABLE 4**

Body worn Models	Description	Tested	* Separation distances between DUT and phantom surface. (mm)	Comments
NA	NA	NA	NA	NA

\* The 1st number indicates the minimum separation distance that was measured at the bottom of the carry holder or DUT while the second number reflects the separation distance measured at the top of the carry holder or DUT. Refer to Exhibit 7B for illustration of distances.

**7.4 Audio/Data Cable Accessories**

The audio accessories were tested. The table below lists the audio accessories, descriptions and test status.

**TABLE 5**

Audio Acc. Models	Description	Tested	Comments
Headsets w/ Microphone (Applicable for Body testing only)			
NNTN5211B	2-wire surveillance headset (iDEN), PTT	Yes	
NNTN6312A	3-wire surveillance headset (iDEN), PTT	Yes	
NNTN5330B	Headset PTT, Earbud (iDEN) – 2.5mm	Yes	
Data Cable (Applicable for Body testing only)			
SKN6238A	USB Data cable	Yes	

**8.0 Description of Test System**



**8.1 Descriptions of Robotics/Probes/Readout Electronics**

The laboratory utilizes a Dosimetric Assessment System (DASY4™) SAR measurement system Version 4.7 build 80 manufactured by Schmid & Partner Engineering AG (SPEAG™), of Zurich Switzerland. The test system consists of a Stäubli RX90L robot, DAE3, and ES3DV2 E-field probe. The DASY4™ system is operated per the instructions in the DASY4™ Users Manual. The complete manual is available directly from SPEAG™. All measurement equipment used to assess EME SAR compliance was calibrated according to ISO/IEC 17025 A2LA guidelines. Section 9.0 presents additional test equipment information. Appendices B and C present the applicable calibration certificates. The E-field probe first scans a coarse grid over a large area inside the phantom in order to locate the interpolated maximum SAR distribution. After the coarse scan measurement, the probe is automatically moved to a position at the interpolated maximum. The subsequent scan can directly use this position as reference for the cube evaluations.

**8.2 Description of Phantom(s)**

**8.2.1 Dual Flat Phantom**

Not applicable

**8.2.2 SAM Phantom**

**TABLE 6**

Phantom ID (s)	Material Parameters	Material Thickness (mm)	Support Structure Material	Loss Tangent (wood)
SAMTP1234	200MHz -3GHz; Er = 5, Loss Tangent = ≤0.05	2mm +/- 0.2mm	Wood	< 0.05

**8.2.3 Elliptical Flat Phantom**

**TABLE 7**

Phantom ID (s)	Material Parameters	Phantom Dimensions LxWxD (mm)	Material Thickness (mm)	Support Structure Material	Loss Tangent (wood)
OVAL1019	300MHz -6GHz; Er = 4+/- 1, Loss Tangent = ≤0.05	600x400x190	2mm +/- 0.2mm	Wood	< 0.05

**8.3 Description of Simulated Tissue**

The simulated tissue used is compliant to that specified in FCC Supplement C (Edition 01-01) to OET Bulletin 65 (Edition 97-01) and IEEE Std 1528 - 2003 "Recommended Practice for Determining the Peak Spatial-Average Specific Absorption Rate (SAR) in the Human Head from Wireless Communications Devices: Measurement Techniques". The simulated tissue used is also compliant to that specified in IEC62209-1 (2005) and adopted by CENELEC as EN62209-1 (2006).

The sugar based simulate tissue is produced by placing the correct measured amount of De-ionized water into a large container. Each of the dried ingredients are weighed and added to the water carefully to avoid clumping. If the solution has a high sugar concentration the water is pre-heated to aid in dissolving the ingredients. For Diacetin and similar type simulates, sugar and HEC ingredients are not needed. The solution is mixed thoroughly, covered, and allowed to sit overnight prior to use.

**Simulated Tissue Composition (by mass)****TABLE 8**

% of listed ingredients	835MHz		900MHz	
	Head	Body	Head	Body
Sugar	57.0	44.9	56.5	44.9
Diacetin	0	0	0	0
De ionized -Water	40.45	53.06	40.95	53.06
Salt	1.45	0.94	1.45	0.94
HEC	1.0	1.0	1.0	1.0
Bact.	0.1	0.1	0.1	0.1

Reference section 10.1 for target parameters

**9.0 Additional Test Equipment**

The table below lists additional test equipment used during the SAR assessment.

**TABLE 9**

Equipment Type	Model	Serial	Calibration Due
Power Meter (Agilent)	E4419B	MY40330364	7/14/2010
Power Meter (Agilent)	E4418B	US39251266	2/26/2010
E-Series Avg. Power Sensor (Agilent)	E9301B	MY41495593	2/18/2010
E-Series Avg. Power Sensor (Agilent)	E9301B	MY41495594	2/18/2010
Power Sensor (Agilent)	8482B	3318A06774	2/27/2010
Bi-Directional Coupler (NARDA)	3020A	40295	6/9/2010
Bi-Directional Coupler (NARDA)	3022	77115	3/20/2010
Signal Generator (Agilent)	E4438C	MY42082269	6/3/2011
AMP (Amplifier Research)	10WD1000	28782	CNR
Dickson Temperature Recorder	TM125	1195889	2/14/2010
Omega Digital Thermometer with J Type TC Probe	HH202A	18800	10/10/2010
Omega Digital Thermometer with J Type TC Probe	HH202A	18801	4/1/2010
Omega Digital Thermometer with J Type TC Probe	HH202A	18812	5/22/2010
Agilent PNA-L Network Analyzer	N5230A	MY45001092	5/22/2010
Dielectric Probe Kit (HP)	85070C	US99360076	CNR
Speag Dipole	D900V2	85	8/25/2010

**10.0 SAR Measurement System Verification**

The SAR measurements were conducted with probe model/serial number ES3DV2/SN3147. The system performance check was conducted daily and within 24 hours prior to testing. DASY output files of the probe/dipole calibration certificates and system performance test results are included in appendices B, C, D respectively.

Dipole validation scans using head tissue equivalent medium are provided in APPENDIX D. The EMS EME lab validated the dipole to the applicable IEEE 1528-2003 system performance targets. Within the same day system validation was performed using FCC body tissue parameters to generate the system performance target values for body at the applicable frequency. The results of the EMS EME system performance validation are provided herein.

**10.1 Equivalent Tissue Test Results**

Simulated tissue prepared for SAR measurements is measured daily and within 24 hours prior to actual SAR testing to verify that the tissue is within +/- 5% of target parameters at the center of the transmit band. This measurement is done using the applicable equipment indicated in section 9.0. The table below summarizes the measured tissue parameters used for the SAR assessment.

**TABLE 10**

Frequency (MHz)	Tissue Type	Conductivity Target & Range (S/m)	Dielectric Constant Target & Range	Conductivity Meas. (S/m)	Dielectric Constant Meas.	Tested Date
815.5	FCC Body	0.97 (0.92-1.01)	55.3 (52.5-58.0)	0.97	53.6	12/10/09
				0.97	53.4	12/11/09
				0.97	53.4	12/14/09
815.5	IEEE/ IEC Head	0.90 (0.85-0.94)	41.6 (39.5-43.6)	0.88	42.3	12/04/09
				0.90	41.6	12/05/09
899	FCC Body	1.05 (0.99-1.10)	55.0 (52.3-57.7)	1.06	52.7	12/11/09
899	IEEE/ IEC Head	0.97 (0.92-1.01)	41.5 (39.4-43.5)	0.96	41.3	12/04/09
				0.97	41.5	12/05/09
				0.95	39.7	01/08/10
900	FCC Body	1.05 (0.99-1.10)	55.0 (52.3-57.7)	1.06	52.8	12/10/09
				1.06	52.6	12/11/09
				1.06	52.6	12/14/09
900	IEEE/ IEC Head	0.97 (0.92-1.01)	41.5 (39.4-43.5)	0.96	41.3	12/04/09
				0.97	41.5	12/05/09
				0.95	39.7	01/08/10
915	FCC Body	1.06 (1.00-1.11)	55.0 (52.3-57.7)	1.07	52.4	12/14/09
915	IEEE/ IEC Head	0.98 (0.93-1.02)	41.5 (39.4-43.5)	0.98	41.5	12/05/09

**10.2 System Check Test Results**

System performance checks were conducted each day during the SAR assessment. The results are normalized to 1W. APPENDIX D explains how the targets were set and includes DASY plots for each day during the SAR assessment. The table below summarizes the daily system check results used for the SAR assessment.

**TABLE 11**

Probe Serial #	Tissue Type	Probe Cal Date	Dipole Kit / Serial #	Reference SAR @ 1W (W/kg)	System Check Test Results when normalized to 1W (W/kg)	Tested Date
3147	IEEE/ IEC Head	2/13/2009	SPEAG D900V2 /085	11.50+/- 10%	11.44	12/04/09
					11.60	12/05/09
					11.48	01/08/10
3147	FCC Body	2/13/2009	SPEAG D900V2 /085	11.30 +/- 10%	11.48	12/10/09
					11.52	12/11/09
					11.56	12/14/09

Note: See APPENDIX D for an explanation of the reference SAR targets stated above.

**11.0 Environmental Test Conditions**

The EME Laboratory ambient environment is well controlled resulting in very stable simulated tissue temperature and therefore stable dielectric properties. Simulated tissue temperature is measured prior to each scan to insure it is within +/- 2°C of the temperature at which the dielectric properties were determined. The liquid depth within the phantom used for measurements was at least 15cm. Additional precautions are routinely taken to ensure the stability of the simulated tissue such as covering the phantoms when scans are not actively in process in order to minimize evaporation. The lab environment is continuously monitored. The table below presents the range and average environmental conditions during the SAR tests reported herein:

**TABLE 12**

	Target	Measured
Ambient Temperature	18 - 25 °C	Range: 20.1-22.2°C Avg. 21.4°C
Relative Humidity	30 - 70 %	Range: 25.5-68.5% Avg. 53.8%
Tissue Temperature	NA	Range: 19.9-20.6°C Avg. 20.2°C

The EME Lab RF environment uses a Spectrum Analyzer to monitor for extraneous large signal RF contaminants that could possibly affect the test results. If such unwanted signals are discovered the SAR scans are repeated.

**12.0 DUT Test Methodology**

Per FCC KDB648474 BT testing is not required.

- a) BT max power (2.5mW) < 12mW (Pref @ 2.45GHz)
- b) Antenna separation distances is less than 2.5cm.
- c) SAR at the body (1.09 W/kg) is less than 1.2 W/kg.

## **12.1 Measurements**

SAR measurements were performed using the DASY system described in section 8.0 using coarse and 5x5x7 zoom scan. Elliptical flat and SAM phantoms filled with applicable simulated tissue were used for body, head and face testing.

## **12.2 DUT Configuration(s)**

The DUT is a portable device with iDEN (QPSK, M16-QAM, M64-QAM), MOTOtalk and BT signaling operational at the relevant body, head and face as described in section 6.0 while using the applicable accessories listed in section 7.0.

## **12.3 Device Positioning Procedures**

The positioning of the device for each body location is described below and illustrated in APPENDIX H.

### **12.3.1 Body**

The DUT was positioned with its' back and front sides separated 2.5cm from the phantom because no body worn accessory is available and to satisfy the conditions noted in the safety section of the manual.

### **12.3.2 Head**

The DUT was placed against the right and left ears of the SAM phantom in the check touch and tilt positions.

### **12.3.3 Face**

The DUT was positioned with its' front side separated 2.5cm from the phantom.

## **12.4 Test Plan**

The modes of operation identified in section 6.0 were used to develop the test plan using the highest duty cycle where applicable. All accessories listed in section 7.0 of this report were evaluated and only those identified for testing were used to develop the SAR test plan for this product.

An Expanded One Factor at A Time (OFAT) method was applied to develop the SAR test plan for this product. The following flowcharts identify the general approach to the test sequences for body, head and face positions.

**12.4.1 General Test Flowchart**

DUT Body Test Methodology  
(General flowchart)

Flowchart Objectives  
Body

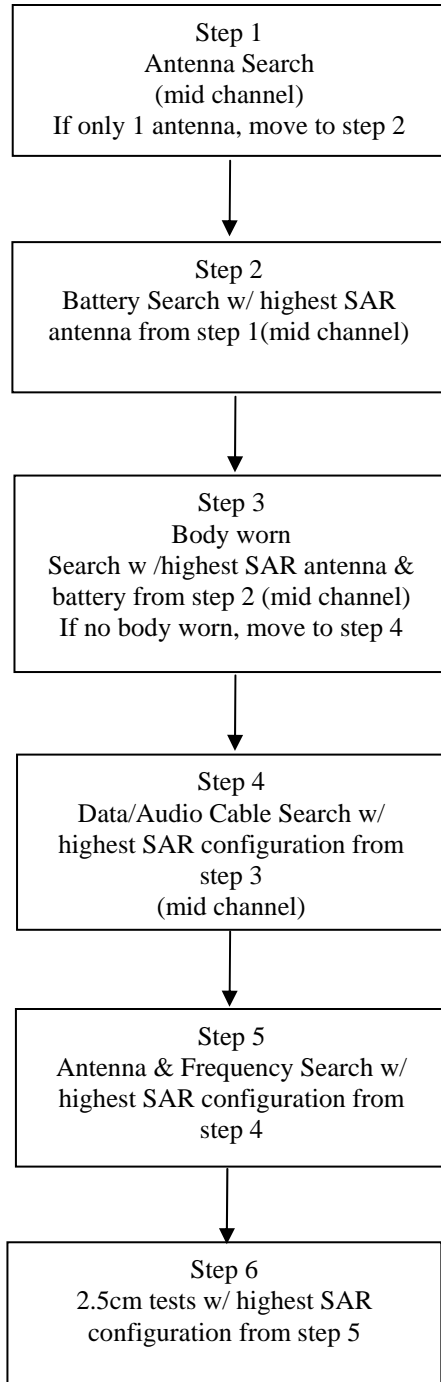

**Step 1** - Determine the highest SAR antenna. If only 1 antenna then move to step 2.

**Step 2** – Determine if optional batteries cause the SAR values to increase. All tests in step 2 are positioned @ 2.5cm from phantom.

**Step 3** - Determine if optional body worn carry case causes the SAR value to increase. All tests in step 3 use the same holster from steps 1 & 2 along with the highest SAR antenna (mid channel) and battery. If no body worn then move to step 4.

**Step 4** – Determine if the optional data/audio accessories causes the SAR value to increase. All tests in step 4 use the overall highest SAR combination of antenna (mid channel) and battery from the steps above.

**Step 5** – Determine if the low & mid channels for the antenna cause the SAR values to increase. All tests in step 5 use the overall highest SAR combination of battery and data/audio from the steps above.

**Step 6** – Determine if the DUT positioned at 2.5cm from the body (front and back) causes the SAR value to increase. All tests in step 6 use the overall highest SAR frequency, battery and data/audio from the steps above.

DUT Head Test Methodology  
(General flowchart)

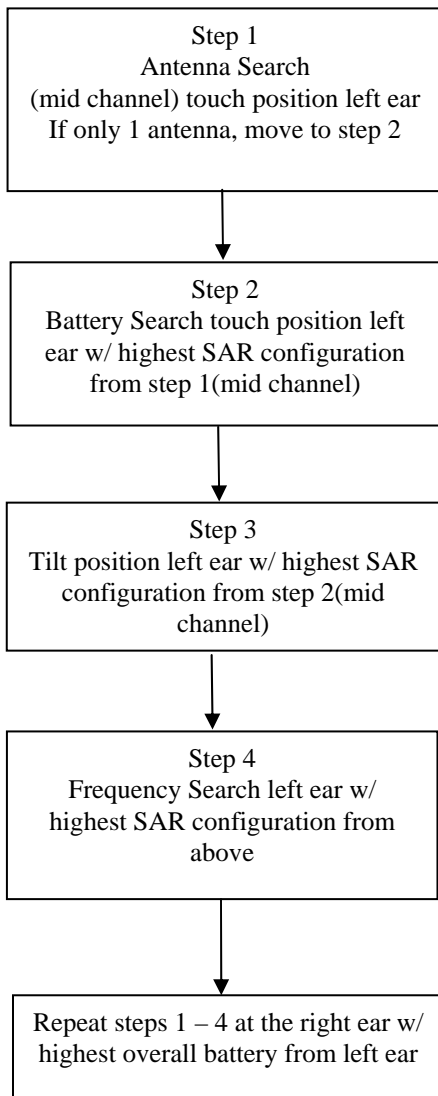

Flowchart Objectives  
Head

**Step 1** – Determine the highest SAR antenna. If only 1 antenna then move to step 2.

**Step 2** – Determine if the optional batteries cause the SAR values to change.

**Step 3** – Determine if the tilt position causes the SAR value to change. All tests in step 3 use the overall highest SAR combination (mid channel) from the steps above.

**Step 4** – Determine if the low & high channels cause the SAR value to change. All tests in step 4 use the overall highest SAR combination from the steps above.

DUT Face Test Methodology  
(General flowchart)

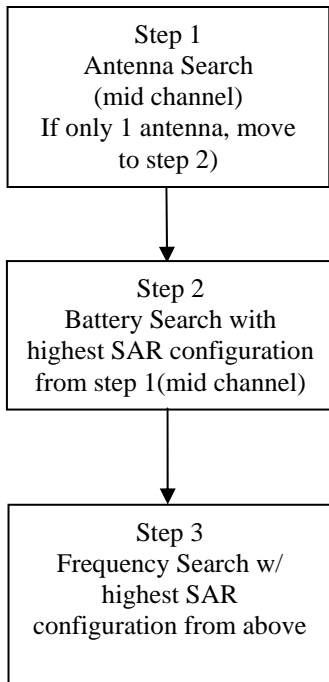

Flowchart Objectives  
Face

**Step 1** – Determine the highest SAR antenna. If only 1 antenna then move to step 2.

**Step 2** – Determine if the optional batteries accessory cause the SAR value to change above.

**Step 3** – Determine if the low, mid & high channels cause the SAR value to change. All tests in step 3 use the overall highest SAR combination from the steps above.

13.0 DUT Test Data

13.1 Test Flowchart Data Summary 806-825MHz Band

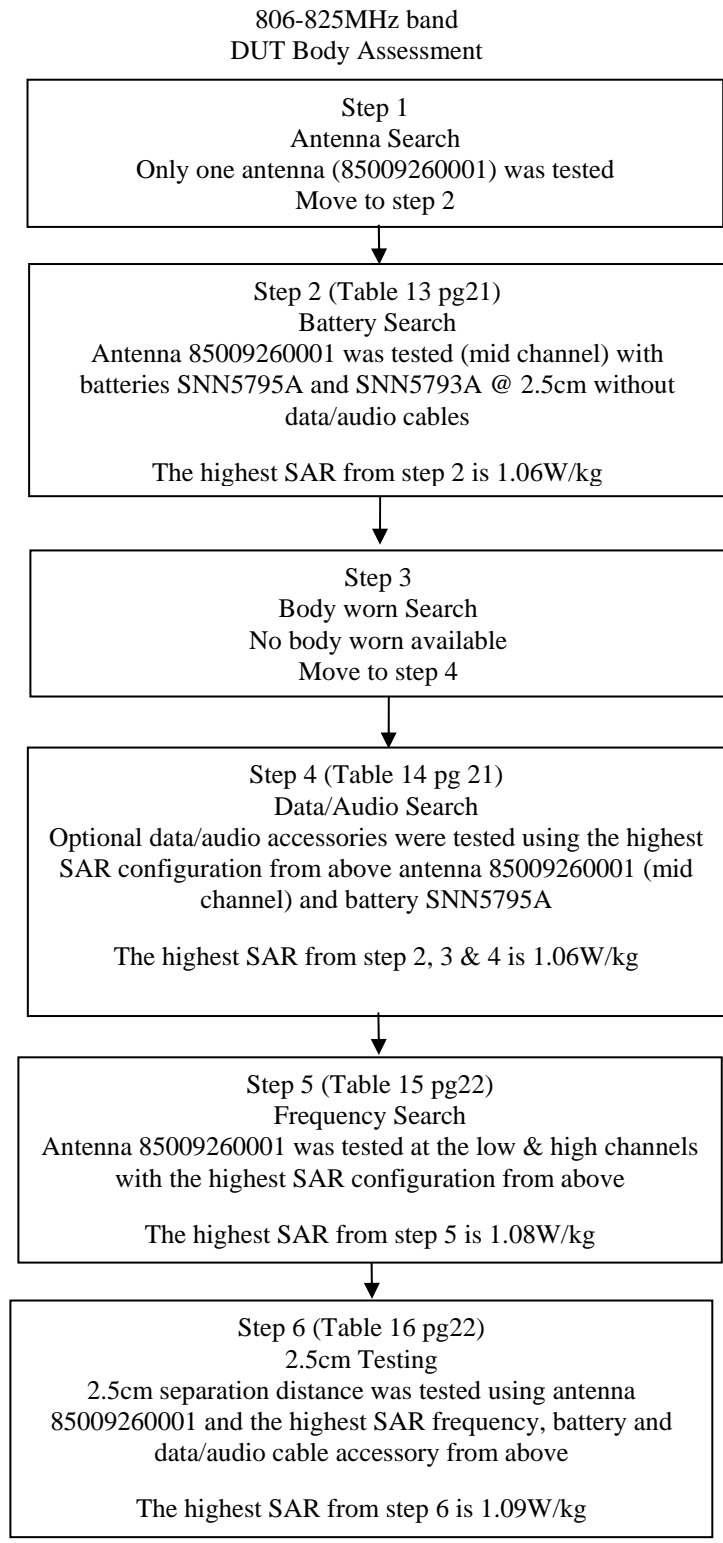

**The highest body SAR from above is  
1.09W/kg**

806-825MHz band  
DUT Head Assessment – Left Ear

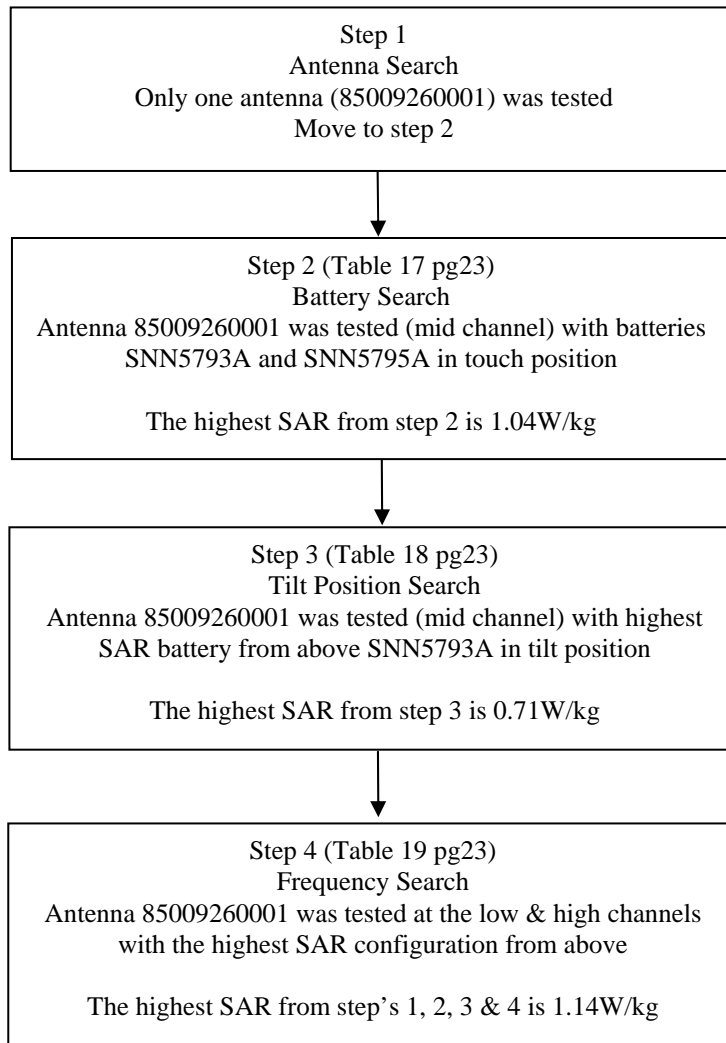

**The highest Head SAR – Left Ear from  
above is 1.14W/kg**

806-825MHz band  
DUT Head Assessment – Right Ear

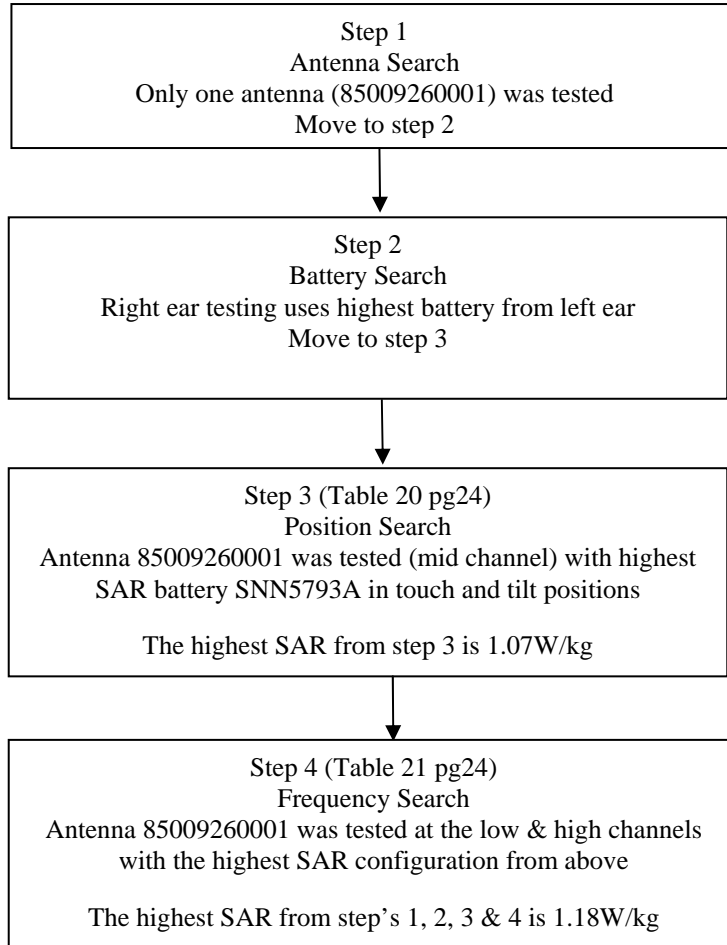

**The highest Head SAR – Right Ear from above is 1.18W/kg**

806-825MHz band  
DUT Face Assessment

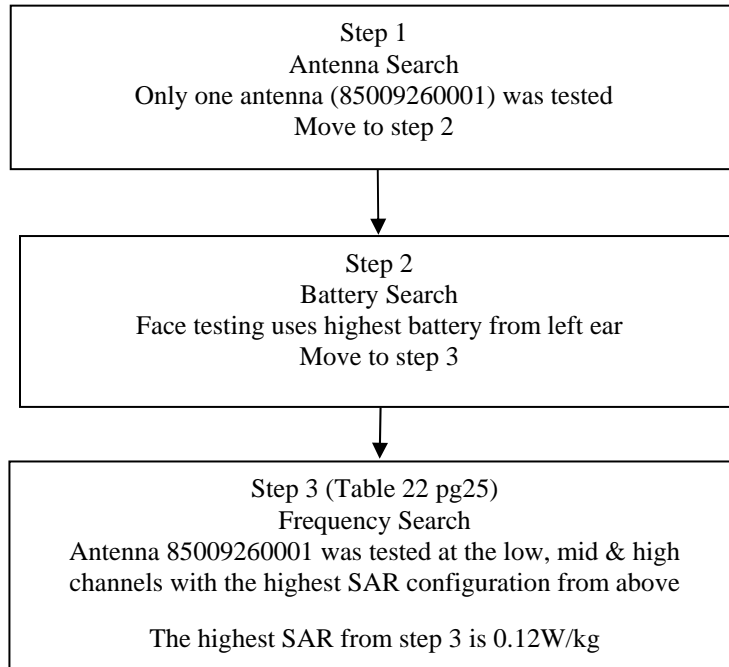

**The highest Face SAR from above is  
0.12W/kg**

**13.2 806-825MHz Band Test Data**

**Assessments at the Body (236:310 Data mode, 1:3 Phone mode)**

**Assessment of the offered antenna (Test Flowchart pg 17 step 1);** Antenna search is not required because only one antenna is offered for 806-825MHz bands. Move to step 2.

**Assessment of the offered batteries (Test Flowchart pg 17 step 2);** The optional batteries were tested. These tests were conducted at mid channel using antenna (85009260001) with DUT positioned 2.5cm from phantom and without a data cable. The highest SAR result from the table below is provided in APPENDIX F Section 1.0 – 806-825MHz Band Assessment of the offered batteries.

**TABLE 13**

806-825MHz Band Assessments at Body (236:310 data mode) – Assessment of offered batteries												
Run Number/ SN	Antenna	Freq. (MHz)	Battery	Test position	Carry Case	Additional attachments	Initial Power (W)	SAR Drift (dB)	Meas. 1g-SAR (W/kg)	Meas. 10g-SAR (W/kg)	Max Calc. 1g-SAR (W/kg)	Max Calc. 10g-SAR (W/kg)
MeC-Ab-091210-06 / 364VKUTFS8	85009260001 (internal)	815.5125	SNN5795A w/ NTN2565xxxA	DUT back 2.5cm	None	None	0.623	-0.586	0.890	0.646	1.06	0.77
MeC-Ab-091210-07 / 364VKUTFS8	85009260001 (internal)	815.5125	SNN5793A w/ NTN2566xxxA	DUT back 2.5cm	None	None	0.626	-0.233	0.738	0.542	0.81	0.59

**Assessment of the offered body worn accessory (Test Flowchart pg 17 step 3);** Body worn accessory search is not required because no body worn is offered. Move to step 4.

**Assessment of the offered data/audio cable accessories (Test Flowchart pg 17 step 4);** The optional data/audio cables were tested in their applicable modes (236:310, 1:3) at mid channel using highest configuration antenna (85009260001), battery (SNN5795A) with DUT positioned 2.5cm from phantom. The highest SAR result from the table below is provided in APPENDIX F Section 2.0 - 806-825MHz Band Assessment of the offered data/audio cables.

**TABLE 14**

806-825MHz Band Assessments at Body (236:310 data mode) – Assessment of offered data cable												
Run Number/ SN	Antenna	Freq. (MHz)	Battery	Test position	Carry Case	Additional attachments	Initial Power (W)	SAR Drift (dB)	Meas. 1g-SAR (W/kg)	Meas. 10g-SAR (W/kg)	Max Calc. 1g-SAR (W/kg)	Max Calc. 10g-SAR (W/kg)
MeC-Ab-091210-08 / 364VKUTFS8	85009260001 (internal)	815.5125	SNN5795A w/ NTN2565xxxA	DUT back 2.5cm	None	SKN6238A (USB Cable)	0.625	-0.640	0.705	0.525	0.85	0.63
806-825MHz Band Assessments at Body (1:3 phone mode) – Assessment of offered audio accessory												
MeC-Ab-091210-09 / 364VKUTFS8	85009260001 (internal)	815.5125	SNN5795A w/ NTN2565xxxA	DUT back 2.5cm	None	NNTN5330B PTT Headset, Earbud	0.624	-0.057	0.425	0.314	0.44	0.32
MeC-Ab-091210-10 / 364VKUTFS8	85009260001 (internal)	815.5125	SNN5795A w/ NTN2565xxxA	DUT back 2.5cm	None	NNTN5211B 2-wire Surveillance Headset	0.628	-0.002	0.401	0.293	0.41	0.30
MeC-Ab-091210-11 / 364VKUTFS8	85009260001 (internal)	815.5125	SNN5795A w/ NTN2565xxxA	DUT back 2.5cm	None	NNTN6312A 3-wire Surveillance Headset	0.625	-0.121	0.449	0.324	0.47	0.34

**Assessments at the Body (236:310 Data mode)**

**Assessment of frequency band edges of the offered antenna (Test Flowchart pg 17 step 5);** The frequency band edges (low and high) were tested using the highest configuration antenna (85009260001), battery (SNN5795A), with DUT positioned 2.5cm from phantom without a data cable. The highest SAR result from the table below is provided in APPENDIX F Section 3.0 - 806-825MHz Band Assessment of frequency band edges of the offered antenna.

**TABLE 15**

806-825MHz Band Assessments at Body (236:310 data mode) -Assessment of frequency band edges of the offered antenna												
Run Number/ SN	Antenna	Freq. (MHz)	Battery	Test position	Carry Case	Additional attachments	Initial Power (W)	SAR Drift (dB)	Meas. 1g-SAR (W/kg)	Meas. 10g-SAR (W/kg)	Max Calc. 1g-SAR (W/kg)	Max Calc. 10g-SAR (W/kg)
JsT-Ab-091211-04 / 364VKUTFS8	85009260001 (internal)	806.012 5	SNN5795A w/ NTN2565xxx A	DUT back 2.5cm	None	None	0.636	-0.591	0.927	0.674	1.08	0.79
JsT-Ab-091211-05 / 364VKUTFS8	85009260001 (internal)	824.987 5	SNN5795A w/ NTN2565xxx A	DUT back 2.5cm	None	None	0.638	-0.671	0.846	0.615	1.00	0.73

**Assessment without body worn accessory at 2.5cm (Test Flowchart pg 17 step 6);** The highest SAR test configuration (antenna 85009260001, frequency 806.0125MHz, battery SNN5795A and without data cable) was selected to assess this device at 2.5cm with the front and back of the device facing the phantom. The highest SAR result from the table below is provided in APPENDIX F Section 4.0 - 806-825MHz Band Assessment without body worn accessory at 2.5cm.

Note: The 2.5cm assessments included the following configurations:

- Back of the device facing the phantom, positioned at 2.5cm from the phantom surface.
- Front of the device facing the phantom, positioned at 2.5cm from the phantom surface.

**TABLE 16**

806-825MHz Band Assessments at Body (236:310 data mode) - Assessment at 2.5cm												
Run Number/ SN	Antenna	Freq. (MHz)	Battery	Test position	Carry Case	Additional attachments	Initial Power (W)	SAR Drift (dB)	Meas. 1g-SAR (W/kg)	Meas. 10g-SAR (W/kg)	Max Calc. 1g-SAR (W/kg)	Max Calc. 10g-SAR (W/kg)
JsT-Ab-091211-04 / 364VKUTFS8	85009260001 (internal)	806.012 5	SNN5795A w/ NTN2565xxx A	DUT back 2.5cm	None	None	0.636	-0.591	0.927	0.674	1.08	0.79
<b>**HvH-Ab- 091214-09 / 364VKUPGSJ</b>	85009260001 (internal)	806.012 5	SNN5795A w/ NTN2565xxx A	DUT back 2.5cm	None	None	0.625	-0.279	0.983	0.715	1.09	0.79
JsT-Ab-091211-06 / 364VKUTFS8	85009260001 (internal)	806.012 5	SNN5795A w/ NTN2565xxx A	DUT front 2.5cm	None	None	0.634	-0.504	0.784	0.571	0.90	0.66

\*\* Additional repeat scan of above with a different radio (SN 364VKUPGSJ).

**Assessments at the Head Left Ear (1:3 Phone mode)**

**Assessment of the offered antenna (Test Flowchart pg 18 step 1);** Antenna search is not required because only one antenna is offered for 806-825MHz bands. Move to step 2.

**Assessment of the offered batteries (Test Flowchart pg 18 step 2);** The optional batteries were tested. These tests were conducted at mid channel using antenna (85009260001) at the left ear touch position. The highest SAR result from the table below is provided in APPENDIX F Section 5.0 – 806-825MHz Band Assessment of the offered batteries.

**TABLE 17**

806-825MHz Band Assessments at LEAR (1:3 phone mode) – Assessment of offered batteries												
Run Number/ SN	Antenna	Freq. (MHz)	Battery	Test position	Carry Case	Additional attachments	Initial Power (W)	SAR Drift (dB)	Meas. 1g-SAR (W/kg)	Meas. 10g-SAR (W/kg)	Max Calc. 1g-SAR (W/kg)	Max Calc. 10g-SAR (W/kg)
JsT-Lear-091204-08 / 364VKUTFS8	85009260001 (internal)	815.512 5	SNN5795A w/ NTN2565xxx A	Cheek Touch	None	None	0.625	-0.259	0.908	0.642	0.99	0.70
<b>JsT-Lear-091204-11 / 364VKUTFS8</b>	85009260001 (internal)	815.512 5	SNN5793A w/ NTN2566xxx A	Cheek Touch	None	None	0.627	-0.079	1.000	0.705	1.04	0.73

**Assessment of the Position (Test Flowchart pg 18 step 3);** The tilt position was tested at mid channel using highest configuration antenna (85009260001) and battery (SNN5793A). The highest SAR result from the table below is provided in APPENDIX F Section 6.0 – 806-825MHz Band Assessment of the tilt position.

**TABLE 18**

806-825MHz Band Assessments at LEAR (1:3 phone mode) – Assessment of tilt position												
Run Number/ SN	Antenna	Freq. (MHz)	Battery	Test position	Carry Case	Additional attachments	Initial Power (W)	SAR Drift (dB)	Meas. 1g-SAR (W/kg)	Meas. 10g-SAR (W/kg)	Max Calc. 1g-SAR (W/kg)	Max Calc. 10g-SAR (W/kg)
<b>JsT-Lear-091204-10 / 364VKUTFS8</b>	85009260001 (internal)	815.512 5	SNN5793A w/ NTN2566xxx A	15° Tilt	None	None	0.626	0.030	0.698	0.502	0.71	0.51

**Assessment of frequency band edges of the offered antenna (Test Flowchart pg 18 step 4);** The frequency band edges (low and high) were tested using the highest configuration antenna (85009260001) and battery (SNN5793A). The highest SAR result from the table below is provided in APPENDIX F Section 7.0 - 806-825MHz Band Assessment of frequency band edges of the offered antenna.

**TABLE 19**

806-825MHz Band Assessments at LEAR (1:3 phone mode) -Assessment of frequency band edges of the offered antenna												
Run Number/ SN	Antenna	Freq. (MHz)	Battery	Test position	Carry Case	Additional attachments	Initial Power (W)	SAR Drift (dB)	Meas. 1g-SAR (W/kg)	Meas. 10g-SAR (W/kg)	Max Calc. 1g-SAR (W/kg)	Max Calc. 10g-SAR (W/kg)
JsT-Lear-091204-12 / 364VKUTFS8	85009260001 (internal)	806.012 5	SNN5793A w/ NTN2566xxx A	Cheek Touch	None	None	0.635	-0.102	0.933	0.653	0.96	0.67
<b>JsT-Lear-091204-13 / 364VKUTFS8</b>	85009260001 (internal)	824.987 5	SNN5793A w/ NTN2566xxx A	Cheek Touch	None	None	0.638	-0.0292	1.13	0.788	1.14	0.80

**Assessments at the Head Right Ear (1:3 Phone mode)**

**Assessment of the offered antenna (Test Flowchart pg 19 step 1);** Antenna search is not required because only one antenna is offered for 806-825MHz bands. Move to step 2.

**Assessment of the offered batteries (Test Flowchart pg 19 step 2);** The highest battery from the left ear was used for right ear testing and therefore a battery search is not required. Move to step 3.

**Assessment of the positions (Test Flowchart pg 19 step 3);** The touch and tilt positions were tested using the highest battery (SNN5793A) from the left ear. These tests were conducted at mid channel using antenna (85009260001). The highest SAR result from the table below is provided in APPENDIX F Section 8.0 – 806-825MHz Band Assessment of the touch and tilt positions.

**TABLE 20**

806-825MHz Band Assessments at REAR (1:3 phone mode) – Assessment of touch and tilt position												
Run Number/ SN	Antenna	Freq. (MHz)	Battery	Test position	Carry Case	Additional attachments	Initial Power (W)	SAR Drift (dB)	Meas. 1g-SAR (W/kg)	Meas. 10g-SAR (W/kg)	Max Calc. 1g-SAR (W/kg)	Max Calc. 10g-SAR (W/kg)
CM-Rear-091204-19 / 364VKUTFS8	85009260001 (internal)	815.512 5	SNN5793A w/ NTN2566xxx A	Cheek Touch	None	None	0.623	-0.068	1.030	0.747	1.07	0.78
CM-Rear-091204-20 / 364VKUTFS8	85009260001 (internal)	815.512 5	SNN5793A w/ NTN2566xxx A	15° Tilt	None	None	0.621	-0.229	0.688	0.491	0.75	0.53

**Assessment of frequency band edges of the offered antenna (Test Flowchart pg 19 step 4);** The frequency band edges (low and high) were tested using the highest configuration antenna (85009260001) and battery (SNN5793A). The highest SAR result from the table below is provided in APPENDIX F Section 9.0 - 806-825MHz Band Assessment of frequency band edges of the offered antenna.

**TABLE 21**

806-825MHz Band Assessments at REAR (1:3 phone mode) -Assessment of frequency band edges of the offered antenna												
Run Number/ SN	Antenna	Freq. (MHz)	Battery	Test position	Carry Case	Additional attachments	Initial Power (W)	SAR Drift (dB)	Meas. 1g-SAR (W/kg)	Meas. 10g-SAR (W/kg)	Max Calc. 1g-SAR (W/kg)	Max Calc. 10g-SAR (W/kg)
CM-Rear-091204-21 / 364VKUTFS8	85009260001 (internal)	806.012 5	SNN5793A w/ NTN2566xxx A	Cheek Touch	None	None	0.632	-0.071	0.967	0.695	1.00	0.72
CM-Rear-091204-22 / 364VKUTFS8	85009260001 (internal)	824.987 5	SNN5793A w/ NTN2566xxx A	Cheek Touch	None	None	0.635	-0.049	1.160	0.835	1.18	0.85

**Assessments at the Face (1:6 Dispatch mode)**

**Assessment of the offered antenna (Test Flowchart pg 20 step 1);** Antenna search is not required because only one antenna is offered for 806-825MHz bands. Move to step 2.

**Assessment of the offered batteries (Test Flowchart pg 20 step 2);** The highest battery from the left ear was used for face testing and therefore a battery search is not required. Move to step 3.

**Assessment of frequency band of the offered antenna (Test Flowchart pg 20 step 3);** The frequency band (low, mid and high) was tested using the highest configuration antenna (85009260001) and battery (SNN5793A) and with the DUT positioned at 2.5cm from the phantom. The highest SAR result from the table below is provided in APPENDIX F Section 10.0 - 806-825MHz Band Assessment of frequency band of the offered antenna.

**TABLE 22**

806-825MHz Band Assessments at Face (1:6 dispatch mode) – Assessment of frequency band edges of the offered antenna												
Run Number/ SN	Antenna	Freq. (MHz)	Battery	Test position	Carry Case	Additional attachments	Initial Power (W)	SAR Drift (dB)	Meas. 1g-SAR (W/kg)	Meas. 10g-SAR (W/kg)	Max Calc. 1g-SAR (W/kg)	Max Calc. 10g-SAR (W/kg)
HvH-Face-091205-06 / 364VKUTFSS8	85009260001 (internal)	806.012 5	SNN5793A w/ NTN2566xxx A	Front 2.5cm	None	None	0.636	0.0456	0.22	0.16	0.11	0.08
HvH-Face-091205-07 / 364VKUTFSS8	85009260001 (internal)	815.512 5	SNN5793A w/ NTN2566xxx A	Front 2.5cm	None	None	0.626	-0.026	0.229	0.162	0.12	0.08
HvH-Face-091205-08 / 364VKUTFSS8	85009260001 (internal)	824.987 5	SNN5793A w/ NTN2566xxx A	Front 2.5cm	None	None	0.64	-0.11	0.239	0.171	0.12	0.09

### 13.3 Test Flowchart Data Summary 896-902MHz Band

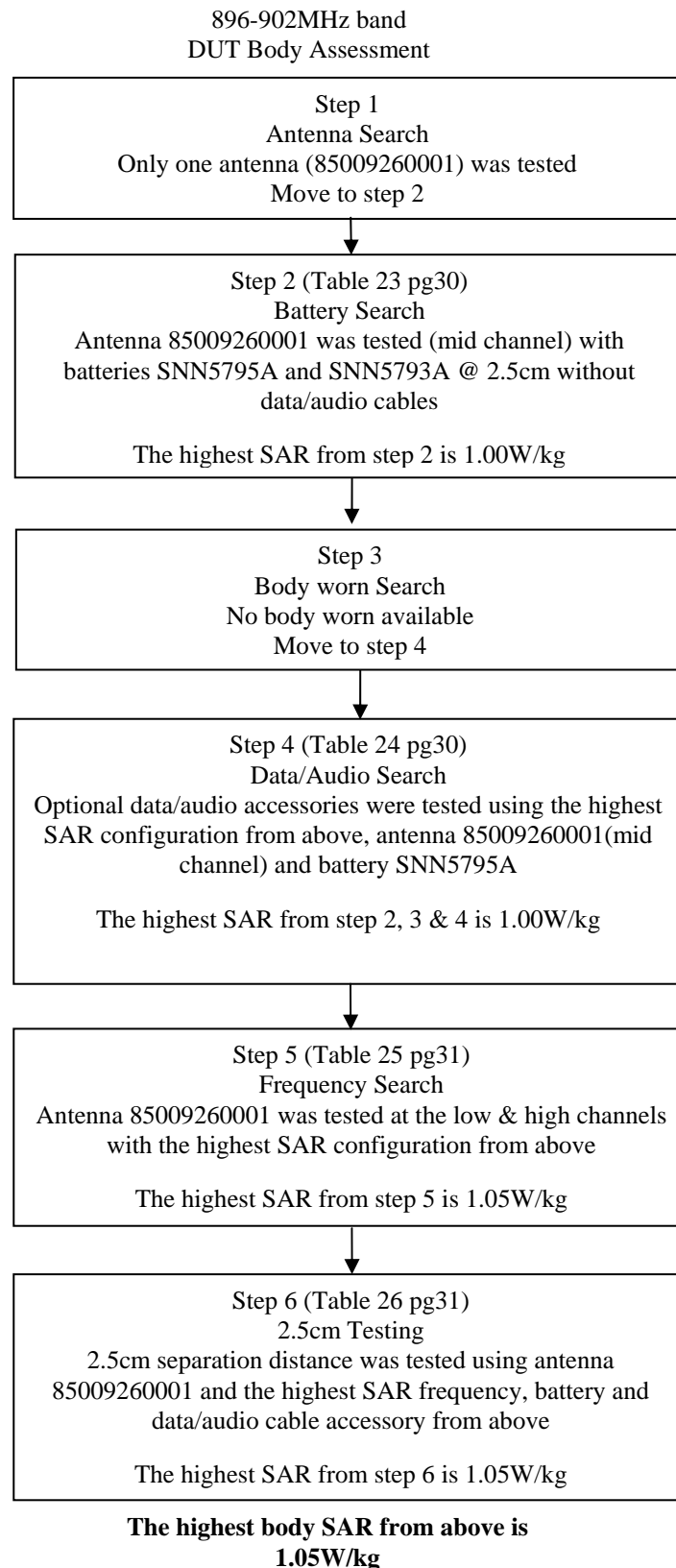

896-902MHz band  
DUT Head Left Ear Assessment

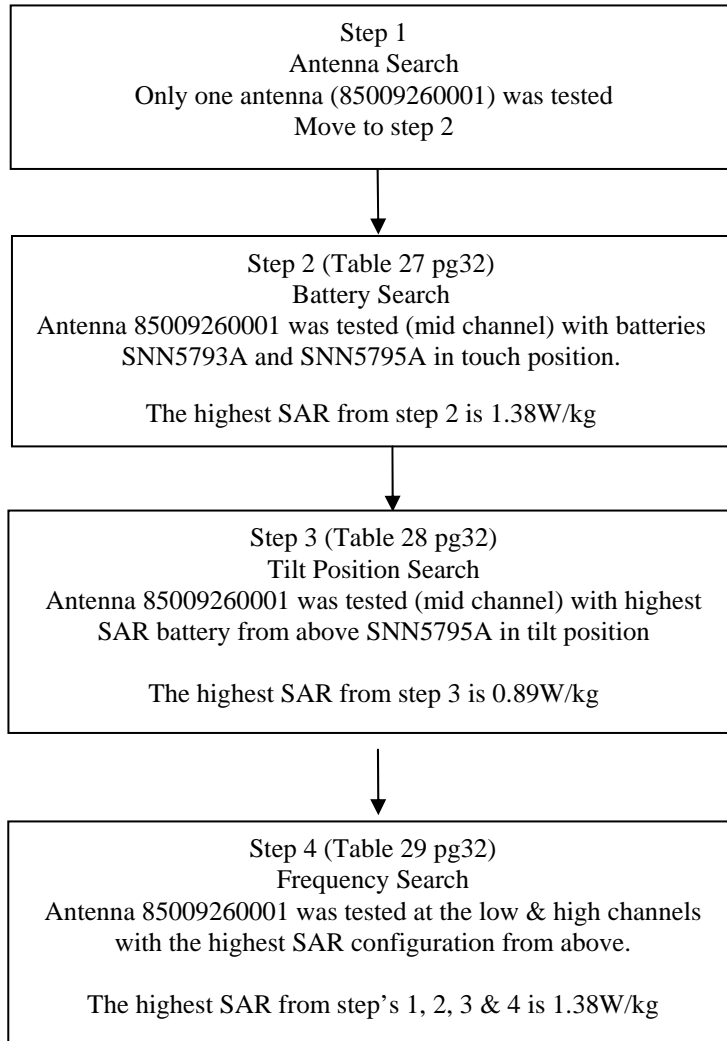

**The highest Head Left Ear SAR from above  
is 1.38W/kg**

896-902MHz band  
DUT Head Right Ear Assessment

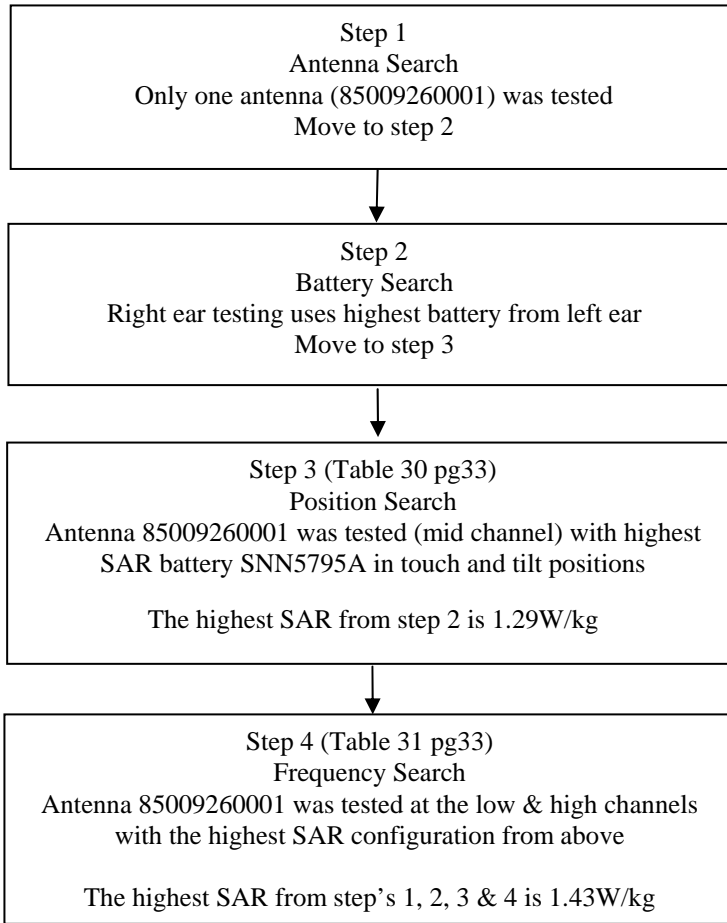

**The highest Head SAR – Right Ear from above is 1.43W/kg**

896-902MHz band  
DUT Face Assessment

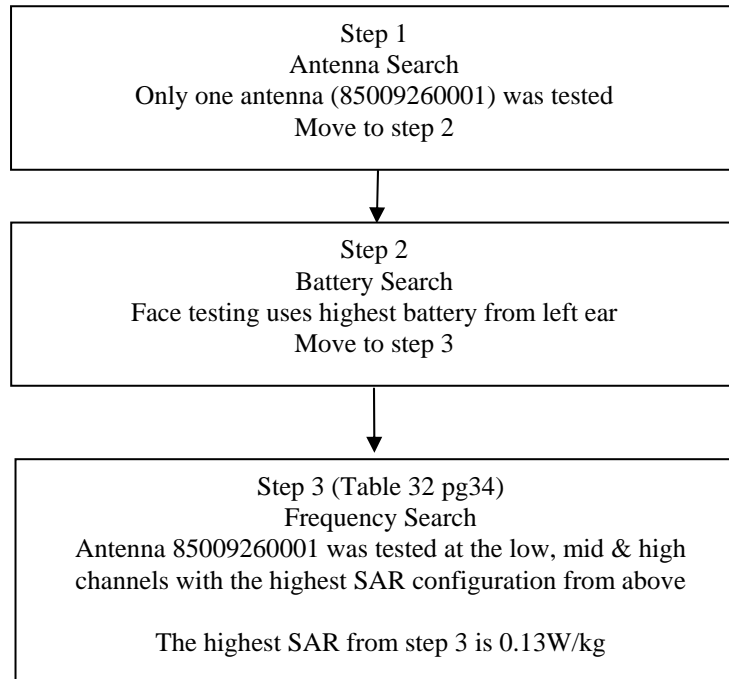

**The highest Face SAR from above is  
0.13W/kg**

**13.4 896-902MHz Band Test Data**

**Assessments at the Body (236:310 data mode)**

**Assessment of the offered antenna (Test Flowchart pg 26 step 1);** Antenna search is not required because only one antenna is offered for 896-902MHz bands. Move to step 2.

**Assessment of the offered batteries (Test Flowchart pg 26 step 2);** The optional batteries were tested. These tests were conducted at mid channel using antenna (85009260001) with DUT positioned 2.5cm from phantom and without a data cable. The highest SAR result from the table below is provided in APPENDIX F Section 11.0 – 896-902MHz Band Assessment of the offered batteries.

**TABLE 23**

896-902MHz Band Assessments at Body (236:310 data mode) – Assessment of offered batteries												
Run Number/ SN	Antenna	Freq. (MHz)	Battery	Test position	Carry Case	Additional attachments	Initial Power (W)	SAR Drift (dB)	Meas. 1g-SAR (W/kg)	Meas. 10g-SAR (W/kg)	Max Calc. 1g-SAR (W/kg)	Max Calc. 10g-SAR (W/kg)
JsT-Ab-091211-08 / 364VKUTFS8	85009260001 (internal)	898.9937 5	SNN5795A w/ NTN2565xxxA	DUT back 2.5cm	None	None	0.626	-0.424	0.878	0.631	1.00	0.72
JsT-Ab-091211-09 / 364VKUTFS8	85009260001 (internal)	898.9937 5	SNN5793A w/ NTN2566xxxA	DUT back 2.5cm	None	None	0.625	-0.392	0.722	0.523	0.82	0.59

**Assessment of the offered body worn accessory (Test Flowchart pg 26 step 3);** Body worn accessory search is not required because no body worn is offered. Move to step 4.

**Assessment of the offered data/audio cable accessories (Test Flowchart pg 26 step 4);** The optional data/audio cable were tested in their applicable modes (236:310, 1:3) at mid channel using highest configuration antenna (85009260001), battery (SNN5795A) with DUT positioned 2.5cm from phantom. The highest SAR result from the table below is provided in APPENDIX F Section 12.0 - 896-902MHz Band Assessment of the offered data/audio cables.

**TABLE 24**

896-902MHz Band Assessments at Body (236:310 data mode) – Assessment of offered data cable												
Run Number/ SN	Antenna	Freq. (MHz)	Battery	Test position	Carry Case	Additional attachments	Initial Power (W)	SAR Drift (dB)	Meas. 1g-SAR (W/kg)	Meas. 10g-SAR (W/kg)	Max Calc. 1g-SAR (W/kg)	Max Calc. 10g-SAR (W/kg)
JsT-Ab-091211-10 / 364VKUTFS8	85009260001 (internal)	898.9937 5	SNN5795A w/ NTN2565xxxA	DUT back 2.5cm	None	SKN6238A (USB Cable)	0.625	-0.675	0.648	0.474	0.79	0.58
896-902MHz Band Assessments at Body (1:3 phone mode) – Assessment of offered audio accessory												
MeC-Ab-091211-11 / 364VKUTFS8	85009260001 (internal)	898.9937 5	SNN5795A w/ NTN2565xxxA	DUT back 2.5cm	None	NNTN5330B PTT Headset, Earbud	0.627	-0.444	0.394	0.284	0.45	0.32
MeC-Ab-091211-12 / 364VKUTFS8	85009260001 (internal)	898.9937 5	SNN5795A w/ NTN2565xxxA	DUT back 2.5cm	None	NNTN5211B 2-wire Surveillance Headset	0.626	-0.443	0.419	0.300	0.47	0.34
MeC-Ab-091211-13 / 364VKUTFS8	85009260001 (internal)	898.9937 5	SNN5795A w/ NTN2565xxxA	DUT back 2.5cm	None	NNTN6312A 3-wire Surveillance Headset	0.626	-0.323	0.405	0.294	0.45	0.32

**Assessments at the Body (236:310 data mode)**

**Assessment of frequency band edges of the offered antenna (Test Flowchart pg 26 step 5);** The frequency band edges (low and high) were tested using the highest configuration antenna (85009260001), battery (SNN5795A), with DUT positioned 2.5cm from phantom without a data cable. The highest SAR result from the table below is provided in APPENDIX F Section 13.0 - 896-902MHz Band Assessment of frequency band edges of the offered antenna.

**TABLE 25**

896-902MHz Band Assessments at Body (236:310 data mode) -Assessment of frequency band edges of the offered antenna												
Run Number/ SN	Antenna	Freq. (MHz)	Battery	Test position	Carry Case	Additional attachments	Initial Power (W)	SAR Drift (dB)	Meas. 1g-SAR (W/kg)	Meas. 10g-SAR (W/kg)	Max Calc. 1g-SAR (W/kg)	Max Calc. 10g-SAR (W/kg)
MeC-Ab-091211-14 / 364VKUTFS8	85009260001 (internal)	896.018 75	SNN5795A w/ NTN2565xxx A	DUT back 2.5cm	None	None	0.631	-0.318	0.946	0.683	1.05	0.76
MeC-Ab-091211-15 / 364VKUTFS8	85009260001 (internal)	901.981 25	SNN5795A w/ NTN2565xxx A	DUT back 2.5cm	None	None	0.634	-0.386	0.910	0.643	1.02	0.72

**Assessment without body worn accessory at 2.5cm (Test Flowchart pg 26 step 6);** The highest SAR test configuration (antenna 85009260001, frequency 896.01875MHz, battery SNN5795A and without data cable) was selected to assess this device at 2.5cm with the front and back of the device facing the phantom. The highest SAR result from the table below is provided in APPENDIX F Section 14.0 - 896-902MHz Band Assessment without body worn accessory at 2.5cm.

Note: The 2.5cm assessments included the following configurations:

- Back of the device facing the phantom, positioned at 2.5cm from the phantom surface.
- Front of the device facing the phantom, positioned at 2.5cm from the phantom surface.

**TABLE 26**

896-902MHz Band Assessments at Body (236:310 data mode) - Assessment at 2.5cm												
Run Number/ SN	Antenna	Freq. (MHz)	Battery	Test position	Carry Case	Additional attachments	Initial Power (W)	SAR Drift (dB)	Meas. 1g-SAR (W/kg)	Meas. 10g-SAR (W/kg)	Max Calc. 1g-SAR (W/kg)	Max Calc. 10g-SAR (W/kg)
MeC-Ab-091211-14 / 364VKUTFS8	85009260001 (internal)	896.018 75	SNN5795A w/ NTN2565xxx A	DUT back 2.5cm	None	None	0.631	-0.318	0.946	0.683	1.05	0.76
MeC-Ab-091211-16 / 364VKUTFS8	85009260001 (internal)	896.018 75	SNN5795A w/ NTN2565xxx A	DUT front 2.5cm	None	None	0.633	-0.320	0.919	0.650	1.01	0.72

**Assessments at the Head Left Ear (1:3 Phone mode)**

**Assessment of the offered antenna (Test Flowchart pg 27 step 1);** Antenna search is not required because only one antenna is offered for 896-902MHz bands. Move to step 2.

**Assessment of the offered batteries (Test Flowchart pg 27 step 2);** The optional batteries were tested. These tests were conducted at mid channel using antenna (85009260001) at the left ear touch position. The highest SAR result from the table below is provided in APPENDIX F Section 15.0 – 896-902MHz Band Assessment of the offered batteries.

**TABLE 27**

896-902MHz Band Assessments at LEAR (1:3 phone mode) – Assessment of offered batteries												
Run Number/ SN	Antenna	Freq. (MHz)	Battery	Test position	Carry Case	Additional attachments	Initial Power (W)	SAR Drift (dB)	Meas. 1g-SAR (W/kg)	Meas. 10g-SAR (W/kg)	Max Calc. 1g-SAR (W/kg)	Max Calc. 10g-SAR (W/kg)
JsT-Lear-091204-14 / 364VKUTFS8	85009260001 (internal)	898.993 75	SNN5795A w/ NTN2565xxx A	Cheek Touch	None	None	0.628	-0.380	1.240	0.866	1.38	0.96
JsT-Lear-091204-15 / 364VKUTFS8	85009260001 (internal)	898.993 75	SNN5793A w/ NTN2566xxx A	Cheek Touch	None	None	0.627	-0.090	1.300	0.903	1.35	0.94

**Assessment of the Position (Test Flowchart pg 27 step 3);** The tilt position was tested at mid channel using highest configuration antenna (85009260001) and battery (SNN5795A). The highest SAR result from the table below is provided in APPENDIX F Section 16.0 – 896-902MHz Band Assessment of the tilt position.

**TABLE 28**

896-902MHz Band Assessments at LEAR (1:3 phone mode) – Assessment of tilt position												
Run Number/ SN	Antenna	Freq. (MHz)	Battery	Test position	Carry Case	Additional attachments	Initial Power (W)	SAR Drift (dB)	Meas. 1g-SAR (W/kg)	Meas. 10g-SAR (W/kg)	Max Calc. 1g-SAR (W/kg)	Max Calc. 10g-SAR (W/kg)
JsT-Lear-091204-16 / 364VKUTFS8	85009260001 (internal)	898.993 75	SNN5795A w/ NTN2565xxx A	15° Tilt	None	None	0.627	-0.124	0.849	0.597	0.89	0.63

**Assessment of frequency band edges of the offered antenna (Test Flowchart pg 27 step 4);** The frequency band edges (low and high) were tested using the highest configuration antenna (85009260001) and battery (SNN5795A). The highest SAR result from the table below is provided in APPENDIX F Section 17.0 - 896-902MHz Band Assessment of frequency band edges of the offered antenna.

**TABLE 29**

896-902MHz Band Assessments at LEAR (1:3 phone mode) -Assessment of frequency band edges of the offered antenna												
Run Number/ SN	Antenna	Freq. (MHz)	Battery	Test position	Carry Case	Additional attachments	Initial Power (W)	SAR Drift (dB)	Meas. 1g-SAR (W/kg)	Meas. 10g-SAR (W/kg)	Max Calc. 1g-SAR (W/kg)	Max Calc. 10g-SAR (W/kg)
CM-Lear-091204-17 / 364VKUTFS8	85009260001 (internal)	896.018 75	SNN5795A w/ NTN2565xxx A	Cheek Touch	None	None	0.630	-0.248	1.236	0.863	1.33	0.93
CM-Lear-091204-18 / 364VKUTFS8	85009260001 (internal)	901.981 25	SNN5795A w/ NTN2565xxx A	Cheek Touch	None	None	0.620	-0.283	1.220	0.856	1.34	0.94

**Assessments at the Head Right Ear (1:3 Phone mode)**

**Assessment of the offered antenna (Test Flowchart pg 28 step 1);** Antenna search is not required because only one antenna is offered for 896-902MHz bands. Move to step 2.

**Assessment of the offered batteries (Test Flowchart pg 28 step 2);** The highest battery from the left ear was used for right ear testing and therefore a battery search is not required. Move to step 3.

**Assessment of the positions (Test Flowchart pg 28 step 3);** The touch and tilt positions were tested using the highest battery (SNN5795A) from the left ear. These tests were conducted at mid channel using antenna (85009260001). The highest SAR result from the table below is provided in APPENDIX F Section 18.0 – 896-902MHz Band Assessment of the touch and tilt positions.

**TABLE 30**

896-902MHz Band Assessments at REAR (1:3 phone mode) – Assessment of touch and tilt position												
Run Number/ SN	Antenna	Freq. (MHz)	Battery	Test position	Carry Case	Additional attachments	Initial Power (W)	SAR Drift (dB)	Meas. 1g-SAR (W/kg)	Meas. 10g-SAR (W/kg)	Max Calc. 1g-SAR (W/kg)	Max Calc. 10g-SAR (W/kg)
HvH-Rear- 091205-02 / 364VKUTF8	85009260001 (internal)	898.993 75	SNN5795A w/ NTN2565xxx A	Cheek Touch	None	None	0.628	-0.204	1.210	0.850	1.29	0.91
HvH-Rear-091205- 03 / 364VKUTF8	85009260001 (internal)	898.993 75	SNN5795A w/ NTN2565xxx A	15° Tilt	None	None	0.628	-0.110	0.847	0.601	0.89	0.63

**Assessment of frequency band edges of the offered antenna (Test Flowchart pg 28 step 4);** The frequency band edges (low and high) were tested using the highest configuration antenna (85009260001) and battery (SNN5795A). The highest SAR result from the table below is provided in APPENDIX F Section 19.0 - 896-902MHz Band Assessment of frequency band edges of the offered antenna.

**TABLE 31**

896-902MHz Band Assessments at REAR (1:3 phone mode) -Assessment of frequency band edges of the offered antenna												
Run Number/ SN	Antenna	Freq. (MHz)	Battery	Test position	Carry Case	Additional attachments	Initial Power (W)	SAR Drift (dB)	Meas. 1g-SAR (W/kg)	Meas. 10g-SAR (W/kg)	Max Calc. 1g-SAR (W/kg)	Max Calc. 10g-SAR (W/kg)
HvH-Rear- 091205-04 / 364VKUTF8	85009260001 (internal)	896.018 75	SNN5795A w/ NTN2565xxx A	Cheek Touch	None	None	0.629	-0.264	1.320	0.921	1.43	1.00
HvH-Rear-091205- 05 / 364VKUTF8	85009260001 (internal)	901.981 25	SNN5795A w/ NTN2565xxx A	Cheek Touch	None	None	0.622	-0.254	1.280	0.887	1.40	0.97

**Assessments at the Face (1:6 Dispatch mode)**

**Assessment of the offered antenna (Test Flowchart pg 29 step 1);** Antenna search is not required because only one antenna is offered for 896-902MHz bands. Move to step 2.

**Assessment of the offered batteries (Test Flowchart pg 29 step 2);** The highest battery from the left ear was used for face testing and therefore a battery search is not required. Move to step3.

**Assessment of frequency band of the offered antenna (Test Flowchart pg 29 step 3);** The frequency band edges (low, mid and high) were tested using the highest configuration antenna (85009260001) and battery (SNN5795A) and with the DUT positioned at 2.5cm from the phantom. The highest SAR result from the table below is provided in APPENDIX F Section 20.0 - 896-902MHz Band Assessment of frequency band edges of the offered antenna.

**TABLE 32**

896-902MHz Band Assessments at Face (1:6 dispatch mode) – Assessment of frequency band edges of the offered antenna												
Run Number/ SN	Antenna	Freq. (MHz)	Battery	Test position	Carry Case	Additional attachments	Initial Power (W)	SAR Drift (dB)	Meas. 1g-SAR (W/kg)	Meas. 10g-SAR (W/kg)	Max Calc. 1g-SAR (W/kg)	Max Calc. 10g-SAR (W/kg)
HvH-Face-091205-09 / 364VKUTFS8	85009260001 (internal)	896.018 75	SNN5795A w/ NTN2565xxx A	Front 2.5cm	None	None	0.634	-0.101	0.245	0.178	0.13	0.09
<b>HvH-Face-091205-10 / 364VKUTFS8</b>	85009260001 (internal)	898.993 75	SNN5795A w/ NTN2565xxx A	Front 2.5cm	None	None	0.629	0.011	0.246	0.174	0.13	0.09
HvH-Face-091205-11 / 364VKUTFS8	85009260001 (internal)	901.981 25	SNN5795A w/ NTN2565xxx A	Front 2.5cm	None	None	0.625	-0.025	0.235	0.168	0.12	0.09

**13.5 MOTotalk Test Flowchart Data Summary 902-928MHz Band**

MOTotalk Band (902-928MHz)  
DUT Body Test Methodology

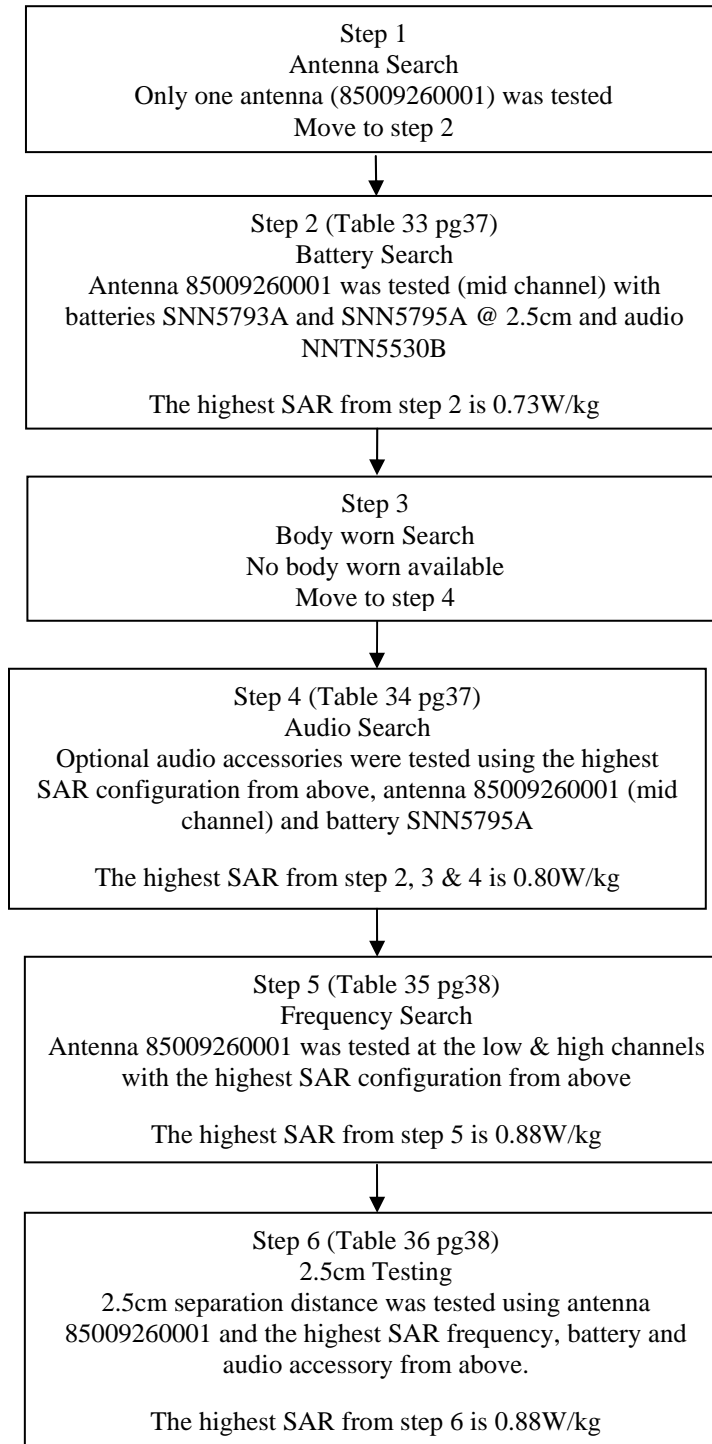

**The highest MOTotalk body SAR from above is 0.88W/kg**

MOTotalk Band (902-928MHz)  
DUT Face Test Methodology

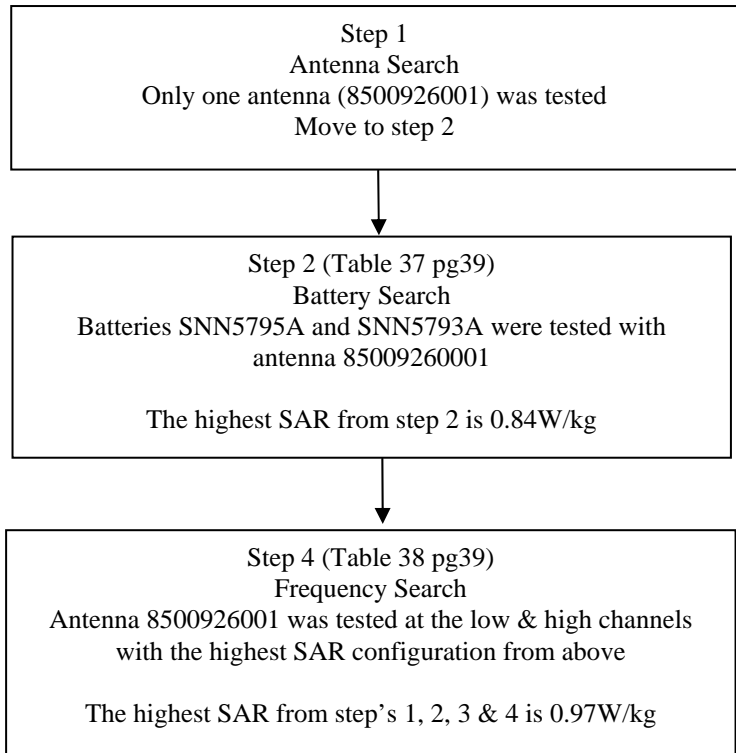

**The highest MOTotalk Face SAR from above is 0.97W/kg**

**13.6 MOTotalk Test Data**

**Assessments at the Body (114:120 mode)**

**Assessment of the offered antenna (MOTotalk Test Flowchart pg 35 step 1);** Antenna search is not required because only one antenna is offered for 902-928MHz bands. Move to step 2.

**Assessment of the offered batteries (MOTotalk Test Flowchart pg 35 step 2);** The optional batteries were tested. These tests were conducted at mid channel using antenna (85009260001), with DUT positioned 2.5cm from phantom and audio cable (NNTN5330B). The highest SAR result from the table below is provided in APPENDIX F Section 21.0 - MOTotalk Assessment of the offered batteries.

**TABLE 33**

902-928MHz Band Assessments at Body (114:120 mode) – Assessment of offered batteries												
Run Number/ SN	Antenna	Freq. (MHz)	Battery	Test position	Carry Case	Additional attachments	Initial Power (W)	SAR Drift (dB)	Meas. 1g-SAR (W/kg)	Meas. 10g-SAR (W/kg)	Max Calc. 1g-SAR (W/kg)	Max Calc. 10g-SAR (W/kg)
HvH-Ab-091214-02 / 364VKUTFS8	85009260001 (internal)	915.525	SNN5795A w/ NTN2565xxx A	DUT back 2.5cm	None	NNTN5330B PTT Headset, Earbud	0.845	0.019	1.380	0.990	0.73	0.52
HvH-Ab-091214-03 / 364VKUTFS8	85009260001 (internal)	915.525	SNN5793A w/ NTN2566xxx A	DUT back 2.5cm	None	NNTN5330B PTT Headset, Earbud	0.847	-0.017	0.995	0.714	0.53	0.38

**Assessment of the offered body worn accessory (MOTotalk Test Flowchart pg 35 step 3);** Body worn accessory search is not required because no body worn is offered. Move to step 4.

**Assessment of the offered audio accessory (MOTotalk Test Flowchart pg 35 step 4);** The optional audio cable accessories were tested at mid channel using the highest configuration antenna (85009260001), battery (SNN5795A) with DUT positioned 2.5cm from phantom. The highest SAR result from the table below is provided in APPENDIX F Section 22.0 - MOTotalk Assessment of the offered audio accessory.

**TABLE 34**

902-928MHz Band Assessments at Body (114:120 mode) – Assessment of offered audio accessory												
Run Number/ SN	Antenna	Freq. (MHz)	Battery	Test position	Carry Case	Additional attachments	Initial Power (W)	SAR Drift (dB)	Meas. 1g-SAR (W/kg)	Meas. 10g-SAR (W/kg)	Max Calc. 1g-SAR (W/kg)	Max Calc. 10g-SAR (W/kg)
HvH-Ab-091214-04 / 364VKUTFS8	85009260001 (internal)	915.525	SNN5795A w/ NTN2565xxx A	DUT back 2.5cm	None	NNTN5211B 2-wire Surveillance Headset	0.846	-0.096	1.480	1.060	0.80	0.57
HvH-Ab-091214-05 / 364VKUTFS8	85009260001 (internal)	915.525	SNN5795A w/ NTN2565xxx A	DUT back 2.5cm	None	NNTN6312A 3-wire Surveillance Headset	0.846	-0.043	1.420	1.010	0.76	0.54

**Assessments at the Body (114:120 mode)**

**Assessment of frequency band edges of the offered antenna (MOTOtalk Test Flowchart pg 35 step 5);** The frequency band edges (low and high) were tested using the highest configuration antenna (85009260001), battery (SNN5795A), with DUT positioned 2.5cm from phantom and audio (NNTN5211B). The highest SAR result from the table below is provided in APPENDIX F Section 23.0 - MOTOtalk Assessment of frequency band edges of the offered antenna.

**TABLE 35**

902-928MHz Band Assessments at Body (114:120 mode) -Assessment of frequency band edges of the offered antenna												
Run Number/ SN	Antenna	Freq. (MHz)	Battery	Test position	Carry Case	Additional attachments	Initial Power (W)	SAR Drift (dB)	Meas. 1g-SAR (W/kg)	Meas. 10g-SAR (W/kg)	Max Calc. 1g-SAR (W/kg)	Max Calc. 10g-SAR (W/kg)
HvH-Ab-091214-06 / 364VKUTFS8	85009260001 (internal)	902.525	SNN5795A w/ NTN2565xxx A	DUT back 2.5cm	None	NNTN5211B 2-wire Surveillance Headset	0.845	-0.004	1.660	1.190	0.88	0.63
HvH-Ab-091214-07 / 364VKUTFS8	85009260001 (internal)	927.475	SNN5795A w/ NTN2565xxx A	DUT back 2.5cm	None	NNTN5211B 2-wire Surveillance Headset	0.855	-0.002	1.320	0.940	0.69	0.49

**Assessment without body worn accessory at 2.5cm (MOTOtalk Test Flowchart pg 35 step 6);** The highest SAR test configuration (antenna 85009260001, frequency 902.525MHz, battery SNN5795A and audio NNTN5211B) was selected to assess this device at 2.5cm with the front and back of the device facing the phantom. The highest SAR result from the table below is provided in APPENDIX F Section 24.0 - MOTOtalk Assessment without body worn accessory at 2.5cm.

Note: The 2.5cm assessments included the following configurations:

- Back of the device facing the phantom, positioned at 2.5cm from the phantom surface.
- Front of the device facing the phantom, positioned at 2.5cm from the phantom surface.

**TABLE 36**

902-928MHz Band Assessments at Body (114:120 mode) - Assessment at 2.5cm												
Run Number/ SN	Antenna	Freq. (MHz)	Battery	Test position	Carry Case	Additional attachments	Initial Power (W)	SAR Drift (dB)	Meas. 1g-SAR (W/kg)	Meas. 10g-SAR (W/kg)	Max Calc. 1g-SAR (W/kg)	Max Calc. 10g-SAR (W/kg)
HvH-Ab-091214-06 / 364VKUTFS8	85009260001 (internal)	902.525	SNN5795A w/ NTN2565xxx A	DUT back 2.5cm	None	NNTN5211B 2-wire Surveillance Headset	0.845	-0.004	1.660	1.190	0.88	0.63
HvH-Ab-091214-08 / 364VKUTFS8	85009260001 (internal)	902.525	SNN5795A w/ NTN2565xxx A	DUT front 2.5cm	None	NNTN5211B 2-wire Surveillance Headset	0.848	0.019	1.570	1.130	0.82	0.59

**Assessments at the Face (114:120 mode)**

**Assessment of the offered antenna (MOTOtalk Test Flowchart pg 36 step 1);** Antenna search is not required because only one antenna is offered for 902-928MHz bands. Move to step 2.

**Assessment of the offered battery (MOTOtalk Test Flowchart pg 36 step 2);** The optional batteries were tested. These tests were conducted at mid channel using antenna (85009260001) with the front of the radio positioned at 2.5cm from the phantom. The highest SAR result from the table below is provided in APPENDIX F Section 25.0 - MOTOtalk Assessment of the offered battery.

**TABLE 37**

902-928MHz Band Assessments at Face (114:120 mode) – Assessment of offered battery												
Run Number/ SN	Antenna	Freq. (MHz)	Battery	Test position	Carry Case	Additional attachments	Initial Power (W)	SAR Drift (dB)	Meas. 1g-SAR (W/kg)	Meas. 10g-SAR (W/kg)	Max Calc. 1g-SAR (W/kg)	Max Calc. 10g-SAR (W/kg)
HvH-Face-091205-13 / 364VKUTFS8	85009260001 (internal)	915.525	SNN5795A w/ NTN2565xxx A	Front 2.5cm	None	None	0.829	-0.074	1.530	1.009	0.84	0.60
HvH-Face-091205-15 / 364VKUTFS8	85009260001 (internal)	915.525	SNN5793A w/ NTN2566xxx A	Front 2.5cm	None	None	0.835	-0.008	1.470	1.040	0.79	0.56

**Assessment of frequency band edges of the offered antenna (MOTOtalk Test Flowchart pg 36 step 3);** The frequency band edges (low and high) were tested using the highest configuration, antenna (85009260001), battery (SNN5795A). The highest SAR result from the table below is provided in APPENDIX F Section 26.0 - MOTOtalk Assessment of frequency band edges of the offered antenna.

**TABLE 38**

902-928MHz Band Assessments at Face (114:120 mode) – Assessment of frequency band edges of the offered antenna												
Run Number/ SN	Antenna	Freq. (MHz)	Battery	Test position	Carry Case	Additional attachments	Initial Power (W)	SAR Drift (dB)	Meas. 1g-SAR (W/kg)	Meas. 10g-SAR (W/kg)	Max Calc. 1g-SAR (W/kg)	Max Calc. 10g-SAR (W/kg)
HvH-Face-091205-16 / 364VKUTFS8	85009260001 (internal)	902.525	SNN5795A w/ NTN2565xxx A	Front 2.5cm	None	None	0.839	-0.055	1.810	1.290	0.97	0.69
HvH-Face-091205-17 / 364VKUTFS8	85009260001 (internal)	927.475	SNN5795A w/ NTN2565xxx A	Front 2.5cm	None	None	0.847	-0.021	1.380	0.978	0.73	0.52

### 13.7 Shorten Scan Assessment

**Short scan assessment of the overall SAR highest configuration (896-902MHz Band Assessment TABLE 31 pg33);** A “shortened” scan was performed, using the test configuration and unit that produced the highest SAR results overall (in bold with \*) below, to validate the SAR drift of the full DASY4™ coarse and 5x5x7 zoom scans. Note that the shortened scan represents the zoom scan performance result; this is obtained by first running a coarse scan to find the peak area and then, using a newly charged battery, a 5x5x7 zoom scan only was performed. The results of the shortened cube scan presented in APPENDIX E demonstrate that the scaling methodology used to determine the calculated SAR results presented herein are valid. The highest SAR result from the table below is provided in APPENDIX E – Shortened Scan Results.

**TABLE 39**

Shorten Scan Assessment at the Head – 1:3 phone mode												
Run Number/ SN	Antenna	Freq. (MHz)	Battery	Test position	Carry Case	Additional attachments	Initial Power (W)	SAR Drift (dB)	Meas. 1g-SAR (W/kg)	Meas. 10g-SAR (W/kg)	Max Calc. 1g-SAR (W/kg)	Max Calc. 10g-SAR (W/kg)
<b>*HvH-Rear-091205-04 / 364VKUTFS8</b>	85009260001 (internal)	896.018 75	SNN5795A w/ NTN2565xxx A	Cheek Touch	None	None	0.629	-0.264	1.320	0.921	1.43	1.00
<b>Shorten scan JsT-Rear-100108-02 / 364VKUTFS8</b>	85009260001 (internal)	896.018 75	SNN5795A w/ NTN2565xxx A	Cheek Touch	None	None	0.637	-0.130	1.350	0.949	1.40	0.982

### 14.0 Conclusion

The highest Operational Maximum Calculated 1-gram and 10-gram average SAR values found for FCC ID: IHDP56KY1 model H88XAH6JR2AN.

**Max. Calc. : 1-g Avg. SAR: 1.09 W/kg (Body); 10-g Avg. SAR: 0.79 W/kg (Body)**  
**Max. Calc. : 1-g Avg. SAR: 1.43 W/kg (Head); 10-g Avg. SAR: 1.00 W/kg (Head)**  
**Max. Calc. : 1-g Avg. SAR: 0.97 W/kg (Face); 10-g Avg. SAR: 0.69 W/kg (Face)**

The test results clearly demonstrate compliance with FCC General Population/Uncontrolled RF Exposure limits of **1.6 W/kg** per the requirements of 47 CFR 2.1093(d).

## **APPENDIX A**

### **Measurement Uncertainty**

The Measurement Uncertainty tables indicated in this APPENDIX are applicable to the DUT ranging from 800MHz to 3GHz, and for Dipole test frequency ranging from 800MHz to 3GHz. Therefore, the highest tolerance for the probe calibration uncertainty is indicated.

**Table 1A: Uncertainty Budget for Device Under Test, for 800MHz to 3GHz**

<i>a</i>	<i>b</i>	<i>c</i>	<i>d</i>	<i>e = f(d,k)</i>	<i>f</i>	<i>g</i>	<i>h = c x f / e</i>	<i>i = c x g / e</i>	<i>k</i>
Uncertainty Component	IEEE 1528 section	Tol. (± %)	Prob Dist	Div.	<i>c<sub>i</sub></i> (1 g)	<i>c<sub>i</sub></i> (10 g)	1 g <i>u<sub>i</sub></i> (±%)	10 g <i>u<sub>i</sub></i> (±%)	<i>v<sub>i</sub></i>
<b>Measurement System</b>									
Probe Calibration	E.2.1	5.9	N	1.00	1	1	5.9	5.9	∞
Axial Isotropy	E.2.2	4.7	R	1.73	0.707	0.707	1.9	1.9	∞
Hemispherical Isotropy	E.2.2	9.6	R	1.73	0.707	0.707	3.9	3.9	∞
Boundary Effect	E.2.3	1.0	R	1.73	1	1	0.6	0.6	∞
Linearity	E.2.4	4.7	R	1.73	1	1	2.7	2.7	∞
System Detection Limits	E.2.5	1.0	R	1.73	1	1	0.6	0.6	∞
Readout Electronics	E.2.6	0.3	N	1.00	1	1	0.3	0.3	∞
Response Time	E.2.7	1.1	R	1.73	1	1	0.6	0.6	∞
Integration Time	E.2.8	1.1	R	1.73	1	1	0.6	0.6	∞
RF Ambient Conditions - Noise	E.6.1	3.0	R	1.73	1	1	1.7	1.7	∞
RF Ambient Conditions - Reflections	E.6.1	0.0	R	1.73	1	1	0.0	0.0	∞
Probe Positioner Mech. Tolerance	E.6.2	0.4	R	1.73	1	1	0.2	0.2	∞
Probe Positioning w.r.t Phantom	E.6.3	1.4	R	1.73	1	1	0.8	0.8	∞
Max. SAR Evaluation (ext., int., avg.)	E.5	3.4	R	1.73	1	1	2.0	2.0	∞
<b>Test sample Related</b>									
Test Sample Positioning	E.4.2	3.2	N	1.00	1	1	3.2	3.2	29
Device Holder Uncertainty	E.4.1	4.0	N	1.00	1	1	4.0	4.0	8
SAR drift	6.6.2	5.0	R	1.73	1	1	2.9	2.9	∞
<b>Phantom and Tissue Parameters</b>									
Phantom Uncertainty	E.3.1	4.0	R	1.73	1	1	2.3	2.3	∞
Liquid Conductivity (target)	E.3.2	5.0	R	1.73	0.64	0.43	1.8	1.2	∞
Liquid Conductivity (measurement)	E.3.3	3.3	N	1.00	0.64	0.43	2.1	1.4	∞
Liquid Permittivity (target)	E.3.2	5.0	R	1.73	0.6	0.49	1.7	1.4	∞
Liquid Permittivity (measurement)	E.3.3	1.9	N	1.00	0.6	0.49	1.1	0.9	∞
<b>Combined Standard Uncertainty</b>			RSS				11	11	411
<b>Expanded Uncertainty (95% CONFIDENCE LEVEL)</b>			<i>k</i> =2				22	22	

**Table 2A: Uncertainty Budget for System Validation (dipole & flat phantom) for 800MHz to 3GHz**

<i>a</i>	<i>b</i>	<i>c</i>	<i>d</i>	$e = f(d,k)$	<i>f</i>	<i>g</i>	$h = c \times f / e$	$i = c \times g / e$	<i>k</i>
Uncertainty Component	IEEE 1528 section	Tol. ( $\pm \%$ )	Prob. Dist.	Div.	$c_i$ (1 g)	$c_i$ (10 g)	1 g $u_i$ ( $\pm\%$ )	10 g $u_i$ ( $\pm\%$ )	$v_i$
<b>Measurement System</b>									
Probe Calibration	E.2.1	5.9	N	1.00	1	1	5.9	5.9	$\infty$
Axial Isotropy	E.2.2	4.7	R	1.73	1	1	2.7	2.7	$\infty$
Spherical Isotropy	E.2.2	9.6	R	1.73	0	0	0.0	0.0	$\infty$
Boundary Effect	E.2.3	1.0	R	1.73	1	1	0.6	0.6	$\infty$
Linearity	E.2.4	4.7	R	1.73	1	1	2.7	2.7	$\infty$
System Detection Limits	E.2.5	1.0	R	1.73	1	1	0.6	0.6	$\infty$
Readout Electronics	E.2.6	0.3	N	1.00	1	1	0.3	0.3	$\infty$
Response Time	E.2.7	1.1	R	1.73	1	1	0.6	0.6	$\infty$
Integration Time	E.2.8	0.0	R	1.73	1	1	0.0	0.0	$\infty$
RF Ambient Conditions - Noise	E.6.1	3.0	R	1.73	1	1	1.7	1.7	$\infty$
RF Ambient Conditions - Reflections	E.6.1	0.0	R	1.73	1	1	0.0	0.0	$\infty$
Probe Positioner Mechanical Tolerance	E.6.2	0.4	R	1.73	1	1	0.2	0.2	$\infty$
Probe Positioning w.r.t. Phantom	E.6.3	1.4	R	1.73	1	1	0.8	0.8	$\infty$
Max. SAR Evaluation (ext., int., avg.)	E.5	3.4	R	1.73	1	1	2.0	2.0	$\infty$
<b>Dipole</b>									
Dipole Axis to Liquid Distance	8, E.4.2	2.0	R	1.73	1	1	1.2	1.2	$\infty$
Input Power and SAR Drift Measurement	8, 6.6.2	5.0	R	1.73	1	1	2.9	2.9	$\infty$
<b>Phantom and Tissue Parameters</b>									
Phantom Uncertainty	E.3.1	4.0	R	1.73	1	1	2.3	2.3	$\infty$
Liquid Conductivity (target)	E.3.2	5.0	R	1.73	0.64	0.43	1.8	1.2	$\infty$
Liquid Conductivity (measurement)	E.3.3	3.3	R	1.73	0.64	0.43	1.2	0.8	$\infty$
Liquid Permittivity (target)	E.3.2	5.0	R	1.73	0.6	0.49	1.7	1.4	$\infty$
Liquid Permittivity (measurement)	E.3.3	1.9	R	1.73	0.6	0.49	0.6	0.5	$\infty$
<b>Combined Standard Uncertainty</b>			RSS				9	9	99999
<b>Expanded Uncertainty (95% CONFIDENCE LEVEL)</b>			$k=2$				18	17	

Notes for Tables 1, 2, 3 and 4

- a) Column headings *a-k* are given for reference.
- b) Tol. - tolerance in influence quantity.
- c) Prob. Dist. – Probability distribution
- d) N, R - normal, rectangular probability distributions
- e) Div. - divisor used to translate tolerance into normally distributed standard uncertainty
- f)  $c_i$  - sensitivity coefficient that should be applied to convert the variability of the uncertainty component into a variability of SAR.
- g)  $u_i$  – SAR uncertainty
- h)  $v_i$  - degrees of freedom for standard uncertainty and effective degrees of freedom for the expanded uncertainty

**APPENDIX B**  
**Probe Calibration Certificates**

**Calibration Laboratory of  
Schmid & Partner  
Engineering AG**  
Zeughausstrasse 43, 8004 Zurich, Switzerland



**S** Schweizerischer Kalibrierdienst  
**C** Service suisse d'étalonnage  
**S** Servizio svizzero di taratura  
**S** Swiss Calibration Service

Accredited by the Swiss Accreditation Service (SAS)  
The Swiss Accreditation Service is one of the signatories to the EA  
Multilateral Agreement for the recognition of calibration certificates

Accreditation No.: **SCS 108**

Client: **Motorola CGISS**

Certificate No: **ES3-3147\_Feb09**

**CALIBRATION CERTIFICATE**

Object: **ES3DV3 - SN:3147**

Calibration procedure(s): **QA CAL-01.v6, QA CAL-12.v5, QA CAL-14.v3 and QA CAL-23.v3  
Calibration procedure for dosimetric E-field probes**

Calibration date: **February 13, 2009**

Condition of the calibrated item: **In Tolerance**

This calibration certificate documents the traceability to national standards, which realize the physical units of measurements (SI).  
The measurements and the uncertainties with confidence probability are given on the following pages and are part of the certificate.

All calibrations have been conducted in the closed laboratory facility: environment temperature (22 ± 3)°C and humidity < 70%.

Calibration Equipment used (M&TE critical for calibration)

Primary Standards	ID #	Cal Date (Certificate No.)	Scheduled Calibration
Power meter E4419B	GB41293874	1-Apr-08 (No. 217-00788)	Apr-09
Power sensor E4412A	MY41495277	1-Apr-08 (No. 217-00788)	Apr-09
Power sensor E4412A	MY41498087	1-Apr-08 (No. 217-00788)	Apr-09
Reference 3 dB Attenuator	SN: S5054 (3c)	1-Jul-08 (No. 217-00865)	Jul-09
Reference 20 dB Attenuator	SN: S5086 (20b)	31-Mar-08 (No. 217-00787)	Apr-09
Reference 30 dB Attenuator	SN: S5129 (30b)	1-Jul-08 (No. 217-00865)	Jul-09
Reference Probe ES3DV2	SN: 3013	2-Jan-09 (No. ES3-3013_Jan09)	Jan-10
DAE4	SN: 660	9-Sep-08 (No. DAE4-660_Sep08)	Sep-09
Secondary Standards	ID #	Check Date (in house)	Scheduled Check
RF generator HP 8648C	US3642U01700	4-Aug-99 (in house check Oct-07)	In house check: Oct-09
Network Analyzer HP 8753E	US37390585	18-Oct-01 (in house check Oct-08)	In house check: Oct-09

	Name	Function	Signature
Calibrated by:	Katja Pokovic	Technical Manager	
Approved by:	Nils Kuster	Quality Manager	

Issued: February 16, 2009

This calibration certificate shall not be reproduced except in full without written approval of the laboratory.

**Calibration Laboratory of  
Schmid & Partner  
Engineering AG**  
Zaughausstrasse 43, 8004 Zurich, Switzerland



**S** Schweizerischer Kallbriendienst  
**C** Service suisse d'étalonnage  
**S** Servizio svizzero di taratura  
**S** Swiss Calibration Service

Accredited by the Swiss Accreditation Service (SAS)  
The Swiss Accreditation Service is one of the signatories to the EA  
Multilateral Agreement for the recognition of calibration certificates

Accreditation No.: **SCS 108**

### Glossary:

TSL	tissue simulating liquid
NORM <sub>x,y,z</sub>	sensitivity in free space
ConvF	sensitivity in TSL / NORM <sub>x,y,z</sub>
DCP	diode compression point
Polarization $\varphi$	$\varphi$ rotation around probe axis
Polarization $\vartheta$	$\vartheta$ rotation around an axis that is in the plane normal to probe axis (at measurement center), i.e., $\vartheta = 0$ is normal to probe axis

### Calibration is Performed According to the Following Standards:

- IEEE Std 1528-2003, "IEEE Recommended Practice for Determining the Peak Spatial-Averaged Specific Absorption Rate (SAR) in the Human Head from Wireless Communications Devices: Measurement Techniques", December 2003
- IEC 62209-1, "Procedure to measure the Specific Absorption Rate (SAR) for hand-held devices used in close proximity to the ear (frequency range of 300 MHz to 3 GHz)", February 2005

### Methods Applied and Interpretation of Parameters:

- NORM<sub>x,y,z</sub>**: Assessed for E-field polarization  $\vartheta = 0$  ( $f \leq 900$  MHz in TEM-cell;  $f > 1800$  MHz: R22 waveguide). NORM<sub>x,y,z</sub> are only intermediate values, i.e., the uncertainties of NORM<sub>x,y,z</sub> does not effect the E<sup>2</sup>-field uncertainty inside TSL (see below *ConvF*).
- NORM(f)<sub>x,y,z</sub>** = NORM<sub>x,y,z</sub> \* *frequency\_response* (see Frequency Response Chart). This linearization is implemented in DASY4 software versions later than 4.2. The uncertainty of the frequency response is included in the stated uncertainty of *ConvF*.
- DCP<sub>x,y,z</sub>**: DCP are numerical linearization parameters assessed based on the data of power sweep (no uncertainty required). DCP does not depend on frequency nor media.
- ConvF and Boundary Effect Parameters**: Assessed in flat phantom using E-field (or Temperature Transfer Standard for  $f \leq 800$  MHz) and inside waveguide using analytical field distributions based on power measurements for  $f > 800$  MHz. The same setups are used for assessment of the parameters applied for boundary compensation (alpha, depth) of which typical uncertainty values are given. These parameters are used in DASY4 software to improve probe accuracy close to the boundary. The sensitivity in TSL corresponds to NORM<sub>x,y,z</sub> \* *ConvF* whereby the uncertainty corresponds to that given for *ConvF*. A frequency dependent *ConvF* is used in DASY version 4.4 and higher which allows extending the validity from  $\pm 50$  MHz to  $\pm 100$  MHz.
- Spherical isotropy (3D deviation from isotropy)**: in a field of low gradients realized using a flat phantom exposed by a patch antenna.
- Sensor Offset**: The sensor offset corresponds to the offset of virtual measurement center from the probe tip (on probe axis). No tolerance required.

**ES3DV3 SN:3147**

**February 13, 2009**

# Probe ES3DV3

## SN:3147

Manufactured:	July 12, 2007
Last calibrated:	August 18, 2008
Recalibrated:	February 13, 2009

**Calibrated for DASY Systems**

(Note: non-compatible with DASY2 system!)

ES3DV3 SN:3147

February 13, 2009

### DASY - Parameters of Probe: ES3DV3 SN:3147

Sensitivity in Free Space <sup>A</sup>			Diode Compression <sup>B</sup>	
NormX	1.25 ± 10.1%	μV/(V/m) <sup>2</sup>	DCP X	94 mV
NormY	1.22 ± 10.1%	μV/(V/m) <sup>2</sup>	DCP Y	95 mV
NormZ	1.20 ± 10.1%	μV/(V/m) <sup>2</sup>	DCP Z	93 mV

### Sensitivity in Tissue Simulating Liquid (Conversion Factors)

Please see Page 8.

### Boundary Effect

TSL	900 MHz	Typical SAR gradient: 5 % per mm	
	Sensor Center to Phantom Surface Distance	3.0 mm	4.0 mm
	SAR <sub>be</sub> [%] Without Correction Algorithm	9.5	5.4
	SAR <sub>be</sub> [%] With Correction Algorithm	0.8	0.4

TSL	1810 MHz	Typical SAR gradient: 10 % per mm	
	Sensor Center to Phantom Surface Distance	3.0 mm	4.0 mm
	SAR <sub>be</sub> [%] Without Correction Algorithm	8.3	4.8
	SAR <sub>be</sub> [%] With Correction Algorithm	0.9	0.5

### Sensor Offset

Probe Tip to Sensor Center **2.0 mm**

**The reported uncertainty of measurement is stated as the standard uncertainty of measurement multiplied by the coverage factor k=2, which for a normal distribution corresponds to a coverage probability of approximately 95%.**

<sup>A</sup> The uncertainties of NormX,Y,Z do not affect the E<sup>2</sup>-field uncertainty inside TSL (see Page 8).

<sup>B</sup> Numerical linearization parameter: uncertainty not required.

ES3DV3 SN:3147

February 13, 2009

### Frequency Response of E-Field

(TEM-Cell:ifi110 EXX, Waveguide: R22)

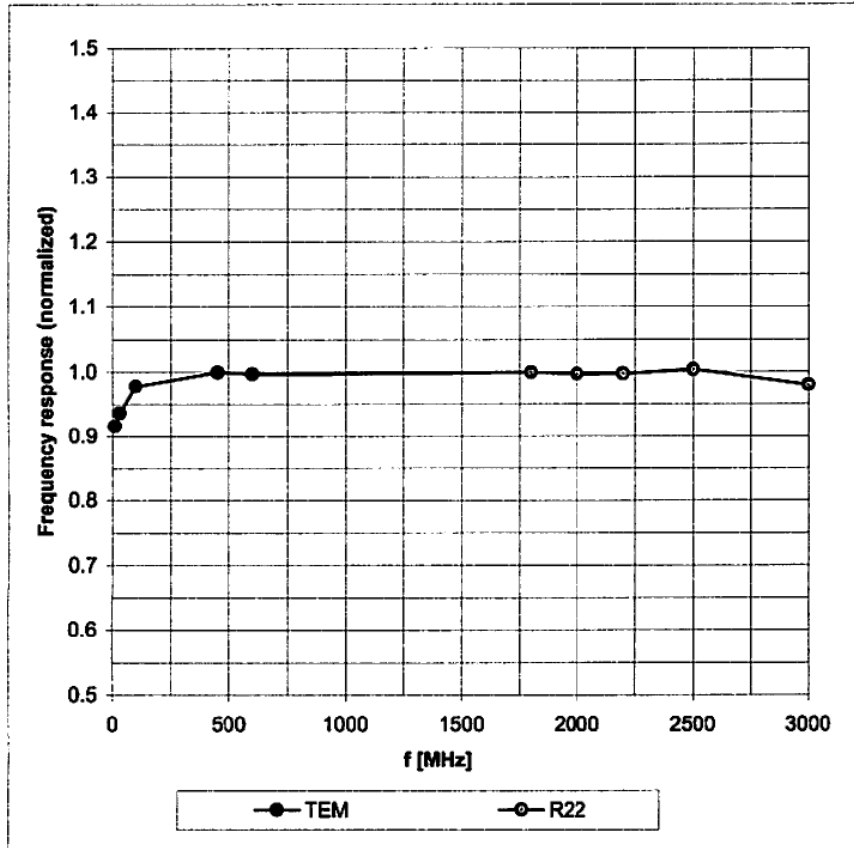

Uncertainty of Frequency Response of E-field:  $\pm 6.3\%$  (k=2)

ES3DV3 SN:3147

February 13, 2009

### Receiving Pattern ( $\phi$ ), $\vartheta = 0^\circ$

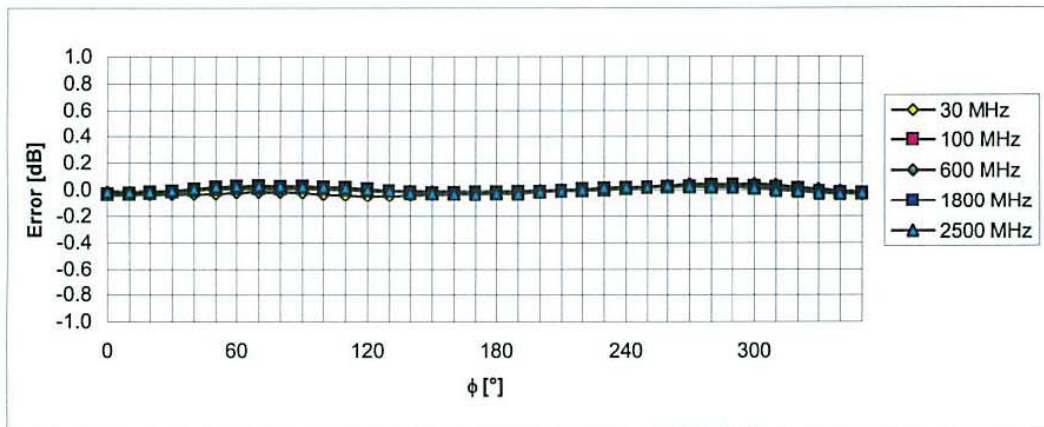
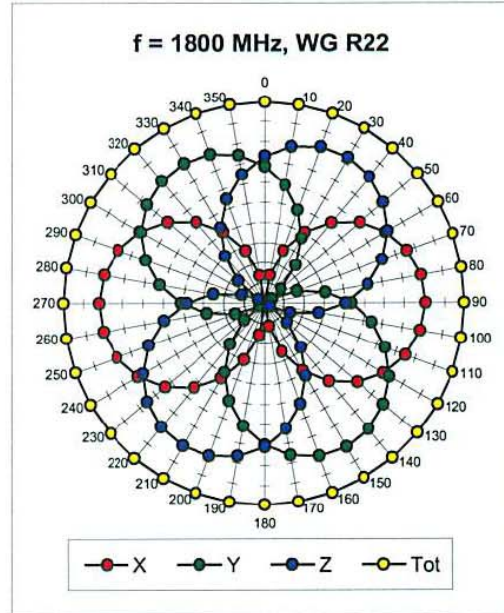
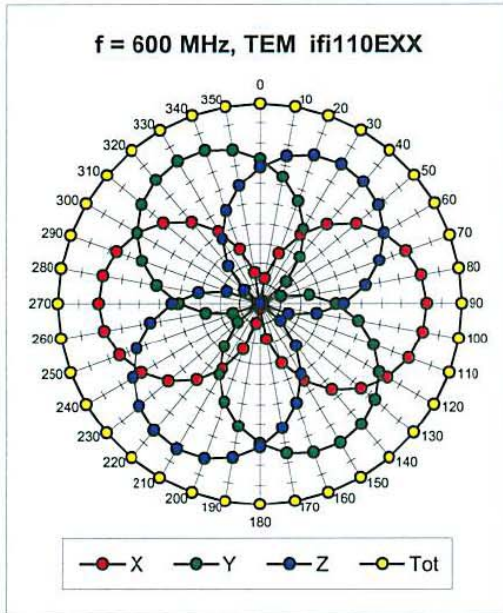

Uncertainty of Axial Isotropy Assessment:  $\pm 0.5\%$  ( $k=2$ )

ES3DV3 SN:3147

February 13, 2009

### Dynamic Range $f(\text{SAR}_{\text{head}})$ (Waveguide R22, $f = 1800 \text{ MHz}$ )

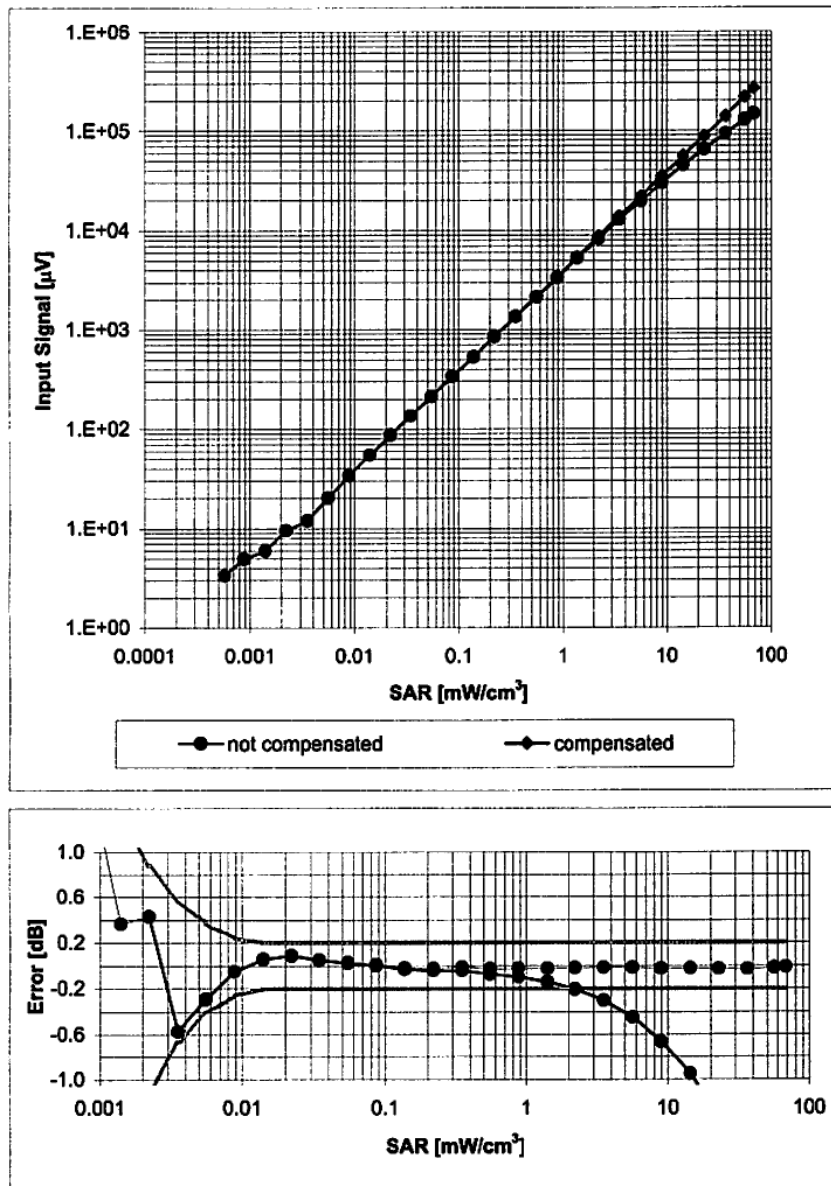

Uncertainty of Linearity Assessment:  $\pm 0.6\%$  ( $k=2$ )

ES3DV3 SN:3147

February 13, 2009

### Conversion Factor Assessment

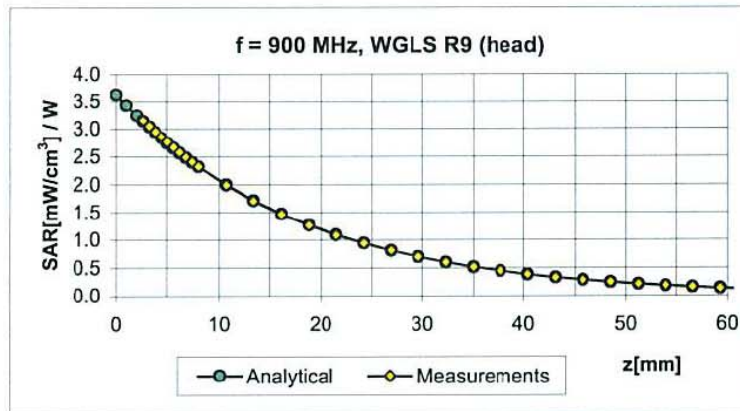

f [MHz]	Validity [MHz] <sup>c</sup>	TSL	Permittivity	Conductivity	Alpha	Depth	ConvF Uncertainty
450	± 50 / ± 100	Head	43.5 ± 5%	0.87 ± 5%	0.31	1.51	6.31 ± 13.3% (k=2)
900	± 50 / ± 100	Head	41.5 ± 5%	0.97 ± 5%	0.88	1.10	5.86 ± 11.0% (k=2)
1810	± 50 / ± 100	Head	40.0 ± 5%	1.40 ± 5%	0.42	1.62	4.97 ± 11.0% (k=2)
1950	± 50 / ± 100	Head	40.0 ± 5%	1.40 ± 5%	0.41	1.62	4.81 ± 11.0% (k=2)
2300	± 50 / ± 100	Head	39.4 ± 5%	1.71 ± 5%	0.35	1.87	4.70 ± 11.0% (k=2)
2450	± 50 / ± 100	Head	39.2 ± 5%	1.80 ± 5%	0.40	1.81	4.46 ± 11.0% (k=2)
2600	± 50 / ± 100	Head	39.0 ± 5%	1.96 ± 5%	0.41	1.84	4.38 ± 11.0% (k=2)
3500	± 50 / ± 100	Head	37.9 ± 5%	2.91 ± 5%	0.90	1.22	3.92 ± 13.1% (k=2)
3700	± 50 / ± 100	Head	37.7 ± 5%	3.12 ± 5%	0.90	1.22	3.53 ± 13.1% (k=2)
450	± 50 / ± 100	Body	56.7 ± 5%	0.94 ± 5%	0.24	1.33	6.69 ± 13.3% (k=2)
900	± 50 / ± 100	Body	55.0 ± 5%	1.05 ± 5%	0.79	1.17	5.80 ± 11.0% (k=2)
1810	± 50 / ± 100	Body	53.3 ± 5%	1.52 ± 5%	0.41	1.44	4.73 ± 11.0% (k=2)
1950	± 50 / ± 100	Body	53.3 ± 5%	1.52 ± 5%	0.38	1.49	4.69 ± 11.0% (k=2)
2300	± 50 / ± 100	Body	52.8 ± 5%	1.85 ± 5%	0.83	1.13	4.26 ± 11.0% (k=2)
2450	± 50 / ± 100	Body	52.7 ± 5%	1.95 ± 5%	0.80	1.16	4.06 ± 11.0% (k=2)
2600	± 50 / ± 100	Body	52.5 ± 5%	2.16 ± 5%	0.99	1.08	3.99 ± 11.0% (k=2)
3500	± 50 / ± 100	Body	51.3 ± 5%	3.31 ± 5%	0.90	1.20	3.49 ± 13.1% (k=2)
3700	± 50 / ± 100	Body	51.0 ± 5%	3.55 ± 5%	0.90	1.20	3.40 ± 13.1% (k=2)

<sup>c</sup> The validity of ± 100 MHz only applies for DASY v4.4 and higher (see Page 2). The uncertainty is the RSS of the ConvF uncertainty at calibration frequency and the uncertainty for the indicated frequency band.

ES3DV3 SN:3147

February 13, 2009

### Deviation from Isotropy in HSL

Error ( $\phi, \vartheta$ ),  $f = 900$  MHz

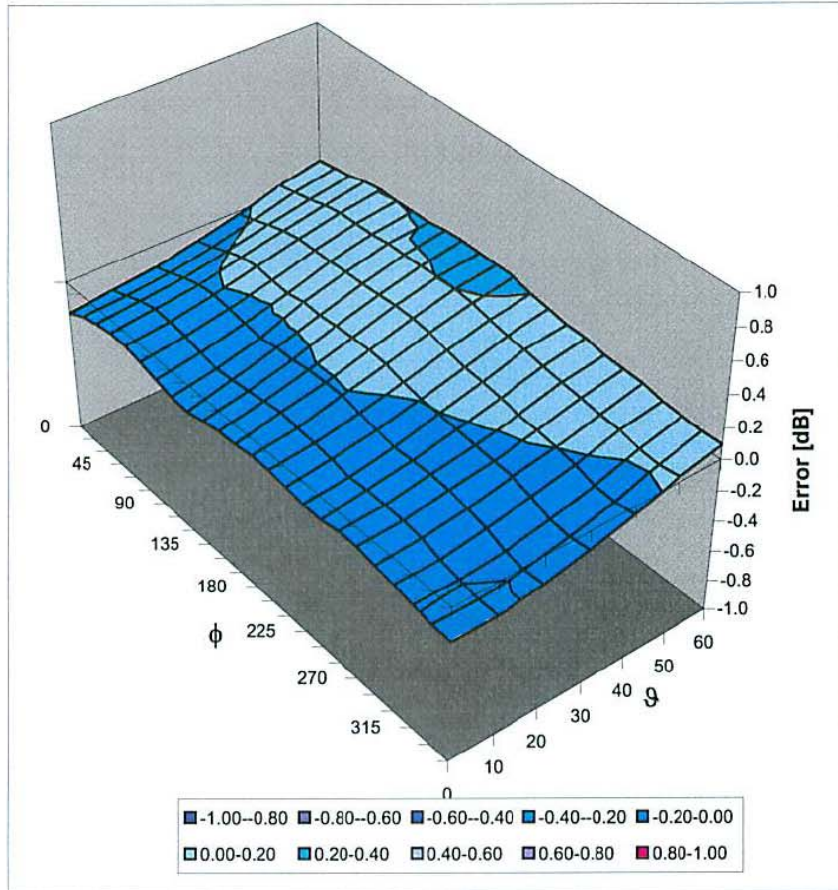

Uncertainty of Spherical Isotropy Assessment:  $\pm 2.6\%$  ( $k=2$ )

Schmid & Partner Engineering AG

**s p e a g**

Zeughausstrasse 43, 8004 Zurich, Switzerland  
Phone +41 44 245 9700, Fax +41 44 245 9779  
info@speag.com, http://www.speag.com

### Additional Conversion Factors for Dosimetric E-Field Probe

Type:	<b>ES3DV3</b>
Serial Number:	<b>3147</b>
Place of Assessment:	<b>Zurich</b>
Date of Assessment:	<b>February 17, 2009</b>
Probe Calibration Date:	<b>February 13, 2009</b>

Schmid & Partner Engineering AG hereby certifies that conversion factor(s) of this probe have been evaluated on the date indicated above. The assessment was performed using the FDTD numerical code SEMCAD of Schmid & Partner Engineering AG. Since the evaluation is coupled with measured conversion factors, it has to be recalculated yearly, i.e., following the re-calibration schedule of the probe. The uncertainty of the numerical assessment is based on the extrapolation from measured value at 900 MHz or at 1810 MHz.

Assessed by: 

Schmid & Partner Engineering AG

**s p e a g**

Zeughausstrasse 43, 8004 Zurich, Switzerland  
 Phone +41 44 245 9700, Fax +41 44 245 9779  
 info@speag.com, http://www.speag.com

**Dosimetric E-Field Probe ES3DV3 SN:3147**

Conversion factor ( $\pm$  standard deviation)

150 MHz	<i>ConvF</i>	$8.0 \pm 10\%$	$\epsilon_r = 52.3$ $\sigma = 0.76 \text{ mho/m}$ (head tissue)
250 MHz	<i>ConvF</i>	$7.2 \pm 10\%$	$\epsilon_r = 47.6$ $\sigma = 0.83 \text{ mho/m}$ (head tissue)
300 MHz	<i>ConvF</i>	$7.2 \pm 9\%$	$\epsilon_r = 45.3$ $\sigma = 0.87 \text{ mho/m}$ (head tissue)
750 MHz	<i>ConvF</i>	$6.1 \pm 7\%$	$\epsilon_r = 41.9$ $\sigma = 0.89 \text{ mho/m}$ (head tissue)
150 MHz	<i>ConvF</i>	$7.7 \pm 10\%$	$\epsilon_r = 61.9$ $\sigma = 0.80 \text{ mho/m}$ (body tissue)
250 MHz	<i>ConvF</i>	$7.3 \pm 10\%$	$\epsilon_r = 59.4$ $\sigma = 0.88 \text{ mho/m}$ (body tissue)
300 MHz	<i>ConvF</i>	$7.2 \pm 9\%$	$\epsilon_r = 58.2$ $\sigma = 0.92 \text{ mho/m}$ (body tissue)
750 MHz	<i>ConvF</i>	$5.9 \pm 7\%$	$\epsilon_r = 55.5$ $\sigma = 0.96 \text{ mho/m}$ (body tissue)

**Important Note:**

**For numerically assessed probe conversion factors, parameters Alpha and Delta in the DASY software must have the following entries: Alpha = 0 and Delta = 1.**

**Please see also Section 4.7 of the DASY4 Manual.**

**Note: The standard deviation for each Conversion factor stated in above numerical assessments were taken at  $k = 1$ .**