



FCC Test Report

EQUIPMENT : Attila 2.5G without WiFi
BRAND NAME : Moto A3000
MODEL NAME : A3000
FCC ID : IHDP56JH3
STANDARD : FCC 47 CFR FCC Part 15 Subpart B
CLASSIFICATION : Declaration of Conformity
APPLICANT : Motorola Inc.
600 N. US Highway 45, Libertyville, IL 60048

The product sample received on Sep. 24, 2008 and completely tested on Oct. 15, 2008. We, SPORTON INTERNATIONAL INC., would like to declare that the tested sample has been evaluated in accordance with the procedures given in ANSI C63.4-2003 and shown the compliance with the applicable technical standards.

The test results in this report apply exclusively to the tested model / sample. Without written approval of SPORTON INTERNATIONAL INC., the test report shall not be reproduced except in full.

Reviewed by: Roy Wu / Manager



Lab Code: 200079-0

SPORTON INTERNATIONAL INC.

No. 52, Hwa Ya 1st Rd., Hwa Ya Technology Park, Kwei-Shan Hsiang, Tao Yuan Hsien, Taiwan, R.O.C.



TABLE OF CONTENTS

SUMMARY OF TEST RESULT 3

REVISION HISTORY..... 4

1. GENERAL DESCRIPTION 5

 1.1 Applicant..... 5

 1.2 Manufacturer 5

 1.3 Feature of Equipment Under Test..... 5

 1.4 Test Site 6

 1.5 Applied Standards 7

 1.6 Ancillary Equipment List..... 7

2. TEST CONFIGURATION OF EQUIPMENT UNDER TEST 8

 2.1 Test Mode 8

 2.2 Connection Diagram of Test System 9

 2.3 Test Software 10

3. TEST RESULT 11

 3.1 Test of AC Conducted Emission Measurement 11

 3.2 Test of Radiated Emission Measurement 15

4. LIST OF MEASURING EQUIPMENTS 21

5. UNCERTAINTY OF EVALUATION 22

6. CERTIFICATION OF NVLAP ACCREDITATION 24

APPENDIX A. PHOTOGRAPHS OF EUT

APPENDIX B. SETUP PHOTOGRAPHS



SUMMARY OF TEST RESULT

Report Section	FCC Rule	IC Rule	Description	Limit	Result	Remark
3.1	15.107	7.2.2	AC Conducted Emission	< 15.107 limits < RSS-Gen table 2 limits	PASS	Under limit 6.5 dB at 0.406 MHz
3.2	15.109	7.2.3.2	Radiated Emission	< 15.109 limits or < RSS-Gen table 1 limits (Section 6)	PASS	Under limit 7.59 dB at 39.18 MHz



1. General Description

1.1 Applicant

Motorola Inc.
600 N. US Highway 45, Libertyville, IL 60048

1.2 Manufacturer

Motorola Inc.
600 N. US Highway 45, Libertyville, IL 60048

1.3 Feature of Equipment Under Test

Product Feature & Specification	
Equipment	Attila 2.5G without WiFi
Brand Name	Moto A3000
Model Name	A3000
Tx Frequency Range	GSM850 : 824 MHz ~ 849 MHz GSM1900 : 1850 MHz ~ 1910 MHz Bluetooth : 2400 MHz ~ 2483.5 MHz
Rx Frequency Range	GSM850 : 869 MHz ~ 894 MHz GSM1900 : 1930 MHz ~ 1990 MHz Bluetooth : 2400 MHz ~ 2483.5 MHz
Antenna Type	Fixed Internal Antenna
Antenna Connector Type	N/A
HW Version	0C
SW Version	1.03
Type of Modulation	GSM : GMSK Bluetooth (1Mbps) : GFSK Bluetooth EDR (2Mbps) : $\pi/4$ -DQPSK Bluetooth EDR (3Mbps) : 8-DPSK
EUT Stage	Production Unit

2nd component Source List

Component Model		
AC Adapter	Brand Name	Motorola
	Model Name	FMP5202C
	Product Number	SPN5328B
	Power Rating	I/P: 100-240Vac, 50-60Hz, 120mA; O/P: 5Vdc, 850mA
	AC Power Cord Type	1.95 meter non-shielded cable without ferrite core
Battery	Brand Name	Motorola
	Model Name	BT60
	Power Rating	3.7Vdc, 1130mAh
	Type	Li-ion
Earphone	Brand Name	Motorola
	Model Name	SYN1302A
	Signal Line Type	1.2 meter non-shielded cable without ferrite core
USB Cable	Brand Name	Motorola
	Model Name	CUNC004B-T71-EF
	Signal Line Type	1.5 meter shielded cable without ferrite core
LCD Panel	Brand Name	Topoly
	Model Name	99000343

Remark:

1. The above EUT's information was declared by manufacturer. Please refer to the specifications or user's manual for more detailed description.
2. For accessories equipped with this EUT, please refer to the appendix of the external photo.

1.4 Test Site

Test Site	SPORTON INTERNATIONAL INC.		
Test Site Location	No. 52, Hwa Ya 1 st Rd., Hwa Ya Technology Park, Kwei-Shan Hsiang, Tao Yuan Hsien, Taiwan, R.O.C TEL: +886-3-327-3456 FAX: +886-3-328-4978		
Test Site No.	Sporton Site No.		FCC/IC Registration No.
	CO05-HY	03CH06-HY	TW1022/4086B-1

1.5 Applied Standards

According to the specifications of the manufacturer, the EUT must comply with the requirements of the following standards:

- FCC 47 CFR FCC Part 15 Subpart B
- ANSI C63.4-2003
- RSS-Gen Issue 2

Remark: All test items were verified and recorded according to the standards and without any deviation during the test.

1.6 Ancillary Equipment List

Item	Equipment	Trade Name	Model Name	FCC ID	Data Cable	Power Cord
1.	GSM Base Station	R&S	CMU 200	N/A	N/A	Unshielded, 1.8 m
2.	Notebook	DELL	D400	E2K24GBRL	N/A	AC I/P: Unshielded, 1.2 m DC O/P: Shielded, 1.8 m
3.	Earphone + Mic	Sampo	EK-Y652CS	FCC DoC	Shielded, 1.8 m	N/A
4.	Bluetooth Earphone	Samsung	WEP410	A3LWEP410	N/A	N/A
5.	RS-232 Mouse	State	MS-303	FCC DoC	Unshielded, 1.3 m	N/A
6.	i-pod	Apple	A1199	FCC DoC	Shielded, 1.0 m	N/A

2. Test Configuration of Equipment Under Test

2.1 Test Mode

The EUT has been associated with peripherals pursuant to ANSI C63.4-2003 and configuration operated in a manner tended to maximize its emission characteristics in a typical application.

Frequency range investigated: conduction (150 kHz to 30 MHz), radiation (30MHz to the 5th harmonic of the highest fundamental frequency or to 40 GHz, whichever is lower).

Pre-scanned tests were conducted to determine the final configuration from all possible combinations.

The following tables are showing the test modes as the worst cases and recorded in this report.

EUT Configure Mode	Mode Description	Test Condition		
		EMI AC	EMI RE<1G	EMI RE≥1G
1	Charging Mode (EUT with adapter)	✓	✓	Note 1
2	Charging Mode (EUT with notebook PC)	✓	✓	✓

Abbreviations:

EMI AC: AC conducted emissions ; EMI RE ≥ 1G: EUT radiated emissions ≥ 1GHz;

EMI RE < 1G: EUT radiated emissions < 1GHz ;

Note 1: Testing for this mode is not required.

Test Items	EUT Configure Mode	Function Type
AC Conducted Emission	1/2	Mode 1: GSM850 Idle + BT Idle + Earphone + Camera + Adapter Mode 2: GSM850 Idle + BT Idle + Earphone + MPEG4 + Adapter Mode 3: GSM850 Idle + BT Idle + Earphone + Camera + USB Link Mode 4: GSM1900 Idle + BT Idle + Earphone + Camera + Adapter
Radiated Emissions < 1GHz	1/2	Mode 1: GSM850 Idle + BT Idle + Earphone + Camera + Adapter Mode 2: GSM850 Idle + BT Idle + Earphone + MPEG4 + Adapter Mode 3: GSM850 Idle + BT Idle + Earphone + MPEG4 + USB Link Mode 4: GSM1900 Idle + BT Idle + Earphone + MPEG4 + USB Link
Radiated Emissions ≥ 1GHz	2	Mode 1: GSM1900 Idle + BT Idle + Earphone + MPEG4 + USB Link
Remark: The boldface cases were the worst cases of the testing; only the worst data were reported.		

2.2 Connection Diagram of Test System

<EUT with Adapter Mode>

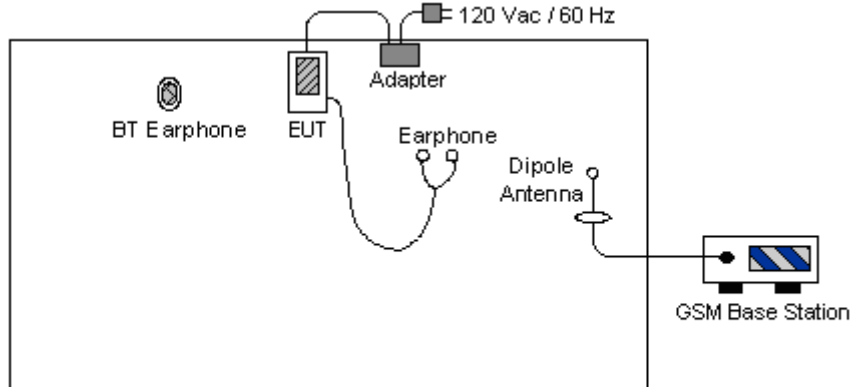

<EUT with USB Link Mode for Conducted Emission>

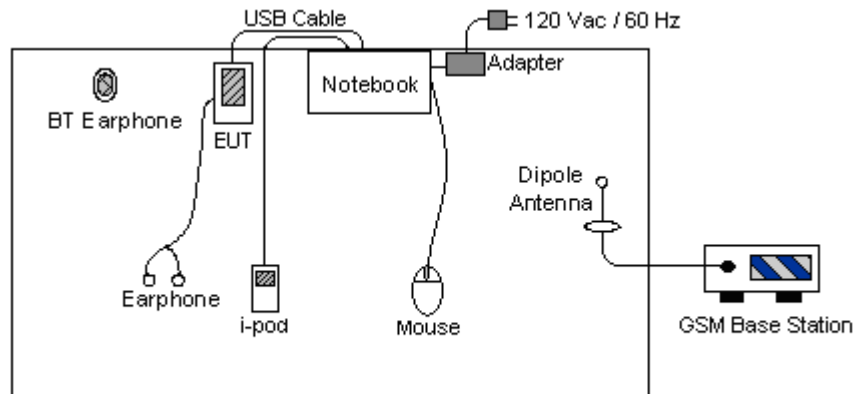

<EUT with USB Link Mode for Radiated Emissions>

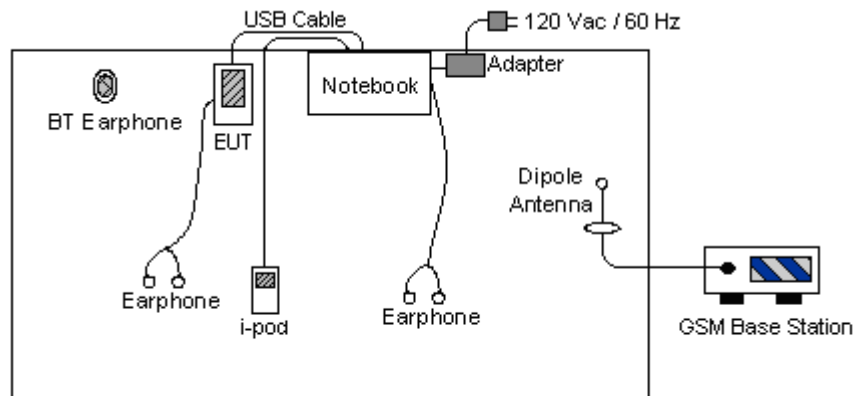



2.3 Test Software

For associated equipment, the executive program, "EMCTesr.exe", "Activesync.exe" and "EMI.Test" on notebook WINXP can generate a complete line of continuously repeating "H" pattern.

The programs were executed as follows:

- a. Turn on the power of all equipment.
- b. The notebook reads the test program from the hard disk drive and runs it.
- c. The notebook sends "H" messages to the panel, and the panel displays "H" patterns on the screen.
- d. The notebook sends "H" messages to the internal hard disk, and the hard disk reads and writes the message.
- e. Repeat the steps from b to d.

In GSM idle mode, the EUT is synchronized to the BCCH, and is in continuous receiving mode by setting system simulator's paging reorganization.

At the same time, the EUT was linked with Bluetooth earphone.

3. Test Result

3.1 Test of AC Conducted Emission Measurement

3.1.1 Limits of AC Conducted Emission

For equipment that is designed to be connected to the public utility (AC) power line, the radio frequency voltage that is conducted back onto the AC power line on any frequency or frequencies within the band 150 kHz to 30 MHz shall not exceed the limits in the following table.

Frequency of emission (MHz)	Conducted limit (dBuV)	
	Quasi-peak	Average
0.15-0.5	66 to 56*	56 to 46*
0.5-5	56	46
5-30	60	50

*Decreases with the logarithm of the frequency.

3.1.2 Measuring Instruments

See list of measuring instruments of this test report.

3.1.3 Test Procedure

1. The EUT was placed 0.4 meter from the conducting wall of the shielding room was kept at least 80 centimeters from any other grounded conducting surface.
2. Connect EUT to the power mains through a line impedance stabilization network (LISN).
3. All the support units are connecting to the other LISN.
4. The LISN provides 50 ohm coupling impedance for the measuring instrument.
5. The FCC states that a 50 ohm, 50 microhenry LISN should be used.
6. Both sides of AC line were checked for maximum conducted interference.
7. The frequency range from 150 kHz to 30 MHz was searched.
8. Set the test-receiver system to Peak Detect Function and specified bandwidth with Maximum Hold Mode.

3.1.4 Test Setup

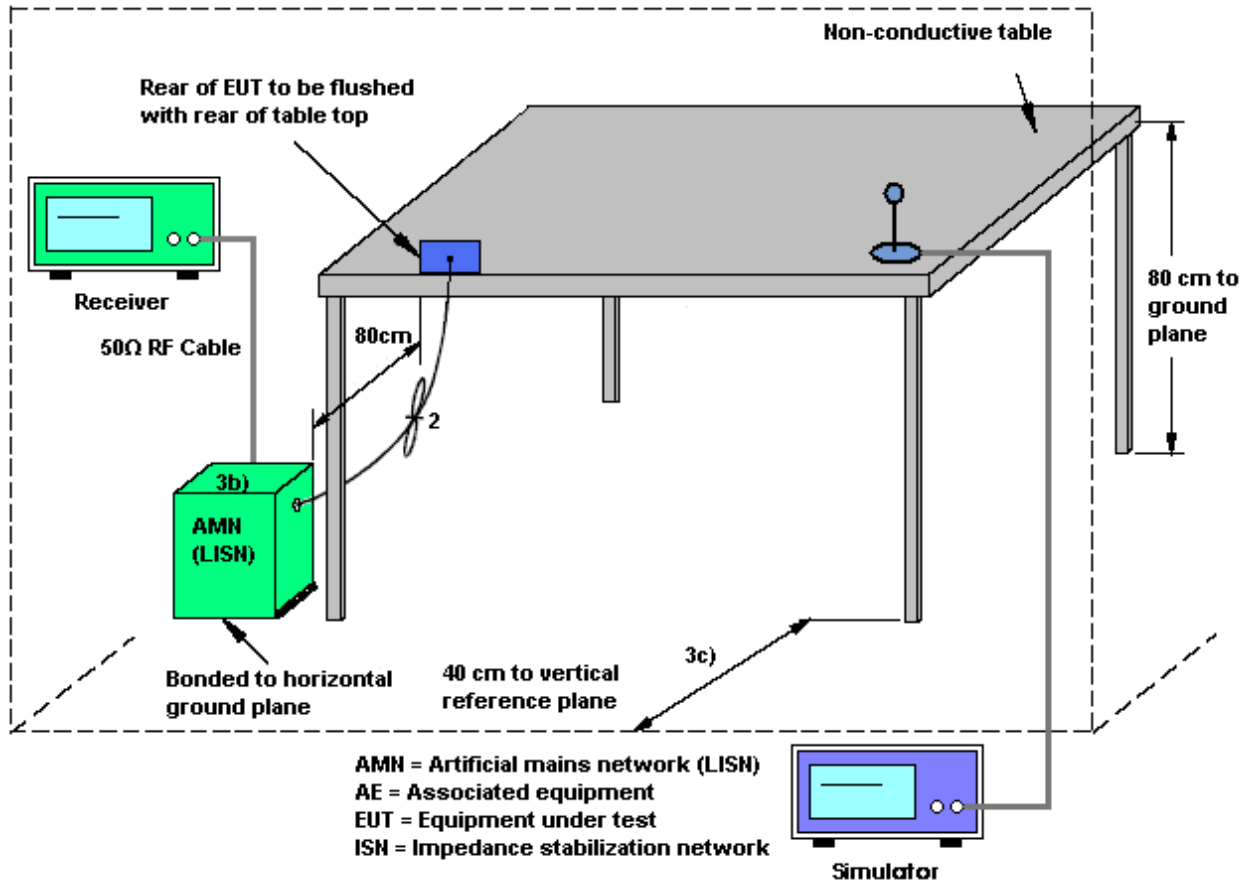

3.1.5 Test Result of AC Conducted Emission

Test Mode :	Mode 1	Temperature :	24~25°C
Test Engineer :	Cona Huang	Relative Humidity :	50~51%
		Phase :	Line
Function Type :	GSM850 Idle + BT Idle + Earphone + Camera + Adapter		
Remark :	All emissions not reported here are more than 10 dB below the prescribed limit.		

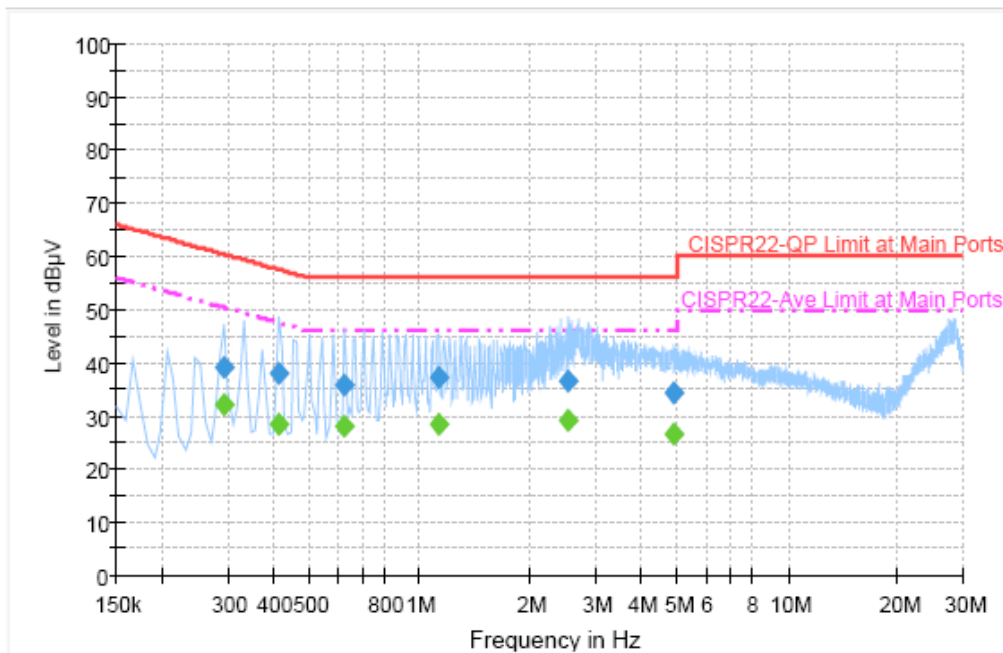

Final Result 1

Frequency (MHz)	QuasiPeak (dBµV)	Filter	Line	Corr. (dB)	Margin (dB)	Limit (dBµV)
0.294000	39.0	Off	L1	19.3	21.4	60.4
0.414000	38.1	Off	L1	19.4	19.5	57.6
0.622000	35.8	Off	L1	19.3	20.2	56.0
1.126000	37.2	Off	L1	19.4	18.8	56.0
2.542000	36.6	Off	L1	19.4	19.4	56.0
4.910000	34.2	Off	L1	19.5	21.8	56.0

Final Result 2

Frequency (MHz)	Average (dBµV)	Filter	Line	Corr. (dB)	Margin (dB)	Limit (dBµV)
0.294000	32.0	Off	L1	19.3	18.4	50.4
0.414000	28.5	Off	L1	19.4	19.1	47.6
0.622000	28.1	Off	L1	19.3	17.9	46.0
1.126000	28.4	Off	L1	19.4	17.6	46.0
2.542000	29.2	Off	L1	19.4	16.8	46.0
4.910000	26.7	Off	L1	19.5	19.3	46.0

Test Mode :	Mode 1	Temperature :	24~25°C
Test Engineer :	Cona Huang	Relative Humidity :	50~51%
		Phase :	Neutral
Function Type :	GSM850 Idle + BT Idle + Earphone + Camera + Adapter		
Remark :	All emissions not reported here are more than 10 dB below the prescribed limit.		

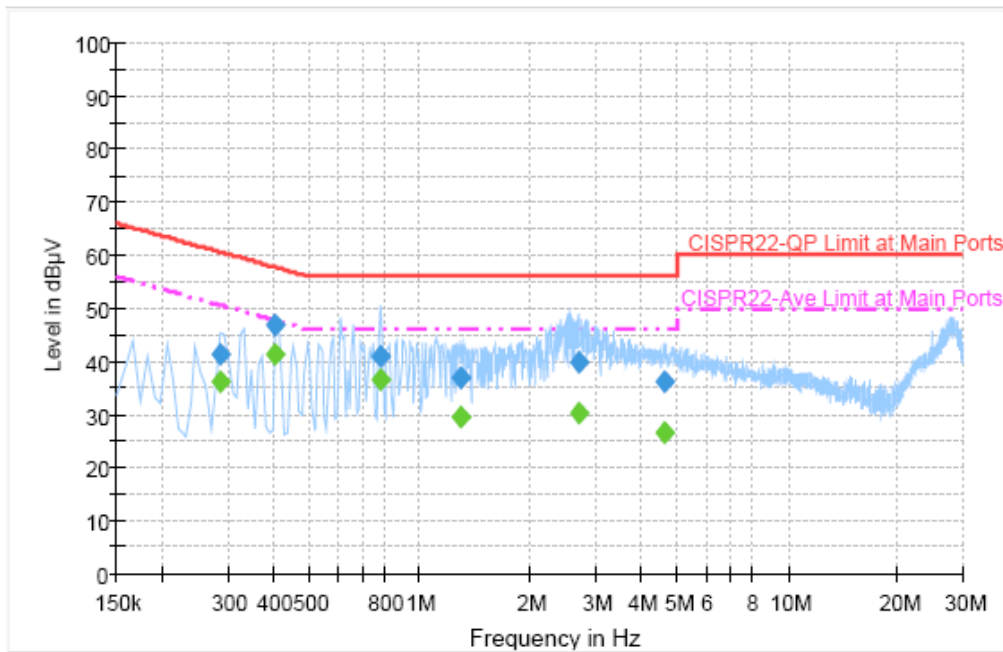

Final Result 1

Frequency (MHz)	QuasiPeak (dBµV)	Filter	Line	Corr. (dB)	Margin (dB)	Limit (dBµV)
0.286000	41.3	Off	N	19.3	19.3	60.6
0.406000	46.7	Off	N	19.4	11.0	57.7
0.782000	41.1	Off	N	19.4	14.9	56.0
1.286000	36.9	Off	N	19.5	19.1	56.0
2.702000	39.7	Off	N	19.5	16.3	56.0
4.606000	36.0	Off	N	19.6	20.0	56.0

Final Result 2

Frequency (MHz)	Average (dBµV)	Filter	Line	Corr. (dB)	Margin (dB)	Limit (dBµV)
0.286000	36.1	Off	N	19.3	14.5	50.6
0.406000	41.2	Off	N	19.4	6.5	47.7
0.782000	36.5	Off	N	19.4	9.5	46.0
1.286000	29.5	Off	N	19.5	16.5	46.0
2.702000	30.2	Off	N	19.5	15.8	46.0
4.606000	26.4	Off	N	19.6	19.6	46.0

3.2 Test of Radiated Emission Measurement

3.2.1 Limit of Radiated Emission

The emissions from an intentional radiator shall not exceed the field strength levels specified in the following table:

Frequency (MHz)	Field Strength (microvolts/meter)	Measurement Distance (meters)
0.009 – 0.490	2400/F(kHz)	300
0.490 – 1.705	24000/F(kHz)	30
1.705 – 30.0	30	30
30 – 88	100	3
88 – 216	150	3
216 - 960	200	3
Above 960	500	3

3.2.2 Measuring Instruments

See list of measuring instruments of this test report.

3.2.3 Test Procedures

1. The EUT was placed on a turntable with 0.8 meter above ground.
2. The EUT was set 3 meters from the interference receiving antenna, which was mounted on the top of a variable height antenna tower.
3. The table was rotated 360 degrees to determine the position of the highest radiation.
4. The antenna is a Bi-Log antenna and its height is adjusted between one meter and four meters above ground to find the maximum value of the field strength for both horizontal polarization and vertical polarization of the antenna.
5. For each suspected emission, the EUT was arranged to its worst case and then tune the antenna tower (from 1 m to 4 m) and turntable (from 0 degree to 360 degrees) to find the maximum reading.
6. Set the test-receiver system to Peak Detect Function and specified bandwidth with Maximum Hold Mode.
7. If the emission level of the EUT in peak mode was 3 dB lower than the limit specified, then testing will be stopped and peak values of EUT will be reported, otherwise, the emissions will be repeated one by one using the quasi-peak method and reported
8. Emission level (dBuV/m) = 20 log Emission level (uV/m)
9. Corrected Reading: Probe Factor + Cable Loss + Read Level - Preamp Factor = Level

3.2.4 Test Setup of Radiated Emission

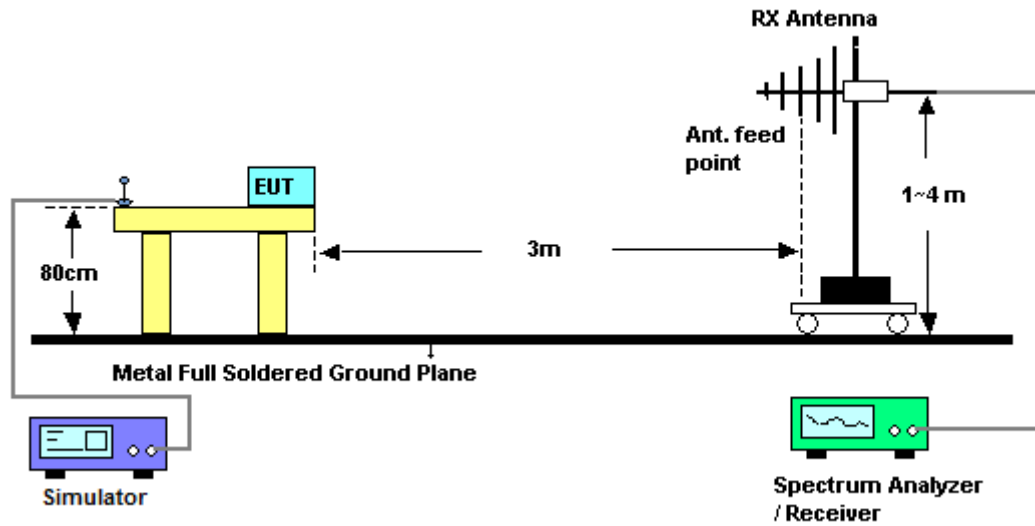



3.2.5 Test Result of Radiated Emission < 1GHz

Test Mode :	Mode 4	Temperature :	25~26°C
Test Engineer :	Mac Lin	Relative Humidity :	51~53%
Test Distance :	3m	Polarization :	Horizontal
Function Type :	GSM1900 Idle + BT Idle + Earphone + MPEG4 + USB Link		

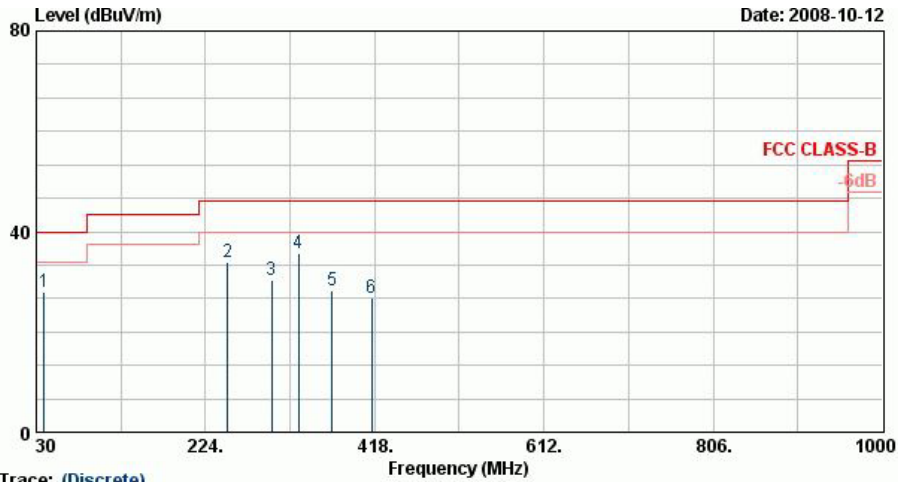

Site : 03CH06-HY
 Condition : FCC CLASS-B 3m LF-ANT(851121) HORIZONTAL
 Power : From System
 Model : FD 892435
 Name : Mode 4

Trace: (Discrete)

	Freq	Level	Over Limit	Limit Line	ReadAntenna Level	Antenna Factor	Cable Loss	Preamp Factor	Ant Pos	Table Pos	Remark
	MHz	dBuV/m	dB	dBuV/m	dBuV	dB/m	dB	dB	cm	deg	
1	39.18	27.93	-12.07	46.00	45.32	14.03	0.30	31.72	---	---	Peak
2	249.78	33.90	-12.10	46.00	52.72	12.27	0.70	31.79	---	---	Peak
3	299.73	30.25	-15.75	46.00	48.49	13.21	0.70	32.15	---	---	Peak
4	330.80	35.81	-10.19	46.00	52.88	14.00	0.80	31.87	100	314	Peak
5	369.30	28.21	-17.79	46.00	44.19	14.99	0.79	31.77	---	---	Peak
6	414.80	26.72	-19.28	46.00	41.79	16.02	0.85	31.94	---	---	Peak



Test Mode :	Mode 4	Temperature :	25~26°C
Test Engineer :	Mac Lin	Relative Humidity :	51~53%
Test Distance :	3m	Polarization :	Vertical
Function Type :	GSM1900 Idle + BT Idle + Earphone + MPEG4 + USB Link		

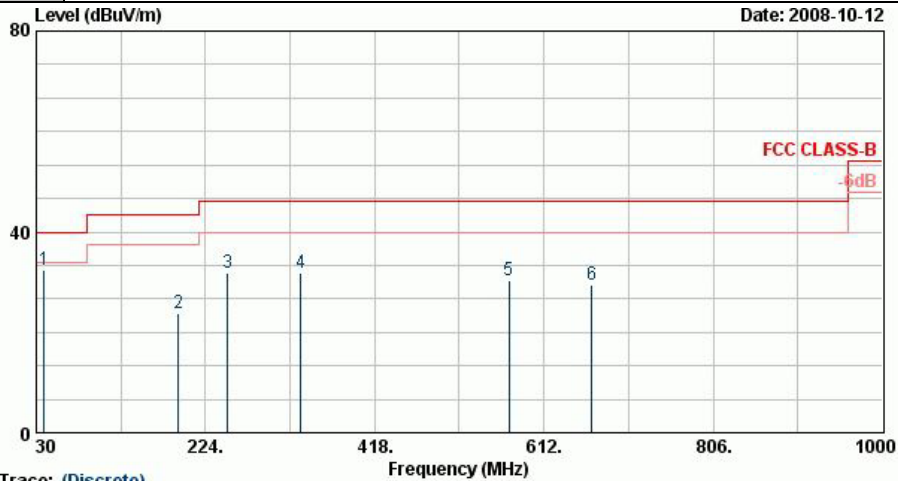

Trace: (Discrete)
 Site : 03CH06-HY
 Condition : FCC CLASS-B 3m LF-ANT(051121) VERTICAL
 Power : From System
 Model : FD 892435
 Mode : Mode 4

	Freq	Level	Over Limit	Limit Line	ReadAntenna Level	Antenna Factor	Cable Loss	Preamp Factor	Ant Pos	Table Pos	Remark
	MHz	dBuV/m	dB	dBuV/m	dBuV	dB/m	dB	dB	cm	deg	
1	39.18	32.41	-7.59	40.00	49.79	14.03	0.30	31.72	100	173	Peak
2	192.54	23.88	-19.62	43.50	45.98	9.35	0.60	32.05	---	---	Peak
3	249.24	31.92	-14.08	46.00	50.80	12.21	0.70	31.80	---	---	Peak
4	332.90	31.85	-14.15	46.00	48.85	14.05	0.80	31.85	---	---	Peak
5	572.30	30.44	-15.56	46.00	43.41	18.18	1.00	32.15	---	---	Peak
6	666.80	29.54	-16.46	46.00	41.84	18.75	1.04	32.08	---	---	Peak



3.2.6 Test Result of Radiated Emission ≥ 1 GHz

Test Mode :	Mode 1	Temperature :	25~26°C
Test Engineer :	Mac Lin	Relative Humidity :	51~53%
Test Distance :	3m	Polarization :	Horizontal
Function Type :	GSM1900 Idle + BT Idle + Earphone + MPEG4 + USB Link		

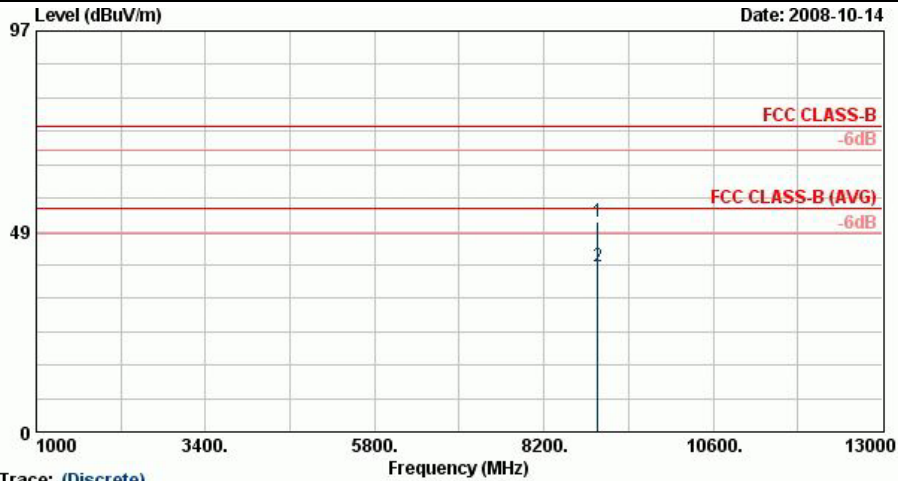

Trace: (Discrete)
 Site : 03CH06-HY
 Condition : FCC CLASS-B 3m HF-ANT(8-16)-060918 HORIZONTAL
 Power : From System
 Model : FD 892435
 Name : Mode 4

	Freq	Level	Over Limit	Limit Line	ReadAntenna Level	Antenna Factor	Cable Loss	Preamp Factor	Ant Pos	Table Pos	Remark
	MHz	dBuV/m	dB	dBuV/m	dBuV	dB/m	dB	dB	cm	deg	
1	8958.00	50.99	-23.01	74.00	43.64	36.15	7.77	36.57	100	0	Peak
2	8958.00	39.89	-14.11	54.00	32.54	36.15	7.77	36.57	100	182	Average



Test Mode :	Mode 1	Temperature :	25~26°C
Test Engineer :	Mac Lin	Relative Humidity :	51~53%
Test Distance :	3m	Polarization :	Vertical
Function Type :	GSM1900 Idle + BT Idle + Earphone + MPEG4 + USB Link		

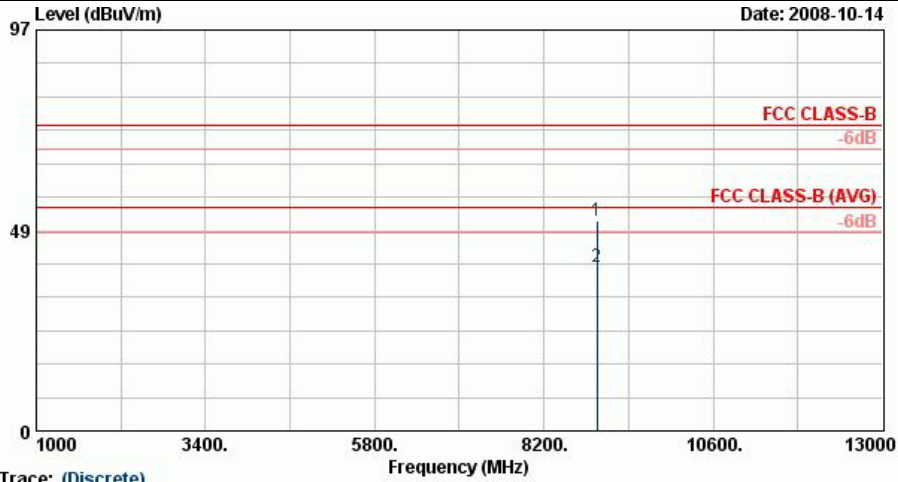

Trace: (Discrete)
 Site : 03CH06-HY
 Condition : FCC CLASS-B 3m HF-ANT(8-16)-060018 VERTICAL
 Power : From System
 Model : FD 892435
 Name : Mode 4

	Freq	Level	Over Limit	Limit Line	ReadAntenna Level	Antenna Factor	Cable Loss	Preamp Factor	Ant Pos	Table Pos	Remark
	MHz	dBuV/m	dB	dBuV/m	dBuV	dB/m	dB	dB	cm	deg	
1	8948.00	50.84	-23.16	74.00	43.52	36.15	7.74	36.57	100	0	Peak
2	8948.00	39.49	-14.51	54.00	32.17	36.15	7.74	36.57	100	304	Average



4. List of Measuring Equipments

Instrument	Manufacturer	Model No.	Serial No.	Characteristics	Calibration Date	Due Date	Remark
EMI Receiver	R&S	ESCS 30	100356	9kHz – 2.75GHz	Aug. 01, 2008	Jul. 31, 2009	Conduction (CO05-HY)
Two-LISN	R&S	ENV216	11-100081	9kHz – 30MHz	Dec. 06, 2007	Dec. 05, 2008	Conduction (CO05-HY)
Two-LISN	R&S	ENV216	11-100080	9kHz – 30MHz	Dec. 06, 2007	Dec. 05, 2008	Conduction (CO05-HY)
DC- LISN	R&S	ESH3-26	1000485	0.1MHz-200MHz	Feb. 04, 2008	Feb. 03, 2009	Conduction (CO05-HY)
DC- LISN	R&S	ESH3-26	1000484	0.1MHz-200MHz	Feb. 04, 2008	Feb. 03, 2009	Conduction (CO05-HY)
Bilog Antenna	SCHAFFNER	CBL6111C	2726	30MHz-1GHz	Dec. 01, 2007	Nov. 30, 2008	Radiation (03CH07-HY)
Spectrum Analyzer	R&S	FSP	101067	9KHz~30GHz	Dec. 05, 2007	Dec. 04, 2008	Radiation (03CH07-HY)
Double Ridge Horn Antenna	ESCO	3117	75962	1G~18GHz	Aug. 13, 2008	Aug. 12, 2009	Radiation (03CH07-HY)
PreAmplifier	Agilent	8449B	3008A02362	1~26.5GHz	Dec. 22, 2007	Dec. 21, 2008	Radiation (03CH07-HY)
PreAmplifier	COM-POWER	PA-103A	161241	10-1000MHz. 32dB.GAIN	Mar. 31, 2008	Mar. 30, 2009	Radiation (03CH07-HY)
Double Ridge Horn Antenna	ESCO	3117	66584	1G~18GHz	Aug. 06, 2008	Aug. 05, 2009	Radiation (03CH07-HY)
Base Station Simulator	R&S	CMU200	103937	N/A	Oct. 19, 2007	Oct. 18, 2008	Radiation (03CH07-HY)

5. Uncertainty of Evaluation

Uncertainty of Conducted Emission Measurement (150 KHz ~ 30 MHz)

Contribution	Uncertainty of x_i		$u(x_i)$
	dB	Probability Distribution	
Receiver reading	0.10	Normal(k=2)	0.05
Cable loss	0.10	Normal(k=2)	0.05
AMN insertion loss	2.50	Rectangular	0.63
Receiver Spec	1.50	Rectangular	0.43
Site imperfection	1.39	Rectangular	0.80
Mismatch	+0.34/-0.35	U-shape	0.24
Combined standard uncertainty Uc(y)	1.13		
Measuring uncertainty for a level of confidence of 95% U=2Uc(y)	2.26		

Uncertainty of Radiated Emission Measurement (30 MHz ~ 1000 MHz)

Contribution	Uncertainty of x_i		$u(x_i)$
	dB	Probability Distribution	
Receiver reading	0.41	Normal(k=2)	0.21
Antenna factor calibration	0.83	Normal(k=2)	0.42
Cable loss calibration	0.25	Normal(k=2)	0.13
Pre Amplifier Gain calibration	0.27	Normal(k=2)	0.14
RCV/SPA specification	2.50	Rectangular	0.72
Antenna Factor Interpolation for Frequency	1.00	Rectangular	0.29
Site imperfection	1.43	Rectangular	0.83
Mismatch	+0.39/-0.41	U-shaped	0.28
Combined standard uncertainty Uc(y)	1.27		
Measuring uncertainty for a level of confidence of 95% U=2Uc(y)	2.54		



Uncertainty of Radiated Emission Measurement (1 GHz ~ 40 GHz)

Contribution	Uncertainty of x_i		$u(x_i)$	C_i	$C_i * u(x_i)$
	dB	Probability Distribution			
Receiver reading	±0.10	Normal(k=1)	0.10	1	0.10
Antenna factor calibration	±1.70	Normal(k=2)	0.85	1	0.85
Cable loss calibration	±0.50	Normal(k=2)	0.25	1	0.25
Receiver Correction	±2.00	Rectangular	1.15	1	1.15
Antenna Factor Directional	±1.50	Rectangular	0.87	1	0.87
Site imperfection	±2.80	Triangular	1.14	1	1.14
Mismatch Receiver VSWR $\Gamma_1 = 0.197$ Antenna VSWR $\Gamma_2 = 0.194$ Uncertainty = $20 \log(1 - \Gamma_1 * \Gamma_2)$	+0.34/-0.35	U-shaped	0.244	1	0.244
Combined standard uncertainty Uc(y)	2.36				
Measuring uncertainty for a level of confidence of 95% U=2Uc(y)	4.72				

6. Certification of NVLAP Accreditation

United States Department of Commerce
National Institute of Standards and Technology

NVLAP[®]

Certificate of Accreditation to ISO/IEC 17025:2005

NVLAP LAB CODE: 200079-0

Sporton International, Inc. Hwa Ya EMC Laboratory
Tao Yuan Hsien 333
TAIWAN

*is accredited by the National Voluntary Laboratory Accreditation Program for specific services,
listed on the Scope of Accreditation, for:*

ELECTROMAGNETIC COMPATIBILITY AND TELECOMMUNICATIONS

*This laboratory is accredited in accordance with the recognized International Standard ISO/IEC 17025:2005.
This accreditation demonstrates technical competence for a defined scope and the operation of a laboratory quality
management system (refer to joint ISO-ILAC-IAF Communique dated 18 June 2005).*

2008-01-01 through 2008-12-31
Effective dates



Sally S. Bruce
For the National Institute of Standards and Technology

NVLAP-01C (REV. 2006-09-13)



Appendix A. Photographs of EUT

Please refer to Sporton report number EP892435 as below.