

FCC Information

This device complies with Part 15 of the FCC rules. Operation is subject to the following two conditions: (1) this device may not cause harmful interference, and (2) this device must accept any interference received, including interference that may cause undesired operation.

NOTE: This equipment has been tested and found to comply with the limits for a Class B digital device, pursuant to Part 15 of the FCC rules. These limits are designed to provide reasonable protection against harmful interference in a residential installation. This equipment generates, uses, and can radiate radio frequency energy and, if not installed and used in accordance with the instructions, may cause harmful interference to radio communications. However, there is no guarantee that interference will not occur in a particular installation. If this equipment does cause harmful interference to radio or television reception, which can be determined by turning the equipment off and on, the user is encouraged to try to correct the interference by one or more of the following measures:

- Reorient or relocate the receiving antenna.
- Increase the separation between the equipment and receiver.
- Connect the equipment into an outlet on a circuit different from that to which the receiver is connected.
- Consult the dealer or an experienced radio/TV technician for help.

WARNING: Changes or modifications to this unit not expressly approved by the party responsible for compliance could void the user's authority to operate the equipment. CAN ICES-3 (B)/NMB-3(B)

Replacement of any transmitter component (crystal, semiconductor, etc.) not authorized by the IC/FCC equipment authorization for this radio could violate IC/FCC rules.

Portable Radio Operation and RF Exposure

This equipment complies with FCC radiation exposure limits set forth for an uncontrolled environment. This transmitter must not be co-located or operating in conjunction with any other antenna or transmitter.

Limited One-Year Warranty

eKids, LLC warrants this product to be free from defects in workmanship and materials, under normal use and conditions, for a period of one (1) year from the date of original purchase.

Should this product fail to function in a satisfactory manner, it is best to first return it to the store where it was originally purchased. Should this fail to resolve the matter and service still be required by reason of any defect or malfunction during the warranty period, eKids will repair or, at its discretion, replace this product without charge. This decision is subject to verification of the defect or malfunction upon delivery of this product to the Factory Service Center authorized by Customer Service.

If service is required, please call Customer Service at 1-888-TOP-TOYS to obtain a Return Authorization Number and shipping instructions. A copy of the sales receipt is required to validate in-warranty coverage.

Disclaimer of Warranty

NOTE: This warranty is valid only if the product is used for the purpose for which it was designed. It does not cover (i) products which have been damaged by negligence or willful actions, misuse or accident, or which have been modified or repaired by unauthorized persons; (ii) cracked or broken cabinets, or units damaged by excessive heat; (iii) damage to digital media players, CD's or tape cassettes (if applicable); (iv) the cost of shipping this product to the Factory Service Center and its return to the owner.

This warranty is valid only in the United States of America and does not extend to owners of the product other than to the original purchaser. In no event will eKids or any of its affiliates, contractors, resellers, their officers, directors, shareholders, members or agents be liable to you or any third party for any consequential or incidental damages, any lost profits, actual, exemplary or punitive damages. (Some states do not allow limitations on implied warranties or exclusion of consequential damages, so these restrictions may not apply to you.) This warranty gives you specific legal rights, and you may also have other rights which vary from state to state.

Your acknowledgement and agreement to fully and completely abide by the above mentioned disclaimer of warranty is contractually binding to you upon your transfer of currency (money order, cashier's check, or credit card) for purchase of your eKids product.

© 2018 eKids, LLC
Questions? Visit www.ekids.com
or call 1-888-TOP-TOYS
1299 Main Street Rahway NJ 07065

© MARVEL



Important Message to Customers

Thank you for purchasing one of our top-quality electronic products. Please take a moment to read through these instructions to help you understand the safe and proper way to use this toy to extend its usability.

Keep these instructions for future reference as they contain important information.

Getting Started

Installing the Batteries

Note: Batteries should always be installed by an adult.

- 1 Use a Phillips screwdriver to open the battery compartment door located on the back of the unit.
- 2 Insert 3 AAA (R03) batteries into each Walkie Talkie with + and - terminals as indicated in the compartment.
- 3 Replace the compartment door and tighten the screw with a Phillips screwdriver. Do not over-tighten the screw.
- 4 One or more Walkie Talkies include 3 LR44 button cell batteries for in-store demonstration purposes only. Remove these batteries before use.

For the Best Possible Performance

- We recommend the use of alkaline batteries for longer life.
- Do not mix old and new batteries.
- Do not mix alkaline, standard (carbon-zinc) or rechargeable (nickel-cadmium) batteries.
- Batteries are to be inserted with correct polarity.
- Remove exhausted batteries from the unit.
- Do not attempt to recharge non-rechargeable batteries.
- Remove the rechargeable batteries from the unit before charging.
- The supply terminals are not to be short-circuited.
- Batteries should be removed if the item will not be used for an extended period of time, such as a month or longer, to prevent battery leakage or damage.
- Rechargeable batteries should only be charged under adult supervision.
- Only batteries of the same or equivalent type as recommended are to be used

Turning Power On/Off

- Slide the **ON/OFF/DEMO Switch** to the ON position to turn the unit on. The Power LED lights up to indicate the unit is ON.
- Both Walkie Talkies must be turned on in order to send and receive messages.
- Slide the **ON/OFF/DEMO Switch** to the OFF position to turn off the unit. The Power LED light will disappear.

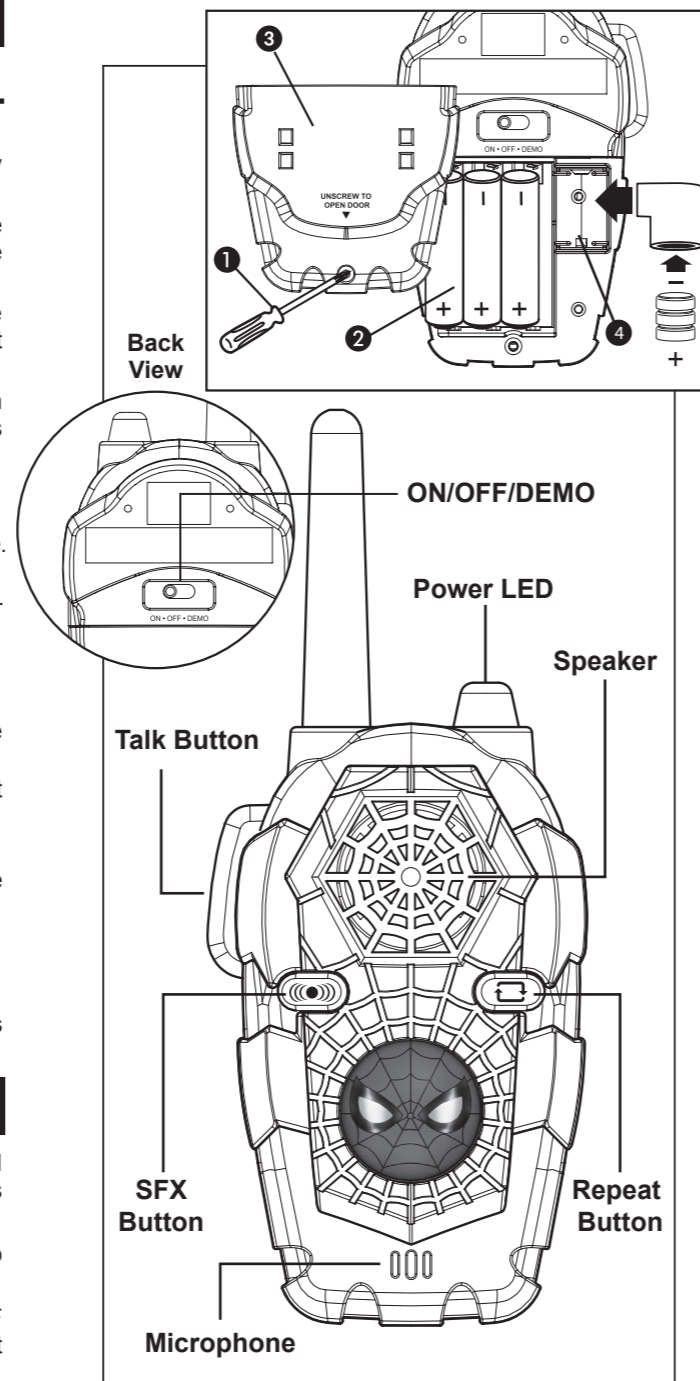

Speaking

Press and hold the **Talk Button** while speaking into the Microphone. Release the **Talk Button** to listen.

You Should Know

For clear transmission, keep the antenna pointing upwards and the microphone approximately two inches from your mouth.

Listening

- Both Walkie Talkies must be turned on and have their antennas pointing upwards in order to send and receive messages (speak and listen).
- Messages cannot be received while the **Talk Button** is being pressed. Release the **Talk Button** to listen.
- Messages can be heard through the Speaker.

Playing Walkie Talkie Games

Walkie Talkies can be used for all kinds of fun games and activities. Here are two suggestions:

Hide and Seek

Just like regular Hide and Seek, but with a twist: the "Hider" can send clues to the "Seeker" using the Walkie Talkies.

Mystery Sounds

Can you recognize the mystery sound? One kid sends a sound over the Walkie Talkies, while another tries to guess what the sound is. Examples can include an animal, song, TV show, or anything else!

Sound Effects

- Press the SFX Button to hear speech and sound effects!
- Press the Repeat Button to replay the sound effects.
- Hold down the Talk Button while pressing either the SFX Button or the Repeat Button to send sound effects to the other Walkie Talkie!

Questions or Comments

It is important to keep the Walkie Talkies as dry and clean as possible. You may clean the cabinet with a cloth or sponge moistened with mild soap and water. Do not attempt to use strong cleansers or solvents, as they may cause damage.

Maintenance

- For questions or comments regarding this or other eKids products, please call our toll-free number: **1-888-TOP-TOYS**

Also visit our website: www.ekids.com

If problems persist, please do not attempt to repair unit; see warranty for factory service.

Troubleshooting

If you experience any of the following problems please insert 3 fresh new AAA (R03) batteries into each unit.

1. If one or both of the Walkie Talkies do not work, this may indicate that the batteries are weak.
2. If the signal range of the Walkie Talkies decreases notably, this may indicate that the batteries are weak.

Please keep in mind that this product does not transmit well through obstacles such as trees, buildings, and metal structures.

If there is a sizable increase in static, it may be due to the proximity of electric motors, fluorescent lights, power lines, or other signal-disrupting objects. You may have to change your location.

If problems persist, DO NOT ATTEMPT TO REPAIR THE UNIT. See the Warranty for factory services.