

# FCC Test Report

**Report No.:** 2405W23590EC

**Applicant:** Kiddesigns Inc

**Address:** 1299 Main Street, Rahway New Jersey, United States, 07065-0901

**Product Name:** XX-207 Walkie talkies

**Product Model:** BU-207.EXv24

**Multiple Models:** BU-207.EXv25TG, BU-207.FXv25TG, SA-207.EXv24

**Trade Mark:** eKids

**FCC ID:** IAJ202C8C

**Standards:** FCC CFR Title 47 Part 95B

**Test Date:** 2024-09-05 to 2024-10-21

**Test Result:** Complied

**Issue Date:** 2024-10-21

**Reviewed by:**

*Frank Yin*

**Approved by:**

*Jacob Kong*

Frank Yin

Project Engineer

Jacob Kong

Manager

**Prepared by:**

World Alliance Testing & Certification (Shenzhen) Co., Ltd

No. 1002, East Block, Laobing Building, Xingye Road 3012, Xixiang street, Bao'an District, Shenzhen,  
Guangdong, People's Republic of China



This report may contain data that are not covered by the NVLAP accreditation and shall be marked with an asterisk “★”

## Announcement

1. This test report shall not be reproduced except in full, without the written approval of World Alliance Testing & Certification (Shenzhen) Co., Ltd
2. The results in this report apply only to the sample tested.
3. This sample tested is in compliance with the limits of the above regulation.
4. This report must not be used by the client to claim product certification, approval, or endorsement by NVLAP, NIST, or any agency of the U.S. Government.
5. The information marked “#” is provided by the applicant, the laboratory is not responsible for its authenticity and this information can affect the validity of the result in the test report. Customer model name, addresses, names, trademarks etc. are included.

## Revision History

Version No.	Issued Date	Description
00	2024-10-21	Original

# Contents

<b>1</b>	<b>General Information .....</b>	<b>4</b>
1.1	Client Information .....	4
1.2	Product Description of EUT .....	4
1.3	Measurement Uncertainty .....	5
1.4	Laboratory Location .....	5
1.5	Test Methodology .....	5
<b>2</b>	<b>Description of Measurement .....</b>	<b>6</b>
2.1	Test Configuration .....	6
2.2	Test Auxiliary Equipment .....	6
2.3	Interconnecting Cables .....	6
2.4	Block Diagram of Connection between EUT and AE .....	6
2.5	Test Setup .....	7
2.6	Test Procedure .....	8
2.7	Measurement Method .....	9
2.8	Measurement Equipment .....	10
<b>3</b>	<b>Test Results .....</b>	<b>11</b>
3.1	Test Summary .....	11
3.2	Limit .....	12
3.3	Radiated Test Data .....	13
3.3.1	effective radiated power (e.r.p.) .....	13
3.3.2	Radiated Unwanted Emissions .....	14
3.4	RF Conducted Test Data .....	16
3.4.1	MODULATION LIMITING .....	16
3.4.2	Audio Frequency Response .....	17
3.4.3	Authorized Bandwidth and Emission Mask .....	19
3.4.4	Frequency stability .....	20
<b>4</b>	<b>FCC §95.587 FRS Additional Requirements .....</b>	<b>21</b>
<b>5</b>	<b>Test Setup Photo .....</b>	<b>22</b>
<b>6</b>	<b>E.U.T Photo .....</b>	<b>23</b>

# 1 General Information

## 1.1 Client Information

Applicant:	Kiddesigns Inc
Address:	1299 Main Street, Rahway New Jersey,United States,07065-0901
Manufacturer:	Kiddesigns Inc
Address:	1299 Main Street, Rahway New Jersey,United States,07065-0901

## 1.2 Product Description of EUT

The EUT is XX-207 Walkie talkies that contains FRS radio, this report covers the full testing of the FRS radio.

Sample Serial number	BU-207.EXv24: 2QQ3-1, SA-207.EXv24: 2QQ3-3 for RE 2QQ3-2 for RF conducted test (assigned by WATC)
Sample Received Date	2024-09-03
Sample Status	Good Condition
Frequency Range	467.5625MHz
Maximum ERP	1.80dBm
Modulation Technology	FM
Emission Type	F3E
Spatial Streams	1TX1RX
Antenna Type	Integral
Antenna Gain <sup>#</sup>	0dBi
Power Supply	DC 3V from battery
Adapter Information	N/A
Modification	Sample No Modification by the test lab

### 1.3 Measurement Uncertainty

Parameter		Expanded Uncertainty (Confidence of 95%(U = 2Uc(y)))
AC Power Lines Conducted Emissions		±3.14dB
Emissions, Radiated	Below 30MHz	±2.78dB
	Below 1GHz	±4.84dB
	Above 1GHz	±5.44dB
Emissions, Conducted		1.75dB
Conducted Power		0.74dB
Frequency Error		150Hz
Bandwidth		0.34%
Modulation Limiting		1.32%
<p><b>Note 1:</b> The extended uncertainty given in this report is obtained by combining the standard uncertainty times the coverage factor K with the 95% confidence interval. Otherwise required by the applicant or Product Regulations, Decision Rule in this report did not consider the uncertainty.</p> <p><b>Note 2:</b> The Decision Rule is based on simple acceptance with ISO Guide 98-4:2012 Clause 8.2 (Measurement uncertainty is not taken into account when stating conformity with a specified requirement.)</p>		

### 1.4 Laboratory Location

World Alliance Testing & Certification (Shenzhen) Co., Ltd

No. 1002, East Block, Laobing Building, Xingye Road 3012, Xixiang street, Bao'an District, Shenzhen, Guangdong, People's Republic of China

Tel: +86-755-29691511, Email: [qa@watc.com.cn](mailto:qa@watc.com.cn)

The lab has been recognized as the FCC accredited lab under the KDB 974614 D01 and is listed in the FCC Public Access Link (PAL) database, FCC Registration No. : 463912, the FCC Designation No. : CN5040.

The lab has been recognized by Innovation, Science and Economic Development Canada to test to Canadian radio equipment requirements, the CAB identifier: CN0160.

### 1.5 Test Methodology

FCC CFR Title 47 Part 2, 95B

ANSI C63.26-2015

## 2 Description of Measurement

### 2.1 Test Configuration

Operating channels:					
Channel No.	Frequency (MHz)	Channel No.	Frequency (MHz)	Channel No.	Frequency (MHz)
1	467.5625	/	/	/	/
According to Per C63.26-2015, section 5.1, Channel 1 was selected to test					

Test Mode:	
Transmitting mode:	Keep the EUT in continuous transmitting with modulation

Worst-Case Configuration:
<p>The applicant declared that EUT Models BU-207.EXv24, BU-207.EXv25TG, BU-207.FXv25TG, SA-207.EXv24 were electrical identical, they are only difference for model number and exterior appearance, detail please refer the EUT photo and DOS letter provided by applicant. The shell material of all models are plastic, it's not affect the RF/EMC performance, so only model BU-207.EXv24 was selected to full test; for model SA-207.EXv24, as it's internal structure is little difference to other models, so model SA-207.EXv24 was additional checked radiated measurement.</p> <p>For radiated emissions, EUT was investigated in three orthogonal orientation, the worst-case orientation was recorded in report</p> <p>For radiated emission was investigated from 30MHz to 10 times of fundamental with the EUT transmits at the highest output power as worst-case scenario.</p>

### 2.2 Test Auxiliary Equipment

Manufacturer	Description	Model	Serial Number
/	/	/	/

### 2.3 Interconnecting Cables

Manufacturer	Description	Length(m)	From	To
/	/	/	/	/

### 2.4 Block Diagram of Connection between EUT and AE

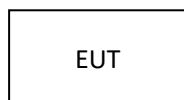

Note: for reference only, the actual connection setup used for testing please refer to the test photos.

## 2.5 Test Setup

### 1) Radiated emission measurement:

30MHz-1GHz (3m SAC)

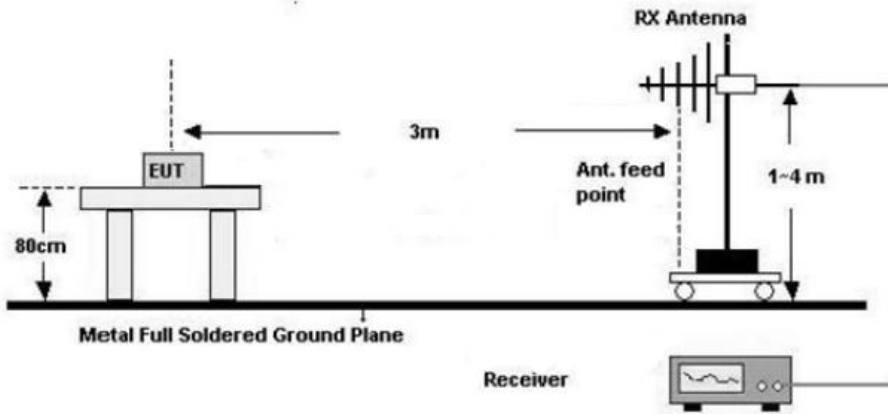

1GHz-5GHz(3m FAC)

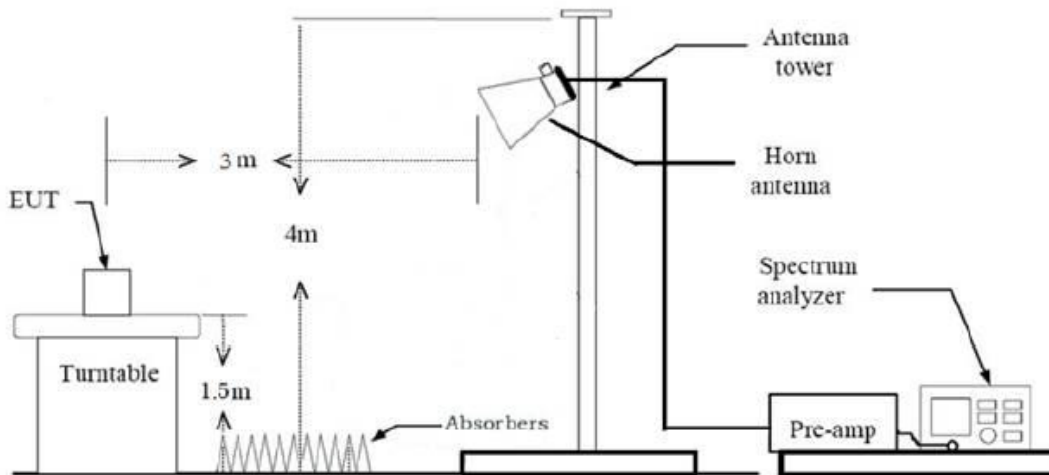

### 2) RF Conducted Test

For Modulation Limiting/Audio Frequency Response test

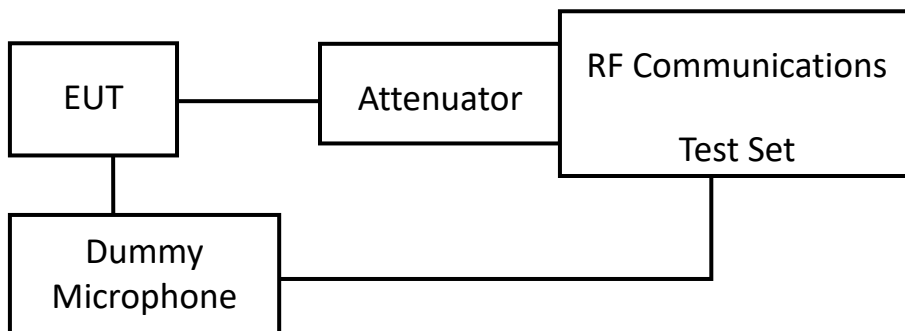

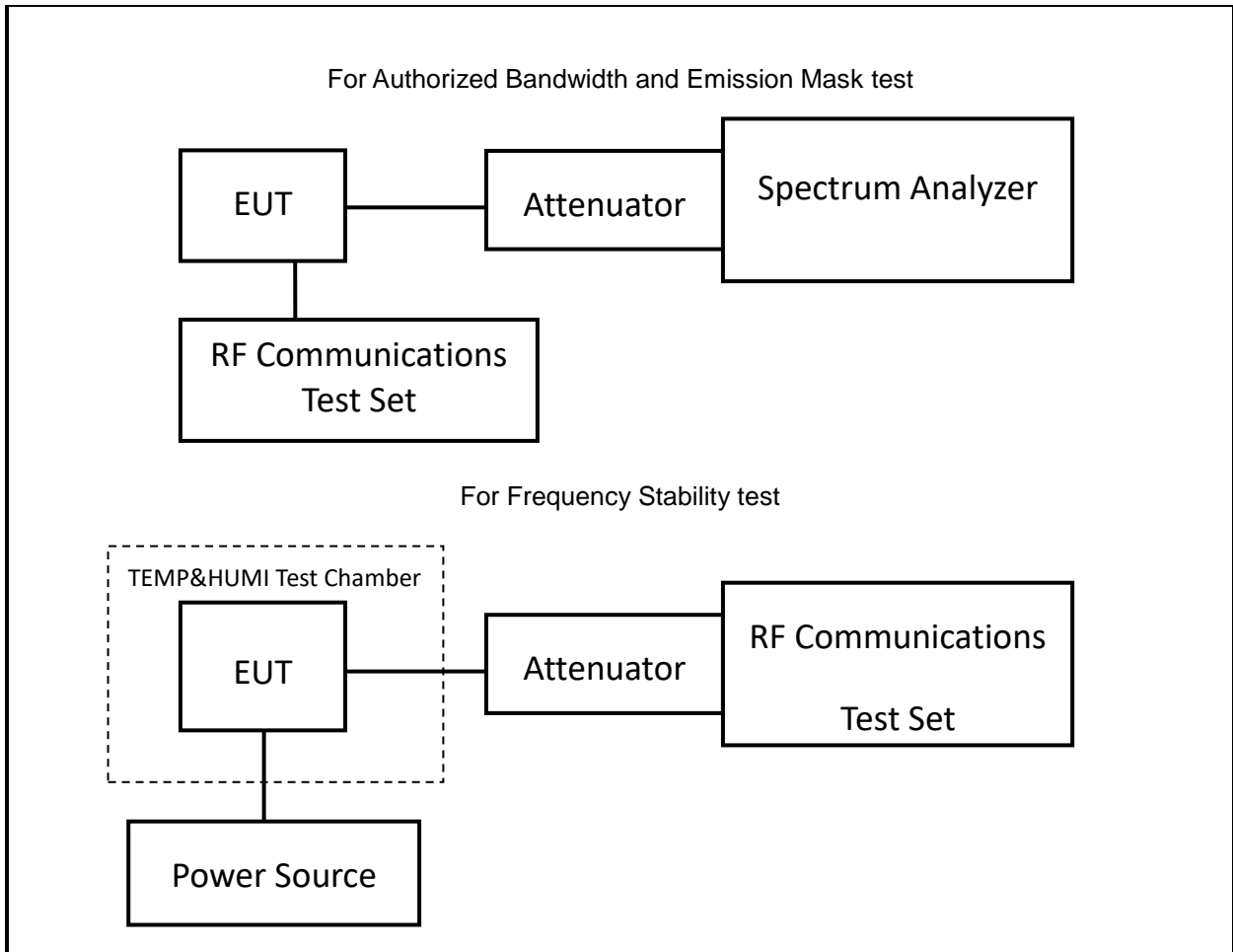

## 2.6 Test Procedure

### Radiated Emission Procedure:

#### a) For 30MHz-1GHz:

1. The EUT was placed on the tabletop of a rotating table 0.8 m the ground at a 3 m semi anechoic chamber. The measurement distance from the EUT to the receiving antenna is 3 m.
2. EUT works in each mode of operation that needs to be tested. The highest signal levels relative to the limit shall be determined by rotating the EUT from 0° to 360° and with varying the measurement antenna height between 1 m and 4 m in vertical and horizontal polarizations.

#### b) For above 1GHz:

1. The EUT was placed on the tabletop of a rotating table 1.5 m the ground at a 3 m fully anechoic room. The measurement distance from the EUT to the receiving antenna is 3 m.
2. EUT works in each mode of operation that needs to be tested, and having the EUT continuously working. The highest signal levels relative to the limit shall be determined by rotating the EUT from 0° to 360° and with varying the measurement antenna height between 1 m and 4 m in vertical and horizontal polarizations.
3. Open the test software to control the test antenna and test turntable. Perform the test, save the test results, and export the test data.



**RF Conducted Test:**

1. The antenna port of EUT was connected to the RF port of the test equipment (RF Communications Test Set or Spectrum analyzer) through Attenuator and RF cable.
2. The cable assembly insertion loss of 7.0dB (including 6.0 dB Attenuator and 1.0 dB cable) was entered as an offset in the spectrum analyzer. Note: Actual cable loss was unavailable at the time of testing, therefore a loss of 1.0dB was assumed as worst case. This was later verified to be true by laboratory. ( if the RF cable provided by client, the cable loss declared by client)
3. The EUT is keeping in continuous transmission mode with modulation signals required.

**2.7 Measurement Method**

Description of Test	Measurement Method
Modulation Limiting	ANSI C63.26-2015 section 5.3.2
Audio Frequency Response	ANSI C63.26-2015 section 5.3.3.2
Authorized Bandwidth	ANSI C63.26-2015 section 5.4.4
Transmitter output power and effective radiated power (e.r.p.)	ANSI C63.26-2015 section 5.2.3.3&5.2.5.5 or ANSI C63.26-2015 section 5.5.4
Emission Mask	ANSI C63.26-2015 section 5.7.3
Frequency Stability	ANSI C63.26-2015 section 5.6
Radiated Unwanted Emissions	ANSI C63.26-2015 section 5.5.4

## 2.8 Measurement Equipment

Manufacturer	Description	Model	Management No.	Calibration Date	Calibration Due Date
<b>Radiated Emission Test</b>					
R&S	EMI test receiver	ESR3	102758	2024/6/4	2025/6/3
ROHDE& SCHWARZ	SPECTRUM ANALYZER	FSV40-N	101608	2024/6/4	2025/6/3
SONOMA INSTRUMENT	Low frequency amplifier	310	186014	2024/6/4	2025/6/3
COM-POWER	preamplifier	PAM-118A	18040152	2024/6/4	2025/6/3
SCHWARZBECK	Log - periodic wideband antenna	VULB 9163	9163-872	2023/7/7	2026/7/6
Astro Antenna Ltd	Horn antenna	AHA-118S	3015	2023/7/6	2026/7/5
N/A	Coaxial Cable	NO.9	N/A	2024/6/4	2025/6/3
N/A	Coaxial Cable	NO.14	N/A	2024/6/4	2025/6/3
N/A	Coaxial Cable	NO.15	N/A	2024/6/4	2025/6/3
N/A	Coaxial Cable	NO.16	N/A	2024/6/4	2025/6/3
N/A	Coaxial Cable	NO.17	N/A	2024/6/4	2025/6/3
Audix	Test Software	E3	191218 V9	/	/
<b>RF Conducted Test</b>					
ROHDE& SCHWARZ	SPECTRUM ANALYZER	FSV40	101419	2024/6/4	2025/6/3
MEEA	6dB attenuator	603-06-1	N/A	2024/6/4	2025/6/3
HP	RF communication test set	HP8920A	T-01-EM046	2024/1/16	2025/1/15
BACL	TEMP&HUMI Test Chamber	BTH-150	30022	2024/7/11	2025/7/10
FLUKE	Digital Multimeter	15B+	N/A	2024/6/6	2025/6/5
UNI-T	DC Power Supply	UTP1310S	C221286498	NCR	NCR

Note: All equipment is calibrated with valid calibrations. Each measurement data is traceable to the national or International standards.

### 3 Test Results

#### 3.1 Test Summary

FCC Rules	Description of Test	Result
§2.1055(d), §95.565	FRS Frequency Accuracy	Compliance
§2.1046, §95.567	FRS transmit Power	Compliance
§95.571	FRS Emission Types	Compliance
§2.1049, §95.573	FRS Authorized Bandwidth	Compliance
§95.579	Emission Mask	Compliance
§2.1047, §95.575	FRS Modulation Limits	Compliance
§2.1053, §95.579	FRS Unwanted Emissions Limits	Compliance
§95.587	FRS Additional Requirements	Compliance

### 3.2 Limit

Test items	Limit
FRS Frequency Accuracy	Each FRS transmitter type must be designed such that the carrier frequencies remain within $\pm 2.5$ parts-per-million of the channel center frequencies specified in § 95.563 during normal operating conditions.
FRS transmit Power	Each FRS transmitter type must be designed such that the effective radiated power (ERP) on channels 8 through 14 does not exceed 0.5 Watts and the ERP on channels 1 through 7 and 15 through 22 does not exceed 2.0 Watts.
FRS Emission Types	Each FRS transmitter type must be designed such that it can transmit only the following emission types: F3E, G3E, F2D, and G2D.
FRS Authorized Bandwidth	Each FRS transmitter type must be designed such that the occupied bandwidth does not exceed 12.5 kHz.
FRS Modulation Limits	Each FRS transmitter type must be designed such that the peak frequency deviation does not exceed 2.5 kHz, and the highest audio frequency contributing substantially to modulation must not exceed 3.125 kHz.
FRS Unwanted Emissions Limits	<p>Each FRS transmitter type must be designed to satisfy the applicable unwanted emissions limits in this paragraph.</p> <p>(a) Attenuation requirements. The power of unwanted emissions must be attenuated below the carrier power output in Watts (P) by at least:</p> <p>(1) 25 dB (decibels) in the frequency band 6.25 kHz to 12.5 kHz removed from the channel center frequency.</p> <p>(2) 35 dB in the frequency band 12.5 kHz to 31.25 kHz removed from the channel center frequency.</p> <p>(3) <math>43 + 10 \log (P)</math> dB in any frequency band removed from the channel center frequency by more than 31.25 kHz.</p> <p>(b) Measurement bandwidths. The power of unwanted emissions in the frequency bands specified in paragraphs (a)(1) and (2) of this section is measured with a reference bandwidth of 300 Hz. The power of unwanted emissions in the frequency range specified in paragraph (a)(3) is measured with a reference bandwidth of at least 30 kHz.</p> <p>(c) Measurement conditions. The requirements in this section apply to each FRS transmitter type both with and without the connection of permitted attachments, such as an external speaker, microphone and/or power cord.</p>

### 3.3 Radiated Test Data

<b>Test Date:</b>	2024-09-05~2024-10-21	<b>Test By:</b>	Luke Li
<b>Environment condition:</b>	Temperature: 21.4~25.4°C; Relative Humidity:60~65%; ATM Pressure: 99.2~101kPa		

#### 3.3.1 effective radiated power (e.r.p.)

Model: BU-207.EXv24

Frequency (MHz)	Reading level (dBμV)	Polar (H/V)	Corrected Factor (dB/m)	Corrected Amplitude (dBμV/m)	EIRP CF	ERP (dBm)	Limit (dBm)	Margin (dB)	Remark
467.5625MHz									
467.5625	67.23	horizontal	23.55	90.78	95.20	-6.57	27.00	-33.57	Peak
467.5625	74.77	vertical	23.55	98.32	95.20	0.97	27.00	-26.03	Peak

Model: SA-207.EXv24

Frequency (MHz)	Reading level (dBμV)	Polar (H/V)	Corrected Factor (dB/m)	Corrected Amplitude (dBμV/m)	EIRP CF	ERP (dBm)	Limit (dBm)	Margin (dB)	Remark
467.5625MHz									
467.5625	66.35	horizontal	23.55	89.90	95.20	-7.45	27.00	-34.45	Peak
467.5625	75.60	vertical	23.55	99.15	95.20	1.80	27.00	-25.20	Peak

Remark:

Corrected Amplitude= Reading level + corrected Factor

Corrected Factor = Antenna factor + Cable loss – Amplifier gain

Margin = ERP – Limit

According to ANSI C63.26-2015 section 5.2.7:

$EIRP (dBm) = E (dB\mu V/m) + 20\log(D) - 104.8$ ; where D is the measurement distance (in the far field region) in m.

Test was performed on 3meters distance, so

$EIRP = Corrected\ Amplitude + 20\log(3) - 104.8$   
= Corrected Amplitude - 95.2

According to ANSI C63.26-2015 Annex C, C.4 :

$ERP = EIRP - 2.15\ dB$

So  $ERP = Corrected\ Amplitude - 95.2 - 2.15$

### 3.3.2 Radiated Unwanted Emissions

Model: BU-207.EXv24

Frequency (MHz)	Reading level (dB $\mu$ V)	Polar (H/V)	Corrected Factor (dB/m)	Corrected Amplitude (dB $\mu$ V/m)	EIRP CF	Result (dBm)	Limit (dBm)	Margin (dB)	Remark
467.5625MHz									
935.125	16.72	horizontal	29.97	46.69	95.20	-48.51	-13.00	-35.51	Peak
1402.688	74.79	horizontal	-5.65	69.14	95.20	-26.06	-13.00	-13.06	Peak
1870.250	69.15	horizontal	-4.23	64.92	95.20	-30.28	-13.00	-17.28	Peak
2337.813	64.57	horizontal	-3.26	61.31	95.20	-33.89	-13.00	-20.89	Peak
2805.375	59.86	horizontal	-2.65	57.21	95.20	-37.99	-13.00	-24.99	Peak
3272.938	63.44	horizontal	-2.99	60.45	95.20	-34.75	-13.00	-21.75	Peak
3740.500	65.01	horizontal	-2.96	62.05	95.20	-33.15	-13.00	-20.15	Peak
4208.063	66.53	horizontal	-4.17	62.36	95.20	-32.84	-13.00	-19.84	Peak
4675.625	63.90	horizontal	-2.62	61.28	95.20	-33.92	-13.00	-20.92	Peak
935.125	20.24	vertical	29.97	50.21	95.20	-44.99	-13.00	-31.99	Peak
1402.688	74.73	vertical	-5.65	69.08	95.20	-26.12	-13.00	-13.12	Peak
1870.250	71.83	vertical	-4.23	67.6	95.20	-27.60	-13.00	-14.60	Peak
2337.813	69.89	vertical	-3.26	66.63	95.20	-28.57	-13.00	-15.57	Peak
2805.375	62.26	vertical	-2.65	59.61	95.20	-35.59	-13.00	-22.59	Peak
3272.938	65.24	vertical	-2.99	62.25	95.20	-32.95	-13.00	-19.95	Peak
3740.500	62.50	vertical	-2.96	59.54	95.20	-35.66	-13.00	-22.66	Peak
4208.063	61.31	vertical	-4.17	57.14	95.20	-38.06	-13.00	-25.06	Peak
4675.625	56.45	vertical	-2.62	53.83	95.20	-41.37	-13.00	-28.37	Peak

**Model: SA-207.EXv24**

Frequency (MHz)	Reading level (dBμV)	Polar (H/V)	Corrected Factor (dB/m)	Corrected Amplitude (dBμV/m)	EIRP CF	Result (dBm)	Limit (dBm)	Margin (dB)	Remark
467.5625MHz									
935.125	18.99	horizontal	29.97	48.96	95.20	-46.24	-13.00	-33.24	Peak
1402.688	72.08	horizontal	-5.65	66.43	95.20	-28.77	-13.00	-15.77	Peak
1870.250	63.39	horizontal	-4.23	59.16	95.20	-36.04	-13.00	-23.04	Peak
2337.813	71.07	horizontal	-3.26	67.81	95.20	-27.39	-13.00	-14.39	Peak
2805.375	65.77	horizontal	-2.65	63.12	95.20	-32.08	-13.00	-19.08	Peak
3272.938	59.20	horizontal	-2.99	56.21	95.20	-38.99	-13.00	-25.99	Peak
3740.500	57.85	horizontal	-2.96	54.89	95.20	-40.31	-13.00	-27.31	Peak
4208.063	61.11	horizontal	-4.17	56.94	95.20	-38.26	-13.00	-25.26	Peak
4675.625	59.20	horizontal	-2.62	56.58	95.20	-38.62	-13.00	-25.62	Peak
935.125	24.99	vertical	29.97	54.96	95.20	-40.24	-13.00	-27.24	Peak
1402.688	72.97	vertical	-5.65	67.32	95.20	-27.88	-13.00	-14.88	Peak
1870.250	69.09	vertical	-4.23	64.86	95.20	-30.34	-13.00	-17.34	Peak
2337.813	68.11	vertical	-3.26	64.85	95.20	-30.35	-13.00	-17.35	Peak
2805.375	66.61	vertical	-2.65	63.96	95.20	-31.24	-13.00	-18.24	Peak
3272.938	61.54	vertical	-2.99	58.55	95.20	-36.65	-13.00	-23.65	Peak
3740.500	62.45	vertical	-2.96	59.49	95.20	-35.71	-13.00	-22.71	Peak
4208.063	58.33	vertical	-4.17	54.16	95.20	-41.04	-13.00	-28.04	Peak
4675.625	55.43	vertical	-2.62	52.81	95.20	-42.39	-13.00	-29.39	Peak

Remark:

Corrected Amplitude= Reading level + corrected Factor

Corrected Factor = Antenna factor + Cable loss – Amplifier gain

Margin = Result – Limit

According to ANSI C63.26-2015 section 5.2.7:

$EIRP (dBm) = E (dB\mu V/m) + 20\log(D) - 104.8$ ; where D is the measurement distance (in the far field region) in m.

Test was performed on 3meters distance, so

Result = Corrected Amplitude +  $20\log(3) - 104.8$

= Corrected Amplitude - 95.2

The emission levels of other frequencies that were lower than the limit 20dB, not show in test report.

### 3.4 RF Conducted Test Data

<b>Test Date:</b>	2024-09-10~2024-09-11	<b>Test By:</b>	Ryan Zhang
<b>Environment condition:</b>	Temperature: 25.1~25.4°C; Relative Humidity:46~50%; ATM Pressure: 100.5~100.6kPa		

#### 3.4.1 MODULATION LIMITING

Carrier Frequency: 467.5625MHz											
Audio Frequency (Hz)	Deviation (@+0dB) [kHz]		Deviation (@+5dB) [kHz]		Deviation (@+10dB) [kHz]		Deviation (@+15dB) [kHz]		Deviation (@+20dB) [kHz]		Limit [kHz]
	Peak+	Peak-	Peak+	Peak-	Peak+	Peak-	Peak+	Peak-	Peak+	Peak-	
300	0.606	0.609	0.915	0.917	1.452	1.455	1.905	1.906	2.202	2.147	2.500
1000	1.500	1.500	2.056	2.053	2.025	2.003	1.973	1.921	1.903	1.899	2.500
2500	1.967	2.002	1.965	1.979	1.991	1.989	1.990	1.996	2.014	2.005	2.500
3000	1.493	1.480	1.488	1.463	1.502	1.509	1.490	1.479	1.483	1.456	2.500

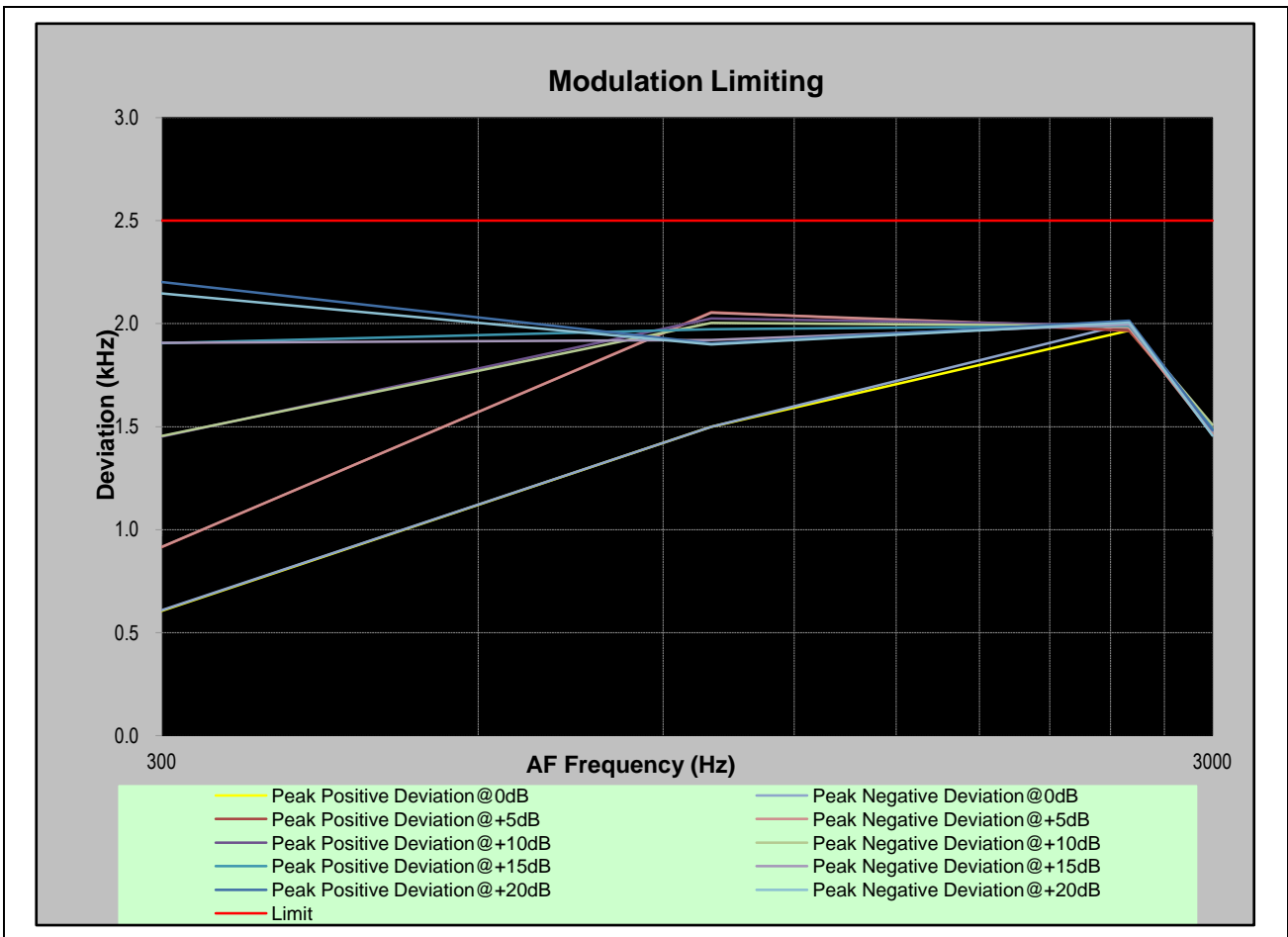



### 3.4.2 Audio Frequency Response

Test Frequency: 467.5625MHz			
Audio Frequency (Hz)	Response Attenuation (dB)	High Limit (dB)	Low Limit (dB)
300	-9.43	-9.4	-17.8
400	-6.94	-6.9	-12.9
500	-5.39	-5.0	-9.0
600	-4.22	-3.4	-7.4
700	-3.04	-2.1	-6.1
800	-1.97	-0.9	-4.9
900	-0.96	0.1	-3.9
1000	0.00	1.0	-3.0
1200	1.62	2.6	-1.4
1400	3.08	3.9	-0.1
1600	4.32	5.1	1.1
1800	5.44	6.1	2.1
2000	6.34	7.0	3.0
2100	6.73	7.4	3.4
2200	7.18	7.8	3.8
2300	7.50	8.2	4.2
2400	7.79	8.6	4.6
2500	8.03	8.9	4.9
2600	8.11	9.3	4.9
2700	8.09	9.6	4.9
2800	7.85	9.9	4.9
2900	7.31	10.2	4.9
3000	6.48	10.5	4.9
3125	5.06	-	-

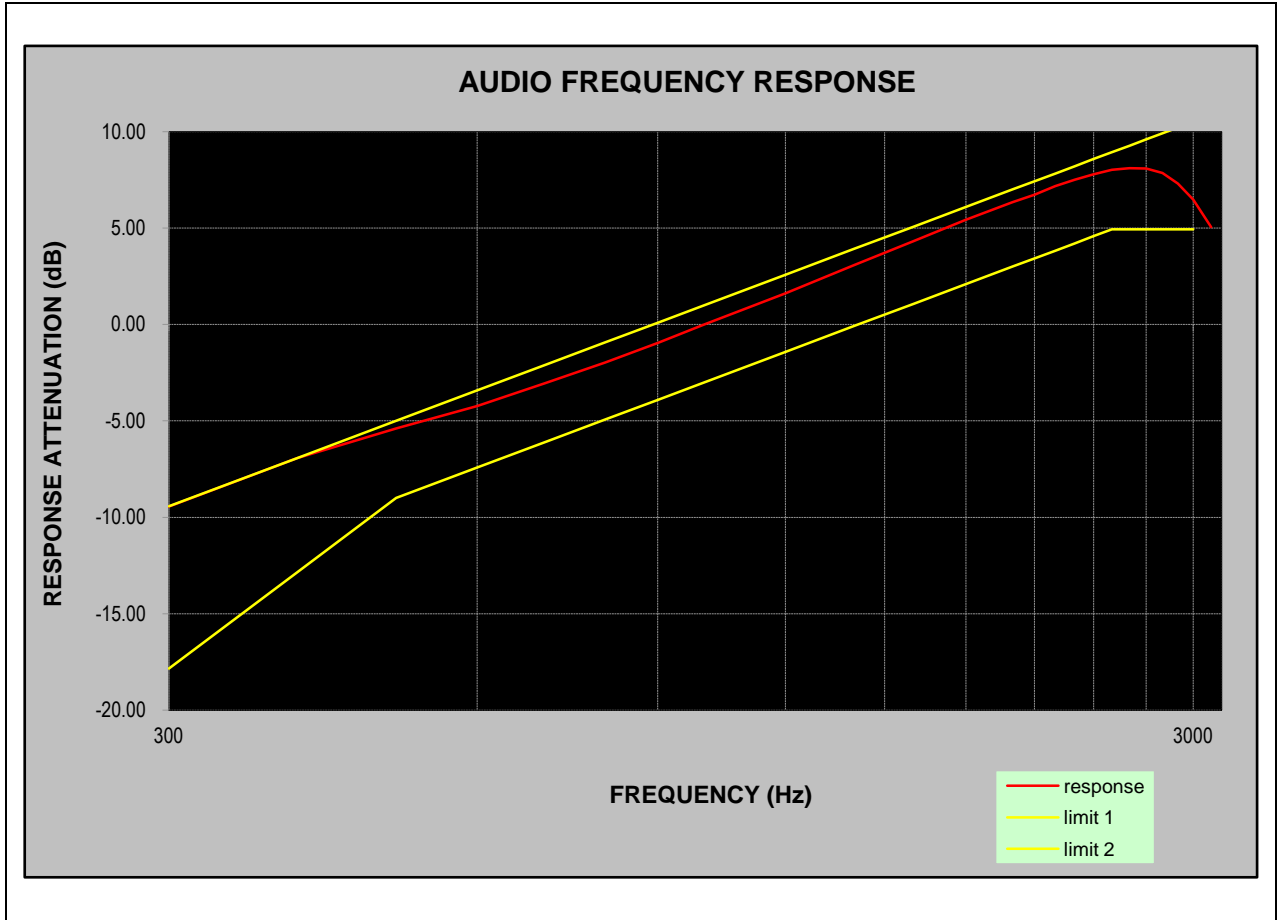

### 3.4.3 Authorized Bandwidth and Emission Mask

Modulation	Frequency (MHz)	OBW (kHz)	Limit (kHz)	Result
FM	467.5625	5.35	12.5	Pass

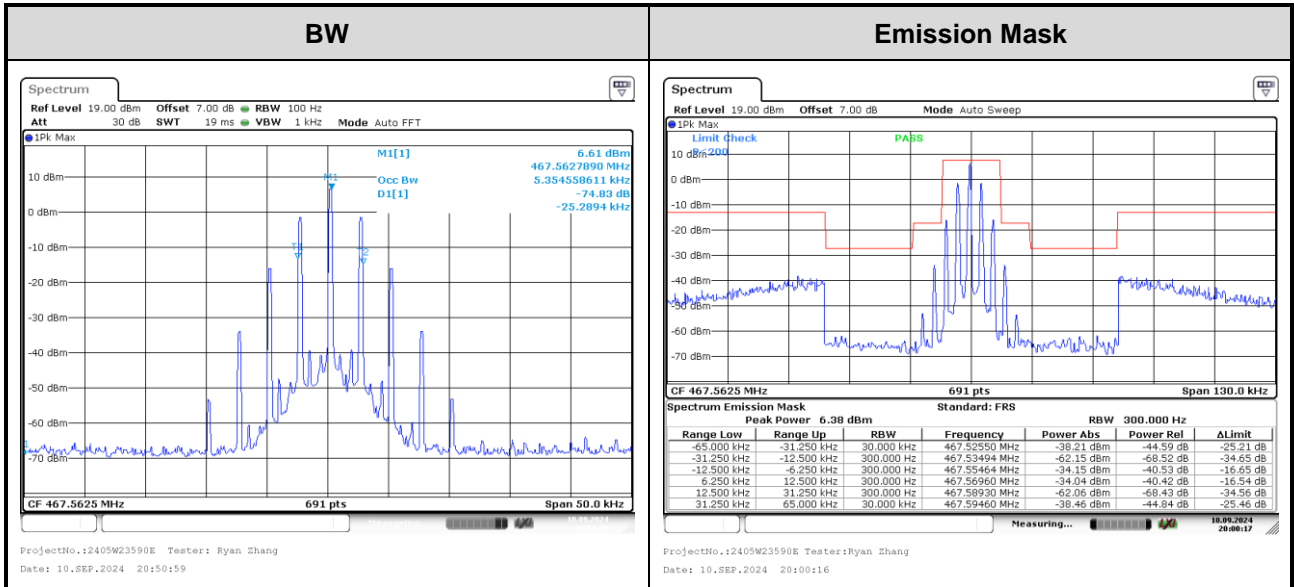

### 3.4.4 Frequency stability

Un-modulation, Reference Frequency: 467.5625MHz						
Test Item	Temperature (°C)	Voltage (Vdc)	Measured Frequency (MHz)	Frequency Error (ppm)	limit (ppm)	Verdict
Frequency Stability vs. Temperature & Voltage	-30	3.0	467.562302	-0.42	≤2.5	Pass
	-20		467.562296	-0.44	≤2.5	Pass
	-10		467.562276	-0.48	≤2.5	Pass
	0		467.562288	-0.45	≤2.5	Pass
	10		467.562299	-0.43	≤2.5	Pass
	20		467.562324	-0.38	≤2.5	Pass
	30		467.562308	-0.41	≤2.5	Pass
	40		467.562312	-0.40	≤2.5	Pass
	50		467.562259	-0.52	≤2.5	Pass
	20	3.45	467.562338	-0.35	≤2.5	Pass
	20	2.55	467.562346	-0.33	≤2.5	Pass

## 4 FCC §95.587 FRS Additional Requirements

Each FRS transmitter type must be designed to meet the following additional requirements.

(a) Transmit frequency capability. FRS transmitter types must not be capable of transmitting on any frequency or channel other than those listed in §95.563.

**Judgment:** Compliance, please refer the operating channels list which provide by applicant record in section 2.1 of report

(b) Antenna. The antenna of each FRS transmitter type must meet the following requirements.

(1) The antenna must be a non-removable integral part of the FRS transmitter type.

(2) The gain of the antenna must not exceed that of a half-wave dipole antenna.

(3) The antenna must be designed such that the electric field of the emitted waves is vertically polarized when the unit is operated in the normal orientation.

**Judgment:** Compliance, please refer section 1.2 of report and EUT photo

(c) Digital data transmissions. FRS transmitter types having the capability to transmit digital data must be designed to meet the following requirements.

(1) FRS units may transmit digital data containing location information, or requesting location information from one or more other FRS or GMRS units, or containing a brief text message to another specific FRS or GMRS unit or units.

(2) Digital data transmissions may be initiated by a manual action or command of the operator or on an automatic or periodic basis, and FRS units may be designed to automatically respond with location data upon receiving an interrogation request from another

(3) Digital data transmissions must not exceed one second in duration.

(4) Digital data transmissions must not be sent more frequently than one digital data transmission within a thirty-second period, except that an FRS unit may automatically respond to more than one interrogation request received within a thirty-second period.

**Judgment:** Not Applicable, no digital modulation function.

(d) Packet mode. FRS transmitter types must not be capable of transmitting data in the store-and-forward packet operation mode.

**Judgment:** Not Applicable, no digital modulation function.

(e) Effective September 30, 2019, no person shall manufacture or import hand-held portable radio equipment capable of operating under this subpart (FRS) and other licensed or licensed-by-rule services in this chapter (part 15 unlicensed equipment authorizations are permitted if consistent with part 15 rules).

**Judgment:** Compliance, the devices are not include transmitter(s) (or transmitting modes) operating in other licence and licence-exempt services.

## 5 Test Setup Photo

Please refer to the attachment 2405W23590E Test Setup photo.

## 6 E.U.T Photo

Please refer to the attachment 2405W23590EC External photo and 2405W23590EC Internal photo.

**---End of Report---**