

**ELECTROMAGNETIC EMISSIONS COMPLIANCE REPORT  
INTENTIONAL RADIATOR CERTIFICATION TO  
FCC PART 15 SUBPART C REQUIREMENT**

*OF*

**V200 WALKIE TALKIES**

**Model No.: AV-V200, FR-V200, IC-V200, JW-V200, ML-V200, PW-V200,  
SM-V200, ST-V200, SW-V200, SY-V200, TR-V200, VP-V200**

**Trademark: Disney, Barbie, Marvel, Licasfilm Ltd., Spin Master PAW,  
Universal Studios**

**FCC ID: IAJ200N**

**Report No.: ES180319023E**

**Issue Date: March 30, 2017**

*Prepared for*  
**Kiddesigns Inc**  
**1299 Main Street Rahway New Jersey United States**

*Prepared by*  
**EMTEK(SHENZHEN) CO., LTD**

**Bldg 69, Majialong Industry Zone, Nanshan District, Shenzhen,  
Guangdong, China.**

**TEL: 86-755-26954280**

**FAX: 86-755-26954282**

**This report shall not be reproduced, except in full, without the written approval of  
EMTEK(SHENZHEN) CO., LTD.**

**VERIFICATION OF COMPLIANCE**

Applicant:	Kiddesigns Inc 1299 Main Street Rahway New Jersey United States
Manufacturer:	Kiddesigns Inc 1299 Main Street Rahway New Jersey United States
Factory:	Dongguan Willie Plastic & Metal Co., Ltd. No. 23, Dawo Industry One Road, Xiagongtan Industrial Area, Fenggang Town, Dongguan City, Guangdong Province, China
Product Description:	V200 WALKIE TALKIES
Trademark:	Disney, Barbie, Marvel, Hasbro, Licasfilm Ltd., Spin Master PAW, Universal Studios
Model Number:	AV-V200, FR-V200, IC-V200, JW-V200, ML-V200, PW-V200, SM-V200, ST-V200, SW-V200, SY-V200, TR-V200, VP-V200 (Note: The samples are the same except trademark and model number. So FR-V200 was selected for full test.)
FCC ID:	IAJ200N

**We hereby certify that:**

The above equipment was tested by EMTEK(SHENZHEN) CO., LTD. The test data, data evaluation, test procedures, and equipment configurations shown in this report were made in accordance with the procedures given in ANSI C63.10-2013 and the energy emitted by the sample EUT tested as described in this report is in compliance with conducted and radiated emission limits of FCC Rules Part 15.235(2017).

Date of Test : March 19, 2018 to March 29, 2018

Prepared by :   
Yaping Shen/Editor

Reviewer :   
Joe Xia/Supervisor

Approved & Authorized  
Signer :   
Lisa Wang/Manager

### Modified Information

Version	Summary	Revision Date	Report No.
Ver.1.0	Original Report	/	ES180319023E

## Table of Contents

<b>1. GENERAL INFORMATION .....</b>	<b>5</b>
1.1 PRODUCT DESCRIPTION.....	5
<b>2. SYSTEM TEST CONFIGURATION.....</b>	<b>6</b>
2.1 EUT CONFIGURATION .....	6
2.2 EUT EXERCISE .....	6
2.3 TEST PROCEDURE .....	6
2.4 LIMITATION .....	7
2.5 CONFIGURATION OF TESTED SYSTEM.....	8
<b>3. SUMMARY OF TEST RESULTS.....</b>	<b>9</b>
<b>4. DESCRIPTION OF TEST MODES .....</b>	<b>10</b>
<b>5. TEST FACILITY.....</b>	<b>11</b>
<b>6. TEST SYSTEM UNCERTAINTY .....</b>	<b>12</b>
<b>7. CONDUCTED EMISSIONS TEST .....</b>	<b>13</b>
7.1 MEASUREMENT PROCEDURE: .....	13
7.2 TEST SET-UP (BLOCK DIAGRAM OF CONFIGURATION) .....	13
7.3 MEASUREMENT EQUIPMENT USED: .....	13
7.4 MEASUREMENT RESULT: .....	13
7.5 CONDUCTED MEASUREMENT PHOTOS:.....	13
<b>8. RADIATED EMISSION TEST.....</b>	<b>14</b>
8.1 MEASUREMENT PROCEDURE .....	14
8.2 TEST SET-UP (BLOCK DIAGRAM OF CONFIGURATION) .....	14
8.3 MEASUREMENT EQUIPMENT USED: .....	15
8.4 RADIATED EMISSION LIMIT .....	16
8.5 MEASUREMENT RESULTS .....	16
8.6 RADIATED MEASUREMENT PHOTOS:.....	19
<b>9. OCCUPIED BANDWIDTH.....</b>	<b>20</b>
9.1 MEASUREMENT PROCEDURE .....	20
9.2 TEST SET-UP (BLOCK DIAGRAM OF CONFIGURATION) .....	20
9.3 MEASUREMENT EQUIPMENT USED: .....	20
9.4 MEASUREMENT REQUIREMENTS: .....	20
<b>10.ANTENNA APPLICATION .....</b>	<b>22</b>
10.1 ANTENNA REQUIREMENT.....	22
10.2 RESULT .....	22

## 1. GENERAL INFORMATION

### 1.1 Product Description

Characteristics	Description
Product Name	V200 WALKIE TALKIES
Model number	FR-V200
Power Supply	DC 9V Battery
Operating Frequency Range	49.86MHz
Number of Channels	1 channel
Antenna Type	External Antenna
Remark: The EUT continues to transmit while button is being pressed. Modulation by IC, and type is pulse modulation.	

**Note:** for more details, please refer to the User's manual of the EUT.

## 2. System Test Configuration

### 2.1 EUT Configuration

The EUT configuration for testing is installed on RF field strength measurement to meet the Commissions requirement and operating in a manner which intends to maximize its emission characteristics in a continuous normal application.

### 2.2 EUT Exercise

The Transmitter was operated in the normal operating mode. the Tx frequency was fixed which was for the purpose of the measurements.

### 2.3 Test Procedure

#### 2.3.1 Conducted Emissions

The EUT is a placed on as turn table which is 0.8 m above ground plane. According to the requirements in Section 13.1.4.1 of ANSI C63.10-2013. Conducted emissions from the EUT measured in the **frequency range between 0.15 MHz and 30MHz** using **CISPR Quasi-Peak and average detector mode**.

#### 2.3.2 Radiated Emissions

The EUT is a placed on as turn table which is 0.8 m above ground plane. The turn table shall rotate 360 degrees to determine the position of maximum emission level. EUT is set 3m away from the receiving antenna which varied from 1m to 4m to find out the highest emission. And also, each emission was to be maximized by changing the polarization of receiving antenna both horizontal and vertical. In order to find out the max. emission, the relative positions of this hand-held transmitter(EUT) was rotated through three orthogonal axes according to the requirements in Section 13.1.4.1 of ANSI C63.10-2013

## 2.4 Limitation

### (1) Conducted Emission

According to section 15.207(a) Conducted Emission Limits is as following.

Frequency range MHz	Limits dB(uV)	
	Quasi-peak	Average
0.15 to 0.50	66 to 56	56 to 46
0.50 to 5	56	46
5 to 30	60	50

Note

- 1.The lower limit shall apply at the transition frequencies
- 2.The limit decreases linearly with the logarithm of the frequency in the range 0.15 MHz to 0.50 MHz.

### (2) Radiated Emission

- a. The field strength of any emission within this band (section 15.235 frequency between 49.82MHz -49.90MHz) shall not exceed 10000 micro volts/meter at 3 meters. (80dB $\mu$ V at 3m) The emission limit in this paragraph is based on measurement instrumentation employing an average detector. The provisions in section 15.35 for limiting peak emissions apply.
- b. The field strength of any emissions which appear outside of this band shall not exceed the general radiated emission limits in section 15.209(Intentional Radiators general limit).as below.

Frequency (MHz)	Field strength $\mu$ V/m	Distance(m)	Field strength at 3m dB $\mu$ V/m
1.705-30	30	30	69.54
30-88	100	3	40
88-216	150	3	43.5
216-960	200	3	46
Above 960	500	3	54

- Remark
1. Emission level in dBuV/m=20 log (uV/m)
  2. Measurement was performed at an antenna to the closed point of EUT distance of meters.
  3. Only spurious frequency is permitted to locate within the Restricted Bands specified in provision of  $\xi$  15.205
  4. Emission spurious frequency which appearing within the Restricted Bands specified in provision of  $\xi$ 15.205, then the general radiated emission limits in  $\xi$  15.209 apply.

## 2.5 Configuration of Tested System

**Fig. 2-1 Configuration of Tested System**

EUT

Table 2-1 Equipment Used in Tested System

Item	Equipment	Trademark	Model No.	FCC ID	Series No.	Note
1	V200 WALKIE TALKIES	Disney	FR-V200	IAJ200N	N/A	<b><i>EUT</i></b>

**Note:**

- (1) Unless otherwise denoted as EUT in 『Remark』 column , device(s) used in tested system is a support equipment.



### 3. Summary of Test Results

<b>FCC Rules</b>	<b>Description Of Test</b>	<b>Result</b>
§15.207	Conducted Emission	N/A
§15.235	Radiated Emission	Compliant
§15.235	Bandwidth Test	Compliant
§15.203	Antenna Requirement	Compliant

#### 4. Description of test modes

The EUT (V200 WALKIE TALKIES) has been tested under normal operating condition. The EUT stay in continuous transmitting mode. The Frequency 49.860MHz is chosen for testing.

For Radiated: The EUT's antenna was pre-tested under the following modes:

Test Mode	Description
<b>Mode A</b>	<b>X-Y axis</b>
Mode B	Y-Z axis
Mode C	X-Z axis

From the above modes, the worst case was found in Mode A. Therefore only the test data of the mode was recorded in this report.

## 5. Test Facility

### Site Description

EMC Lab : Accredited by CNAS, 2016.10.24  
The certificate is valid until 2022.10.28  
The Laboratory has been assessed and proved to be in compliance with CNAS-CL01:2006 (identical to ISO/IEC 17025:2005)  
The Certificate Registration Number is L2291.

Accredited by TUV Rheinland Shenzhen 2016.5.19  
The Laboratory has been assessed according to the requirements ISO/IEC 17025.

Accredited by FCC, August 03, 2017  
Designation Number: CN1204  
Test Firm Registration Number: 882943

Accredited by Industry Canada, November 24, 2015  
The Certificate Registration Number is 4480A.

Accredited by A2LA, July 31, 2017  
The Certificate Number is 4321.01.

Name of Firm : EMTEK(SHENZHEN) CO., LTD.  
Bldg 69, Majialong Industry Zone, Nanshan District, Shenzhen, Guangdong, China.

## 6. TEST SYSTEM UNCERTAINTY

The following measurement uncertainty levels have been estimated for tests performed on the apparatus:

Parameter	Uncertainty
Radio Frequency	$\pm 1 \times 10^{-5}$
Maximum Peak Output Power Test	$\pm 1.0\text{dB}$
Conducted Emissions Test	$\pm 2.0\text{dB}$
Radiated Emission Test	$\pm 2.0\text{dB}$
Power Density	$\pm 2.0\text{dB}$
Occupied Bandwidth Test	$\pm 1.0\text{dB}$
Band Edge Test	$\pm 3\text{dB}$
All emission, radiated	$\pm 3\text{dB}$
Antenna Port Emission	$\pm 3\text{dB}$
Temperature	$\pm 0.5^\circ\text{C}$
Humidity	$\pm 3\%$

Measurement Uncertainty for a level of Confidence of 95%

## 7. Conducted Emissions Test

### 7.1 Measurement Procedure:

1. The EUT was placed on a table which is 0.8m above ground plane.
2. Maximum procedure was performed on the six highest emissions to ensure EUT compliance.
3. Repeat above procedures until all frequency measured were complete.

### 7.2 Test SET-UP (Block Diagram of Configuration)

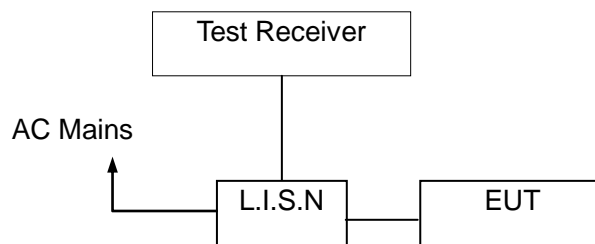

### 7.3 Measurement Equipment Used:

Item	Equipment	Manufacturer	Model No.	Serial No.	Last Cal.	Cal. Interval
1.	Test Receiver	Rohde&Schwarz	ESCS30	100018	May 16, 2017	1 Year
2.	L.I.S.N.	Rohde&Schwarz	ENV216	100017	May 16, 2017	1Year
3.	RF Switching Unit	CDS	RSU-M2	38401	May 16, 2017	1Year

### 7.4 Measurement Result:

N/A.

### 7.5 Conducted Measurement Photos:

N/A

## 8. Radiated Emission Test

### 8.1 Measurement Procedure

1. The EUT was placed on a turn table which is 0.8m above ground plane.
2. Maximum procedure was performed on the six highest emissions to ensure EUT compliance.
3. And also, each emission was to be maximized by changing the polarization of receiving antenna both horizontal and vertical.
4. Repeat above procedures until all frequency measured were complete.

### 8.2 Test SET-UP (Block Diagram of Configuration)

(A) Radiated Emission Test Set-Up, Frequency Below 30MHz

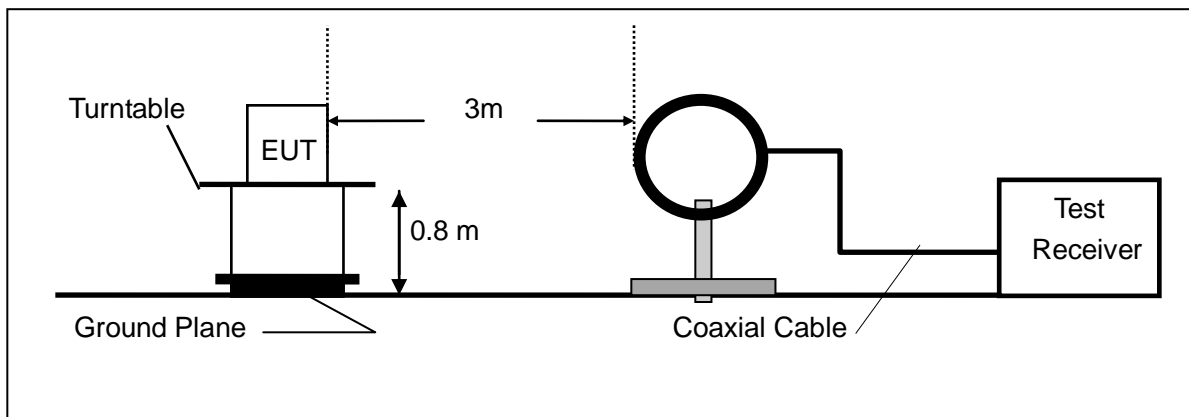

(B) Radiated Emission Test Set-Up, Frequency Above 30MHz

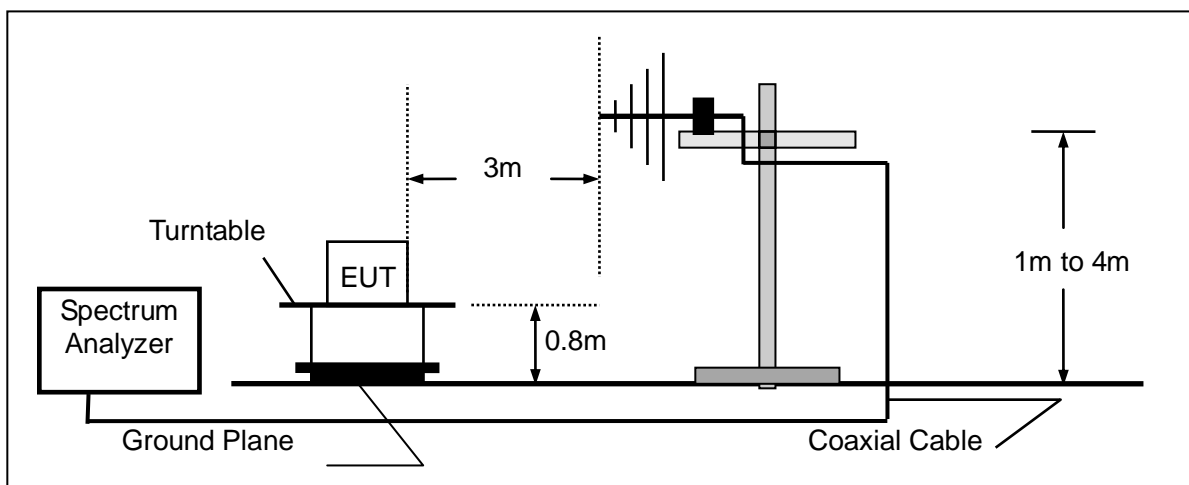

### 8.3 Measurement Equipment Used:

Item	Equipment	Manufacturer	Model No.	Serial No.	Last Cal.	Cal. Interval
1.	Test Receiver	Rohde & Schwarz	ESCI	1166.5950.03	May 16, 2017	1 Year
2.	Bilog Antenna	Schwarzbeck	VULB9163	000141	May 16, 2017	1 Year
3.	Power Amplifier	CDS	RSU-M352	818	May 16, 2017	1 Year
4.	Power Amplifier	HP	8447F	OPT H64	May 16, 2017	1 Year
5.	Color Monitor	SUNSPO	SP-140A	N/A	May 16, 2017	1 Year
6.	Single Line Filter	JIANLI	XL-3	N/A	May 16, 2017	1 Year
7.	Single Phase Power Line Filter	JIANLI	DL-2X100B	N/A	May 16, 2017	1 Year
8.	3 Phase Power Line Filter	JIANLI	DL-4X100B	N/A	May 16, 2017	1 Year
9.	DC Power Filter	JIANLI	DL-2X50B	N/A	May 16, 2017	1 Year
10.	Cable	Schwarzbeck	PLF-100	549489	May 16, 2017	1 Year
11.	Cable	Rosenberger	CIL02	A0783566	May 16, 2017	1 Year
12.	Cable	Rosenberger	RG 233/U	525178	May 16, 2017	1 Year
13.	Signal Analyzer	Rohde & Schwarz	FSV30	103040	May 16, 2017	1 Year
14.	Horn Antenna	Schwarzbeck	BBHA9120D	9120D-1272	May 16, 2017	1 Year
15.	Power Amplifier	LUNAR EM	LNA1G18-40	J10100000081	May 16, 2017	1 Year
16.	Cable	H+S	CBL-26	N/A	May 16, 2017	1 Year
17.	Cable	H+S	CBL-26	N/A	May 16, 2017	1 Year
18.	Cable	H+S	CBL-26	N/A	May 16, 2017	1 Year

### 8.4 Radiated Emission Limit

The emissions from an intentional radiator shall not exceed the field strength levels specified in the following table 15.209(a):

Frequencies (MHz)	Field Strength (microrvolts/meter)	Measurement Distance (meters)
0.009~0.490	2400/F(KHz)	300
0.490~1.705	24000/F(KHz)	30
1.705~30.0	30	30
30~88	100	3
88~216	150	3
216~960	200	3
Above 960	500	3

Restricted bands of operation

MHz	MHz	MHz	GHz
0.090 - 0.110	16.42 - 16.423	399.9 - 410	4.5 - 5.15
<sup>1</sup> 0.495 - 0.505	16.69475 - 16.69525	608 - 614	5.35 - 5.46
2.1735 - 2.1905	16.80425 - 16.80475	960 - 1240	7.25 - 7.75
4.125 - 4.128	25.5 - 25.67	1300 - 1427	8.025 - 8.5
4.17725 - 4.17775	37.5 - 38.25	1435 - 1626.5	9.0 - 9.2
4.20725 - 4.20775	73 - 74.6	1645.5 - 1646.5	9.3 - 9.5
6.215 - 6.218	74.8 - 75.2	1660 - 1710	10.6 - 12.7
6.26775 - 6.26825	108 - 121.94	1718.8 - 1722.2	13.25 - 13.4
6.31175 - 6.31225	123 - 138	2200 - 2300	14.47 - 14.5
8.291 - 8.294	149.9 - 150.05	2310 - 2390	15.35 - 16.2
8.362 - 8.366	156.52475 - 156.52525	2483.5 - 2500	17.7 - 21.4
8.37625 - 8.38675	156.7 - 156.9	2690 - 2900	22.01 - 23.12
8.41425 - 8.41475	162.0125 - 167.17	3260 - 3267	23.6 - 24.0
12.29 - 12.293	167.72 - 173.2	3332 - 3339	31.2 - 31.8
12.51975 - 12.52025	240 - 285	3345.8 - 3358	36.43 - 36.5
12.57675 - 12.57725	322 - 335.4	3600 - 4400	( <sup>2</sup> )

- Remark 1. Emission level in dBuV/m=20 log (uV/m)  
 : 2. Measurement was performed at an antenna to the closed point of EUT distance of meters.  
 3. Only spurious frequency is permitted to locate within the Restricted Bands specified in provision of § 15.205, and the emissions located in restricted bands also comply with 15.209 limit.

### 8.5 Measurement Results

Test Result: PASS      Test By: Andy  
 Frequency Range: 30M-1GHz      Fundamental Frequency: 49.860 MHz



Horizontal:

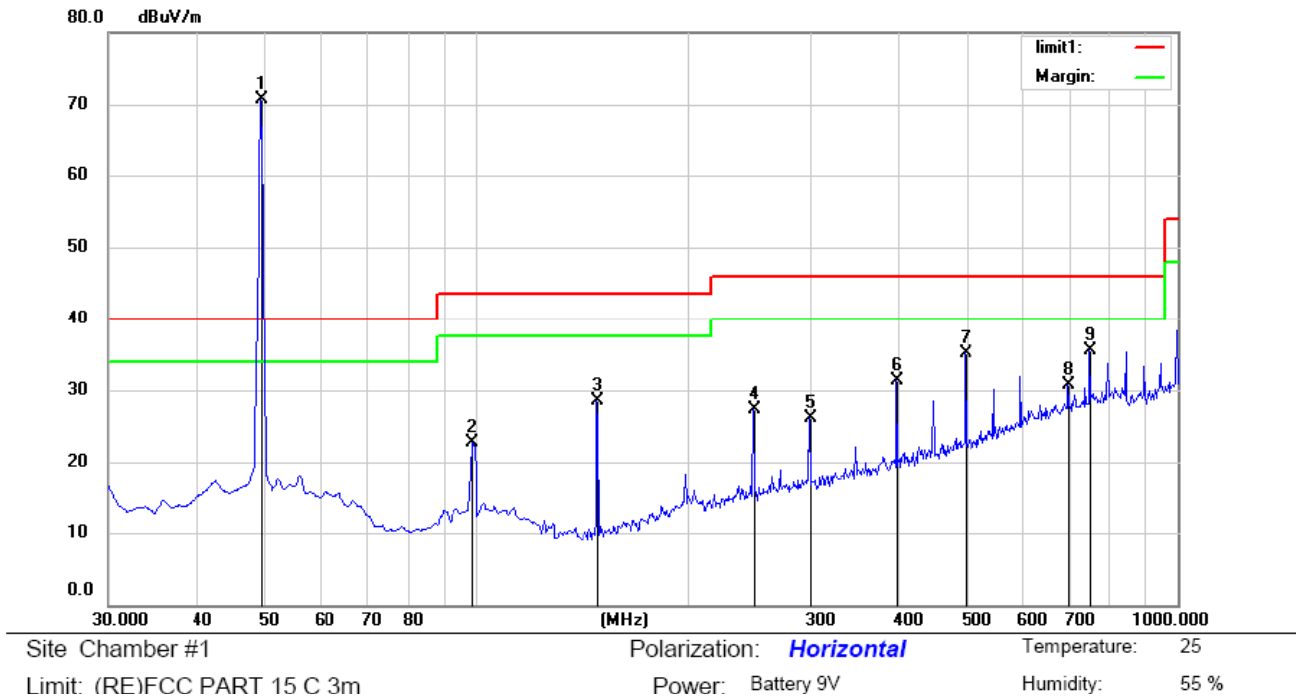

Vertical:

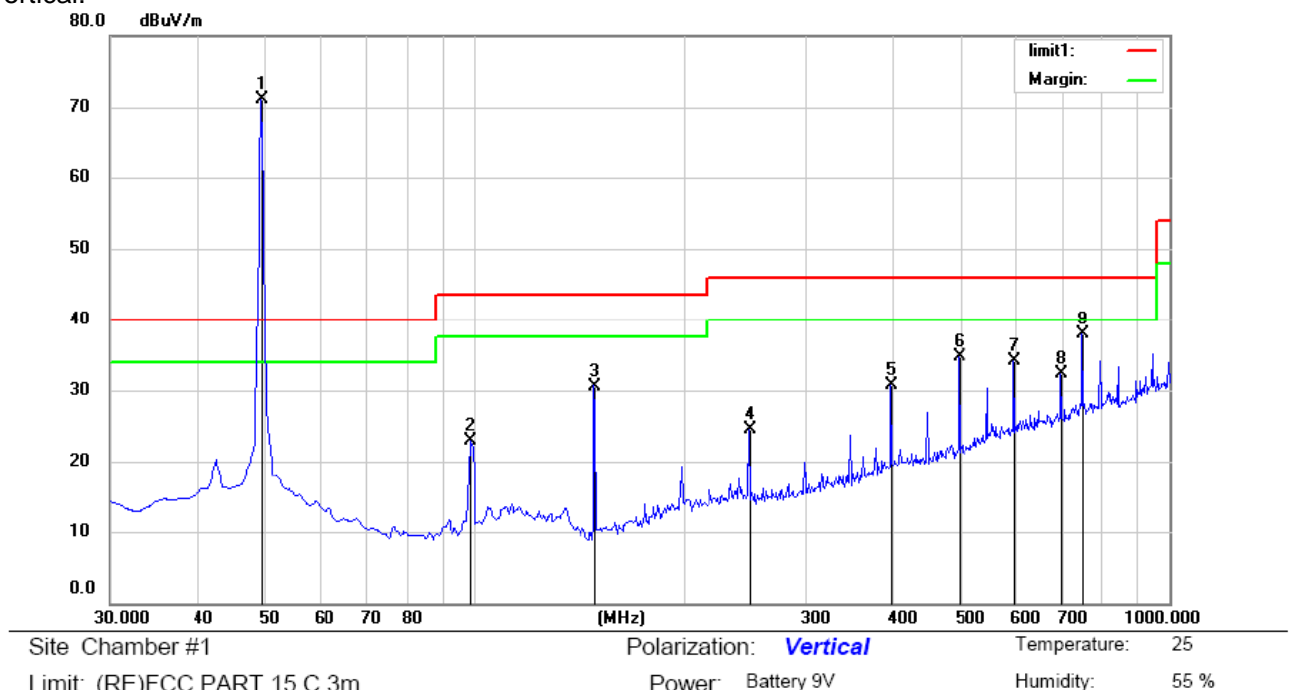

Frequency (MHz)	Ant.Pol. (V/H)	Emission Level (dBuV/m)	Limit 3m (dBuV/m)	Margin (dB)	Note
49.86	H	70.76	100.00	-29.24	Peak
49.86	H	70.62	80.00	-9.38	AV
98.87	H	28.47	43.50	-15.03	QP
149.31	H	27.39	43.50	-16.11	QP
249.22	H	26.10	43.50	-17.40	QP
298.69	H	31.27	46.00	-14.73	QP
398.60	H	35.06	46.00	-10.94	QP
498.51	H	30.74	46.00	-15.26	QP
698.33	H	35.46	46.00	-10.54	QP
747.80	H	26.16	46.00	-19.84	QP
49.86	V	71.12	100.00	-28.88	Peak
49.86	V	70.14	80.00	-9.86	AV
98.87	V	22.91	43.50	-20.59	QP
149.31	V	30.60	43.50	-12.90	QP
249.22	V	24.47	43.50	-19.03	QP
398.60	V	30.71	46.00	-15.29	QP
498.51	V	34.72	46.00	-11.28	QP
598.42	V	34.10	46.00	-11.90	QP
698.33	V	32.38	46.00	-13.62	QP
747.80	V	37.94	46.00	-8.06	QP

**No others harmonics emissions are higher than 20dB below the limits of 47 CFR Part 15.209.**

**8.6 Radiated Measurement Photos:**



## 9. Occupied Bandwidth

### 9.1 Measurement Procedure

1. Set EUT as normal operation
2. Set SPA Center Frequency = fundamental frequency, RBW=300Hz,VBW= 1KHz
3. Set SPA Max hold. Mark peak.

### 9.2 Test SET-UP (Block Diagram of Configuration)

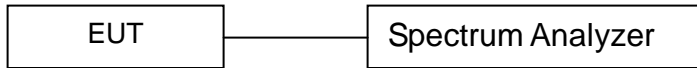

### 9.3 Measurement Equipment Used:

EQUIPMENT TYPE	MFR	MODEL NUMBER	SERIAL NUMBER	LAST CAL.	CAL DUE.
Spectrum Analyzer	Rohde & Schwarz	FSV30	1321.3008K	05/16/2017	05/15/2018
Coaxial Cable	CDS	79254	46107086	05/16/2017	05/15/2018

### 9.4 Measurement Requirements:

Pass.

Limits for 26dB Bandwidth of Fundamental Emission:

Frequency (MHz)	26dB Bandwidth (KHz)	Limits (MHz)
49.86	1.73	Within 49.82-49.90

Refer to attached data chart.

## Band Width Test Data

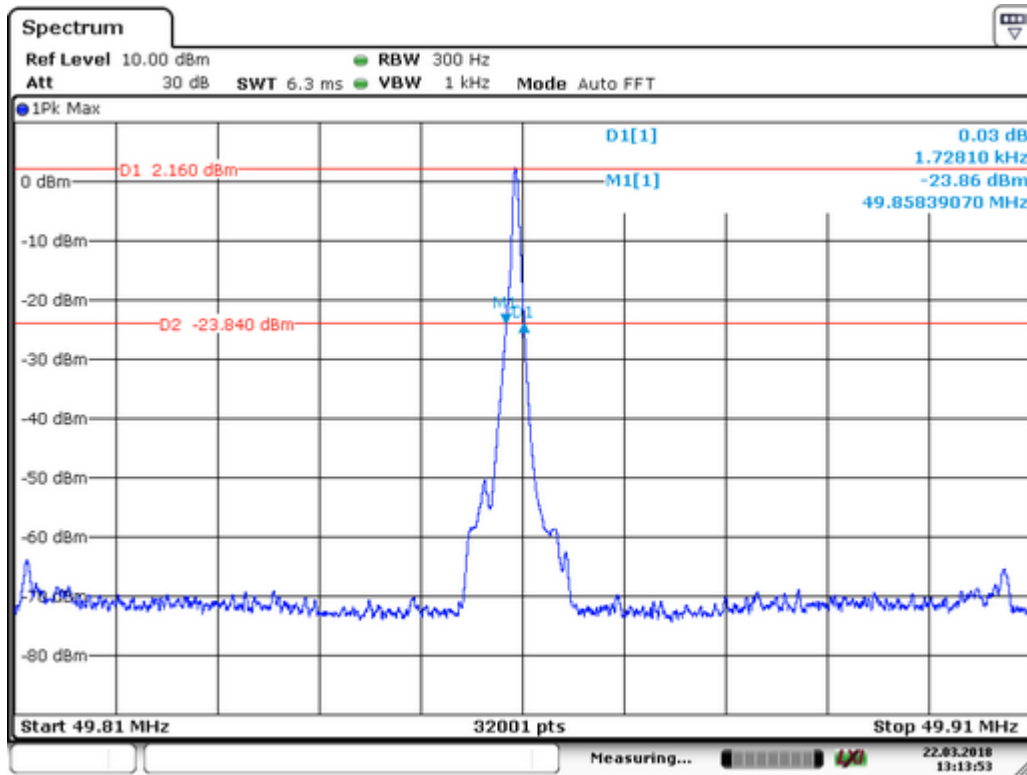

## **10. Antenna Application**

### **10.1 Antenna requirement**

The EUT'S antenna is met the requirement of FCC part 15C section 15.203.

Systems operating in the 49.86MHz that are used exclusively for fixed, point-to-point operations may employ transmitting antennas with directional gain greater than 6dBi provided the maximum peak output power of the intentional radiator is reduced by 1dB for every 3dB that the directional gain of the antenna exceeds 6dBi.

### **10.2 Result**

The EUT's antenna is permanent attached antenna, external antenna. The antenna is not replaceable or user serviceable. The requirement of FCC part 15C section 15.203 is met.

# APPENDIX I (PHOTOS OF EUT)









