



LPT-900

900 MHz Spread Spectrum Data Transmitter

Michelle Zuliani

This document, submitted in confidence, contains proprietary information which shall not be reproduced or transferred to other documents, disclosed to others, used for manufacturing or any other purpose without the prior written permission of OMNEX Control Systems ULC.

© Copyright 2009 OMNEX Control Systems ULC.

All rights reserved.

Company Confidential: OMNEX Control Systems ULC.

CONTENTS

1	Introduction	4
2	Specifications	4
3	Technical Description.....	4
3.1	Block Diagram	4
3.2	Theory of Operation	6
3.3	General Description of LPT-900 Transmitter	6
3.4	Power Supply	6
3.5	Transmitter	6
3.6	Synthesizers and Digital Clocks generation	6
3.7	Microcontroller	7
3.8	Communication Interfaces	7
3.9	Emission Types	7
3.10	Antenna	7
4	Spread Spectrum Operation	7
4.1	Channel Plan	8
4.2	Per Hop Activities	8
5	FCC/IC Identification Labelling	8
5.1	FCC and IC Identification Label Placement	8
6	LPT-900 Transmitter Module Photographs	8

1 Introduction

The LPT-900 is a frequency hopped spread spectrum transmitter module designed to be compatible with US (FCC Part 15.247) and Canadian (RSS-210) regulations for license free use in the 900 MHz ISM band.

The transmitter is integrated into the T110, T150 or T300 remote control products.

2 Specifications

The module's specifications are outlined in Table 1.

Parameter	Min	Typ	Max	Units
Frequency Range	902.2		927.7	MHz
DC Supply Voltage	4.0	6	18	VDC
Frequency Stability (synthesized with VCTCXO reference)		+/- 2.5		PPM
Operating Temperature	-30		+70	°C
Transmitter R.F. Power Output		+10		dBm

Table 1 – Module Specifications

Type of Emission: Frequency Hopping Spread Spectrum

Number of Radio Channels: 256

Modulation: FSK

Data Rates: 4.8 kbps

3 Technical Description

3.1 Block Diagram

A block diagram is shown in Figure 1.

Title
Subject

- 5 -

Revision 0.1

LPT900 Rev 9 Block Diagram

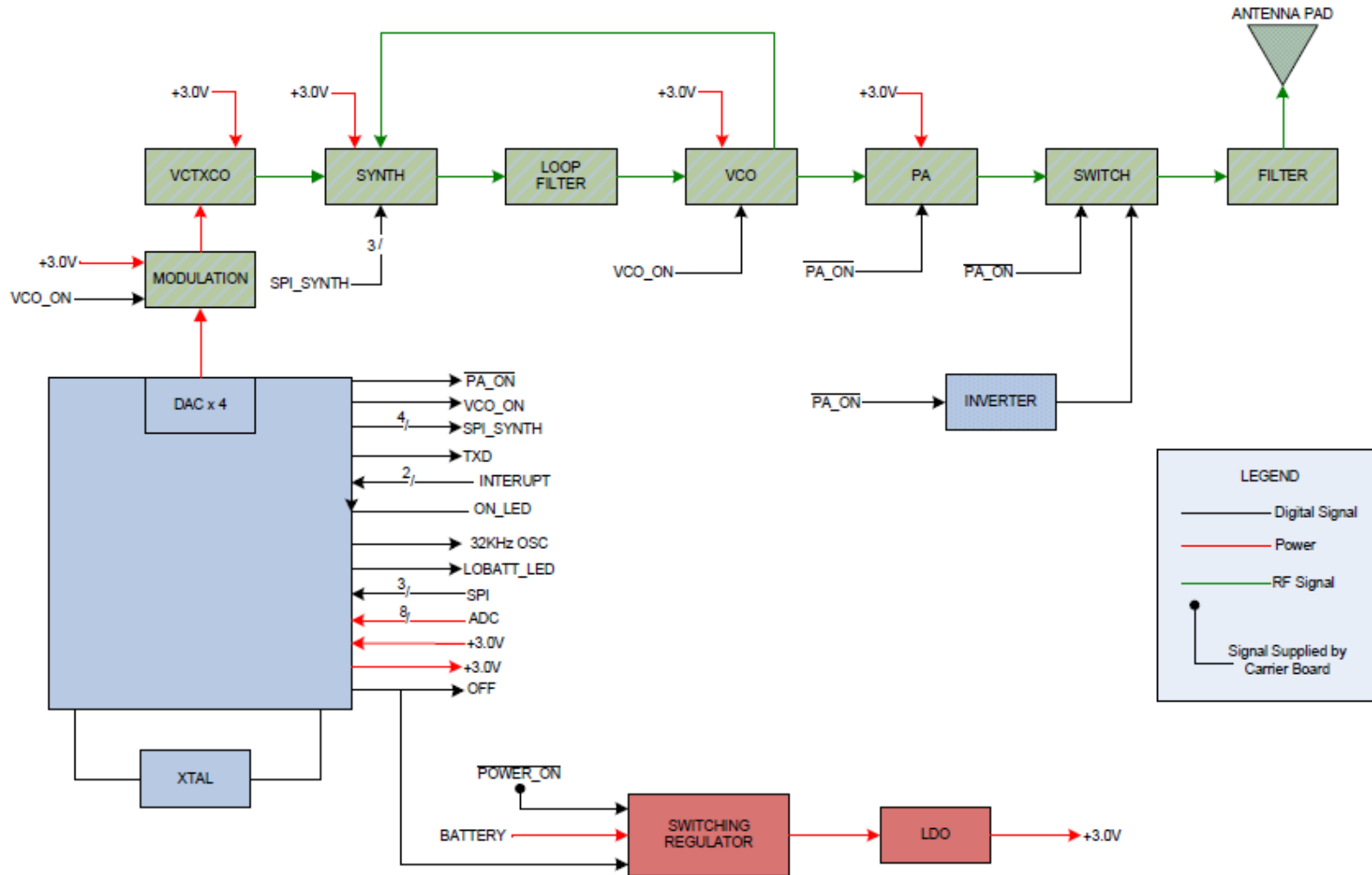

3.2 Theory of Operation

The operation is described based on the block diagram shown in Figure1.

The transmitter receives the data from a serial interface and then transfers it to the CPU. The digital data is converted to an analogue signal whose reference level and amplitude modulate a 13 MHz VCTCXO. The modulated output of the VCTCXO is fed to a synthesizer (SYNTH). The synthesizer generates a current which is sent to the input of the LOOP FILTER. The voltage generated at the output of the loop filter is fed to the input of the voltage controlled oscillator (VCO). The VCO generates an RF frequency which is proportional to the input voltage level. The resulting RF signal energy is sent to a power amplifier (PA) which boosts the signal level. The signal is then passed through a SWITCH, filtered (FILTER) and sent to the antenna. The SWITCH is only turned 'on' when data is available for transmission. The switch is turned 'off' to reduce conducted emissions when there is no data to transmit.

The transmitter contains a step-down switcher (SWITCHING REGULATOR) which generates a constant 3.3 V. The output of the switcher is sent to an LDO which generates 3.0V. The main time reference for the CPU is a 3.6864 MHz TXCO (X-TAL).

Figure 1 shows all the possible sources of conducted or radiated emissions.

3.3 General Description of LPT-900 Transmitter

The LPT-900 is a frequency hopping spread spectrum (FHSS) transmitter designed to be compatible with FCC Part 15.247 (US) and RSS-210 (Canada) regulations for license free operation in the 900MHz frequency band. The major elements include a frequency agile RF transmitter, a microcontroller that provides control and a power supply.

At each frequency hop one packet is sent by the transmitter which is received by a separate receiver unit. The transmitter generates the baseband waveforms. The microcontroller generates a pseudo random frequency hop sequence of length 256 based on a memorized table. The band is utilized in equally spaced 100 KHz channels.

3.4 Power Supply

Refer schematic diagram DSCH-2238R09 sheet 2.

There is a single step-down switcher (U8) and linear regulator (U7) on the board. The switcher converts the variable DC input voltage to 3.3V and the linear regulator which supplies all the circuitry is fed from this rail.

3.5 Transmitter

Refer to schematic diagram DSCH-2238R09 sheets 2 and 3.

U11 is the microcontroller which sends digital data to a series of OP-amps (U6) which converts the data to analogue format. The analogue signal is used to modulate the voltage control pin of the VCTCXO (X2). (U5) is the synthesizer which with a loop filter produces a voltage input. U1 is the VCO which produces an RF frequency proportional to the input voltage produced by the synthesizer and loop filter. U2 is the power amplifier which boosts the RF power. U4 is a switch which connects the output of the PA to the antenna while in transmit mode. X1 is a filter which is used to suppress spurious.

3.6 Synthesizers and Digital Clocks generation

Refer to schematic diagram DSCH-2238R09 sheets 2 and 3.

The LOs and the timing signals generated inside LPT-900 are derived from a 13 MHz VCTCXO (X2) and a 3.6864 MHz crystal (X3).

The VCTCXO is modulated and is used as the reference frequency for the synthesizer. The RF frequency is created by the synthesizer (U5) and VCO (U1) and is controlled by the processor (U11).

The 3.6864 MHz crystal (X3) generates the reference frequency for the processor (U11).

3.7 Microcontroller

See schematic diagram DSCH-2238R09 sheet 2.

The microcontroller U11 is responsible for control of the entire board. The microcontroller programs the frequency synthesizers (U5), turns on the PA (U2) and controls the switch (U4).

3.8 Communication Interfaces

See schematic diagram DSCH-2238R09 sheet 2.

The LPT-900 supports a serial interface and can send and receive a series of analogue and digital signal which are routed to the external world through test points (CN3 though CN26) .

The transmitter over the air data rate is 4.8 kbps. .

3.9 Emission Types

In the list below the first name is the block name from the block diagram and the second name is the reference name in the schematic. The LPT-900 transmitter contains the following fixed frequency sources:

VCTCXO (X2) – 13 MHz TCXO

XTAL (X3) – 3.6864 MHz crystal

CPU (U11) –134 KHz SPI clock for the synthesizer

CPU (U11) – 3.6864 MHz clock for the microcontroller

The transmitter contains the following variable frequency source:

SYNT – U5 - 902.2 – 927.7 MHz in 100 KHz steps

3.10 Antenna

The antenna consists of an internal sleeved dipole. The gain of the dipole is 1.76 dBi.

4 Spread Spectrum Operation

The LPT-900 is a frequency hopping spread spectrum 902.2-927.2 MHz transmitter platform specifically designed for industrial remote control applications. The transmitter is capable of accepting a wide range of input voltages and is able to operate across a broad temperature range. This has been designed to withstand ISM band interference while ensuring the integrity of each data packet. This is accomplished via the OMNEX OmUD data protocol.

Frequency hopping spread spectrum technology was originally developed by the U.S. military to prevent interference or interception of radio transmissions on the battlefield. Frequency hopping devices concentrate their full power into a very narrow signal and randomly hop from one frequency to another within a designated frequency band. If they encounter interference on a particular frequency, the devices error checks the affected data, hops to another point on the spectrum, and resumes communications on subsequent hops.

4.1 Channel Plan

The LPT-900 transmitter module operates on 256 channels with central frequencies between 902.2 and 927.7 MHz. These 256 channels are divided into 4 groups consisting of 64 frequencies. Each radio is configured to hop in one of these 4 groups. In order to link, radios must be configured to operate in the same group. The 64 frequencies are used to generate a pseudo random sequence of 63 frequencies which are equally used. The channels are spaced 100 KHz apart. The channel bandwidth is 37 KHz.

The hop sequence is a sequence of 63 numbers randomly generated with a proprietary algorithm. The unique serial number of the transmitter is used as a seed to the random number generator. The random number generator creates a list of 26 channels from the 27 available channels. This list of 63 channels is used to lookup in the frequency table to determine the next frequency.

4.2 Per Hop Activities

The dwell time (the amount of time the transmitter is on one single channel) is 19.64 ms. A full hop cycle takes 1.575 s.

5 FCC/IC Identification Labelling

5.1 FCC and IC Identification Label Placement

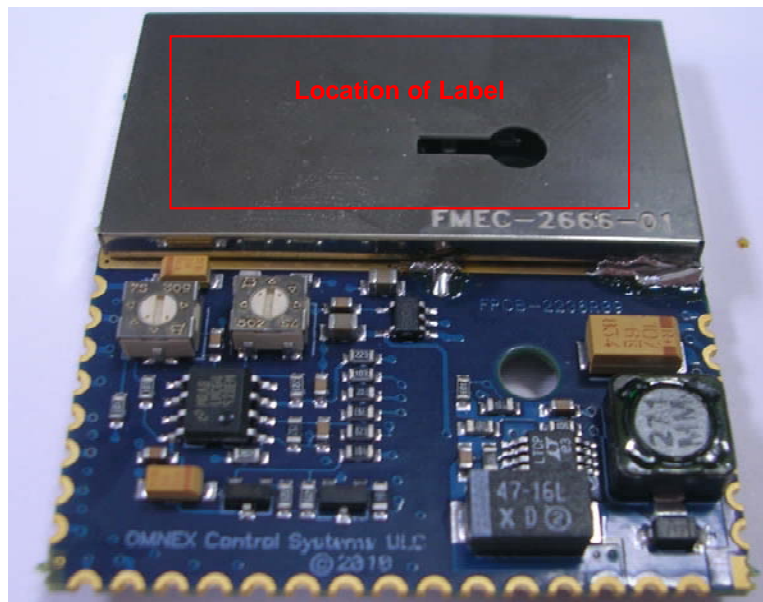

6 LPT-900 Transmitter Module Photographs

Photographs of the transmitter are show below in Figures 2 and 3.



Figure 2 – Shield Side of Transmitter



Figure 3 – Bottom Side of Transmitter