



**TIME/Versalift  
Digger Derrick  
Control System**

**Installation and Operations Manual**

Issue 10  
March 21, 2000

© 2000 OMNEX Control Systems Inc.  
All rights reserved.

# Contents

1.	Introduction.....	1
1.1.	Part Numbers .....	1
2.	Physical Mounting.....	4
3.	Considerations for Electrowelding.....	5
4.	Electrical Connections .....	6
5.	Fuses, Configuration Jumpers .....	11
5.1.	R1300 Board .....	11
5.2.	S20 Board.....	11
6.	Setting Up the Radio Receiver .....	12
6.1.	Unique Identifier (Radio ID).....	12
6.2.	No-Link Data Mode.....	13
6.3.	Changing Switch Settings .....	13
7.	Operations .....	14
7.1.	Receiver/Controller.....	14
7.1.1.	Error Codes .....	14
7.2.	T45 Radio Transmitter .....	14
7.2.1.	Switching The Transmitter ON and OFF.....	14
7.2.2.	Operator Controls:.....	15
7.2.3.	Tilt Failsafe.....	15
7.2.4.	Low Battery Indicator.....	16
7.2.5.	Battery Charging and Replacement .....	16
7.2.6.	Transmitter Light Summary .....	16
7.2.7.	Numeric Display.....	17
7.3.	T47 Cable Remote .....	18
7.4.	Emergency Override Panel .....	18
8.	Proportional Drive Adjustments.....	19
9.	Factory Parameters .....	24
9.1.	Types of Factory Parameters .....	24
9.2.	Changing the Factory Parameters .....	24
9.3.	List of Factory Parameters.....	25
	PWM Drive Frequency Parameters.....	28
	Boom Load Moment Limit .....	28
	Boom Derating Factors .....	28
	Emergency Override Panel Function Speed .....	28
	Auger Shake Speed .....	28
	Digger Transmission Type.....	28
10.	Warranty .....	29

# 1. Introduction

The TIME/Versalift Digger Derrick Control System consists of a custom Controller/Receiver (grey box), an optional T45 Radio Transmitter and/or an optional T47 Cable Remote. An interface is also provided for an optional user-supplied Emergency Override Panel. The main components of the Controller/Receiver are an R1300+ (APCB-1225-10) circuit board, a PWM/V Converter Board, an S20 (APCB-1458-xx) board, and a REX-900 radio receiver.

The Controller/Receiver's software is custom-designed for the Digger Derrick application. Various sensors mounted on the machine chassis send feedback information to the Controller/Receiver. This feedback information together with the operator commands determine the drive outputs to the Apitech™ electric-over-hydraulic valves. A sophisticated computer program, permanently encoded into the firmware chips of the Controller/Receiver, governs the mapping of inputs to outputs.

Features of the computer program include safety interlocks to prevent injury to personnel as well as damage to the machine. The program incorporates a “restart” check which ensures that functions do not actuate unexpectedly due to operator panel switches being left “on” by accident.

All wiring to the Controller/Receiver is through waterproof circular M.S. connectors on the outside of the fibreglass enclosure, to ensure that the NEMA 4X rating of the enclosure is preserved. This manual describes considerations which should be taken during installation and operation, and gives procedures for “tuning” the system to match the exact characteristics of your hydraulic valves.

## 1.1. Part Numbers

The list below gives the part numbers of the major components of the Digger Derrick Control System. You will need these numbers when ordering spare parts.

Component	OMNEX Part Number	Versalift Part Number
<b>R1302 Controller (works with T47 and T247 only)</b>	<b>ASSY-1732-01</b>	<b>19423-1</b>
R1300+ Board, 12V (main board)	TPCB-1225-10	—
Firmware (EPROM chip) for R1300+ board	AFRM-1438-30	—
PWM/V Converter Board	TPCB-1496-05	—
S20 Board	TPCB-1458-03	—
<b>R1305 Receiver (supports T45, T47 and T247)</b>	<b>ASSY-1732-02</b>	<b>19290-1</b>
R1300+ Board, 12V (main board)	TPCB-1225-10	—
Firmware (EPROM chip) for R1300+	AFRM-1438-30	—

board		
S20 Board	TPCB-1458-03	—
PWM/V Converter Board	TPCB-1496-05	—
Radio Transmitter Board	TPCB-1756-01	—
REX-900 Radio Receiver	ASSY-1190-01	—
<b>R2305 Receiver (supports T245, T47 and T247)</b>	<b>ASSY-1732-02</b>	<b>19425-1</b>
R1300+ Board, 12V (main board)	TPCB-1225-10	—
Firmware (EPROM chip) for R1300+ board	AFRM-1438-??	—
S20 Board	TPCB-1458-03	—
DEX-900 Radio Receiver		—
<b>Factory Key for Controller/Receiver</b>	<b>ACAB-1355-02</b>	
<b>User Key for Controller/Receiver</b>	<b>ACAB-1355-01</b>	
<b>Shock Mount Kit for Controller/Receiver</b>	<b>AKIT-1498-01</b>	
<b>Output Cable with 54-pin Connector, 6 feet</b>	<b>ACAB-1733-01</b>	—
<b>Emergency Override Panel Interface Cable with 16-pin Connector, 6 feet</b>	<b>ACAB-1734-01</b>	—
<b>Custom Output Harness</b>	<b>ACAB-1974-01</b>	<b>19293-1</b>
<b>Custom Emergency Override Panel Harness</b>	<b>ACAB-1975-01</b>	<b>19388-1</b>
<b>Engine Interface Module, Navistar®</b>		
<b>T45 Radio Transmitter</b>	<b>ASSY-1326-25</b>	<b>19291-1</b>
TX50 Board (long board)	TPCB-1185-01	—
Interface Board (small board)	TPCB-1302-01	—
Display Board	TPCB-1736-01	—
<b>T245 Radio Transmitter</b>	<b>ASSY-1993-01</b>	<b>19291-1</b>
TX50 Board (long board)	TPCB-1847-01	—
Interface Board (small board)	TPCB-1302-01	—
Display Board	TPCB-1966-02	—
<b>Platform Magnet for T45/T245</b>		
<b>T47 Cable Remote (no display)</b>	<b>ASSY-1312-15</b>	—
UMB Board (long board)	TPCB-1235-01	—
Interface Board (small board)	TPCB-1302-01	—

<b>T247 Cable Remote</b>		<b>19424-1</b>
UMB Board (long board)	TPCB-1235-01	—
Interface Board (small board)	TPCB-1302-01	—
Display Board	TPCB-1736-02	—
<b>Umbilical Cable for T47 or T247, 20 feet</b>		
<b>Dual-Axis Joystick with Trigger-Style Deadman Button for <i>RIGHT</i> joystick</b>	<b>AKIT-9048-01</b>	
<b>Dual-Axis Joystick with Trigger-Style Deadman Button for <i>LEFT</i> joystick</b>	<b>AKIT-9048-02</b>	
<b>Boot Kit for Dual-Axis Joystick</b>	<b>AKIT-9033-02</b>	
<b>Paddle-Style Joystick</b>	<b>AKIT-1610-01</b>	
<b>T45/T245 Battery</b>	<b>B0001</b>	—
<b>Battery Charger, 120VAC</b>	<b>B0008</b>	—
<b>Battery Charger, 12V with Cigar Lighter Plug</b>	<b>B0007</b>	—
<b>Installation and Operations Manual</b>	<b>DMAN-1976-01</b>	

## 2. Physical Mounting

The Controller/Receiver should be mounted with the connectors down, and in a location so that the enclosure door may be opened conveniently for access to the inside.

**Shock mounts must be used to mount the enclosure!** Under no circumstances should the enclosure be directly bolted to the machine. Figure 1 below illustrates how the shock mounts should be installed:

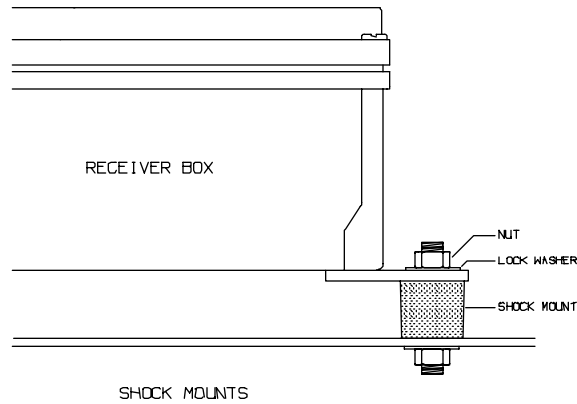
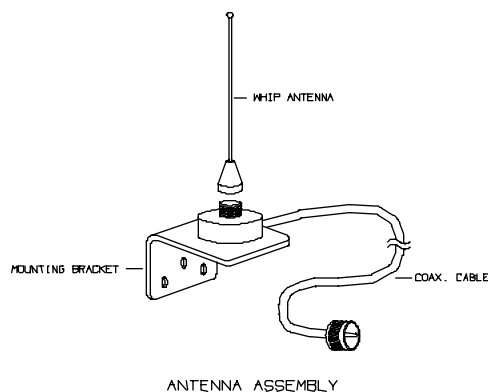

**Figure 1** Enclosure Mounting

The Controller/Receiver enclosure is sealed and has a NEMA-4 rating. When installing, ensure that nothing is done to compromise the watertightness of the enclosure. When performing maintenance it may be necessary to gain access to the inside of the enclosure; take care to re-close the door securely when you are done.

The receiver antenna should be mounted pointing up and as high as possible, preferably with a large metal surface below it but no metal above or to the side. The antenna must be mounted on the *outside* of the machine; do not mount it inside an operator's cab or in a toolbox. Assemble the antenna as shown in Figure 2 below, and thread (finger-tight only) the connector onto the matching receptacle on the Controller/Receiver.

**Figure 2** Antenna Assembly



### **3. Considerations for Electrowelding**

The electronics in the Digger Derrick Control System can be damaged by the high currents and voltages employed in electrowelding. If electrowelding must be performed after the Control System has been installed, observe the following precautions to reduce the risk of damage:

- Do not connect the ground clip to a point on the chassis close to the enclosures.
- Disconnect the harnesses to the enclosures and sensors at the M.S. connectors. Also disconnect the battery (PTO switch) and ground connections going into the enclosures.
- Do not strike an arc close to the enclosures and sensors, or wiring leading into the enclosures and sensors.
- Do not weld to the sensors.

## 4. Electrical Connections

The Receiver/Controller has two circular M.S. connectors for connection to your chassis wiring. A 54-pin M.S. connector is used for power and function outputs. A 16-pin M.S. connector is provided for connection to the T47 Cable Remote or Emergency Override Panel. The following tables specify the assignment of each pin, with corresponding markings on the circuit boards for reference. The wire numbers refer to the old-style Output Cable and not the new Custom Output Harness.

### Main Connector (Power and Functions):

Function	Wire #	54-pin (32A10P) M.S. Pin	Board References
Ground	48,38	A, AF	J15 (R1300), J3 (S20)
Power for Electronics (Battery Positive)	39	AG	J12 (R1300), J1 (S20)
Power for Function Outputs (Batt. +)	yellow +green	B	J14 (R1300)
Dump Valve Output (drives power out when radio signal is being received from transmitter)	49	C	J13 (R1300), J2 (S20)
Engine START	24	D	D2 (R1300)
Engine STOP	47	E	D1 (R1300)
Winch DOWN	29	F	1+ (R1300)
Winch UP	25	G	1- (R1300)
Digger DIG	46	H	2+ (R1300)
Digger CLEAN	45	J	2- (R1300)
Lower Boom LOWER	5	K	3+ (R1300)
Lower Boom RAISE	14	L	3- (R1300)
Intermediate Boom EXTEND	23	M	4+ (R1300)
Intermediate Boom RETRACT	26	N	4- (R1300)
Upper Boom EXTEND	3	O	5+ (R1300)
Upper Boom RETRACT	22	P	5- (R1300)
Pole Guide/Platform LOWER	44	R	6+ (R1300)
Pole Guide/Platform RAISE	30	S	6- (R1300)
Boom Rotate CCW	6	T	O1 (S20)



Boom Rotate CW	13	U	O2 (S20)
Pole Guide/Platform OPEN	12	V	O3 (S20)
Pole Guide/Platform CLOSE	21	W	O4 (S20)
Digger Shift HIGH	27	X	O5 (S20)
Digger Shift LOW	4	Y	O6 (S20)
Auger LATCH	2	Z	D4 (R1300)
Auger UNLATCH	20	a	D5 (R1300)
Throttle UP	31	b	D6 (R1300)
Throttle DOWN	7	c	D7 (R1300)
Emergency Power	9	d	D3 (R1300)
Electronic Throttle Output (0 to 5V)	1	e	O9 (S20) via PWM/V Converter Board
Hydraulic Tool Valve	43	f	D8 (R1300)
Upper Boom Extended Switch (N.O. contact)	32	g	J2 pin 6 (R1300)
Intermediate Boom Retracted Switch (N.O. contact)	28	h	J2 pin 7 (R1300)
Upper Boom Retracted Switch (N.O. contact)	8	j	J2 pin 8 (R1300)
(not used)	—	k	—
Auger Overstow Switch (N.O. contact) Input	33	m	J2 pin 2 (R1300)
(spare switch input)	15	n	J2 pin 3 (R1300)
(spare switch input)	17	p	J2 pin 4 (R1300)
Boom Stowed Switch (N.O. Contact) Input	11	q	J2 pin 5 (R1300)
+5V Power for N.O. Switches	42	r	J2 pin 1 (R1300)
+5V for Proportional Pressure and Angle Sensors	34	s	J3 pin 1 (R1300)
Angle Sensor Input (-20.00° = 0.2V, +73.12° = 5.0V)	16	t	J3 pin 3 (R1300)
Lift Cylinder Piston-Side Pressure Sensor Input (0 PSI = 0.5V, 3000 PSI = 4.5V)	10	u	J3 pin 4 (R1300)

Lift Cylinder Rod-Side Pressure Sensor Input (0 PSI = 0.5V, 3000 PSI = 4.5V)	19	v	J3 pin 5 (R1300)
Ground for Proportional Pressure and Angle Sensors	35	w	J3 pin 6 (R1300)
(spare 0-5V proportional input)	—	x	J40 pin 2 (R1300)
(spare 0-5V proportional input)	—	y	J40 pin 3 (R1300)
(spare 0-5V proportional input)	—	z	J40 pin 4 (R1300)
(spare 0-5V proportional input)	18	AA	J40 pin 5 (R1300)
(spare pulse input)	36	AB	P1 (S20)
(spare pulse input)	41	AC	P2 (S20)
Turret Brake Release	37	AD	O7 (S20)
(not available)	40	AE	O8 (S20)

There are two separate power (+12V) and ground pins on the Main Connector. If you are using the old-style Output Cable or are making your own wire harness, the two ground pins (A and AF) should be connected to a good ground point at the battery or on the chassis. The two power pins (AG and B) should be connected to a good switched source, usually at the vehicle's PTO switch. While the Controller/Receiver contains internal fusing, it is highly recommended that in-line fuses be used to protect the wiring harness in case of short circuits; **use a 3A fuse for pin AG, and a 15A fuse for pin B.**

The Dump Valve Output (pin C) is a safety feature, and must be used to control a dump valve in the hydraulic pressure circuit. **Whenever this output becomes de-energized, the dump valve must divert the hydraulic flow back to tank** so that all hydraulically-powered movements stop. Only when this output is energized (driving +12V out) should the machine have hydraulic power.

The rest of the output functions except for the Electronic Throttle Output (pin e) are designed to drive either proportional or on/off solenoids at up to 3A each. Note that the total simultaneous load must not, of course, exceed the ratings of the power fuses (both inside the Controller/Receiver and your harness fuses). As the power distribution is complex, please contact OMNEX for information before changing the fuse ratings from their original values.

To control the engine throttle, use pin e for electronic throttles which take 0 to 5V, or wire pins b and c to direction-control relays for motor-driven throttles.

The Switch Inputs (pins m, n, p and q) are best switched to the +5V Power supplied from pin r, although they will work fine if switched to +12V. The +5V from pin r is preferred because it is already protected against short circuits. Do not feed +12V back into pin r.

**The proportional sensors must be powered from pin s (+5V) and pin w (ground).** Do not power them from +12V or any other ground.

**T47 Cable Control / Override Panel Connector:**

Function	Wire #	16-pin (24-5S) M.S. Pin	Board References
Ground	14	A	J15 (R1300), J3 (S20)
Power to T47	13	B	J41 (R1300)
Wired Remote Interface A	4	C	J1 pin 5 (R1300), CN4 pin 4 (S20)
Wired Remote Interface B	5	D	J1 pin 2 (R1300), CN4 pin 3 (S20)
E-Stop A	11	E	J41 (R1300)
E-Stop B	15	F	CN8 pin 8 (S20)
T47 ON Switch / Override Panel ENABLE Button	6	G	CN8 pin 4 (S20), CN3 pin 2 (S20), J2 pin 9 (R1300)
Ground	10	H	J15 (R1300), J3 (S20)
Override Panel Boom Rotate CCW	3	J	J10 pin 2 (R1300)
Override Panel Boom Rotate CW	1	K	J10 pin 3 (R1300)
Override Panel Intermediate Boom EXTEND	16	L	J10 pin 4 (R1300)
Override Panel Intermediate Boom RETRACT	2	M	J10 pin 5 (R1300)
Override Panel Upper Boom EXTEND	9	N	J10 pin 6 (R1300)
Override Panel Upper Boom RETRACT	17	P	J10 pin 7 (R1300)
Override Panel Lower Boom LOWER	8	R	J10 pin 8 (R1300)
Override Panel Lower Boom RAISE	7	S	J10 pin 9 (R1300)

In systems which include a T47 Cable Remote, the 16-pin connector is used for connection to the T47. However, in T45-only systems, a truck-mounted Emergency Override Panel must be provided; use either the old-style Emergency Override Panel Interface Cable or the new Custom Emergency Override Panel Harness to make connections from the 16-pin connector to this Panel. **The Emergency Override Panel must provide a normally-closed Emergency-Stop button across pins E and F.** The emergency-stop circuit must be closed to operate the machine. **The Emergency Override Panel must also provide a momentary, normally-open contact between pin B and pin G; this is the override button which the operator must press and hold to override the T45 Radio Transmitter.** Pin B is also the common to all the override switches (pins J through S). Pins C and D are not used for the Emergency Override Panel.

## 5. Fuses, Configuration Jumpers

The R1300+ and S20 circuit boards have a number of fuses and configuration jumpers which must be specific values for operation.

### 5.1. R1300 Board

F2 = 10A

F3 = 15A

F4 = 1A

F5 = (omit)

JP1 (MAIN BYPASS) = OFF

JP4 (RADIO STATUS) = OFF

JP2 (INPUTS 1) = GND

JP3 (INPUTS 2) = GND

J25/J29/J34 = (no jumper installed)

J26 (PWM PWR) jumpered to J22

J28 (OUT PWR) jumpered to J23

J27 (DIGITAL PWR) jumpered to J24

SW1 = (all positions OFF)

SW2 = (all positions OFF)

### 5.2. S20 Board

F4 = 10A

F5 = 1A

F6 = 1A

## 6. Setting Up the Radio Receiver

If you have purchased the optional Radio Transmitter and Receiver, you will need to verify that the Radio Receiver is set up to respond to your particular Radio Transmitter. This section describes how to set the configuration switches (see Figure 3) on the front of the DEX-900 Radio Receiver (mounted to the S20 Board inside the enclosure lid).



Figure 3 Radio Receiver

### 6.1. Unique Identifier (Radio ID)

Each T45 Radio Transmitter is identified by a unique Radio ID. The DEX-900 in your Receiver must be set up to match the ID of your transmitter. On the back plate (to which the metal guard is attached) is affixed a serial number and ID Code label, an example of which is shown in Figure 4. The ID code consists of two parts, SW 1 and SW 2, corresponding to switch banks labelled “ID” 1 through 8 (SW 1) and 9 through 16 (SW 2) on the REX-900.

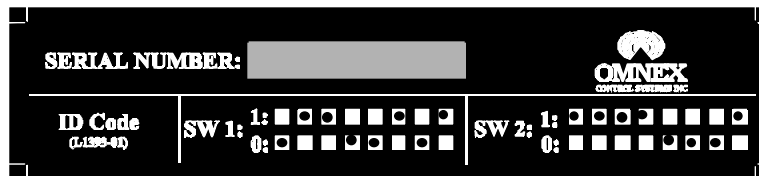

Figure 4 Radio Transmitter ID Label

The ID Code is punched as holes in the label, with the position of the hole indicating the position of each of the small switch handles on the DEX-900. Left to right corresponds to 1 through 8, and 9 through 16. On the label, “1” means ON and “0” means OFF. On the DEX-900, ON is towards the ANTENNA connector (as marked on each bank of switches), and OFF is towards the EXPANSION connector. Thus, to match the DEX-900 to the transmitter ID code given in the example label of Figure 4, you must

set switches 1 through 8 to OFF, ON, ON, OFF, OFF, ON, OFF, ON, and switches 9 through 16 to ON, ON, ON, ON, OFF, OFF, OFF, ON.

## **6.2. No-Link Data Mode**

The last bank of switches (“MODE”) on the DEX-900 is used to select various features on DEX-900. **For the Versalift Controller/Receiver, only position 5 should be ON.** This sets the DEX-900 to clear all its output data whenever there is no link or signal from the Radio Transmitter of the right ID.

## **6.3. Changing Switch Settings**

To change the switch settings, use a ballpoint pen or small screwdriver to move the switch levers. When you have set the levers to the right positions, turn the system power off (usually by shutting off the vehicle’s PTO switch) and back on again. The DEX-900 will take about 5 seconds to process your changes and then turn on its red ON lamp. **You must switch the power off and on whenever you change the DEX-900 switches, for the changes to take effect.**

# 7. Operations

This chapter briefly describes how to operate the Digger Derrick Control System. These instructions are intended to give you an understanding of basic operating principles; this is not a complete Operator's Manual. Once installation has been completed and checked, we recommend that you read this section carefully and operate the system to become accustomed to the controls.

## 7.1. Receiver/Controller

The Receiver/Controller does not contain an on/off switch. It is functional as soon as power is applied; power should be switched through an external switch, such as the vehicle's PTO switch.

### 7.1.1. Error Codes

The Receiver/Controller constantly monitors its safety systems. If a fault is detected, the Receiver/Controller will disable all control functions and begin flashing all of the VALUE lights in its Configuration Panel (see Figure 6) together with one of the numbered OUTPUT lights. The codes are as follows:

OUTPUT Light Flashing	Fault Indicated and Remedy
1_	One or both power relay contacts have welded closed. Replace both relays if they are the plug-in types; if not, the R1300+ board must be replaced.
2_	DEX-900 receiver stop-circuitry fault. Replace the DEX-900.

## 7.2. T45 Radio Transmitter

A description of transmitter operation follows.





### 7.2.1. Switching The Transmitter ON and OFF

The Versalift T45 Radio Transmitter has three LED lights to indicate its operating status, and a toggle switch to turn it on and off. It has built-in safety features to both protect you against unexpected movement of the controlled machine, and self-check its emergency stop circuit, when powering up. The operation of its status lights and power-on sequence is as follows:

To switch ON the transmitter:

1. Move the POWER switch to the ON position. The red  light will flash to indicate you must test the EMERGENCY STOP button.



2. The EMERGENCY STOP button test is two-part; the transmitter needs to see both states (pressed and released) of the button before it will allow you to operate. If the  light is flashing slowly, press the EMERGENCY STOP button. If the  light is flashing quickly, release the EMERGENCY STOP button. When the test is done, the button will be released.
3. The transmitter now checks to ensure that all switches and joysticks are in their “off” or “neutral” positions. If they are not, the green  (transmit) light and red  lights will flash together to indicate that you must switch off any functions which are on.
4. During normal operation, the green  light is on solid if no functions are switched on, and flashes if one or more functions are active.

***Be sure to switch off the transmitter when you are finished operating. Besides depleting the battery, an active, unattended transmitter is a safety hazard!***

### **7.2.2. Operator Controls:**

Once the transmitter is switched on and the green  light is on, all joysticks and toggle switches are active. The label indicates which machine functions are affected by each control. *To operate the dual-axis joystick functions or the centre paddle, you must press and hold one of the joystick deadman triggers.*

The DIGGER SHIFT function behaves slightly differently depending on whether you have a Two-Speed digger transmission or a Hydrasync digger. With a Hydrasync digger, you can shift “on the fly” and the shift occurs immediately when you activate DIGGER SHIFT (the Control System will toggle between HIGH and LOW speed). With a Two-Speed digger, activating DIGGER SHIFT will start an automatic 3-second shift sequence: The digger motor is stopped (if it is moving) for 1 second, a shift command is applied to the transmission for 1 second, and another 1-second delay occurs before the digger motor can be restarted. You do *not* need to hold the toggle switch for the entire sequence. Thus, you can be digging with the DIG/CLEAN paddle, toggle DIGGER SHIFT and the auger will automatically stop, shift, and resume with you having to let go of the DIG/CLEAN paddle.

### **7.2.3. Tilt Failsafe**

The transmitter is equipped with a tilt sensor which automatically engages the EMERGENCY STOP if the transmitter is tipped more than 90° from its normal horizontal operating position. This is a failsafe mechanism which protects the operator in case he or she falls or is struck by the machine itself. To resume operation from a tilt condition, press and release the EMERGENCY STOP button after righting the transmitter.

### 7.2.4. Low Battery Indicator

The  (battery) light is the “low battery” indicator. When the battery voltage is acceptable, the lamp will be off. If the voltage becomes too low, the lamp will begin to blink and the battery should be recharged, or replaced, as soon as possible. The control system will not become erratic with a low battery; it will simply cease to operate when the voltage falls below the minimum operating level.

### 7.2.5. Battery Charging and Replacement

The transmitter is powered by a Makita® 9.6V rechargeable power tool battery, and a standard Makita charger has been supplied with the system. Please follow the instructions included with the charger. To remove the battery from the transmitter, grasp the lip on the battery door and pull it down and out to open the door. Tilt the case to allow the battery to slide out. The battery is keyed to prevent incorrect installation (see Figure 5 below).

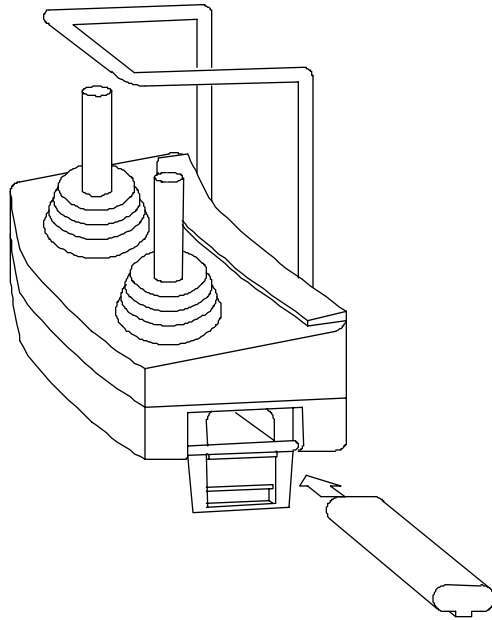



**Figure 5** Battery Replacement

### 7.2.6. Transmitter Light Summary

The following table describes all the conditions indicated by various states of the three transmitter lights. Note that the transmitter performs some self-diagnostics, and can indicate joystick and radio failures in addition to the “usual” operating status.

Legend: ● = LED on, ⊙ = LED flashing slowly, ★ = LED flashing quickly,  
○ = LED off, N/A = Not Applicable

 LED	 LED	STOP LED	Description	Action Required
○	○	○	Battery Dead; Power Off	Charge Battery; Turn Power On

○	○	⊙	E-Stop Test	Press E-STOP Button
○	○	*	E-Stop Test Part two	Release E-STOP Button
N/A	⊙	⊙	Functions not all off on EMERGENCY STOP release	Set all functions off
N/A	●	○	All Okay, all functions off	OK, continue as required
N/A	⊙	○	All Okay, 1+ functions on	OK, continue as required
N/A	○/⊙	●	Emergency Stop	E-STOP Button Pressed
⊙	N/A	N/A	Low Battery	Replace/Recharge Battery
⊙	⊙	*	Module failure: Joystick	Cycle Power--if not remedied, call service
⊙	*	⊙	Module failure: Radio	Cycle Power--if not remedied, call service

### 7.2.7. Numeric Display

The transmitter contains a three-digit numeric display to further indicate operating status. It can display numbers between 0.0 and 99.9, and is lighted for night viewing. There are several quantities that the display can show, indicated by “pointers” to three marks (LOAD %, BOOM ANGLE, DIAG) at the right edge of the display:

Mark Pointed To	Quantity Shown
LOAD %	Percentage of allowable boom load.
BOOM ANGLE	The absolute value of the boom angle, in degrees.
DIAG	The voltage, 0.0 to 5.0, at the piston-side pressure sensor.
BOOM ANGLE and DIAG2	The voltage, 0.0 to 5.0, at the rod-side pressure sensor.
(none)	This special mode shows the Boom Derating Factor being adjusted and will only appear in Factory Setup mode. Please see <b>9. Factory Parameters</b> for more information.

To change between these displays, press the DISPLAY button. The display will always start at LOAD % after releasing the transmitter’s EMERGENCY STOP.

The display will only work when the transmitter is switched on and its EMERGENCY STOP is released (the  light must not be on or flashing); otherwise, the display will show three dashes (“- - -”) in place of numbers. If the T47 Cable Remote is plugged in and switched on, the display on the T45 Transmitter will stop working and the information will be displayed on the T47’s display instead.

The display in the T45 will operate within a 100-foot (approximate) radius of the Receiver/Controller’s antenna; however, the remote control of the machine will operate much farther. Should the display stop working because you are too far from the machine, you can still safely operate the controls but you will not be able to read the status information.

### **7.3. T47 Cable Remote**

If you have purchased the optional T47 Cable Remote, you may operate the Digger Derrick Control System with all of the electronic safety features afforded with the Radio Transmitter, but via a hardwire (cable). To activate the T47 Cable Remote, release the red Emergency Stop button and switch on the T47's POWER switch—the control of the machine is now taken away from the Radio Transmitter and given to the T47 Cable Remote. All control functions operate as in the T45 Transmitter.

Note that for safety, the Cable Remote's Emergency Stop button must be released even when operating from the Radio Transmitter; this allows someone to stop the machine at the Cable Remote.

The numeric display in the T47 Cable Remote does not have any distance limitation as in the T45. The display will work as long as the T47's cable is connected, the T47's POWER switch is turned on and the EMERGENCY STOP is released.

### **7.4. Emergency Override Panel**

If you have not purchased the T47 Cable Remote, you must have an Emergency Override Panel connected in place of the Cable Remote. To operate from the Emergency Override Panel, make sure the Emergency Stop button on the Panel is released and press and hold the ENABLE button while operating the toggle switches on the Panel.

## 8. Proportional Drive Adjustments

Each proportional valve output can be adjusted to match the characteristics of the individual valve. There are proportional functions which come out of the R1300 circuit board, as well as out of the S20.

The proportional outputs from the S20 are numbered O1 through O16, and the proportional outputs from the R1300 are numbered 1+ through 6-; their assigned functions are indicated in the table below.

Proportional Output	Set-Up Panel Indicator	Function
1+ (R1300)	Solid 1+	Winch DOWN
1- (R1300)	Solid 1-	Winch UP
2+ (R1300)	Solid 2+	Digger DIG
2- (R1300)	Solid 2-	Digger CLEAN
3+ (R1300)	Solid 3+	Lower Boom LOWER
3- (R1300)	Solid 3-	Lower Boom RAISE
4+ (R1300)	Solid 4+	Intermediate Boom EXTEND
4- (R1300)	Solid 4-	Intermediate Boom RETRACT
5+ (R1300)	Solid 5+	Upper Boom EXTEND
5- (R1300)	Solid 5-	Upper Boom RETRACT
6+ (R1300)	Solid 6+	Pole Guide/Platform LOWER
6- (R1300)	Solid 6-	Pole Guide/Platform RAISE
O1 (S20)	Flashing 1+	Boom Rotate CCW
O2 (S20)	Flashing 1-	Boom Rotate CW
O3 (S20)	Flashing 2+	Pole Guide/Platform OPEN
O4 (S20)	Flashing 2-	Pole Guide/Platform CLOSE
O5 (S20)	Flashing 3+	Digger Shift HIGH (normally set for on/off behaviour)
O6 (S20)	Flashing 3-	Digger Shift LOW (normally set for on/off behaviour)
O7 (S20)	Flashing 4+	(Do not adjust—used for Turret Brake Release)
O8 (S20)	Flashing 4-	(spare proportional output)
O9 (S20)	Flashing 5+	Electronic Throttle (0 to 5V output PWM/V Board)
O10 (S20)	Flashing 5-	(not used)

O11 (S20)	Flashing 6+	(not used)
O12 (S20)	Flashing 6-	(not used)
O13 (S20)	Solid 1	(not used)
O14 (S20)	Solid 2	(not used)
O15 (S20)	Solid 3	(not used)
O16 (S20)	Solid 4	(not used)

Built-in to the R1300 is a Set-Up Panel (see Figure 6) consisting of three columns of indicator lights, seven push buttons, and a socket for a plug-in “key”. As shown in the diagram below, there are five configurable parameters (centre column of lights) for each proportional (pulse-width modulation, PWM) output: Threshold, Start PWM, Max PWM, Ramp Up, and Ramp Down.

The Set-Up Panel has “Output” lights 1+ to 6- which correspond directly to the proportional outputs of the R1300. For adjustment of the proportional outputs of the S20, the Output lights are re-used as per the “Set-Up Panel Indicator” column in the above table.

The 12 R1300 proportional outputs are indicated by the lights in the “Output” column as follows: When the “1\_” and “+” lights are solidly on, the 1+ parameter is being output is being adjusted. The “1\_” and “-” lights indicate 1-, and so on. The table above lists these as “Solid 1+” through “Solid 6-”.

The first 12 S20 proportional outputs (O1 through O12) are indicated by *flashing* “1+” through *flashing* “6-”. The table above lists these as “Flashing 1+” through “Flashing 6-”.

The last 4 outputs (O13 through O16) of the S20 are indicated by the “1\_” through “4\_” lights solidly on with both the “+” and “-” lights off. The table above lists these as “Solid 1” through “Solid 4”.

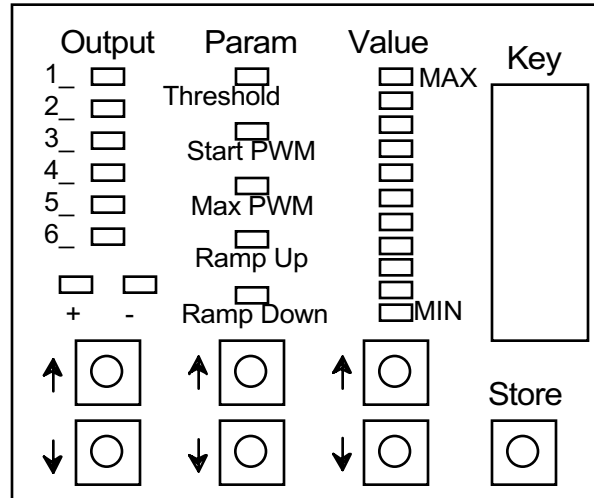

**Figure 6** R1300 Set-Up Panel

The Ramp parameters control how fast the output builds up or down to the final value according to a first-order difference equation. The separate Ramp Up and Ramp Down time constants allow you to tune the valve response for smooth, non-jerky actuation. The Threshold, Start PWM, and Max PWM parameters control the transfer-function from input (joystick position) to PWM-output value, as shown in Figure 7. The joystick position can go from 0 to 127. The threshold is simply the deadband beyond which the joystick must move in order to actuate the PWM output. The PWM output starts at Start PWM as soon as the joystick has exceeded the threshold, and maps linearly with joystick position up to Max PWM.

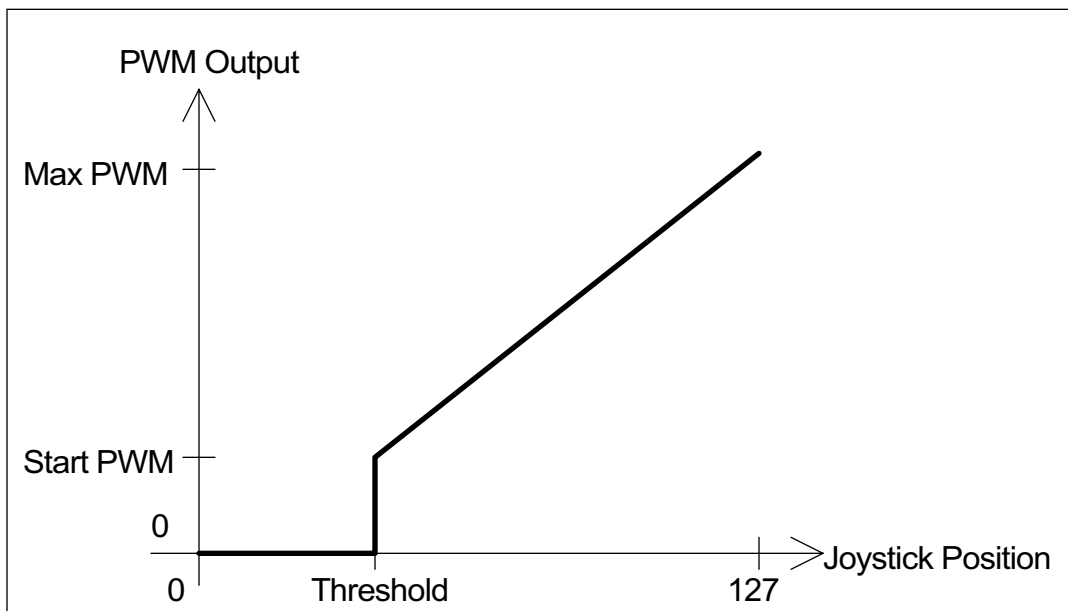

**Figure 7** Proportional (PWM) Output Function

In order to customize various parameters for the PWM outputs, the configuration panel must be “enabled” by plugging in the Factory Key or User Key (supplied); you will then be in Proportional Drive Setup mode. The display will initially be displaying “Output” 1 +, no “Param” lights will be illuminated, and the “Value” lights will be displaying the Start PWM and Max PWM as solid lights, and the actual function output value as a flashing light. The flashing light will move as the corresponding joystick is moved, and you will also see the green light next to the 1+ output on J6 go brighter and dimmer.

To select the output pin you want to change parameters for, press the buttons under the “Output” lights. To change a parameter, press the buttons under the “Param” lights until the desired parameter is lit up (Threshold, Start PWM, Max PWM, Ramp Up, Ramp Down). The “Value” lights will now indicate where the selected parameter is currently set, in relation to the MAX and MIN values allowed for that particular parameter (see table below). Press the buttons below the “Value” lights to raise or lower the parameter; if the value of the parameter is “in between” two lights, the two adjacent lights will both be on at once, each with relative brightness corresponding to how far in between the two lights the value is. To change a parameter a long way, press and hold the button and it will auto-repeat as on a computer keyboard.

The table below indicates the minimum, maximum, and increment values for each of the proportional drive adjustments. The default values for each parameter are specific to each proportional output and are not listed.

Parameter	Minimum	Maximum	Increment
Threshold	0 (out of 127)	40 (out of 127)	1
Start PWM	0%	lesser of 100% and Max PWM Minimum setting	1%
Max PWM	greater of 0% and Start PWM Maximum setting	100%	1%
Ramp Up	0 ms	1054 ms	34 ms
Ramp Down	0 ms	1054 ms	34 ms



As you are adjusting any of the parameters, you can “try” the new setting right away by moving the joystick and watching the hydraulic/pneumatic response. A very good way to tune the proportional parameters is to have someone watch the override handles on the hydraulic valves (or the cylinder or bellows in a pneumatic system) as you operate the joystick from “just-on” to “full-on”; for best metering action, adjust the Start PWM and Max PWM such that the whole travel of the joystick corresponds to full travel of the override handle, with no “dead” region at the start or end of the joystick travel. **Note: It is very important that the proportional drive frequency be correct for the type of valve installed in your system. Please see the next chapter for information on how to set the drive frequency, and make sure it is correct before attempting to adjust the PWM output parameters.**

When you are happy with the way the parameters are set up, press the “Store” button. All of the lights will come on to indicate that the new parameters have been stored. If you wish not to save the changes you have made, simply unplug the key. Then, you can plug the key back in and start again from the original settings. If you have stored a set of new parameters which are so far off from values which the machine will operate with, press and *hold* the “Store” button until all the lights begin to flash. Release the button and all of the Proportional Drive parameters will be reset to factory-default values.

**Important:** The key should not be left plugged in after you have completed the set-up procedure. Leaving the key in may allow someone to change the parameters accidentally, as well as allow the long-term vibration of the vehicle to damage the key.

# 9. Factory Parameters

The Digger Derrick Control System has 10 “Factory Parameters” which may be configured to match the model of valves installed in the machine, and to set the load limit. They are called “Factory Parameters” because they are usually set at your factory before the machine is shipped to the end customer. In the Digger Derrick application, the first 4 Factory Parameters are PWM drive frequencies for the various “banks” of proportional outputs, and the rest of the Factory Parameters set boom load moment limits and speeds of special functions.

In the general discussion below, reference is made to “up to 48 Factory Parameters”, which means 38 more parameters may be added in the future, if required.

## 9.1. Types of Factory Parameters

There are only two types of factory parameters. The first type of parameter is a “multiple-choice” selection; the “PWM Drive Frequency for S20 Proportional Outputs O1 through O8” parameter is an example of a multiple-choice parameter—you set it by selecting one of 5 different frequencies.

The second type of factory parameter is a “variable-value” adjustment with a minimum and maximum value. Examples of such a parameter are the Boom Derating factors; you set between 20% and 150% in 2% increments.

## 9.2. Changing the Factory Parameters

To change or view the Factory Parameters, use the following procedure:

1. Plug the Factory Key (the User Key will not allow you to enter Factory Setup Mode) into the R1300 Controller board’s Set-up Panel; you will be in Proportional Drive Setup mode. Enter Factory Setup mode by simultaneously pressing the two lower left-hand buttons; the light display will change.
2. There can be up to 48 Factory Parameters. Pressing the up and down buttons at the bottom of the “Output” column changes the parameter you are accessing. The first 12 are indicated by the lights in the “Output” column as follows: When the “1\_” and “+” lights are on, the first parameter is being accessed. The “1\_” and “-” lights indicate the second parameter, “2+” indicates the third, “2-” indicates the fourth, etc. down to “6-” which is the 12th parameter. The next 12 parameters are indicated by *flashing* “1+” through *flashing* “6-”.

The next 6 parameters are indicated by the “1\_” through “6\_” lights solidly on with both the “+” and “-” lights off. The next 6 are indicated by “1\_” through “6\_” solidly on with both the “+” and “-” lights on.

The next 6 parameters are indicated by flashing “1\_” through flashing “6\_” with both the “+” and “-” lights off. The last 6 parameters are indicated by flashing “1\_” through flashing “6\_” with both the “+” and “-” lights also flashing.

3. To change or view a particular Factory Parameter, press the up or down Output buttons until you reach the desired parameter (see table below). Note that if you press the up button when you are already at the “top” (parameter 1, solid “1+”), the display will “wrap around” to the last parameter (parameter 48, flashing “6±”). A similar wrap-around happens when you press the down button when you are already at the last parameter.
4. The display will show one light on in the “Param” column if the selected parameter is a “multiple-choice” type, or one or two lights in the “Value” bar graph if the parameter is a “variable-value” type. You change the multiple-choice selection using the buttons under the “Param” lights, and the variable-value using the buttons under the “Value” lights. For multiple-choice parameters, the top Param light (“Threshold”) through the bottom light (“Ramp Down”) are referred to in the table as choices “A” through “E”.

When changing a variable-value parameter, note that the top Value light (“MAX”) corresponds to the maximum value allowed for that parameter (see table below), and the bottom (“MIN”) corresponds to the minimum value allowed. Each single press of the Value up or down buttons will change the parameter by the increment value for that parameter. Holding down either button will cause it to automatically repeat, and is useful when you need to change a value a long way from where it is.

If you are adjusting either of the Boom Derating Factors, the numeric display on the T45 or T47 will show the value (in percent) of the parameter you are adjusting, with no pointers (LOAD %, DIAG1, DIAG2) showing.

5. When you are done changing the parameters, press the Store button to save the new Factory Parameters. If you do not want to save your changes, remove the Factory Key. If you want to restore the Factory Parameters to the preprogrammed factory-default settings, press and hold the Store button until all the lights begin flashing; only the Factory Parameters are affected--the Proportional Drive Settings can only be reset by holding the Store button in Proportional Drive Setup Mode.
6. You can now remove the Factory Key or simultaneously press the two lower-left hand buttons again to get back to Proportional Drive Setup mode.

### 9.3. List of Factory Parameters

The following table lists the Digger Derrick Control System Factory Parameters. For each parameter, the corresponding light display in the Output column is shown, together with the Minimum, Maximum, Adjustment Increment, and Default Value. The last two columns in the table indicate other adjustment restrictions for the parameter; some parameters may be constrained by the values of other parameters.

An explanation of the parameters whose function is not immediately obvious follows the table.

Parameter	Display	Type	Min.	Max.	Increment	Default	Cannot Go Below	Cannot Go Above
PWM Drive Frequency for R1300 Proportional Outputs 1+/- through 4+/-	Solid 1+	Mult.-Choice	A = 33 Hz B = 50 Hz C = 80 Hz D = 125 Hz E = 250 Hz			A	N/A	N/A
PWM Drive Frequency for R1300 Proportional Outputs 5+/- and 6+/-	Solid 1-	Mult.-Choice	A = 33 Hz B = 50 Hz C = 80 Hz D = 125 Hz E = 250 Hz			A	N/A	N/A
PWM Drive Frequency for S20 Proportional Outputs O1 through O8	Solid 2+	Mult.-Choice	A = 33 Hz B = 50 Hz C = 80 Hz D = 125 Hz E = 250 Hz			A	N/A	N/A
PWM Drive Frequency for S20 Proportional Outputs O9 through O16	Solid 2-	Mult.-Choice	A = 33 Hz B = 50 Hz C = 80 Hz D = 125 Hz E = 250 Hz			E	N/A	N/A
Boom Load Moment Limit	Solid 3+	Mult.-Choice	A = 2500000 inch-lbs			A	N/A	N/A
Boom Derating Factor, Ground Operation (%)	Solid 3-	Variable Value	20	150	2	84	N/A	N/A

Boom Derating Factor, Platform Operation (%)	Solid 4+	Variable Value	20	150	2	66	N/A	N/A
Emergency Override Panel Function Speed (%)	Solid 4-	Variable Value	5	100	5	25	N/A	N/A
Auger Shake Speed (%)	Solid 5+	Variable Value	5	100	5	100	N/A	N/A
Digger Transmission Type	Solid 5-	Mult.-Choice	A = Two-Speed B = Hydrasync			A	N/A	N/A

### **PWM Drive Frequency Parameters**

These 4 parameters allow you to use the Receiver/Controller in heterogeneous valve systems. Grouping valves requiring different drive frequencies into separate banks, you can provide each valve with the drive frequency most suited to it.

### **Boom Load Moment Limit**

This parameter allows you to select from up to five load moment limits, to match the exact model of digger derrick on which you are installing the Control System.

### **Boom Derating Factors**

These parameters are used to multiply (in percent) the **Boom Load Moment Limit** to determine the actual load limit for the boom. There are two separate factors; one is for ground operation and the other for platform operation.

When you are adjusting these parameters, the T45 or T47 numeric display will show the value (in percent) of the parameter you are adjusting, with no pointers (LOAD %, DIAG1, DIAG2) showing

### **Emergency Override Panel Function Speed**

This parameter determines the speed of the proportional functions when operated from the toggle switches on the Emergency Override Panel.

### **Auger Shake Speed**

This parameter determines the speed of the digger when operated from the Auger Shake toggle switch.

### **Digger Transmission Type**

This parameter is used to determine if the auger must be stopped while shifting speeds. Hydrasync diggers can be shifted “on the fly”, while two-speed diggers cannot. When the Two-Speed digger is selected, the DIGGER SHIFT functions will automatically stop the auger, perform a shift, and then restart the auger.

## 10. Warranty

**OMNEX Control Systems Inc.** (“OMNEX”) warrants, to the original purchaser, that the OMNEX Control System is free from defects in materials and workmanship, subject to normal use and service, for a period of ONE YEAR from the original date of delivery as evidenced by a copy of the sales invoice. This warranty covers parts (excluding crystals, parts subjected to unauthorized repair or modification, and wear and tear on switches, knobs, and joysticks) and labour.

OMNEX’s entire liability and your exclusive remedy shall be, at OMNEX’s option, either the repair or replacement of the OMNEX Control System, which must be returned with a copy of the original sales invoice to OMNEX freight prepaid. If failure resulted from accident, abuse or misapplication, OMNEX shall have no responsibility to repair or replace the Control System. Under no circumstances shall OMNEX be responsible for incidental or consequential damage or loss caused by defects in its products, whether such damage or loss occurs or is discovered before or after replacement or repair, and whether or not such damage may be caused by the negligence of OMNEX Control Systems Inc.

Neither OMNEX nor its Distributor shall be liable for any delay or failure in the performance of any of its obligations under this agreement caused by acts of God, strikes, other labour disturbances, embargoes, boycotts, shortage of parts or any cause beyond its reasonable control.