



# Test Report

For

**Applicant** : ZyXEL Communications Corporation  
**Equipment Type** : Wireless Lan Router / Lan Router  
**Model** : PRESTIGE 310, eSEC 312, PRESTIGE 316  
**FCC ID** : I88PRESTIGE316

**Report No.:** 008H037FI



# Test Report Certification

## QuieTek Corporation

No.75-1, Wang-Yeh Valley, Yung-Hsing, Chiung-Lin,  
Hsin-Chu County, Taiwan, R.O.C.  
Tel : 886-3-592-8858, Fax: 886-3-592-8859  
E-Mail : quietek@ms24.hinet.net

Accredited by NIST(NVLAP), VCCI, BSMI, DNV, TUV

Applicant : ZyXEL Communications Corporation  
Address : No.6, Innovation Rd II, Science-Based Industrial Park,  
Hsin-Chu, Taiwan, R.O.C.  
Equipment Type : Wireless Lan Router / Lan Router  
Model : PRESTIGE 310, eSEC 312, PRESTIGE 316  
FCC ID. : I88PRESTIGE316  
Measurement Standard : CISPR 22/1985  
Measurement Procedure : ANSI C63.4 /1992  
Operation Voltage : 120VAC/60Hz  
Classification : Class B  
Test Result : Complied  
Test Date : Aug.21, 2000  
Report No. : 008H037FI



The Test Results relate only to the samples tested.  
The test report shall not be reproduced except in full without the written approval of QuieTek Corporation.  
This report must not be used to claim product endorsement by NVLAP any agency of the U.S. Government

Documented by: Lisa Chen

Test Engineer: Warren Lin

Approved: Kevin Wang



# TABLE OF CONTENTS

Description	Page
<b>1. GENERAL INFORMATION .....</b>	<b>4</b>
1.1 EUT Description.....	4
1.2 Tested System Details.....	5
1.3 EUT Configuration.....	8
1.4 EUT Exercise Software.....	9
1.5 Test performed.....	9
1.6 Test Facility.....	10
<b>2. CONDUCTED EMISSION .....</b>	<b>11</b>
2.1 Test Equipment List.....	11
2.2 Test Setup .....	11
2.3 Limits.....	11
2.4 Test Procedure.....	12
2.5 Test Results .....	12
<b>3. RADIATED EMISSION .....</b>	<b>13</b>
3.1 Test Equipment .....	13
3.2 Test Setup .....	13
3.3 Limits.....	14
3.4 Test Procedure.....	14
3.5 Test Results .....	14
<b>4. EMI REDUCTION METHOD DURING COMPLIANCE TESTING .....</b>	<b>15</b>
<b>5. ATTACHMENT.....</b>	<b>16</b>
ATTACHMENT 1: SUMMARY OF TEST RESULTS	
ATTACHMENT 2: EUT TEST PHOTOGRAPHS	
ATTACHMENT 3: EUT DETAILED PHOTOGRAPHS	



# 1. General Information

## 1.1 EUT Description

Applicant : ZyXEL Communications Corporation

Address : No.6, Innovation Rd II, Science-Based Industrial Park, Hsin-Chu, Taiwan, R.O.C.

Equipment Type : Wireless Lan Router / Lan Router

Model : PRESTIGE 310, eSEC 312, PRESTIGE 316

FCC ID : I88PRESTIGE316

Operation Voltage : 120VAC/60Hz

CPU Speed : 10, 16, 20, 25MHz

Lan shielded cross over : 3m, 1pc

Lan shielded strait : 3m, 1pc

Y Type RS 232 Cable : Non-Shielded, 0.8m, 1pc

Wireless LAN PC Card : Z-Com, Inc., XI-300  
FCC ID:M4Y-XI-300

Power Adapter : ZyXEL, MW48-1601000UA  
Cable out: Non-Shielded, 1.5m

Remark : 1.This device a Wireless Lan Router / Lan Router.  
2.The different model name is for different brand, and the different between bridge and router is the operation software.  
3.The Wireless option is under ID M4Y-XI-300.  
4.QuieTek had verified all construction and function, then shown in this test report.

## 1.2 Tested System Details

The types for all equipment, plus descriptions of all cables used in the tested system (including inserted cards ) are:

### 1.2.1 Host Personal Computer

Model Number : P2L97  
Serial Number : 92M4Y00777  
FCC ID : DoC  
Manufacturer : ASUS  
Power Cord : Non-Shielded, 1.8m

### 1.2.2 Wireless Lan Router / Lan Router (EUT)

Model Number : PRESTIGE 310, eSEC 312, PRESTIGE 316  
Serial Number : N/A  
FCC ID : DoC  
Manufacturer : ZyXEL  
Lan shielded cross over : 3m, 1pc  
Lan shielded strait : 3m, 1pc  
Y Type RS 232 Cable : Non-Shielded, 0.8m, 1pc  
Wireless LAN PC Card : Z-Com, Inc., XI-300  
FCC ID:M4Y-XI-00  
Power Adapter : ZyXEL, MW48-1601000UA  
Cable out: Non-Shielded, 1.5m

### 1.2.3 Monitor

Model Number : CM752ET-311  
Serial Number : T8E004443  
FCC ID : DoC  
Manufacturer : HITACHI  
Data Cable : Shielded, 1.5m  
Power Cord : Shielded, 1.8m

### 1.2.4 Keyboard

Model Number : SK-2502  
Serial Number : M971237059  
FCC ID :GYUR41SK  
Manufacturer : HP

### 1.2.5 Modem

Model Number : 1414  
Serial Number : 980033032  
FCC ID : IFAXDM1414  
Manufacturer : ACEEX  
Data Cable : Shielded, 1.5m  
Power Adapter : ACCEX, SCP41-91000A  
Cable Output : Shielded, 1.5m



**1.2.6 Printer**  
Model Number : C2642A  
Serial Number : MY75J1D1D2  
FCC ID : B94C2642X  
Manufacturer : HP  
Data Cable : Shielded, 1.2m  
Power Adapter : NMB, C2175A  
Cable for AC IN: Non-Shielded, 0.7m  
Cable for AC Out: Non-Shielded, 1.5m

**1.2.7 Mouse**  
Model Number : M-S34  
Serial Number : LZB75078428  
FCC ID : DZL211029  
Manufacturer : HP  
Data Cable : Shielded, 1.8m

**1.2.8 Mouse**  
Model Number : M-UB48  
Serial Number : LTC74800118  
FCC ID : DZL211137  
Manufacturer : Logitech  
Data Cable : Shielded, 1.8m

**1.2.9 Mouse**  
Model Number : M-UB48  
Serial Number : LTC74800118  
FCC ID : DZL211137  
Manufacturer : Logitech  
Data Cable : Shielded, 1.8m

**1.2.10 LAN Cable: Shielded, 10m, 2 pcs**

**1.2.11 Y-Cable RS232: Non-Shielded, 1.0m**

## Partner PC System

### 1.2.12 Notebook PC

Model Number : 500  
Serial Number : 9145B0160C9100170EM  
Manufacturer : ACER  
FCC ID : DoC  
Power Cord : Non-shielded, 1.8m  
Power Adapter : DELTA, ADP-45GB  
Cable In: Non-shielded, 1.6m  
Cable Out: Non-shielded, 1.8m

### 1.2.13 Notebook PC

Model Number : Designote  
Serial Number : 061277  
Manufacturer : LEO  
FCC ID : DoC  
Power Adapter : LIEN, LE-9401B20  
Cable In: Non-shielded, 1.2m  
Cable Out: Non-shielded, 1.8m

### 1.2.14 Notebook PC

Model Number : 5023  
Serial Number : P7121005  
Manufacturer : Mictac  
FCC ID : DoC  
Power Cord : Non-Shielded, 1.8m  
Power Adapter : LP586-ADA  
Cable In: Non-shielded, 1.2m  
Cable Out: Non-shielded, 1.8m

### 1.3 EUT Configuration

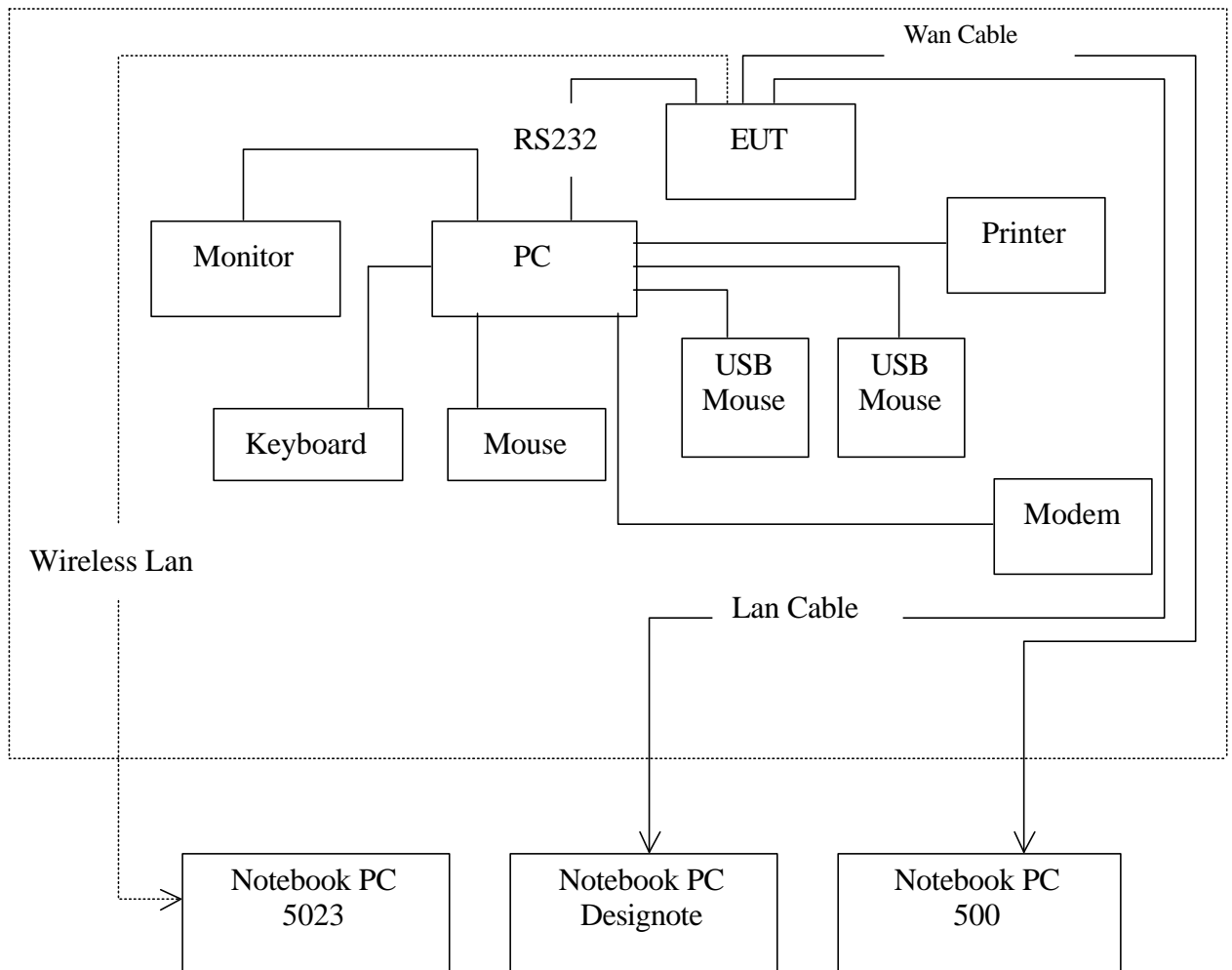



## 1.4 EUT Exercise Software

The EUT exercise program used during conducted testing was designed to exercise the EUT in a manner similar to a typical use. The exercise sequence is listed as below:

- 1.4.1 Setup the EUT and simulators as shown on 1.3.
- 1.4.2 Turn on the power of all equipment.
- 1.4.3 Boot the PC from Hard Disk .
- 1.4.4 Data will communicate between personal computer and partner notebook personal notebook through EUT.
- 1.4.5 The personal computer's and partner notebook personal notebook monitor will show the transmitting and receiving characteristics when the communication is success.
- 1.4.6 Printer and modem will keep at standby mode during Scanner operation.
- 1.4.7 Repeat the above procedure 1.4.4 to 1.4.7

## 1.5 Test performed

Conducted emissions were invested over the frequency range from **0.15MHz to 30MHz** using a receiver bandwidth of 9kHz.

Radiated emissions were invested over the frequency range from **30MHz to 1000MHz** using a receiver bandwidth of 120kHz. Radiated testing was performed at an antenna to EUT distance of 10 meters.

## 1.6 Test Facility

Ambient conditions in the laboratory:

Items	Required (IEC 68-1)	Actual
Temperature (°C)	15-35	20-35
Humidity (%RH)	25-75	50-65
Barometric pressure (mbar)	860-1060	950-1000

Site Description: November 3, 1998 File on  
Federal Communications Commission  
FCC Engineering Laboratory  
7435 Oakland Mills Road  
Columbia, MD 21046  
Reference 31040/SIT1300F2



September 30, 1998 Accreditation on NVLAP  
NVLAP Lab Code: 200347-0

February 23, 1999 Accreditation on DNV  
Statement No.: 413-99-LAB11



December 8, 1998 Registration on VCCI  
Registration No. for No.2 Shielded Room C-858  
Registration No. for No.1 Open Area Test Site R-823  
Registration No. for No.2 Open Area Test Site R-835



January 04, 1999 Accreditation on TÜV Rheinland  
Certificate No.: I9865712-9901



Name of firm : QuieTek Corporation

Site location : No.75-1, Wang-Yeh Valley, Yung-Hsing Tsuen,  
Chiung-Lin, Hsin-Chu County, Taiwan, R.O.C.

## 2. Conducted Emission

### 2.1 Test Equipment List

The following test equipment are used during the conducted emission test:

Item	Instrument	Manufacturer	Type No./Serial No	Last Cal.	Remark
1	Test Receiver	R & S	ESCS 30/825442/17	May, 2000	
2	L.I.S.N.	R & S	ESH3-Z5/825016/6	May, 2000	EUT
3	L.I.S.N.	Kyoritsu	KNW-407/8-1420-3	May, 2000	Peripherals
4	Pulse Limiter	R & S	ESH3-Z2	N/A	
5	N0.2 Shielded Room			N/A	

Note: All equipment upon which need to calibrated are with calibration period of 1 year.

### 2.2 Test Setup

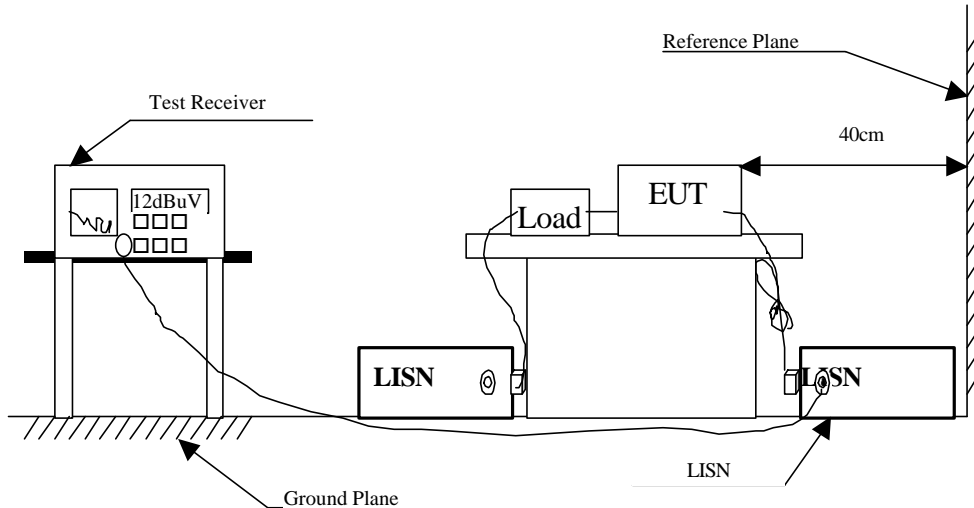

### 2.3 Limits

CISPR 22 Limits (dBuV)					FCC Part 15 Subpart B (dBuV)				
Frequency MHz	Class A		Class B		Frequency MHz	Class A		Class B	
	QP	AV	QP	AV		uV	dBuV	uV	dBuV
0.15 - 0.50	79	66	66-56	56-46	0.45-1.705	1000	60.0	250	48.0
0.50-5.0	73	60	56	46	1.705-30	3000	69.5	250	48.0
5.0 - 30	73	60	60	50					

Remarks : In the above table, the tighter limit applies at the band edges.

## 2.4 Test Procedure

The EUT and simulators are connected to the main power through a line impedance stabilization network (L.I.S.N.). This provides a 50 ohm /50uH coupling impedance for the measuring equipment. The peripheral devices are also connected to the main power through a LISN that provides a 50ohm/50uH coupling impedance with 50ohm termination. (Please refers to the block diagram of the test setup and photographs.)

Both sides of A.C. line are checked for maximum conducted interference. In order to find the maximum emission, the relative positions of equipment and all of the interface cables must be changed according to ANSI C63.4 /1992 on conducted measurement.

The bandwidth of the field strength meter (R & S Test Receiver ESCS 30) is set at 9kHz.

## 2.5 Test Results

The conducted emission from the EUT is measured and shown in attachment 1 of test report. The acceptance criterion was met and the EUT passed the test.

### 3. Radiated Emission

#### 3.1 Test Equipment

The following test equipment are used during the radiated emission test:

Test Site		Equipment	Manufacturer	Model No./Serial No.	Last Cal.
Site # 1	X	Test Receiver	R & S	ESCS 30 / 825442/14	May, 2000
		Spectrum Analyzer	Advantest	R3261C / 71720140	May, 2000
		Pre-Amplifier	HP	8447D/3307A01812	May, 2000
	X	Bilog Antenna	Chase	CBL6112B / 12452	Sep., 1999
	X	Horn Antenna	EM	EM6917 / 103325	May, 2000
Site # 2	X	Test Receiver	R & S	ESCS 30 / 825442/17	May, 2000
		Spectrum Analyzer	Advantest	R3261C / 71720609	May, 2000
		Pre-Amplifier	HP	8447D/3307A01814	May, 2000
	X	Bilog Antenna	Chase	CBL6112B / 2455	Sep., 1999
	X	Horn Antenna	EM	EM6917 / 103325	May, 2000

- Note:
1. All equipment upon which need to calibrated are with calibration period of 1 year.
  - 2.. Mark "X" test instruments are used to measure the final test results.

#### 3.2 Test Setup

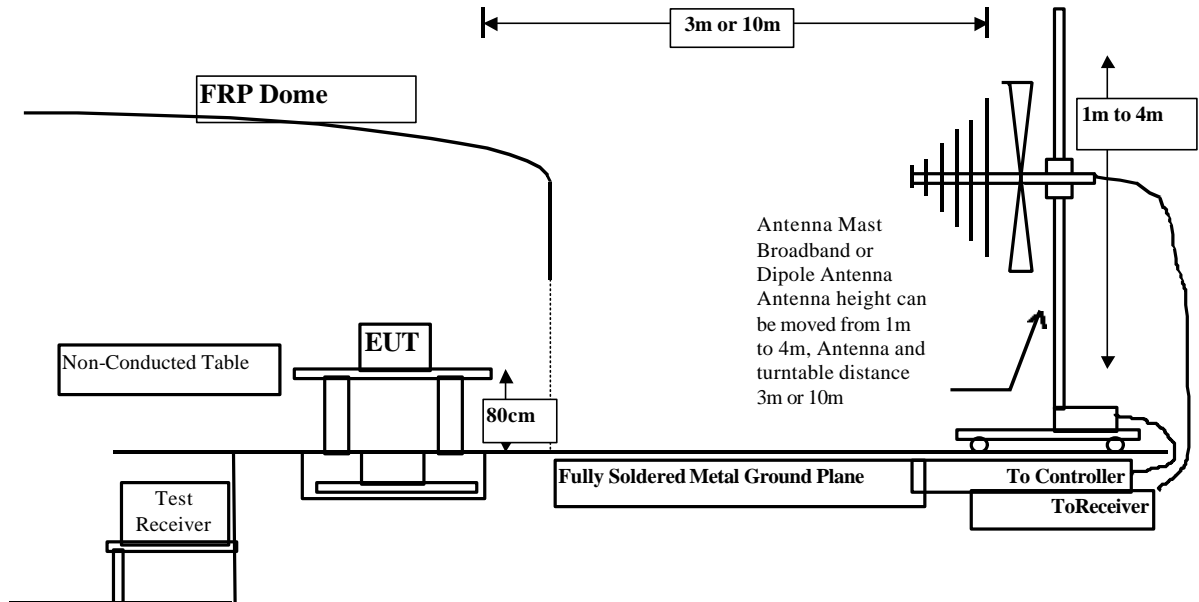

### 3.3 Limits

CISPR 22					FCC Part 15 Subpart B				
Frequency	Class A		Class B		Frequency	Class A		Class B	
MHz	Distance (m)	dBuV/m	Distance (m)	dBuV/m		UV/m	DBuV/m	UV/m	DBuV/m
30 – 230	10	40	10	30	30 – 88	90	39	100	40.0
230 – 1000	10	47	10	37	88 – 216	150	43.5	150	43.5
					216 – 960	210	46.5	200	46.0
					960 - 2000	300	49.5	500	54.0

Remark: 1. The tighter limit shall apply at the edge between two frequency bands.

2. Distance refers to the distance in meters between the measuring instrument antenna and the closed point of any part of the device or system.

3. RF Line Voltage (dBuV/m) = 20 log RF Line Voltage (uV/m)

### 3.4 Test Procedure

The EUT and its simulators are placed on a turn table which is 0.8 meter above ground. The turn table can rotate 360 degrees to determine the position of the maximum emission level. The EUT was positioned such that the distance from antenna to the EUT was 10 meters . The antenna can move up and down between 1 meter and 4 meters to find out the maximum emission level.

Both horizontal and vertical polarization of the antenna are set on measurement. In order to find the maximum emission, all of the interface cables must be manipulated according to ANSI C63.4 /1992 on radiated measurement.

The bandwidth below 1GHz setting on the field strength meter (R&S Test Receiver ESCS 30 ) is 120 kHz.

### 3.5 Test Results

The radiated emission from the EUT is measured and shown in attachment 1 of test report.

The acceptance criterion was met and the EUT passed the test.

#### 4. EMI Reduction Method During Compliance Testing

No modification was made during testing.



## 5. Attachment

Attachment 1: Summary of Test Results	Number of Pages: 5
Attachment 2: EUT Test Photographs	Number of Pages: 2
Attachment 3: EUT Detailed Photographs	Number of Pages: 7



## Attachment 1 : Summary of Test Results

The test results in the emission and immunity were performed according to the requirements of measurement standard and process. QuieTek Corporation is assumed full responsibility for the accuracy and completeness of these measurements. The test data of the emission and immunity are listed as the attached data.

All the tests were carried out with the EUT in normal operation, which was defined as:

Mode 1: 100Mbps

### **The EUT passed all the tests.**

The uncertainty is calculated in accordance with NAMAS NIS 81, The total uncertainty for this test is as follows:

#### ➤ **Emission Test**

- Uncertainty in the Conducted Emission Test:  $< \pm 2.0$  dB
- Uncertainty in the field strength measured:  $< \pm 4.0$  dB

## CONDUCTED EMISSION DATA

Date of Test : Aug.21, 2000 EUT : Wireless Lan Router / Lan Router  
 Test Mode : Mode 1 Detect Mode : Quasi-Peak & Average

Frequency	Cable Loss	LISN Factor	Reading Level	Measurement Level	Limits
MHz	dB	dB	Line1	Line1	dBuV
			dBuV	dBuV	dBuV
0.171	0.01	0.10	47.00	47.11	64.94
0.299	0.04	0.10	42.89	43.03	60.28
0.455	0.06	0.10	40.89	41.05	56.79
*0.455	0.06	0.10	41.07	41.23	56.79
0.565	0.07	0.10	39.35	39.52	56.00
3.814	0.18	0.16	28.73	29.07	56.00
16.228	0.33	0.38	34.31	35.02	60.00
24.349	0.38	0.52	31.34	32.24	60.00

**Average:**

0.171	0.01	0.10	15.10	15.21	54.91
0.299	0.04	0.10	12.30	12.44	50.27
0.455	0.06	0.10	10.30	10.46	46.78
0.566	0.07	0.10	8.90	9.07	46.00
3.814	0.18	0.16	24.90	25.24	46.00
16.228	0.33	0.38	29.30	30.01	50.00
24.349	0.38	0.52	28.40	29.30	50.00

Remarks :

1. “ \* ” means that this data is the worst emission level.



## CONDUCTED EMISSION DATA

Date of Test : Aug.21, 2000 EUT : Wireless Lan Router / Lan Router  
 Test Mode : Mode 1 Detect Mode : Quasi-Peak & Average

Frequency	Cable Loss	LISN Factor	Reading Level	Measurement Level	Limits
MHz	dB	dB	Line2 dBuV	Line2 dBuV	dBuV
0.158	0.00	0.10	47.61	47.71	65.58
0.291	0.03	0.10	43.43	43.56	60.51
*0.435	0.06	0.10	40.97	41.13	57.15
3.724	0.18	0.16	29.06	29.40	56.00
16.166	0.33	0.37	31.62	32.32	60.00
24.005	0.38	0.52	26.20	27.09	60.00
<b>Average:</b>					
0.158	0.00	0.10	17.70	17.80	55.57
0.291	0.03	0.10	12.70	12.83	50.50
0.425	0.06	0.10	10.20	10.36	47.35
3.724	0.18	0.16	22.80	23.14	46.00
16.166	0.33	0.37	26.70	27.40	50.00
24.005	0.38	0.52	24.50	25.39	50.00

**Remarks :**

1. “ \* ” means that this data is the worst emission level.



## RADIATED EMISSION DATA

Date of Test : Aug.21, 2000 EUT : Wireless Lan Router / Lan Router  
 Test Mode : Mode 1 Test Site : No.2 Open Test Site

Freq.	Cable	Probe	PreAMP	Reading	Measurement	Margin	Limit	Ant	Turn
MHz	Loss Factor	dB/m	dB	Level	Horizontal	dB	dBuV	dB	dBuV/m
MHz	dB	dB/m	dB	dBuV	dBuV/m	dB	dBuV/m	cm	deg

75.000	1.58	7.10	0.00	4.55	13.23	16.77	30.00	401	22
80.000	1.64	8.20	0.00	5.49	15.32	14.68	30.00	401	186
125.000	2.07	11.84	0.00	6.98	20.89	9.11	30.00	401	136
150.000	2.31	10.72	0.00	4.38	17.41	12.59	30.00	401	1
175.000	2.55	9.76	0.00	5.64	17.95	12.05	30.00	401	190
179.994	2.60	9.47	0.00	4.68	16.74	13.26	30.00	401	8
200.000	2.78	9.30	0.00	6.72	18.80	11.20	30.00	401	76
250.008	3.27	12.61	0.00	3.86	19.74	17.26	37.00	401	32
*747.997	6.09	20.19	0.00	7.61	33.88	3.12	37.00	142	115

**Remarks:**

- 1.All Readings below 1GHz are Quasi-Peak, above are average value.
- 2.“ \* ”, means this data is the worst emission level.
- 3.Emission Level = Reading Level + Antenna Factor + Cable loss

j

## RADIATED EMISSION DATA

Date of Test : Aug.21, 2000 EUT : Wireless Lan Router / Lan Router  
 Test Mode : Mode 1 Test Site : No.2 Open Test Site

Freq. Cable Probe PreAMP Reading Measurement Margin Limit Ant Turn  
 Loss Factor Level Vertical  
 MHz dB dB/m dB dBuV dBuV/m dB dBuV/m cm deg

Freq. MHz	Cable Loss Factor dB	Probe dB/m	PreAMP dB	Reading dBuV	Measurement dBuV/m	Margin dB	Limit dBuV/m	Ant cm	Turn deg
*40.000	1.24	12.84	0.00	9.99	24.07	5.93	30.00	99	203
50.000	1.35	7.39	0.00	14.90	23.64	6.36	30.00	99	5
60.000	1.44	6.00	0.00	9.99	17.43	12.57	30.00	99	50
64.000	1.48	6.58	0.00	9.04	17.10	12.90	30.00	99	28
75.000	1.58	6.83	0.00	10.61	19.02	10.98	30.00	99	98
125.000	2.07	11.49	0.00	10.23	23.79	6.21	30.00	99	26
150.000	2.31	10.43	0.00	7.36	20.10	9.90	30.00	99	201
160.000	2.40	10.28	0.00	5.19	17.87	12.13	30.00	99	178
175.000	2.55	9.32	0.00	9.85	21.72	8.28	30.00	99	182
200.000	2.78	9.07	0.00	15.89	27.75	2.25	30.00	99	128
220.000	2.98	9.29	0.00	7.80	20.07	9.93	30.00	99	61
250.008	3.27	12.26	0.00	4.54	20.07	16.93	37.00	99	40

**Remarks:**

- 1.All Readings below 1GHz are Quasi-Peak, above are average value.
- 2.“ \* ”, means this data is the worst emission level.
- 3.Emission Level = Reading Level + Antenna Factor + Cable loss

