

Exhibit C - Measurement Report





ELECTROMAGNETIC INTERFERENCE TEST REPORT

Company : ZyXEL COMMUNICATIONS CORPORATION.
Address : NO.6, Innovation Rd. II, Science- Based
Industrial Park, Hsin-Chu, Taiwan , R.O.C
Sample Name : WAN Bridge/Router
Model : Prestige 153X
Date Received : MAR. 16, 1998
Date Tested : MAR. 26, 1998

MEASUREMENT PORCEDURE USED :
CISPR 22, CLASS B, 1996

WE HEREBY CERTIFY THAT: The measurements shown in the attachment were made in accordance with the procedures indicated, and the energy emitted by the equipment was found to be within the limits applicable. We assume full responsibility for the accuracy and completeness of these measurements and vouch for the qualifications of all persons taking them.

	Name	Signature	Date
Testing Engineer	C.F.Wu/NVLAP	<i>C.F. Wu</i>	<i>APR. 17, 1998</i>
Approving Manager	Paul Y. Liou/NVLAP	<i>Paul Y. Liou</i>	<i>Apr. 20, 1998</i>

Notes :

1. This report will be invalid if duplicated or photocopied in part.
2. This report refers only to the specimen(s) submitted to testing, and be invalid as seperately used.
3. This report is invalid with out examination stamp and signature of this institute.
4. The tested specimen(s) will be preserved for thirty days from the date issued.
5. This is a NIST/NVLAP accredited report but not constituted and eudorsed by U.S. government.



TABLE OF CONTENTS

<u>TITLE</u>	<u>PAGE NO.</u>
TEST REPORT CERTIFICATION	
1. GENERAL INFORMATION	3
1.1 DESCRIPTION OF EUT.....	3
1.2 DESCRIPTION OF PERIPHERALS.....	4
1.3 EUT & PERIPHERALS SETUP DIAGRAM.....	6
1.4 EUT OPERATING CONDITION.....	7
1.5 DESCRIPTION OF TEST SITE.....	7
2. CONDUCTED POWERLINE TEST	8
2.1 TEST EQUIPMENTS.....	8
2.2 TEST SETUP.....	8
2.3 CONDUCTED POWER LINE EMISSION LIMIT.....	9
2.4 TEST PROCEDURE.....	9
2.5 UNCERTAINTY OF CONDUCTED EMISSION.....	9
2.6 LINE CONDUCTED RF VOLTAGE MEASUREMENT.....	10
2.7 PHOTOS OF CONDUCTION TEST.....	11
3. RADIATED EMISSION TEST	12
3.1 TEST EQUIPMENTS.....	12
3.2 TEST SETUP.....	12
3.3 RADIATION LIMIT.....	13
3.4 TEST PROCEDURE.....	13
3.5 UNCERTAINTY OF RADIATED EMISSION.....	13
3.6 RADIATED RF NOISE MEASUREMENT.....	14
3.7 PHOTOS OF OPEN SITE.....	15-16



1. GENERAL INFORMATION

1.1 DESCRIPTION OF EUT

MANUFACTURER : ZYXEL COMMUNICATIONS CORPORATION.

SAMPLE NAME : WAN Bridge/Router

MODEL NUMBER : Prestige 153X

SERIAL NO. : -----

POWER SUPPLY : 16VAC(from power adapter)



1.2 DESCRIPTION OF PERIPHERALS

(1) PC

MODEL NUMBER : POWERMATE 486SX/25e
SERIAL NUMBER : -----
MANUFACTURER : NEC CORP.
F.C.C. ID : B7ZA72
POWER CORD : Unshielded , Detachable , 1.8m

(2) MONITOR

MODEL NUMBER : JC-1404HMA
SERIAL NUMBER : 08D00346
MANUFACTURER : NEC CORP.
F.C.C. ID : A3D5YRJC-1404HMA
POWER CORD : Unshielded , Detachable , 1.8m

(3) KEYBOARD

PRODUCT NUMBER : M
SERIAL NUMBER : 82G2383
MANUFACTURER : IBM CORP.
F.C.C. ID : IYL60G3571
POWER CABLE : +5VDC (From PC)

(4) PRINTER

MODEL NUMBER : 5152-002
SERIAL NUMBER : 0754365
MANUFACTURER : IBM CORP.
F.C.C. ID : BKM9A85152002

(5) WAN Bridge/Router

MODEL NUMBER : Prestige 153X
SERIAL NUMBER : -----
MANUFACTURER : -----
FCC ID : -----
POWER SOURCE : 16VAC(from power adapter)



(6) Cable

NO.	TYPE	Connector	Shielded	Length
A	D Type	RS232, metal	No	1.5m
B	WAN cable	RJ-45, plastic	Yes	10m
C	WAN cable	RJ-45, plastic	No	50ft
D	LAN cable	RJ-45, plastic	No	10m



1.3 EUT & PERIPHERALS SETUP DIAGRAM

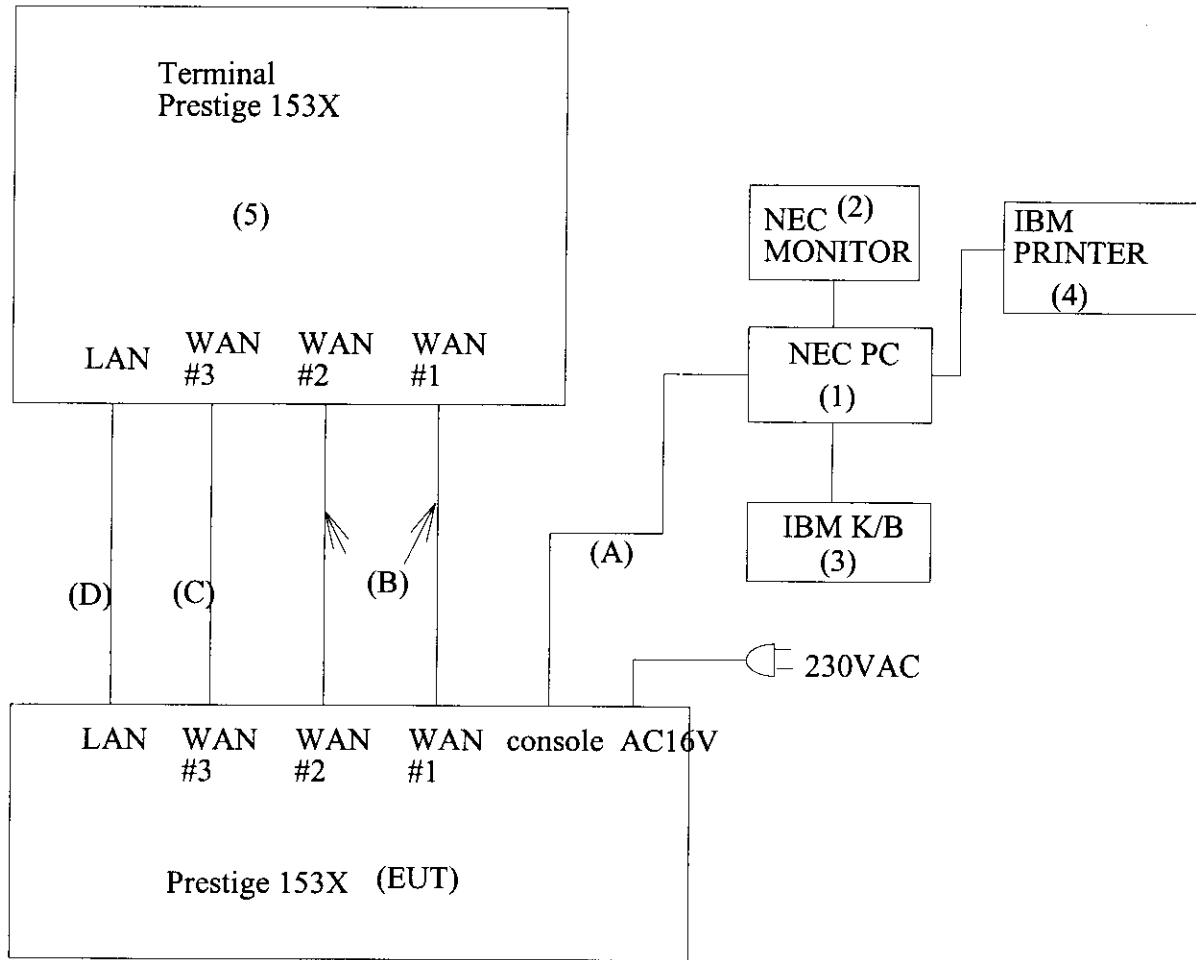

The indicated numbers (1)(2)(A)(B)---please refer to item 1.2.



1.4 EUT OPERATING CONDITION

1. Turn on EUT's power.
2. EUT will send/receive pockets to/from Terminal via WAN#1 cable.
3. EUT will send/receive pockets to/from Terminal via WAN#2 cable.
4. EUT will send/receive pockets to/from Terminal via WAN#3 cable.
5. EUT will send/receive pockets to/from Terminal via LAN cable.
6. EUT will show statistics message to PC via RS-232 cable.
7. Repeat step 1~6.

1.5 DESCRIPTION OF TEST SITE

SITE DESCRIPTION : FCC certificate NO. :31040/SIT
DNV certificate NO. :510-96-1016
TUV certificate NO. : I9664582-9610
Lloyd's certificate NO. :LA003
BCIQ certificate NO. :SL2-IN-E-02
NVLAP Lab code : 200118-0
CNLA certificate NO. : CNLA-ZL97018
VCCI certificate NO. : R-629, C-650

NAME OF SITE : Electronics Research & Service Organization
Industrial Technology Research Institute

SITE LOCATION : K500, 195-4 , sec. 4, Chung Hsing Rd.,
Chu-Tung Chen. Hsin-Chu, Taiwan 31015 R.O.C.



2. CONDUCTED POWERLINE TEST

2.1 TEST EQUIPMENTS

The following test equipments are used during the conducted powerline tests :

MANUFACTURER OR TYPE	MODEL No	SERIAL NO.	DATE OF CALIBRATION
SPECTRUM ANALYZER & DISPLAY	HP 8568A	2235A02320	MAR. 05, 1998
QUASI-PEAK ADAPTER	HP 85650 A	2341A00672	MAR. 05, 1998
ISOLATION TRANSFORMER	SOLAR 7032-1	N/A	N/A
L.I.S.N.	EMCO 3850/2	9311-1025 9401-1028	MAR. 24, 1998
TEST RECEIVER	R/S ESH3	8720791118	MAR. 13, 1998
SHIELDED ROOM	KEENE 5983	N/A	N/A

2.2 TEST SETUP

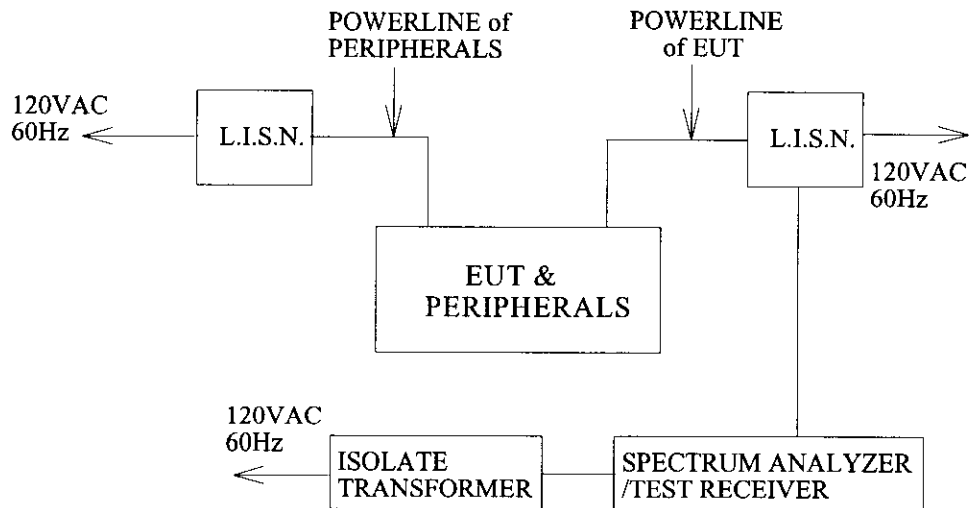



2.3 CONDUCTED POWER LINE EMISSION LIMIT

FREQUENCY (MHz)	MAXIMUM RF LINE VOLTAGE (dB μ V)			
	CLASS A		CLASS B	
	Q.P.	Ave.	Q.P.	Ave.
0.15-0.50	79	66	66-56	56-46
0.50-5.00	73	60	56	46
5.00-30.0	73	60	60	50

2.4 TEST PROCEDURE

The test procedure is performed in a 12ft \times 12ft \times 8ft(L \times W \times H) shielded room. the EUT along with its peripherals were placed on a 1.0m(W) \times 1.5m(L) and 0.8m in height wooden table and the EUT was adjusted to maintain a 0.4 meter space from a vertical reference plane. The EUT was connected to power mains through a line impedance stabilization network (LISN) which provides 50 ohm coupling impedance for measuring instrument and the chasis ground was bounded to the horizontal ground plane of shielded room. All peripherals were connected to the second LISN and the chasis ground also bounded to the horizontal ground plane of shielded room. The excess power cable between the EUT and the LISN was bundled. The power cables of peripherals were unbundled. All connecting cables of EUT and peripherals were moved to find the maximum emission.

2.5 UNCERTAINTY OF CONDUCTED EMISSION

The uncertainty of conducted emission is ± 1.36 dB.



2.6 LINE CONDUCTED RF VOLTAGE MEASUREMENT

The frequency spectrum from 0.45 MHz to 30 MHz was investigated. All emissions not reported below are more than 20 dB below the prescribed limits.

All readings are Quasi-peak values.

Temperature : 26 °C

Humidity : 55 % R.H.

FREQUENCY (MHz)	READING(dB μ V)				LIMITS (dB μ V)	
	ONE END & GRD'D		THE OTHER END & GRD'D		Q.P.	Ave.
	Q.P.	Ave.	Q.P.	Ave.		
0.150	*	*	*	*	66.00	56.00
0.237	31.06	*	*	*	62.22	52.22
6.914	35.73	*	*	*	60.00	50.00
7.368	39.03	*	*	*	60.00	50.00
7.893	*	*	40.73	*	60.00	50.00
8.020	*	*	43.04	*	60.00	50.00
8.916	36.74	*	*	*	60.00	50.00
9.552	*	*	32.24	*	60.00	50.00
10.179	33.85	*	*	*	60.00	50.00
10.233	*	*	32.45	*	60.00	50.00
11.198	35.15	*	*	*	60.00	50.00
11.621	*	*	37.45	*	60.00	50.00
12.649	32.16	*	32.86	*	60.00	50.00
13.197	32.96	*	35.16	*	60.00	50.00
15.470	36.17	*	36.87	*	60.00	50.00
21.486	32.88	*	32.18	*	60.00	50.00
23.762	32.59	*	34.59	*	60.00	50.00
30.000	*	*	*	*	60.00	50.00

REMARKS : * Undetectable

3. RADIATED EMISSION TEST

3.1 TEST EQUIPMENTS

The following test equipments are utilized in making the measurements contained in this report.

MANUFACTURER OR TYPE	MODEL NO	SERIAL NO.	DATE OF CALIBRATION
CHASE BI-LOG ANTENNA	CBL611A	1546	MAY 26, 1997
R/S TEST RECEIVER	ESMI	842088/005	MAY 22, 1997
ANECHOIC/SHIELDED ROOM	KEENE 5981	N/A	N/A

3.2 TEST SETUP

The diagram below shows the test setup which is utilized to make these measurements.

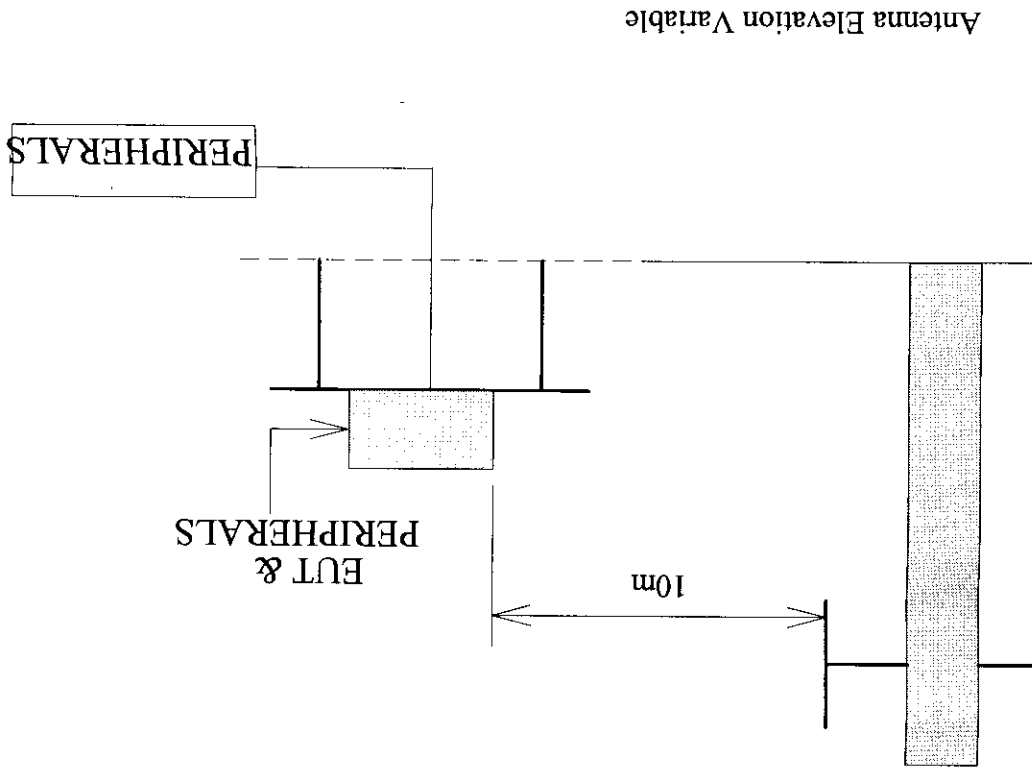

Antenna Elevation Variable



Industrial Technology Research Institute
 Electronics Research & Service Organization
 Bldg. 17, 195-4 Sec. 4, Chung Hsing Rd., Chung Hsing, Hsinchu, 310
 Taiwan, Republic Of China
 TEL : 886-3-5917069 FAX : 886-3-5825720



3.3 RADIATION LIMIT

All emanation from a class B computing device or system, including any network of conductors and apparatus connected thereto, shall not exceed the level of field strengths specified below :

FREQUENCY (MHz)	DISTANCE (METERS)	FIELD STRENGTHS(dB V/M)	
		CLASS A	CLASS B
30 230	10	40	30
230 1000	10	47	37

- Note : (1)The tighter limit shall apply at the edge between two frequency bands.
(2)Distance refers to the distance in meters between the measuring instrument antenna and the closest point of any part of the device or system.

3.4 TEST PROCEDURE

The devices under test were placed on a rotatable table top 0.8 meter above ground. The table was rotated 360 degrees to determine the position of the highest radiation. EUT is set 10 meters from the interference receiving antenna which is mounted on the top of a variable height mast. The antenna height is varied between one meter and four meters above ground to find the maximum value of the field strength Both horizontal polarization and vertical polarization of the antenna are set to make the measurement.

The bandwidth setting on the E.M.I. meter (R/S TEST RECEIVER ESMI) is 120 KHz.

The levels are quasi peak value readings. The frequency spectrum from 30MHz to 1000MHz was investigated.

3.5 UNCERTAINTY OF RADIATED EMISSION

The uncertainty of radiated emission is ± 2.72 dB.



3.6 RADIATED RF NOISE MEASUREMENT

The frequency spectrum from 30 MHz to 1000 MHz was investigated. All emissions not reported below are more than 20 dB below the prescribed limits.

All readings are quasi-peak values.

Temperature : 27 °C

Humidity : 71% RH

FREQ- UENCY (MHz)	ANTENNA FACTOR (dB)	CABLE LOSS (dB)	METER READING AT10m (dB μ V/M)		LIMITS (dB μ V/M)	EMISSION LEVEL AT10m (dB μ V/M)	
			HORIZON- TAL	VERTICAL		HORIZON- TAL	VERTICAL
30.00	19.71	1.20	*	*	30.00	*	*
61.44	5.81	1.61	10.92	17.64	30.00	18.34	25.06
122.89	11.92	2.26	5.60	8.68	30.00	19.78	22.86
184.33	9.13	2.72	12.32	7.84	30.00	24.17	19.69
200.00	8.95	2.80	11.20	15.12	30.00	22.95	26.87
245.77	12.14	3.07	12.60	12.88	37.00	27.81	28.09
307.22	13.46	3.34	10.92	11.48	37.00	27.72	28.28
350.00	14.54	3.55	7.56	*	37.00	25.65	*
353.30	14.62	3.57	9.24	*	37.00	27.43	*
368.66	15.00	3.64	9.52	10.92	37.00	28.16	29.56
430.10	16.41	3.92	8.96	9.24	37.00	29.29	29.57
552.99	18.87	4.36	5.32	5.04	37.00	28.55	28.27
614.43	19.94	4.56	*	5.88	37.00	*	30.38
1000.00	24.69	5.70	*	*	37.00	*	*

REMARKS :

1. * Undetectable
2. Emission level (dB μ V/M) = Antenna Factor (dB) + Cable loss (dB)
 + Meter Reading (dB μ V/M).

Description of Equipment

Applicant's Name : ZyXEL COMMUNICATIONS CORPORATION

Applicant's Address : No. 6, Innovation Rd. II, Science- Based
Industrial Park, Hsin-Chu, Taiwan, R.O.C.

Description of EUT : WAN Bridge / Router

(a) Model No. : Prestige 153X

(b) FCC ID. : I 8 8 PRESTIGE153X

(c) Power Supply : 16V AC (From Power Adapter)