



WHA YU INDUSTRIAL CO., LTD.(HEAD OFFICE)
 DONGGUAN AEON TECH CO.,LTD.(CHINA)
 SUZHOU AEON TECH CO.,LTD.(CHINA)
 AEON TECH (SHANGHAI) CO.,LTD(CHINA)
 DONGGUAN PARNER TECH CO.,LTD.(CHINA)



SPECIFICATION FOR APPROVAL

CUSTOMER: 合勤科技股份有限公司

PART NAME: PCB Antenna Assembly

PART NO: 65-031-660101B

REVISION:

W. Y. P/NO: C034-510777-A

REV: XI

	MANUFACTURER SIGNATURE	CUSTOMER SIGNATURE
APPROVED BY :		
DATE :		

WHA YU GROUP

WHA YU INDUSTRIAL CO., LTD.(HEAD OFFICE)

譚裕實業股份有限公司

Address: No. 326,Sec. 2,Kung Tao 5 Road, Hsin Chu City, Taiwan, R.O.C.

Tel:+886-3-5714225(REP.) Fax:+ 886-3-5713853 . + 886-3-5723600

DONGGUAN AEON TECH CO.,LTD.(CHINA)

東莞台霖電子通訊有限公司

Address:Hupan Industrial District,Tai Ling Shan Town,Dong Guan City,Guangdong,China

Tel:+86-769-85655858 Fax:+86-769-85655258

SUZHOU AEON TECH CO.,LTD(CHINA)

蘇州華廣電通有限公司

Address:Limin North Road, LiLi Town,LiLi Industrial Park,LinHu Economic Zone

Wujiang City,Jiangsu Province,China

Tel:+86-512-63627980 Fax:+86-512-63627981

AEON TECH (SHANGHAI) CO.,LTD(CHINA)

普翔電子貿易(上海)有限公司

Address:Flat 501,5F,Build 27, NO.68,Guiqing Road, Huhui District, Shanghai,China

Tel:+86-21-64959151 Fax:+86-21-64959059

DONGGUAN PARNER TECH CO.,LTD.(CHINA)

東莞倍能電子有限公司

Address:Hupan Industrial District, Shida Road, Tai Ling Shan Town,

Dong Guan City, Guangdong, China

Tel:+86-769-81662366 Fax:+86-769-81602681

Contents

<i>Item</i>	<i>Description</i>	<i>Page</i>
1.	天線規格表 1
2.	成品圖 2
3.	測試報告 3

PCB Antenna Assembly

Specification

1. Electrical Properties:

- 1.1 Frequency Range.....2.4GHz ~ 2.5GHz
- 1.2 Impedance50 Nominal
- 1.3 VSWR 5.85:1 Max.
- 1.4 Return Loss..... -3dB Max.
- 1.5 Radiation Omni-directional
- 1.6 Gain(peak)..... 3.5dBi (With Housing)
- 1.7 Cable Loss..... 0.8dB Max.
- 1.8 Polarization..... Linear ; Vertical
- 1.9 Admitted Power..... 1W
- 1.10 Cable..... 1.13 Coaxial Cable

2. Physical Properties :

- 2.1 Operating Temp. -20 ~ +65
- 2.2 Storage Temp. -30 ~ +75

REV	DATE	DESCRIPTION
X1	5/20-2010	New Issue

Note : Label品名規格
 1.中包裝:依客訂單中品名規格敘述
 2.外箱:只敘述產品大類即可

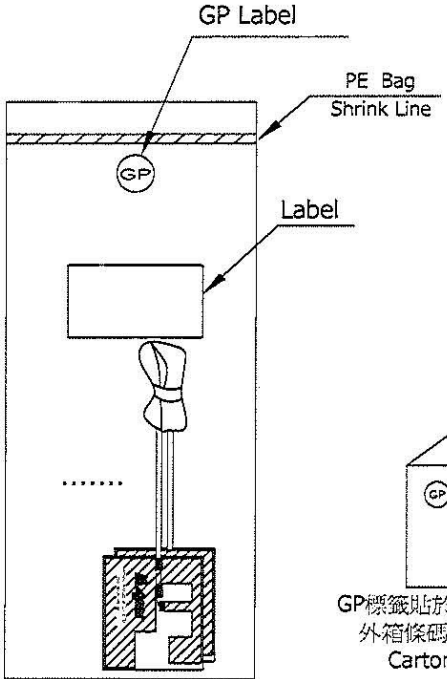
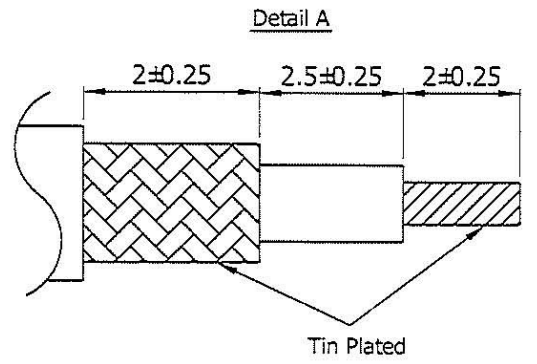
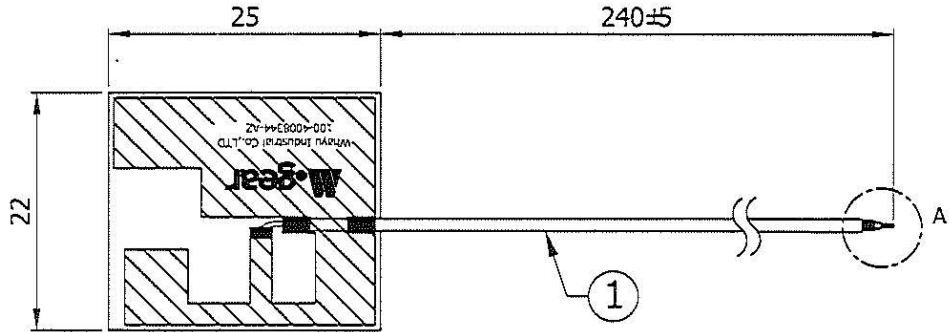

GP標籤貼於客戶料號左上角共2PCS
 外箱條碼標籤貼於右上角1PCS
 Carton:320*320*200mm

(10 pcs/bundle)
 Packing :10 pcs/bag(W)105 x (L)330mm

4	泡棉雙面背膠	(W)13*(L)22;T=3.0mm ; EVA+G4000 雙面背膠	1	
3	泡棉雙面背膠	(W)7*(L)22;T=3.0mm ; EVA+G4000 雙面背膠	1	
2	PCB	FR4 ; 24mil ; 1/2 Oz	1	
1	Cable	φ1.13mm Cable,Gray	1	
NO	DESCRIPTION		QTY	REMARK

CUSTOMER'S SIGNATURE

XX. ±5.0 APPROVED
 X. ±3.0
 .X ±1.0 CHECKED
 .XX ±0.5
 .XXX ±0.1 DRAWING
 5-20-10

CUSTOMER: 合勤
 PART NO : 65-031-660101B
 PART NAME: RF PCB Antenna Assembly
 W.Y P/NO : C034-510777-A
 REV UNIT FILE : 1005-0030
 X1 mm SHEET : 1/1

M.gear Wha Yu Group
 THIS DRAWING, AND IT'S INHERANT DESIGN CONCEPTS, ARE THE PROPERTY OF WHA YU AND AS SUCH MAY NOT BE COPIED, REPRODUCED, OR GIVEN TO THIRD PARTIES WITHOUT THE WRITTEN CONSENT OF WHA YU.

PCB Antenna SPEC :2.4~2.5GHz

P/NO : C034-510777-A

NO: 1005-0030

