

EMC TEST REPORT

Report No. : EME-070046

Model No. : NWD-670S

Issued Date : Feb. 05, 2007

Applicant : ZyXEL Communications Corporation
6, Innovation Rd II, Science-Based Industrial Park,
Hsin-Chu, Taiwan

Test By : Intertek Testing Services Taiwan Ltd.
No. 11, Lane 275, Ko-Nan 1 Street, Chia-Tung Li,
Shiang-Shan District, Hsinchu City, Taiwan

This test report consists of 70 pages in total. It may be duplicated completely for legal use with the allowance of the applicant. It shall not be reproduced except in full, without the written approval of Intertek Laboratory. The test result(s) in this report only applies to the tested sample(s).

Project Engineer



Kevin Chen

Reviewed By

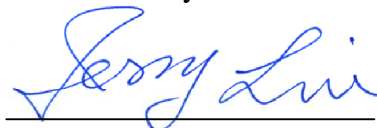

Jerry Liu

Table of Contents

Summary of Tests4

1. General information5

 1.1 Identification of the EUT.....5

 1.2 Additional information about the EUT5

 1.3 Antenna description6

 1.4 Peripherals equipment6

2. Test specifications7

 2.1 Test standard7

 2.2 Operation mode7

 2.3 Test equipment.....8

3. Minimum 6dB Bandwidth test9

 3.1 Operating environment.....9

 3.2 Test setup & procedure9

 3.3 Measured data of Minimum 6dB Bandwidth test results9

4. Maximum Output Power test17

 4.1 Operating environment.....17

 4.2 Test setup & procedure17

 4.3 Measured data of Maximum Output Power test results17

5. RF Antenna Conducted Spurious test.....18

 5.1 Operating environment.....18

 5.2 Test setup & procedure18

 5.3 Measured data of the highest RF Antenna Conducted Spurious test result.....18

6. Radiated Emission test40

 6.1 Operating environment.....40

 6.2 Test setup & procedure40

 6.3 Emission limits41

 6.4 Radiated spurious emission test data.....42

 6.4.1 Measurement results: frequencies equal to or less than 1 GHz.....42

 6.4.2 Measurement results: frequency above 1GHz.....43

7. Power Spectrum Density test50

 7.1 Operating environment.....50

 7.2 Test setup & procedure50

 7.3 Measured data of Power Spectrum Density test results50

8. Emission on the band edge.....58

 8.1 Operating environment.....58

 8.2 Test setup & procedure58

 8.3 Test Result59

 8.4 Radiated Method59

9. Power Line Conducted Emission test §FCC 15.20767

 9.1 Operating environment.....67

 9.2 Test setup & procedure67

 9.3 Emission limit.....68

9.4 Uncertainty of Conducted Emission.....68
9.5 Power Line Conducted Emission test data69

Summary of Tests**802.11g Wireless Super G MiniPCI Card -Model: NWD-670S
FCC ID: I88NWD670S**

Test	Reference	Results
Minimum 6dB Bandwidth test	15.247(a)(2)	Pass
Maximum Output Power test	15.247(b)	Pass
RF Antenna Conducted Spurious test	15.247(d)	Pass
Radiated Spurious Emission test	15.205, 15.209	Pass
Power Spectrum Density test	15.247(e)	Pass
Emission on the Band Edge test	15.247(d)	Pass
AC Power Line Conducted Emission test	15.207	Pass

1. General information

1.1 Identification of the EUT

Applicant	: ZyXEL Communications Corporation
Product	: 802.11g Wireless Super G MiniPCI Card
Model No.	: NWD-670S
FCC ID.	: I88NWD670S
Frequency Range	: 2412MHz ~ 2462MHz
Channel Number	: 11 channels
Frequency of Each Channel	: 2412MHz, 2417MHz, 2422MHz, 2427MHz, 2432MHz, 2437MHz, 2442MHz, 2447MHz, 2452MHz, 2457MHz, 2462MHz
Type of Modulation	: DSSS, OFDM
Rated Power	: 3.3Vdc from Notebook PC
Power Cord	: RJ-45 UTP Cat.5 10meter × 1
Sample Received	: Feb. 19, 2007
Test Date(s)	: Jan. 29, 2007 ~ Feb. 05, 2007

A FCC DoC report has been generated for the client.

1.2 Additional information about the EUT

The EUT is a 802.11g Wireless Super G MiniPCI Card, and was defined as information technology equipment.

For more detail features, please refer to User's manual as file name "Installation guide.pdf"

1.3 Antenna description

The antenna is affixed to the EUT using a unique connector, which allows for replacement of a broken antenna, but DOES NOT use a standard antenna jack or electrical connector.

Antenna Gain : 2.05dBi max

Antenna Type : Dipole Antenna

Connector Type : SMA Plug Reverse

1.4 Peripherals equipment

Peripherals	Manufacturer	Product No.	Serial No.
Notebook PC	DELL	Latitude D610	FXWZK1S

2. Test specifications

2.1 Test standard

The EUT was performed according to the procedures in FCC Part 15 Subpart C Section § 15.205, §15.207, §15.209, §15.247 and ANSI C63.4/2003.

The test of radiated measurements according to FCC Part15 Section 15.33(a) had been conducted and the field strength of this frequency band were all meet limit requirement, thus we evaluate the EUT pass the specified test.

2.2 Operation mode

The EUT was supplied with 3.3Vdc from Notebook PC and it was running in normal operating mode.

Plug the EUT into Notebook via a PCMCIA to CF Card Simulator. Power on the notebook then run the test program “ART”.

With individual verifying, the maximum output power was found at 1Mbps data rate for 802.11b mode and 6Mbps data rate for 802.11g mode. The final tests were executed under these conditions and recorded in this report individually.

2.3 Test equipment

Equipment	Brand	Frequency range	Model No.	Intertek ID No.	Next Cal. Date
EMI Test Receiver	Rohde & Schwarz	9kHz~2.75GHz	ESCS 30	EC303	04/16/2007
EMI Test Receiver	Rohde & Schwarz	20Hz~26.5GHz	ESMI	EC317	08/06/2007
Spectrum Analyzer	Rohde & Schwarz	9kHz~30GHz	FSP 30	EC353	07/23/2007
Spectrum Analyzer	Rohde & Schwarz	20Hz~40GHz	FSEK 30	EC365	10/31/2007
Horn Antenna	SCHWARZBECK	1GHz~18GHz	BBHA 9120 D	EC371	12/22/2007
Horn Antenna	SCHWARZBECK	14GHz~40GHz	BBHA 9170	EC351	07/08/2007
Bilog Antenna	SCHWARZBECK	25MHz~2GHz	VULB 9168	EC347	12/23/2007
Pre-Amplifier	MITEQ	100MHz~26.5GHz	919981	EC373	02/11/2007
Wideband Peak Power Meter/ Sensor	Anritsu	100MHz~18GHz	ML2497A/ MA2491A	EC396	11/09/2007
Controller	HDGmbH	N/A	CM 100	EP346	N/A
Antenna Tower	HDGmbH	N/A	MA 240	EP347	N/A
LISN	Rohde & Schwarz	9KHz~30MHz	ESH3-Z5	EC344	01/13/2007

Note: 1. The above equipments are within the valid calibration period.

2. The test antennas (receiving antenna) are calibration per 3 years.

3. Minimum 6dB Bandwidth test

3.1 Operating environment

Temperature: 23
 Relative Humidity: 55 %
 Atmospheric Pressure: 1023 hPa

3.2 Test setup & procedure

The minimum 6dB bandwidth per FCC §15.247(a)(2) was measured using a 50 ohm spectrum analyzer with the resolutions bandwidth set at 100kHz, the video bandwidth set at 300kHz, and the SPAN>>RBW. The test was performed at 3 channels (lowest, middle and highest channel). The minimum 6-dB modulation bandwidth is in the following Table.

3.3 Measured data of Minimum 6dB Bandwidth test results

Test Model: 802.11b

Channel	Frequency (MHz)	Bandwidth (MHz)	Limit
1 (lowest)	2412	12.24	> 500kHz
6 (middle)	2437	13.52	> 500kHz
11 (highest)	2462	13.52	> 500kHz

Test Model: 802.11g normal mode

Channel	Frequency (MHz)	Bandwidth (MHz)	Limit
1 (lowest)	2412	16.64	> 500kHz
6 (middle)	2437	16.64	> 500kHz
11 (highest)	2462	16.64	> 500kHz

Test Model: 802.11g turbo mode

Channel	Frequency (MHz)	Bandwidth (MHz)	Limit
6 (middle)	2437	32.32	> 500kHz

Please see the plot below.

Test Mode: 802.11b

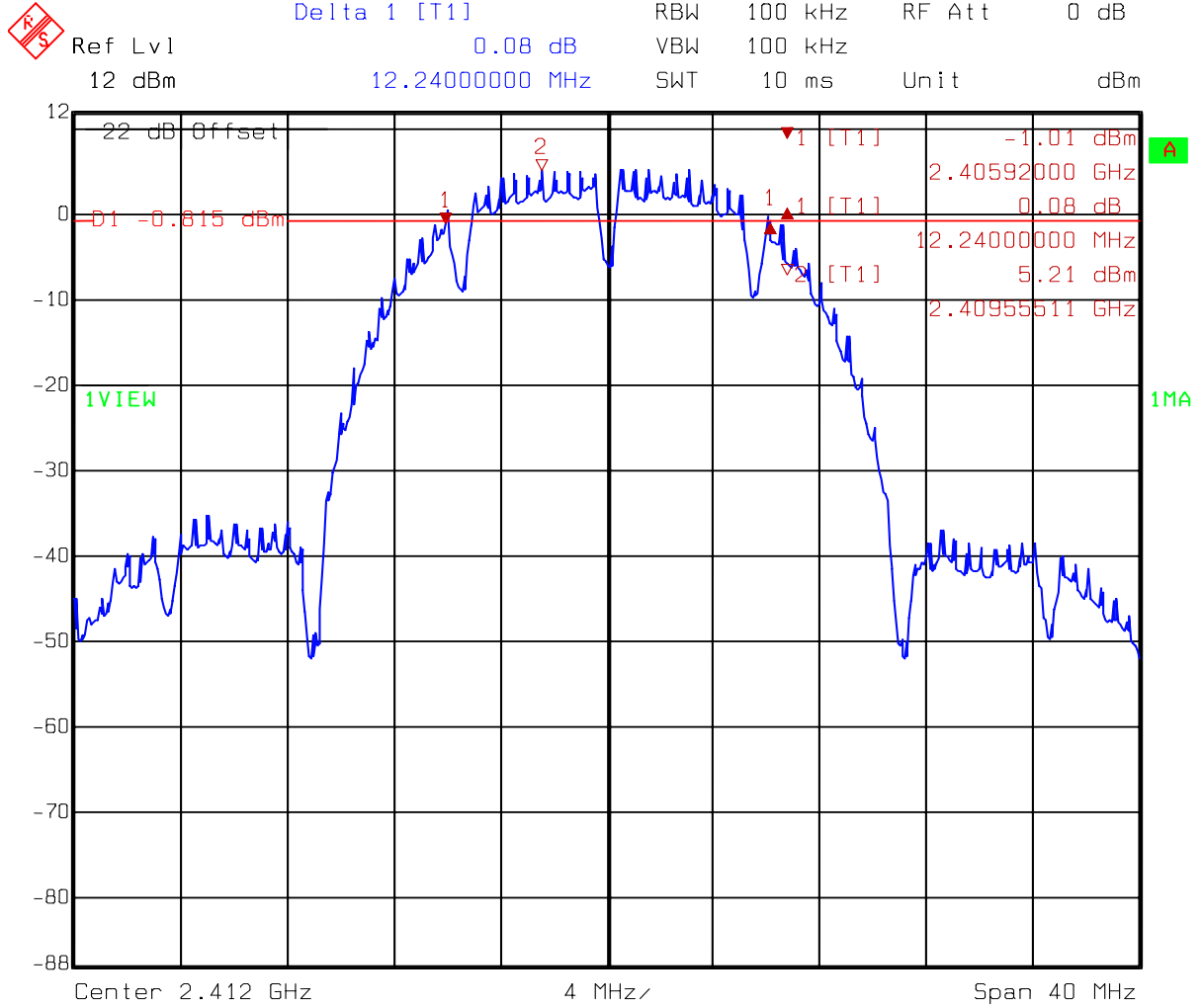

Title: 6dB Band-Width
 Comment A: CH 1 at 802.11b mode
 Date: 05.FEB.2007 09:44:01

Test Mode: 802.11b

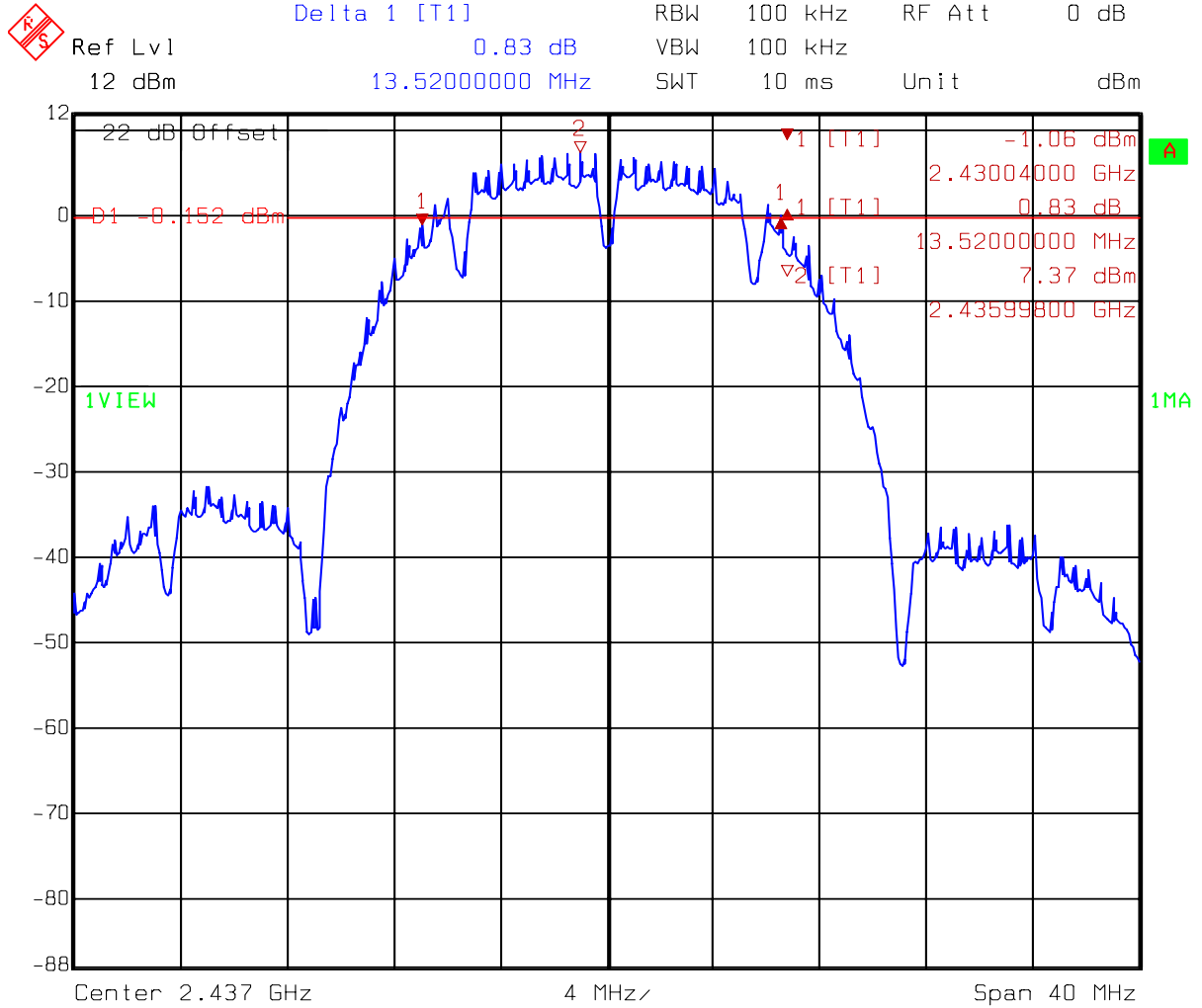

Title: 6dB Band-Width
 Comment A: CH 6 at 802.11b mode
 Date: 25.JAN.2007 17:35:20

Test Mode: 802.11b

	Delta 1 [T1]	RBW	100 kHz	RF Att	0 dB
	Ref Lvl		0.40 dB	VBW	100 kHz
	12 dBm		13.5200000 MHz	SWT	10 ms
				Unit	dBm

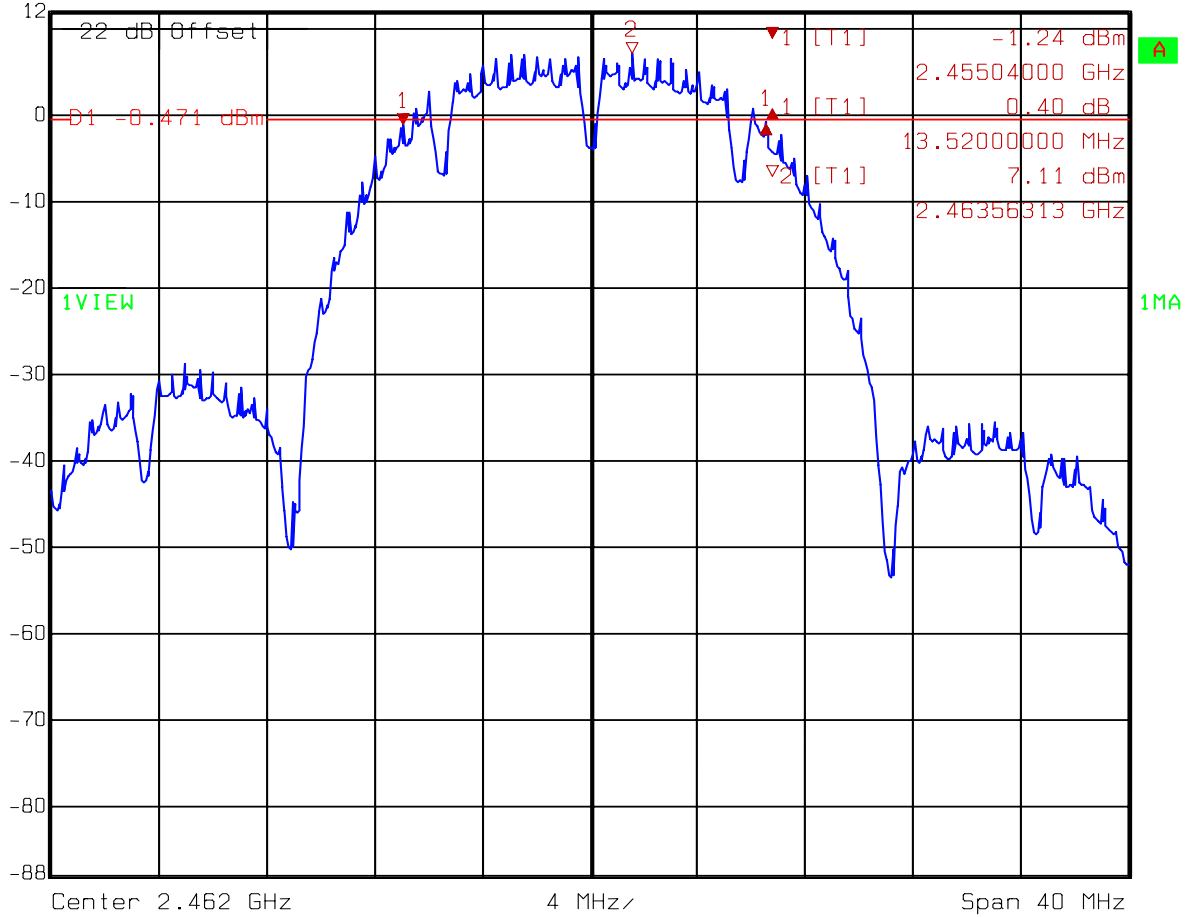

Title: 6dB Band-Width
 Comment A: CH 11 at 802.11b mode
 Date: 25.JAN.2007 17:42:01

Test Mode: 802.11g normal mode

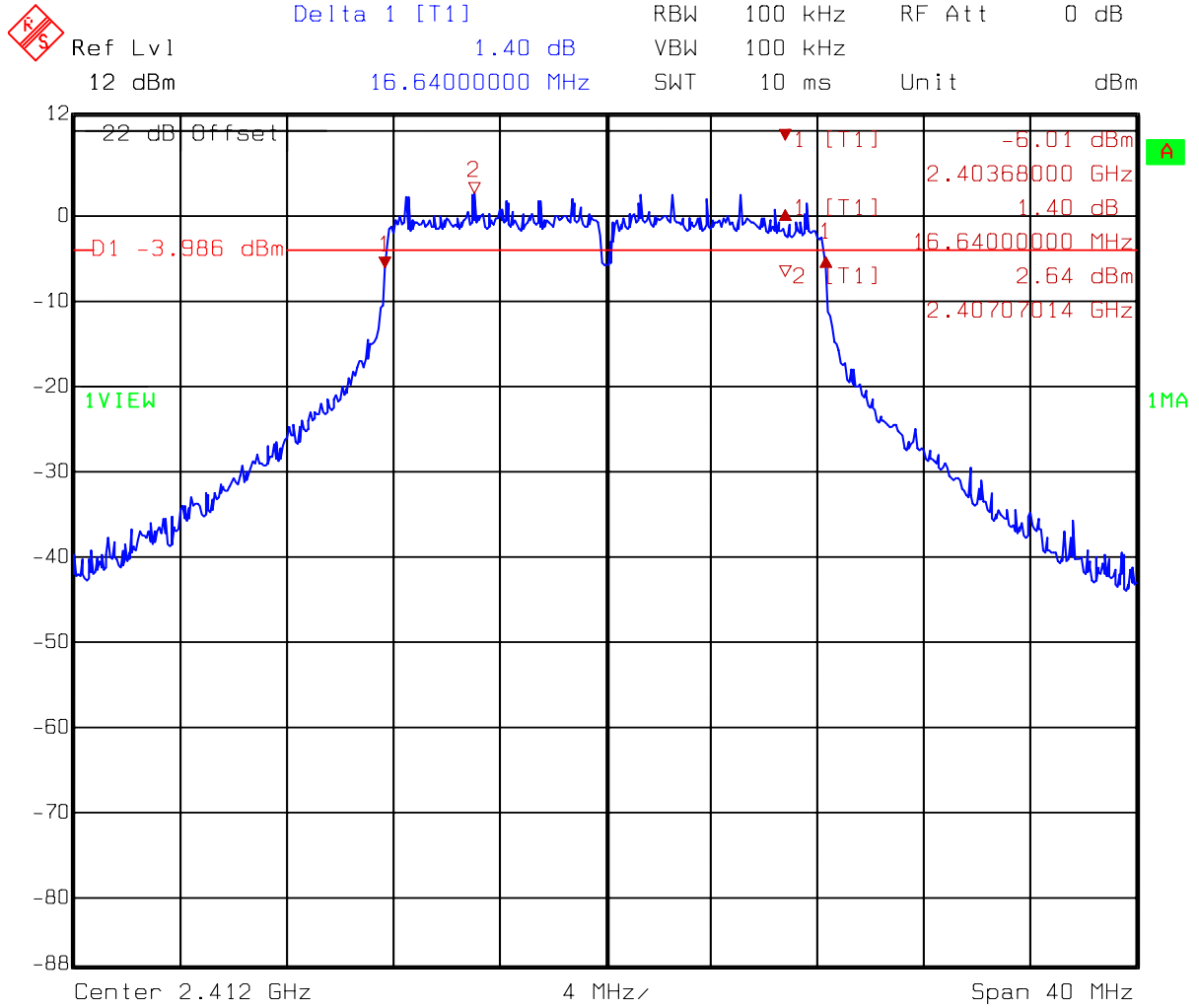

Title: 6dB Band-Width
Comment A: CH 1 at 802.11g mode
Date: 05.FEB.2007 09:49:23

Test Mode: 802.11g normal mode

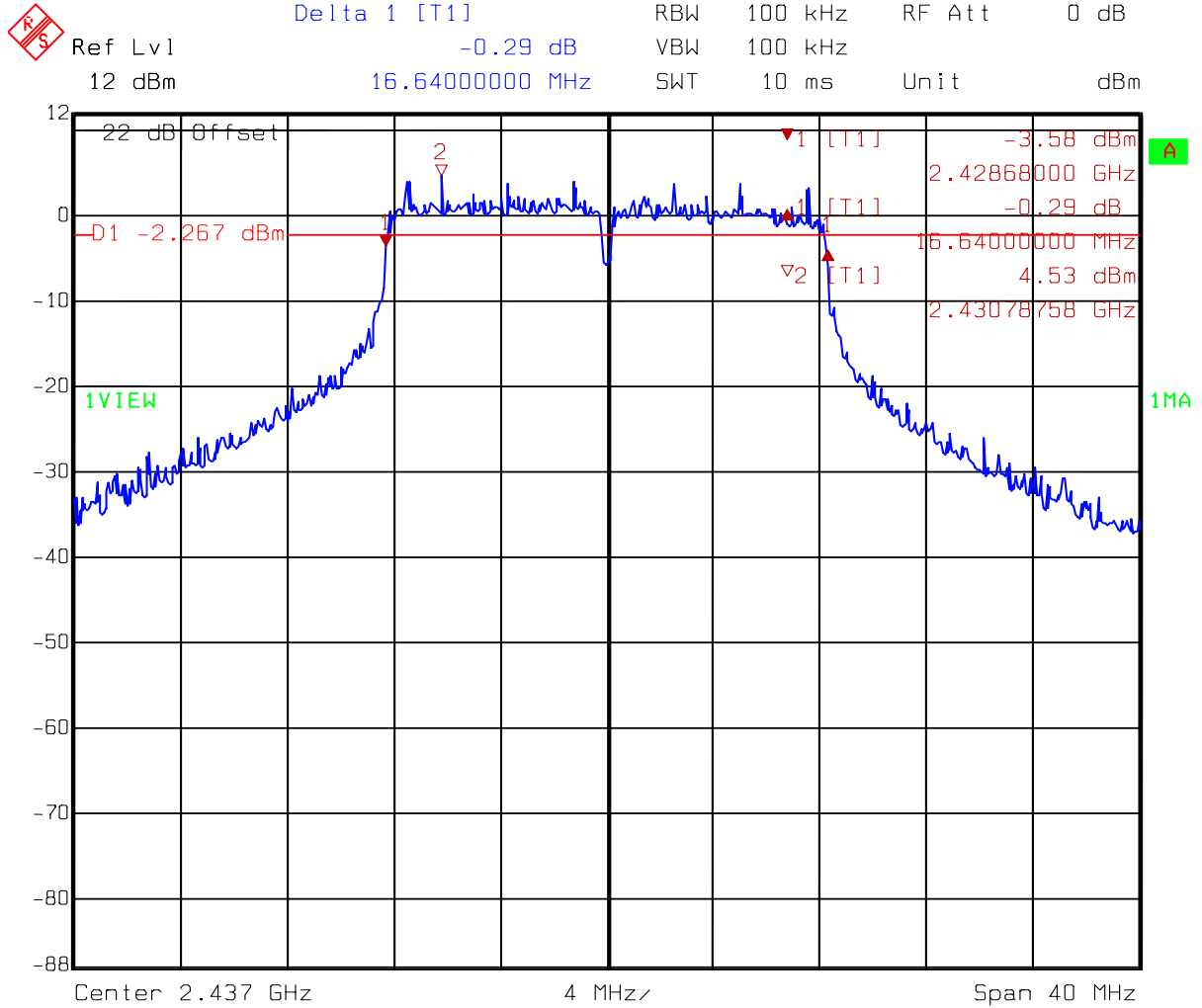

Title: 6dB Band-Width
 Comment A: CH 6 at 802.11g mode
 Date: 25.JAN.2007 17:51:26

Test Mode: 802.11g normal mode

		Delta 1 [T1]	RBW	100 kHz	RF Att	0 dB
	Ref Lvl	-0.06 dB	VBW	100 kHz		
	12 dBm	16.64000000 MHz	SWT	10 ms	Unit	dBm

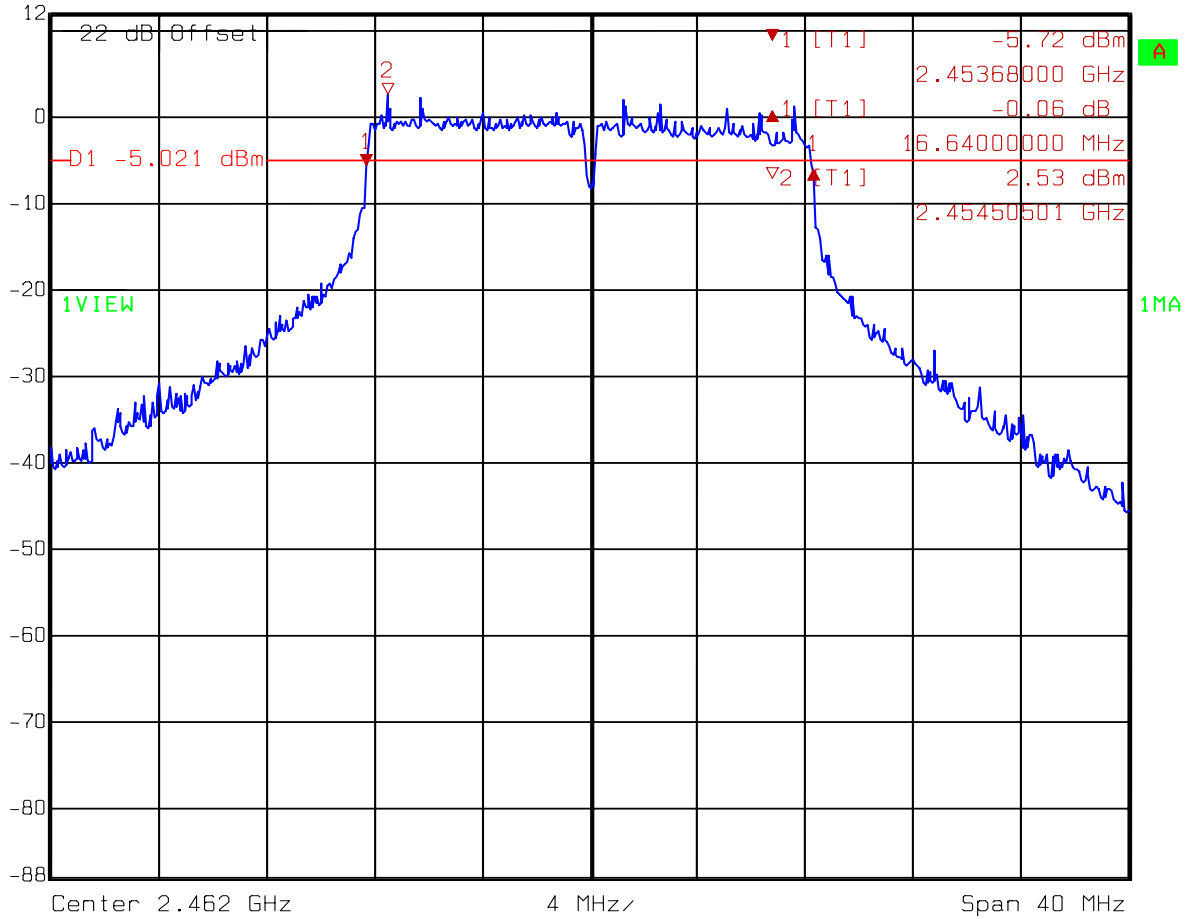

Title: 6dB Band-Width
 Comment A: CH 11 at 802.11g mode
 Date: 05.FEB.2007 12:08:42

Test Mode: 802.11g turbo mode

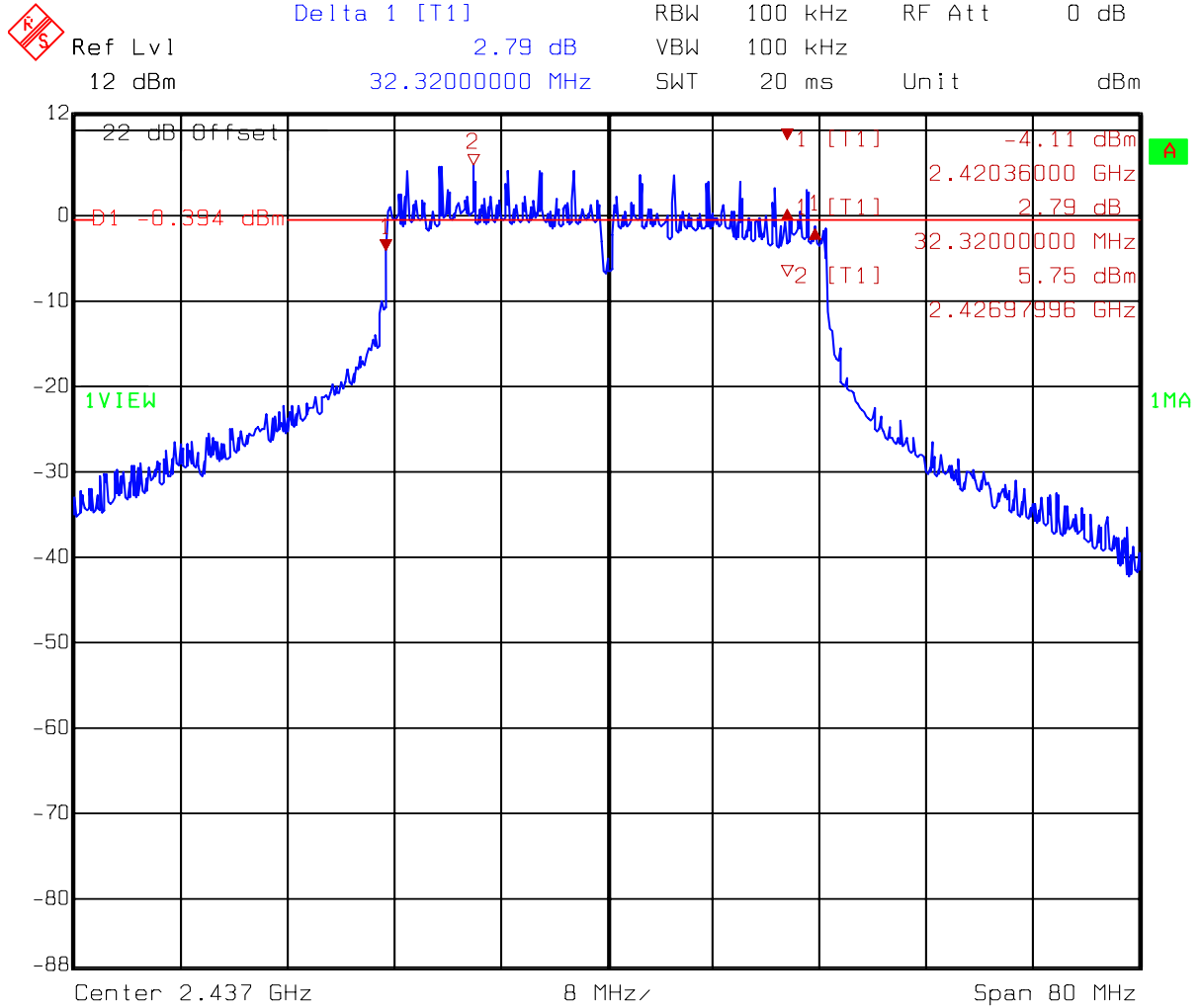

Title: 6dB Band-Width
 Comment A: CH 6 at 802.11g mode (Turbo mode)
 Date: 25.JAN.2007 18:13:53

4. Maximum Output Power test

4.1 Operating environment

Temperature: 23
 Relative Humidity: 55 %
 Atmospheric Pressure: 1023 hPa

4.2 Test setup & procedure

The power output per FCC §15.247(b) was measured on the EUT using a 50 ohm SMA cable connected to peak power meter via power sensor. Power was read directly and cable loss correction (1.5 dB) was added to the reading to obtain power at the EUT antenna terminals. The test was performed at 3 channels (lowest, middle and highest channel).

4.3 Measured data of Maximum Output Power test results

Test Mode: 802.11b

Channel	Freq. (MHz)	C.L. (dB)	Reading (dBm)	Conducted Peak Output Power		Limit (dBm)
				(dBm)	(mW)	
1 (lowest)	2412	2	15.81	17.81	60.40	30
6 (middle)	2437	2	17.58	19.58	90.78	30
11 (highest)	2462	2	17.48	19.48	88.72	30

Test Mode: 802.11g normal mode

Channel	Freq. (MHz)	C.L. (dB)	Reading (dBm)	Conducted Peak Output Power		Limit (W)
				(dBm)	(mW)	
1 (lowest)	2412	2	20.89	22.89	194.54	30
6 (middle)	2437	2	20.97	22.97	198.15	30
11 (highest)	2462	2	21.01	23.01	199.99	30

Test Mode: 802.11g turbo mode

Channel	Freq. (MHz)	C.L. (dB)	Reading (dBm)	Conducted Peak Output Power		Limit (W)
				(dBm)	(mW)	
6 (middle)	2437	2	20.51	22.51	178.24	30

Remark: Conducted Peak Output Power = Reading + C.L.

5. RF Antenna Conducted Spurious test

5.1 Operating environment

Temperature: 25
Relative Humidity: 58 %

5.2 Test setup & procedure

The measurements were performed from 30MHz to 25GHz RF antenna conducted per FCC 15.247 (d) was measured from the EUT antenna port using a 50ohm spectrum analyzer with the resolution bandwidth set at 100 kHz, and the video bandwidth set at 100 kHz.

Harmonics and spurious noise must be at least 20dB down from the highest emission level within the authorized band as measured with a 100 kHz RBW. The table below is the results from the highest emission for each channel within the authorized band. This table was used to determine the spurious limits for each channel.

5.3 Measured data of the highest RF Antenna Conducted Spurious test result

The test results please see the plot below.

Test Mode: 802.11b mode (CH1)

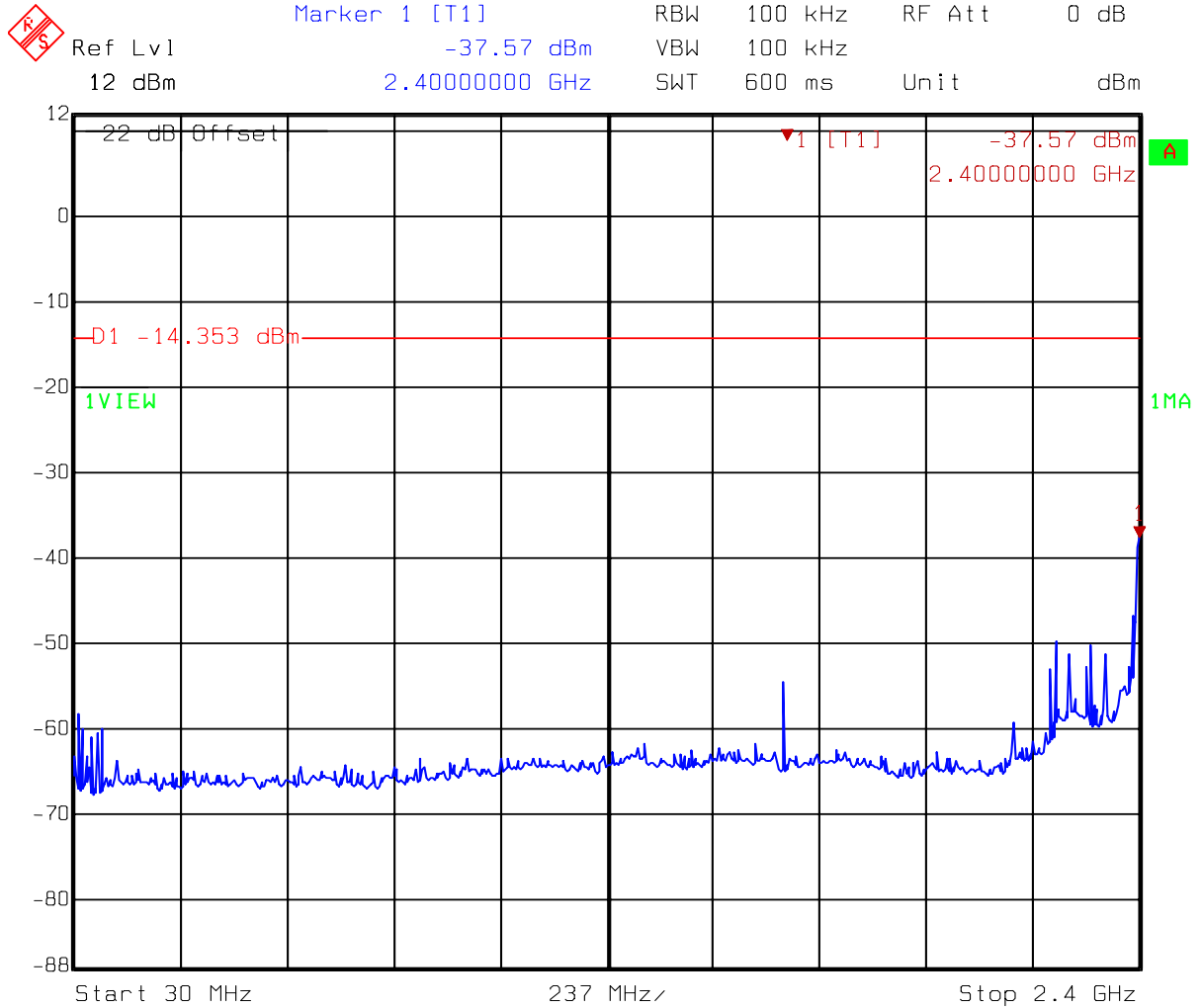

Title: Conductive-Spurious
 Comment A: CH 1 at 802.11b mode 30MHz~2400MHz
 Date: 05.FEB.2007 09:45:00

Test Mode: 802.11b mode (CH1)

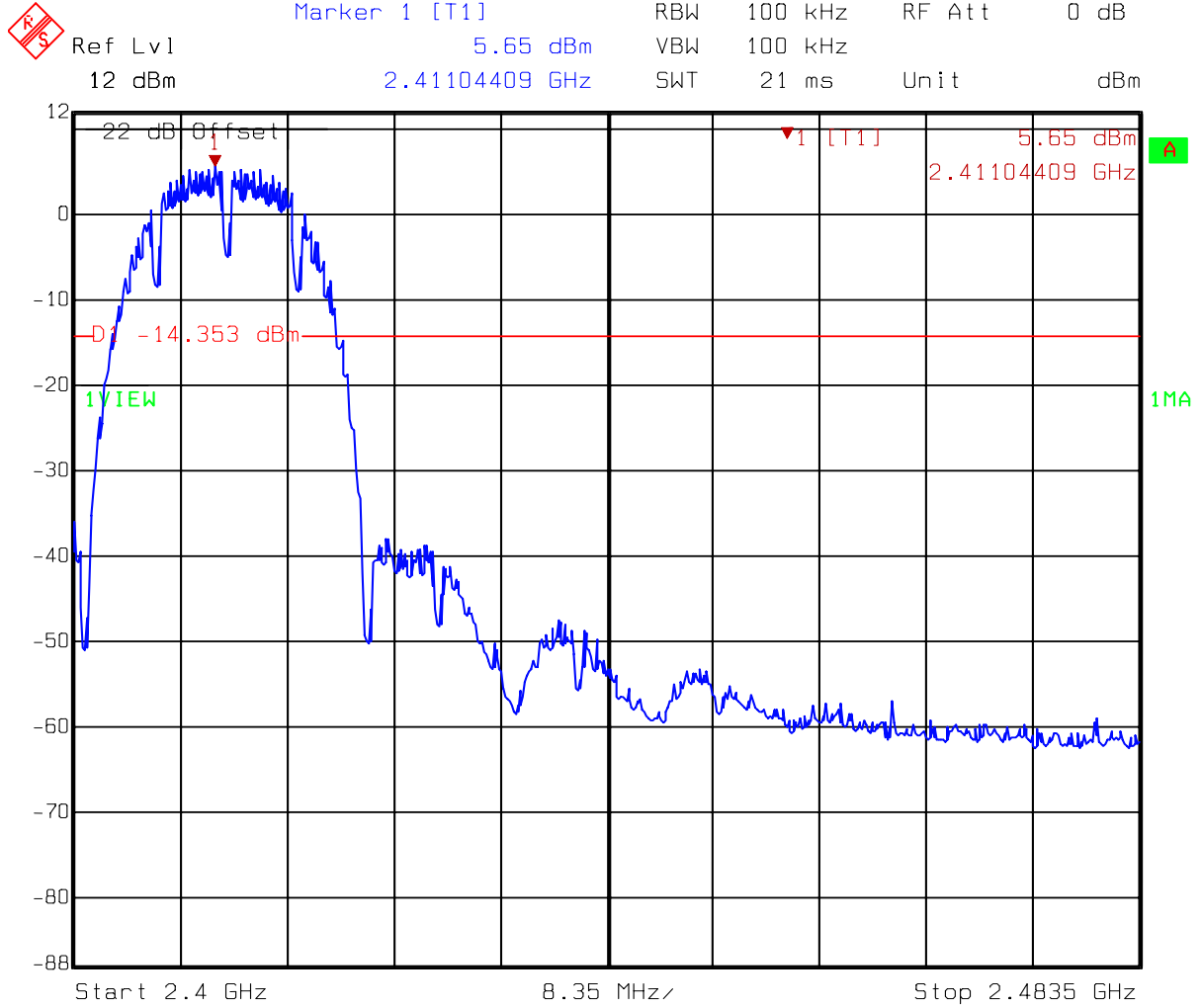

Title: Conductive-Spurious
 Comment A: CH 1 at 802.11b mode 2400MHz~2483.5MHz
 Date: 05.FEB.2007 09:44:39

Test Mode: 802.11b mode (CH1)

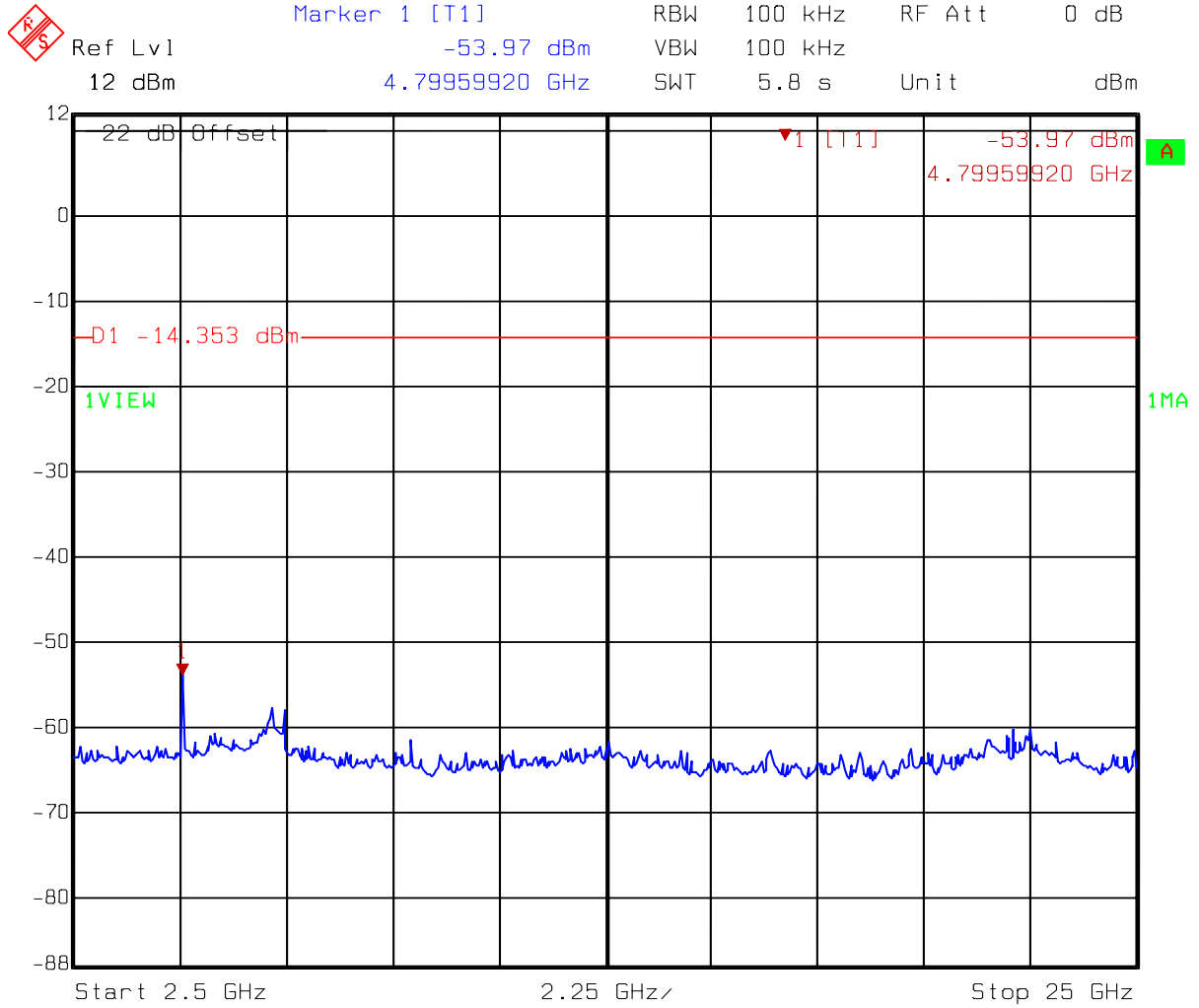

Title: Conductive-Spurious
 Comment A: CH 1 at 802.11b mode 2483.5MHz~25GHz
 Date: 05.FEB.2007 09:45:30

Test Mode: 802.11b mode (CH6)

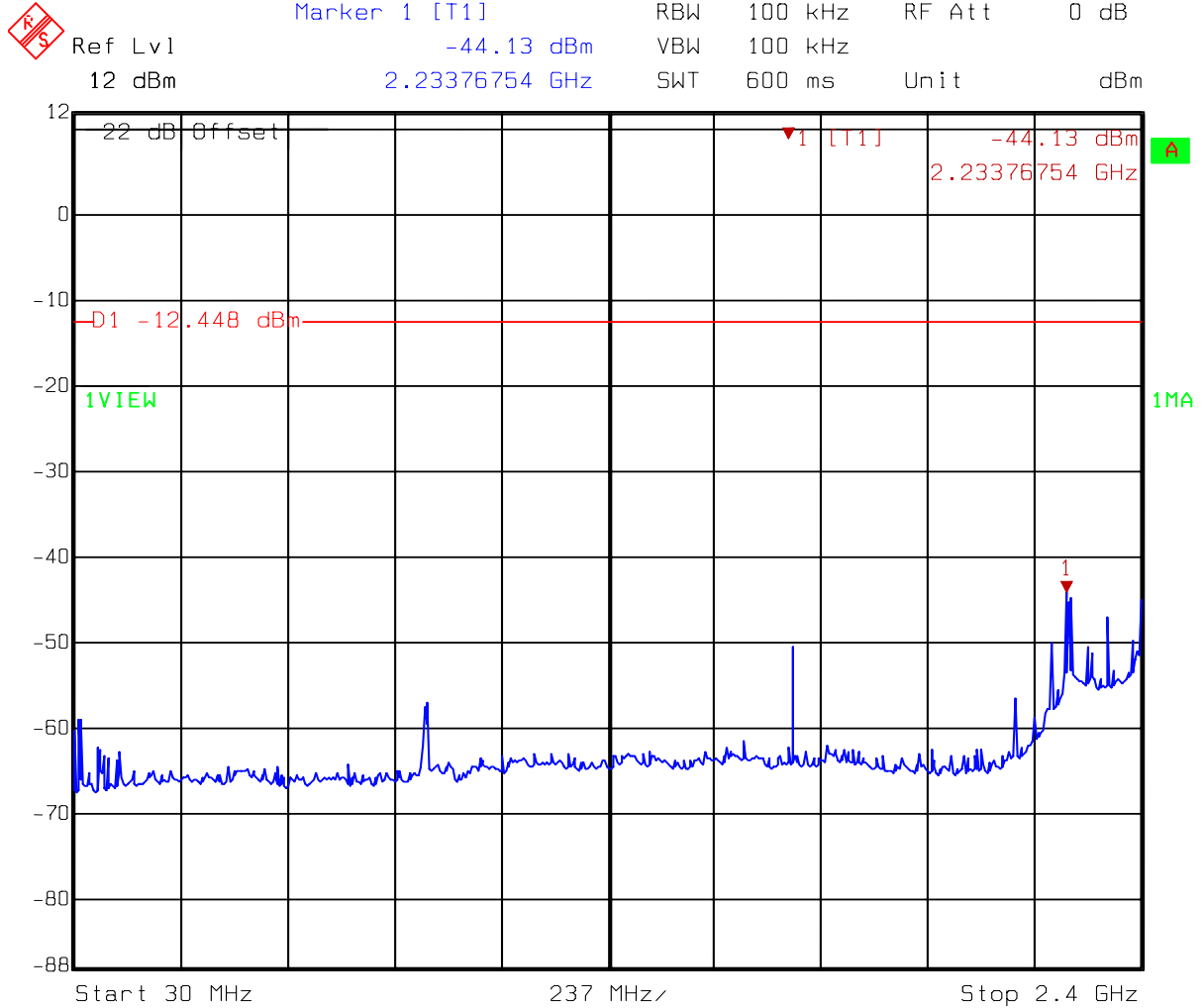

Title: Conductive-Spurious
 Comment A: CH 6 at 802.11b mode 30MHz~2400MHz
 Date: 25.JAN.2007 17:36:23

Test Mode: 802.11b mode (CH6)

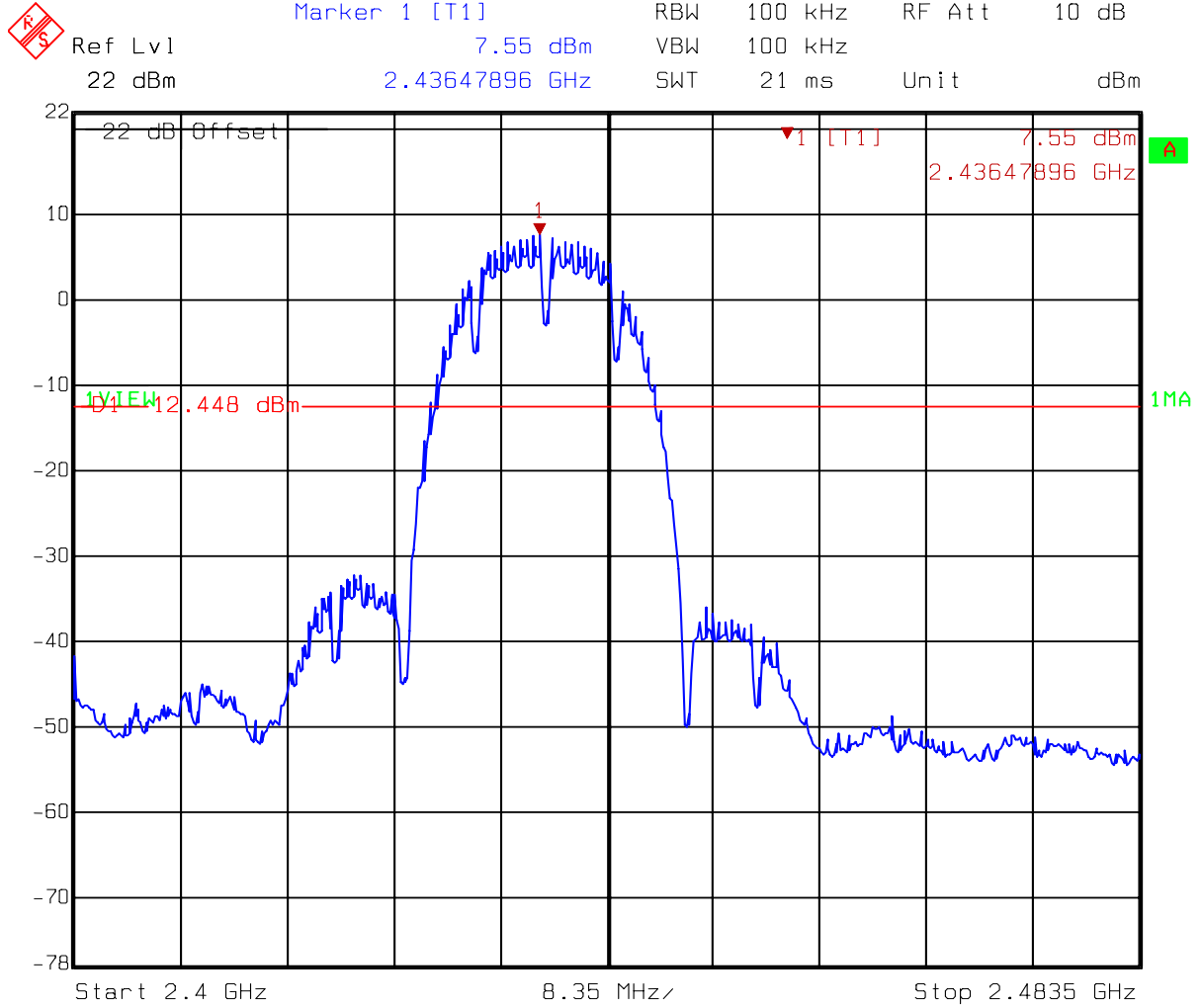

Title: Conductive-Spurious
 Comment A: CH 6 at 802.11b mode 2400MHz~2483.5MHz
 Date: 25.JAN.2007 17:36:01

Test Mode: 802.11b mode (CH6)

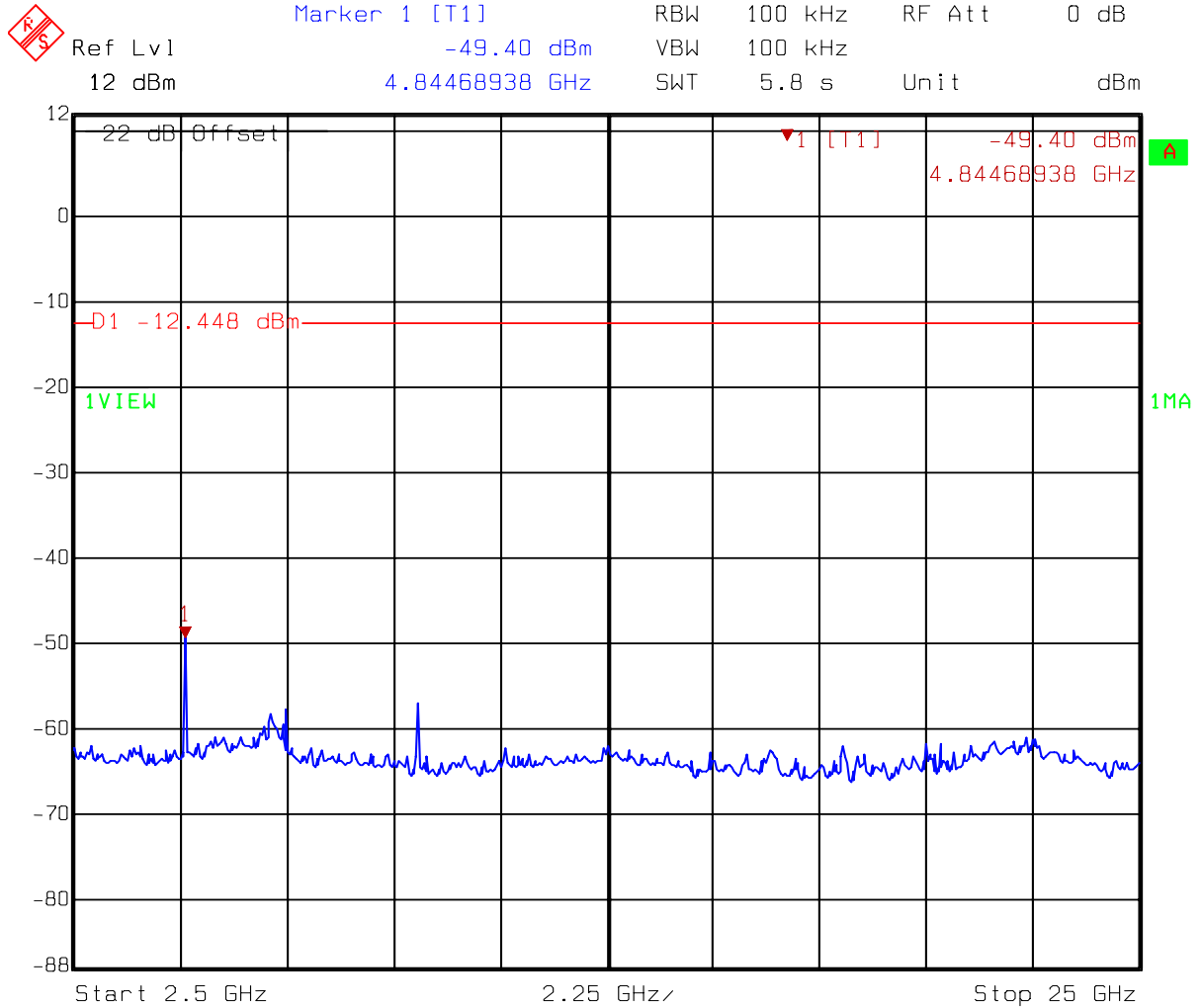

Title: Conductive-Spurious
 Comment A: CH 6 at 802.11b mode 2483.5MHz~25GHz
 Date: 25.JAN.2007 17:36:51

Test Mode: 802.11b mode (CH11)

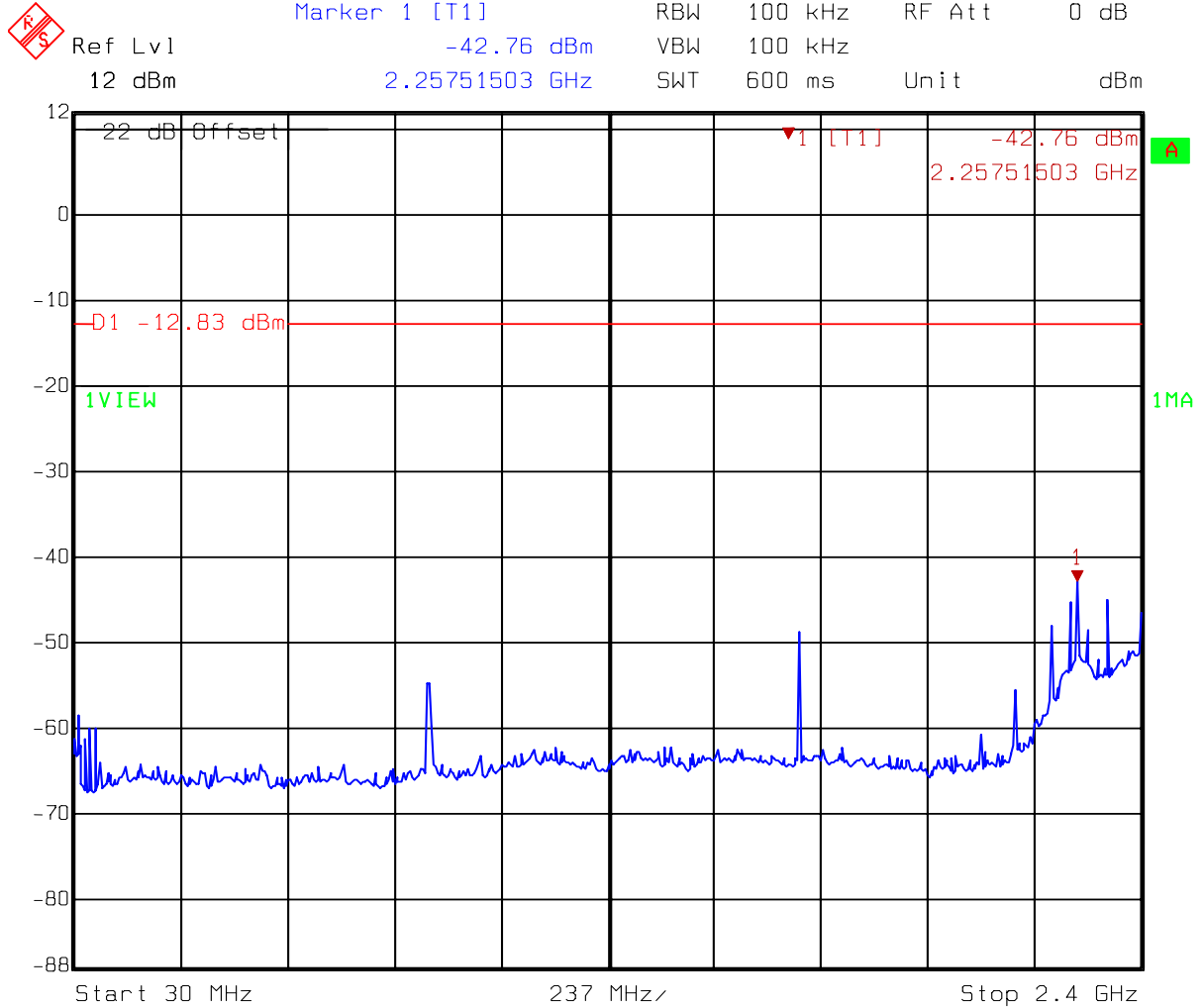

Title: Conductive-Spurious
 Comment A: CH 11 at 802.11b mode 30MHz~2400MHz
 Date: 25.JAN.2007 17:43:09

Test Mode: 802.11b mode (CH11)

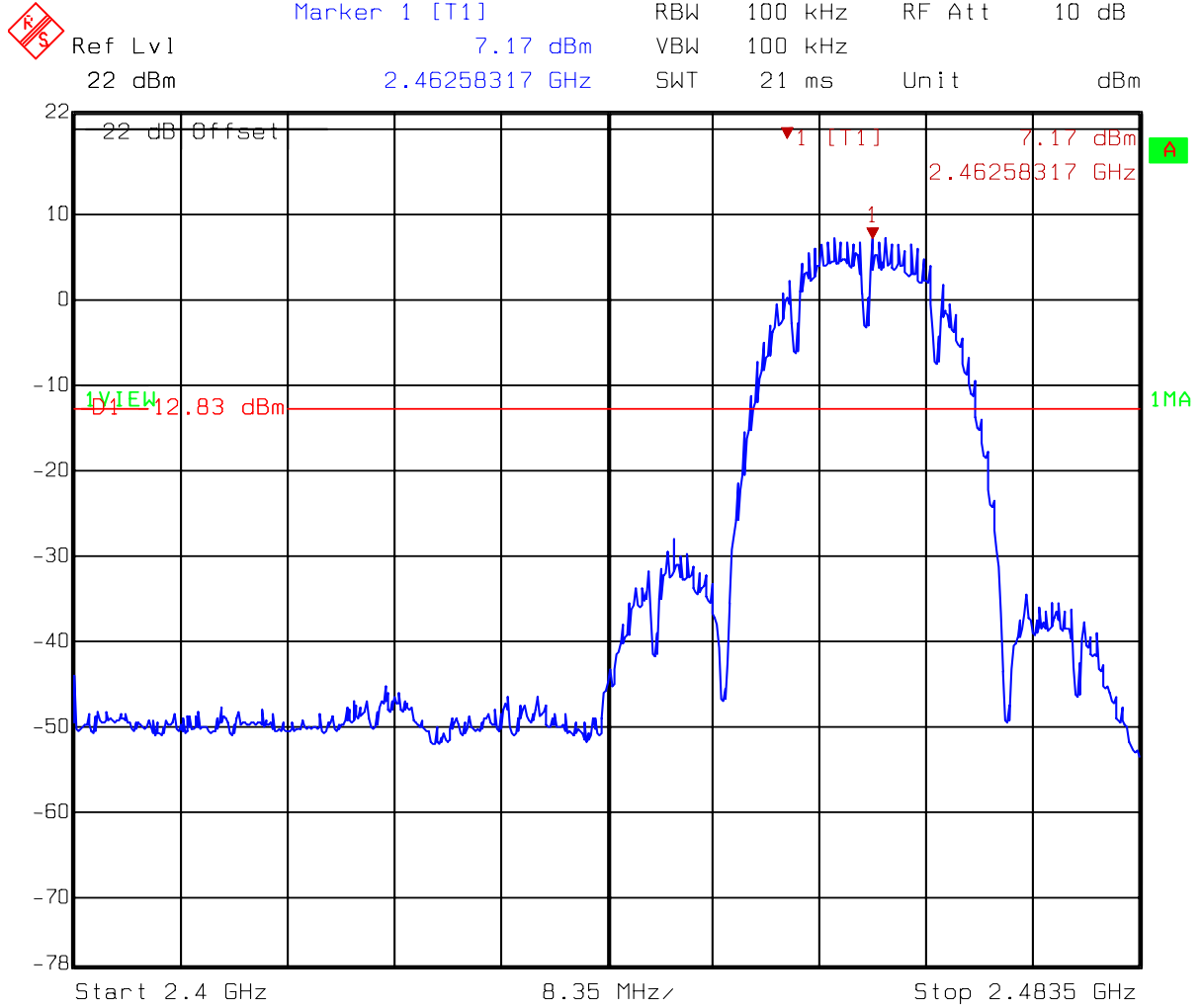

Title: Conductive-Spurious
Comment A: CH 11 at 802.11b mode 2400MHz~2483.5MHz
Date: 25.JAN.2007 17:42:47

Test Mode: 802.11b mode (CH11)

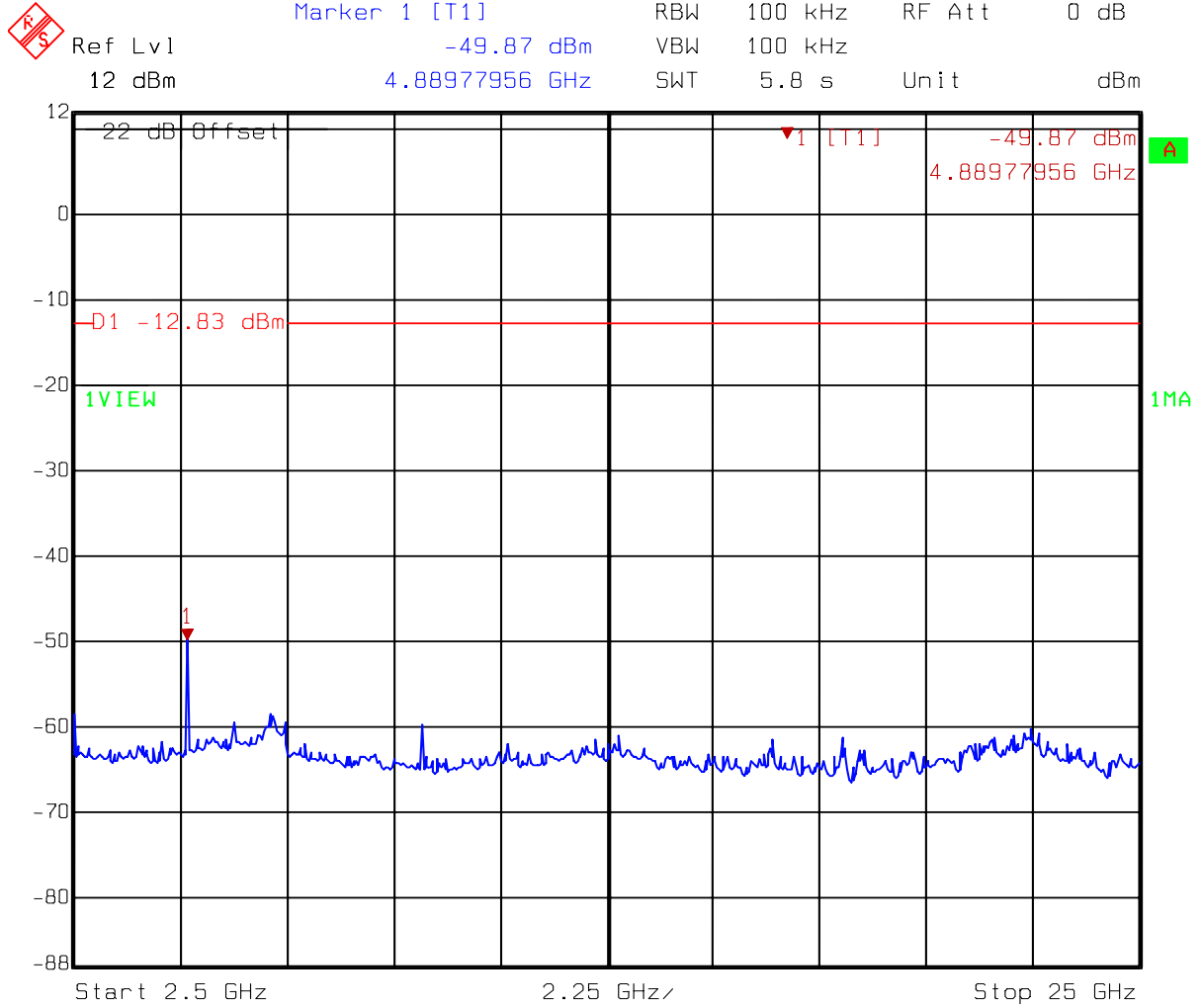

Title: Conductive-Spurious
 Comment A: CH 11 at 802.11b mode 2483.5MHz~25GHz
 Date: 25.JAN.2007 17:43:37

Test Mode: 802.11g normal mode (CH1)

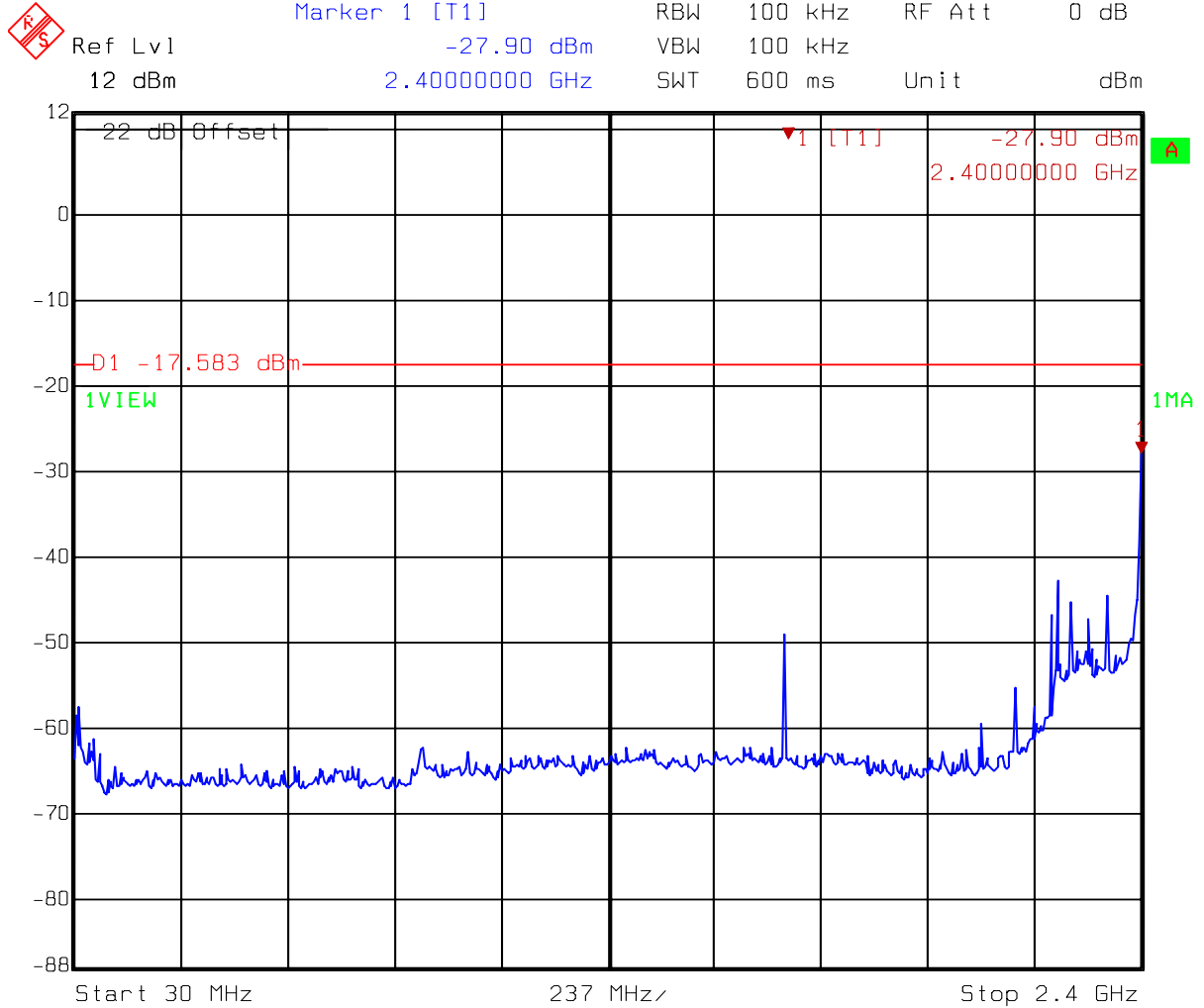

Title: Conductive-Spurious
 Comment A: CH 1 at 802.11g mode 30MHz~2400MHz
 Date: 05.FEB.2007 09:50:23

Test Mode: 802.11g normal mode (CH1)

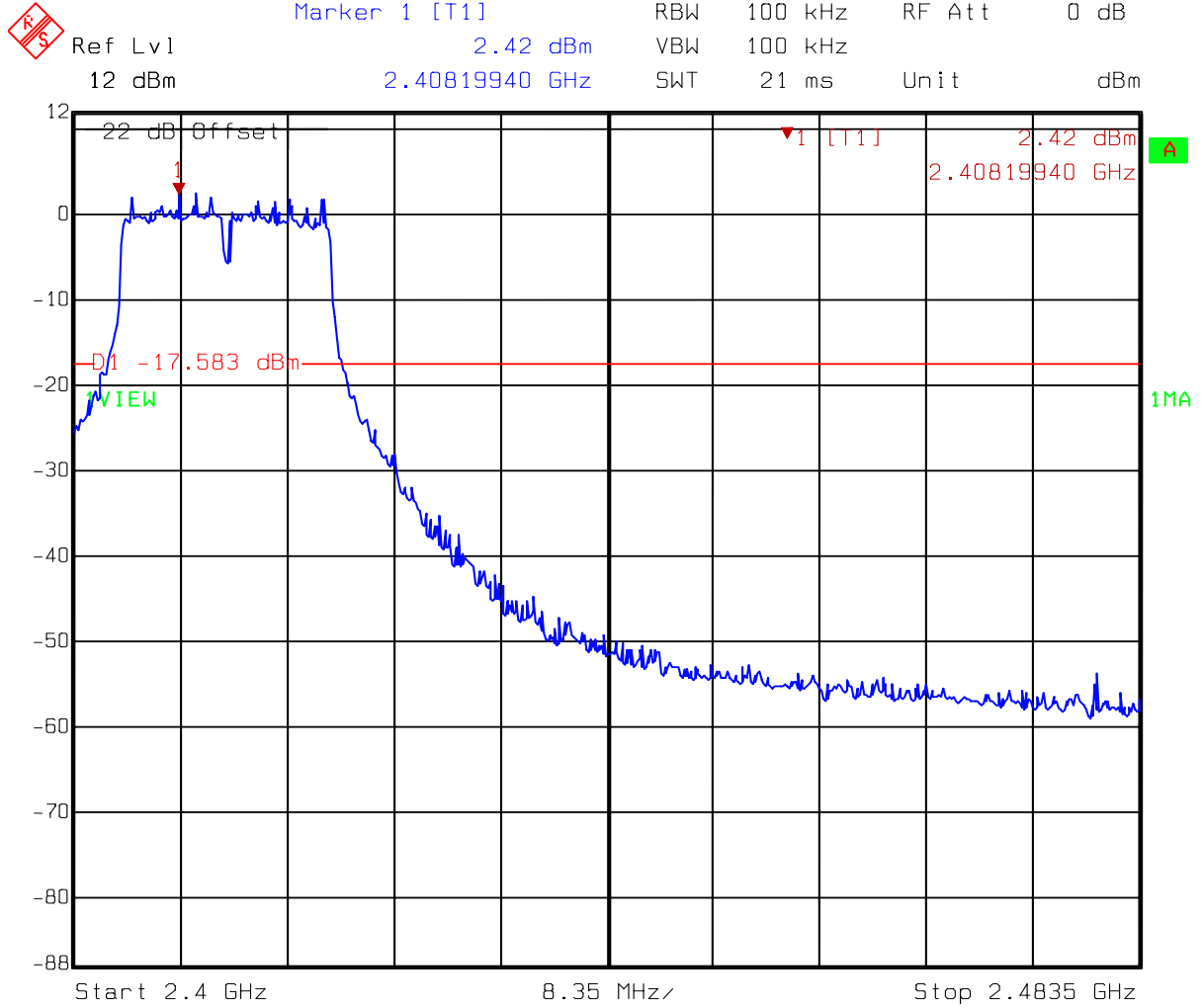

Title: Conductive-Spurious
 Comment A: CH 1 at 802.11g mode 2400MHz~2483.5MHz
 Date: 05.FEB.2007 09:50:01

Test Mode: 802.11g normal mode (CH1)

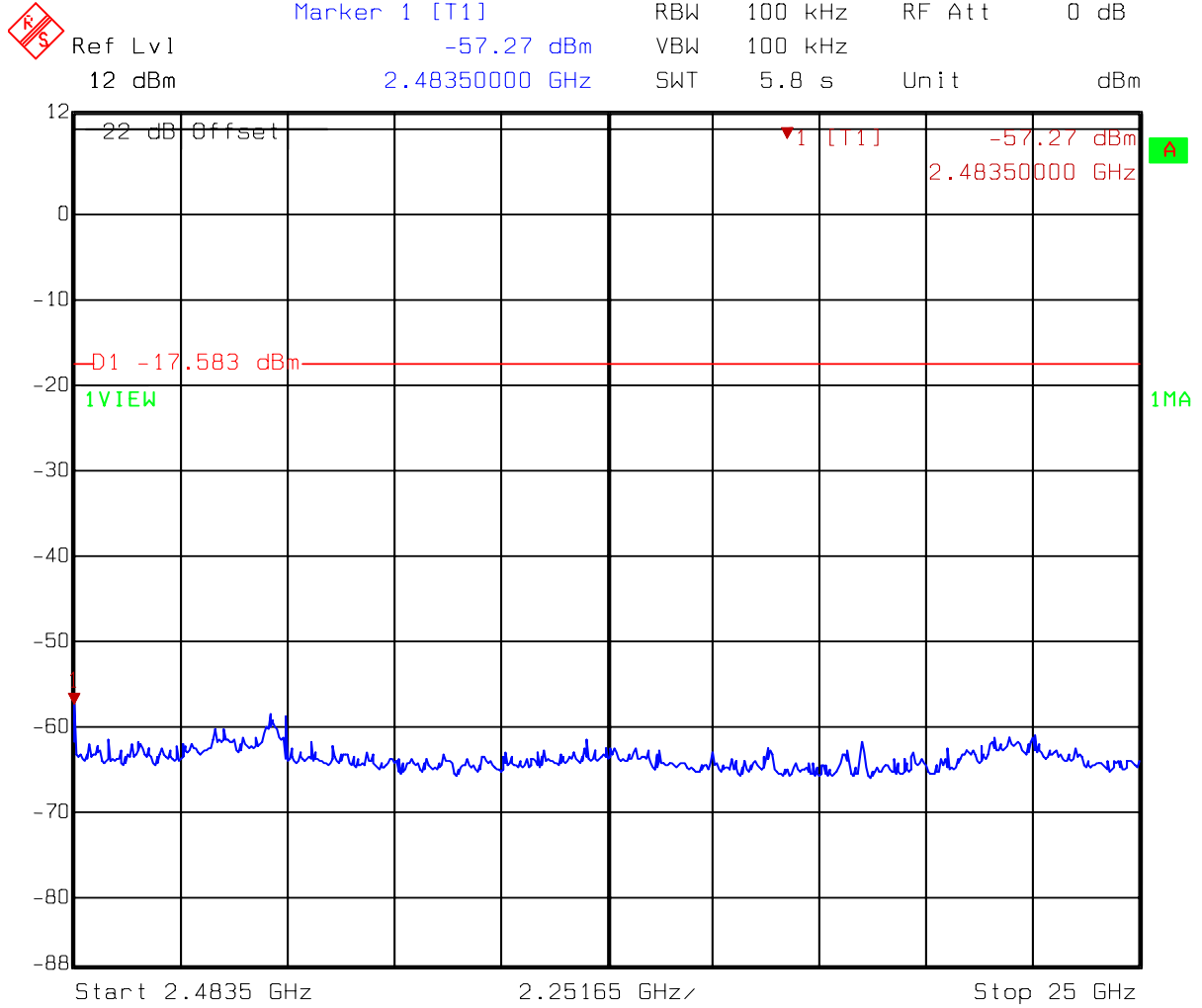

Title: Conductive-Spurious
 Comment A: CH 1 at 802.11g mode 2483.5MHz~25000MHz
 Date: 05.FEB.2007 09:50:50

Test Mode: 802.11g normal mode (CH6)

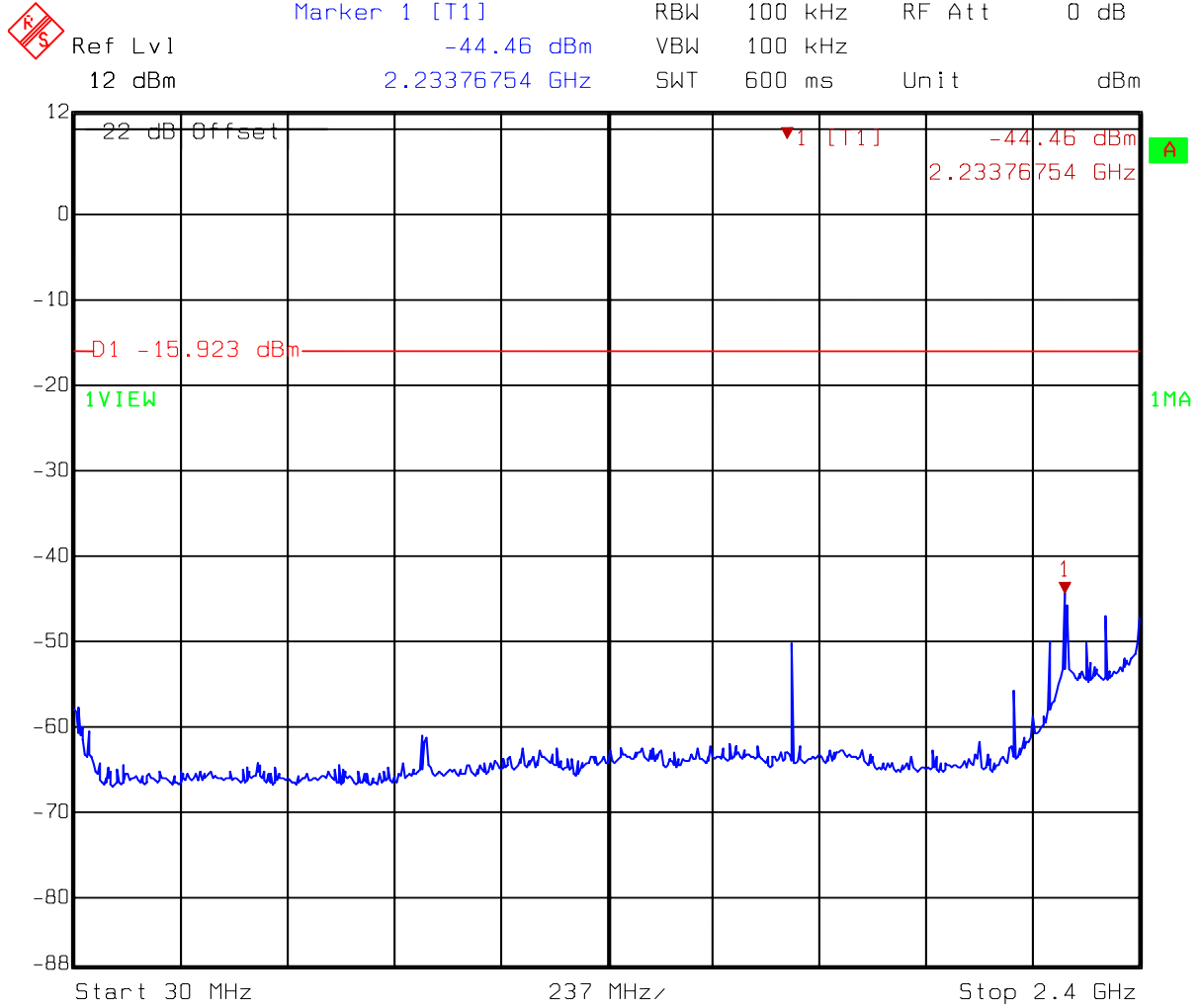

Title: Conductive-Spurious
 Comment A: CH 6 at 802.11g mode 30MHz~2400MHz
 Date: 25.JAN.2007 17:52:30

Test Mode: 802.11g normal mode (CH6)

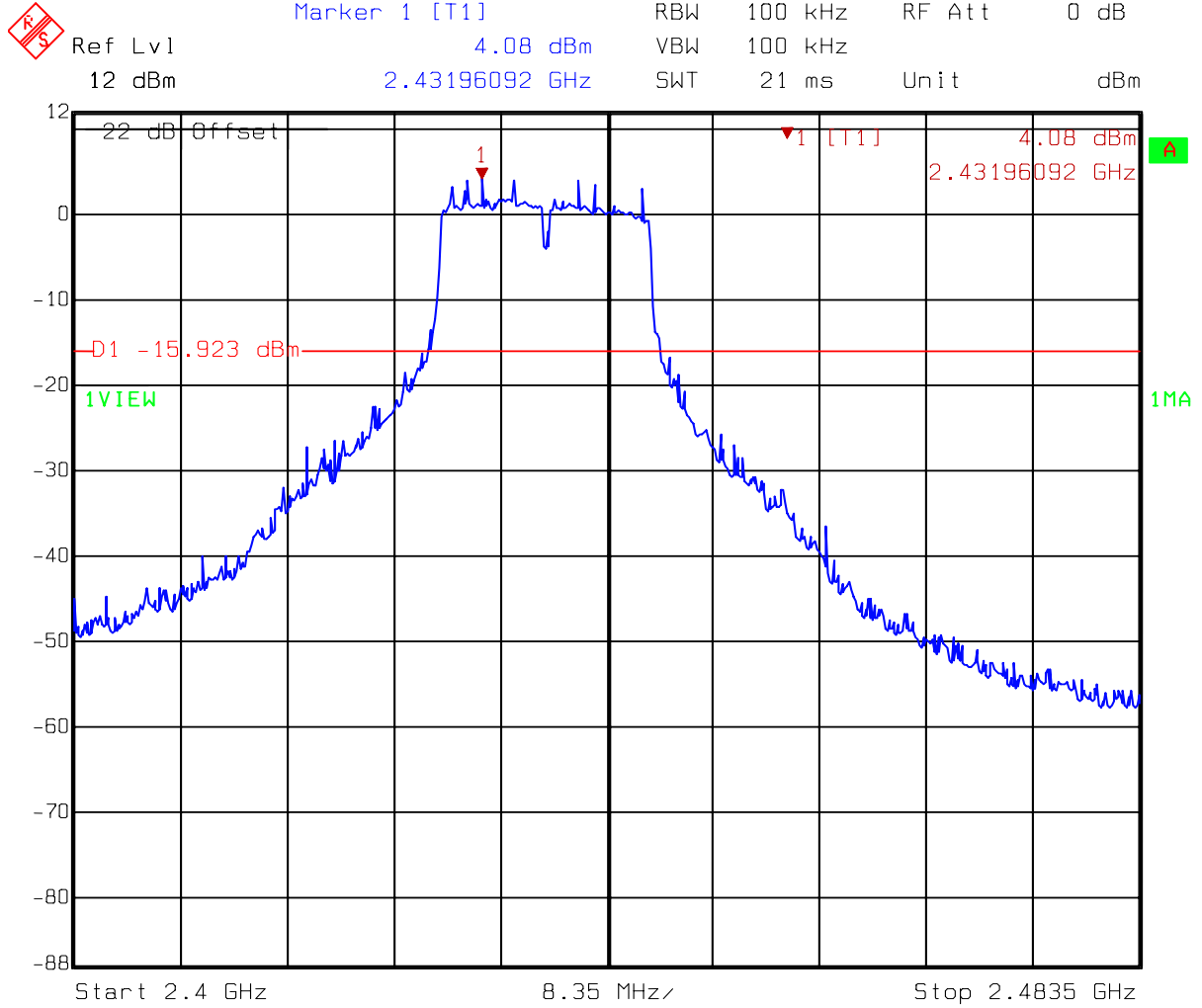

Title: Conductive-Spurious
Comment A: CH 6 at 802.11g mode 2400MHz~2483.5MHz
Date: 25.JAN.2007 17:52:08

Test Mode: 802.11g normal mode (CH6)

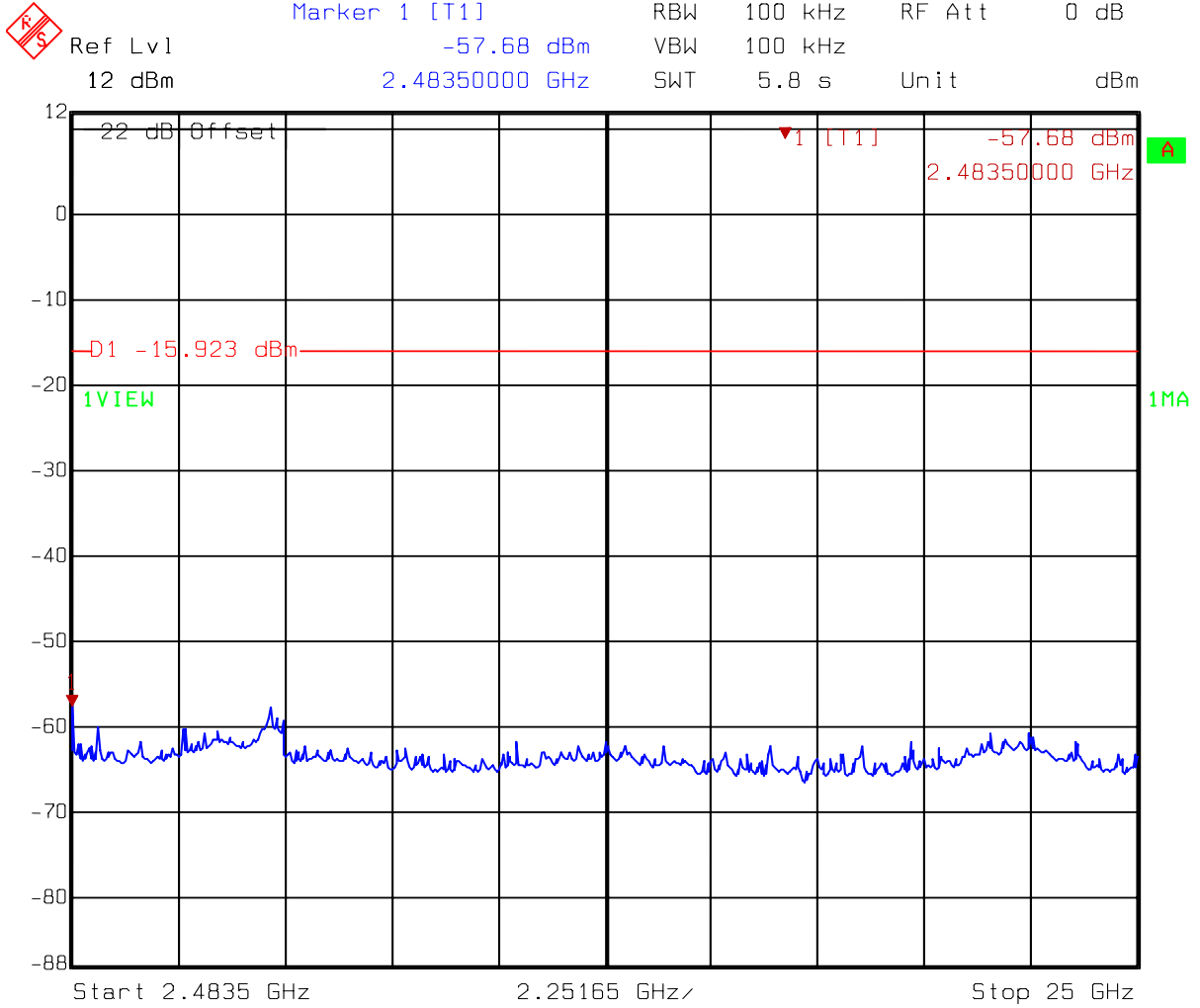

Title: Conductive-Spurious
Comment A: CH 6 at 802.11g mode 2483.5MHz~25000MHz
Date: 25.JAN.2007 17:52:58

Test Mode: 802.11g turbo mode (CH6)

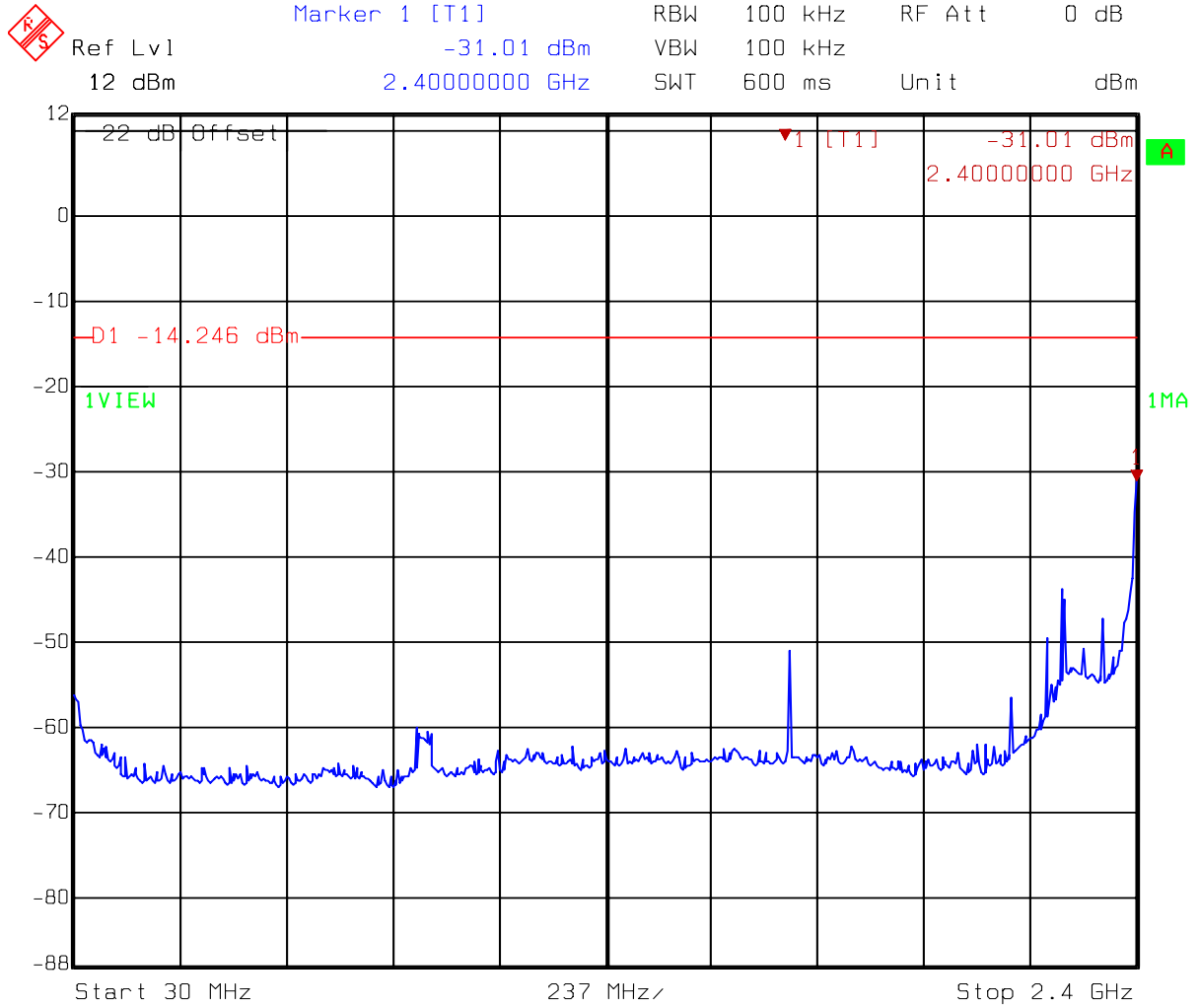

Title: Conductive-Spurious
 Comment A: CH 6 at 802.11g mode 30MHz~2400MHz(Turbo Mode)
 Date: 25.JAN.2007 18:18:29

Test Mode: 802.11g turbo mode (CH6)

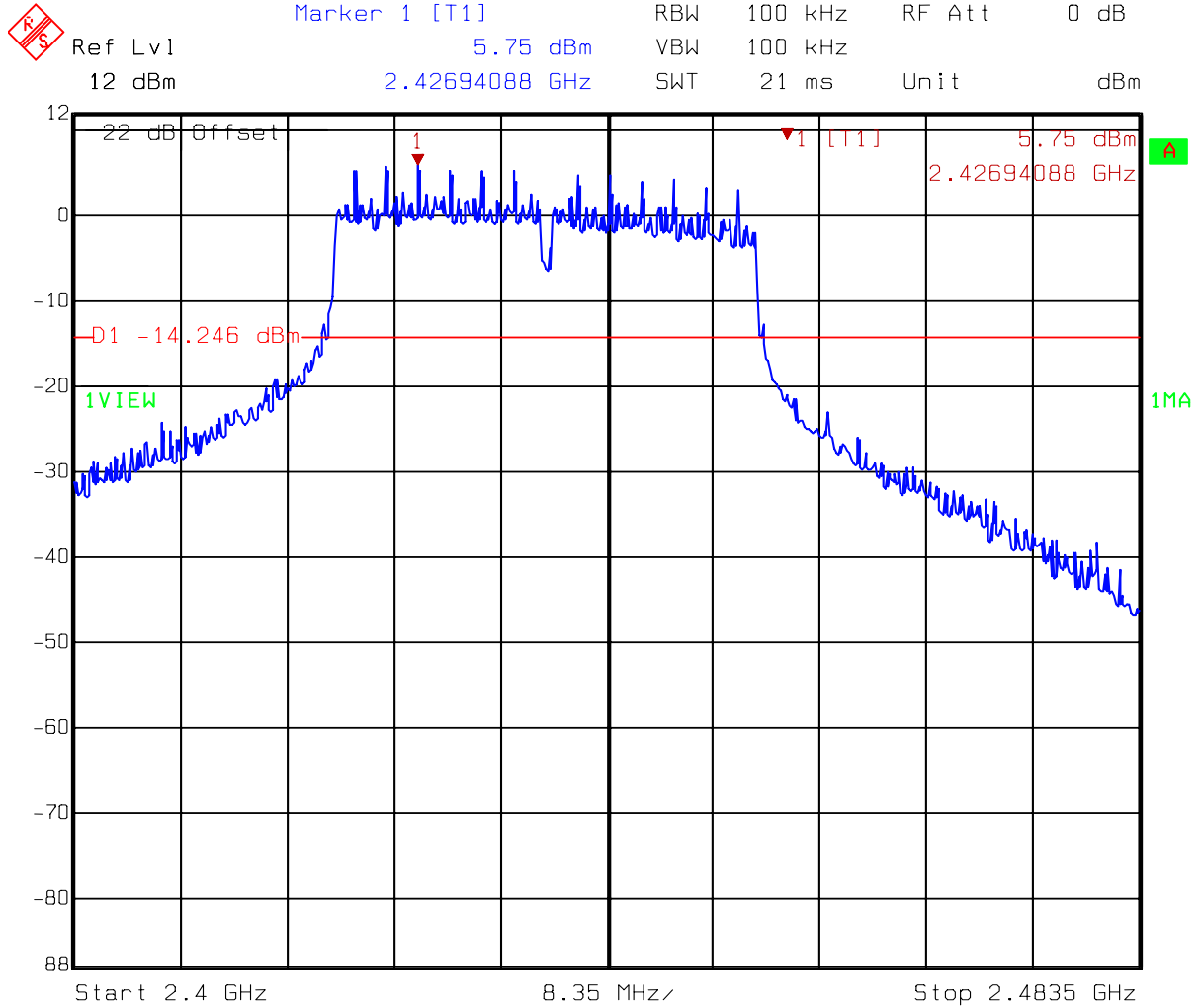

Title: Conductive-Spurious
 Comment A: CH 6 at 802.11g mode 2400MHz~2483.5MHz(Turbo Mode)
 Date: 25.JAN.2007 18:18:07

Test Mode: 802.11g turbo mode (CH6)

	Ref Lvl	Marker 1 [T1]	RBW	100 kHz	RF Att	0 dB
	12 dBm	-49.16 dBm	VBW	100 kHz		
		2.48350000 GHz	SWT	5.8 s	Unit	dBm

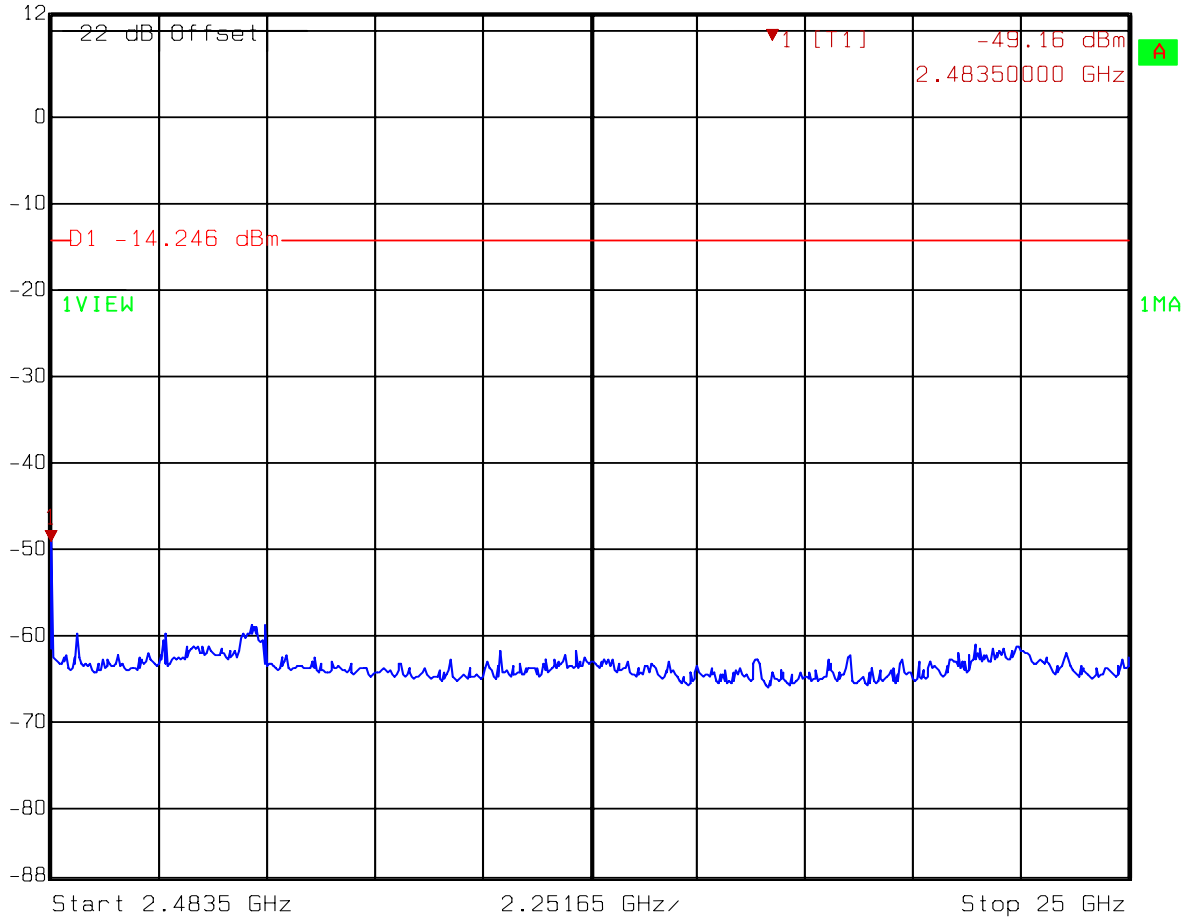

Title: Conductive-Spurious
 Comment A: CH 6 at 802.11g mode 2483.5MHz~25000MHz(Turbo Mode)
 Date: 25.JAN.2007 18:18:57

Test Mode: 802.11g normal mode (CH11)

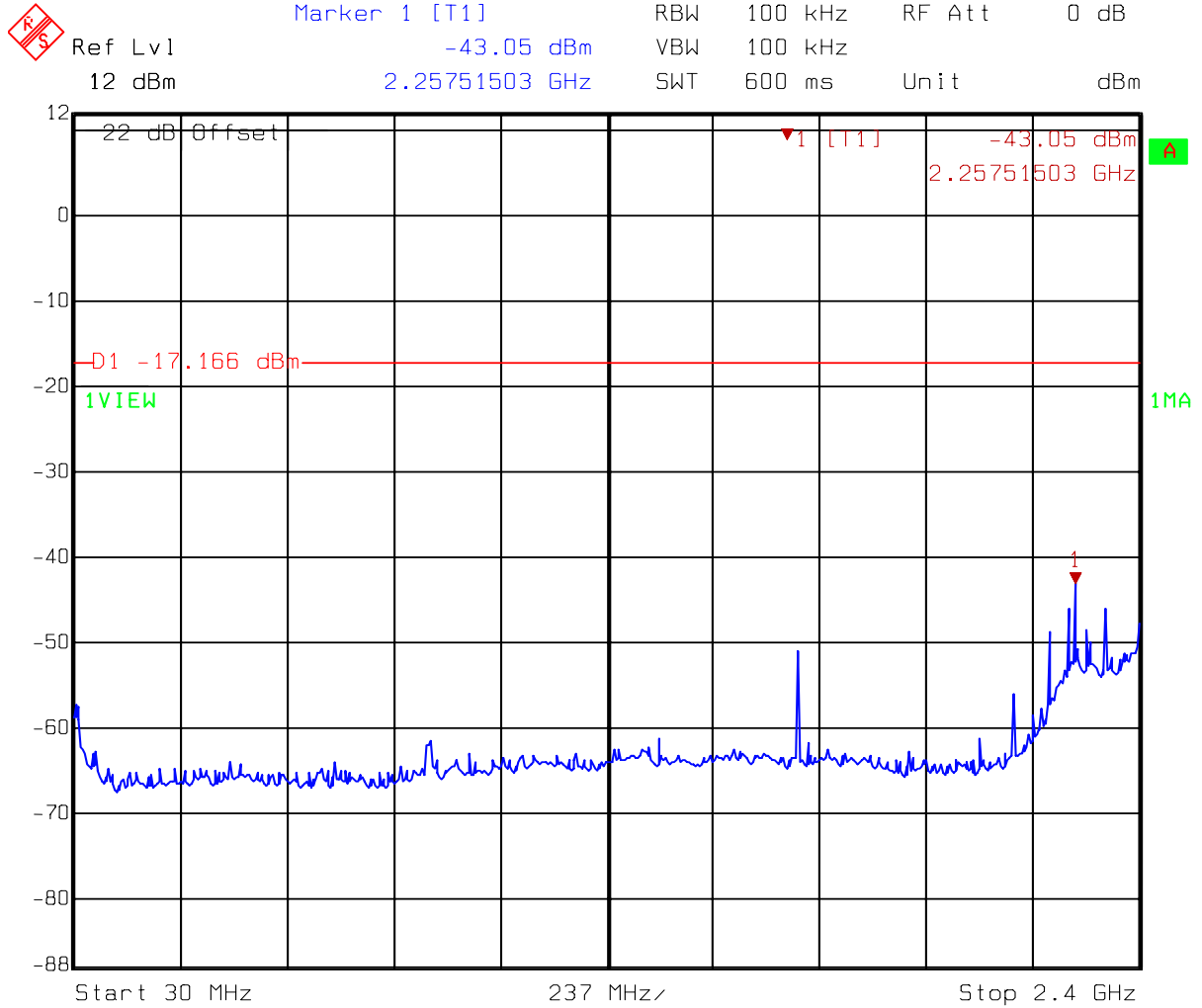

Title: Conductive-Spurious
Comment A: CH 11 at 802.11g mode 30MHz~2400MHz
Date: 05.FEB.2007 12:09:41

Test Mode: 802.11g normal mode (CH11)

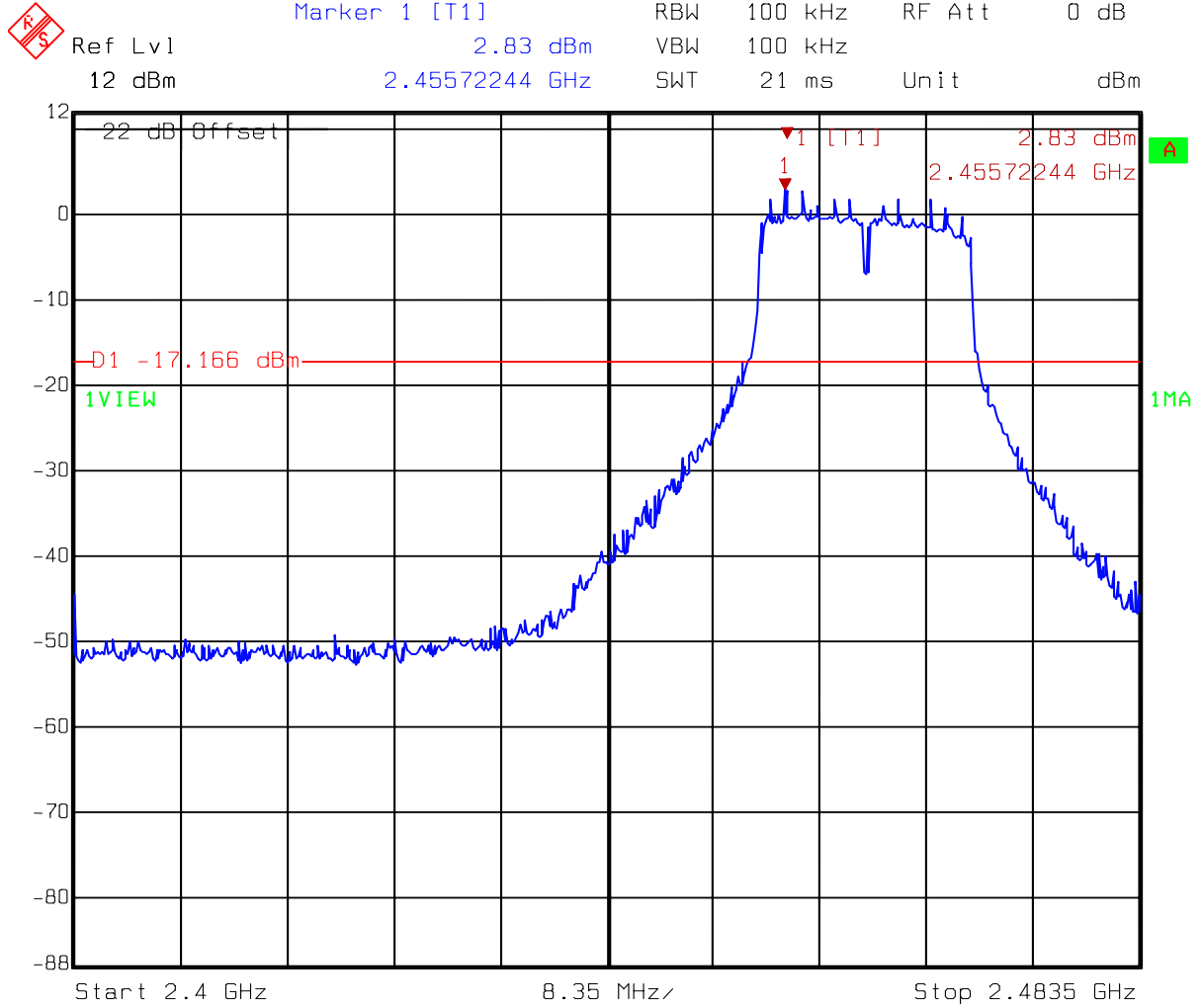

Title: Conductive-Spurious
Comment A: CH 11 at 802.11g mode 2400MHz~2483.5MHz
Date: 05.FEB.2007 12:09:19

Test Mode: 802.11g normal mode (CH11)

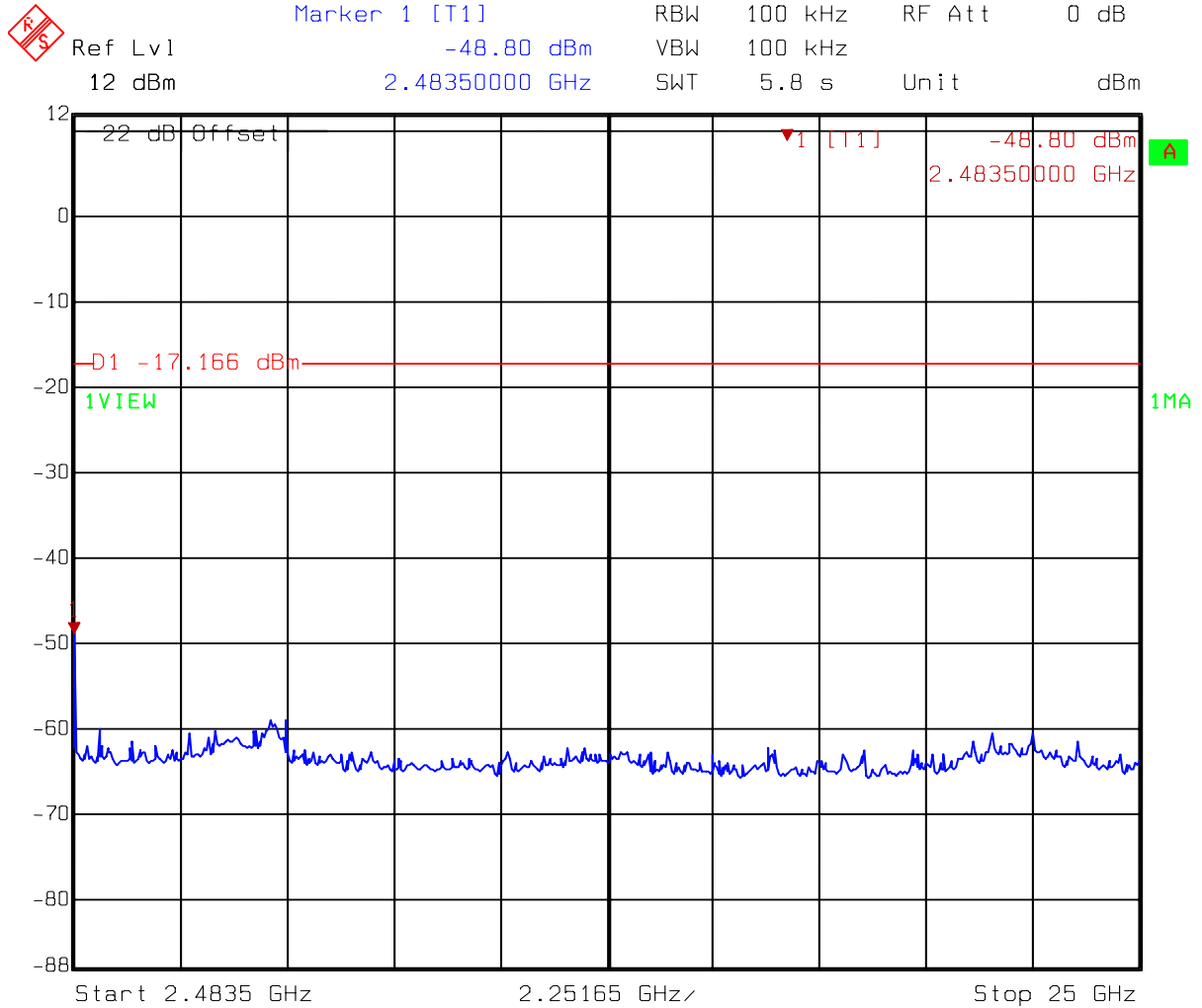

Title: Conductive-Spurious
 Comment A: CH 11 at 802.11g mode 2483.5MHz~25000MHz
 Date: 05.FEB.2007 12:10:09

6. Radiated Emission test

6.1 Operating environment

Temperature: 23
Relative Humidity: 53 %
Atmospheric Pressure: 1023 hPa

6.2 Test setup & procedure

The Diagram below shows the test setup, which is utilized to make these measurements.

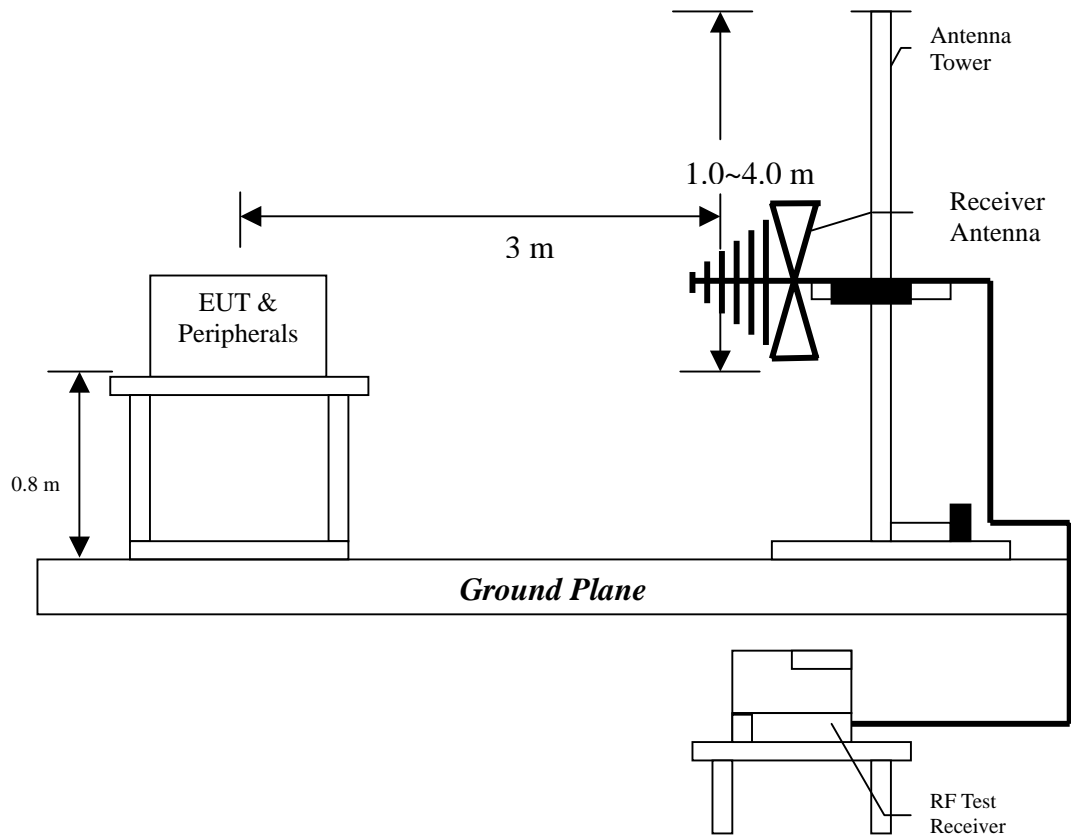

Radiated emissions were investigated cover the frequency range from 30MHz to 1000MHz using a receiver RBW of 120kHz record QP reading, and the frequency over 1GHz using a spectrum analyzer RBW of 1MHz and 10Hz VBW record Average reading. (15.209 paragraph), the Peak reading (1MHz RBW/VBW) recorded also on the report.

The EUT for testing is arranged on a wooden turntable. If some peripherals apply to the EUT, the peripherals will be connected to EUT and the whole system. During the test, all cables were arranged to produce worst-case emissions. The signal is maximized through rotation. The height of antenna and polarization is changing constantly for exploring for maximum signal level. The height of antenna can be up to 4 meters and down to 1 meter.

The measurement for radiated emission will be done at the distance of three meters unless the signal level is too low to measure at that distance. In the case of the reading under noise floor, a pre-amplifier is used and/or the test is conducted at a closer distance. And then all readings are extrapolated back to the equivalent 3 meter reading using inverse scaling with distance.

The EUT configuration please refer to the “Spurious set-up photo.pdf”.

6.3 Emission limits

The spurious Emission shall test through the 10th harmonic. In addition, radiated emissions which fall in the restricted bands, as defined in §15.205(a), must also comply with the radiated emission limits specified in §15.209(a).

Frequency (MHz)	Limits (dB μ V/m@3m)
30-88	40
88-216	43.5
216-960	46
Above 960	54

Remark:

1. In the above table, the tighter limit applies at the band edges.
2. Distance refers to the distance in meters between the measuring instrument antenna and the closed point of any part of the device or system

Uncertainty was calculated in accordance with NAMAS NIS 81.

Expanded uncertainty (k=2) of radiated emission measurement is 4.98 dB.

6.4 Radiated spurious emission test data

6.4.1 Measurement results: frequencies equal to or less than 1 GHz

The test was performed on EUT under 802.11b and 802.11g continuously transmitting mode. Channel 1, 6, 11 were verified. The worst case occurred at 802.11b Tx channel 1.

EUT : NWD-670S
 Worst Case : 802.11b Tx at channel 1

Antenna Polariz. (V/H)	Freq. (MHz)	Receiver Detector	Corr. Factor (dB/m)	Reading (dBuV)	Corrected Level (dBuV/m)	Limit @ 3 m (dBuV/m)	Margin (dB)
V	99.840	QP	12.90	7.38	25.70	33.08	43.50
V	165.800	QP	11.39	15.70	25.37	41.07	43.50
V	231.760	QP	12.22	12.18	21.76	33.94	46.00
V	365.620	QP	17.68	15.06	25.72	40.78	46.00
V	398.600	QP	18.43	16.40	16.11	32.51	46.00
V	759.440	QP	19.46	22.81	15.47	38.28	46.00
H	165.800	QP	13.84	24.58	38.42	43.50	-5.09
H	231.760	QP	11.74	31.45	43.19	46.00	-2.81
H	365.620	QP	15.48	23.65	39.13	46.00	-6.88
H	569.320	QP	19.72	16.41	36.13	46.00	-9.87
H	740.040	QP	22.95	17.74	40.69	46.00	-5.31
H	761.380	QP	23.02	16.39	39.41	46.00	-6.59

Remark:

1. Corr. Factor = Antenna Factor + Cable Loss
2. Corrected Level = Reading + Corr. Factor

6.4.2 Measurement results: frequency above 1GHz

EUT : NWD-670S
Test Condition : 802.11b Tx at channel 1

Frequency (MHz)	Spectrum Analyzer Detector	Antenna Polariz. (H/V)	Preamp. Gain (dB)	Correction Factor (dB/m)	Reading (dBuV)	Corrected Level (dBuV/m)	Limit @ 3 m (dBuV/m)	Margin (dB)
3000.00	PK	V	35.54	34.62	43.05	42.13	54	-11.87
3210.00	PK	V	35.54	34.62	43.83	42.91	54	-11.09
3030.00	PK	H	35.54	34.62	42.14	41.22	54	-12.78
3210.00	PK	H	35.54	34.62	40.89	39.97	54	-14.03

Remark:

1. Correction Factor = Antenna Factor + Cable Loss
2. Corrected Level = Reading + Correction Factor – Preamp. Gain
3. The frequency measured ranges from 1GHz to 25GHz. The data value listed above which is higher than the noise floor, the others please refer to noise floor level.

Noise floor level is :

For PK:

1GHz-3GHz: 20dBuV
3GHz-14GHz: 27dBuV
14GHz-26.5GHz: 39dBuV

For AV:

1GHz-3GHz: 10dBuV
3GHz-14GHz: 16dBuV
14GHz-26.5GHz: 28dBuV

EUT : NWD-670S
Test Condition : 802.11b Tx at channel 6

Frequency (MHz)	Spectrum Analyzer Detector	Antenna Polariz. (H/V)	Preamp. Gain (dB)	Correction Factor (dB/m)	Reading (dBuV)	Corrected Level (dBuV/m)	Limit @ 3 m (dBuV/m)	Margin (dB)
3090.00	PK	V	35.54	34.62	42.53	41.61	54	-12.39
3240.00	PK	V	35.54	34.62	46.08	45.16	54	-8.84
3240.00	PK	H	35.54	34.62	42.19	41.27	54	-12.73

Remark:

1. Correction Factor = Antenna Factor + Cable Loss
2. Corrected Level = Reading + Correction Factor – Preamp. Gain
3. The frequency measured ranges from 1GHz to 25GHz. The data value listed above which is higher than the noise floor, the others please refer to noise floor level.

Noise floor level is:

For PK:

- 1GHz-3GHz: 20dBuV
- 3GHz-14GHz: 27dBuV
- 14GHz-26.5GHz: 39dBuV

For AV:

- 1GHz-3GHz: 10dBuV
- 3GHz-14GHz: 16dBuV
- 14GHz-26.5GHz: 28dBuV

EUT : NWD-670S
Test Condition : 802.11b Tx at channel 11

Frequency (MHz)	Spectrum Analyzer Detector	Antenna Polariz. (H/V)	Preamp. Gain (dB)	Correction Factor (dB/m)	Reading (dBuV)	Corrected Level (dBuV/m)	Limit @ 3 m (dBuV/m)	Margin (dB)
3030.00	PK	V	35.54	34.62	49.13	48.21	54	-5.79
3270.00	PK	V	35.54	34.62	45.79	44.87	54	-9.13
3030.00	PK	H	35.54	34.62	50.07	49.15	54	-4.85
3270.00	PK	H	35.54	34.62	44.33	43.41	54	-10.59

Remark:

1. Correction Factor = Antenna Factor + Cable Loss
2. Corrected Level = Reading + Correction Factor – Preamp. Gain
3. The frequency measured ranges from 1GHz to 25GHz. The data value listed above which is higher than the noise floor, the others please refer to noise floor level.

Noise floor level is:

For PK:

- 1GHz-3GHz: 20dBuV
- 3GHz-14GHz: 27dBuV
- 14GHz-26.5GHz: 39dBuV

For AV:

- 1GHz-3GHz: 10dBuV
- 3GHz-14GHz: 16dBuV
- 14GHz-26.5GHz: 28dBuV

EUT : NWD-670S
 Test Condition : 802.11g Tx at channel 1

Frequency (MHz)	Spectrum Analyzer Detector	Antenna Polariz. (H/V)	Preamp. Gain (dB)	Correction Factor (dB/m)	Reading (dBuV)	Corrected Level (dBuV/m)	Limit @ 3 m (dBuV/m)	Margin (dB)
3030.00	PK	V	35.54	34.62	49.07	48.15	54	-5.85
3210.00	PK	V	35.54	34.62	49.45	48.53	54	-5.47
7236.00	PK	V	36.18	43.97	31.55	39.34	54	-14.66
3030.00	PK	H	35.54	34.62	47.39	46.47	54	-7.53
3210.00	PK	H	35.54	34.62	46.76	45.84	54	-8.16

Remark:

1. Correction Factor = Antenna Factor + Cable Loss
2. Corrected Level = Reading + Correction Factor – Preamp. Gain
3. The frequency measured ranges from 1GHz to 25GHz. The data value listed above which is higher than the noise floor, the others please refer to noise floor level.

Noise floor level is :

For PK:

- 1GHz-3GHz: 20dBuV
- 3GHz-14GHz: 27dBuV
- 14GHz-26.5GHz: 39dBuV

For AV:

- 1GHz-3GHz: 10dBuV
- 3GHz-14GHz: 16dBuV
- 14GHz-26.5GHz: 28dBuV

EUT : NWD-670S
 Test Condition : 802.11g Tx at channel 6

Frequency (MHz)	Spectrum Analyzer Detector	Antenna Polariz. (H/V)	Preamp. Gain (dB)	Correction Factor (dB/m)	Reading (dBuV)	Corrected Level (dBuV/m)	Limit @ 3 m (dBuV/m)	Margin (dB)
3030.00	PK	V	35.54	34.62	53.15	52.23	54	-1.77
3240.00	PK	V	35.54	34.62	50.08	49.16	54	-4.84
3030.00	PK	H	35.54	34.62	49.25	48.33	54	-5.67
3240.00	PK	H	35.54	34.62	47.85	46.93	54	-7.07

Remark:

1. Correction Factor = Antenna Factor + Cable Loss
2. Corrected Level = Reading + Correction Factor – Preamp. Gain
3. The frequency measured ranges from 1GHz to 25GHz. The data value listed above which is higher than the noise floor, the others please refer to noise floor level.

Noise floor level is:

For PK:

- 1GHz-3GHz: 20dBuV
- 3GHz-14GHz: 27dBuV
- 14GHz-26.5GHz: 39dBuV

For AV:

- 1GHz-3GHz: 10dBuV
- 3GHz-14GHz: 16dBuV
- 14GHz-26.5GHz: 28dBuV

EUT : NWD-670S
Test Condition : 802.11g Tx at channel 11

Frequency (MHz)	Spectrum Analyzer Detector	Antenna Polariz. (H/V)	Preamp. Gain (dB)	Correction Factor (dB/m)	Reading (dBuV)	Corrected Level (dBuV/m)	Limit @ 3 m (dBuV/m)	Margin (dB)
3030.00	PK	V	35.54	34.62	53	52.08	54	-1.92
3270.00	PK	V	35.54	34.62	46.74	45.82	54	-8.18
3030.00	PK	H	35.54	34.62	50.85	49.93	54	-4.07
3270.00	PK	H	35.54	34.62	45.36	44.44	54	-9.56

Remark:

1. Correction Factor = Antenna Factor + Cable Loss
2. Corrected Level = Reading + Correction Factor – Preamp. Gain
3. The frequency measured ranges from 1GHz to 25GHz. The data value listed above which is higher than the noise floor, the others please refer to noise floor level.

Noise floor level is:

For PK:

- 1GHz-3GHz: 20dBuV
- 3GHz-14GHz: 27dBuV
- 14GHz-26.5GHz: 39dBuV

For AV:

- 1GHz-3GHz: 10dBuV
- 3GHz-14GHz: 16dBuV
- 14GHz-26.5GHz: 28dBuV

EUT : NWD-670S
 Test Condition : 802.11g Tx at channel 6 (Turbo)

Frequency (MHz)	Spectrum Analyzer Detector	Antenna Polariz. (H/V)	Preamp. Gain (dB)	Correction Factor (dB/m)	Reading (dBuV)	Corrected Level (dBuV/m)	Limit @ 3 m (dBuV/m)	Margin (dB)
3030.00	PK	V	35.54	34.62	57.35	56.43	74	-17.57
3030.00	AV	V	35.54	34.62	31.15	30.23	54	-23.77
3240.00	PK	V	35.54	34.62	45.24	44.32	54	-9.68
3030.00	PK	H	35.54	34.62	51.47	50.55	54	-3.45
3240.00	PK	H	35.54	34.62	44.47	43.55	54	-10.45

Remark:

1. Correction Factor = Antenna Factor + Cable Loss
2. Corrected Level = Reading + Correction Factor – Preamp. Gain
3. The frequency measured ranges from 1GHz to 25GHz. The data value listed above which is higher than the noise floor, the others please refer to noise floor level.

Noise floor level is:

For PK:

- 1GHz-3GHz: 20dBuV
- 3GHz-14GHz: 27dBuV
- 14GHz-26.5GHz: 39dBuV

For AV:

- 1GHz-3GHz: 10dBuV
- 3GHz-14GHz: 16dBuV
- 14GHz-26.5GHz: 28dBuV

7. Power Spectrum Density test

7.1 Operating environment

Temperature: 18
 Relative Humidity: 65 %
 Atmospheric Pressure 1023 hPa

7.2 Test setup & procedure

The power spectrum density per FCC §15.247(e) was measured from the antenna port of the EUT using a 50ohm spectrum analyzer with the resolution bandwidth set at 3kHz, the video bandwidth set at 10kHz, a span of 300kHz, and the sweep time set at 100 seconds. Power Density was read directly correction was added to the reading to obtain power at the EUT antenna terminals. The test was performed at 3 channels (lowest, middle and highest channel). The Power Spectral Density measured result is in the following table.

7.3 Measured data of Power Spectrum Density test results

Test Mode: 802.11b (DSSS Modulation) operating mode

Channel	Frequency (MHz)	Power spectrum density (dBm)	Limit (dBm)
1 (lowest)	2412	-8.19	8
6 (middle)	2437	-6.01	8
11 (highest)	2462	-6.50	8

Test Mode: 802.11g normal mode

Channel	Frequency (MHz)	Power spectrum density (dBm)	Limit (dBm)
1 (lowest)	2412	-9.77	8
6 (middle)	2437	-8.91	8
11 (highest)	2462	-9.23	8

Test Mode: 802.11g turbo mode

Channel	Frequency (MHz)	Power spectrum density (dBm)	Limit (dBm)
6 (middle)	2437	-9.94	8

Please see the plot below.

Test Mode: 802.11b

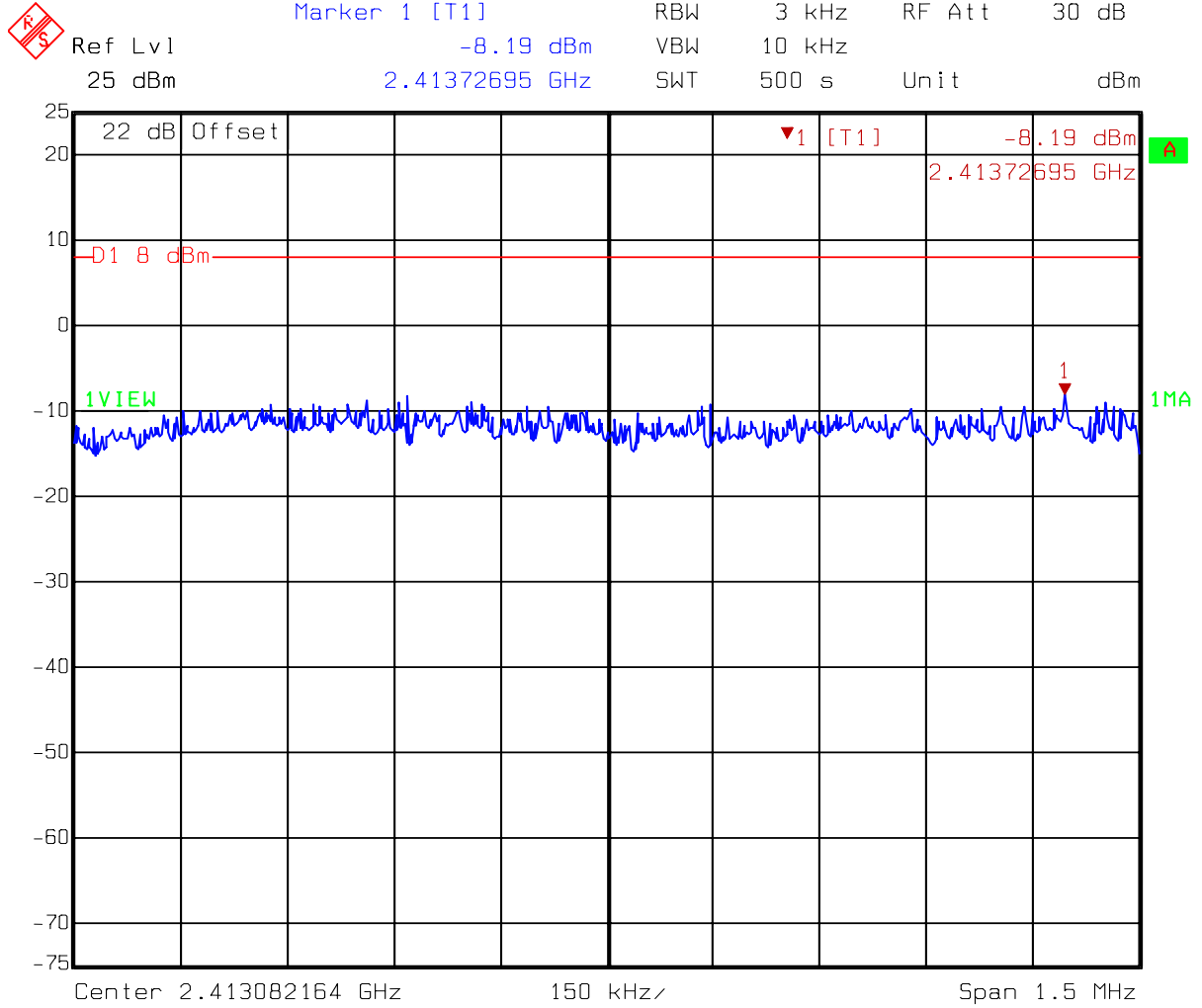

Title: Power density
 Comment A: CH 1 at 802.11b mode
 Date: 05.FEB.2007 09:44:18

Test Mode: 802.11b

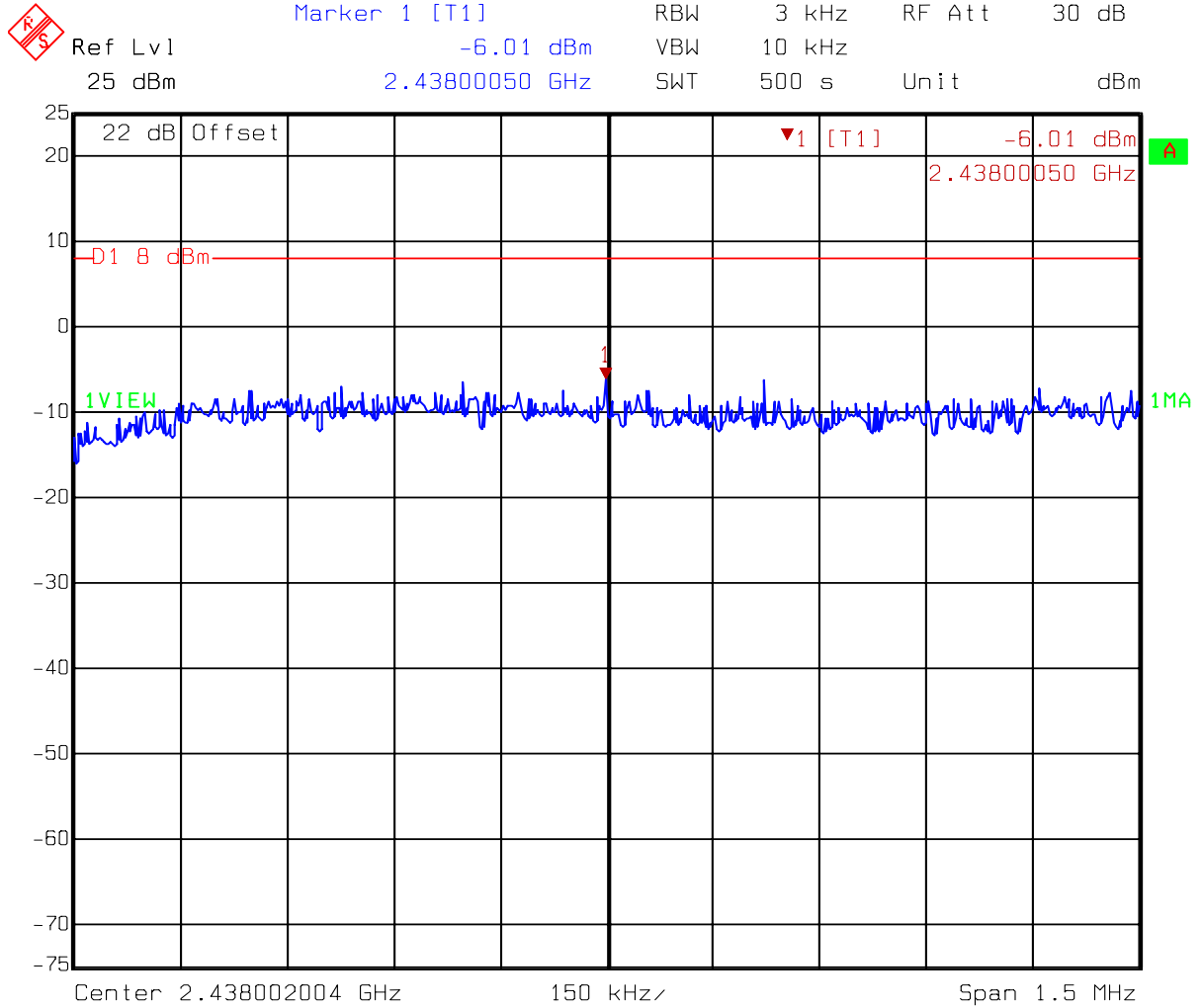

Title: Power density
Comment A: CH 6 at 802.11b mode
Date: 25.JAN.2007 17:35:37

Test Mode: 802.11b

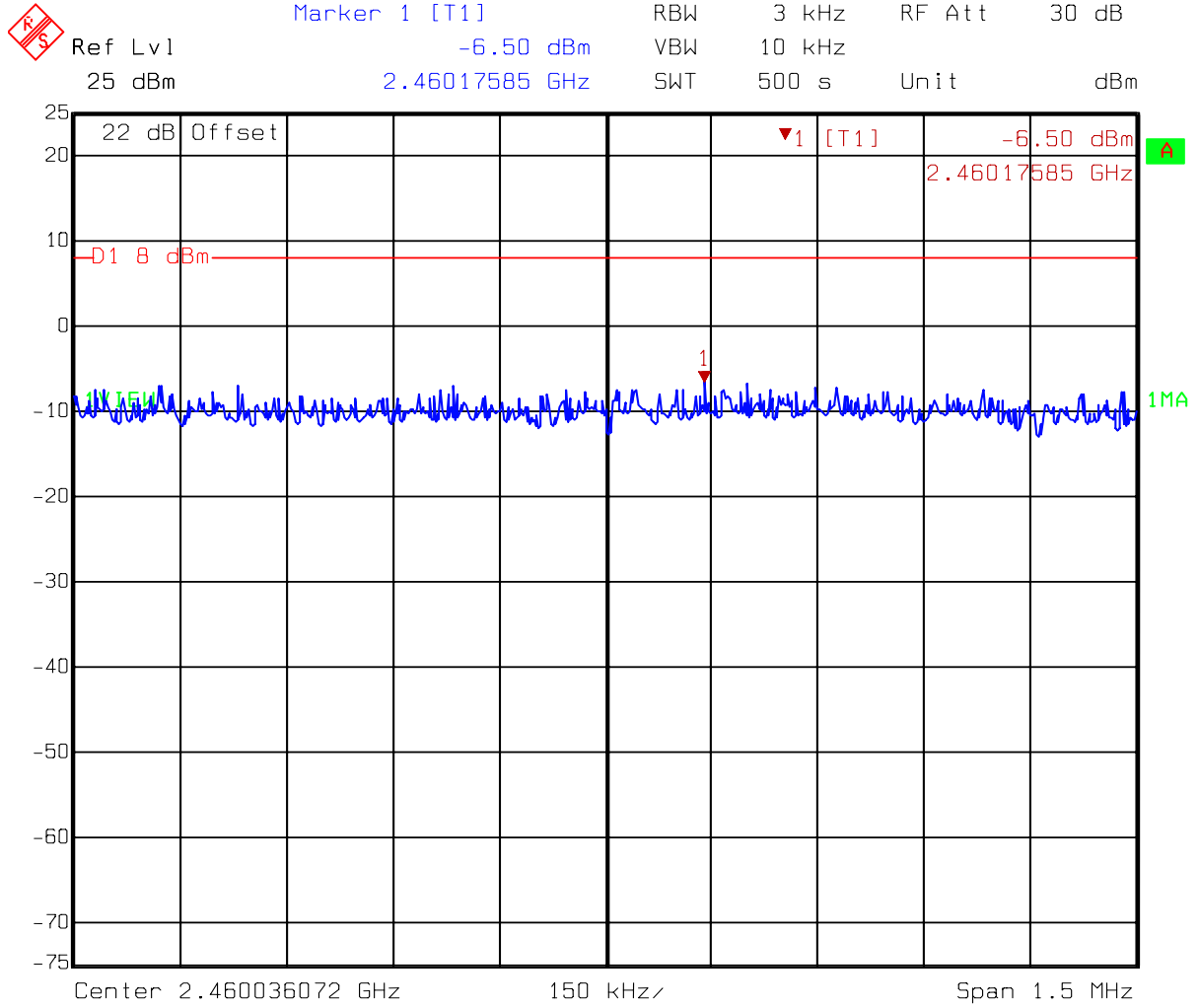

Title: Power density
 Comment A: CH 11 at 802.11b mode
 Date: 25.JAN.2007 17:42:23

Test Mode: 802.11g normal mode

	Ref Lvl	25 dBm	Marker 1 [T1]	-9.77 dBm	RBW	3 kHz	RF Att	30 dB
				2.41352255 GHz	VBW	10 kHz	Unit	dBm
					SWT	500 s		

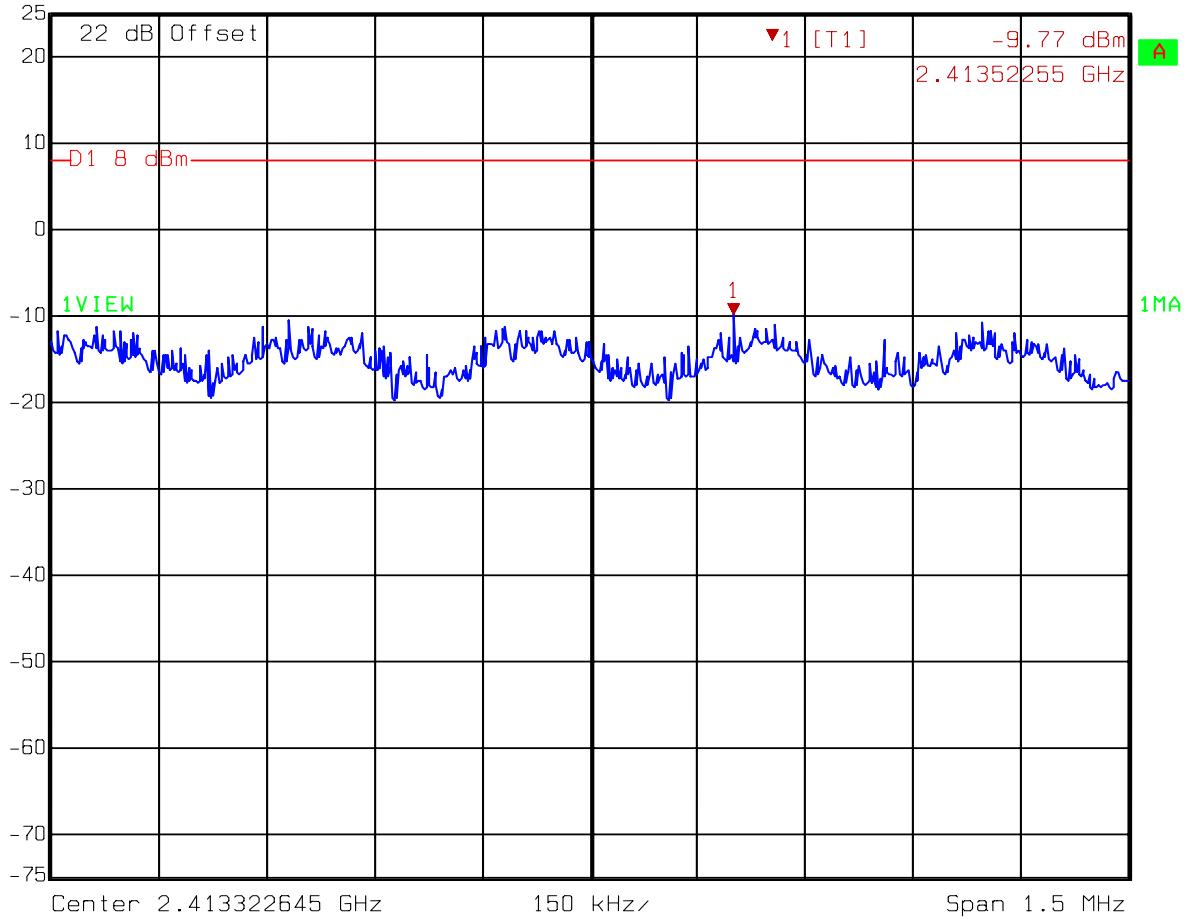

Title: Power density
 Comment A: CH 1 at 802.11g mode
 Date: 05.FEB.2007 09:49:40

Test Mode: 802.11g normal mode

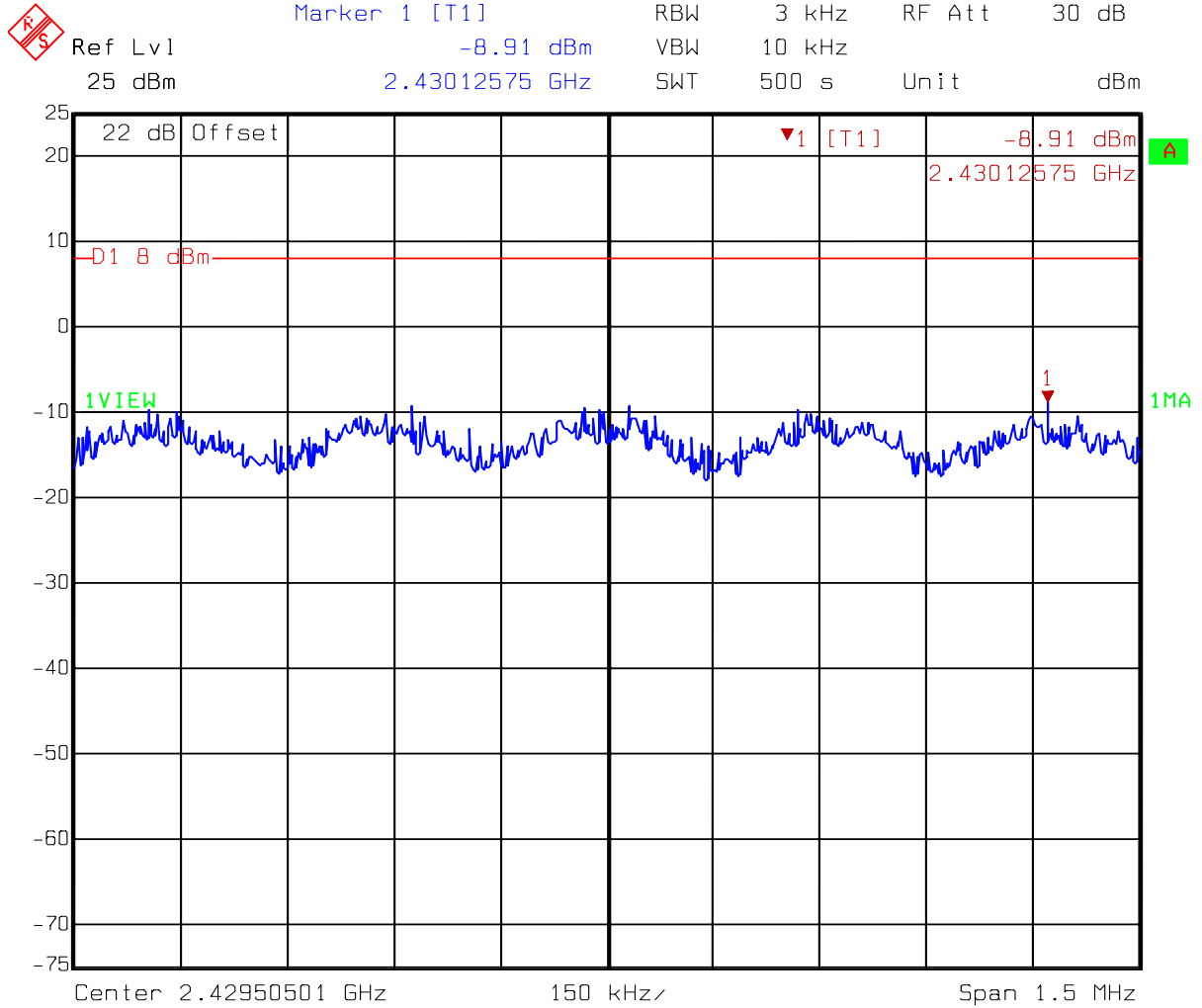

Title: Power density
 Comment A: CH 6 at 802.11g mode
 Date: 25.JAN.2007 17:51:47

Test Mode: 802.11g normal mode

	Ref Lvl	-9.23 dBm	RBW	3 kHz	RF Att	30 dB
	25 dBm	2.45512776 GHz	VBW	10 kHz	SWT	500 s
			Unit			dBm

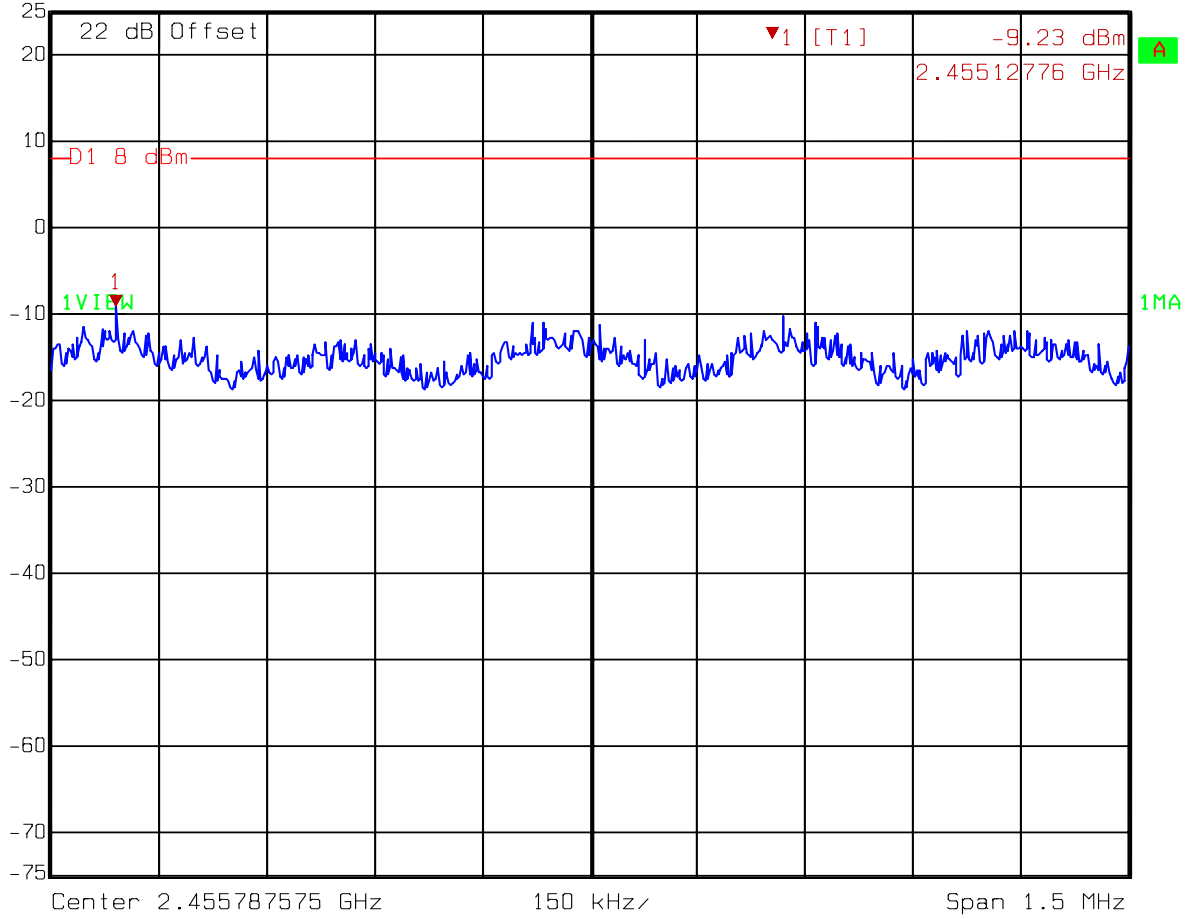

Title: Power density
 Comment A: CH 11 at 802.11g mode
 Date: 05.FEB.2007 12:08:59

Test Mode: 802.11g turbo mode

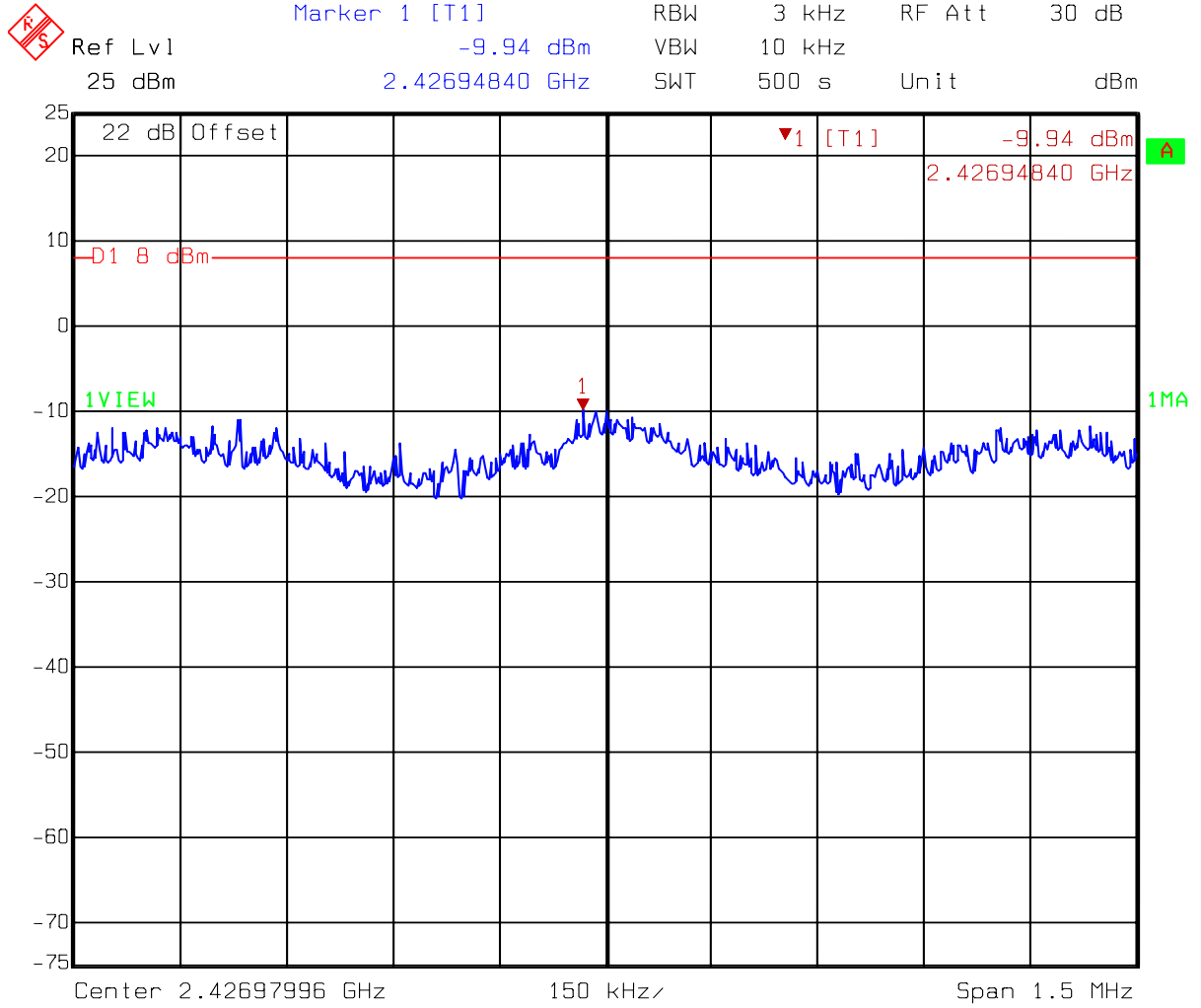

Title: Power density
 Comment A: CH 6 at 802.11g mode (Turbo mode)
 Date: 25.JAN.2007 18:14:09

8. Emission on the band edge

In any 100kHz bandwidth outside the frequency band in which the spread spectrum intentional radiator is operating, the radio frequency power that is produced by the intentional radiator shall be at least 20 dB below that in the 100 KHz bandwidth within the band that contains the highest level of the desired power, based on either an RF conducted or a radiated measurement.

8.1 Operating environment

Temperature:	23	
Relative Humidity:	55	%
Atmospheric Pressure	1023	hPa

8.2 Test setup & procedure

The output of EUT was connected to spectrum analyzer via a 50ohm cable.

The setting of spectrum analyzer is:

Peak:	RBW = 100kHz ;	VBW = 100kHz
Average:	RBW = 1MHz ;	VBW = 10Hz

8.3 Test Result

8.4 Radiated Method

Test Mode: 802.11b

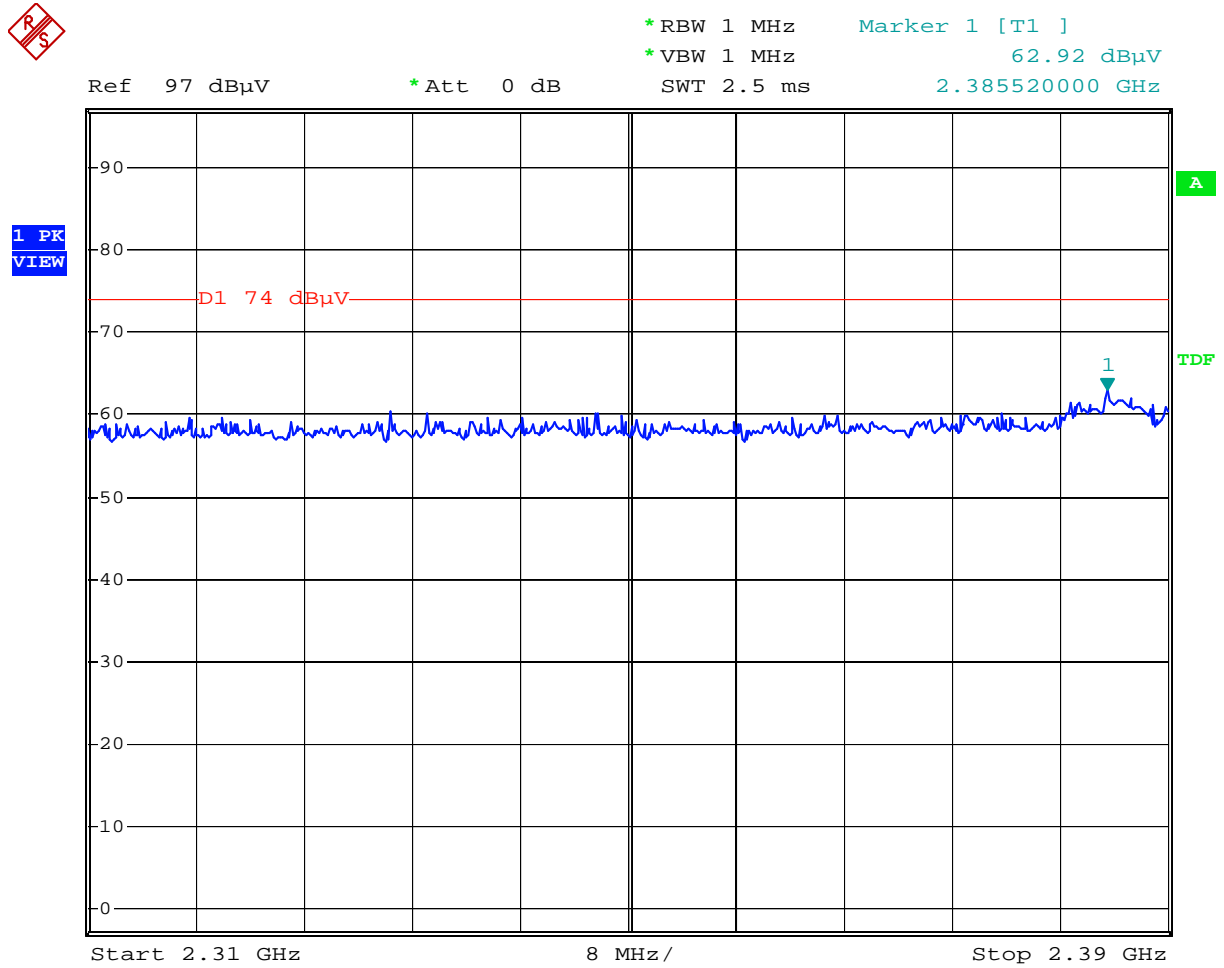

Comment: Band-edge Test at 802.11b Ch1 PK
Date: 5.FEB.2007 09:56:18

Test Mode: 802.11b



*RBW 1 MHz Marker 1 [T1]
*VBW 10 Hz 52.94 dBμV
SWT 20 s 2.386480000 GHz

Ref 97 dBμV

*Att 0 dB

1 AP
VIEW

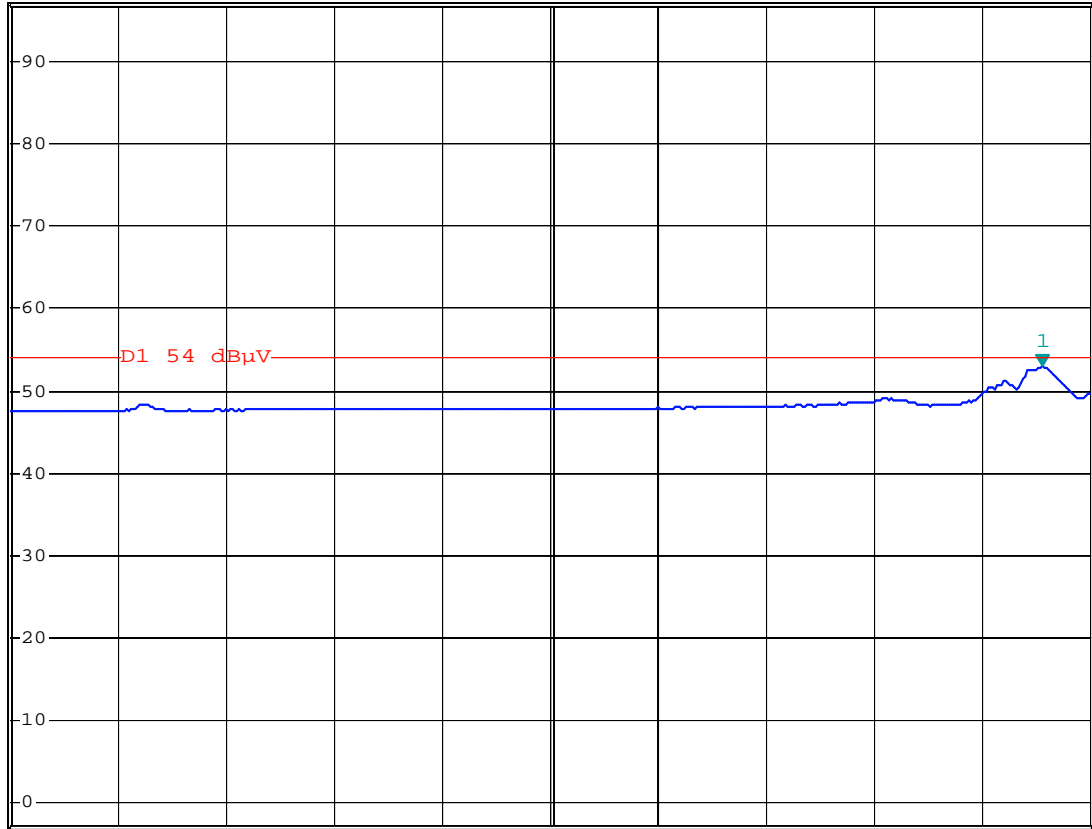

A

TDF

Start 2.31 GHz

8 MHz/

Stop 2.39 GHz

Comment: Band-edge Test at 802.11b Ch1 AV

Date: 5.FEB.2007 09:57:49

Test Mode: 802.11b



*RBW 1 MHz Marker 1 [T1]
*VBW 1 MHz 62.97 dBμV
SWT 2.5 ms 2.487724000 GHz

Ref 97 dBμV

*Att 0 dB

1 PK
VIEW

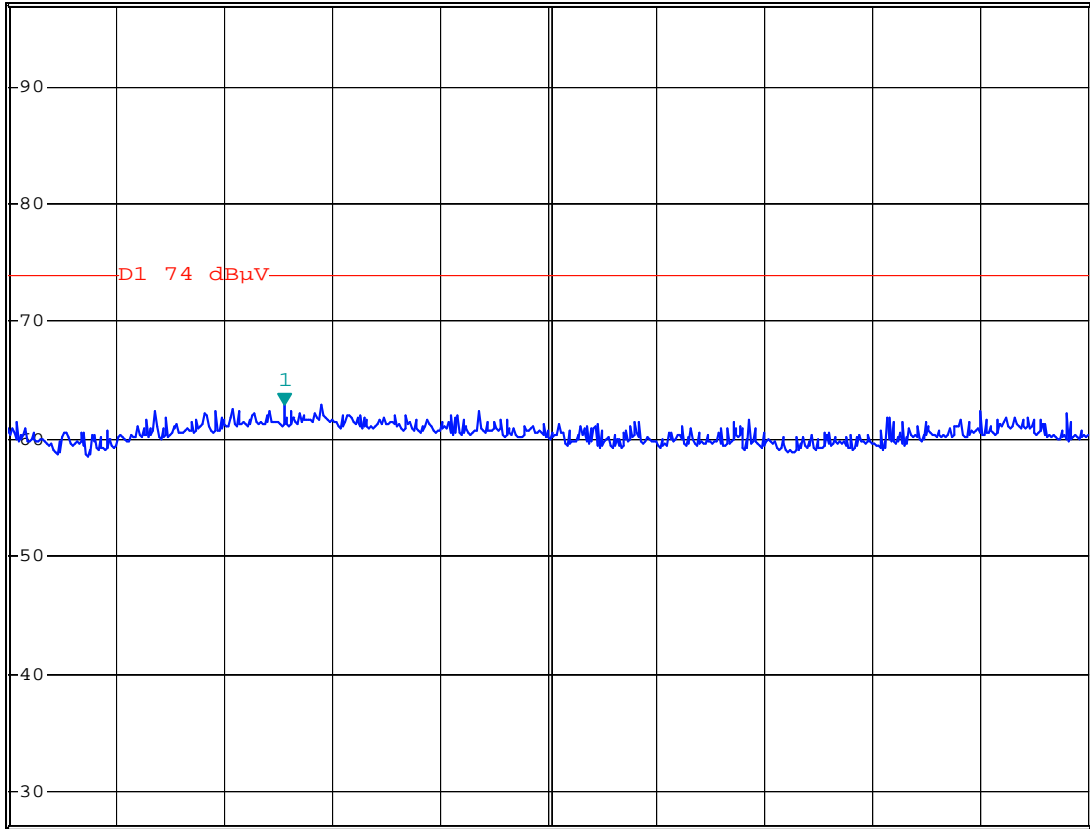

Start 2.4835 GHz

1.65 MHz/

Stop 2.5 GHz

Comment: Band-edge Test at 802.11b Ch11 PK

Date: 29.JAN.2007 17:16:26

Test Mode: 802.11b



*RBW 1 MHz Marker 1 [T1]
*VBW 10 Hz 51.69 dBμV
SWT 4.2 s 2.487724000 GHz

Ref 97 dBμV *Att 0 dB

1 PK*
VIEW

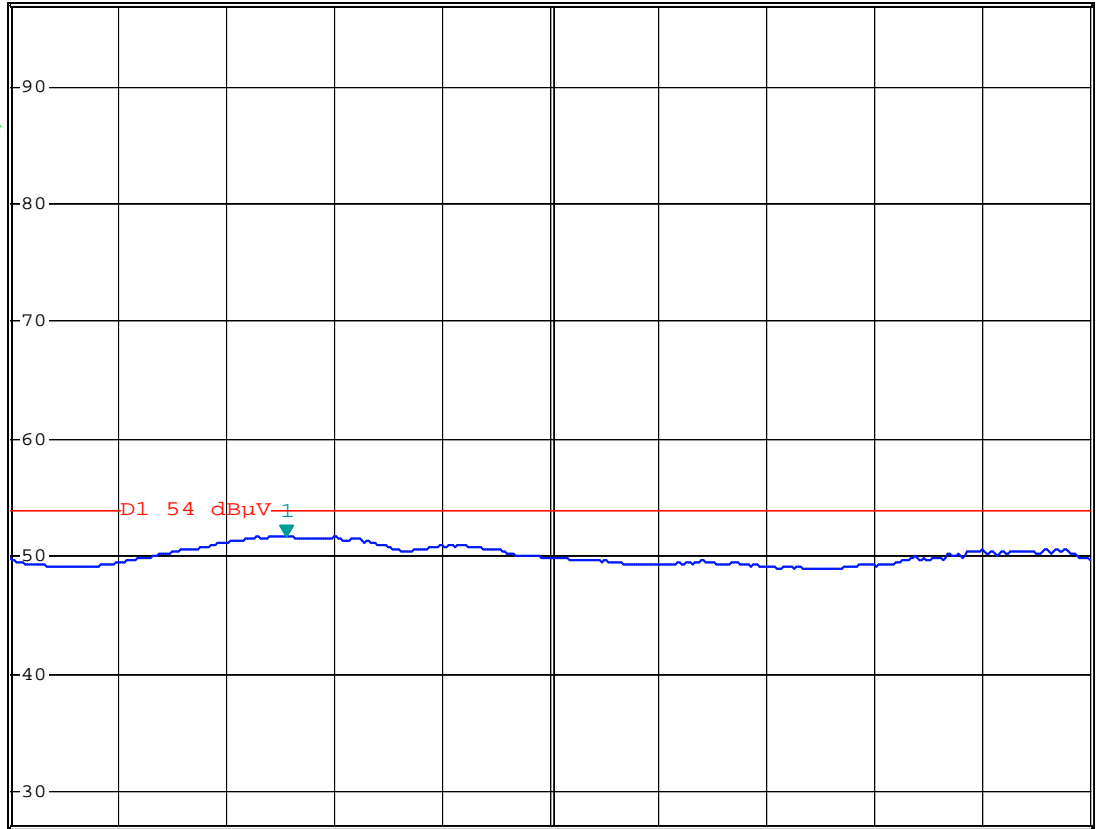

Start 2.4835 GHz 1.65 MHz/ Stop 2.5 GHz

Comment: Band-edge Test at 802.11b Ch11 AV

Date: 29.JAN.2007 17:17:28

Test Mode: 802.11g normal mode



*RBW 1 MHz Marker 1 [T1]
*VBW 1 MHz 68.13 dBμV
SWT 2.5 ms 2.390000000 GHz

Ref 90 dBμV

*Att 0 dB

1 PK
VIEW

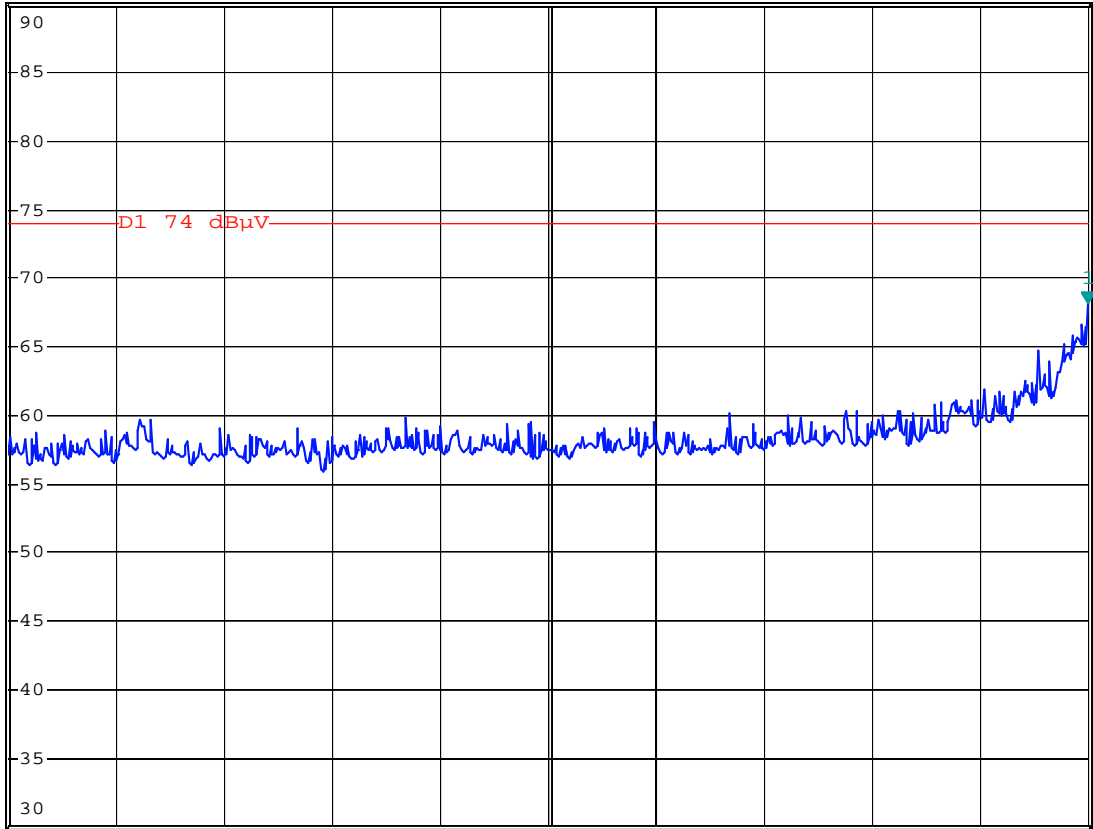

Start 2.31 GHz

8 MHz/

Stop 2.39 GHz

Comment: Band-edge Test at 802.11g Ch1 PK

Date: 29.JAN.2007 17:35:16

Test Mode: 802.11g normal mode



*RBW 1 MHz Marker 1 [T1]
*VBW 10 Hz 52.66 dBμV
SWT 20 s 2.390000000 GHz

Ref 78 dBμV

*Att 0 dB

1 PK*
CLRWR

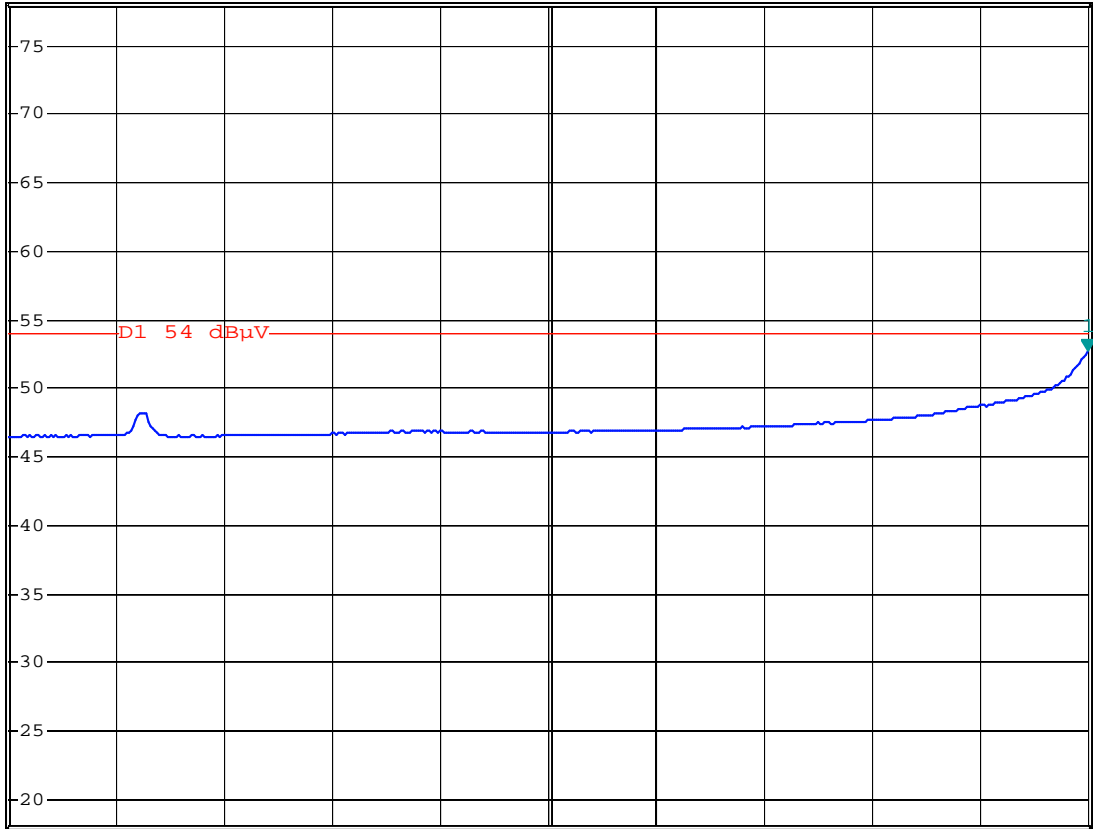

Start 2.31 GHz

8 MHz/

Stop 2.39 GHz

Comment: Band-edge Test at 802.11g Ch1 AV

Date: 29.JAN.2007 17:34:35

Test Mode: 802.11g normal mode



*RBW 1 MHz Marker 1 [T1]
*VBW 1 MHz 73.10 dBμV
SWT 2.5 ms 2.483896000 GHz

Ref 80 dBμV

*Att 0 dB

1 PK
VIEW

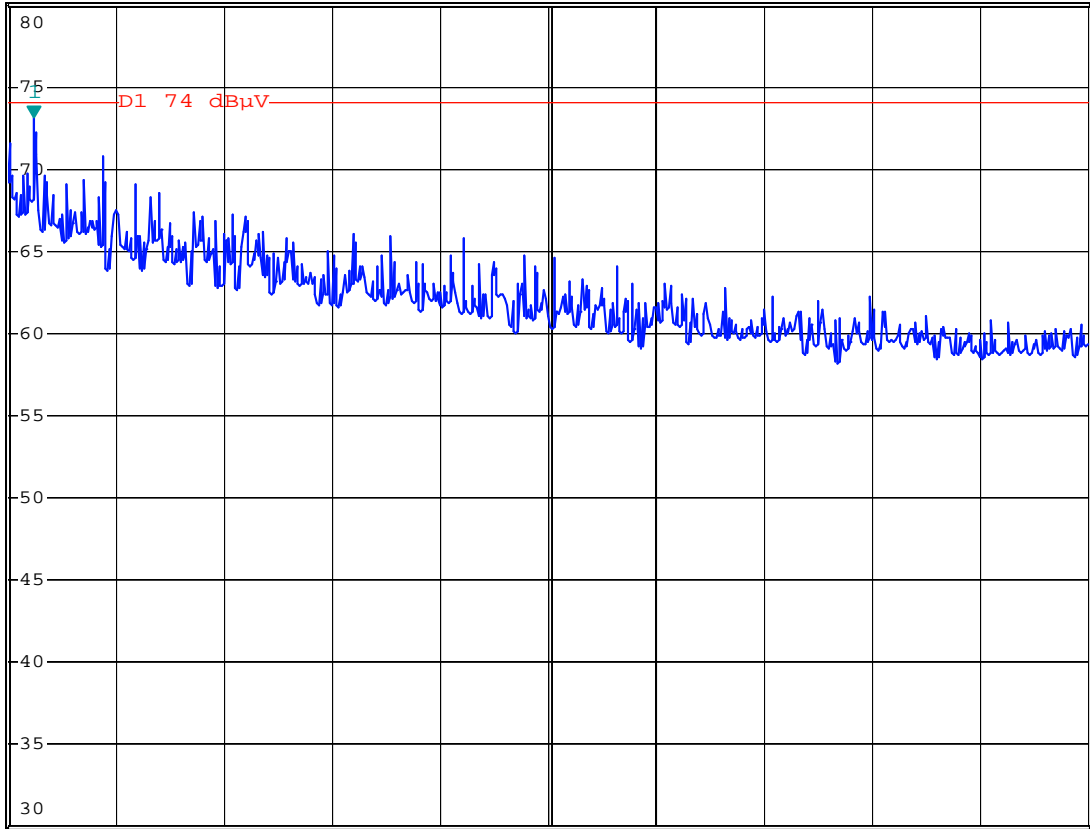

Start 2.4835 GHz

1.65 MHz/

Stop 2.5 GHz

Comment: Band-edge Test at 802.11g Ch11 PK

Date: 29.JAN.2007 17:27:02

Test Mode: 802.11g normal mode



*RBW 1 MHz Marker 1 [T1]
*VBW 10 Hz 52.63 dBμV
SWT 4.2 s 2.483500000 GHz

Ref 80 dBμV

*Att 0 dB

1 PK*
VIEW

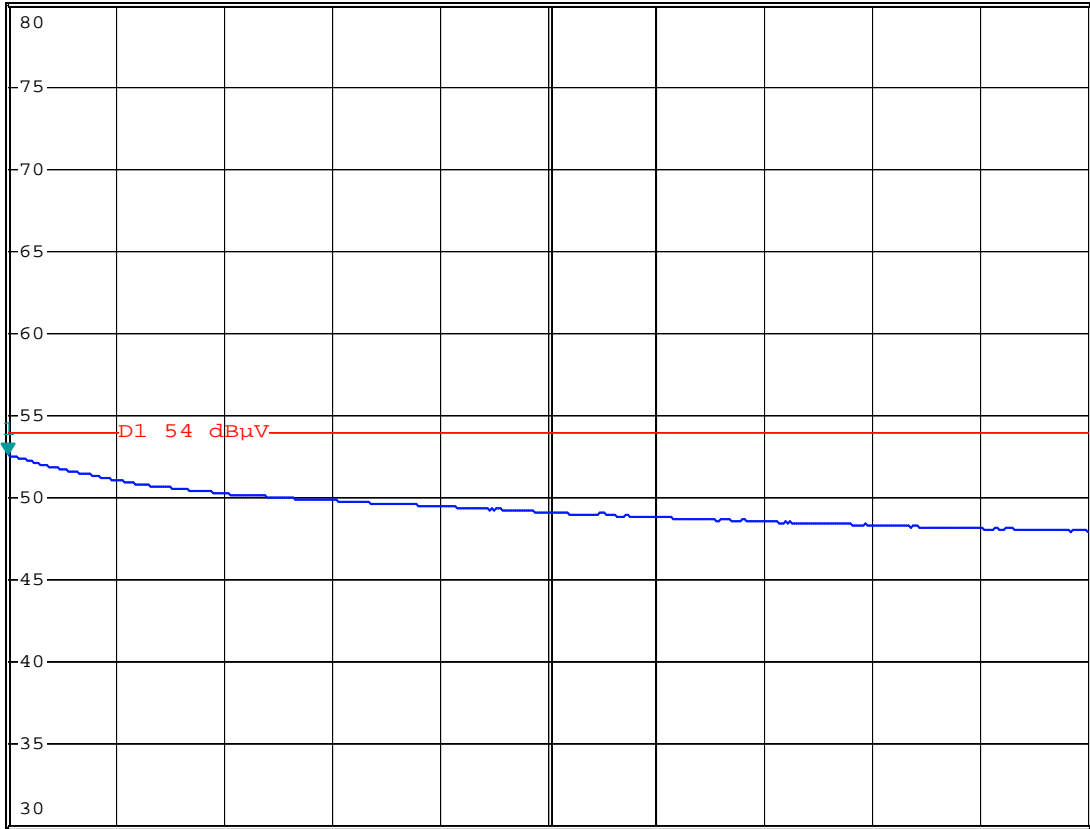

Start 2.4835 GHz

1.65 MHz/

Stop 2.5 GHz

Comment: Band-edge Test at 802.11g Ch11 AV

Date: 29.JAN.2007 17:27:46

9. Power Line Conducted Emission test §FCC 15.207

9.1 Operating environment

Temperature: 23
 Relative Humidity: 53 %
 Atmospheric Pressure 1023 hPa

9.2 Test setup & procedure

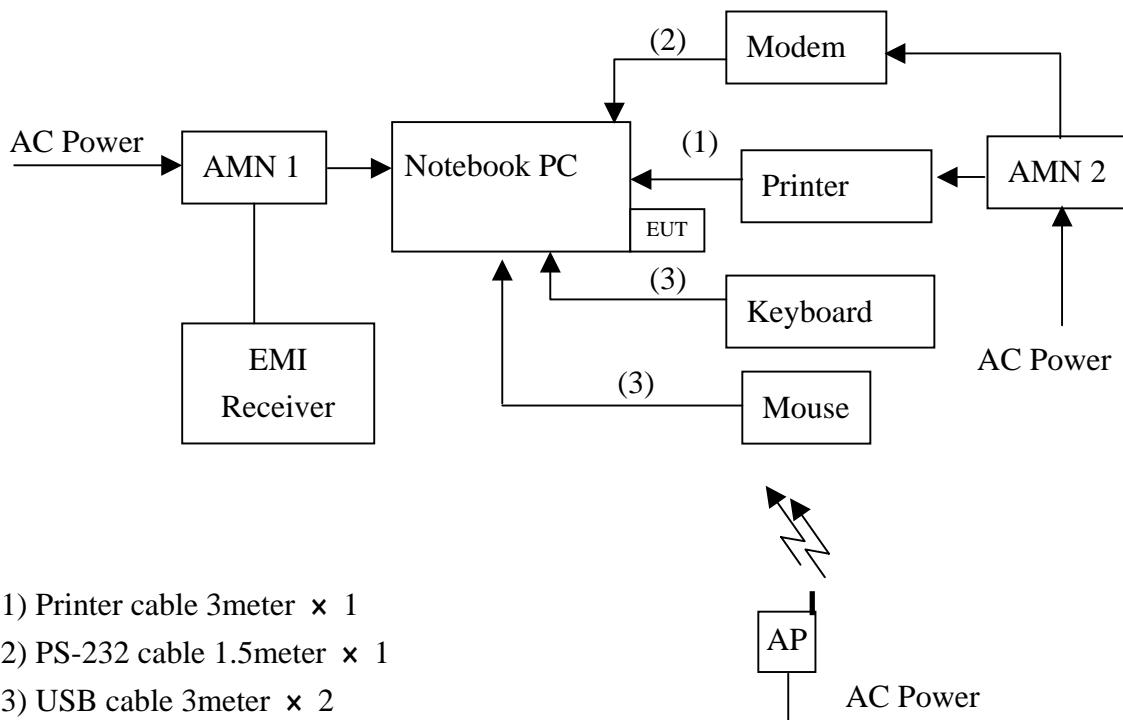

- (1) Printer cable 3meter × 1
- (2) PS-232 cable 1.5meter × 1
- (3) USB cable 3meter × 2

The EUT are connected to the main power through a line impedance stabilization network (LISN). This provides a 50 ohm/50uH coupling impedance for the measuring equipment. The peripheral devices are also connected to the main power through a LISN that provides a 50ohm/50uH coupling impedance with 50ohm termination.

Both sides (Line and Neutral) of AC line are checked for maximum conducted interference. In order to find the maximum emission, the relative positions of equipment and all of the interface cables must be changed according to ANSI C63.4/2003 on conducted measurement. The bandwidth of the field strength meter (R & S Test Receiver ESCS 30) is set at 9kHz.

The EUT configuration please refer to the “Conducted set-up photo.pdf”.

9.3 Emission limit

Freq. (MHz)	Conducted Limit (dBuV)	
	Q.P.	Ave.
0.15~0.50	66 – 56*	56 – 46*
0.50~5.00	56	46
5.00~30.0	60	50

*Decreases with the logarithm of the frequency.

9.4 Uncertainty of Conducted Emission

Expanded uncertainty (k=2) of conducted emission measurement is ± 2.6 dB.

9.5 Power Line Conducted Emission test data

Phase: Line
 Model No.: NWD-670S
 Test Condition: Normal operating mode

Frequency (MHz)	Corr. Factor (dB)	Level Qp (dBuV)	Limit Qp (dBuV)	Level AV (dBuV)	Limit Av (dBuV)	Margin (dB)	
						Qp	Av
0.175	0.10	57.10	64.74	49.99	54.74	-7.64	-4.75
0.233	0.10	48.71	62.34	41.06	52.34	-13.63	-11.28
0.291	0.10	43.17	60.51	36.59	50.51	-17.34	-13.92
0.349	0.10	38.00	58.98	30.85	48.98	-20.98	-18.13
3.842	0.23	38.55	56.00	25.21	46.00	-17.45	-20.79
4.194	0.25	37.08	56.00	23.29	46.00	-18.92	-22.71

Remark:

1. Corr. Factor (dB) = LISN Factor (dB) + Cable Loss (dB)
2. Margin (dB) = Level (dBuV) – Limit (dBuV)

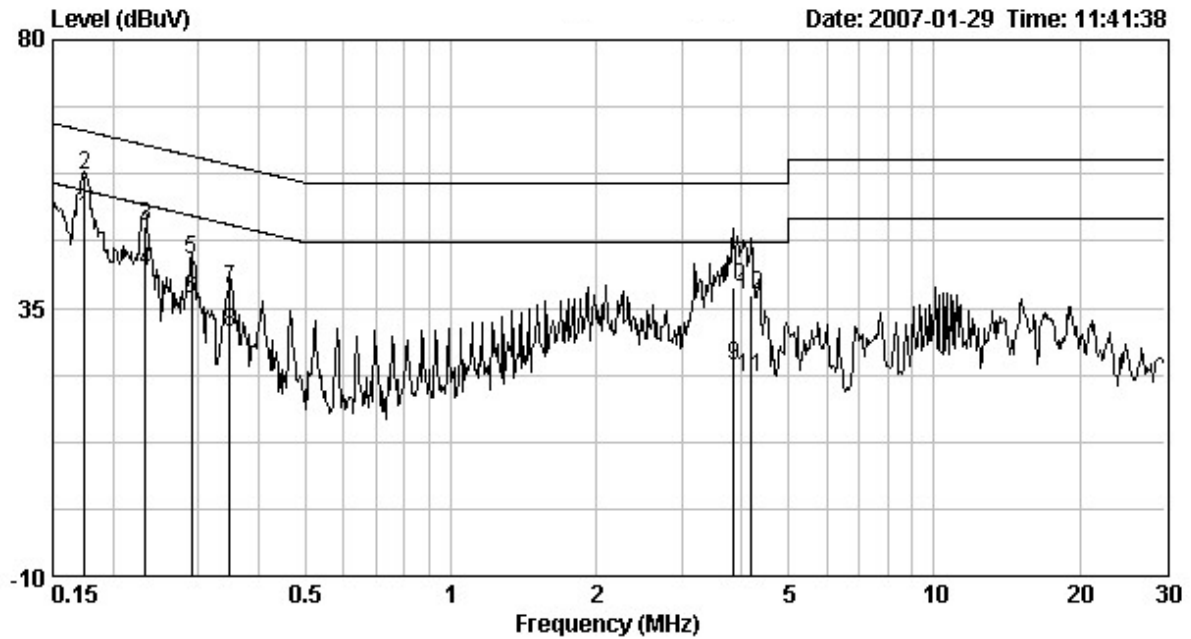

Phase: Neutral
 Model No.: NWD-670S
 Test Condition: Normal operating mode

Frequency (MHz)	Corr. Factor (dB)	Level Qp (dBuV)	Limit Qp (dBuV)	Level AV (dBuV)	Limit Av (dBuV)	Margin (dB)	
						Qp	Av
0.173	0.10	55.37	64.81	48.46	54.81	-9.44	-6.35
0.231	0.10	46.55	62.43	38.85	52.43	-15.88	-13.58
0.288	0.10	41.92	60.57	35.96	50.57	-18.65	-14.61
0.346	0.10	35.92	59.05	30.80	49.05	-23.13	-18.25
3.073	0.18	30.95	56.00	19.03	46.00	-25.05	-26.97
3.935	0.23	37.04	56.00	23.68	46.00	-18.96	-22.32

Remark:

1. Corr. Factor (dB) = LISN Factor (dB) + Cable Loss (dB)
2. Margin (dB) = Level (dBuV) – Limit (dBuV)

