

User's Guide

NWA/WAC Series

802.11 a/b/g/n/ac Unified Access Point

Default Login Details

LAN IP Address	DHCP-assigned OR http://192.168.1.2
User Name	admin
Password	1234

Version 5.10 Edition 1, 11/2017

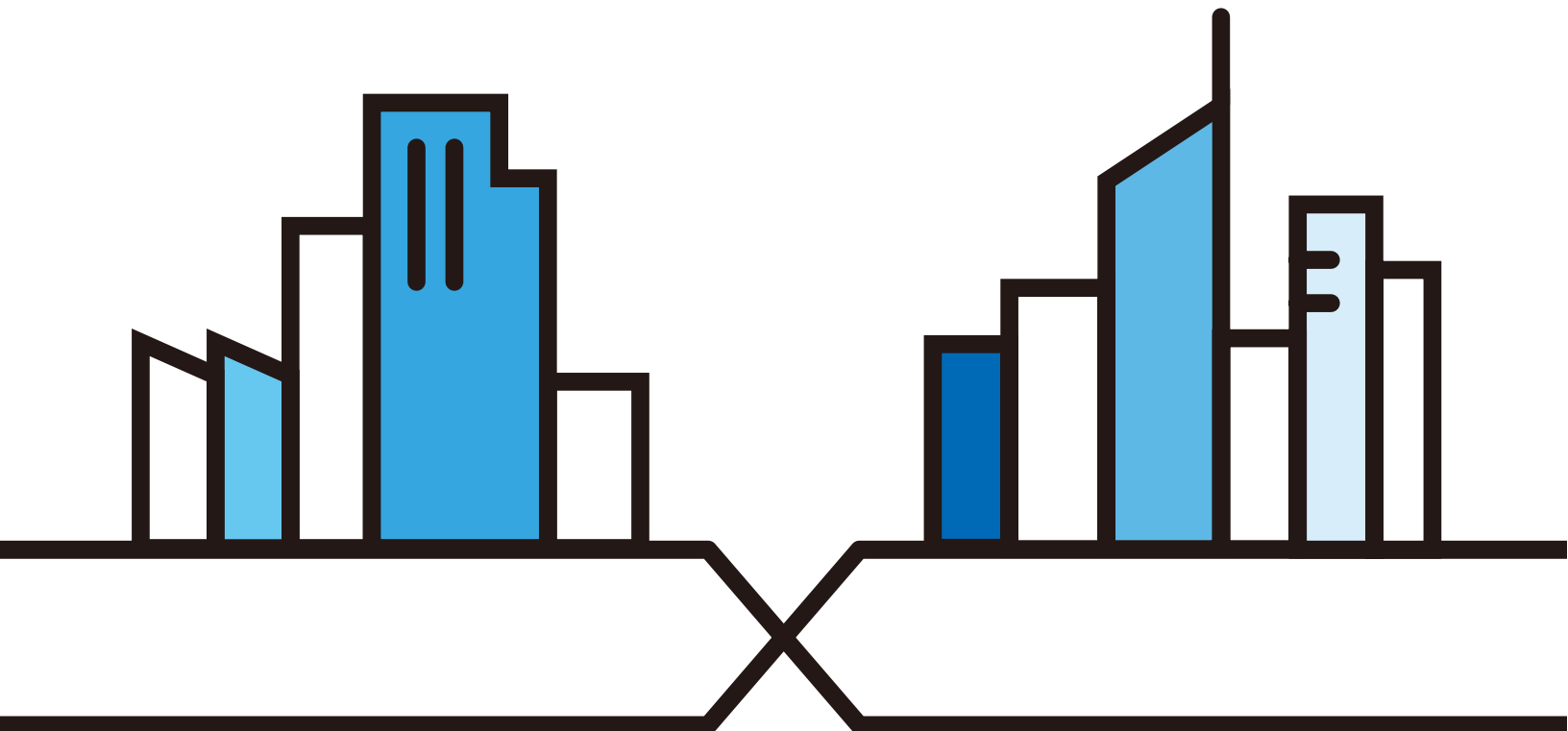

IMPORTANT!

READ CAREFULLY BEFORE USE.

KEEP THIS GUIDE FOR FUTURE REFERENCE.

This is a User's Guide for a series of products. Not all products support all firmware features. Screenshots and graphics in this book may differ slightly from your product due to differences in your product firmware or your computer operating system. Every effort has been made to ensure that the information in this manual is accurate.

Related Documentation

- Quick Start Guide

The Quick Start Guide shows how to connect the NWA/WAC and access the Web Configurator.

- CLI Reference Guide

The CLI Reference Guide explains how to use the Command-Line Interface (CLI) and CLI commands to configure the NWA/WAC.

Note: It is recommended you use the Web Configurator to configure the NWA/WAC.

- Web Configurator Online Help

Click the help icon in any screen for help in configuring that screen and supplementary information.

- More Information

Go to support.zyxel.com to find other information on the NWA/WAC.



Document Conventions

Warnings and Notes

These are how warnings and notes are shown in this guide.

Warnings tell you about things that could harm you or your device.









Note: Notes tell you other important information (for example, other things you may need to configure or helpful tips) or recommendations.

Syntax Conventions

- All models in this series may be referred to as the “NWA/WAC” in this guide.
- Product labels, screen names, field labels and field choices are all in **bold** font.
- A right angle bracket (>) within a screen name denotes a mouse click. For example, **Configuration > Network > IP Setting** means you first click **Configuration** in the navigation panel, then the **Network** sub menu and finally the **IP Setting** tab to get to that screen.

Icons Used in Figures

Figures in this guide may use the following generic icons. The NWA/WAC icon is not an exact representation of your device.

NWA/WAC 	Router 	Switch 	Internet 
Server 	Desktop 	Laptop 	AP Controller 

Contents Overview

User's Guide	12
Introduction	13
The Web Configurator	35
Setup Wizard	47
Technical Reference	53
Dashboard	54
Monitor	60
Network	75
Wireless	84
Bluetooth	97
User	100
AP Profile	107
MON Profile	126
WDS Profile	130
Certificates	132
System	148
Log and Report	173
File Manager	185
Diagnostics	196
LEDs	198
Antenna Switch	200
Reboot	202
Shutdown	203
Troubleshooting	204

Table of Contents

Document Conventions	3
Contents Overview	4
Table of Contents	5
Part I: User's Guide	12
Chapter 1	
Introduction	13
1.1 Overview	13
1.1.1 Management Mode	17
1.1.2 MBSSID	18
1.1.3 Dual-Radio	19
1.1.4 Root AP	19
1.1.5 Repeater	20
1.2 Ways to Manage the NWA/WAC	21
1.3 Good Habits for Managing the NWA/WAC	22
1.4 Hardware Connections	22
1.5 NWA5301-NJ Hardware	22
1.5.1 110 Punch-Down Block	22
1.5.2 Phone Port	24
1.5.3 Console Port	24
1.6 LEDs	25
1.6.1 WAC6502D-E, WAC6502D-S, and WAC6503D-S	25
1.6.2 NWA1123-AC PRO and WAC6103D-I	27
1.6.3 NWA5301-NJ	29
1.6.4 NWA1123-ACv2, NWA5121-N, NWA5121-NI, NWA5123-AC and NWA5123-NI	30
1.6.5 WAC5302D-S	31
1.6.6 NWA1123-AC HD, NWA5123-AC HD and WAC6303D-S	32
1.7 Starting and Stopping the NWA/WAC	33
Chapter 2	
The Web Configurator	35
2.1 Overview	35
2.2 Accessing the Web Configurator	35
2.3 Navigating the Web Configurator	36
2.3.1 Title Bar	37

2.3.2 Navigation Panel	40
2.3.3 Warning Messages	43
2.3.4 Tables and Lists	43
Chapter 3	
Setup Wizard.....	47
3.1 Accessing the Wizard	47
3.2 Using the Wizard	47
3.2.1 Country Code	47
3.2.2 Time Zone	48
3.2.3 Uplink	48
3.2.4 Radio	49
3.2.5 SSID	50
3.2.6 Summary	52
Part II: Technical Reference.....	53
Chapter 4	
Dashboard.....	54
4.1 Overview	54
4.1.1 What You Can Do in this Chapter	54
4.2 Dashboard	54
4.2.1 CPU Usage	58
4.2.2 Memory Usage	59
Chapter 5	
Monitor.....	60
5.1 Overview	60
5.1.1 What You Can Do in this Chapter	60
5.2 What You Need to Know	60
5.3 Network Status	61
5.3.1 Port Statistics Graph	63
5.4 Radio List	64
5.4.1 AP Mode Radio Information	65
5.5 Station List	67
5.6 WDS Link Info	68
5.7 Detected Device	69
5.8 View Log	72
Chapter 6	
Network.....	75

6.1 Overview	75
6.1.1 Management Mode	75
6.1.2 What You Can Do in this Chapter	77
6.2 IP Setting	78
6.3 VLAN	79
6.4 AC (AP Controller) Discovery	82
Chapter 7	
Wireless	84
7.1 Overview	84
7.1.1 What You Can Do in this Chapter	84
7.1.2 What You Need to Know	85
7.2 AP Management	85
7.3 Rogue AP	88
7.3.1 Add/Edit Rogue/Friendly List	90
7.4 Load Balancing	91
7.4.1 Disassociating and Delaying Connections	93
7.5 DCS	94
7.6 Technical Reference	94
Chapter 8	
Bluetooth.....	97
8.1 Overview	97
8.1.1 What You Need To Know	97
8.2 Bluetooth Advertising Settings	97
8.2.1 Edit Advertising Settings	98
Chapter 9	
User.....	100
9.1 Overview	100
9.1.1 What You Can Do in this Chapter	100
9.1.2 What You Need To Know	100
9.2 User Summary	101
9.2.1 Add/Edit User	101
9.3 Setting	103
9.3.1 Edit User Authentication Timeout Settings	105
Chapter 10	
AP Profile.....	107
10.1 Overview	107
10.1.1 What You Can Do in this Chapter	107
10.1.2 What You Need To Know	107
10.2 Radio	108

10.2.1 Add/Edit Radio Profile	109
10.3 SSID	114
10.3.1 SSID List	114
10.3.2 Add/Edit SSID Profile	115
10.4 Security List	118
10.4.1 Add/Edit Security Profile	118
10.5 MAC Filter List	121
10.5.1 Add/Edit MAC Filter Profile	122
10.6 Layer-2 Isolation List	123
10.6.1 Add/Edit Layer-2 Isolation Profile	124
Chapter 11	
MON Profile.....	126
11.1 Overview	126
11.1.1 What You Can Do in this Chapter	126
11.2 MON Profile	126
11.2.1 Add/Edit MON Profile	127
11.3 Technical Reference	128
Chapter 12	
WDS Profile.....	130
12.1 Overview	130
12.1.1 What You Can Do in this Chapter	130
12.2 WDS Profile	130
12.2.1 Add/Edit WDS Profile	131
Chapter 13	
Certificates	132
13.1 Overview	132
13.1.1 What You Can Do in this Chapter	132
13.1.2 What You Need to Know	132
13.1.3 Verifying a Certificate	134
13.2 My Certificates	135
13.2.1 Add My Certificates	136
13.2.2 Edit My Certificates	138
13.2.3 Import Certificates	141
13.3 Trusted Certificates	142
13.3.1 Edit Trusted Certificates	143
13.3.2 Import Trusted Certificates	146
13.4 Technical Reference	147
Chapter 14	
System.....	148

14.1 Overview	148
14.1.1 What You Can Do in this Chapter	148
14.2 Host Name	148
14.3 Date and Time	149
14.3.1 Pre-defined NTP Time Servers List	152
14.3.2 Time Server Synchronization	152
14.4 WWW Overview	153
14.4.1 Service Access Limitations	153
14.4.2 System Timeout	153
14.4.3 HTTPS	154
14.4.4 Configuring WWW Service Control	154
14.4.5 HTTPS Example	155
14.5 SSH	163
14.5.1 How SSH Works	163
14.5.2 SSH Implementation on the NWA/WAC	164
14.5.3 Requirements for Using SSH	165
14.5.4 Configuring SSH	165
14.5.5 Examples of Secure Telnet Using SSH	165
14.6 Telnet	167
14.7 FTP	167
14.8 SNMP	168
14.8.1 Supported MIBs	169
14.8.2 SNMP Traps	170
14.8.3 Configuring SNMP	170
14.8.4 Adding or Editing an SNMPv3 User Profile	171

Chapter 15

Log and Report.....173

15.1 Overview	173
15.1.1 What You Can Do In this Chapter	173
15.2 Email Daily Report	173
15.3 Log Setting	175
15.3.1 Log Setting Screen	176
15.3.2 Edit System Log Settings	177
15.3.3 Edit Remote Server	181
15.3.4 Active Log Summary	182

Chapter 16

File Manager185

16.1 Overview	185
16.1.1 What You Can Do in this Chapter	185
16.1.2 What you Need to Know	185
16.2 Configuration File	186

16.2.1 Example of Configuration File Download Using FTP	190
16.3 Firmware Package	191
16.3.1 Example of Firmware Upload Using FTP	192
16.4 Shell Script	193
Chapter 17	
Diagnostics	196
17.1 Overview	196
17.1.1 What You Can Do in this Chapter	196
17.2 Diagnostics	196
Chapter 18	
LEDs	198
18.1 Overview	198
18.1.1 What You Can Do in this Chapter	198
18.2 Suppression Screen	198
18.3 Locator Screen	199
Chapter 19	
Antenna Switch	200
19.1 Overview	200
19.1.1 What You Need To Know	200
19.2 Antenna Switch Screen	200
Chapter 20	
Reboot.....	202
20.1 Overview	202
20.1.1 What You Need To Know	202
20.2 Reboot	202
Chapter 21	
Shutdown	203
21.1 Overview	203
21.1.1 What You Need To Know	203
21.2 Shutdown	203
Chapter 22	
Troubleshooting.....	204
22.1 Overview	204
22.2 Power, Hardware Connections, and LED	204
22.3 NWA/WAC Access and Login	205
22.4 Internet Access	206
22.5 Wireless Connections	207

22.6 Resetting the NWA/WAC	212
22.7 Getting More Troubleshooting Help	213
Appendix A Importing Certificates	214
Appendix B IPv6.....	227
Appendix C Customer Support	235
Appendix D Legal Information	241
Index	254

PART I

User's Guide

CHAPTER 1

Introduction

1.1 Overview

This User's Guide covers the following models: NWA1123-ACv2, NWA1123-AC PRO, NWA1123-AC HD, NWA5121-N, NWA5121-NI, NWA5123-AC, NWA5123-AC HD, NWA5123-NI, NWA5301-NJ, WAC5302D-S, WAC6103D-I, WAC6303D-S, WAC6502D-E, WAC6502D-S, WAC6503D-S, and WAC6553D-E. Your NWA/WAC is a wireless AP (Access Point). It extends the range of your existing wired network without additional wiring, providing easy network access to mobile users.

Table 1 NWA1123 Series Comparison Table

FEATURES	NWA1123-ACv2	NWA1123-AC PRO	NWA1123-AC HD
Supported Wireless Standards	IEEE 802.11a IEEE 802.11b IEEE 802.11g IEEE 802.11n IEEE 802.11ac	IEEE 802.11a IEEE 802.11b IEEE 802.11g IEEE 802.11n IEEE 802.11ac	IEEE 802.11a IEEE 802.11b IEEE 802.11g IEEE 802.11n IEEE 802.11ac
Supported Frequency Bands	2.4 GHz 5 GHz	2.4 GHz 5 GHz	2.4 GHz 5 GHz
Available Security Modes	None WEP WPA2 WPA2-MIX WPA2-PSK WPA2-PSK-MIX	None WEP WPA2 WPA2-MIX WPA2-PSK WPA2-PSK-MIX	None WEP WPA2 WPA2-MIX WPA2-PSK WPA2-PSK-MIX
Number of SSID Profiles	64	64	64
Number of Wireless Radios	2	2	2
Monitor Mode & Rogue APs Containment	Yes	Yes	No
Rogue APs Detection	Yes	Yes	Yes
WDS (Wireless Distribution System) - Root AP & Repeater Modes	Yes	Yes	No
Tunnel Forwarding Mode	No	No	No
Layer-2 Isolation	Yes	Yes	Yes
Power Detection	No	No	No
External Antennas	No	No	No
Internal Antennas	Yes	Yes	Yes
Antenna Switch	No	Yes	No
LED Locator	No	Yes	Yes

Table 1 NWA1123 Series Comparison Table

FEATURES	NWA1123-ACv2	NWA1123-AC PRO	NWA1123-AC HD
CAPWAP Managed AP Mode	No	No	No
AC (AP Controller) Discovery	No	No	No
802.11r Fast Roaming Support in Managed AP Mode	No	No	No
Bluetooth Low Energy (BLE)	No	No	No
Maximum number of log messages	512 event logs or 1024 debug logs		

Table 2 NWA5000 Series Comparison Table

FEATURES	NWA5121-N	NWA5121-NI	NWA5123-AC	NWA5123-AC HD	NWA5123-NI	NWA5301-NJ
Supported Wireless Standards	IEEE 802.11b IEEE 802.11g IEEE 802.11n	IEEE 802.11b IEEE 802.11g IEEE 802.11n	IEEE 802.11a IEEE 802.11b IEEE 802.11g IEEE 802.11n IEEE 802.11ac	IEEE 802.11a IEEE 802.11b IEEE 802.11g IEEE 802.11n IEEE 802.11ac	IEEE 802.11a IEEE 802.11b IEEE 802.11g IEEE 802.11n	IEEE 802.11b IEEE 802.11g IEEE 802.11n
Supported Frequency Bands	2.4 GHz	2.4 GHz	2.4 GHz 5 GHz	2.4 GHz 5 GHz	2.4 GHz 5 GHz	2.4 GHz
Available Security Modes	None WEP WPA2 WPA2-MIX WPA2-PSK WPA2-PSK-MIX	None WEP WPA2 WPA2-MIX WPA2-PSK WPA2-PSK-MIX	None WEP WPA2 WPA2-MIX WPA2-PSK WPA2-PSK-MIX	None WEP WPA2 WPA2-MIX WPA2-PSK WPA2-PSK-MIX	None WEP WPA2 WPA2-MIX WPA2-PSK WPA2-PSK-MIX	None WEP WPA2 WPA2-MIX WPA2-PSK WPA2-PSK-MIX
Number of SSID Profiles	64	64	64	64	64	64
Number of Wireless Radios	1	1	2	2	2	1
Monitor Mode & Rogue APs Containment	Yes	Yes	Yes	No	Yes	No
Rogue APs Detection	Yes	Yes	Yes	Yes	Yes	Yes
WDS (Wireless Distribution System) - Root AP & Repeater Modes	Yes	Yes	Yes	No	Yes	Yes
Tunnel Forwarding Mode	No	No	No	No	No	No
Layer-2 Isolation	Yes	Yes	Yes	Yes	Yes	Yes
Power Detection	No	No	No	No	No	No
External Antennas	Yes	No	No	No	No	No
Internal Antennas	No	Yes	Yes	Yes	Yes	Yes
Antenna Switch	No	No	No	No	No	No
LED Locator	No	No	No	Yes	No	No
CAPWAP Managed AP Mode	Yes	Yes	Yes	Yes	Yes	Yes

Table 2 NWA5000 Series Comparison Table

FEATURES	NWA5121-N	NWA5121-NI	NWA5123-AC	NWA5123-AC HD	NWA5123-NI	NWA5301-NJ
AC (AP Controller) Discovery	Yes	Yes	Yes	Yes	Yes	Yes
802.11r Fast Roaming Support in Managed AP Mode	Yes	Yes	Yes	No	Yes	Yes
Bluetooth Low Energy (BLE)	No	No	No	No	No	No
Maximum number of log messages	256 event logs or 1 debug logs	256 event logs or 1 debug logs	512 event logs or 1024 debug logs	512 event logs or 1024 debug logs	256 event logs or 1 debug logs	256 event logs or 1 debug logs

Table 3 WAC5000/6000 Series Comparison Table

FEATURES	WAC5302D-S	WAC6103D-I	WAC6303D-S
Supported Wireless Standards	IEEE 802.11a IEEE 802.11b IEEE 802.11g IEEE 802.11n IEEE 802.11ac	IEEE 802.11a IEEE 802.11b IEEE 802.11g IEEE 802.11n IEEE 802.11ac	IEEE 802.11a IEEE 802.11b IEEE 802.11g IEEE 802.11n IEEE 802.11ac
Supported Frequency Bands	2.4 GHz 5 GHz	2.4 GHz 5 GHz	2.4 GHz 5 GHz
Available Security Modes	None WEP WPA2 WPA2-MIX WPA2-PSK WPA2-PSK-MIX	None WEP WPA2 WPA2-MIX WPA2-PSK WPA2-PSK-MIX	None WEP WPA2 WPA2-MIX WPA2-PSK WPA2-PSK-MIX
Number of SSID Profiles	64	64	64
Number of Wireless Radios	2	2	2
Monitor Mode & Rogue APs Containment	No	Yes	No
Rogue APs Detection	Yes	Yes	Yes
WDS (Wireless Distribution System) - Root AP & Repeater Modes	No	Yes	No
Tunnel Forwarding Mode	No	Yes	Yes
Layer-2 Isolation	Yes	Yes	Yes
Power Detection	Yes	No	Yes
External Antennas	No	No	No
Internal Antennas	Yes	Yes	Yes
Antenna Switch	No	Yes	No
LED Locator	No	Yes	Yes
CAPWAP Managed AP Mode	Yes	Yes	Yes
AC (AP Controller) Discovery	Yes	Yes	Yes

Table 3 WAC5000/6000 Series Comparison Table

FEATURES	WAC5302D-S	WAC6103D-I	WAC6303D-S
802.11r Fast Roaming Support in Managed AP Mode	No	Yes	No
Bluetooth Low Energy (BLE)	Yes	No	Yes
Maximum number of log messages	256 event logs or 1 debug logs	512 event logs or 1024 debug logs	512 event logs or 1024 debug logs

Table 4 WAC6500 Series Comparison Table

FEATURES	WAC6502D-E	WAC6502D-S	WAC6503D-S	WAC6553D-E
Supported Wireless Standards	IEEE 802.11a IEEE 802.11b IEEE 802.11g IEEE 802.11n IEEE 802.11ac	IEEE 802.11a IEEE 802.11b IEEE 802.11g IEEE 802.11n IEEE 802.11ac	IEEE 802.11a IEEE 802.11b IEEE 802.11g IEEE 802.11n IEEE 802.11ac	IEEE 802.11a IEEE 802.11b IEEE 802.11g IEEE 802.11n IEEE 802.11ac
Supported Frequency Bands	2.4 GHz 5 GHz	2.4 GHz 5 GHz	2.4 GHz 5 GHz	2.4 GHz 5 GHz
Available Security Modes	None WEP WPA2 WPA2-MIX WPA2-PSK WPA2-PSK-MIX	None WEP WPA2 WPA2-MIX WPA2-PSK WPA2-PSK-MIX	None WEP WPA2 WPA2-MIX WPA2-PSK WPA2-PSK-MIX	None WEP WPA2 WPA2-MIX WPA2-PSK WPA2-PSK-MIX
Number of SSID Profiles	64	64	64	64
Number of Wireless Radios	2	2	2	2
Monitor Mode & Rogue APs Containment	Yes	Yes	Yes	Yes
Rogue APs Detection	Yes	Yes	Yes	Yes
WDS (Wireless Distribution System) - Root AP & Repeater Modes	Yes	Yes	Yes	Yes
Tunnel Forwarding Mode	Yes	Yes	Yes	Yes
Layer-2 Isolation	Yes	Yes	Yes	Yes
Power Detection	Yes	Yes	Yes	Yes
External Antennas	Yes	No	No	Yes
Internal Antennas	No	Yes	Yes	No
Antenna Switch	No	No	No	No
LED Locator	Yes	Yes	Yes	Yes
CAPWAP Managed AP Mode	Yes	Yes	Yes	Yes
AC (AP Controller) Discovery	Yes	Yes	Yes	Yes
802.11r Fast Roaming Support in Managed AP Mode	Yes	Yes	Yes	Yes

Table 4 WAC6500 Series Comparison Table

FEATURES	WAC6502D-E	WAC6502D-S	WAC6503D-S	WAC6553D-E
Bluetooth Low Energy (BLE)	No	No	No	No
Maximum number of log messages	512 event logs or 1024 debug logs			

You can set the NWA/WAC to operate in either standalone AP or managed AP mode. When the NWA/WAC is in standalone AP mode, it can serve as a normal AP, as an RF monitor to search for rogue APs to help eliminate network threats (if it supports monitor mode and rogue APs detection/containment), or even as a root AP or a wireless repeater to establish wireless links with other APs in a WDS (Wireless Distribution System). A WDS is a wireless connection between two or more APs.

Your NWA/WAC's business-class reliability, SMB features, and centralized wireless management make it ideally suited for advanced service delivery in mission-critical networks. It uses Multiple BSSID and VLAN to provide simultaneous independent virtual APs. Additionally, innovations in roaming technology and QoS features eliminate voice call disruptions.

The NWA/WAC controls network access with Media Access Control (MAC) address filtering, and rogue Access Point (AP) detection. It also provides a high level of network traffic security, supporting IEEE 802.1x, Wi-Fi Protected Access 2 and Wired Equivalent Privacy (WEP) data encryption.

Your NWA/WAC is easy to install, configure and use. The embedded Web-based configurator enables simple, straightforward management and maintenance. See the Quick Start Guide for how to make hardware connections.

1.1.1 Management Mode

The NWA/WAC is a unified AP and can work either in standalone AP mode or in managed AP mode. If the NWA/WAC and a Zyxel AP controller, such as the NXC2500 or NXC5500, are in the same subnet, it will be managed by the controller automatically.

An AP controller uses Control And Provisioning of Wireless Access Points (CAPWAP, see RFC 5415) to discover and configure multiple managed APs.

To set the NWA/WAC to be managed by an AP controller in a different subnet or change between management modes, use the **AC (AP Controller) Discovery** screen (see [Section 6.4 on page 82](#)).

Table 5 NWA/WAC Management Mode Comparison

MANAGEMENT MODE	DEFAULT IP ADDRESS	UPLOAD FIRMWARE VIA
Standalone AP	Dynamic or Static (192.168.1.2)	Web Configurator or FTP
Managed AP	Dynamic	CAPWAP or FTP

When the NWA/WAC is in standalone AP mode and connects to a DHCP server, it uses the IP address assigned by the DHCP server. Otherwise, the NWA/WAC uses the default static management IP address (192.168.1.2). You can use the **AC Discovery** screen to have the NWA/WAC work as a managed AP.

When the NWA/WAC is in managed AP mode, it acts as a DHCP client and obtains an IP address from the AP controller. It can be configured ONLY by the AP controller. To change the NWA/WAC back to standalone AP mode, use the **Reset** button to restore the default configuration. Alternatively, you need to check the AP controller for the NWA/WAC's IP address and use FTP to upload the default configuration file at conf/system-default.conf to the NWA/WAC and reboot the device.

1.1.2 MBSSID

A Basic Service Set (BSS) is the set of devices forming a single wireless network (usually an access point and one or more wireless clients). The Service Set Identifier (SSID) is the name of a BSS. In Multiple BSS (MBSSID) mode, the NWA/WAC provides multiple virtual APs, each forming its own BSS and using its own individual SSID profile.

You can configure multiple SSID profiles, and have all of them active at any one time.

You can assign different wireless and security settings to each SSID profile. This allows you to compartmentalize groups of users, set varying access privileges, and prioritize network traffic to and from certain BSSs.

To the wireless clients in the network, each SSID appears to be a different access point. As in any wireless network, clients can associate only with the SSIDs for which they have the correct security settings.

For example, you might want to set up a wireless network in your office where Internet telephony (VoIP) users have priority. You also want a regular wireless network for standard users, as well as a 'guest' wireless network for visitors. In the following figure, **VoIP_SSID** users have QoS priority, **SSID01** is the wireless network for standard users, and **Guest_SSID** is the wireless network for guest users. In this example, the guest user is forbidden access to the wired Land Area Network (LAN) behind the AP and can access only the Internet.

Figure 1 Multiple BSSs

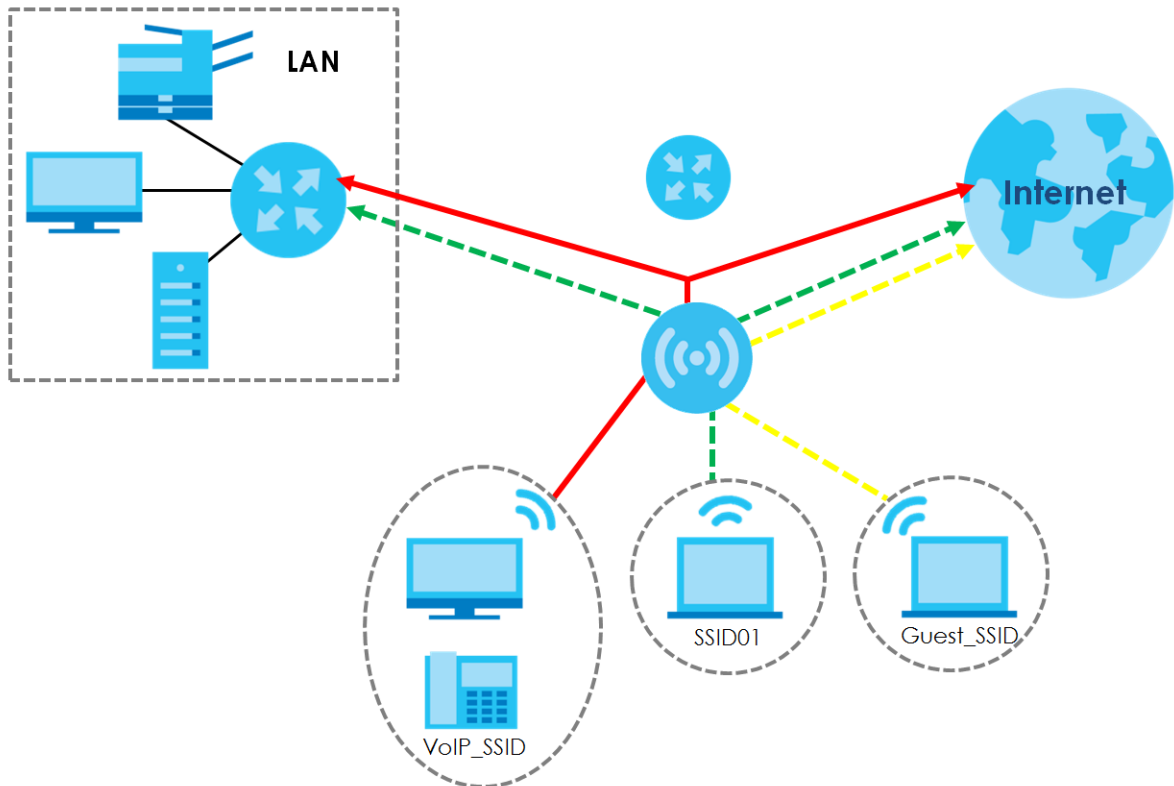

1.1.3 Dual-Radio

Some of the NWA/WAC models are equipped with dual wireless radios. This means you can configure two different wireless networks to operate simultaneously.

Note: A different channel should be configured for each WLAN interface to reduce the effects of radio interference.

You could use the 2.4 GHz band for regular Internet surfing and downloading while using the 5 GHz band for time sensitive traffic like high-definition video, music, and gaming.

Figure 2 Dual-Radio Application

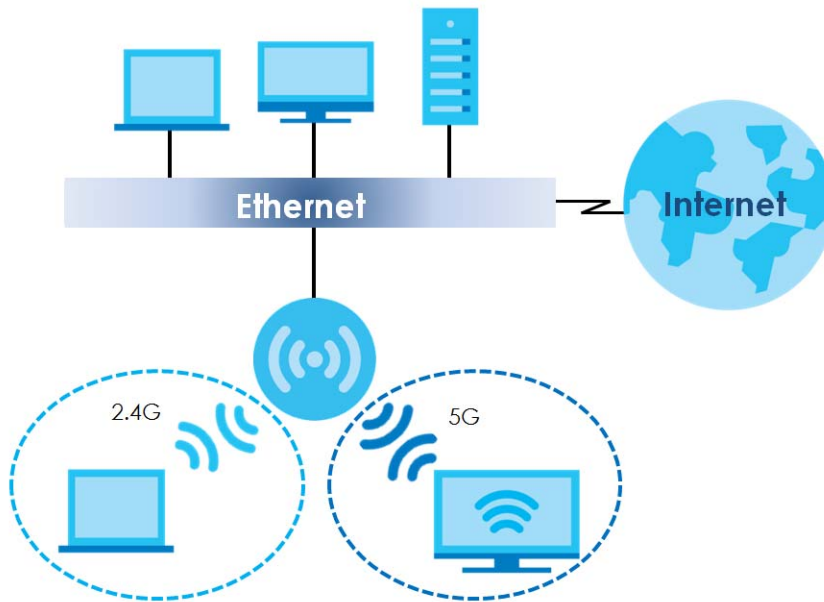

1.1.4 Root AP

In Root AP mode, the NWA/WAC (**Z**) can act as the root AP in a wireless network and also allow repeaters (**X** and **Y**) to extend the range of its wireless network at the same time. In the figure below, both clients **A**, **B** and **C** can access the wired network through the root AP.

Figure 3 Root AP Application

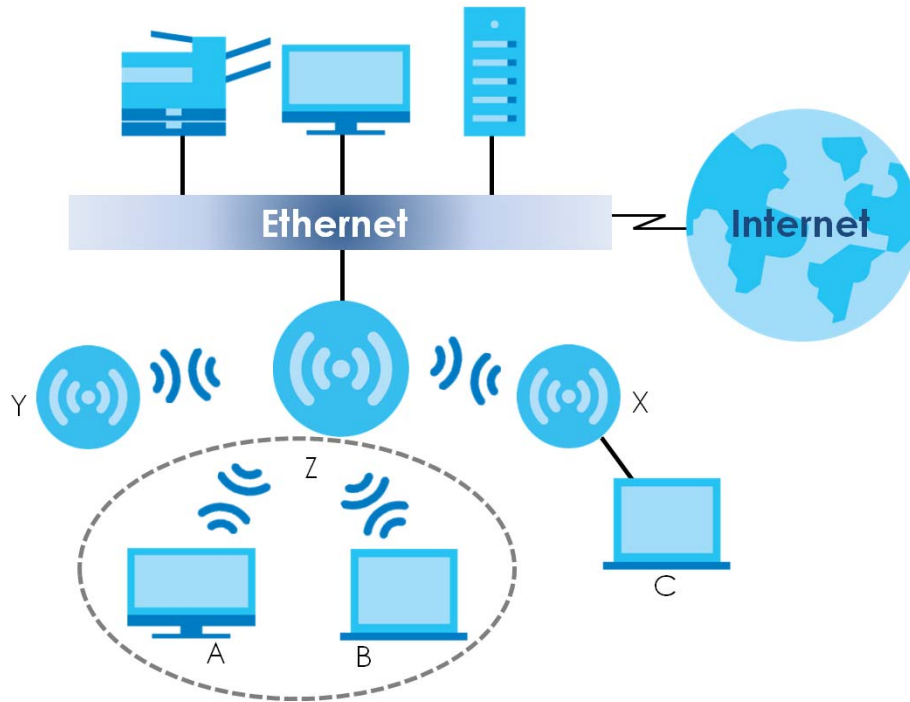

On the NWA/WAC in Root AP mode, you can have multiple SSIDs active for regular wireless connections and one SSID for the connection with a repeater (repeater SSID). Wireless clients can use either SSID to associate with the NWA/WAC in Root AP mode. A repeater must use the repeater SSID to connect to the NWA/WAC in Root AP mode.

When the NWA/WAC is in Root AP mode, repeater security between the NWA/WAC and other repeater is independent of the security between the wireless clients and the AP or repeater. When repeater security is enabled, both APs and repeaters must use the same pre-shared key. See [Section 7.2 on page 85](#) and [Section 12.2 on page 130](#) for more details.

Unless specified, the term "security settings" refers to the traffic between the wireless clients and the AP. At the time of writing, repeater security is compatible with the NWA/WAC only.

1.1.5 Repeater

The NWA/WAC can act as a wireless network repeater to extend a root AP's wireless network range, and also establish wireless connections with wireless clients.

Using Repeater mode, your NWA/WAC can extend the range of the WLAN. In the figure below, the NWA/WAC in Repeater mode (**Z**) has a wireless connection to the NWA/WAC in Root AP mode (**X**) which is connected to a wired network and also has a wireless connection to another NWA/WAC in Repeater mode (**Y**) at the same time. **Z** and **Y** act as repeaters that forward traffic between associated wireless clients and the wired LAN. Clients **A** and **B** access the AP and the wired network behind the AP through repeaters **Z** and **Y**.

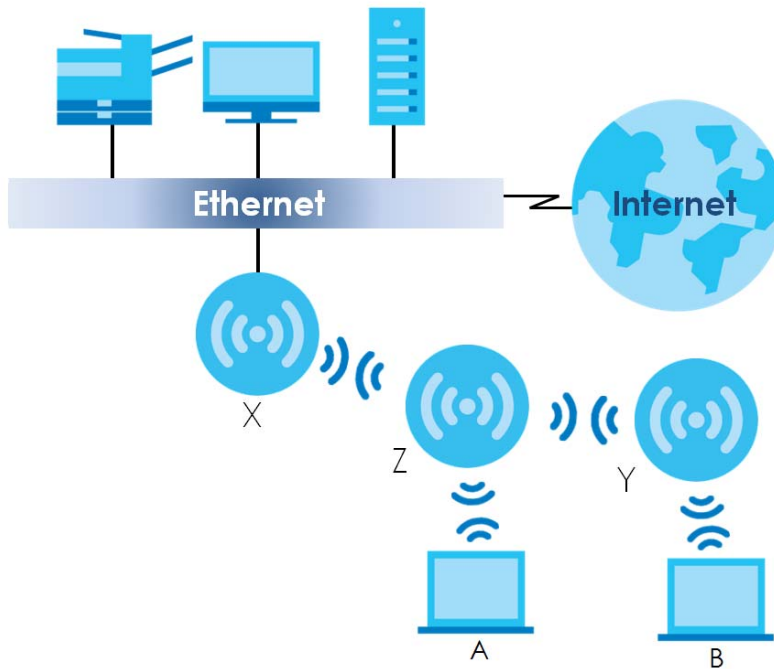
Figure 4 Repeater Application

When the NWA/WAC is in Repeater mode, repeater security between the NWA/WAC and other repeater is independent of the security between the wireless clients and the AP or repeater. When repeater security is enabled, both APs and repeaters must use the same pre-shared key. See [Section 7.2 on page 85](#) and [Section 12.2 on page 130](#) for more details.

Once the security settings of peer sides match one another, the connection between devices is made.

At the time of writing, repeater security is compatible with the NWA/WAC only.

1.2 Ways to Manage the NWA/WAC

You can use the following ways to manage the NWA/WAC.

Web Configurator

The Web Configurator allows easy NWA/WAC setup and management using an Internet browser. This User's Guide provides information about the Web Configurator.

Command-Line Interface (CLI)

The CLI allows you to use text-based commands to configure the NWA/WAC. You can access it using remote management (for example, SSH or Telnet). See the Command Reference Guide for more information.

File Transfer Protocol (FTP)

This protocol can be used for firmware upgrades and configuration backup and restore.

Simple Network Management Protocol (SNMP)

The NWA/WAC can be monitored by an SNMP manager. See the SNMP chapter in this User's Guide.

1.3 Good Habits for Managing the NWA/WAC

Do the following things regularly to make the NWA/WAC more secure and to manage it more effectively.

- Change the password often. Use a password that's not easy to guess and that consists of different types of characters, such as numbers and letters.
- Write down the password and put it in a safe place.
- Back up the configuration (and make sure you know how to restore it). Restoring an earlier working configuration may be useful if the device becomes unstable or even crashes. If you forget your password, you will have to reset the NWA/WAC to its factory default settings. If you backed up an earlier configuration file, you won't have to totally re-configure the NWA/WAC; you can simply restore your last configuration.

1.4 Hardware Connections

See your Quick Start Guide for information on making hardware connections.

1.5 NWA5301-NJ Hardware

1.5.1 110 Punch-Down Block

This section shows you how to use a punch-down tool to seat an 8-wire Ethernet cable to the 110 punch-down block. You can connect a PoE switch to the 110 punch-down block to provide power and Internet access to the NWA through this connection. An 8-pin Ethernet cable has four pairs of color coded wires.

- 1 Cut out one and a half inches of the jacket from the Ethernet cable to expose the wires.
- 2 Untwist the wire pairs no more than one inch.
- 3 Match each wire to the correct slot according to the color codes for wiring shown below.

NWA Rear Panel

Table 6 Color Codes for 110 Punch Down Block Wiring

PIN#	WIRE COLOR
1	White/Orange
2	Orange
3	White/Green
4	Blue
5	White/Blue
6	Green
7	White/Brown
8	Brown

- 4 Use a punch-down tool to seat the wires down properly into the slot.

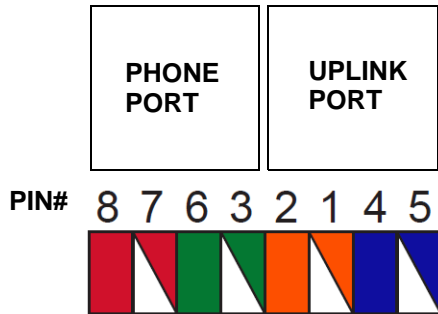
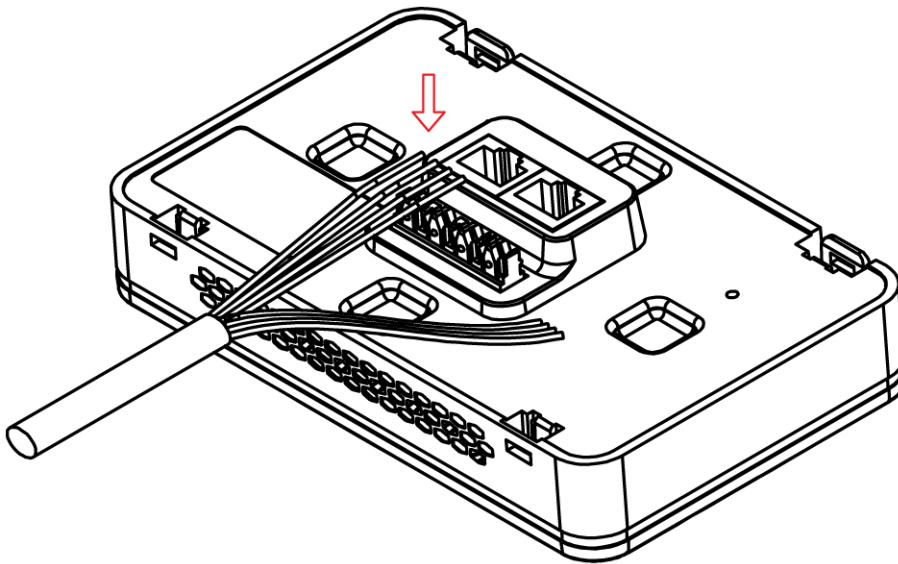

- 5 Trim any excess wires. Place the dust caps over the terminated wires.

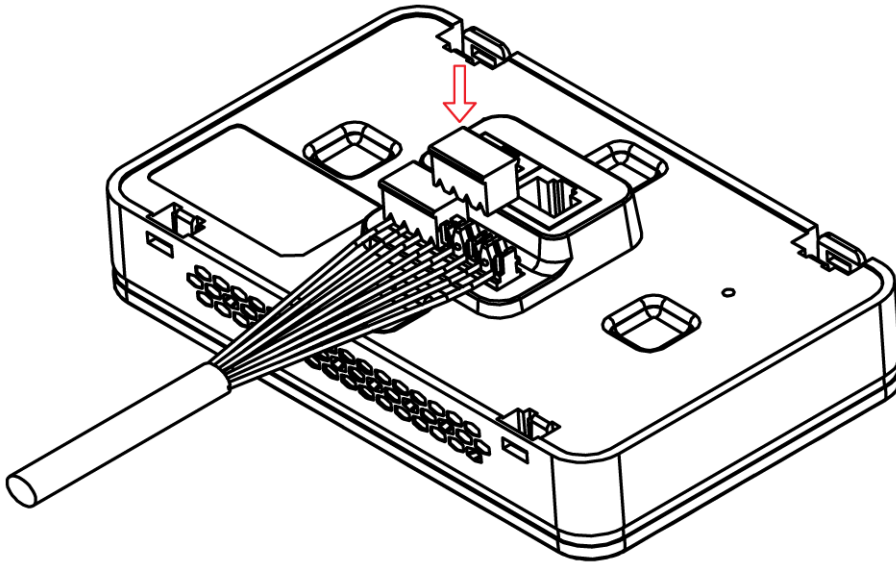

1.5.2 Phone Port

Connect a digital telephone to the RJ-45 **PHONE** port at the bottom of the NWA to forward voice traffic to/from the telephone switchboard that is connected to the RJ-45 **PHONE** port on the back of the NWA. The NWA does not support VoIP (Voice over Internet Protocol) and the **PHONE** port is NOT for making calls over the regular networking network (PSTN), either.

1.5.3 Console Port

To use the CLI commands to configure the NWA, connect an RJ-45-to-DB-9 cable to the **PHONE** port at the bottom of the NWA.

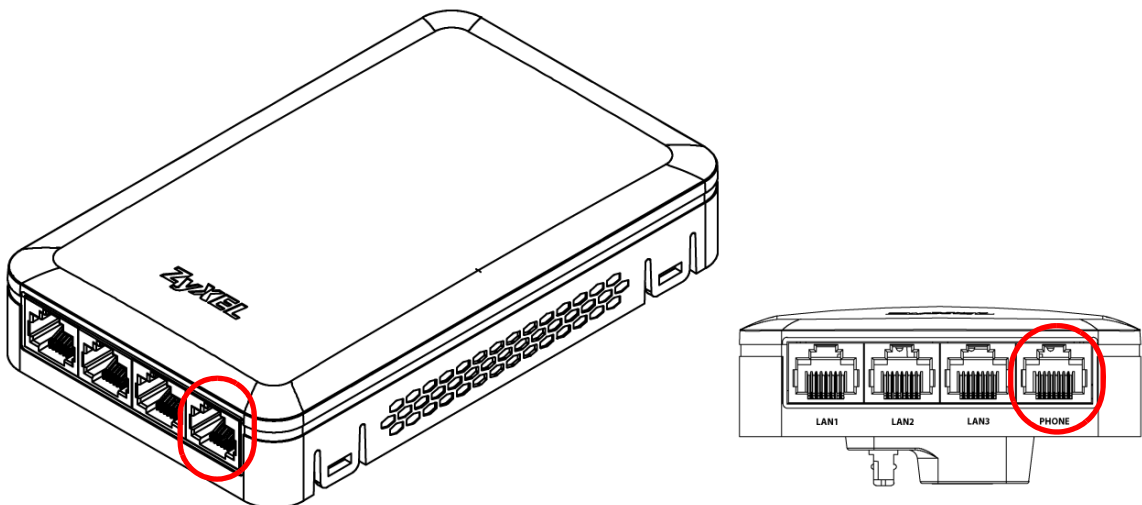

For local management, you can use a computer with terminal emulation software configured to the following parameters:

- VT100 terminal emulation

- 115200 bps
- No parity, 8 data bits, 1 stop bit
- No flow control

The following table shows you the wire color codes and pin assignment for the console cable.

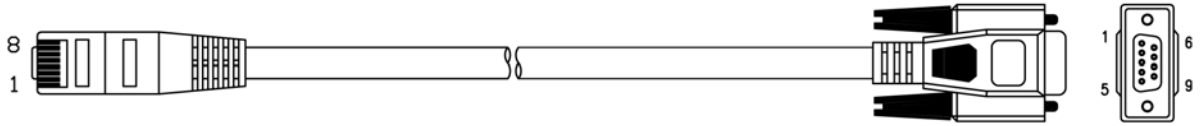

Table 7 RJ45-to-DB-9 Console Cable Color Codes

RJ45 PIN#	WIRE COLOR	DB-9 PIN#
1	Black	1
7	Brown	2
2	Blue	3
8	Purple	5

1.6 LEDs

The LEDs of your WAC6500 and NWA5301 can be controlled by using the Suppression feature such that the LEDs stay lit (ON) or OFF after the device is ready.

The WAC6500 also features Locator LED which allows you to see the actual location of the WAC6500 between several devices in the network.

Following are LED descriptions for the NWA/WAC series models.

1.6.1 WAC6502D-E, WAC6502D-S, and WAC6503D-S

The LEDs will stay ON when the WAC6500 Series is ready. You can change this setting in the **Maintenance > LEDs > Suppression** screen.

Figure 5 WAC6500 Series LEDs



The following table describes the LEDs.

Table 8 WAC6500 Series LEDs



LED	COLOR	STATUS	DESCRIPTION
PWR/SYS 	Red	Slow Blinking (On for 1s, Off for 1s)	The WAC is booting up.
	Green	On	
	Red	Off	The WAC is ready for use.
	Green	On	
	Red	On	There is system error and the WAC cannot boot up, or the WAC suffered a system failure.
	Green	Off	
	Red	Fast Blinking (on for 50ms, Off for 50ms)	The WAC is doing firmware upgrade.
	Green	Off	
	Red	Slow Blinking (blink for 3 times, Off for 3s)	The Uplink port is disconnected.
	Green	Off	
	Red	Slow Blinking (blink for 2 times, Off for 3s)	The wireless module of the WAC is disabled or failed.
Green	Off		
Management 	Green	On	The WAC AP is managed by a controller.
		Slow Blinking (blink for 3 times, Off for 3s)	The WAC AP is searching (discovery) for a controller.
		Off	The WAC AP is in standalone mode.
WLAN 	Green	On	The 2.4 GHz WLAN is active.
		Off	The 2.4 GHz WLAN is not active.

Table 8 WAC6500 Series LEDs (continued)

LED	COLOR	STATUS	DESCRIPTION
WLAN (i) 5G	Green	On	The 5 GHz WLAN is active.
		Off	The 5 GHz WLAN is not active.
UPLINK ↻	Amber/ Green	On	Amber - The port is operating as a 100-Mbps connection. Green - The port is operating as a Gigabit connection (1000 Mbps).
		Blinking	The WAC is sending/receiving data through the port.
		Off	The port is not connected.
LAN ↻	Amber/ Green	On	Amber - The port is operating as a 100-Mbps connection. Green - The port is operating as a Gigabit connection (1000 Mbps).
		Blinking	The LAN port is sending/receiving data through the port.
		Off	The LAN port is not connected.
Locator ☀	White	Blinking	The Locator is activated and will show the actual location of the WAC between several devices in the network.
		Off	The Locator function is off.

1.6.2 NWA1123-AC PRO and WAC6103D-I

The LEDs will stay ON when the NWA1123-AC PRO or WAC6103D-I is ready. You can change this setting in the **Maintenance > LEDs > Suppression** screen.

Figure 6 NWA1123-AC PRO and WAC6103D-I LEDs

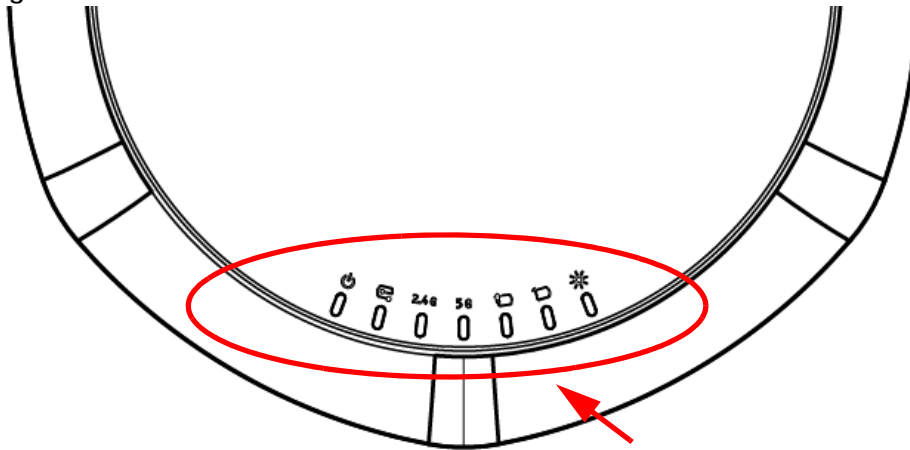

The following table describes the LEDs.

Table 9 NWA1123-AC PRO and WAC6103D-I LEDs





LED	COLOR	STATUS	DESCRIPTION
PWR/SYS 	Red	Slow Blinking (On for 1s, Off for 1s)	The NWA/WAC is booting up.
	Green	On	
	Red	Off	The NWA/WAC is ready for use.
	Green	On	
	Red	On	There is system error and the NWA/WAC cannot boot up, or the NWA/WAC suffered a system failure.
	Green	Off	
	Red	Fast Blinking (on for 50ms, Off for 50ms)	The NWA/WAC is doing firmware upgrade.
	Green	Off	
	Red	Slow Blinking (blink for 3 times, Off for 3s)	The Uplink port is disconnected.
	Green	Off	
Red	Slow Blinking (blink for 2 times, Off for 3s)	The wireless module of the NWA/WAC is disabled or failed.	
			Green
Management 	Green	On	The NWA/WAC is managed by a controller.
		Slow Blinking (blink for 3 times, Off for 3s)	The NWA/WAC is searching (discovery) for a controller.
		Off	The NWA/WAC is in standalone mode.
WLAN 2.4G	Green	On	The antenna switch is set to "Ceiling" for the radio. The 2.4 GHz WLAN is active.
	Amber	On	The antenna switch is set to "Wall" for the radio. The 2.4 GHz WLAN is active.
		Off	The 2.4 GHz WLAN is not active.
WLAN 5G	Green	On	The antenna switch is set to "Ceiling" for the radio. The 5 GHz WLAN is active.
	Amber	On	The antenna switch is set to "Wall" for the radio. The 5 GHz WLAN is active.
		Off	The 5 GHz WLAN is not active.
UPLINK 	Amber/ Green	On	Amber - The port is operating as a 100-Mbps connection. Green - The port is operating as a Gigabit connection (1000 Mbps).
		Blinking	The NWA/WAC is sending/receiving data through the port.
		Off	The port is not connected.
LAN 	Amber/ Green	On	Amber - The port is operating as a 100-Mbps connection. Green - The port is operating as a Gigabit connection (1000 Mbps).
		Blinking	The LAN port is sending/receiving data through the port.
		Off	The LAN port is not connected.

Table 9 NWA1123-AC PRO and WAC6103D-I LEDs (continued)

LED	COLOR	STATUS	DESCRIPTION
Locator 	White	Blinking	The Locator is activated and will show the actual location of the NWA/WAC between several devices in the network.
		Off	The Locator function is off.

1.6.3 NWA5301-NJ

The LEDs automatically turn off when the NWA5301-NJ is ready. You can press the **LED ON** button for one second to turn on the LEDs again. The LEDs will blink and turn off after two minutes.

Figure 7 NWA5301-NJ LEDs



The following are the LED descriptions for your NWA5301-NJ.

Table 10 NWA5301-NJ LEDs





LABEL	COLOR	STATUS	DESCRIPTION
PWR/SYS 	Amber	Slow Blinking (On for 1s, Off for 1s)	The NWA is booting up.
	Green	On	
	Amber	Off	The NWA is ready for use.
	Green	On	
	Amber	Slow Blinking (blink for 3 times, Off for 3s)	The NWA is discovering an AP controller
	Green	On	
	Amber	On	The NWA failed to boot up or is experiencing system failure.
	Green	Off	
	Amber	Fast Blinking (On for 50ms times, Off for 50ms)	The NWA is undergoing firmware upgrade.
	Green	Off	
	Amber	Slow Blinking (blink for 3 times, Off for 3s)	The Uplink port is disconnected.
	Green	Off	
	Amber	Slow Blinking (blink for 2 times, Off for 3s)	The wireless module of the WAC is disabled or failed.
Green	Off		
PoE 	Green	On	Power is supplied to the yellow PoE Ethernet port (LAN1).
		Off	There is no power supply.

Table 10 NWA5301-NJ LEDs (continued)

LABEL	COLOR	STATUS	DESCRIPTION
WLAN 	Green	On	The WLAN is active.
		Off	The WLAN is not active.
UPLINK 	Green	On	The port is connected.
		Blinking	The NWA is sending/receiving data through the port.
		Off	The port is not connected.
LAN1-3 	Green	On	The port is connected.
		Blinking	The NWA is sending/receiving data through the port.
		Off	The port is not connected.

1.6.4 NWA1123-ACv2, NWA5121-N, NWA5121-NI, NWA5123-AC and NWA5123-NI

The following are the LED descriptions for your NWA1123/5120 series.

Figure 8 NWA1123/5120 Series LED



The following are the LED descriptions for your NWA1123/5120 series.

Table 11 NWA1123/5120 Series LED

COLOR	STATUS	DESCRIPTION
Amber	Slow Blinking (On for 1s, Off for 1s)	The NWA is booting up.
Green	On	

Table 11 NWA1123/5120 Series LED (continued)

COLOR	STATUS	DESCRIPTION
Amber	Off	The NWA is ready for use.
Green	On	
Amber	Off	The NWA's wireless interface is activated.
Green	On	
Amber	Slow Blinking (blink for 3 times, Off for 3s)	The NWA is discovering an AP controller.
Green	On	
Amber	On	The NWA failed to boot up or is experience system failure.
Green	Off	
Amber	Fast Blinking (On for 50ms, Off for 50ms)	The NWA is undergoing firmware upgrade.
Green	Off	
Amber	Slow Blinking (blink for 3 times, Off for 3s)	The Uplink port is disconnected.
Green	Off	
Amber	Slow Blinking (blink for 2 times, Off for 3s)	The wireless LAN is disabled or fails.
Green	Off	

1.6.5 WAC5302D-S



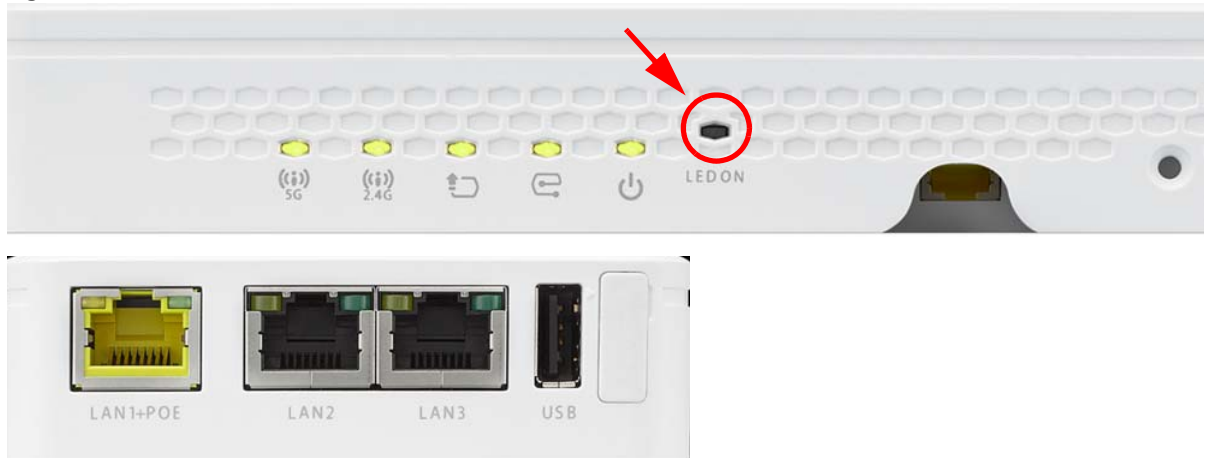

The LEDs automatically turn off when the WAC5302D-S is ready. You can press the **LED ON** button for one second to turn on the LEDs again. The LEDs will blink and turn off after two minutes.

Figure 9 WAC5302D-S LEDs



The following table describes the LEDs.

Table 12 WAC5302D-S LEDs

LED	COLOR	STATUS	DESCRIPTION
PWR/SYS 	Red	Slow Blinking (On for 1s, Off for 1s)	The WAC is booting up.
	Green	On	
	Red	Off	The WAC is ready for use.
	Green	On	
	Red	On	There is system error and the WAC cannot boot up, or the WAC suffered a system failure.
	Green	Off	
	Red	Fast Blinking (on for 50ms, Off for 50ms)	The WAC is doing firmware upgrade.
	Green	Off	
	Red	Slow Blinking (blink for 3 times, Off for 3s)	The Uplink port is disconnected.
	Green	Off	
	Red	Slow Blinking (blink for 2 times, Off for 3s)	The wireless module of the WAC is disabled or failed.
Green	Off		
Management 	Green	On	The WAC AP is managed by a controller.
		Slow Blinking (blink for 3 times, Off for 3s)	The WAC AP is searching (discovery) for a controller.
		Off	The WAC AP is in standalone mode.
UPLINK 	Amber/ Green	On	Amber - The port is operating as a 10/100-Mbps connection. Green - The port is operating as a Gigabit connection (1000 Mbps).
		Blinking	The WAC is sending/receiving data through the port.
		Off	The port is not connected.
WLAN 	Green	On	The 2.4 GHz WLAN is active.
		Off	The 2.4 GHz WLAN is not active.
WLAN 	Green	On	The 5 GHz WLAN is active.
		Off	The 5 GHz WLAN is not active.
LAN	Amber/ Green	On	Amber - The port is operating as a 10/100-Mbps connection. Green - The port is operating as a Gigabit connection (1000 Mbps).
		Blinking	The LAN port is sending/receiving data through the port.
		Off	The LAN port is not connected.

1.6.6 NWA1123-AC HD, NWA5123-AC HD and WAC6303D-S

The following are the LED descriptions for your NWA/WAC.

Figure 10 NWA1123-AC HD, NWA5123-AC HD and WAC6303D-S LED

The following are the LED descriptions for your NWA/WAC.

Table 13 NWA1123-AC HD, NWA5123-AC HD and WAC6303D-S LED

COLOR	STATUS	DESCRIPTION
Amber	Slow Blinking (On for 1s, Off for 1s)	The NWA/WAC is booting up.
Green	On	
Amber	Slow Blinking (blink for 3 times, Off for 3s)	The NWA/WAC is discovering an AP controller.
Green	On	
Green	On	The NWA/WAC is ready for use, the NWA/WAC's wireless interface is activated, and/or wireless clients are connected to the NWA/WAC.
Bright Blue	On	The NWA/WAC's wireless interface is activated, but there are no wireless clients connected.
Red	On	The NWA/WAC failed to boot up or is experience system failure.
Red	Fast Blinking (On for 50ms, Off for 50ms)	The NWA/WAC is undergoing firmware upgrade.
Red	Slow Blinking (blink for 3 times, Off for 3s)	The Uplink port is disconnected.
Green	Slow Blinking (blink for 1 time, Off for 1s)	The wireless LAN is disabled or fails.
Blue	Slow Blinking (blink for 1 time, Off for 1s)	The NWA/WAC is checking for an available 5GHz channel.

1.7 Starting and Stopping the NWA/WAC

Here are some of the ways to start and stop the NWA/WAC.

Always use Maintenance > Shutdown or the `shutdown` command before you turn off the NWA/WAC or remove the power. Not doing so can cause the firmware to become corrupt.

Table 14 Starting and Stopping the NWA/WAC

METHOD	DESCRIPTION
Turning on the power	A cold start occurs when you turn on the power to the NWA/WAC. The NWA/WAC powers up, checks the hardware, and starts the system processes.
Rebooting the NWA/WAC	A warm start (without powering down and powering up again) occurs when you use the Reboot button in the Reboot screen or when you use the <code>reboot</code> command. The NWA/WAC writes all cached data to the local storage, stops the system processes, and then does a warm start.
Using the RESET button	If you press the RESET button on the back of the NWA/WAC, the NWA/WAC sets the configuration to its default values and then reboots. See Section 22.6 on page 212 for more information.
Clicking Maintenance > Shutdown > Shutdown or using the <code>shutdown</code> command	Clicking Maintenance > Shutdown > Shutdown or using the <code>shutdown</code> command writes all cached data to the local storage and stops the system processes. Wait for the device to shut down and then manually turn off or remove the power. It does not turn off the power.
Disconnecting the power	Power off occurs when you turn off the power to the NWA/WAC. The NWA/WAC simply turns off. It does not stop the system processes or write cached data to local storage.

The NWA/WAC does not stop or start the system processes when you apply configuration files or run shell scripts although you may temporarily lose access to network resources.

CHAPTER 2

The Web Configurator

2.1 Overview

The NWA/WAC Web Configurator allows easy management using an Internet browser. Browsers supported are:

- Firefox 36.0.1 or later
- Chrome 41.0 or later
- IE 10 or later

The recommended screen resolution is 1024 x 768 pixels and higher.

2.2 Accessing the Web Configurator

- 1 Make sure your NWA/WAC is working in standalone AP mode (see [Section 1.1.1 on page 17](#)) and hardware is properly connected. See the Quick Start Guide.
- 2 If the NWA/WAC and your computer are not connected to a DHCP server, make sure your computer's IP address is in the range between "192.168.1.3" and "192.168.1.254".
- 3 Browse to the NWA/WAC's DHCP-assigned IP address or <http://192.168.1.2>. The **Login** screen appears.

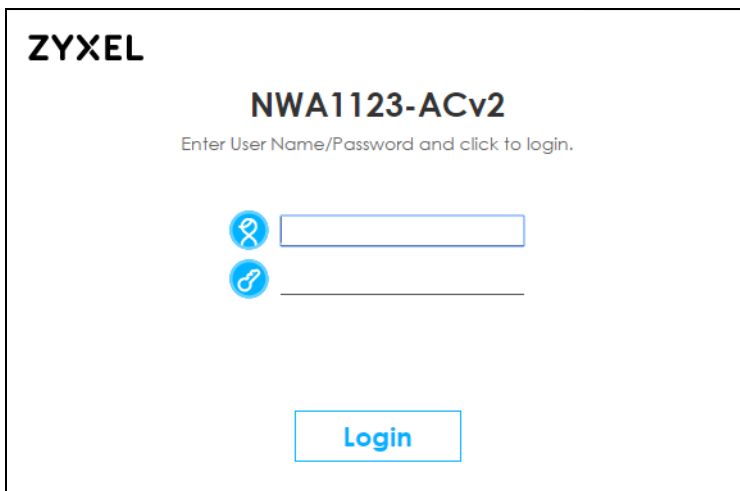

ZYXEL

NWA1123-ACv2

Enter User Name/Password and click to login.

Login

- 4 Enter the user name (default: "admin") and password (default: "1234"). Click **Login**.

- 5 If you logged in using the default user name and password, the **Update Admin Info** screen appears. Otherwise, the dashboard appears.

ZYXEL

NWA1123-ACv2

Update Admin Info

As a security precaution, it is highly recommended that you change the admin password.

New Password

Retype to Confirm

(max. 63 alphanumeric, printable characters and no spaces)

Apply **Ignore**

The **Update Admin Info** screen appears every time you log in using the default user name and default password. If you change the password for the default user account, this screen does not appear anymore.

2.3 Navigating the Web Configurator

The following summarizes how to navigate the web configurator from the **Dashboard** screen. This guide uses the NWA1123-ACv2 screens as an example. The screens may vary slightly for different models.

Figure 11 The Web Configurator's Main Screen

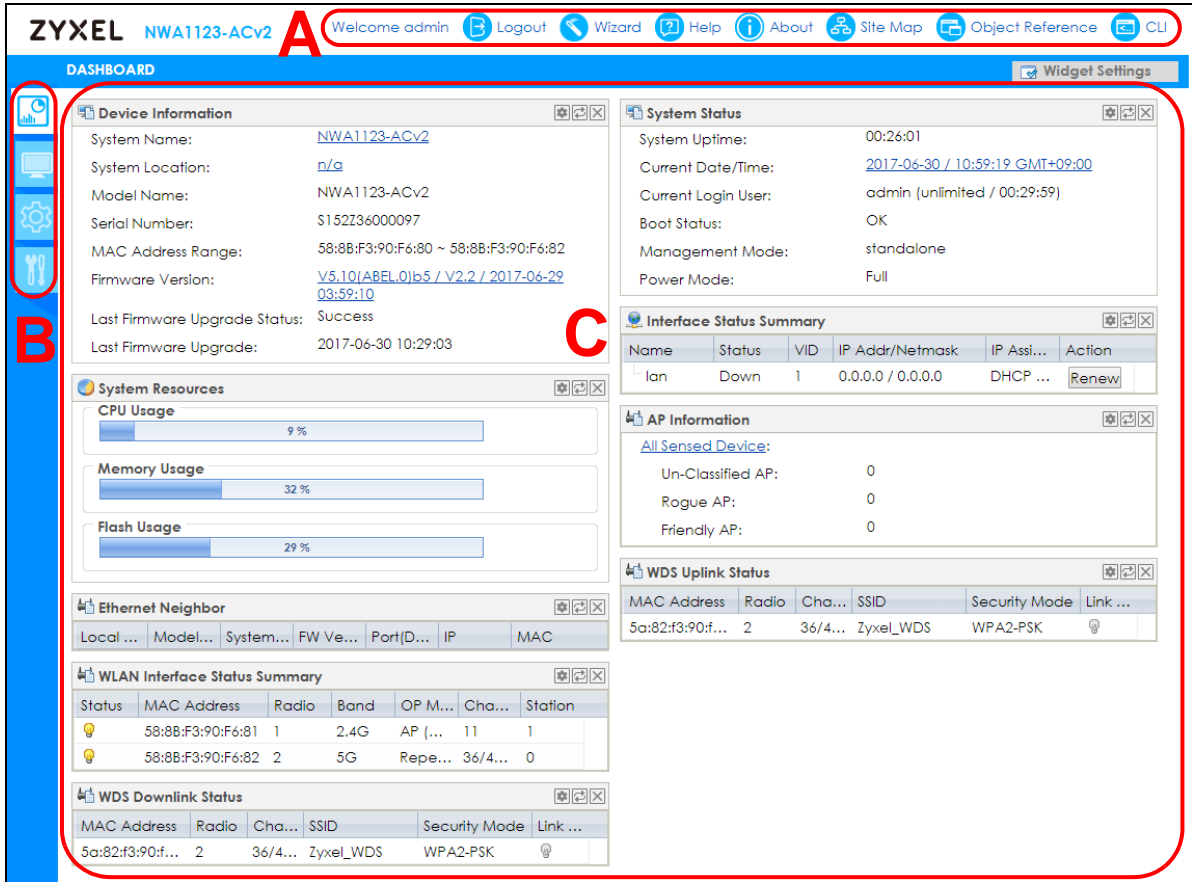

The Web Configurator's main screen is divided into these parts:

- A - Title Bar
- B - Navigation Panel
- C - Main Window

2.3.1 Title Bar

The title bar provides some useful links that always appear over the screens below, regardless of how deep into the Web Configurator you navigate.

Figure 12 Title Bar



The icons provide the following functions.

Table 15 Title Bar: Web Configurator Icons

LABEL	DESCRIPTION
Logout	Click this to log out of the Web Configurator.
Wizard	Click this to open the wizard. See Chapter 3 on page 47 for more information.
Help	Click this to open the help page for the current screen.

Table 15 Title Bar: Web Configurator Icons (continued)

LABEL	DESCRIPTION
About	Click this to display basic information about the NWA/WAC.
Site Map	Click this to see an overview of links to the Web Configurator screens.
Object Reference	Click this to open a screen where you can check which configuration items reference an object.
CLI	Click this to open a popup window that displays the CLI commands sent by the Web Configurator.

About

Click **About** to display basic information about the NWA/WAC.

Figure 13 About



The following table describes labels that can appear in this screen.

Table 16 About

LABEL	DESCRIPTION
Boot Module	This shows the version number of the software that handles the booting process of the NWA/WAC.
Current Version	This shows the firmware version of the NWA/WAC.
Released Date	This shows the date (yyyy-mm-dd) and time (hh:mm:ss) when the firmware is released.
OK	Click this to close the screen.

Site Map

Click **Site MAP** to see an overview of links to the Web Configurator screens. Click a screen's link to go to that screen.

Figure 14 Site Map

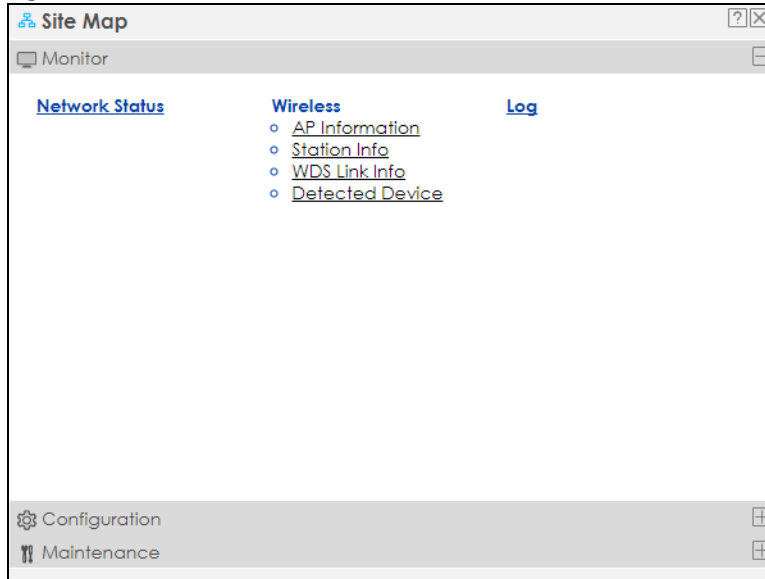

Object Reference

Click **Object Reference** to open the **Object Reference** screen. Select the type of object and the individual object and click **Refresh** to show which configuration settings reference the object.

Figure 15 Object Reference

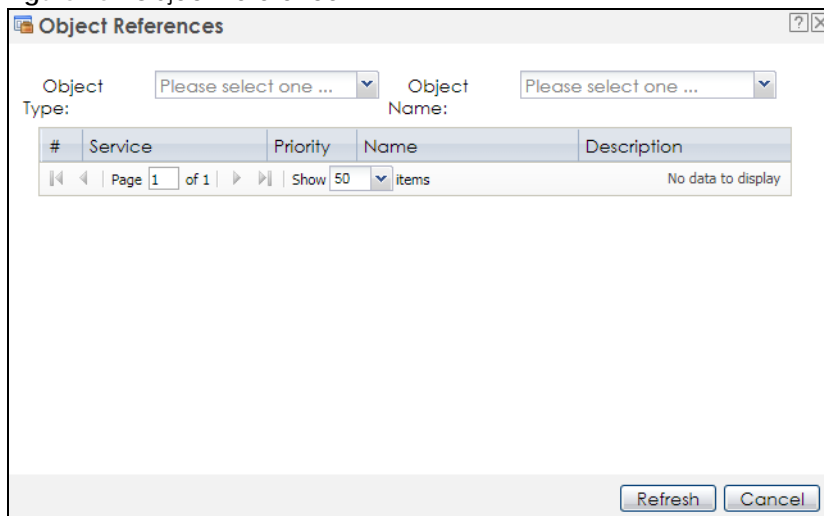

The fields vary with the type of object. The following table describes labels that can appear in this screen.

Table 17 Object References

LABEL	DESCRIPTION
Object Name	This identifies the object for which the configuration settings that use it are displayed. Click the object's name to display the object's configuration screen in the main window.
#	This field is a sequential value, and it is not associated with any entry.
Service	This is the type of setting that references the selected object. Click a service's name to display the service's configuration screen in the main window.

Table 17 Object References (continued)

LABEL	DESCRIPTION
Priority	If it is applicable, this field lists the referencing configuration item's position in its list, otherwise N/A displays.
Name	This field identifies the configuration item that references the object.
Description	If the referencing configuration item has a description configured, it displays here.
Refresh	Click this to update the information in this screen.
Cancel	Click Cancel to close the screen.

CLI Messages

Click **CLI** to look at the CLI commands sent by the Web Configurator. These commands appear in a popup window, such as the following.

Figure 16 CLI Messages

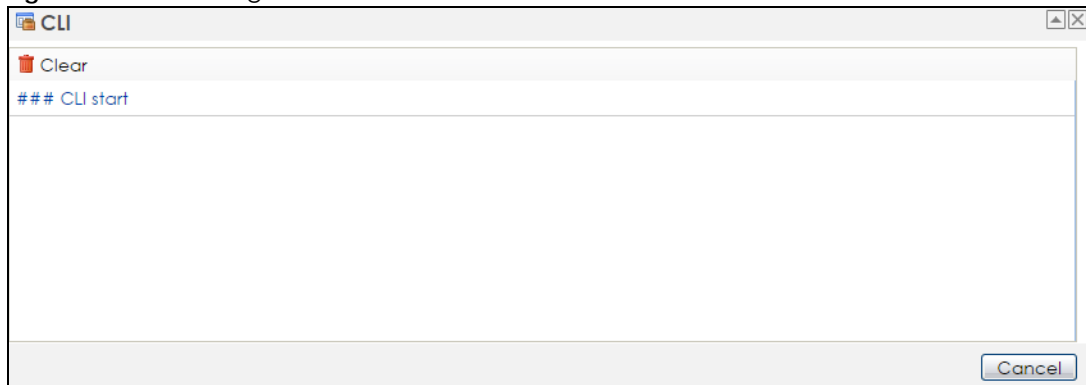

Click **Clear** to remove the currently displayed information.

Note: See the Command Reference Guide for information about the commands.

2.3.2 Navigation Panel

Use the menu items on the navigation panel to open screens to configure NWA/WAC features. Click the arrow in the middle of the right edge of the navigation panel to hide the navigation panel menus or drag it to resize them. The following sections introduce the NWA/WAC's navigation panel menus and their screens.

Figure 17 Navigation Panel

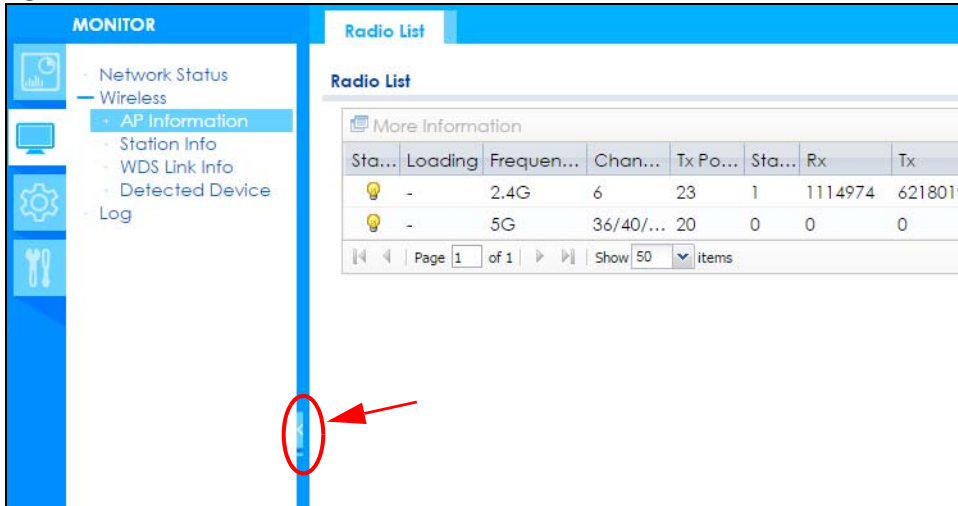

Dashboard

The dashboard displays general device information, system status, system resource usage, and interface status in widgets that you can re-arrange to suit your needs.

For details on the Dashboard's features, see [Chapter 4 on page 54](#).

Monitor Menu

The monitor menu screens display status and statistics information.

Table 18 Monitor Menu Screens Summary

FOLDER OR LINK	TAB	FUNCTION
Network Status	Network Status	Display general LAN interface information and packet statistics.
Wireless		
AP Information	Radio List	Display information about the radios of the connected APs.
Station Info	Station List	Display information about the connected stations.
WDS Link Info	WDS Link Info	Display statistics about the NWA/WAC's WDS (Wireless Distribution System) connections.
Detected Device	Detected Device	Display information about suspected rogue APs.
Log	View Log	Display log entries for the NWA/WAC.

Configuration Menu

Use the configuration menu screens to configure the NWA/WAC's features.

Table 19 Configuration Menu Screens Summary

FOLDER OR LINK	TAB	FUNCTION
Network	IP Setting	Configure the IP address for the NWA/WAC Ethernet interface.
	VLAN	Manage the Ethernet interface VLAN settings.
	AC Discovery	Configures the NWA/WAC's AP Controller settings.

Table 19 Configuration Menu Screens Summary (continued)

FOLDER OR LINK	TAB	FUNCTION
Wireless		
AP Management	WLAN Setting	Manage the NWA/WAC's general wireless settings.
Rogue AP	Rogue/Friendly AP List	Configure how the NWA/WAC monitors for rogue APs.
Load Balancing	Load Balancing	Configure load balancing for traffic moving to and from wireless clients.
DCS	DCS	Configure dynamic wireless channel selection.
Bluetooth	Advertising Settings	Configure the beacon ID(s) to be included in the Bluetooth advertising packet.
Object		
User	User	Create and manage users.
	Setting	Manage default settings for all users, general settings for user sessions, and rules to force user authentication.
AP Profile	Radio	Create and manage wireless radio settings files that can be associated with different APs.
	SSID	Create and manage wireless SSID, security, MAC filtering, and layer-2 isolation files that can be associated with different APs.
MON Profile	MON Profile	Create and manage rogue AP monitoring files that can be associated with different APs.
WDS Profile	WDS	Create and manage WDS profiles that can be used to connect to different APs in WDS.
Certificate	My Certificates	Create and manage the NWA/WAC's certificates.
	Trusted Certificates	Import and manage certificates from trusted sources.
System		
Host Name	Host Name	Configure the system and domain name for the NWA/WAC.
Date/Time	Date/Time	Configure the current date, time, and time zone in the NWA/WAC.
WWW	Service Control	Configure HTTP, HTTPS, and general authentication.
SSH	SSH	Configure SSH server and SSH service settings.
TELNET	TELNET	Configure telnet server settings for the NWA/WAC.
FTP	FTP	Configure FTP server settings.
SNMP	SNMP	Configure SNMP communities and services.
Log & Report		
Email Daily Report	Email Daily Report	Configure where and how to send daily reports and what reports to send.
Log Setting	Log Setting	Configure the system log, e-mail logs, and remote syslog servers.

Maintenance Menu

Use the maintenance menu screens to manage configuration and firmware files, run diagnostics, and reboot or shut down the NWA/WAC.

Table 20 Maintenance Menu Screens Summary

FOLDER OR LINK	TAB	FUNCTION
File Manager	Configuration File	Manage and upload configuration files for the NWA/WAC.
	Firmware Package	View the current firmware version and to upload firmware.
	Shell Script	Manage and run shell script files for the NWA/WAC.
Diagnostics	Diagnostics	Collect diagnostic information.
LEDs	Suppression	Enable this feature to keep the LEDs off after the NWA/WAC starts.
	Locator	Enable this feature to see the actual location of the NWA/WAC between several devices in the network.
Antenna	Antenna Switch	Change antenna orientation for the radios.
Reboot	Reboot	Restart the NWA/WAC.
Shutdown	Shutdown	Turn off the NWA/WAC.

2.3.3 Warning Messages

Warning messages, such as those resulting from misconfiguration, display in a pop up window.

Figure 18 Warning Message

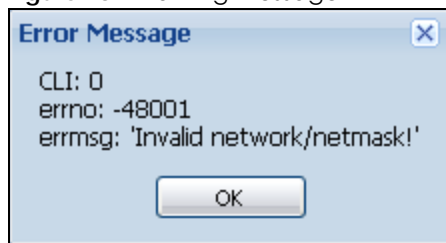

2.3.4 Tables and Lists

The Web Configurator tables and lists are quite flexible and provide several options for how to display their entries.

2.3.4.1 Manipulating Table Display

Here are some of the ways you can manipulate the Web Configurator tables.

- 1 Click a column heading to sort the table's entries according to that column's criteria.

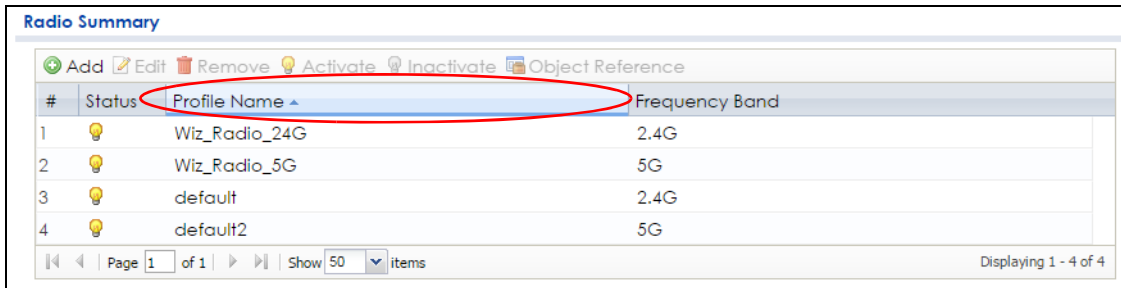

- 2 Click the down arrow next to a column heading for more options about how to display the entries. The options available vary depending on the type of fields in the column. Here are some examples of what you can do:
 - Sort in ascending alphabetical order
 - Sort in descending (reverse) alphabetical order
 - Select which columns to display
 - Group entries by field
 - Show entries in groups
 - Filter by mathematical operators (<, >, or =) or searching for text.

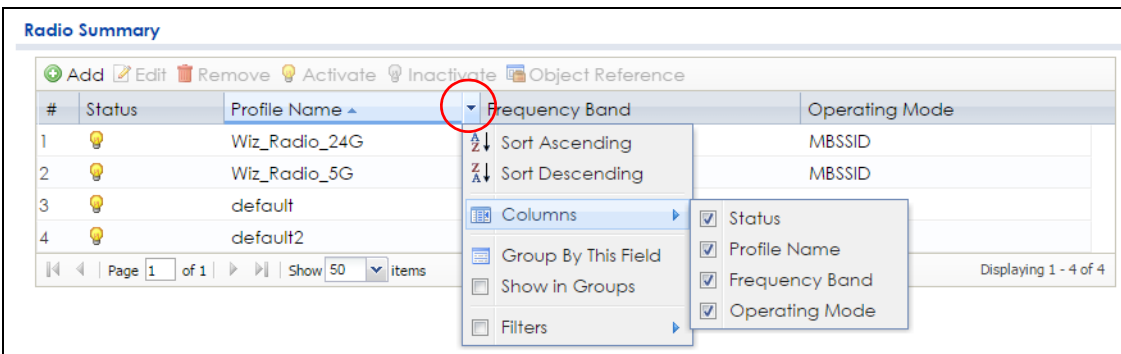

- 3 Select a column heading cell's right border and drag to re-size the column.

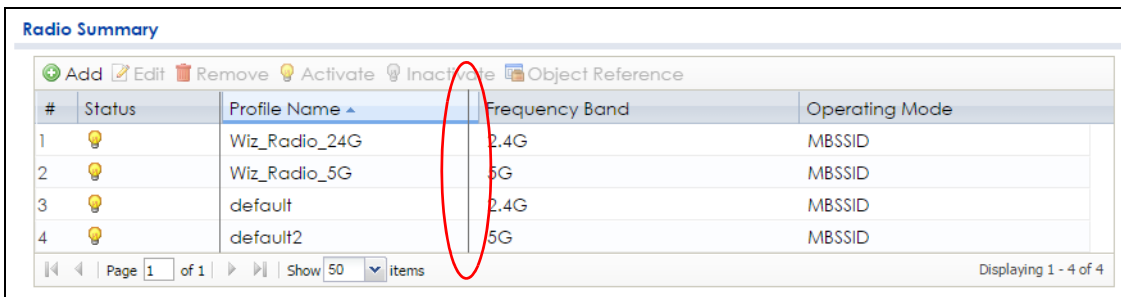

- 4 Select a column heading and drag and drop it to change the column order. A green check mark displays next to the column's title when you drag the column to a valid new location.

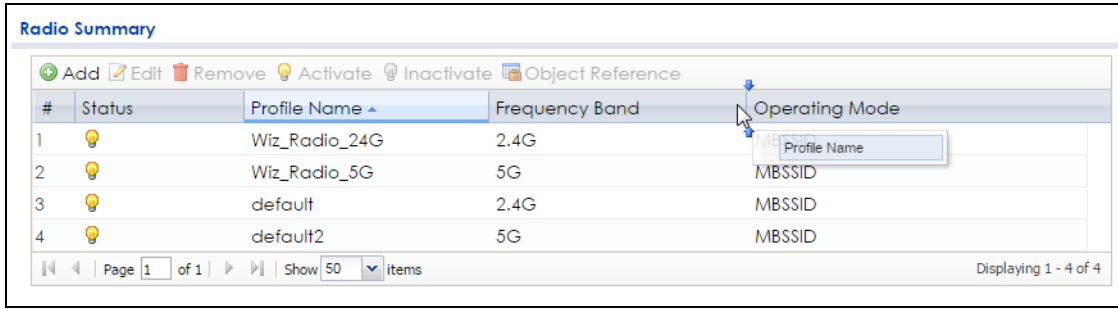

- 5 Use the icons and fields at the bottom of the table to navigate to different pages of entries and control how many entries display at a time.

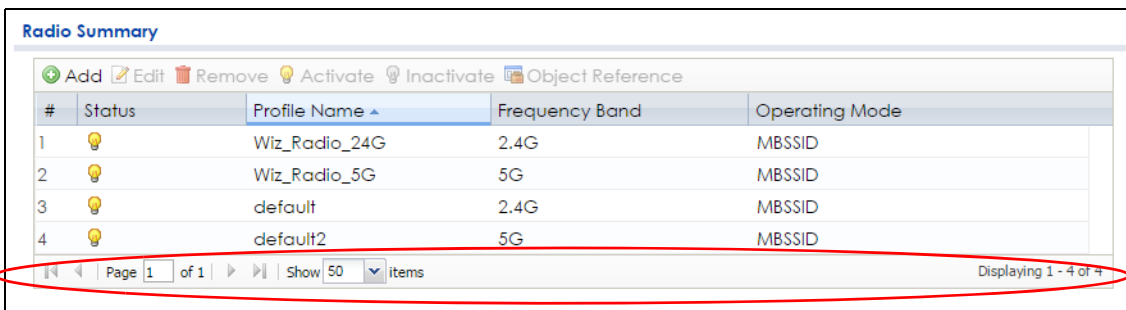

2.3.4.2 Working with Table Entries

The tables have icons for working with table entries. A sample is shown next. You can often use the [Shift] or [Ctrl] key to select multiple entries to remove, activate, or deactivate.

Table 21 Common Table Icons

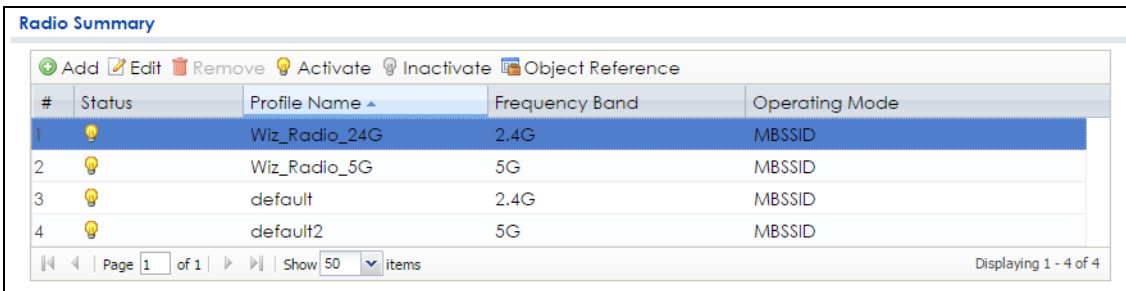

Here are descriptions for the most common table icons.

Table 22 Common Table Icons

LABEL	DESCRIPTION
Add	Click this to create a new entry. For features where the entry's position in the numbered list is important (features where the NWA/WAC applies the table's entries in order like the firewall for example), you can select an entry and click Add to create a new entry after the selected entry.
Edit	Double-click an entry or select it and click Edit to open a screen where you can modify the entry's settings. In some tables you can just click a table entry and edit it directly in the table. For those types of tables small red triangles display for table entries with changes that you have not yet applied.

Table 22 Common Table Icons (continued)

LABEL	DESCRIPTION
Remove	To remove an entry, select it and click Remove . The NWA/WAC confirms you want to remove it before doing so.
Activate	To turn on an entry, select it and click Activate .
Inactivate	To turn off an entry, select it and click Inactivate .
Object Reference	Select an entry and click Object Reference to open a screen that shows which settings use the entry.

CHAPTER 3

Setup Wizard

3.1 Accessing the Wizard

When you log into the Web Configurator for the first time or when you reset the NWA/WAC to its default configuration, the wizard screen displays.

Note: If you have already configured the wizard screens and want to open it again, click the **Wizard** icon on the upper right corner of any Web Configurator screen.

3.2 Using the Wizard

This wizard helps you configure the NWA/WAC IP address, change time zone, daylight saving and radio settings, and edit an SSID profile to change general wireless and wireless security settings.

3.2.1 Country Code

The welcome screen displays. Select the country where the NWA/WAC is located and click **Next**.

Note: You cannot change the country code if the NWA/WAC products comply with the U.S. laws, policies and regulations and are to be sold to the U.S. market.

Figure 19 Wizard: Country Code

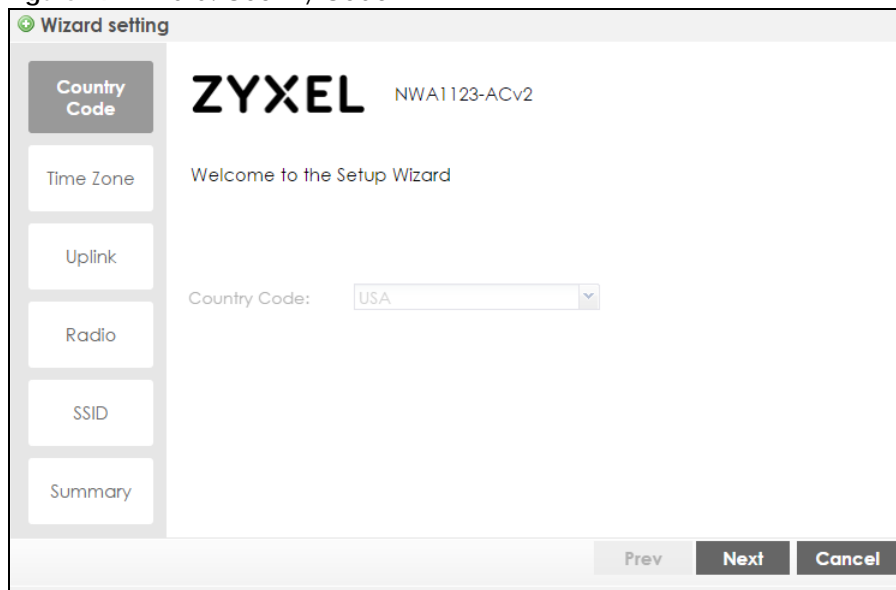

The screenshot shows the 'Wizard setting' window for a ZyXEL NWA1123-ACv2 device. On the left is a vertical sidebar with menu items: 'Country Code' (highlighted), 'Time Zone', 'Uplink', 'Radio', 'SSID', and 'Summary'. The main content area displays 'ZYXEL NWA1123-ACv2' at the top, followed by 'Welcome to the Setup Wizard'. Below this is a 'Country Code:' label and a dropdown menu currently set to 'USA'. At the bottom right of the window are three buttons: 'Prev', 'Next', and 'Cancel'.

3.2.2 Time Zone

Use this screen to configure the NWA/WAC's time zone and daylight saving time.

- **Time Zone:** Select the time zone of your location. This will set the time difference between your time zone and Greenwich Mean Time (GMT).
- **Enable Daylight Saving:** Select the option if you use Daylight Saving Time. Configure the day and time when Daylight Saving Time starts and ends.
- **Offset** allows you to specify how much the clock changes when daylight saving begins and ends. Enter a number from 1 to 5.5 (by 0.5 increments).

Click **Prev** to return to the previous screen. Click **Next** to proceed. Click **Cancel** to close the wizard without saving.

Figure 20 Wizard: Time Zone

The screenshot shows the 'Wizard setting' window for a ZyXEL NWA1123-ACv2 device. On the left is a sidebar with navigation options: Country Code, Time Zone (selected), Uplink, Radio, SSID, and Summary. The main area displays the device name 'ZYXEL' and model 'NWA1123-ACv2'. The 'Time Zone' is set to '(GMT+08:00) Beijing, Hong Kong, Perth, Singapore'. The 'Enable Daylight Saving' checkbox is checked. The 'Start Date' is configured as 'Second Sunday of March at 12:00', and the 'End Date' is 'First Sunday of November at 12:00'. The 'Offset' is set to '1 Hours'. At the bottom right are 'Prev', 'Next', and 'Cancel' buttons.

3.2.3 Uplink

Use this screen to configure the NWA/WAC's IP address.

Uplink Connection: Select **Auto (DHCP)** if the NWA/WAC is connected to a router with the DHCP server enabled. You then need to check the router for the IP address assigned to the NWA/WAC in order to access the NWA/WAC's web configurator again.

Otherwise, select **Static IP** when the NWA/WAC is NOT connected to a router or you want to assign it a fixed IP address. You will need to manually enter:

- the NWA/WAC's IP address and subnet mask.
- the IP address of the router that helps forward traffic.
- a DNS server's IP address. The Domain Name System (DNS) maps a domain name to an IP address and vice versa. The DNS server is extremely important because without it, you must know the IP address of a computer before you can access it.

Click **Prev** to return to the previous screen. Click **Next** to proceed. Click **Cancel** to close the wizard without saving.

Figure 21 Wizard: Uplink

The screenshot shows the 'Wizard setting' window for a ZyXEL NWA1123-ACv2 device. On the left is a vertical sidebar with buttons for 'Country Code', 'Time Zone', 'Uplink' (which is highlighted), 'Radio', 'SSID', and 'Summary'. The main area displays the device name 'ZYXEL' and model 'NWA1123-ACv2'. Below this, the 'Uplink Connection' is set to 'Static IP' via a dropdown menu. There are five input fields for 'IP Address', 'Subnet Mask', 'Gateway', and 'DNS Server', all of which currently contain '0.0.0.0'. At the bottom right of the window are three buttons: 'Prev', 'Next', and 'Cancel'.

3.2.4 Radio

Use this screen to configure the NWA/WAC's radio transmitter(s).

- **Channel Selection:** Select **Auto** to have the NWA/WAC automatically choose a radio channel that has least interference. Otherwise, select **Manual** and specify a channel the NWA/WAC will use in the 2.4GHz or 5GHz wireless LAN. The options vary depending on the frequency band and the country you are in.
- **Maximum Output Power:** Enter the maximum output power of the NWA/WAC. If there is a high density of APs in an area, decrease the output power of the NWA/WAC to reduce interference with other APs.

Note: Reducing the output power also reduces the NWA/WAC's effective broadcast radius.

Click **Prev** to return to the previous screen. Click **Next** to proceed. Click **Cancel** to close the wizard without saving.

Figure 22 Wizard: Radio

Wizard setting

Country Code: **ZYXEL** NWA1123-ACv2

Time Zone

Uplink

Radio

SSID

Summary

Radio 1

Band: 2.4GHz

Channel Width: 20MHz

Channel Selection: Auto Manual 6

Maximum Output Power: 30 dBm(0~30)

Radio 2

Band: 5GHz

Channel Width: 20/40/80MHz

Channel Selection: Auto Manual 36

Maximum Output Power: 20 dBm(0~30)

Prev Next Cancel

3.2.5 SSID

Use this screen to enable, disable or edit an SSID profile.

Select an SSID profile and click the **Activate** icon to turn it on or click the **Inactivate** icon to turn it off. To change an SSID profile's settings, such as the SSID (WiFi network name) and WiFi password, select the SSID profile from the list and click the **Edit** icon. See [Section 3.2.5.1 on page 50](#) for more information.

Note: You cannot add or remove an SSID profile after running the setup wizard.

Figure 23 Wizard: SSID

Wizard setting

Country Code: **ZYXEL** NWA1123-ACv2

Time Zone

Uplink

Radio

SSID

Summary

Edit Activate Inactivate

#	Status	SSID	Security Mode	Band Mo...	VLAN ID
1		Zyxel	WPA2-PSK	Dual Band	1
2		Zyxel	WPA2-PSK	Dual Band	1
3		Zyxel	WPA2-PSK	Dual Band	1
4		Zyxel	WPA2-PSK	Dual Band	1
5		Zyxel	WPA2-PSK	Dual Band	1
6		Zyxel	WPA2-PSK	Dual Band	1
7		Zyxel	WPA2-PSK	Dual Band	1
8		Zyxel	WPA2-PSK	Dual Band	1

Prev Next Cancel

3.2.5.1 Edit SSID Profile

Use this screen to configure an SSID profile.

The screen varies depending on the security type you selected.

- **SSID** - Enter a descriptive name of up to 32 printable characters for the wireless LAN.
- **VLAN ID**: Enter a VLAN ID for the NWA/WAC to use to tag traffic originating from this SSID.
- **Band Mode**: Select the wireless band which this profile should use. 2.4 GHz is the frequency used by IEEE 802.11b/g/n wireless clients. 5 GHz is the frequency used by IEEE 802.11ac/a/n wireless clients.
Not all NWA/WACs support both 2.4 GHz and 5 GHz frequency bands.
- **Security Type**: Select **WPA2** to add security on this wireless network. Otherwise, select **OPEN** to allow any wireless client to associate this network without authentication.
- **PSK (Pre-shared Key)**: If you set **Security Type** to **wpa2** and select **PSK**, enter a pre-shared key of between 8 and 63 case-sensitive ASCII characters (including spaces and symbols) or 64 hexadecimal characters.
- **802.1x**: Select **802.1x** and the **Primary / Secondary Radius Server** check box to have the NWA/WAC use the specified RADIUS server. You have to enter the IP address, port number and shared secret password of the RADIUS server to be used for authentication.

Click **OK** to proceed. Click **Cancel** to close the screen without saving.

Figure 24 Wizard: SSID: Edit (WPA2)

The screenshot shows a dialog box titled "Edit SSID Profile" with the following fields and options:

- SSID: Zyxel
- VLAN Tag
- VLAN ID: 1 (1~4094)
- Band Mode: Dual Band 2.4GHz 5GHz
- Security Type: WPA2 (dropdown menu)
- PSK
- Secret: 12345678
- 802.1X

Buttons: OK, Cancel

Figure 25 Wizard: SSID: Edit (802.1x)

Edit SSID Profile

SSID:

VLAN Tag
 VLAN ID: (1~4094)

Band Mode: Dual Band 2.4GHz 5GHz

Security Type:

PSK
 802.1X

Primary RADIUS Server
 RADIUS Server IP Address:
 RADIUS Server Port: (1~65535)
 RADIUS Server Secret:

Secondary RADIUS Server
 RADIUS Server IP Address:
 RADIUS Server Port:
 RADIUS Server Secret:

3.2.6 Summary

Use this screen to check whether what you have configured is correct. Click **Save** to apply your settings and complete the wizard setup. Otherwise, click **Prev** to return to the previous screen or click **Cancel** to close the wizard without saving.

Figure 26 Wizard: Summary

Wizard setting

Country Code: **ZYXEL** NWA1123-ACv2

Country Code: USA
 Time Zone: (GMT+08:00) Beijing, Hong Kong, Perth, Singapore, Taipei
 Daylight Saving: Enable
 Management IP: DHCP
 2.4G Radio: DCS
 5G Radio: DCS
 SSID:

#	Status	SSID	Security Mode	Band Mo...	VLAN ID
1	🔴	Zyxel	WPA2-PSK	Dual Band	1
2	🔴	Zyxel	WPA2-PSK	Dual Band	1
3	🔴	Zyxel	WPA2-PSK	Dual Band	1
4	🔴	Zyxel	WPA2-PSK	Dual Band	1