

# EMC TEST REPORT

**Report No. : TS09050111-EME**

**Model No. : MAX-206M1R**

**Issued Date : Jul. 02, 2009**

**Applicant: ZyXEL Communications Corporation**  
**6, Innovation Rd II, Science-Based Industrial Park,**  
**Hsin-Chu, Taiwan**

**Test Method/ Standard: 47 CFR FCC Part 2 and Part 27, Subpart C**

**Test By: Intertek Testing Services Taiwan Ltd.**  
**No. 11, Lane 275, Ko-Nan 1 Street, Chia-Tung Li,**  
**Shiang-Shan District, Hsinchu City, Taiwan**

It may be duplicated completely for legal use with the allowance of the applicant. It shall not be reproduced except in full, without the written approval of Intertek Laboratory. The test result(s) in this report only applies to the tested sample(s).

**The test report was prepared by:** Sign on File  
Sunny Liu/ Sr. Officer

**These measurements were taken by:** Sign on File  
Arthur Tsai/ Engineer

**The test report was reviewed by:**

**Name** Eric Chu  
**Title** Technical Manager

## Table of Contents

- 1. Summary of Test Data ..... 4
- 2. General Information ..... 5
- 3. Test Equipment List..... 9
- 4. RF Power Output..... 11
  - 4.1 Conducted Power Measurement ..... 11
    - 4.1.2 LIMITS OF RF Power Output..... 11
    - 4.1.3 Method of Measurement..... 11
    - 4.1.4 Test Diagram..... 11
    - 4.1.5 Test Result..... 12
  - 4.2 Radiated Power Measurement..... 13
- 5. Occupied Bandwidth ..... 15
  - 5.1 LIMITS OF Occupied Bandwidth Measurement..... 15
  - 5.2 Method of Measurement ..... 15
  - 5.3 Test Diagram ..... 15
  - 5.4 Test Result..... 16
- 6. Spurious Emissions at Antenna Terminals..... 20
  - 6.1 LIMITS OF Spurious Emissions at Antenna Terminals Measurement..... 20
  - 6.2 Method of Measurement ..... 20
  - 6.3 Test Diagram ..... 20
  - 6.4 Test Result..... 21
- 7. Field Strength of Spurious Radiation ..... 35
  - 7.1 LIMITS OF Field Strength of Spurious Radiation MEASUREMENT ..... 35
  - 7.2 Test Procedure and Setup ..... 35
  - 7.3 Method of Measurement ..... 35
    - 7.3.1 Spurious Radiated Emission ..... 35
    - 7.3.2 Radiated Field Strength ..... 36
  - 7.4 Test Diagram ..... 36
    - 7.4.1 Spurious Radiated Emission ..... 36
    - 7.4.2 Radiated Field Strength ..... 37
  - 7.5 Field Strength of Spurious Radiation Emission Limit..... 37
    - 7.5.1 Spurious Radiated Emission ..... 37
    - 7.5.2 Radiated Field Strength ..... 37
  - 7.6 Test Result..... 38
- 8. AC power line conducted emission..... 45
  - 8.1 Method of Measurement ..... 45
  - 8.2 Test Diagram ..... 45
  - 8.3 Emission Limit..... 46
  - 8.4 Test Result..... 47

9. Frequency Stability ..... 49  
    9.1 Method of Measurement ..... 49  
    9.2 Test Result..... 50  
Attachment 1: PHY Profile ..... 52  
Attachment 2: Power Class Profile..... 55

## 1. Summary of Test Data

<b>Test/Requirement Description</b>	<b>Applicable Rule</b>	<b>Result</b>
RF Power Output	CFR 47, Part 2, Para 2.1046 CFR 47, Part 27, Para 27.50(h)(2)	Pass
Occupied Bandwidth	CFR 47, Part 2, Para 2.1049 CFR 47, Part 27, Para 27.53(m)(6)	Pass
Spurious Emission at Antenna Terminals	CFR 47, Part 2, Para 2.1051 CFR 47, Part 27, Para 27.53(m)(2)(v)(6)	Pass
Field Strength of Spurious Radiation	CFR 47, Part 2, Para 2.1053 CFR 47, Part 15.209 CFR 47, Part 27, Para 27.53(m)(2)(v)(6)	Pass
AC Power Line Conducted Emission	CFR 47, Part 15.207	Pass
Frequency Stability	CFR 47, Part 2, Para 2.1055 CFR 47, Part 27, Para 27.54	Pass

## 2. General Information

### Identification of the EUT

Product	WiMAX MIMO CPE
Model No.	MAX-206M1R
FCC ID.	I88MAX206M1R
Frequency Range	2500MHz to 2690MHz
Type(s) of Modulation	QPSK, 16QAM
Emission Designator	For 5MHz: 4M63D2D For 10MHz:9M15D2D
RF Power Output	32.60 dBm at antenna terminals
Rated Power	100-240Vac, 50/60Hz with adapter (Model No.: DSA-30WN-12 US 120240)
Power Cord	N/A
Sample Received	May 18, 2009
Test Date(s)	May 18, 2009 ~ Jun. 30, 2009

Note 1: This report is for the exclusive use of Intertek's Client and is provided pursuant to the agreement between Intertek and its Client. Intertek's responsibility and liability are limited to the terms and conditions of the agreement. Intertek assumes no liability to any party, other than to the Client in accordance with the agreement, for any loss, expense or damage occasioned by the use of this report. Only the Client is authorized to permit copying or distribution of this report and then only in its entirety. Any use of the Intertek name or one of its marks for the sale or advertisement of the tested material, product or service must first be approved in writing by Intertek. The observations and test results in this report are relevant only to the sample tested. This report by itself does not imply that the material, product, or service is or has ever been under an Intertek certification program.

Note 2: When determining the test conclusion, the Measurement Uncertainty of test has been considered.

**EUT RF Profile of WiMax forum:**

1. RF Profile:

Frequency Range (GHz)	Channel Frequency Step (kHz)	Channel Bandwidth(s)(MHz)	FFT size	Duplexing Mode
2.496 – 2.690	250	5	512	TDD
		10	1024	TDD

The RF profile of EUT is followed WiMax forum Document “ WiMAX Forum™ Mobile System Profile Release 1.0 Approved Specification”, The EUT is WiMAX device which used TDD mode. Following clause 4.1.1.2 table 6 of attachment 1, the EUT is compliant to not only frequency band (2496~2690MHz) of WiMAX Forum specification, but also lowest bandedge and highest bandedge of FCC Part 27 requirement.

2. PHY Parameter:

Parameter	Uplink	Uplink
System Bandwidth	5MHz	10MHz
FFT Size	512	1024
Null Sub-Carriers	104	184
Pilot Sub-Carriers	136	280
Data Sub-Carriers	272	560
Sub-Channels	17	35
Symbol Period, Ts	102.9 microseconds	
Frame Duration	5 millisecond	
OFDM Symbols/Frame	48	
Data OFDM Symbols	44	
Modulations	QPSK 1/2 CTC , QPSK 3/4 CTC 16QAM 1/2 CTC , 16QAM 3/4 CTC (The EUT is followed WiMAX forum document“ WiMAX Forum™ Mobile System Profile Release 1.0 Approved Specification” as attachment 2, clause 7, and Table 131.)	

3. Voltage and current through final PA

According to 2.1033 (c) (8), the voltage is 157mV, and the current is 878mA

4. According to 2.1033 (c) (6), the range of operating power values are ±1dB, please also reference specification of manual.

## Description of EUT

The EUT is a WiMAX IEEE802.16e Indoor Simple CPE-2.5GHz and was defined as temporary fixed station, it has two type of Bandwidth, one is 5MHz, the other is 10MHz and was defined as information technology equipment.

For more detail features, please refer to User's manual as file name "Installation guide.pdf"

The EUT used Runcom's chips for WiMAX solution.  
All test have been done in accordance with the WiMAX standard IEEE 802.16e-2005. and with compliance to the MRCT requirements.  
(Ref. Runcom Technologies Ltd MSS Test results)

## Antenna description

The antenna is affixed to the EUT using a unique connector, which allows for replacement of a broken antenna, but DOES NOT use a standard antenna jack or electrical connector.

Antenna Gain : 6dBi max  
Antenna Type : Omni antenna  
Connector Type : I-PAX

**Test description**

Since the EUT has 16QAM and QPSK modulation, after verifying both modulations, the maximum output power and the worst case were found at OFDMA QPSK 1/2 for 5 MHz Bandwidth and 10 MHz Bandwidth. The final tests has been executed under these conditions and recorded in this report individually.

The EUT was transmitted continuously during the test and subchannelizations as below (for 5MHz. &10MHz Bandwidth)

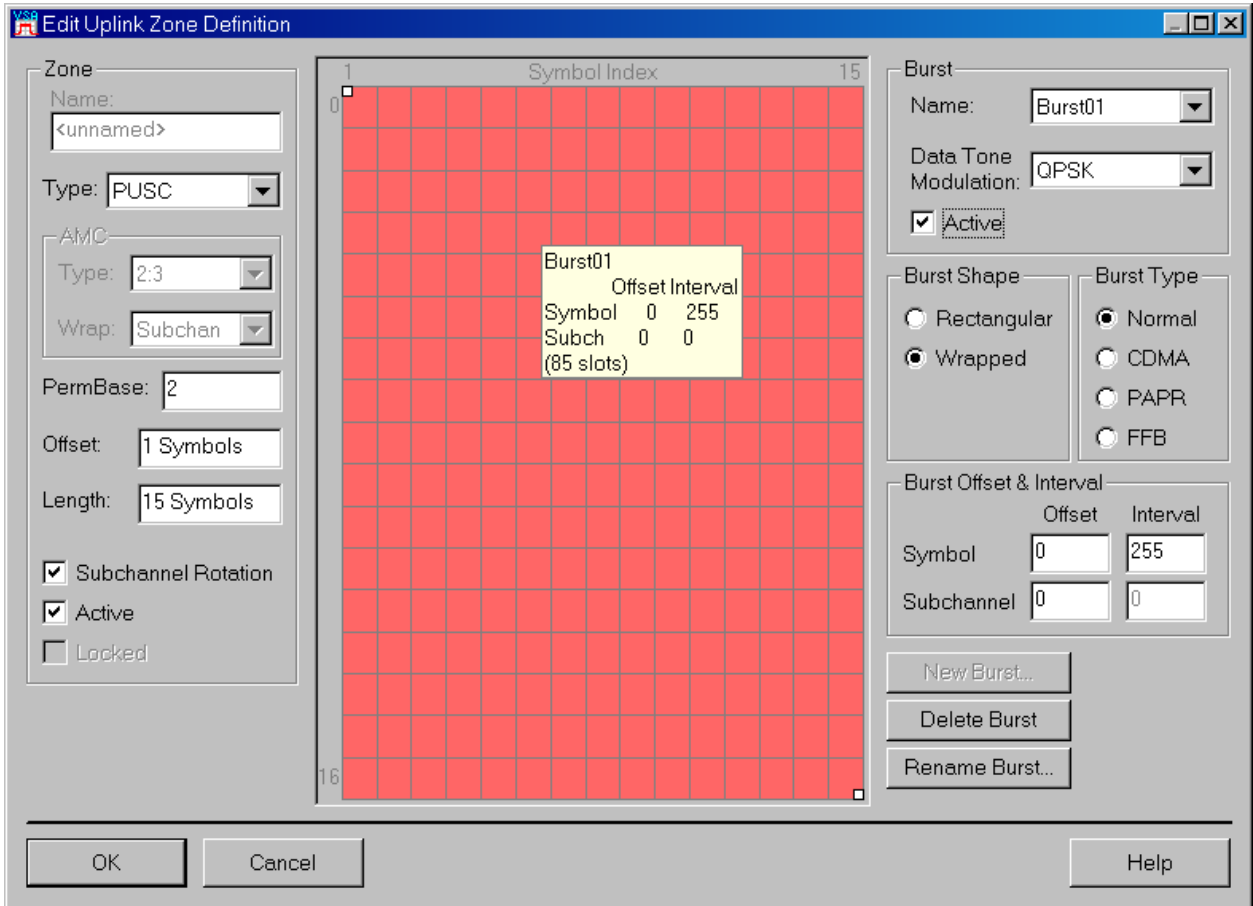



### 3. Test Equipment List

Intertek ID No.	Equipment	Brand	Model No.
EC1332	Horn Antenna	EMCO	3115
EC1348	X-WING Bilog Antenna	CHASE	CBL 6141
EC1352	Pre-Amplifier(1-20G)	AML	AML0120L3401
EC1354	Signal Generator	Rohde&schwarz	SMR27
EC1355-2	Pre-Amplifier(9k-3G)	Advantest	BB525C
EC1360	Microwave Amplifier	Agilent	8348A
EC1398	FSP30 Spectrum Analyzer	Rohde &	FSP30
EC1303	EMI Test Receiver	Rohde&schwarz	ESCS30
EC1320	Two-Line -V-Network	Rohde&schwarz	ESH3-Z5
EC1384	Artificial Mains Network (LISN)	Schaffner	MN2050D
EC1401	EMI current probe	Schaffner	Solar 9208-1c
EC1405	Impedanz-stabilisierungs-Netzwerk	TESEQ	ISN T8
EC1406	PLC ISN (150K-30MHz)	FCC	FCC-TLISN-T2_P
EC1363	Temperature&Humidity Test Chamber	TERCHY	MHU-225LRU(SA)
EC1365	Spectrum Analyzer	Rohde&schwarz	FSEK30
EC1396	Power Meter	Anritsu	ML2487A
EC1396-1	Power Sensor	Anritsu	MA2491A
EC1399	Spectrum Analyzer	Anritsu	MS2687B
EC1404-1	WiMAX PSA Spectrum Analyzer 3Hz-26.5GHz	Agilent	E4440A
EC1404-2	WiMAX ESG Vector Signal Generator 250kHz-6.0GHz	Agilent	E4438C
EC1404-3	WiMAX ESG Vector Signal Generator 250kHz-6.0GHz	Agilent	E4438C
EC1404-4	WiMAX Power Meter	Agilent	N1911A
EC1404-5	WiMAX Wideband Power Sensor	Agilent	N1921A
EC1411	Power Meter	Anritsu	ML5495A
EC1411-1	Power Sensor	Anritsu	MA2411B

Note: 1. The above equipments are within the valid calibration period.



**Measurement Uncertainty:**

Measurement uncertainty was calculated in accordance with NAMAS NIS 81.

Parameter	Uncertainty
Radiated Emission	±4.98 dB
Conducted Emission	±2.6 dB

This uncertainty represents an expanded uncertainty expressed at approximately the 95% confidence level using a coverage factor of k=2.

## 4. RF Power Output

### 4.1 Conducted Power Measurement

<b>Base Standard</b>	FCC 2.1046 & 27.50(h)
----------------------	-----------------------

**Test Result:** Complies

**Test Equipment:** EC1396

#### 4.1.2 LIMITS OF RF Power Output

The radiated peak output power shall be according to the specific rule Part 27.50(h)(2) that “Other User stations are limited to 2 watts and 27.50(i) specific that “Peak transmit power must be measure over any interval of continuous transmission using instrumentation calibration in terms of rms-equivalent voltage.”

#### 4.1.3 Method of Measurement

The peak power at antenna terminals is measured using a Power Meter. Power output is measured with the maximum rated input level.

#### 4.1.4 Test Diagram

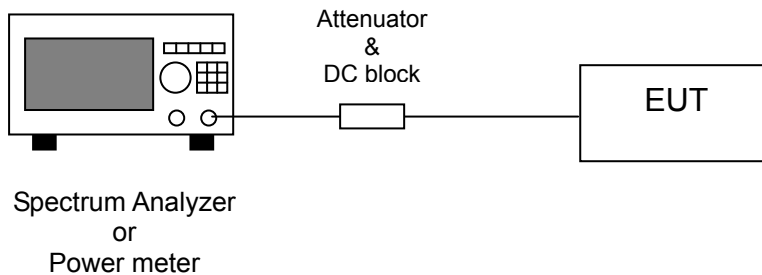

#### 4.1.5 Test Result

##### For 5 MHz

Modulation(Coding rate)	Frequency (MHz)	Reading	Cable loss	Antenna Gain	Calculated Power	Limit
		(dBm)	(dB)	(dBi)	(dBm)	(dBm)
QPSK(1/2)	2502.5	24.85	1.5	6	32.35	33
	2590	25.00	1.5	6	32.50	33
	2687.5	25.02	1.5	6	32.52	33
QPSK(3/4)	2502.5	25.01	1.5	6	32.51	33
	2590	24.83	1.5	6	32.33	33
	2687.5	25.06	1.5	6	32.56	33
16QAM(1/2)	2502.5	24.54	1.5	6	32.04	33
	2590	24.60	1.5	6	32.10	33
	2687.5	24.78	1.5	6	32.28	33
16QAM(3/4)	2502.5	25.10	1.5	6	32.60	33
	2590	24.80	1.5	6	32.30	33
	2687.5	24.86	1.5	6	32.36	33

##### For 10 MHz

Modulation(Coding rate)	Frequency (MHz)	Reading	Cable loss	Antenna Gain	Calculated Power	Limit
		(dBm)	(dB)	(dBi)	(dBm)	(dBm)
QPSK(1/2)	2505	24.73	1.5	6	32.23	33
	2590	24.88	1.5	6	32.38	33
	2685	24.65	1.5	6	32.15	33
QPSK(3/4)	2505	24.67	1.5	6	32.17	33
	2590	24.84	1.5	6	32.34	33
	2685	24.72	1.5	6	32.22	33
16QAM(1/2)	2505	24.67	1.5	6	32.17	33
	2590	24.67	1.5	6	32.17	33
	2685	24.53	1.5	6	32.03	33
16QAM(3/4)	2505	24.79	1.5	6	32.29	33
	2590	24.94	1.5	6	32.44	33
	2685	24.77	1.5	6	32.27	33

## 4.2 Radiated Power Measurement

<b>Name of Test</b>	EIRP Power
<b>Base Standard</b>	FCC 2.1046 & 27.50(h)

**Test Equipment:** EC1353

### 4.2.1 Method of Measurement

Tests were performed to identify the maximum equivalent isotropically radiated output power from the EUT.

The EIRP was measured with the EUT arranged on a non-conducting table on a fully-anechoic chamber,

The test procedure is consist of three parts:

1. Measured the highest peak readings in horizontal & vertical polarity in the three orthogonal axes.
2. Use the substitution method to perform final tests.
  - I. The EUT was substituted with a half wave dipole.
  - II. The substituted antenna was set to the same center location as the EUT in horizontal or vertical polarity.
  - III. The substituted antenna was connected with a 6dB attenuator for impedance matching purpose between S/G and substituted antenna.
  - IV. The S/G was tuned to the frequency according to the measurement results and used a broadband S/G to generate the signal.
  - V. The level of S/G was adjusted until the maximum reading is the same as recorded EUT level. (A power amplifier maybe used to produce the wanted power)
3. The EIRP was calculated as:

$$\text{EIRP} = \text{S/G level} - \text{cable loss} + \text{antenna gain}$$

The maximum EIRP test results are recorded in the following table

### 4.2.3 Test Result

#### For 5 MHz

Modulation(Coding rate)	Frequency (MHz)	Imcompensation	Cable loss	Reading (EIRP)	Limit
		(dBm)	(dB)	(dBm)	(dBm)
QPSK(1/2)	2502.5	20.776	9.784	30.56	33
	2590	22.726	9.784	32.51	33
	2687.5	22.196	9.784	31.98	33
QPSK(3/4)	2502.5	20.446	9.784	30.23	33
	2590	23.026	9.784	32.81	33
	2687.5	21.846	9.784	31.63	33
16QAM(1/2)	2502.5	20.986	9.784	30.77	33
	2590	22.746	9.784	32.53	33
	2687.5	22.076	9.784	31.86	33
16QAM(3/4)	2502.5	20.586	9.784	30.37	33
	2590	22.496	9.784	32.28	33
	2687.5	21.526	9.784	31.31	33

#### For 10 MHz

Modulation(Coding rate)	Frequency (MHz)	Imcompensation	Cable loss	Reading (EIRP)	Limit
		(dBm)	(dB)	(dBm)	(dBm)
QPSK(1/2)	2505	20.536	9.784	30.32	33
	2590	22.766	9.784	32.55	33
	2685	22.006	9.784	31.79	33
QPSK(3/4)	2505	21.046	9.784	30.83	33
	2590	22.516	9.784	32.30	33
	2685	21.726	9.784	31.51	33
16QAM(1/2)	2505	20.576	9.784	30.36	33
	2590	22.926	9.784	32.71	33
	2685	22.056	9.784	31.84	33
16QAM(3/4)	2505	21.056	9.784	30.84	33
	2590	22.596	9.784	32.38	33
	2685	22.186	9.784	31.97	33

## 5. Occupied Bandwidth

<b>Base Standard</b>	FCC 27.53(m)(6)
----------------------	-----------------

**Test Equipment:** EC1365

### 5.1 LIMITS OF Occupied Bandwidth Measurement

According to FCC 27.53(m)(6) specified that emission bandwidth is defined as the width of the signal between two points, one below the carrier center frequency and one above the carrier center frequency, outside of which all emissions are attenuated at least 26dB below the transmitter power.

### 5.2 Method of Measurement

A portion of the transmitted signal is coupled to a Spectrum Analyzer with a resolution bandwidth of at least 1% of the bandwidth of the transmitted signal. The resolution bandwidth is chosen so as not to reduce the peak level of the measured waveform. The appropriate bandwidth mask is applied to the output waveform to verify compliance.

### 5.3 Test Diagram

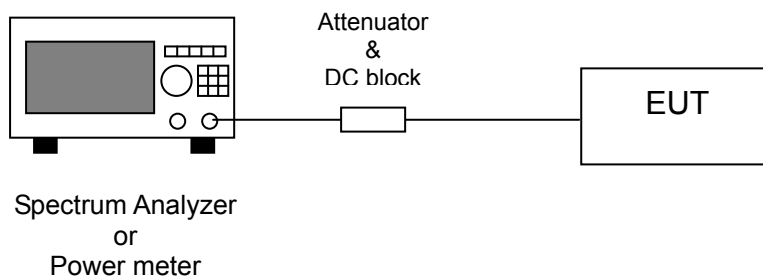

## 5.4 Test Result

**Note:** The EUT was tested while in a continuous transmit mode.

Frequency (MHz)	Bandwidth (MHz)
2502.5	4.6342
2590.0	4.6029
2687.5	4.5699
2505	9.1455
2590	9.1315
2685	9.1292



Occupied Bandwidth @ low channel (5MHz)

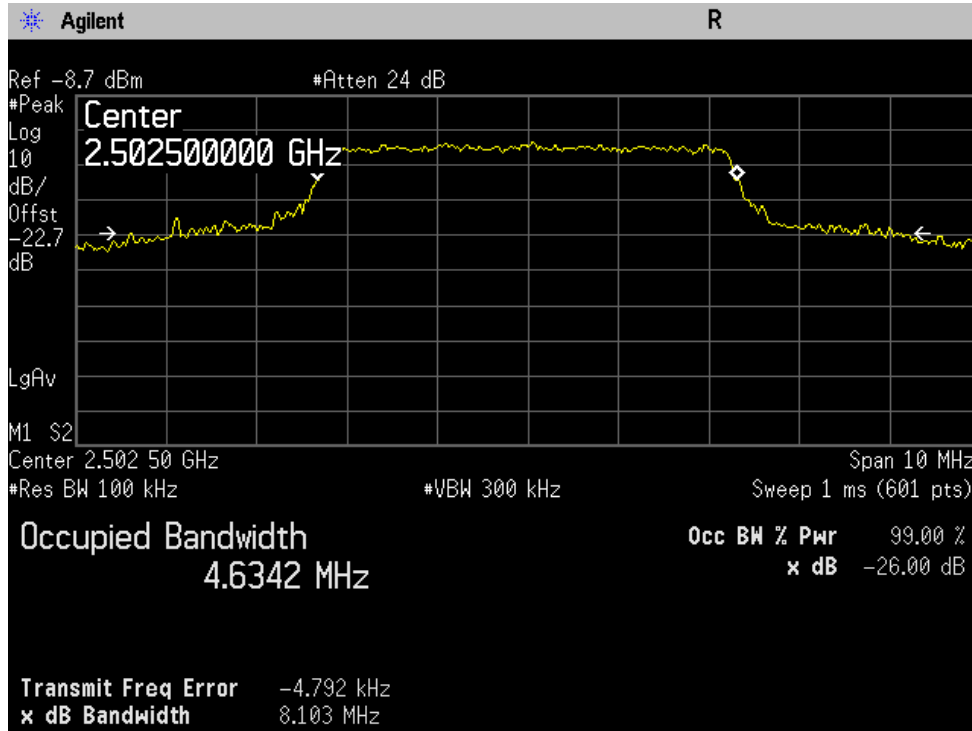

Occupied Bandwidth @ middle channel (5MHz)

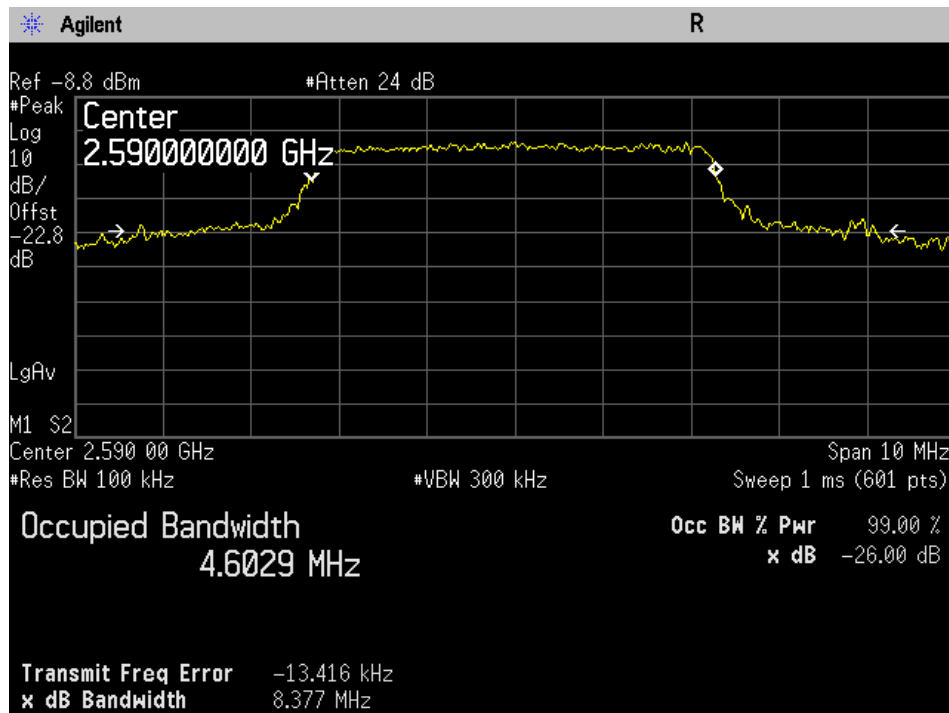

Occupied Bandwidth @ high channel (5MHz)

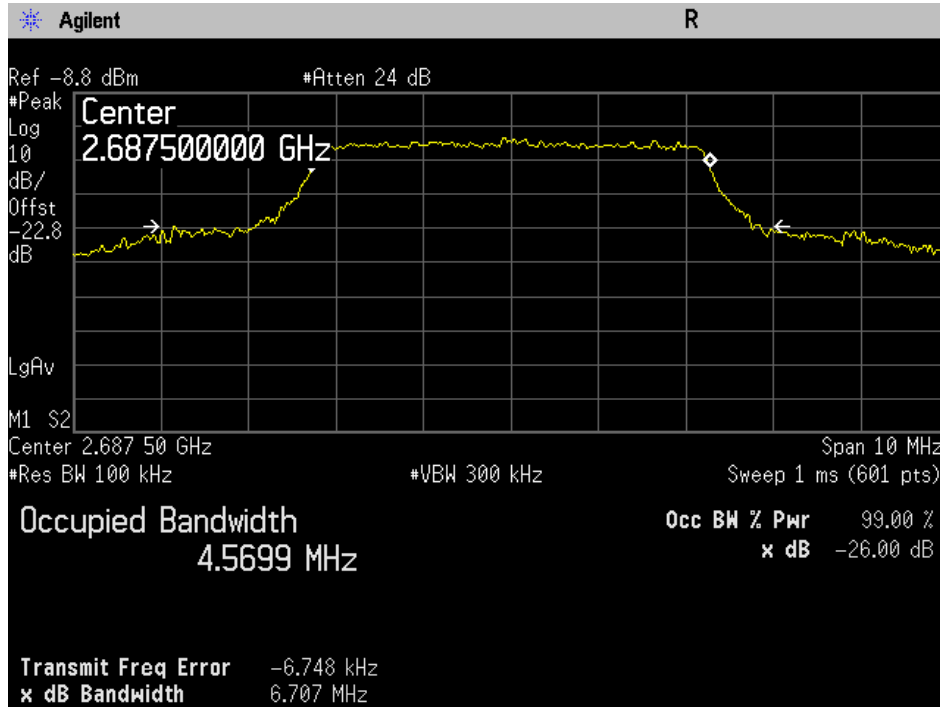

Occupied Bandwidth @ low channel (10MHz)

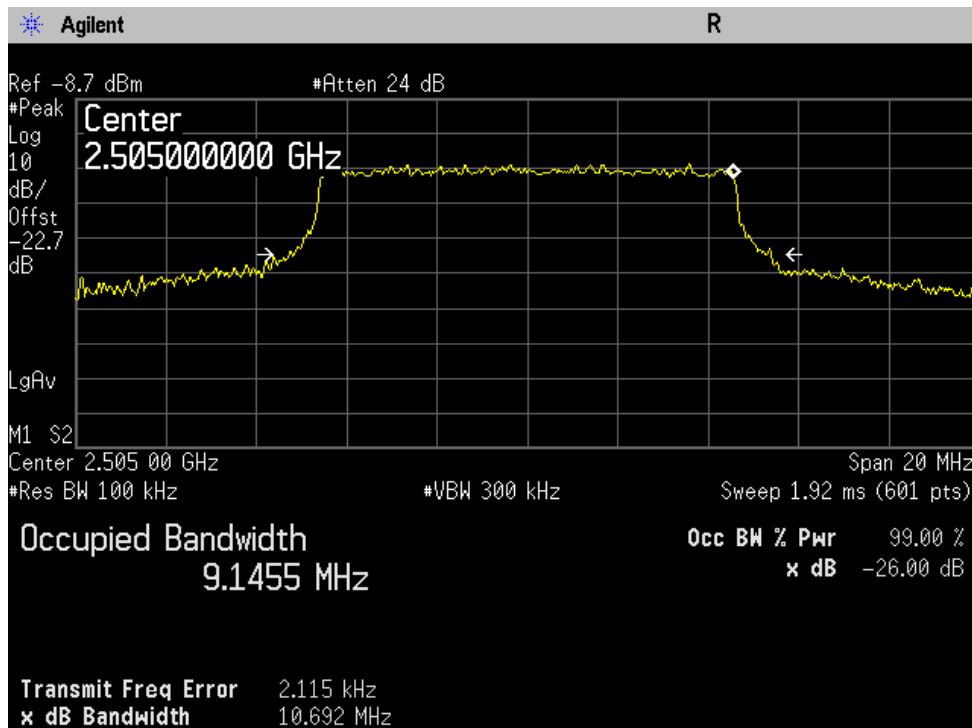

Occupied Bandwidth @ middle channel (10MHz)

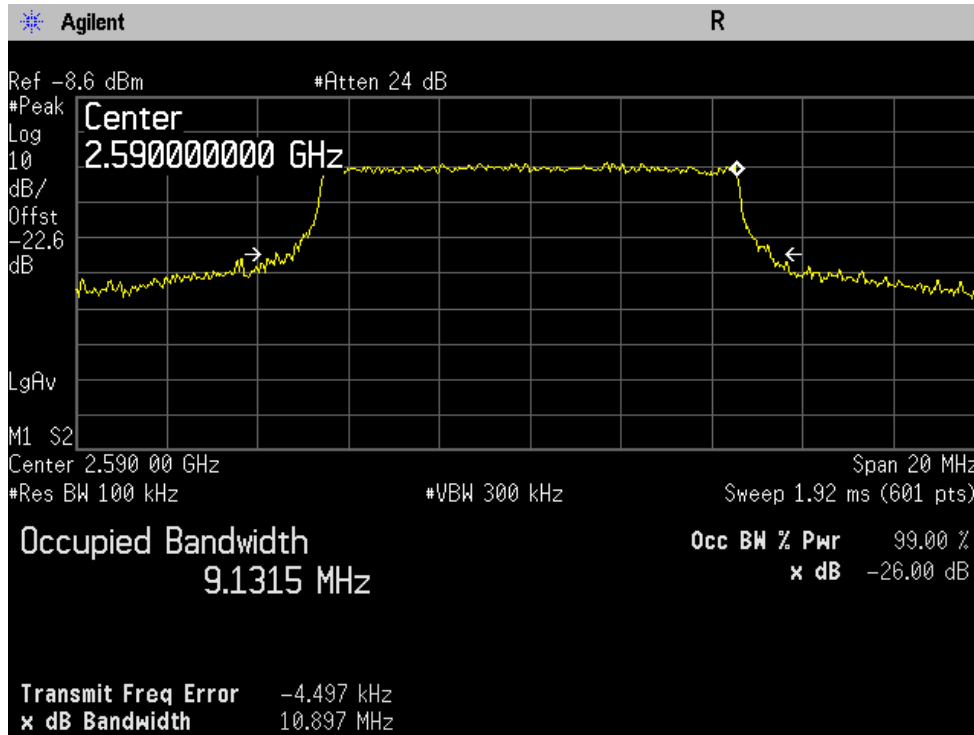

Occupied Bandwidth @ high channel (10MHz)

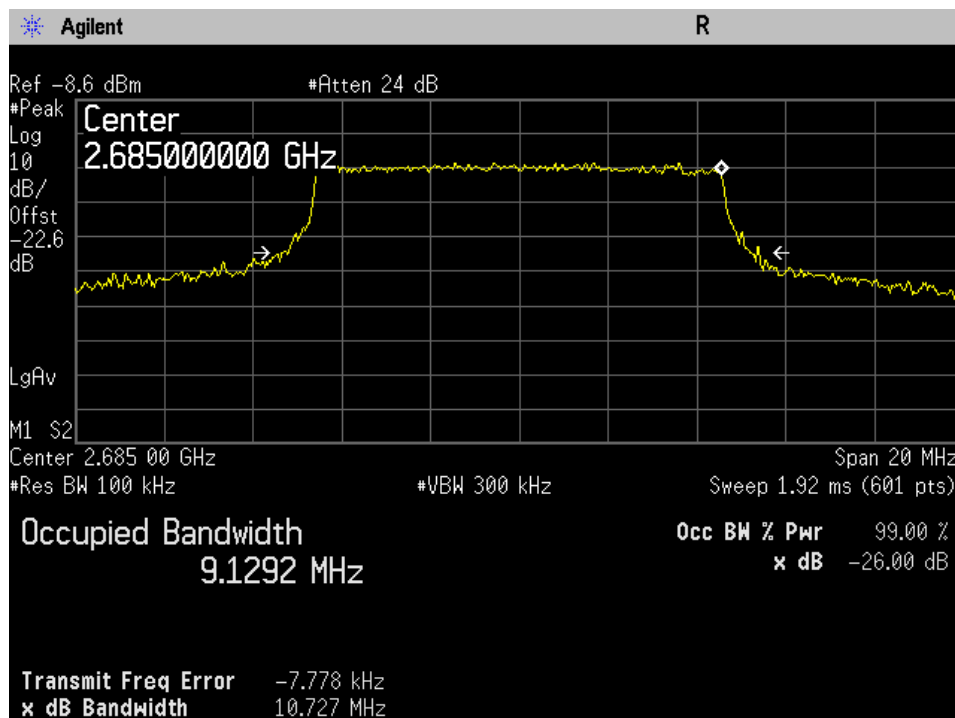

## 6. Spurious Emissions at Antenna Terminals

Base Standard	FCC 27.53(m)(2)(v)
---------------	--------------------

Test Equipment: EC1365

### 6.1 LIMITS OF Spurious Emissions at Antenna Terminals Measurement

In the FCC 27.53(m)(2)(v), On any frequency outside a licensee’s frequency block, For all fixed digital user stations, the attenuation factor shall be not less than  $43 + 10 \log (P)$  dB at the channel edge.

### 6.2 Method of Measurement

A portion of the transmitted signal is coupled to a Spectrum Analyzer with a resolution bandwidth of 1 MHz for emissions above 1 GHz. Below 1 GHz the resolution bandwidth is chosen so as not to reduce the peak level of the measured waveform. The appropriate limit line is applied to the output waveform to verify compliance.

### 6.3 Test Diagram

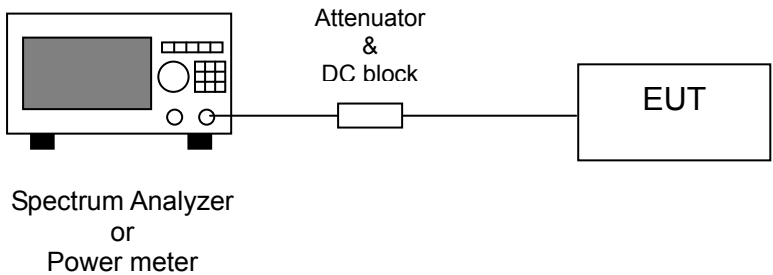

- Note:**
- (1) The EUT was tested while in a continuous transmit mode. The EUT was tuned to a low, middle and high channel.
  - (2) The EUT operating at 2.5GHz band. Frequency Range scanned from 30MHz to 27GHz.

**6.4 Test Result**

**Lower Band Edge (5MHz)**

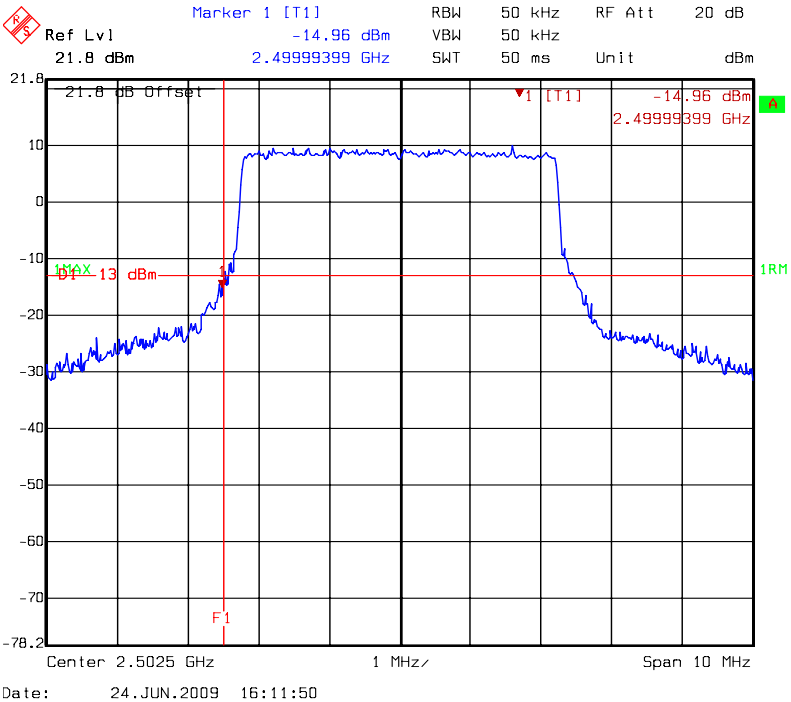

**Upper Band Edge (5MHz)**

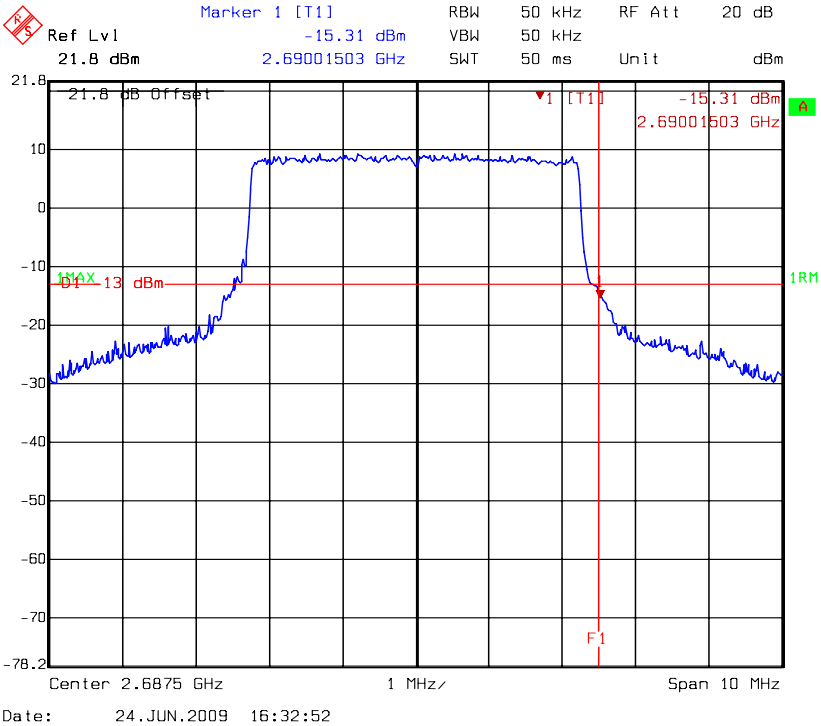

**Lower Band Edge (10MHz)**

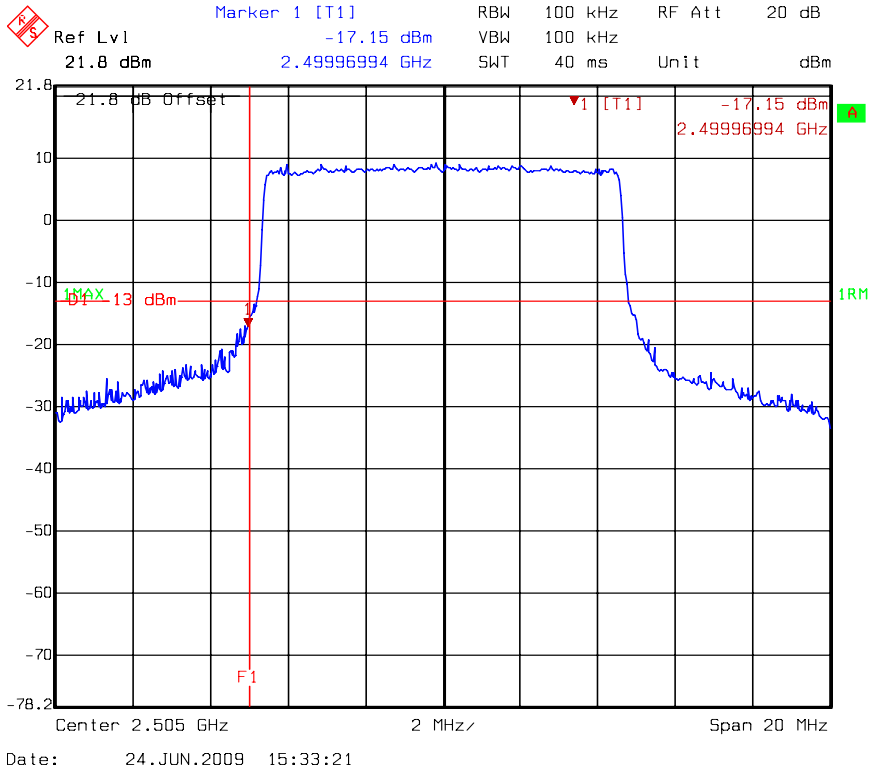

**Upper Band Edge (10MHz)**

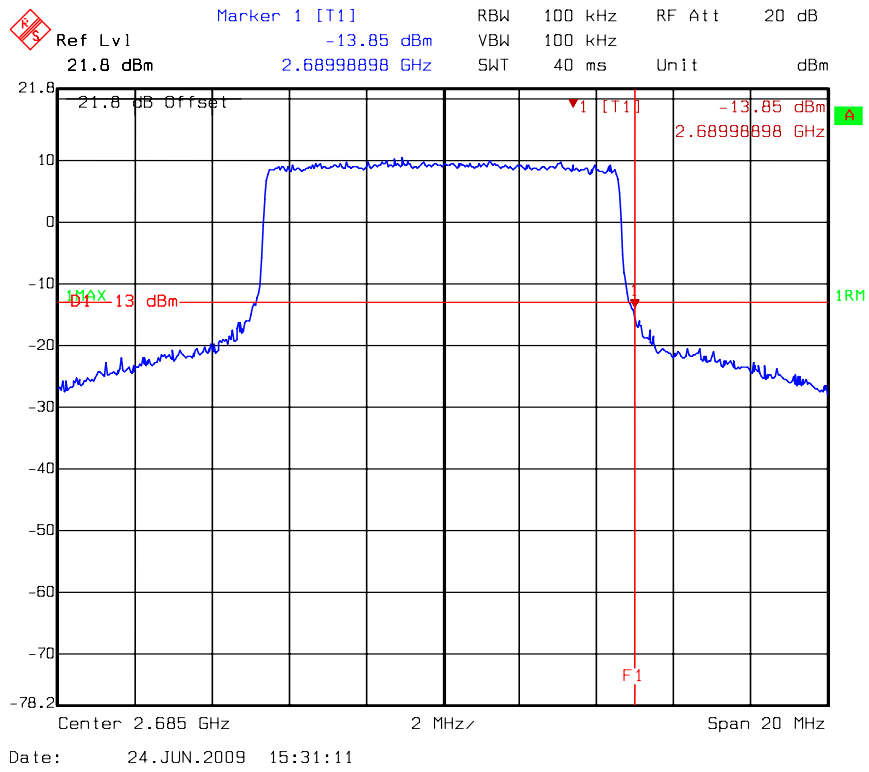

Spurious Emission at Antenna Terminals @ low channel (5MHz) - 1 of 4

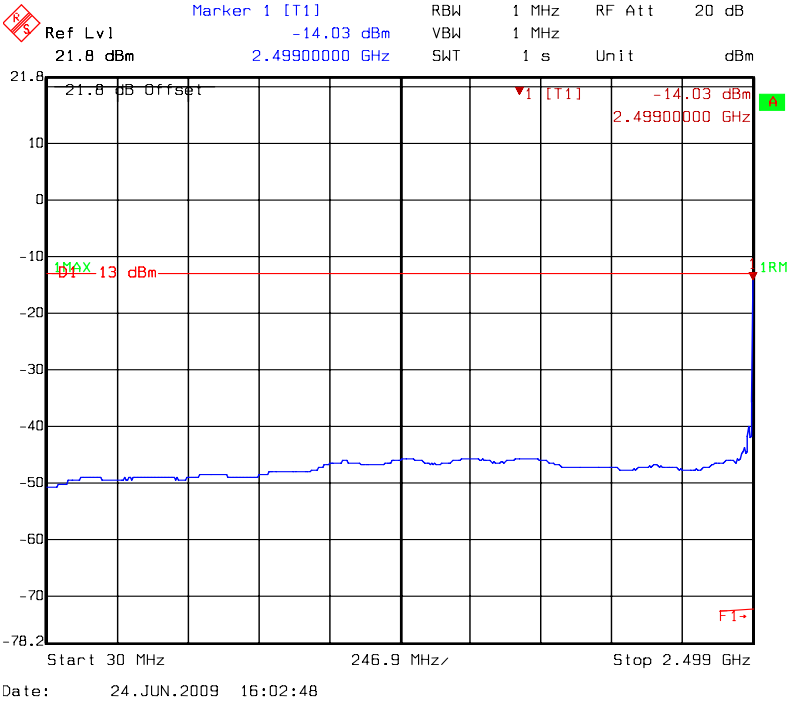

Spurious Emission at Antenna Terminals @ low channel (5MHz) - 2 of 4

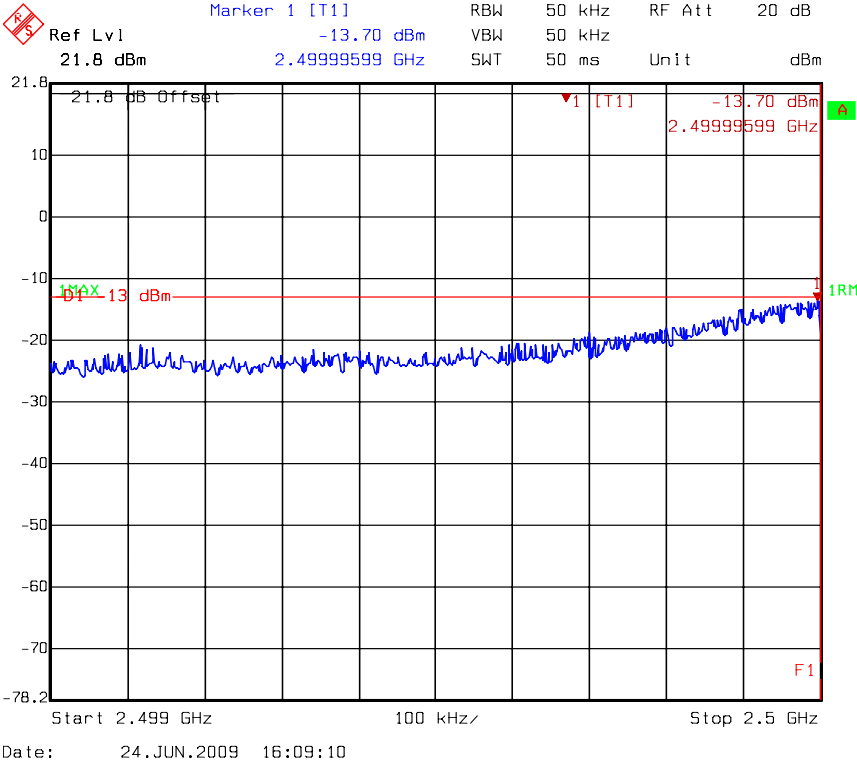

Spurious Emission at Antenna Terminals @ low channel (5MHz) - 3 of 4

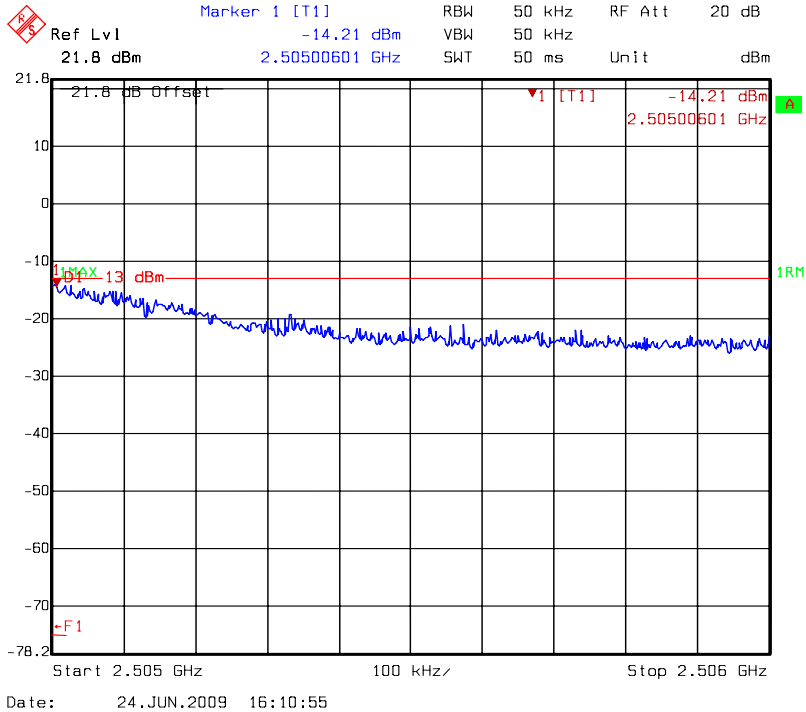

Spurious Emission at Antenna Terminals @ low channel (5MHz) - 4 of 4

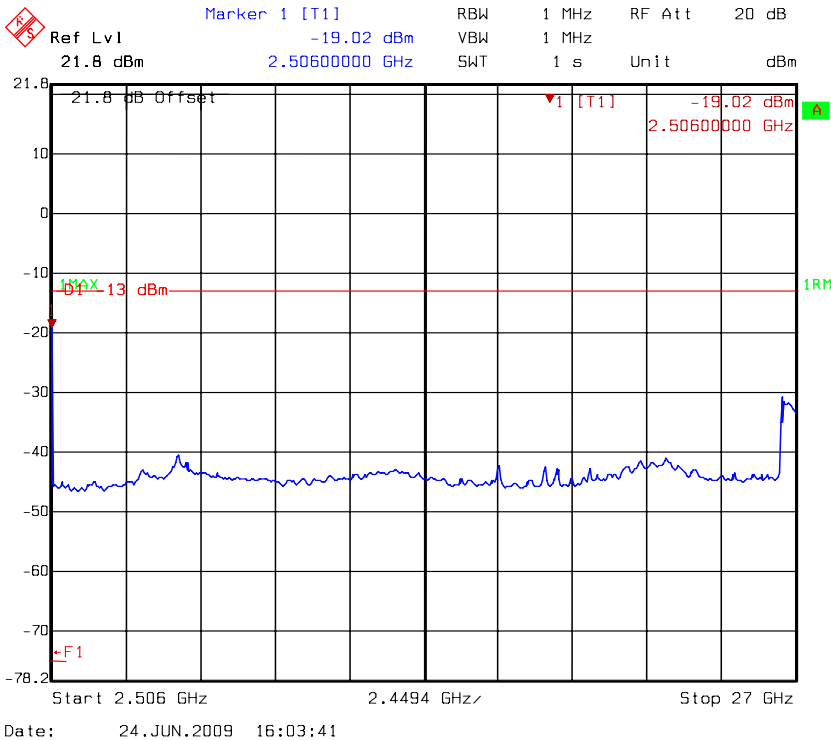



Spurious Emission at Antenna Terminals @ middle channel (5MHz) - 1 of 4

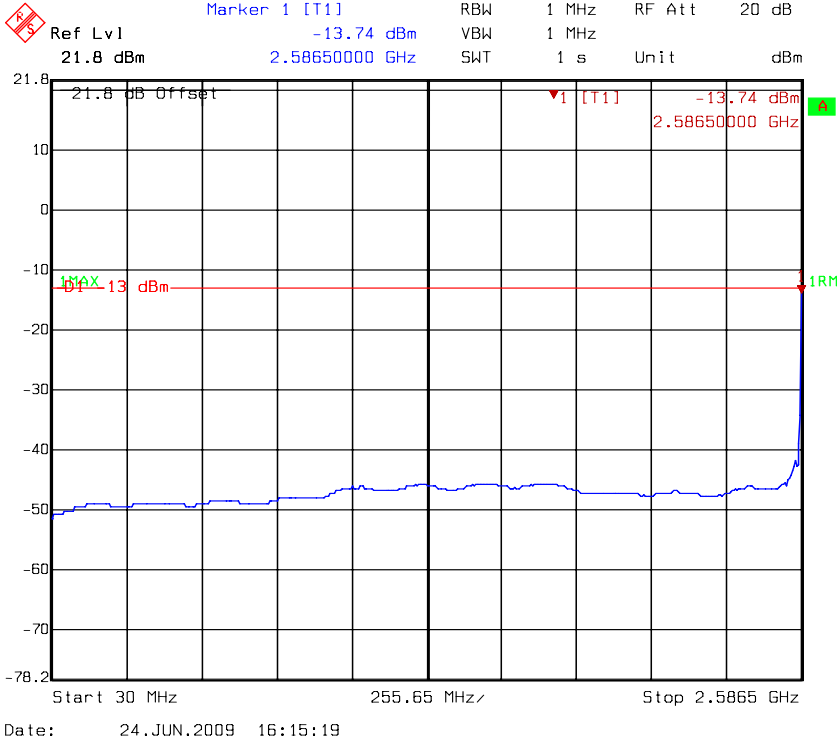

Spurious Emission at Antenna Terminals @ middle channel (5MHz) - 2 of 4

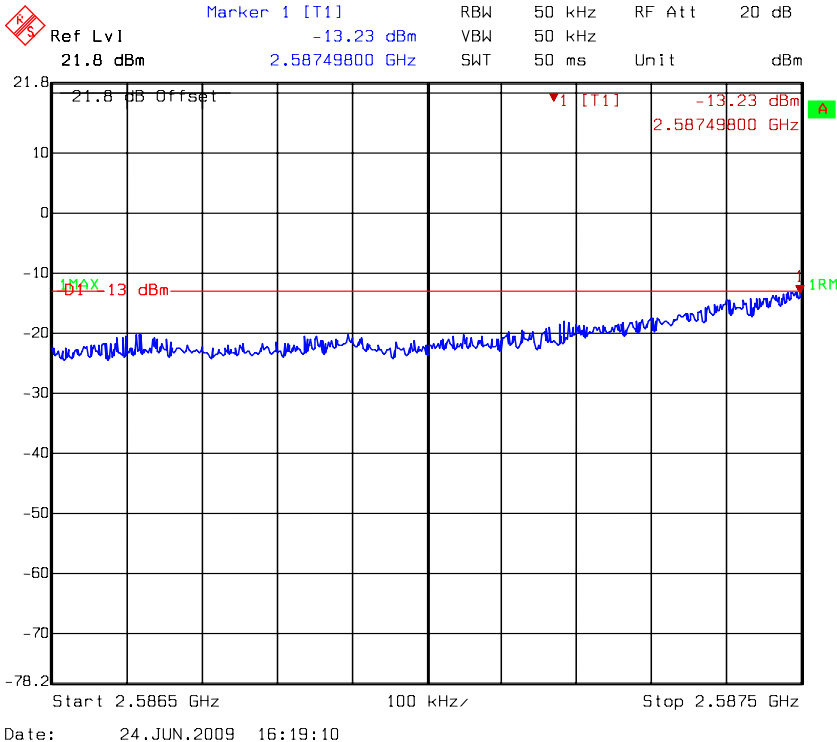

Spurious Emission at Antenna Terminals @ middle channel (5MHz) - 3 of 4

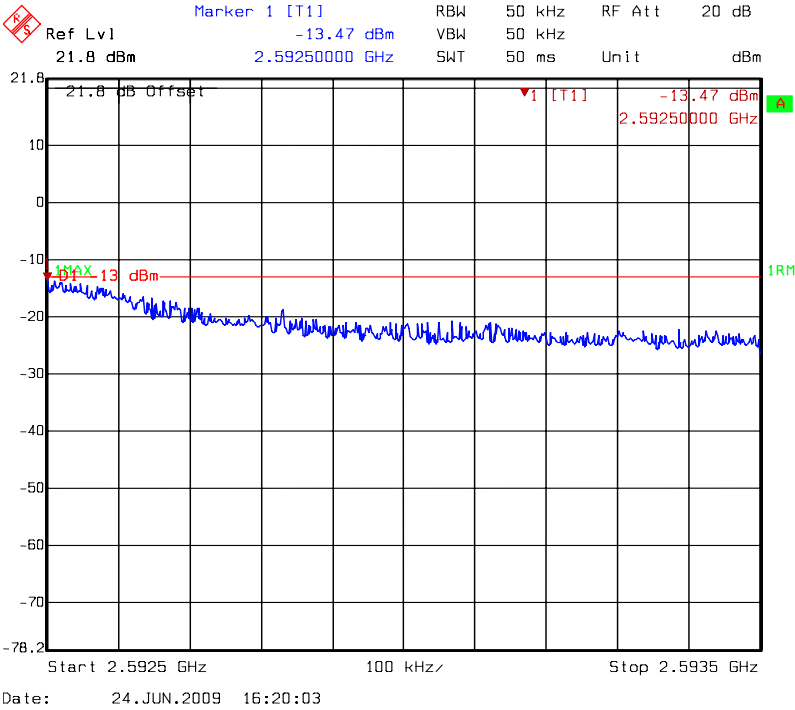

Spurious Emission at Antenna Terminals @ middle channel (5MHz) - 4 of 4

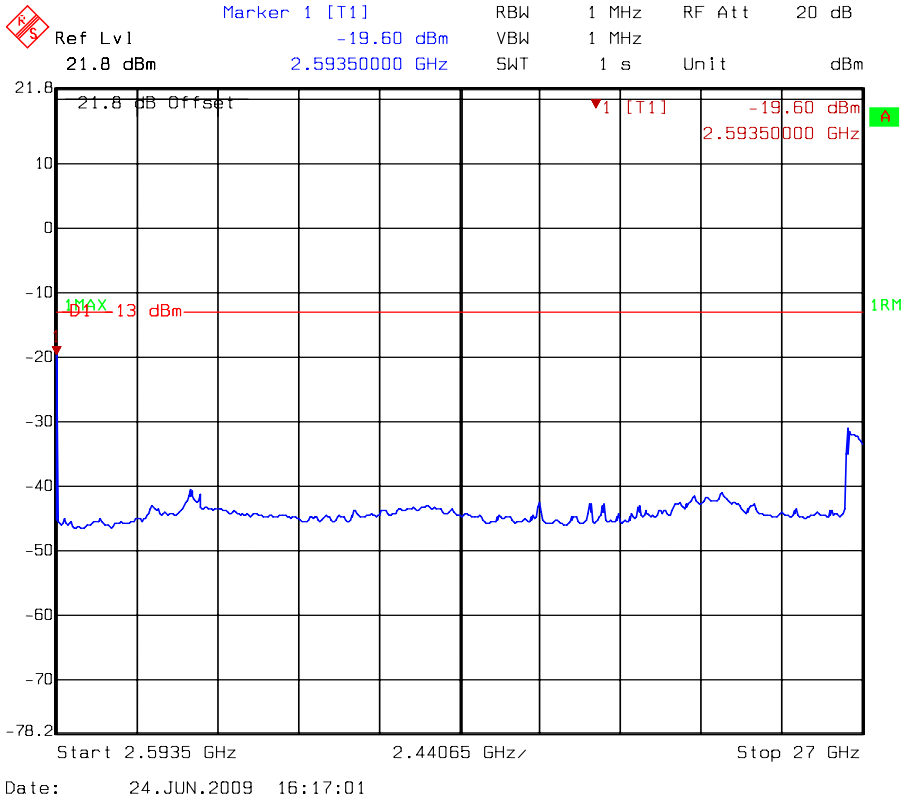

Spurious Emission at Antenna Terminals @ high channel (5MHz) - 1 of 4

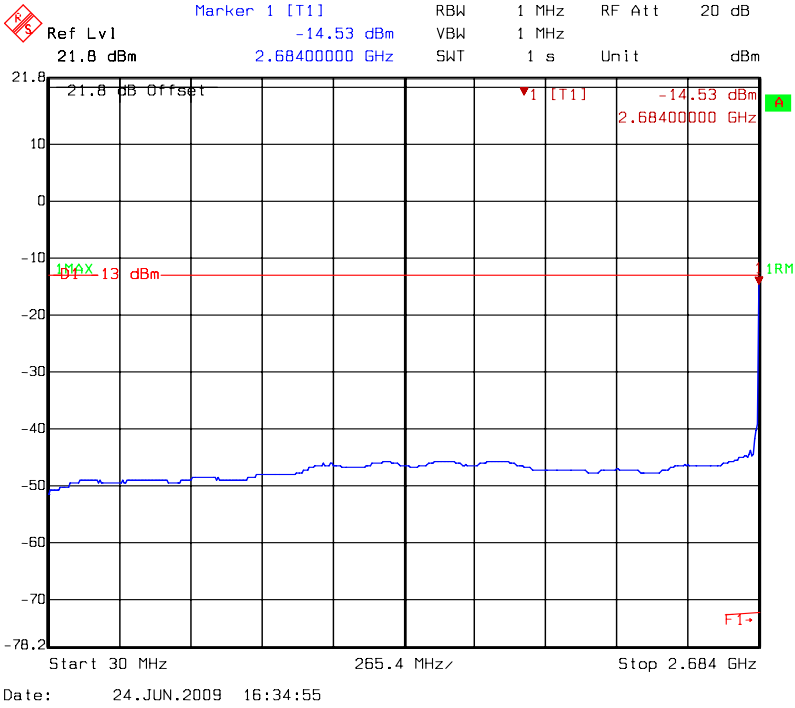

Spurious Emission at Antenna Terminals @ high channel (5MHz) - 2 of 4

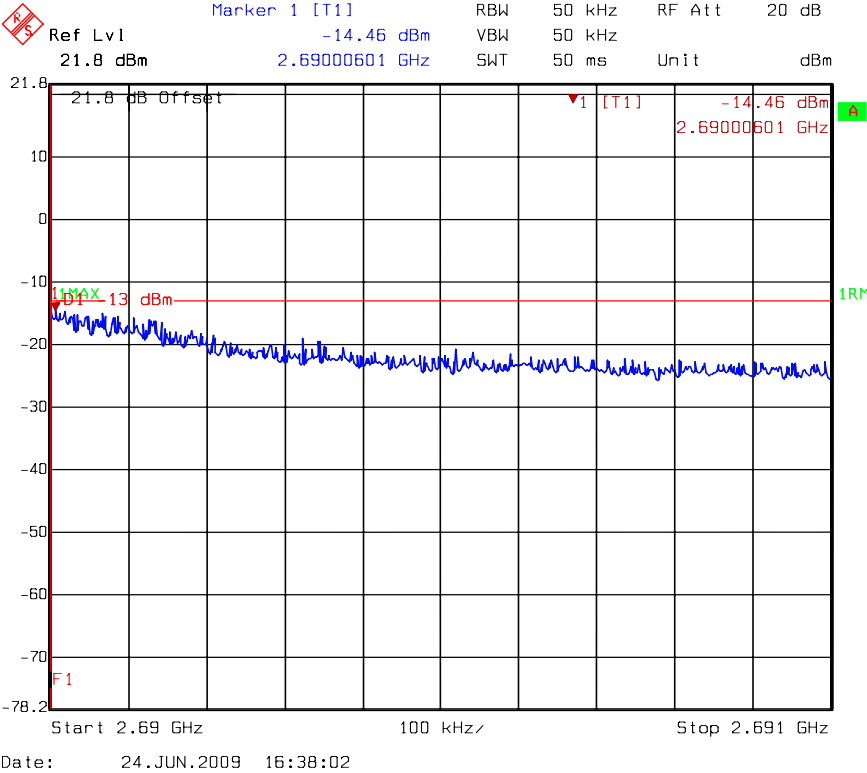

Spurious Emission at Antenna Terminals @ high channel (5MHz) - 3 of 4

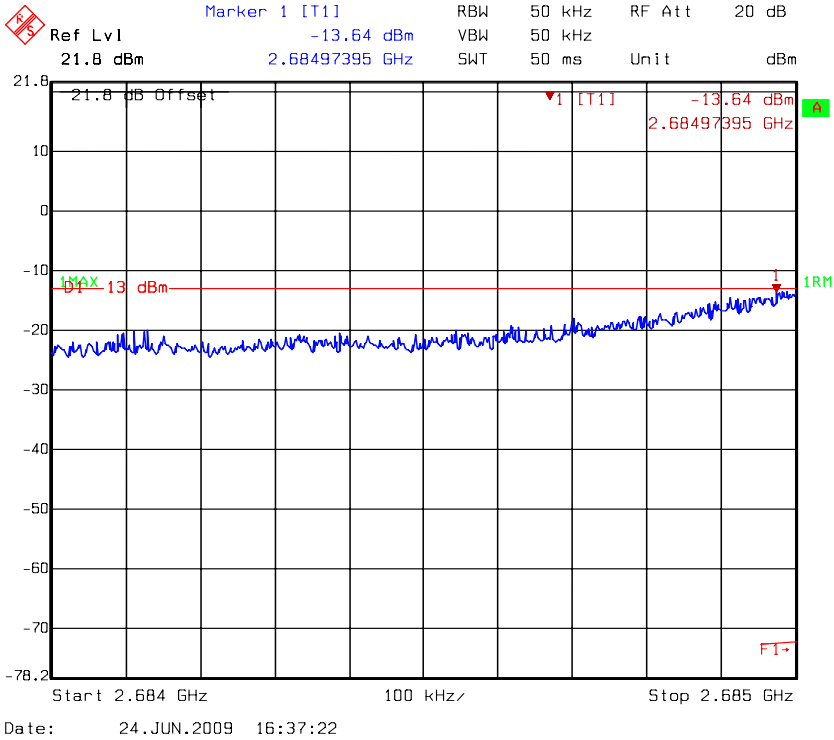

Spurious Emission at Antenna Terminals @ high channel (5MHz) - 4 of 4

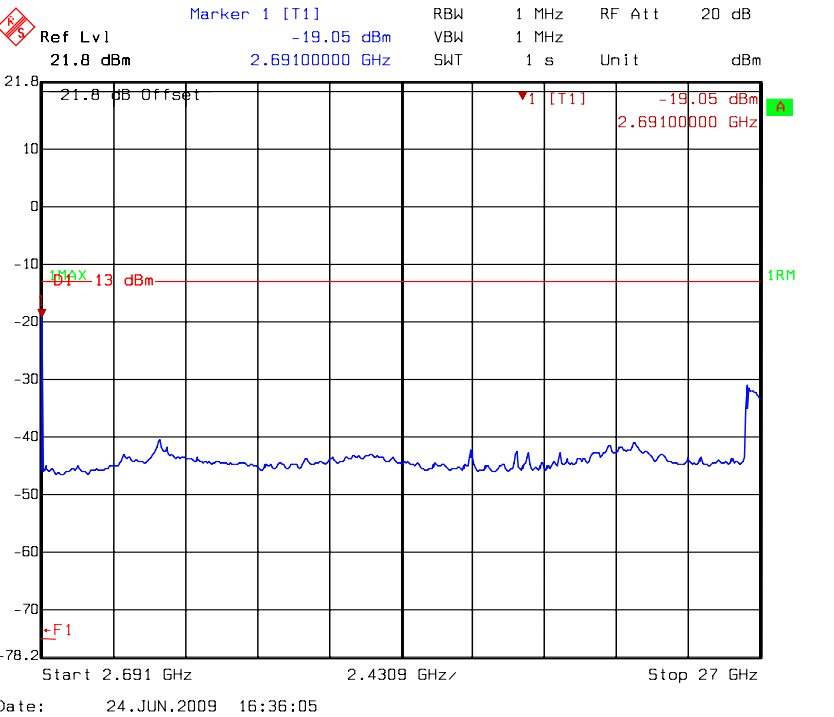

Spurious Emission at Antenna Terminals @ low channel (10MHz) - 1 of 4

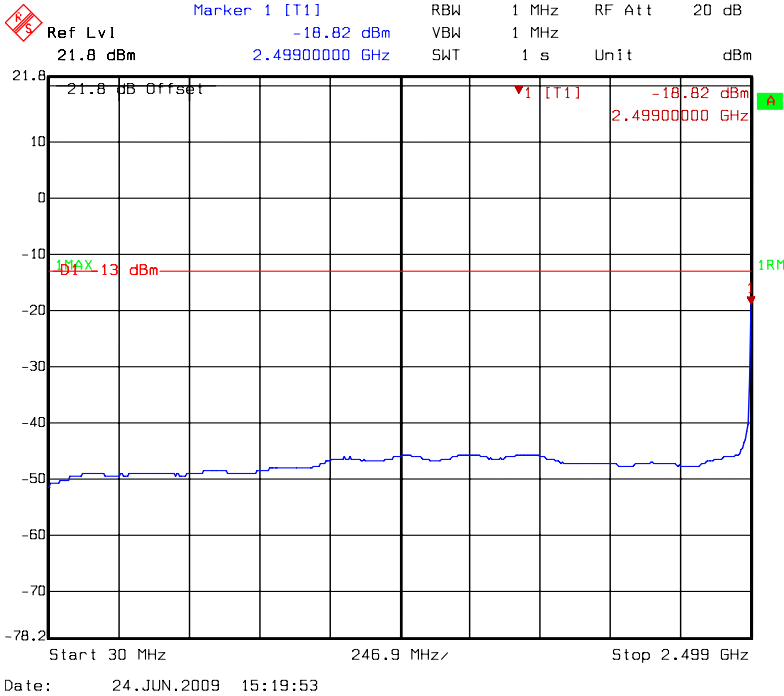

Spurious Emission at Antenna Terminals @ low channel (10MHz) - 2 of 4

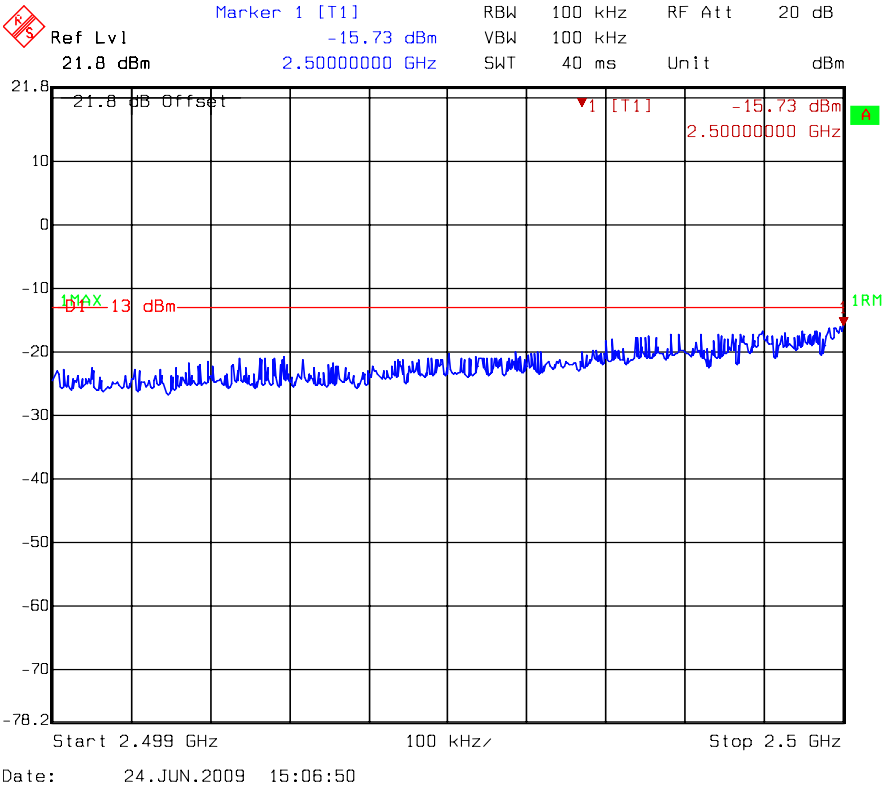

Spurious Emission at Antenna Terminals @ low channel (10MHz) - 3 of 4

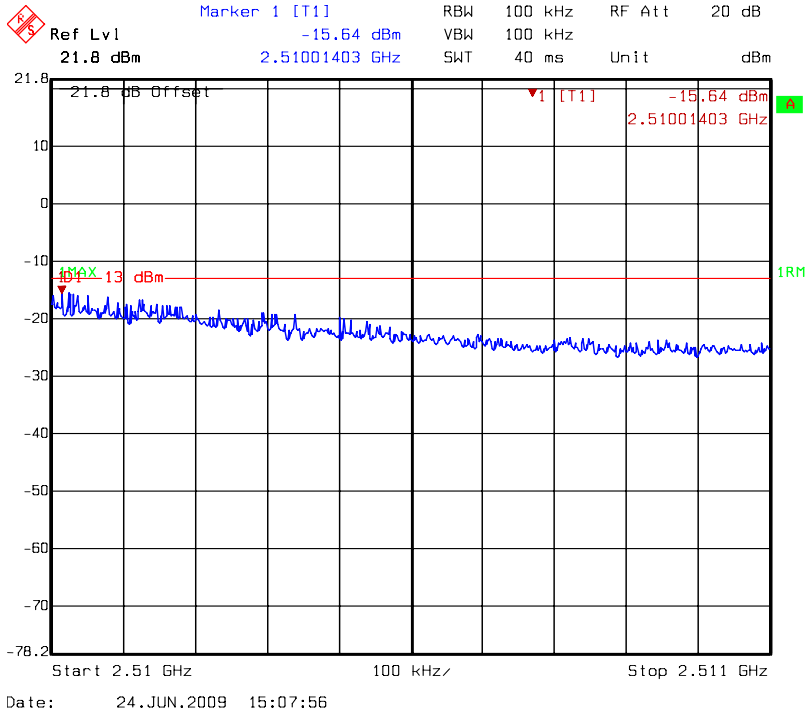

Spurious Emission at Antenna Terminals @ low channel (10MHz) - 4 of 4

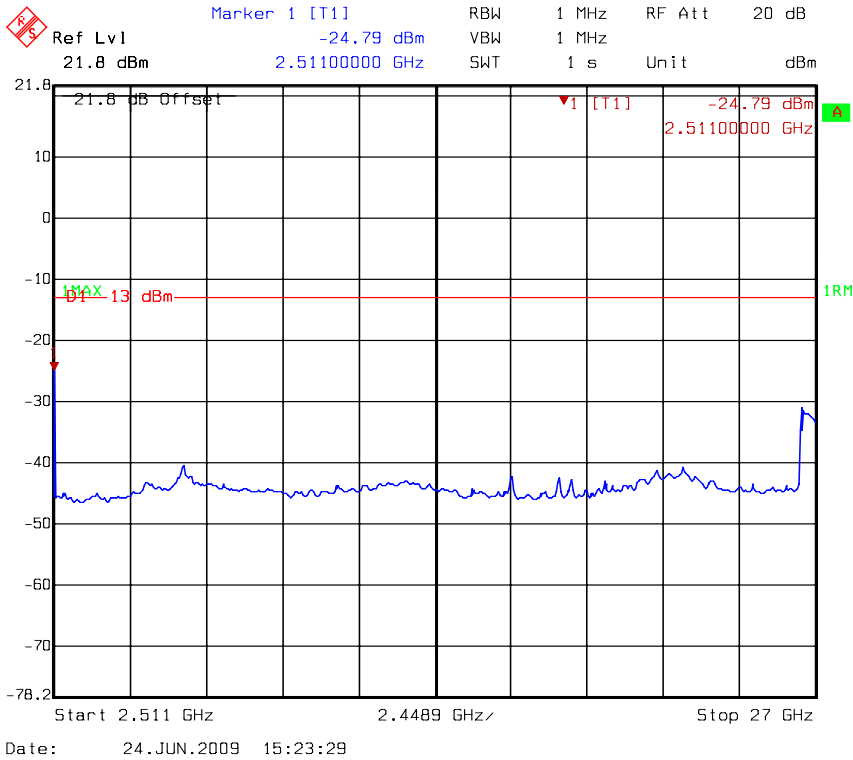

Spurious Emission at Antenna Terminals @ middle channel (10MHz) - 1 of 4

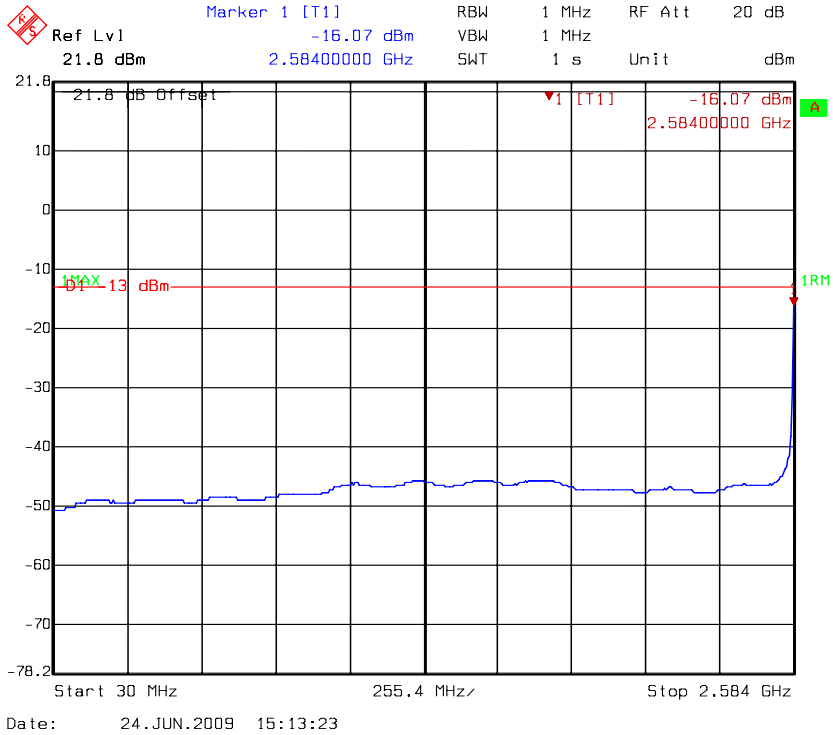

Spurious Emission at Antenna Terminals @ middle channel (10MHz) - 2 of 4

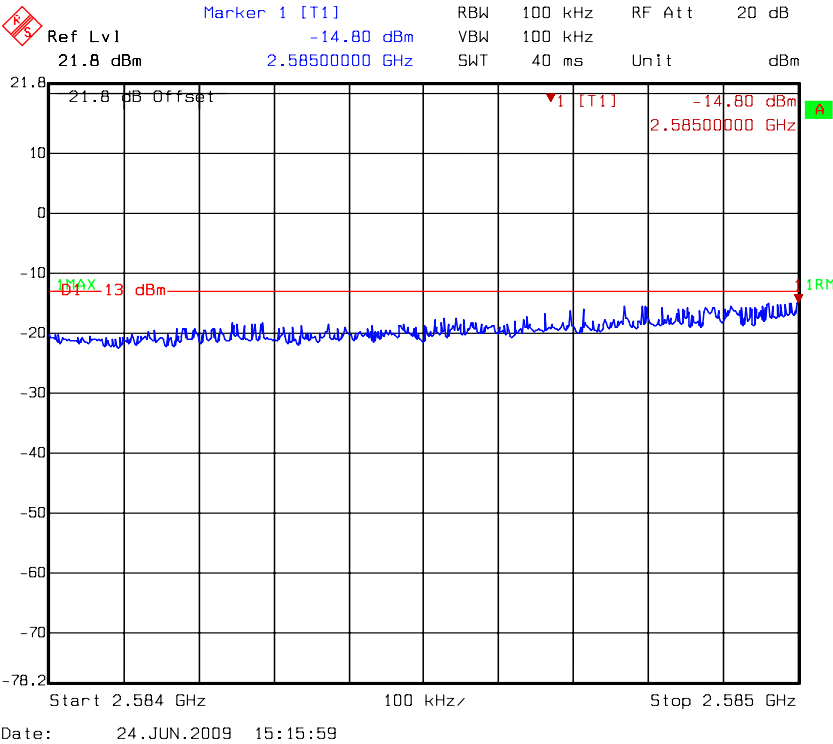

Spurious Emission at Antenna Terminals @ middle channel (10MHz) - 3 of 4

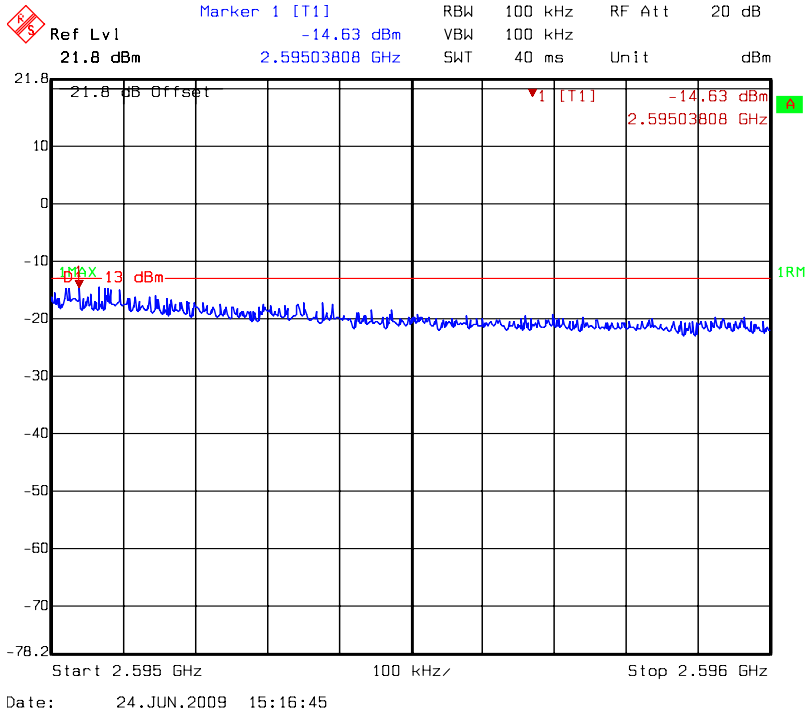

Spurious Emission at Antenna Terminals @ middle channel (10MHz) - 4 of 4

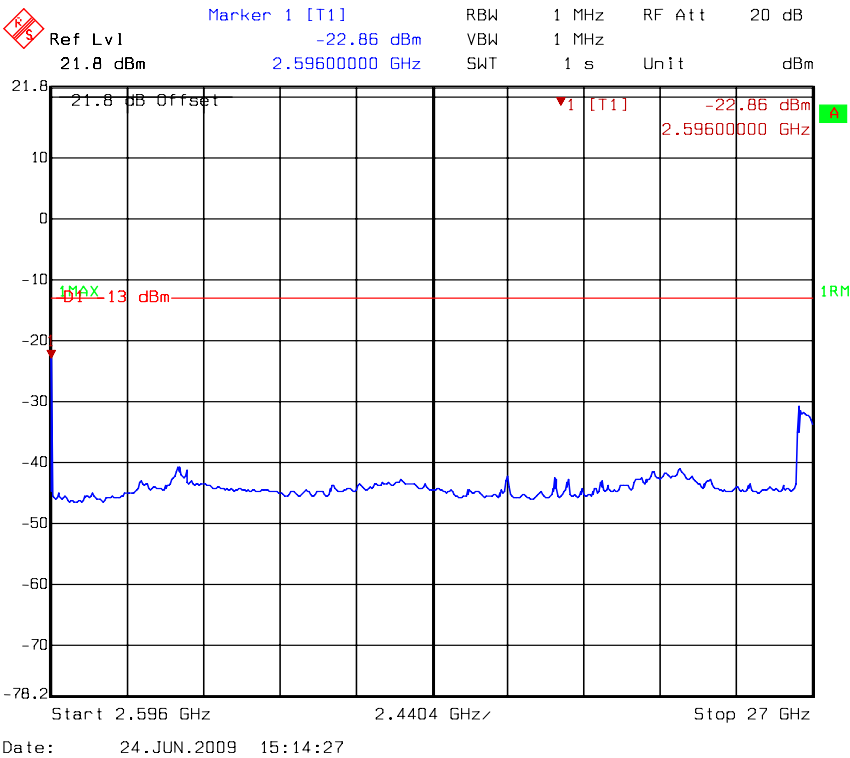



Spurious Emission at Antenna Terminals @ high channel (10MHz) - 1 of 4

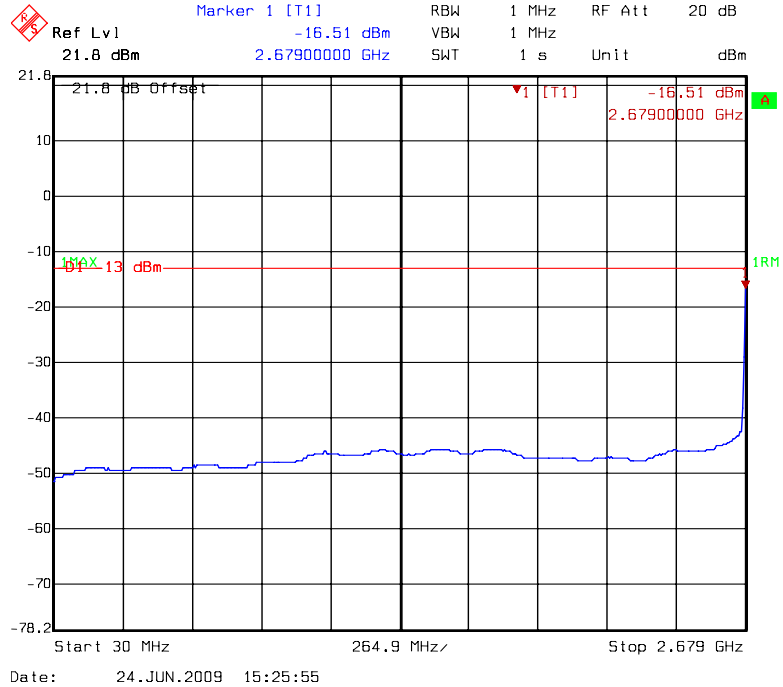

Spurious Emission at Antenna Terminals @ high channel (10MHz) - 2 of 4

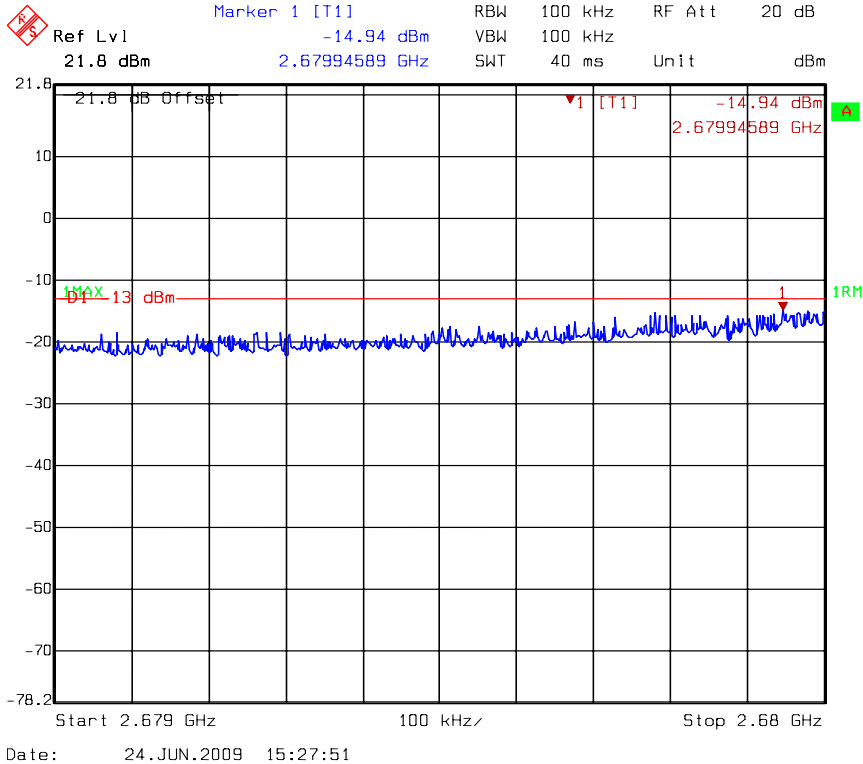

Spurious Emission at Antenna Terminals @ high channel (10MHz) - 3 of 4

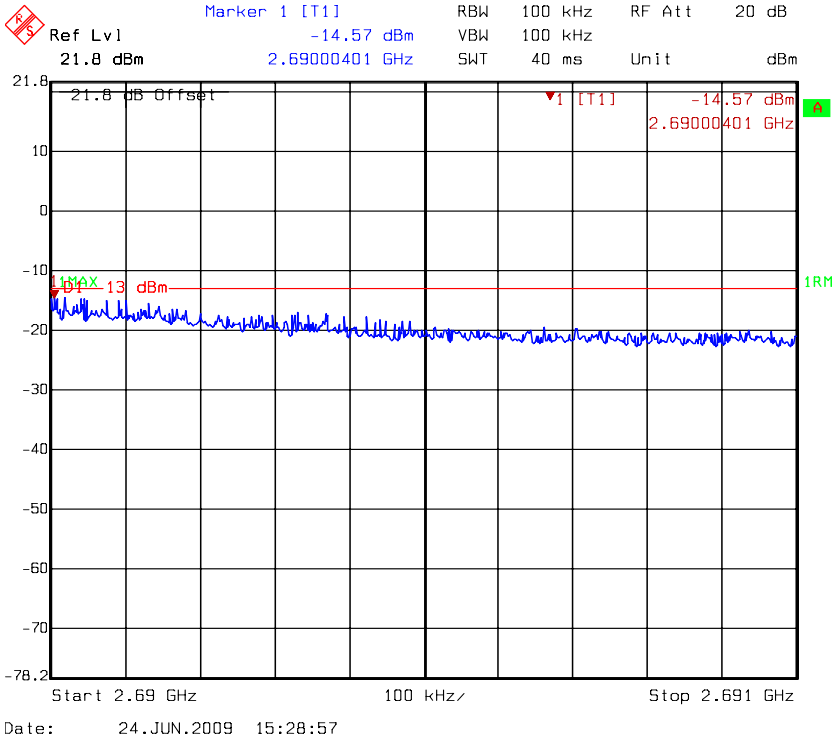

Spurious Emission at Antenna Terminals @ high channel (10MHz) - 4 of 4

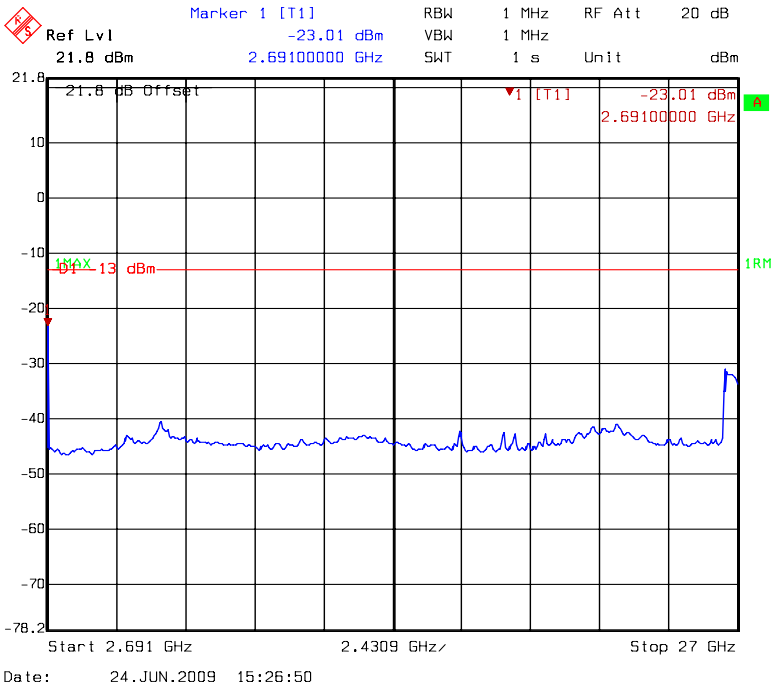

## 7. Field Strength of Spurious Radiation

<b>Base Standard</b>	FCC 27.53(m)(2)(v)
----------------------	--------------------

**Test Equipment:** EC1351, EC1353, EC1354, EC1365, EC1371,  
EC1373, EC1374, EP1364, EP1347

### 7.1 LIMITS OF Field Strength of Spurious Radiation MEASUREMENT

In the FCC 27.53(m)(2)(v), On any frequency outside a licensee's frequency block, For all fixed digital user stations, the attenuation factor shall be not less than  $43 + 10 \log (P)$  dB at the channel edge.

### 7.2 Test Procedure and Setup

If the antenna is detachable from the transmitter, it is removed and replaced with a 50 ohm load. Emissions are measured up to the 10<sup>th</sup> harmonic of the highest transmit frequency that the transmitter is capable of producing. If the antenna is not detachable from the transmitter, emissions are measured radiated only at a distance of 3 meters.

**Note:** (1) The EUT was tested while in a continuous transmit mode. The EUT was tuned to a low, middle and high channel.  
(2) The EUT operating at 2.5GHz band. Frequency Range scanned from 30MHz to 27GHz.

### 7.3 Method of Measurement

#### 7.3.1 Spurious Radiated Emission

The frequency range from 30MHz to 1000MHz using Bilog Antenna.

The frequency range over 1GHz using Horn Antenna.

The maximum field strength of the spurious emission is measured at a distance of 3 meters. The device under test is then replaced with a substitution antenna of known gain with respect to a Horn antenna. A calibrated signal source is used to feed the substitution antenna. The RF level to the substitution antenna is adjusted to repeat the previously measured field strength. The RF input level to the substitution antenna is the effective radiated power of the spurious emission after any correction for substitution antenna gain against a Horn antenna.

### 7.3.2 Radiated Field Strength

Radiated emissions were investigated cover the frequency range from 30MHz to 1000MHz using a receiver RBW of 120kHz record QP reading

The EUT for testing is arranged on a wooden turntable. If some peripherals apply to the EUT, the peripherals will be connected to EUT and the whole system. During the test, all cables were arranged to produce worst-case emissions. The signal is maximized through rotation. The height of antenna and polarization is changing constantly for exploring for maximum signal level. The height of antenna can be up to 4 meters and down to 1 meter.

The measurement for radiated emission will be done at the distance of three meters unless the signal level is too low to measure at that distance. In the case of the reading under noise floor, a pre-amplifier is used and/or the test is conducted at a closer distance. And then all readings are extrapolated back to the equivalent 3 meter reading using inverse scaling with distance.

## 7.4 Test Diagram

### 7.4.1 Spurious Radiated Emission

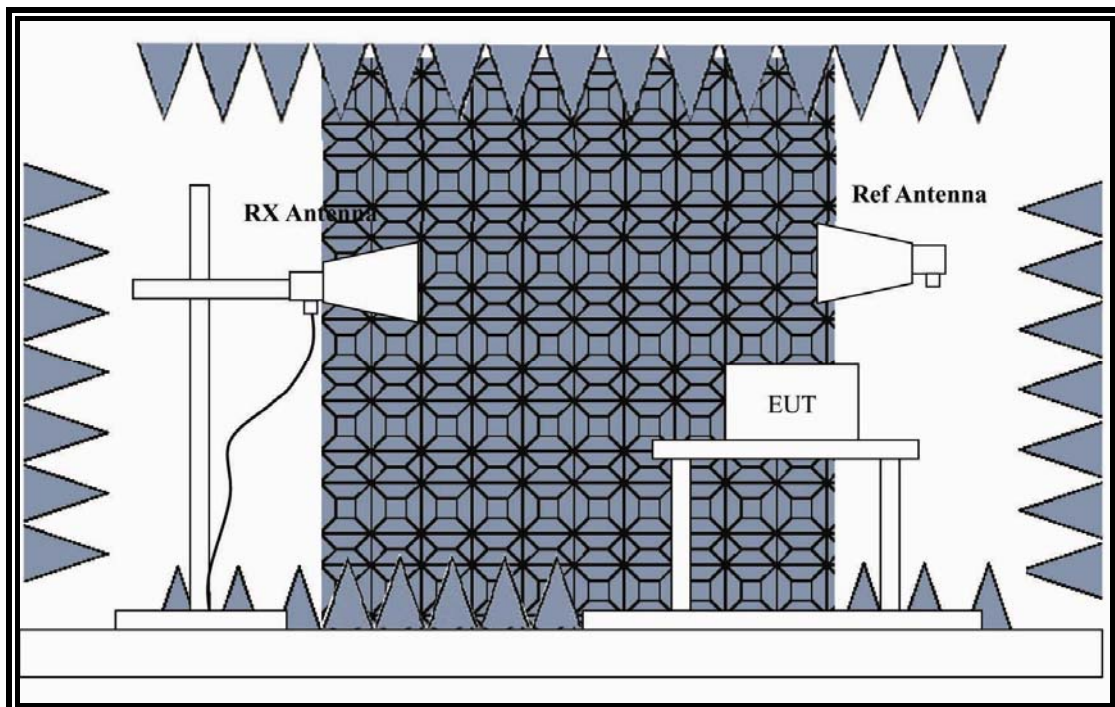

**7.4.2 Radiated Field Strength**

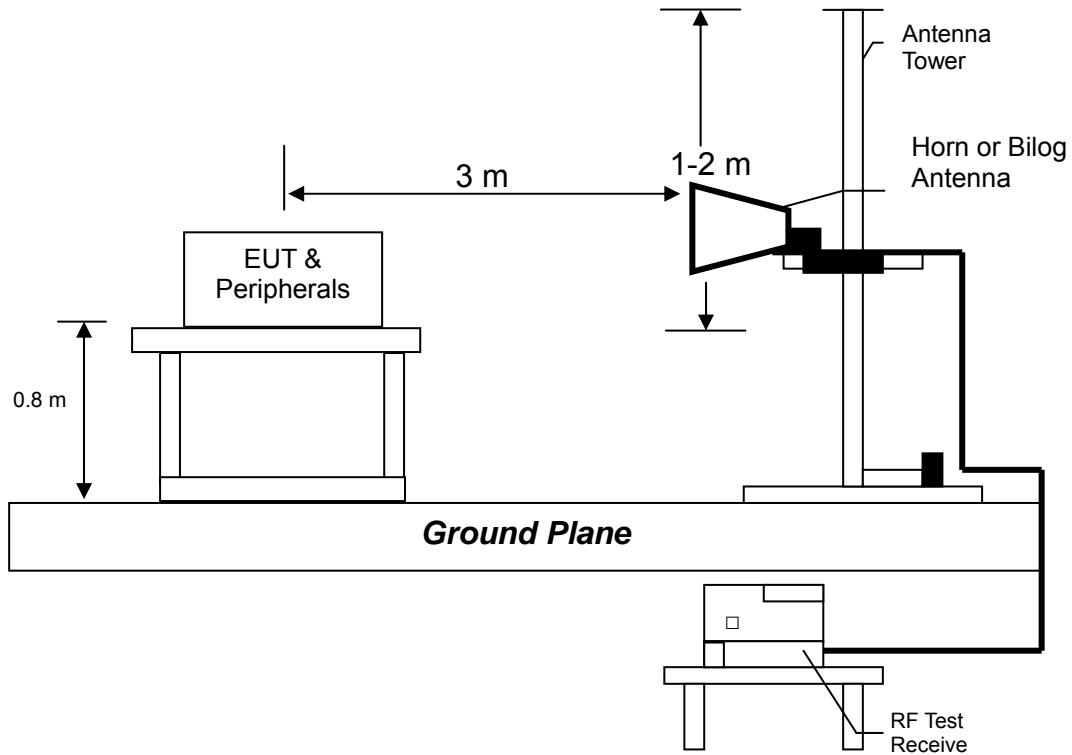

**7.5 Field Strength of Spurious Radiation Emission Limit**

**7.5.1 Spurious Radiated Emission**

According to FCC 27.53(m) requirement, the spurious emission shall be attenuated at least  $43 + 10 \log(P)$  dB from the fundamental.

Sample Calculation:

Assume the EUT Pout= 2W = 33dBm

$$43 + 10 \log(P)$$

$$43 + 10 \log(2)$$

$$43 + 10 \times 0.3$$

$$43 + 3 = 46 \text{ dB}$$

$$33 \text{ dBm} - 46 \text{ dB} = -13 \text{ dBm}$$

**7.5.2 Radiated Field Strength**

Frequency (MHz)	Distance(m)	Class A(dBµV/m)	Class B(dBµV/m)
30~230	10	40	30
230~1000	10	47	37

Note:

1. The tighter limit shall apply at the edge between two frequency bands.
2. Distance refers to the distance in meters between the measuring instrument Antenna and the closest point of EUT.

## 7.6 Test Result

Test Mode: Normal operating mode

Polarity (V/H)	Frequency (MHz)	Detector	Corr. Factor (dB/m)	Reading (dBuV)	Calculated dBuV/m	Limit (dBuV/m)	Margin (dB)
V	42.300	QP	13.43	10.20	23.63	30.00	-6.37
V	87.100	QP	9.97	11.30	21.27	30.00	-8.73
V	150.100	QP	11.80	10.50	22.30	30.00	-7.70
V	225.000	QP	11.76	11.80	23.56	30.00	-6.44
V	319.000	QP	16.38	13.60	29.98	37.00	-7.02
V	500.000	QP	20.60	8.30	28.90	37.00	-8.10
V	750.000	QP	23.61	3.90	27.51	37.00	-9.49
V	1000.000	QP	25.80	3.60	29.40	37.00	-7.60

Test Mode: Normal operating mode

Polarity (V/H)	Frequency (MHz)	Detector	Corr. Factor (dB/m)	Reading (dBuV)	Calculated dBuV/m	Limit (dBuV/m)	Margin (dB)
H	225.000	QP	11.76	9.70	21.46	30.00	-8.54
H	322.000	QP	16.45	10.20	26.65	37.00	-10.35
H	500.000	QP	20.60	7.70	28.30	37.00	-8.70
H	750.000	QP	23.61	5.00	28.61	37.00	-8.39
H	875.000	QP	24.65	4.80	29.45	37.00	-7.55
H	10000.000	QP	25.80	2.60	28.40	37.00	-8.60

Test Mode: Spurious Radiated Emission

Frequency (MHz)
<b>2502.5</b>

Polarity (V/H)	Frequency (MHz)	SG Level (dBm)	Cable Loss (dB)	Substitution Ant. Gain (dB)	Net (dBm)	Limit (dBm)	Margin (dB)	Band Width (MHz)
V	88.200	-61.38	1.51	0.51	-62.38	-13	-49.38	5
V	111.480	-59.41	1.72	0.54	-60.59	-13	-47.59	5
V	159.980	-63.78	2.14	2.6	-63.32	-13	-50.32	5
V	363.680	-58.34	3.21	6.15	-55.40	-13	-42.40	5
H	115.360	-56.22	1.72	0.54	-57.40	-13	-44.40	5
H	291.900	-66.57	2.87	5.98	-63.46	-13	-50.46	5
H	350.100	-68.07	3.18	6.21	-65.04	-13	-52.04	5

Polarity (V/H)	Frequency (MHz)	SG Level (dBm)	Cable Loss (dB)	Substitution Ant. Gain (dB)	Net (dBm)	Limit (dBm)	Margin (dB)	Band Width (MHz)
V	5010	-39.23	4.45	9.5	-34.18	-13	-21.18	5
H	5010	-39.23	4.45	9.5	-34.18	-13	-21.18	5
V	7500	-27.20	5.27	10.0	-22.47	-13	-9.47	5
H	7500	-35.56	5.27	10.0	-30.83	-13	-17.83	5
V	10020	-44.31	6.23	11.3	-39.24	-13	-26.24	5
H	10020	-47.06	6.23	11.3	-41.99	-13	-28.99	5
V	12510	-46.61	6.51	12.4	-40.72	-13	-27.72	5
H	12510	-49.50	6.51	12.4	-43.61	-13	-30.61	5

Remark: Net = SG Level - Cable Loss + Substitution Ant. Gain

**Frequency (MHz)**

**2590**

Polarity (V/H)	Frequency (MHz)	SG Level (dBm)	Cable Loss (dB)	Substitution Ant. Gain (dB)	Net (dBm)	Limit (dBm)	Margin (dB)	Band Width (MHz)
V	92.080	-57.94	0.40	0.92	-57.42	-13	-44.42	5
V	297.720	-67.44	0.30	5.92	-61.82	-13	-48.82	5
V	363.680	-65.57	0.40	6.14	-59.83	-13	-46.83	5
V	499.480	-63.64	0.70	6.20	-58.14	-13	-45.14	5
H	113.420	-55.43	1.80	0.55	-56.68	-13	-43.68	5
H	291.900	-67.39	2.87	6.01	-64.25	-13	-51.25	5
H	745.860	-61.74	4.85	5.60	-60.99	-13	-47.99	5

Polarity (V/H)	Frequency (MHz)	SG Level (dBm)	Cable Loss (dB)	Substitution Ant. Gain (dB)	Net (dBm)	Limit (dBm)	Margin (dB)	Band Width (MHz)
V	5160	-43.72	4.50	10.0	-38.22	-13	-25.22	5
H	5160	-46.18	4.50	10.0	-40.68	-13	-27.68	5
V	7770	-36.90	5.31	10.1	-32.11	-13	-19.11	5
H	7770	-35.25	5.31	10.1	-30.46	-13	-17.46	5
V	10350	-44.64	6.31	11.5	-39.45	-13	-26.45	5
H	10350	-50.75	6.31	11.5	-45.56	-13	-32.56	5
V	12960	-48.55	6.79	11.3	-44.04	-13	-31.04	5
H	12960	-47.07	6.79	11.3	-42.56	-13	-29.56	5

Remark: Net = SG Level - Cable Loss + Substitution Ant. Gain



**Frequency (MHz)**

**2687.5**

Polarity (V/H)	Frequency (MHz)	SG Level (dBm)	Cable Loss (dB)	Substitution Ant. Gain (dB)	Net (dBm)	Limit (dBm)	Margin (dB)	Band Width (MHz)
V	90.140	-57.12	1.61	0.89	-57.84	-13	-44.84	5
V	299.660	-65.42	2.89	5.97	-62.34	-13	-49.34	5
V	363.680	-62.44	3.22	6.23	-59.43	-13	-46.43	5
V	499.480	-59.88	3.77	6.20	-57.45	-13	-44.45	5
H	115.360	-55.21	1.83	0.25	-56.79	-13	-43.79	5
H	293.840	-66.75	2.87	5.98	-63.64	-13	-50.64	5
H	749.740	-58.89	4.89	5.51	-58.27	-13	-45.27	5

Polarity (V/H)	Frequency (MHz)	SG Level (dBm)	Cable Loss (dB)	Substitution Ant. Gain (dB)	Net (dBm)	Limit (dBm)	Margin (dB)	Band Width (MHz)
V	3570	-45.07	3.73	9.0	-39.80	-13	-26.8	5
H	3570	-55.04	3.73	9.0	-49.77	-13	-36.77	5
V	5370	-32.00	4.51	9.5	-27.01	-13	-14.01	5
H	5370	-37.24	4.51	9.5	-32.25	-13	-19.25	5
V	8070	-43.15	5.48	10.3	-38.33	-13	-25.33	5
H	8070	-39.18	5.48	10.3	-34.36	-13	-21.36	5
V	10770	-51.09	6.15	11.8	-45.44	-13	-32.44	5
H	10740	-50.93	6.15	11.8	-45.28	-13	-32.28	5

Remark: Net = SG Level - Cable Loss + Substitution Ant. Gain

**Frequency (MHz)**

**2505**

Polarity (V/H)	Frequency (MHz)	SG Level (dBm)	Cable Loss (dB)	Substitution Ant. Gain (dB)	Net (dBm)	Limit (dBm)	Margin (dB)	Band Width (MHz)
V	92.080	-61.78	1.61	0.87	-62.52	-13	-49.52	10
V	156.100	-61.20	2.08	2.57	-60.71	-13	-47.71	10
V	480.080	-67.49	3.70	6.08	-65.11	-13	-52.11	10
V	934.040	-55.38	5.03	5.01	-55.40	-13	-42.40	10
H	113.420	-56.10	1.83	0.48	-57.45	-13	-44.45	10
H	291.900	-67.31	2.88	5.94	-64.25	-13	-51.25	10
H	749.740	-58.25	4.89	5.52	-57.62	-13	-44.62	10

Polarity (V/H)	Frequency (MHz)	SG Level (dBm)	Cable Loss (dB)	Substitution Ant. Gain (dB)	Net (dBm)	Limit (dBm)	Margin (dB)	Band Width (MHz)
V	4980	-42.01	4.46	9.5	-36.97	-13	-23.97	10
H	5010	-38.92	4.46	9.5	-33.88	-13	-20.88	10
V	7500	-33.96	5.27	10.1	-29.13	-13	-16.13	10
H	7500	-36.32	5.27	10.1	-31.49	-13	-18.49	10
V	10020	-50.02	6.23	11.2	-45.05	-13	-32.05	10
H	10020	-49.97	6.23	11.2	-45.00	-13	-32.00	10
V	12540	-54.53	6.52	12.4	-48.63	-13	-35.63	10
H	12540	-48.71	6.52	12.4	-42.81	-13	-29.81	10

Remark: Net = SG Level - Cable Loss + Substitution Ant. Gain

**Frequency (MHz)**

**2590**

Polarity (V/H)	Frequency (MHz)	SG Level (dBm)	Cable Loss (dB)	Substitution Ant. Gain (dB)	Net (dBm)	Limit (dBm)	Margin (dB)	Band Width (MHz)
V	94.020	-55.85	1.68	0.50	-57.03	-13	-44.03	10
V	301.600	-65.38	2.91	5.97	-62.32	-13	-49.32	10
V	363.680	-62.06	3.22	6.25	-59.03	-13	-46.03	10
V	499.480	-60.91	3.77	6.20	-58.48	-13	-45.48	10
H	115.360	-56.58	1.80	0.40	-57.98	-13	-44.98	10
H	291.900	-67.77	2.87	5.93	-64.71	-13	-51.71	10
H	350.100	-69.12	3.18	6.20	-66.10	-13	-53.10	10
H	377.260	-68.45	3.22	6.37	-65.30	-13	-52.30	10

Polarity (V/H)	Frequency (MHz)	SG Level (dBm)	Cable Loss (dB)	Substitution Ant. Gain (dB)	Net (dBm)	Limit (dBm)	Margin (dB)	Band Width (MHz)
V	3450	-56.51	3.70	8.9	-51.31	-13	-38.31	10
H	3450	-64.58	3.70	8.9	-59.38	-13	-46.38	10
V	5160	-48.69	4.51	9.7	-43.50	-13	-30.50	10
H	5160	-45.88	4.51	9.7	-40.69	-13	-27.69	10
V	7770	-39.19	5.34	10.2	-34.33	-13	-21.33	10
H	7770	-39.61	5.34	10.2	-34.75	-13	-21.75	10
V	10350	-48.09	6.01	11.4	-42.70	-13	-29.70	10
H	10350	-50.09	6.01	11.4	-44.70	-13	-31.70	10

Remark: Net = SG Level - Cable Loss + Substitution Ant. Gain

**Frequency (MHz)**

**2685**

Polarity (V/H)	Frequency (MHz)	SG Level (dBm)	Cable Loss (dB)	Substitution Ant. Gain (dB)	Net (dBm)	Limit (dBm)	Margin (dB)	Band Width (MHz)
V	86.260	-58.03	1.52	0.52	-59.03	-13	-46.03	10
V	363.680	-62.26	3.21	6.24	-59.23	-13	-46.23	10
V	499.480	-60.79	3.77	6.20	-58.36	-13	-45.36	10
H	113.420	-55.49	1.83	0.35	-56.97	-13	-43.97	10
H	289.960	-66.47	2.88	5.93	-63.42	-13	-50.42	10
H	749.740	-57.54	4.89	5.52	-56.91	-13	-43.91	10

Polarity (V/H)	Frequency (MHz)	SG Level (dBm)	Cable Loss (dB)	Substitution Ant. Gain (dB)	Net (dBm)	Limit (dBm)	Margin (dB)	Band Width (MHz)
V	3570	-43.40	3.72	9.0	-38.12	-13	-25.12	10
H	3570	-52.73	3.72	9.0	-47.45	-13	-34.45	10
V	5340	-41.63	4.51	9.4	-36.74	-13	-23.74	10
H	5340	-37.87	4.51	9.4	-32.98	-13	-19.98	10
V	8040	-47.40	5.48	10.3	-42.58	-13	-29.58	10
H	8070	-45.46	5.48	10.3	-40.64	-13	-27.64	10
V	10740	-52.66	6.15	11.8	-47.01	-13	-34.01	10
H	10740	-55.37	6.15	11.8	-49.72	-13	-36.72	10

Remark: Net = SG Level - Cable Loss + Substitution Ant. Gain

## 8. AC power line conducted emission

<b>Base Standard</b>	FCC 15.207
----------------------	------------

**Test Equipment:** EC1303

### 8.1 Method of Measurement

The EUT are connected to the main power through a line impedance stabilization network (LISN). This provides a 50 ohm/50uH coupling impedance for the measuring equipment. The peripheral devices are also connected to the main power through a LISN that provides a 50ohm/50uH coupling impedance with 50ohm termination. Both sides (Line and Neutral) of AC line are checked for maximum conducted interference. In order to find the maximum emission, the relative positions of equipment and all of the interface cables must be changed according to ANSI C63.4/2003 on conducted measurement. The bandwidth of the field strength meter (R & S Test Receiver ESCS 30) is set at 9kHz.

### 8.2 Test Diagram

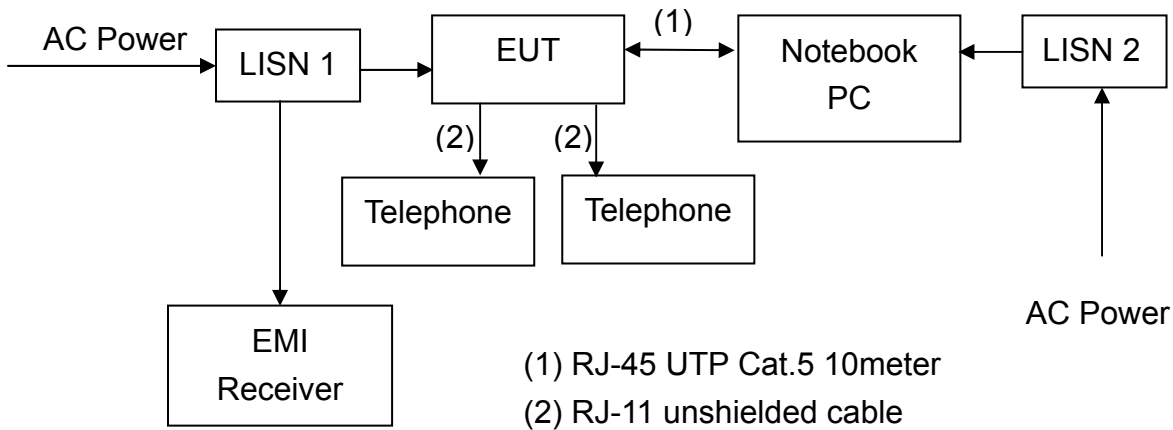

**8.3 Emission Limit**

Freq. (MHz)	Conducted Limit (dBuV)	
	Q.P.	Ave.
0.15~0.50	66 – 56*	56 – 46*
0.50~5.00	56	46
5.00~30.0	60	50

\*Decreases with the logarithm of the frequency.

**8.4 Test Result**

Phase : Line  
EUT : MAX-206M1R  
Test Condition : Normal operating mode

Frequency (MHz)	Corr. Factor (dB)	Level Qp (dBuV)	Limit Qp (dBuV)	Level Av (dBuV)	Limit Av (dBuV)	Margin (dB)	
						Qp	Av
0.16	0.81	61.26	65.52	48.23	55.52	-4.26	-7.29
0.21	0.77	59.58	63.32	45.20	53.32	-3.74	-8.12
0.23	0.65	61.68	62.39	47.03	52.39	-0.71	-5.36
0.26	0.56	58.04	61.56	46.10	51.56	-3.52	-5.46
0.28	0.45	56.09	60.68	41.66	50.68	-4.58	-9.01
0.31	0.36	55.69	59.93	40.46	49.93	-4.24	-9.47
0.47	0.11	49.62	56.45	38.65	46.45	-6.83	-7.80
0.53	0.11	48.89	56.00	39.35	46.00	-7.11	-6.65
0.92	0.11	46.68	56.00	31.37	46.00	-9.32	-14.63
1.20	0.12	43.21	56.00	30.81	46.00	-12.79	-15.19
1.82	0.14	45.67	56.00	34.28	46.00	-10.33	-11.72
2.95	0.22	47.28	56.00	36.18	46.00	-8.72	-9.82

**Remark:**

1. Correction Factor (dB)= LISN Factor (dB) + Cable Loss (dB)
2. Margin (dB) = Level (dBuV) – Limit (dBuV)

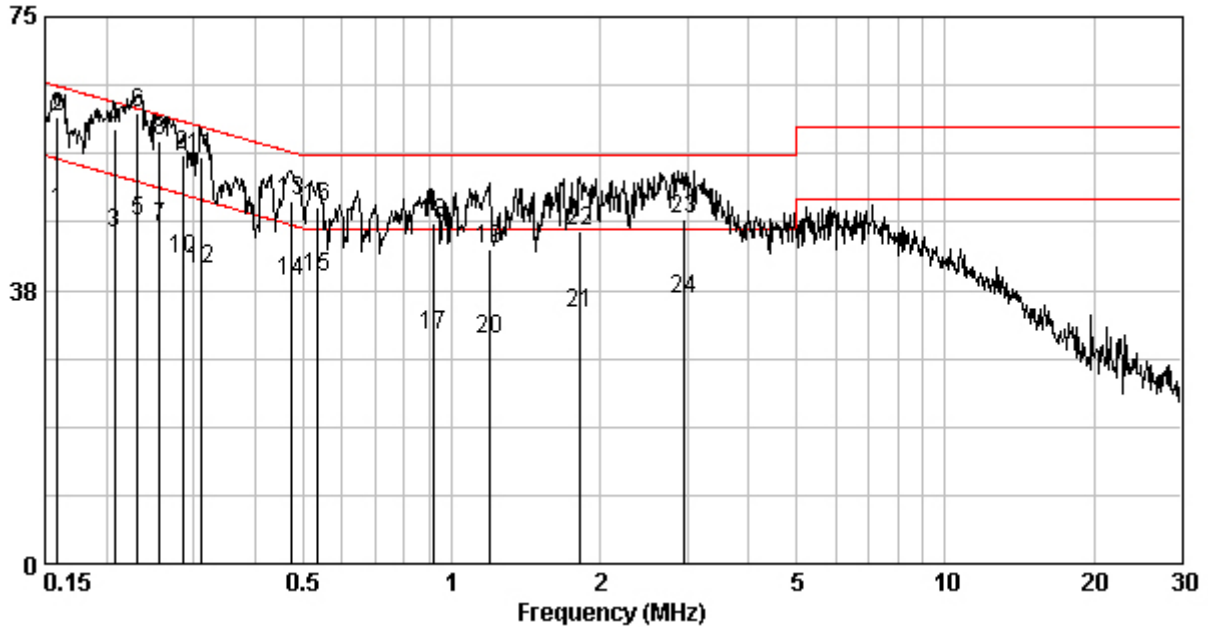

Phase : Neutral  
EUT : MAX-206M1R  
Test Condition : Normal operating mode

Frequency (MHz)	Corr. Factor (dB)	Level Qp (dBuV)	Limit Qp (dBuV)	Level Av (dBuV)	Limit Av (dBuV)	Margin (dB)	
						Qp	Av
0.16	0.11	55.91	65.52	40.08	55.52	-9.61	-15.44
0.22	0.11	54.14	62.70	40.73	52.70	-8.56	-11.97
0.23	0.11	54.99	62.57	39.86	52.57	-7.58	-12.71
0.26	0.11	54.15	61.56	43.52	51.56	-7.41	-8.04
0.31	0.11	50.87	59.84	38.93	49.84	-8.97	-10.91
0.48	0.11	48.16	56.27	35.48	46.27	-8.12	-10.80
0.53	0.11	48.02	56.00	39.05	46.00	-7.98	-6.95
0.64	0.11	44.37	56.00	30.58	46.00	-11.63	-15.42
0.91	0.11	45.14	56.00	32.19	46.00	-10.86	-13.81
1.19	0.12	43.92	56.00	31.51	46.00	-12.08	-14.49
1.62	0.13	43.31	56.00	33.08	46.00	-12.69	-12.92
2.74	0.21	45.21	56.00	36.42	46.00	-10.79	-9.58
3.06	0.23	44.92	56.00	35.51	46.00	-11.08	-10.49

**Remark:**

1. Correction Factor (dB) = LISN Factor (dB) + Cable Loss (dB)
2. Margin (dB) = Level (dBuV) – Limit (dBuV)

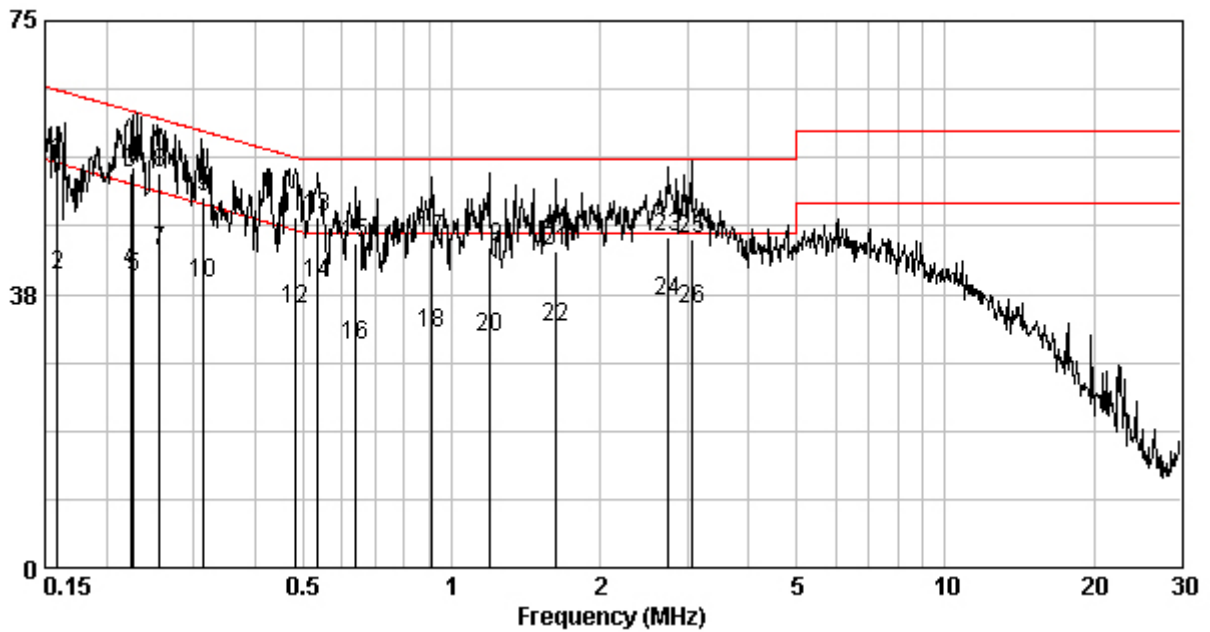



## 9. Frequency Stability

<b>Base Standard</b>	FCC 2.1055 & 27.54
----------------------	--------------------

**Test Equipment:** EC1365

### 9.1 Method of Measurement

According to the FCC part 2.1055 shall be tested the frequency stability. The rule is defined that” The frequency stability shall be sufficient to ensure that the fundamental emission stays within the authorized frequency block.” The test extreme voltage is according to the 2.1055(d)(1) Vary primary supply voltage from 85 to 115 percent of the nominal value for other than hand carried battery equipment and the extreme temperature rule is comply with specification of EUT  $-30^{\circ}\text{C} \sim 50^{\circ}\text{C}$ .

**Note:** The EUT has been verified frequency stability of 5MHz and 10MHz Bandwidth, the temperature range from  $-30^{\circ}\text{C} \sim +50^{\circ}\text{C}$  in normal supplied voltage and the supplied voltage range from 85 to 115 percent of the nominal value in normal temperature.

**9.2 Test Result****For 5MHz BW**

Frequency (MHz)	Temperature (°C)	Test Results (ppm)
2590	50	-1.91
	40	-0.68
	30	-1.23
	20	-2.68
	10	-3.36
	0	-1.41
	-10	-0.46
	-20	-1.23
	-30	-1.64

Frequency	Mains Voltage (Volts)	Tolerance (ppm)
2502.5	102	-5.82
	120	-5.13
	138	-4.74
2590	102	-2.62
	120	-0.35
	138	0.81
2687.5	102	2.11
	120	1.48
	138	-0.84

**For 10MHz BW**

Frequency (MHz)	Temperature (°C)	Test Results (ppm)
2590	50	1.75
	40	-2.35
	30	1.33
	20	3.82
	10	1.28
	0	-1.01
	-10	1.88
	-20	0.85
	-30	0.06

Frequency	Mains Voltage (Volts)	Tolerance (ppm)
2505	102	0.34
	120	0.56
	138	1.38
2590	102	1.17
	120	0.81
	138	0.45
2685	102	-0.64
	120	-0.63
	138	-0.59

## Attachment 1: PHY Profile

1 **4. PHY Profile**

2 **4.1 Profiles of BS and MS**

3  
4 **4.1.1 System Parameters**

5  
6 **4.1.1.1 PHY Mode**

7 **Table 5. PHY Mode**

Item	Description	Reference	Status	BS Required	MS Required	Comment
1	OFDMA	8.4	m	Y	Y	OFDMA is the sole PHY mode within the scope of this document.

8  
9 **4.1.1.2 Band Class Index**

10  
11 System profile requirements of this document are applied to the following band class indices. Each index shall specify one frequency range and one or more combinations of channel bandwidth, FFT size, channel raster and duplexing mode.

12  
13  
14 BS support for a particular band class requires support of a frequency range that is a subset of the complete frequency range defined by the band-class. The BS vendor shall provide a declaration of the supported frequency range. The supported frequency range shall be a minimum of three (3) times the largest supported channel bandwidth. MS must support the entire range of frequency defined by a band class (or sub-bands) while the BS is required to support only sub-range of the band class declared by vendor.

22 **Table 6. Band Class Index**

Band Class Index	Frequency Range (CHz)	Channel Frequency Step (kHz)	Channel Bandwidth(s) (MHz)	FFT Size	Duplexing Mode	Comments
1	2.3-2.4	250	5	512	TDD	Both bandwidths must be supported by the MS
			10	1024	TDD	
			8.75	1024	TDD	
2	2.305-2.320, 2.345-2.360	250	3.5	512	TDD	
			5	512	TDD	
			10	1024	TDD	
3	2.496-2.69	250 (200 KHz step size is also	5	512	TDD	Both bandwidths must be supported
			10	1024	TDD	

WiMAX Forum™ Mobile System Profile  
Release 1.0 Approved Specification

(Revision 1.6.1: 2008-04-01)

		recommended for band class 3 in Europe)				to by the MS
4	3.3-3.4	250	5	512	TDD	
			7	1024	TDD	
			10	1024	TDD	
5	3.4-3.8	250	5	512	TDD	
			7	1024	TDD	
			10	1024	TDD	
	3.4-3.6	250	5	512	TDD	
			7	1024	TDD	
			10	1024	TDD	
3.6-3.8	250	5	512	TDD		
		7	1024	TDD		
		10	1024	TDD		

1  
2  
3

**4.1.1.3 Sampling Factor**

**Table 7. Sampling Factor**

Item	Description	Reference	Status	BS Required	MS Required	Comment
1	If channel bandwidth is a multiple of 1.75MHz then n=8/7 else if channel bandwidth is a multiple of any of 1.25, 1.5, 2 or 2.75 MHz then n=28/25 else if not otherwise specified then n=8/7.	8.4.2.3	m	Y	Y	

5  
6

**4.1.1.4 Cyclic Prefix**

**Table 8. Cyclic Prefix**

Item	Description	Reference	Status	BS Required	MS Required	Comment
1	1/4	8.4.2.3	oi	N	N	
2	1/8	8.4.2.3	oi	Y	Y	
3	1/16	8.4.2.3	oi	N	N	
4	1/32	8.4.2.3	oi	N	N	

8  
9

**4.1.1.5 Frame Length**

**Table 9. Frame Length**

Item	Description	Reference	Status	BS Required	MS Required	Comment
1	20 ms	8.4.5.2	oi	N	N	
2	12.5	8.4.5.2	oi	N	N	
3	10	8.4.5.2	oi	N	N	
4	8	8.4.5.2	oi	N	N	
5	5	8.4.5.2	oi	Y	Y	
6	4	8.4.5.2	oi	N	N	
7	2.5	8.4.5.2	oi	N	N	
8	2	8.4.5.2	oi	N	N	

10

## **Attachment 2: Power Class Profile**

1 **7. Power Class Profile**

2 The Power Classes listed in following table is developed to cover the complete target range of power  
 3 levels while different interpretation of applicable modulation levels is addressed through a dual range  
 4 requirement for QPSK and 16-QAM per Power Class.  
 5

6 **Table 131. Power Classes**

Class Identifier	Transmit Power (dBm) for 16-QAM	Transmit Power (dBm) for QPSK	MS Required
Power Class 1	18 ≤ PT <sub>x,max</sub> < 21	20 ≤ PT <sub>x,max</sub> < 23	oi
Power Class 2	21 ≤ PT <sub>x,max</sub> < 25	23 ≤ PT <sub>x,max</sub> < 27	oi
Power Class 3	25 ≤ PT <sub>x,max</sub> < 30	27 ≤ PT <sub>x,max</sub> < 30	oi
Power Class 4	30 ≤ PT <sub>x,max</sub>	30 ≤ PT <sub>x,max</sub>	oi

7  
 8 NOTE: The maximum MS output power may be limited by the value included in a MS Maximum  
 9 Transmission Power Limitation Control TLV that may be included in the UCD.