



FCC TEST REPORT (PART 27)

REPORT NO.: RF961108H05

MODEL NO.: MAX-200HW2

RECEIVED: Nov. 09, 2007

TESTED: Nov. 21 to Dec. 10, 2007

ISSUED: Dec. 11, 2007

APPLICANT: ZyXEL Communications Corporation

ADDRESS: No. 6, Innovation Road II, Science-Park, Hsin-Chu,
300, Taiwan

ISSUED BY : Advance Data Technology Corporation

LAB LOCATION : No. 81-1, Lu Liao Keng, 9 Ling, Wu Lung Tsuen,
Chiung Lin Hsiang, Hsin Chu Hsien, Taiwan.

This test report consists of 51 pages in total. It may be duplicated completely for legal use with the approval of the applicant. It should not be reproduced except in full, without the written approval of our laboratory. The client should not use it to claim product endorsement by TAF or any government agencies. The test results in the report only apply to the tested sample.





TABLE OF CONTENTS

1	CERTIFICATION	4
2	SUMMARY OF TEST RESULTS	5
2.1	MEASUREMENT UNCERTAINTY	6
3	GENERAL INFORMATION.....	7
3.1	GENERAL DESCRIPTION OF EUT.....	7
3.2	DESCRIPTION OF TEST MODES.....	8
3.2.1	TEST MODE APPLICABILITY AND TESTED CHANNEL DETAIL.....	9
3.3	GENERAL DESCRIPTION OF APPLIED STANDARDS.....	11
3.4	DESCRIPTION OF SUPPORT UNITS	11
3.4.1	CONFIGURATION OF SYSTEM UNDER TEST	12
4	TEST TYPES AND RESULTS	13
4.1	OUTPUT POWER MEASUREMENT	13
4.1.1	LIMITS OF OUTPUT POWER MEASUREMENT	13
4.1.2	TEST INSTRUMENTS	14
4.1.3	TEST PROCEDURES.....	15
4.1.4	TEST SETUP.....	16
4.1.5	EUT OPERATING CONDITIONS.....	16
4.1.6	TEST RESULTS.....	17
4.2	FREQUENCY STABILITY MEASUREMENT.....	18
4.2.1	LIMITS OF FREQUENCY STABILITY MEASUREMENT	18
4.2.2	TEST INSTRUMENTS	18
4.2.3	TEST PROCEDURE.....	19
4.2.4	TEST SETUP.....	19
4.2.5	TEST RESULTS.....	20
4.3	EMISSION BANDWIDTH MEASUREMENT.....	22
4.3.1	LIMITS OF EMISSION BANDWIDTH MEASUREMENT	22
4.3.2	TEST INSTRUMENTS	22
4.3.3	TEST SETUP.....	22
4.3.4	TEST PROCEDURES.....	23
4.3.5	TEST RESULTS.....	24
4.4	CHANNEL EDGE MEASUREMENT	26
4.4.1	LIMITS OF CHANNEL EDGE MEASUREMENT	26
4.4.2	TEST INSTRUMENTS	26
4.4.3	TEST SETUP	26
4.4.4	TEST PROCEDURES.....	27
4.4.5	EUT OPERATING CONDITION	27
4.4.6	TEST RESULTS.....	28
4.5	CONDUCTED SPURIOUS EMISSIONS	30
4.5.1	LIMITS OF CONDUCTED SPURIOUS EMISSIONS MEASUREMENT	30



4.5.2	TEST INSTRUMENTS	30
4.5.3	TEST PROCEDURE	31
4.5.4	TEST SETUP	31
4.5.5	EUT OPERATING CONDITIONS	31
4.5.6	TEST RESULTS.....	32
4.6	RADIATED EMISSION MEASUREMENT (BELOW 1GHz)	38
4.6.1	LIMITS OF RADIATED EMISSION MEASUREMENT	38
4.6.2	TEST INSTRUMENTS	39
4.6.3	TEST PROCEDURES.....	40
4.6.4	DEVIATION FROM TEST STANDARD	40
4.6.5	TEST SETUP	41
4.6.6	EUT OPERATING CONDITIONS	41
4.6.7	TEST RESULTS.....	42
4.7	RADIATED EMISSION MEASUREMENT (ABOVE 1GHz).....	43
4.7.1	LIMITS OF RADIATED EMISSION MEASUREMENT	43
4.7.2	TEST INSTRUMENTS	44
4.7.3	TEST PROCEDURES.....	45
4.7.4	DEVIATION FROM TEST STANDARD	45
4.7.5	TEST SETUP	46
4.7.6	EUT OPERATING CONDITIONS	46
4.7.7	TEST RESULTS.....	47
5	PHOTOGRAPHS OF THE TEST CONFIGURATION	50
6	INFORMATION ON THE TESTING LABORATORIES	51



1 CERTIFICATION

PRODUCT: Wimax Router

MODEL: MAX-200HW2

APPLICANT: ZyXEL Communications Corporation

TESTED: Nov. 21 to Dec. 10, 2007

TEST SAMPLE: R&D SAMPLE

TEST STANDARDS: FCC Part 27, Subpart C & M

ANSI C63.4-2003

The above equipment (Model no.: MAX-200HW2) has been tested by **Advance Data Technology Corporation**, and found compliance with the requirement of the above standards. The test record, data evaluation & Equipment Under Test (EUT) configurations represented herein are true and accurate accounts of the measurements of the sample's EMC characteristics under the conditions specified in this report.

PREPARED BY : Claire Kuan , **DATE:** Dec. 11, 2007
(Claire Kuan, Specialist)

TECHNICAL ACCEPTANCE : Hank Chung , **DATE:** Dec. 11, 2007
Responsible for RF (Hank Chung, Deputy Manager)

APPROVED BY : May Chen , **DATE:** Dec. 11, 2007
(May Chen, Deputy Manager)

2 SUMMARY OF TEST RESULTS

The EUT has been tested according to the following specifications:

APPLIED STANDARD: FCC Part 27 & Part 2			
STANDARD SECTION	TEST TYPE AND LIMIT	RESULT	REMARK
2.1046 27.50(h)(2)	Maximum Peak Output Power Limit: max. 2 watts e.i.r.p peak power	PASS	Meet the requirement of limit.
2.1055 27.54	Frequency Stability Stay with the authorized bands of operation	PASS	Meet the requirement of limit.
2.1049 27.53(l)(6)	Emission Bandwidth	PASS	Meet the requirement of limit.
2.1051 27.53(l)(4)(6)	Band Edge Measurements	PASS	Meet the requirement of limit.
2.1051 27.53(l)(4)(6)	Conducted Spurious Emissions	PASS	Meet the requirement of limit.
2.1053 27.53(l)(4)(6)	Radiated Spurious Emissions	PASS	Meet the requirement of limit.

2.1 MEASUREMENT UNCERTAINTY

Where relevant, the following measurement uncertainty levels have been estimated for tests performed on the EUT as specified in CISPR 16-4:

This uncertainty represents an expanded uncertainty expressed at approximately the 95% confidence level using a coverage factor of $k=2$.

Measurement	Value
Radiated emissions (30MHz-1GHz)	3.94 dB
Radiated emissions (1GHz -18GHz)	2.33 dB
Radiated emissions (18GHz -40GHz)	2.55 dB

3 GENERAL INFORMATION

3.1 GENERAL DESCRIPTION OF EUT

PRODUCT	Wimax Router
MODEL NO.	MAX-200HW2
FCC ID	I88MAX200HW2
POWER SUPPLY	18Vdc from power adapter
MODULATION TECHNOLOGY	OFDMA
FREQUENCY RANGE	2496MHz ~ 2690MHz
CHANNEL BANDWIDTH	10MHz
NUMBER OF CHANNEL	18
MAX. EIRP POWER	31.86dBm
DATA CABLE	NA
I/O PORTS	LINE port *2 ETHERNET port *4
ASSOCIATED DEVICES	NA

NOTE:

1. This product is co-located with following certified 11g device:

Product Name	Brand	Model No.	FCC ID
802.11g wireless MiniPCI card	ZyXEL	ZyXEL G-620	I88G-620

2. For the EUT with modulation type and coding rate:

		DL	UL
Modulation		QPSK, 16QAM, 64QAM	QPSK, 16QAM
Code Rate	CC	1/2, 3/4, 2/3, 5/6	1/2, 3/4
	CTC	1/2, 3/4, 2/3, 5/6	1/2, 3/4
	Repetition	X2, x4, x6	X2, x4, x6

3. The above EUT information was declared by manufacturer and for more detailed features description, please refers to the manufacturer's specifications or User's Manual.



3.2 DESCRIPTION OF TEST MODES

Three channels have been tested and presented.

Low channel (L): 2501.0MHz.

Middle channel (M): 2587.5MHz.

High channel (H): 2685.0MHz.

3.2.1 TEST MODE APPLICABILITY AND TESTED CHANNEL DETAIL

EUT CONFIGURE MODE	APPLICABLE TO							DESCRIPTION
	OP	FS	EB	CE	CSE	RE<1G	RE ³ 1G	
-	√	√	√	√	√	√	√	-

Where **OP**: Output power
EB: Emission bandwidth
CSE: Conducted spurious emissions
RE³1G: Radiated emission above 1GHz
FS: Frequency stability
CE: Channel edge
RE<1G: Radiated emission below 1GHz

OUTPUT POWER MEASUREMENT:

- Pre-Scan has been conducted to determine the worst-case mode from all possible combinations between available modulations, data rates, and antenna ports (if EUT with antenna diversity architecture).
- Following channel(s) was (were) selected for the final test as listed below.

TESTED CHANNEL	MODULATION TECHNOLOGY	MODULATION TYPE
L, M, H	OFDMA	QPSK-1/2

FREQUENCY STABILITY MEASUREMENT:

- Pre-Scan has been conducted to determine the worst-case mode from all possible combinations between available modulations, data rates, and antenna ports (if EUT with antenna diversity architecture).
- Following channel(s) was (were) selected for the final test as listed below.

TESTED CHANNEL	MODULATION TECHNOLOGY	MODULATION TYPE
L	OFDMA	QPSK-1/2

EMISSION BANDWIDTH MEASUREMENT:

- Pre-Scan has been conducted to determine the worst-case mode from all possible combinations between available modulations, data rates, and antenna ports (if EUT with antenna diversity architecture).
- Following channel(s) was (were) selected for the final test as listed below.

TESTED CHANNEL	MODULATION TECHNOLOGY	MODULATION TYPE
L, M, H	OFDMA	QPSK-1/2



CHANNEL EDGE MEASUREMENT:

- Pre-Scan has been conducted to determine the worst-case mode from all possible combinations between available modulations, data rates, and antenna ports (if EUT with antenna diversity architecture).
- Following channel(s) was (were) selected for the final test as listed below.

TESTED CHANNEL	MODULATION TECHNOLOGY	MODULATION TYPE
L, M, H	OFDMA	QPSK-1/2

CONDUCTED SPURIOUS EMISSIONS MEASUREMENT:

- Pre-Scan has been conducted to determine the worst-case mode from all possible combinations between available modulations, data rates, and antenna ports (if EUT with antenna diversity architecture).
- Following channel(s) was (were) selected for the final test as listed below.

TESTED CHANNEL	MODULATION TECHNOLOGY	MODULATION TYPE
L, M, H	OFDMA	QPSK-1/2

RADIATED EMISSION MEASUREMENT (BELOW 1 GHz):

- Pre-Scan has been conducted to determine the worst-case mode from all possible combinations between available modulations, data rates, and antenna ports (if EUT with antenna diversity architecture).
- Following channel(s) was (were) selected for the final test as listed below.

TESTED CHANNEL	MODULATION TECHNOLOGY	MODULATION TYPE
H	OFDMA	QPSK-1/2

RADIATED EMISSION MEASUREMENT (ABOVE 1 GHz):

- Pre-Scan has been conducted to determine the worst-case mode from all possible combinations between available modulations, data rates, and antenna ports (if EUT with antenna diversity architecture).
- Following channel(s) was (were) selected for the final test as listed below.

TESTED CHANNEL	MODULATION TECHNOLOGY	MODULATION TYPE
L, M, H	OFDMA	QPSK-1/2



3.3 GENERAL DESCRIPTION OF APPLIED STANDARDS

The EUT is a RF product. According to the specifications of the manufacturer, it must comply with the requirements of the following standards:

FCC 47 CFR Part 2

FCC 47 CFR Part 27

ANSI C63.4-2003

ANSI/TIA/EIA-603-A

NOTE: All test items have been performed and recorded as per the above standards.

3.4 DESCRIPTION OF SUPPORT UNITS

The EUT has been tested as an independent unit together with other necessary accessories or support units. The following support units or accessories were used to form a representative test configuration during the tests.

NO.	PRODUCT	BRAND	MODEL NO.	SERIAL NO.	FCC ID
1	NOTEBOOK	DELL	PP18L	6976685584	FCC Doc
2	HUB	AVSYS	110H8	01-20E-000002	DoC
3	TELEPHONE	ROMEO	TE-812	97285638	N/A
4	TELEPHONE	DAISHO	DS-03	N/A	N/A

NO.	SIGNAL CABLE DESCRIPTION OF THE ABOVE SUPPORT UNITS
1	NA
2	NA
3	1.8 m Non shielded cable, RJ11 connector, w/o core.
4	1.8 m Non shielded cable, RJ11 connector, w/o core.

NOTE: All power cords of the above support units are non shielded (1.8m).

3.4.1 CONFIGURATION OF SYSTEM UNDER TEST

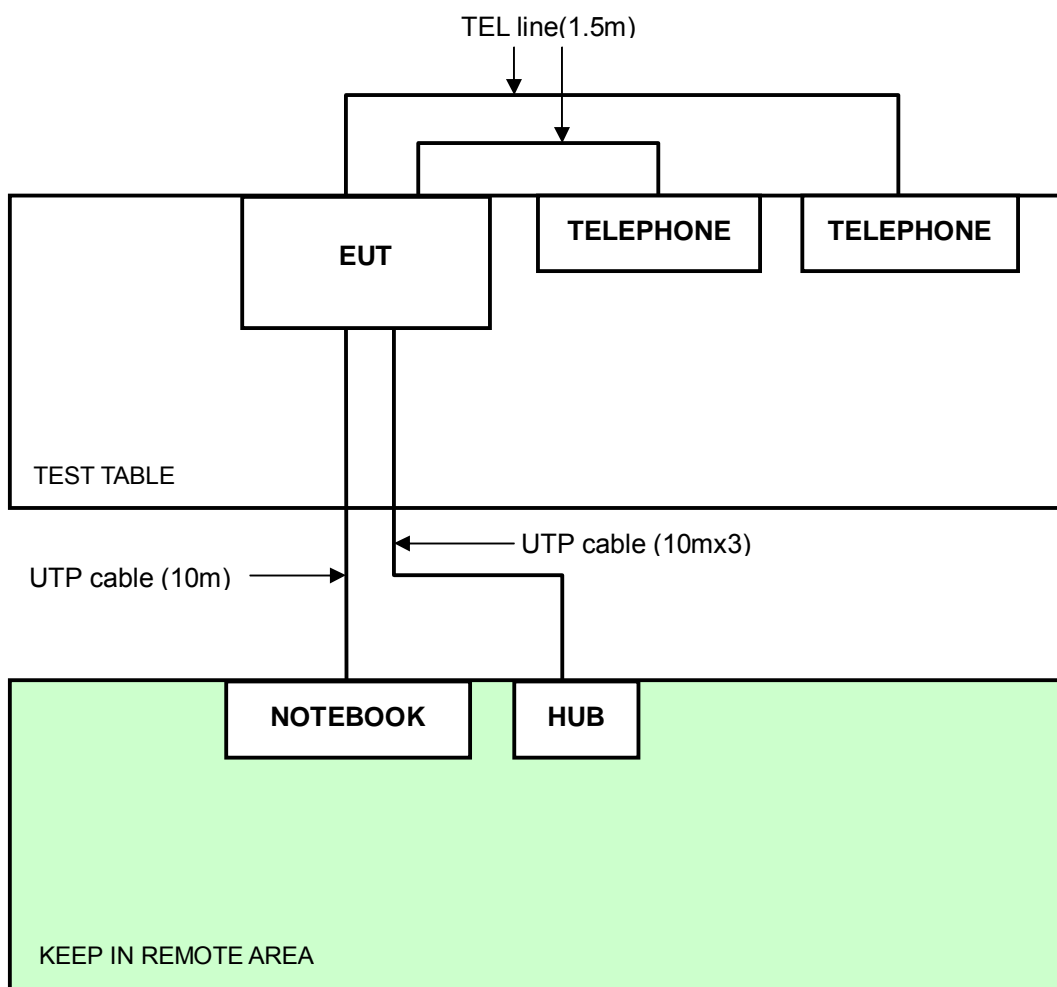

4 TEST TYPES AND RESULTS

4.1 OUTPUT POWER MEASUREMENT

4.1.1 LIMITS OF OUTPUT POWER MEASUREMENT

The radiated peak output power shall be according to the specific rule Part 27.50(h)(2) that “Mobile stations are limited to 2 watts e.i.r.p” and 27.50(i) specific that “Peak transmit power must be measure over any interval of continuous transmission using instrumentation calibration in terms of rms-equivalent voltage.”



4.1.2 TEST INSTRUMENTS

Description & Manufacturer	Model No.	Serial No.	Calibrated Until
Agilent Spectrum Analyzer	E4440A	MY46185282	Jun. 14, 2008
HUBER+SUHNER	SUCOFLEX104	22076614	Nov. 13, 2008
JFW 10dB attenuation	50HF-010-SMA	N/A	N/A

NOTE:

The calibration interval of the above test instruments is 12 months and the calibrations are traceable to NML/ROC and NIST/USA.

4.1.3 TEST PROCEDURES

For Conducted Power:

- a. The transmitter output was connected to the spectrum analyzer and measured with Spectrum Analyzer. All measurements were done at 3 channels: low, middle and high operational frequency range.
- b. Set span to encompass the entire emission bandwidth of the signal.
- c. Using the spectrum analyzer's channel power measurement function to measure the output power.
- d. The "Read Value" is the spectrum reading the maximum power value.

For EIRP Power:

- a. The EUT was placed on the top of a rotating table 0.8 meters above the ground. The table was rotated 360 degrees to determine the position of the highest radiation.
- b. The EUT was set 3 meters away from the receiving antenna, which was mounted on antenna tower and its position at 0.8 m above the ground.
- c. For each suspected emission, the EUT was arranged to its worst case and the rotatable table was turned from 0 degrees to 360 degrees to find the maximum reading and recorded the value.
- d. The EUT is replaced by a horn antenna connected to a signal generator tuned to the frequency of emission.
- e. The signal generator level has to be adjusted to have the same emission nature.
- f. The radiated power can be calculated via the factor and antenna gain.
- g. Repeat step a ~ f for horizontal polarization.

4.1.4 TEST SETUP

EIRP POWER MEASUREMENT:

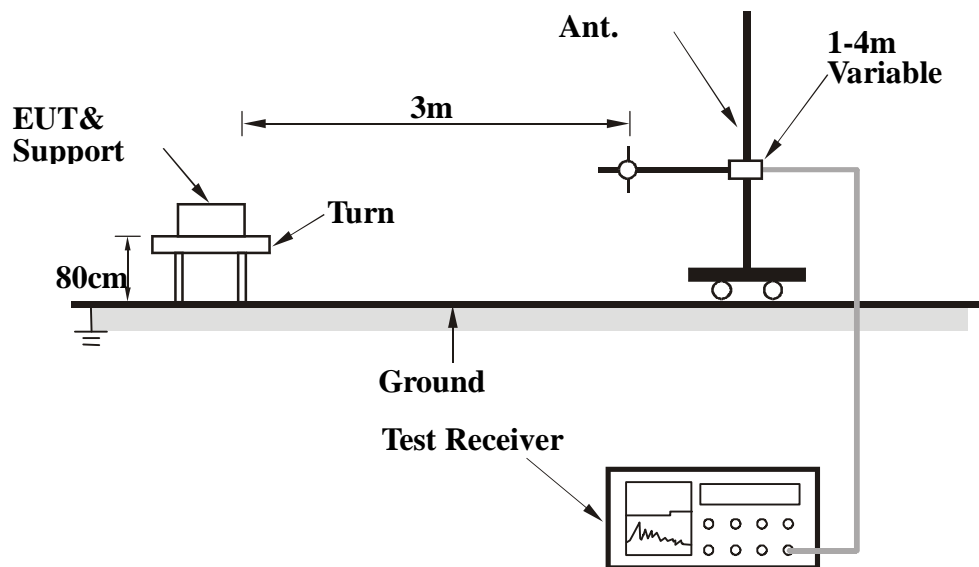

For the actual test configuration, please refer to the related item – Photographs of the Test Configuration.

CONDUCTED POWER MEASUREMENT:

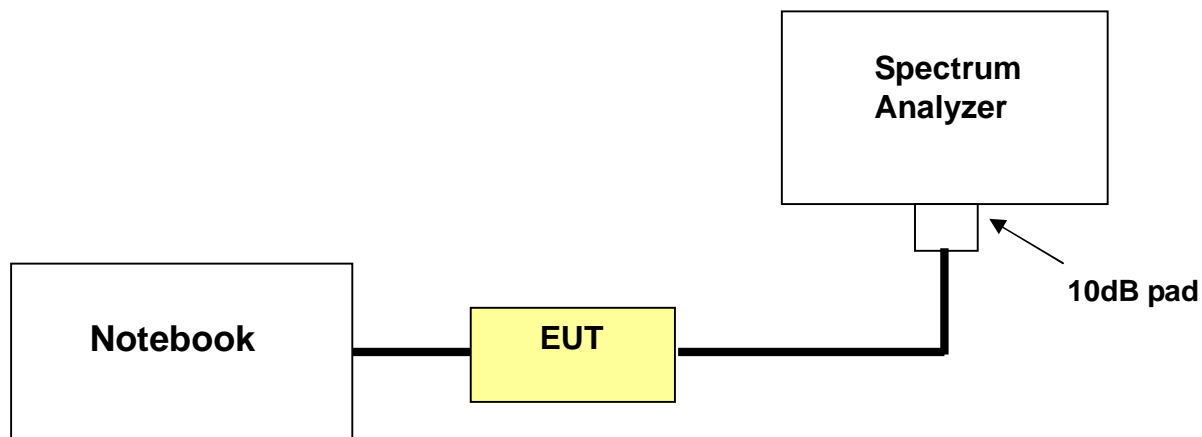

4.1.5 EUT OPERATING CONDITIONS

- a. The Notebook controlled EUT to export rated output power under transmission mode and specific channel frequency.

4.1.6 TEST RESULTS

INPUT POWER (SYSTEM)	120Vac, 60Hz	DETECTOR FUNCTION	RMS
ENVIRONMENTAL CONDITIONS	20deg°C, 60%RH 966hPa	TESTED BY	Wen Yu

EIRP POWER						
ANTENNA POLARITY & TEST DISTANCE: HORIZONTAL AT 3 M						
No.	Freq. (MHz)	Emission Level (dBuV/m)	Limit (dBm)	S.G level (dBm)	C.F. (dB)	Power level (dBm)
1	2501.00	112.38	33.00	10.49	6.65	17.14
2	2587.50	113.06	33.00	11.05	6.65	17.70
3	2685.00	112.69	33.00	10.71	6.65	17.36
ANTENNA POLARITY & TEST DISTANCE: VERTICAL AT 3 M						
No.	Freq. (MHz)	Emission Level (dBuV/m)	Limit (dBm)	S.G level (dBm)	C.F. (dB)	Power level (dBm)
1	2501.00	126.94	33.00	25.05	6.65	31.70
2	2587.50	127.22	33.00	25.21	6.65	31.86
3	2685.00	127.06	33.00	25.08	6.65	31.73

REMARKS: 1. Power Value(dBm)=S.G Power Value (dBm) + Correction Factor(dB)

CONDUCTED POWER			
CHANNEL	FREQUENCY (MHz)	PEAK POWER OUTPUT(mW)	PEAK POWER OUTPUT(dBm)
Low	2501.0	220.800	23.44
Middle	2587.5	256.448	24.09
High	2685.0	225.944	23.54



4.2 FREQUENCY STABILITY MEASUREMENT

4.2.1 LIMITS OF FREQUENCY STABILITY MEASUREMENT

According to the FCC part 2.1055 shall be tested the frequency stability. The rule is defined that "The frequency stability shall be sufficient to ensure that the fundamental emission stays within the authorized frequency block." The test extreme voltage is according to the 2.1055(d)(1) Vary primary supply voltage from 85 to 115 percent of the nominal value for other than hand carried battery equipment and the extreme temperature rule is comply with specification of EUT $-20^{\circ}\text{C} \sim 45^{\circ}\text{C}$.

4.2.2 TEST INSTRUMENTS

DESCRIPTION & MANUFACTURER	MODEL NO.	SERIAL NO.	CALIBRATED UNTIL
R&S SPECTRUM ANALYZER	FSP40	100037	Aug. 12, 2008
OVEN	MHU-225AU	911033	Dec. 04, 2008
HUBER+SUHNER	SUCOFLEX104	22076614	Nov. 13, 2008
AC POWER SOURCE	6205	1140503	N/A

NOTE: 1. The calibration interval of the above test instruments is 12 months. And the calibrations are traceable to NML/ROC and NIST/USA.

4.2.3 TEST PROCEDURE

- a. Power must be removed when changing from one temperature to another or one voltage to another voltage. Power warm up is at least 15 min and power applied should perform before recording frequency error.
- b. EUT is connected the external power supply to control the DC input power. The various Volts from the minimum 102 Volts to 138 Volts. Each step shall be record the frequency error rate.
- c. The temperature range step is 10 degrees in this test items. All temperature levels shall be hold the $\pm 0.5^{\circ}\text{C}$ during the measurement testing.
- d. The each temperature step shall be at least 0.5 hours, consider the EUT could be test under the stability condition.

4.2.4 TEST SETUP

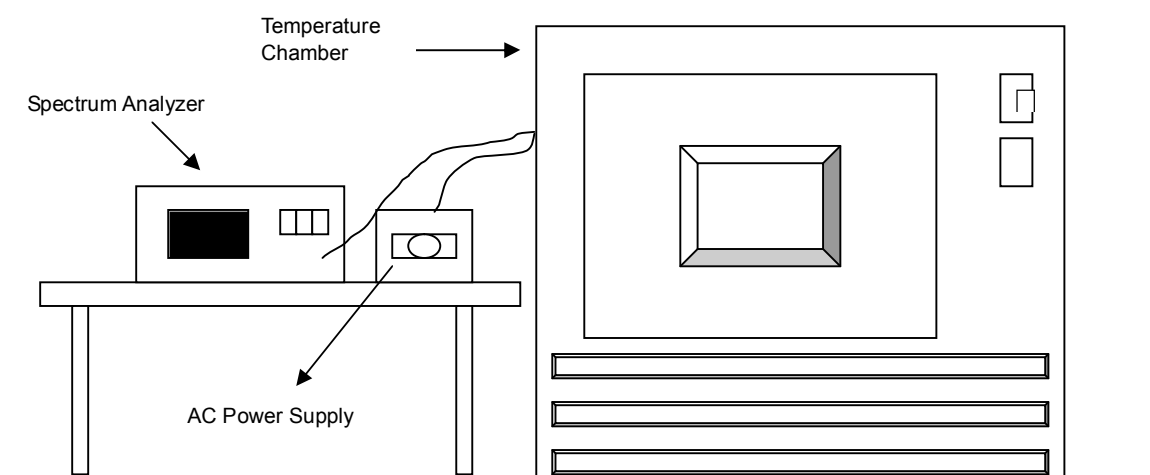



4.2.5 TEST RESULTS

MODE	High channel (2685.0MHz)	INPUT POWER (SYSTEM)	120Vac, 60Hz
ENVIRONMENTAL CONDITIONS	20deg°C, 60%RH 966hPa	TESTED BY	Wen Yu

AFC FREQUENCY ERROR VS. VOLTAGE		
VOLTAGE (Volts)	FREQUENCY (MHz)	FREQUENCY DRIFT (ppm)
108	2684.9943	-2.123
120	2684.9973	-1.005
132	2684.9971	-1.08



MODE	High channel (2685.0MHz)	INPUT POWER (SYSTEM)	120Vac, 60Hz
ENVIRONMENTAL CONDITIONS	20deg°C, 60%RH 966hPa	TESTED BY	Wen Yu

AFC FREQUENCY ERROR VS. TEMP.		
TEMP. (°C)	FREQUENCY (MHz)	FREQUENCY DRIFT (ppm)
45	2684.9981	-0.708
40	2684.9979	-0.782
30	2684.9978	-0.819
20	2684.9973	-1.006
10	2684.9971	-1.080
0	2684.9969	-1.155
-10	2684.9937	-2.346
-20	2684.9919	-3.017

4.3 EMISSION BANDWIDTH MEASUREMENT

4.3.1 LIMITS OF EMISSION BANDWIDTH MEASUREMENT

According to FCC 27.53(l)(6) specified that emission bandwidth is defined as the width of the signal between two points, one below the carrier center frequency and one above the carrier center frequency, outside of which all emissions are attenuated at least 26dB below the transmitter power.

4.3.2 TEST INSTRUMENTS

DESCRIPTION & MANUFACTURER	MODEL NO.	SERIAL NO.	CALIBRATED UNTIL
Agilent Spectrum Analyzer	E4440A	MY46185282	Jun.14,2008
HUBER+SUHNER	SUCOFLEX104	22076614	Nov. 13, 2008
JFW 10dB attenuation	50HF-010-SMA	NA	NA

NOTE: 1. The calibration interval of the above test instruments is 12 months. And the calibrations are traceable to NML/ROC and NIST/USA.

4.3.3 TEST SETUP

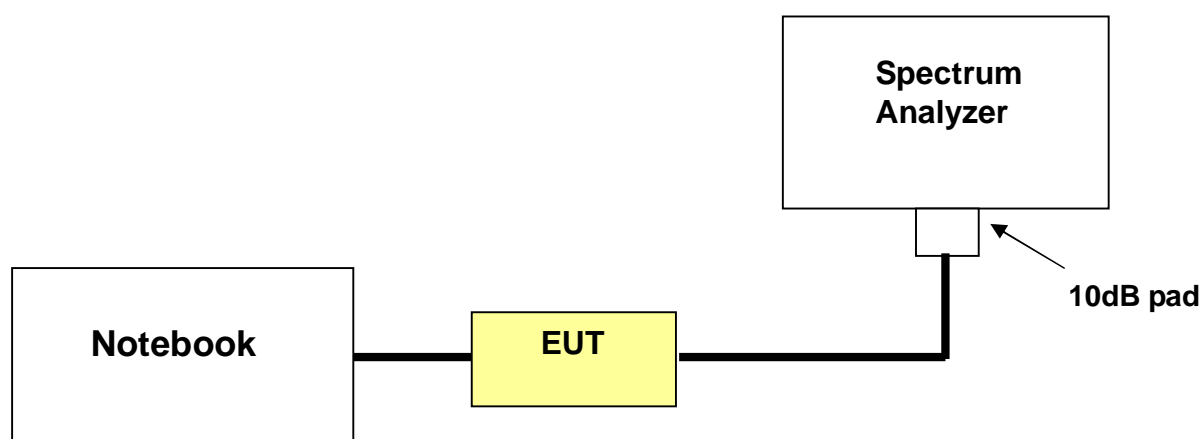

4.3.4 TEST PROCEDURES

- a. The Notebook controlled EUT to export rated output power under transmission mode and specific channel frequency. FCC 27.53(l)(6) required a measurement bandwidth is the fundamental emission below 26dB bandwidth.

4.3.5 TEST RESULTS

FREQUENCY (MHz)	-26 dBc BANDWIDTH (MHz)
2501.0	8.9595
2587.5	8.9991
2685.0	9.0755

LOW CHANNEL

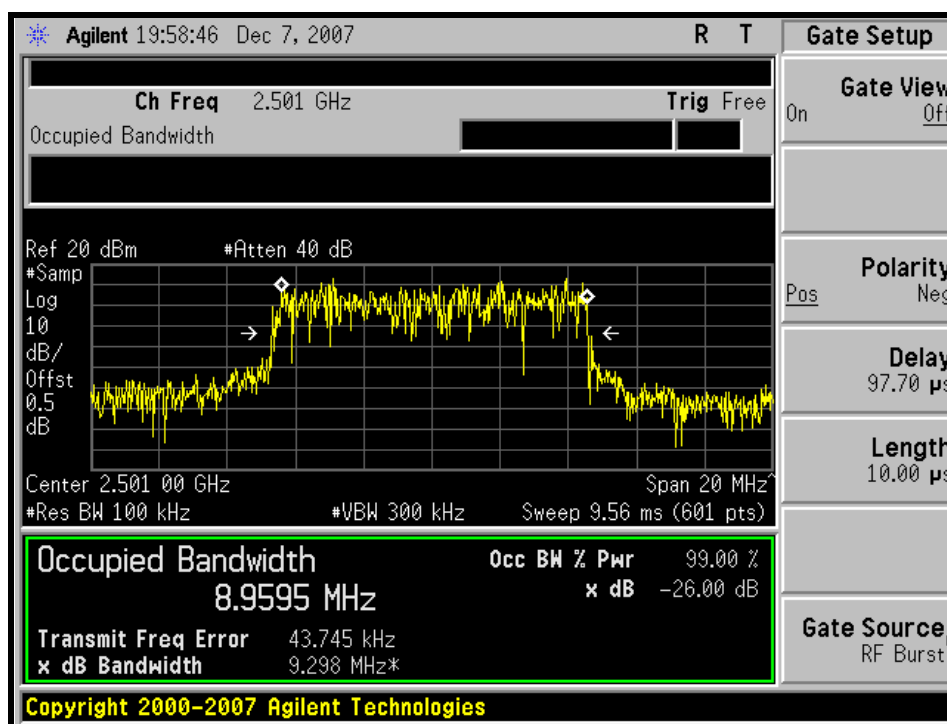

MIDDLE CHANNEL

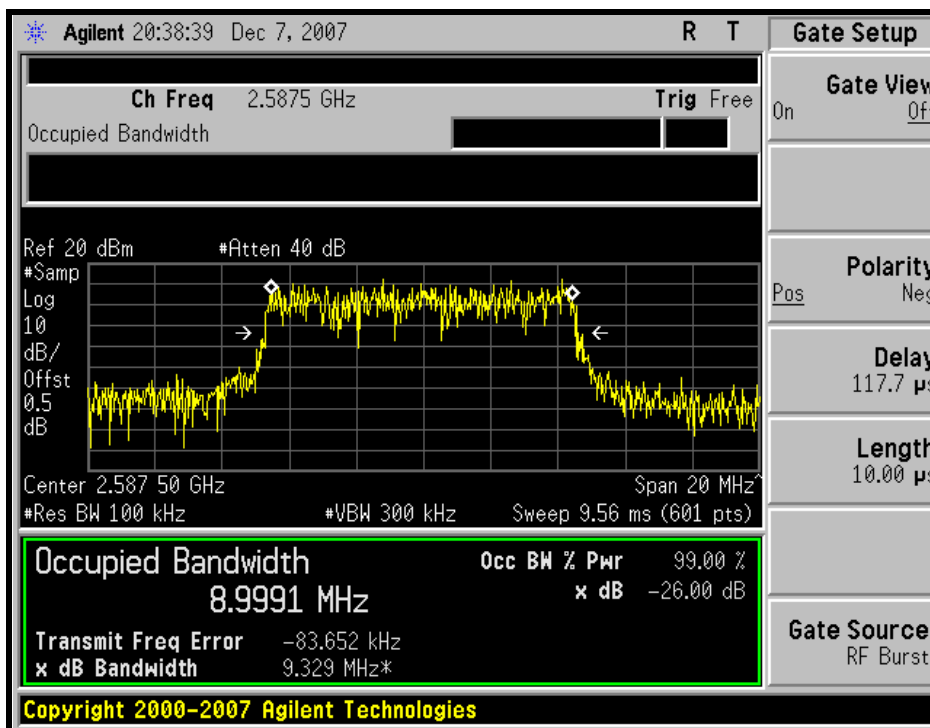

HIGH CHANNEL

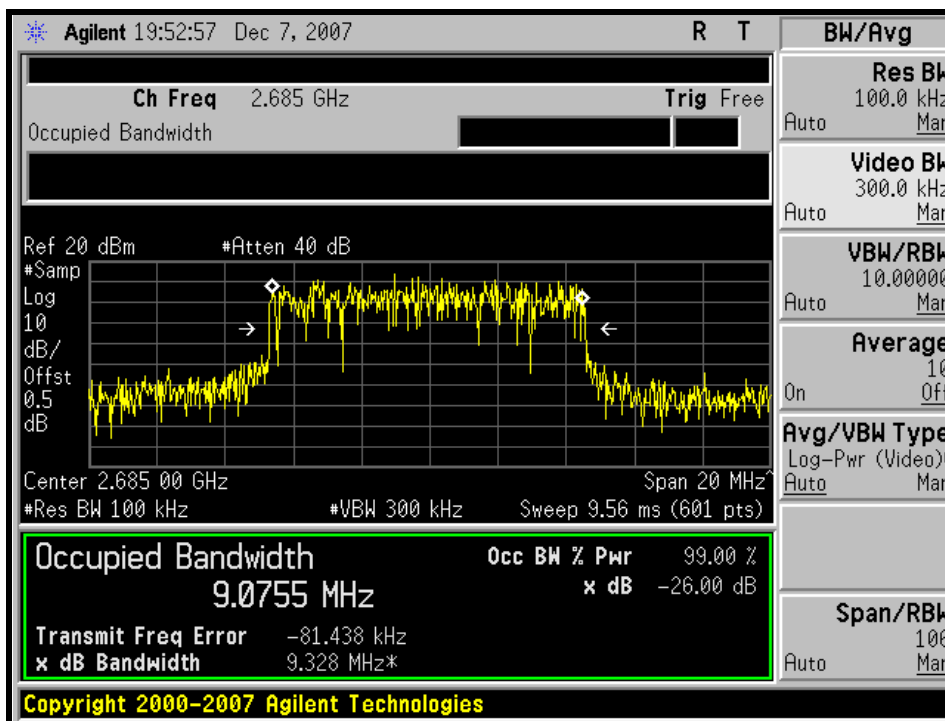



4.4 CHANNEL EDGE MEASUREMENT

4.4.1 LIMITS OF CHANNEL EDGE MEASUREMENT

According to FCC 27.53(l)(4) specified that power of any emission outside of the channel edge must be attenuated below the transmitting power (P) by a factor of at least $43 + 10 \log(P)$ dB. The specified minimum attenuation becomes 43dB and the limit of emission equal to -13 dBm. In the 1MHz bands immediately outside and adjacent to the frequency block a resolution bandwidth of at least one percent of the emission bandwidth of the fundamental emission of the transmitter may be employed.

4.4.2 TEST INSTRUMENTS

Agilent Spectrum Analyzer	E4440A	MY46185282	Jun. 14, 2008
HUBER+SUHNER	SUCOFLEX104	22076614	Nov. 13, 2008
JFW 10dB attenuation	50HF-010-SMA	NA	NA

NOTE: 1. The calibration interval of the above test instruments is 12 months. And the calibrations are traceable to NML/ROC and NIST/USA.

4.4.3 TEST SETUP

Same as Item 4.3.3

4.4.4 TEST PROCEDURES

- a. The EUT was set up for the rated peak power . The power was measured with Spectrum Analyzer. All measurements were done at 3 channels: low, middle and high operational frequency range.
- b. The center frequency of spectrum is the channel center frequency and span is 20MHz. RB of the spectrum is 100kHz and VB of the spectrum is 300kHz.
- c. Record the max trace plot into the test report.

4.4.5 EUT OPERATING CONDITION

- a. The Notebook controlled EUT to export rated output power under transmission mode and specific channel frequency.

4.4.6 TEST RESULTS

LOW CHANNEL

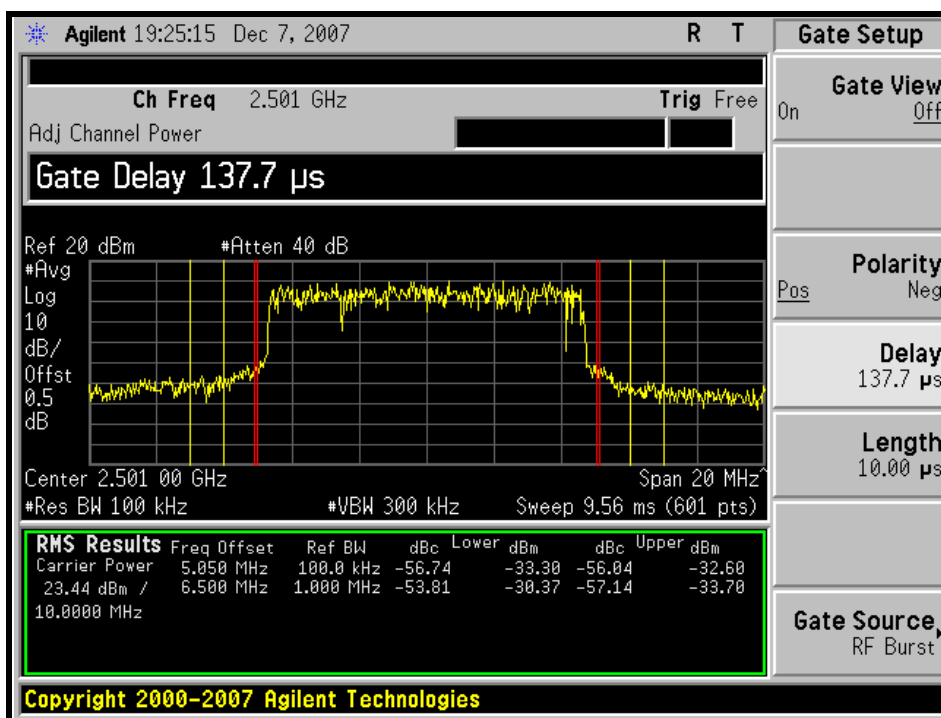

MIDDLE CHANNEL

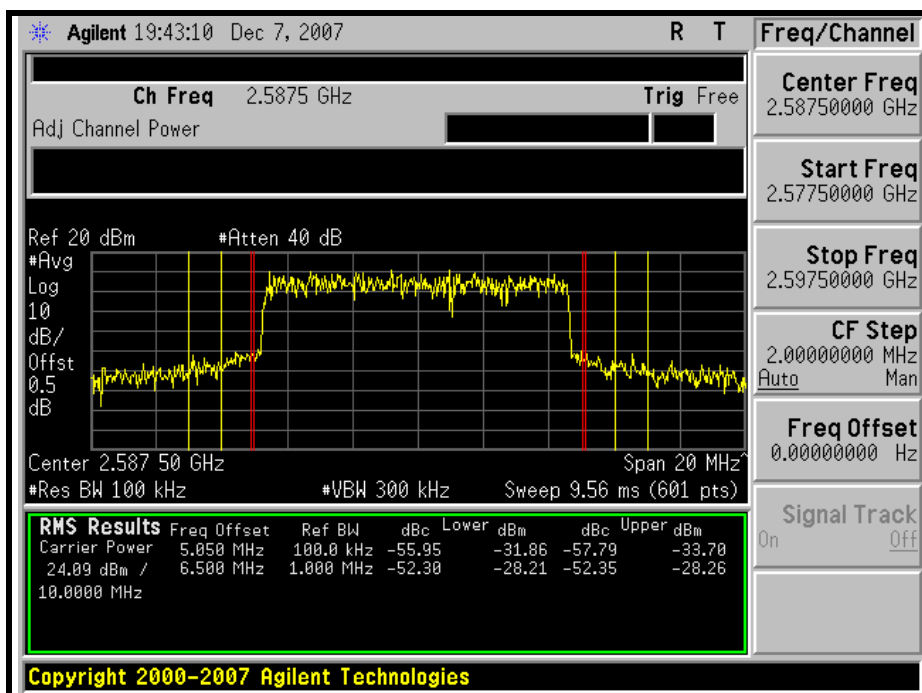

HIGH CHANNEL

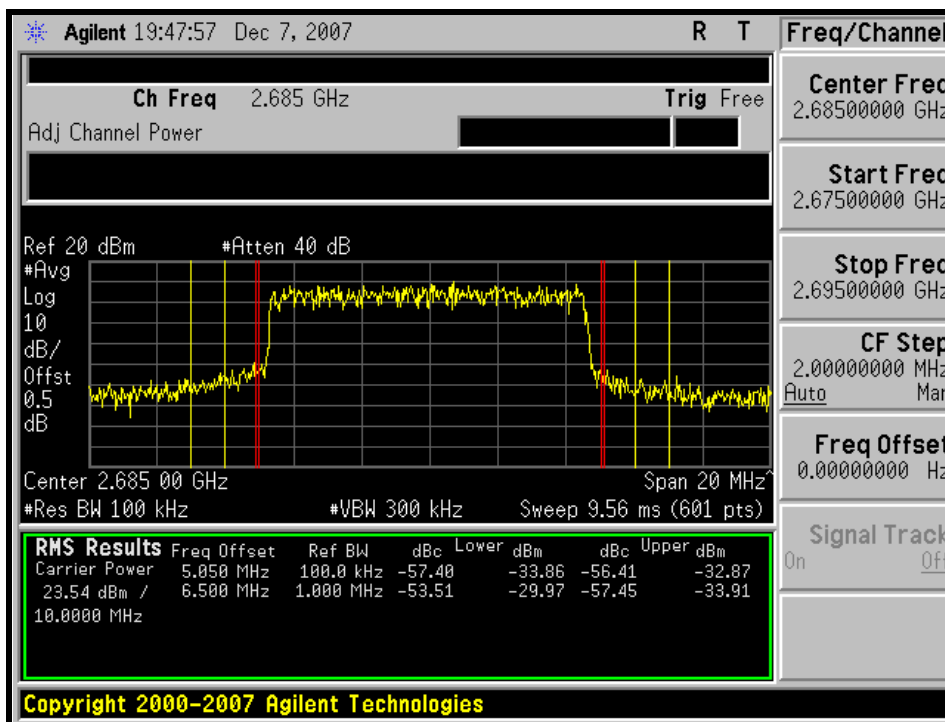



4.5 CONDUCTED SPURIOUS EMISSIONS

4.5.1 LIMITS OF CONDUCTED SPURIOUS EMISSIONS MEASUREMENT

In the FCC 27.53(l)(4), On any frequency outside a licensee's frequency block, the power of any emission shall be attenuated below the transmitter power (P) by at least $43 + 10 \log (P)$ dB. The specified minimum attenuation becomes 43dB and the limit of emission equal to -13 dBm.

4.5.2 TEST INSTRUMENTS

DESCRIPTION & MANUFACTURER	MODEL NO.	SERIAL NO.	CALIBRATED UNTIL
Agilent Spectrum Analyzer	E4440A	MY46185282	Jun. 14, 2008
HUBER+SUHNER	SUCOFLEX104	22076614	Nov. 13, 2008
JFW 10dB attenuation	50HF-010-SMA	NA	NA
Wainwright Instruments High Pass Filter	WHK3.1/18G-10SS	ZZ-010091	NA

NOTE: 1. The calibration interval of the above test instruments is 12 months. And the calibrations are traceable to NML/ROC and NIST/USA.

4.5.3 TEST PROCEDURE

- a. The EUT was set up for the rated peak power. The power was measured with Spectrum Analyzer. All measurements were done at 3 channels: low, middle and high operational frequency range.
- b. When the spectrum scanned from 30MHz to 3GHz, it shall be connected to the 10dB pad attenuated the carried frequency. The spectrum set RB = 1MHz, VB = 3MHz.
- c. When the spectrum scanned from 3GHz to 27GHz, it shall be connected to the high pass filter attenuated the carried frequency. The spectrum set RB = 1MHz, VB = 3MHz.

4.5.4 TEST SETUP

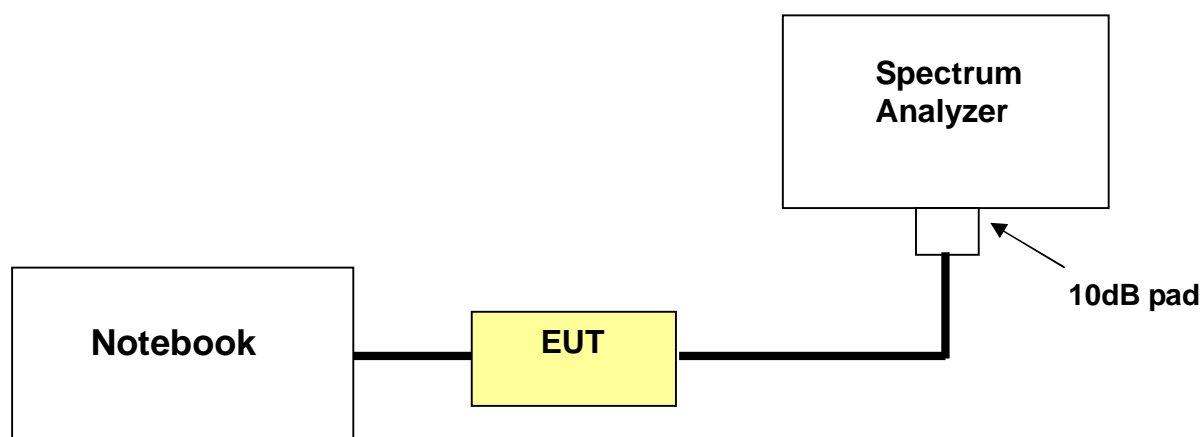

4.5.5 EUT OPERATING CONDITIONS

- a. The Notebook controlled EUT to export rated output power under transmission mode and specific channel frequency.

4.5.6 TEST RESULTS

LOW CHANNEL: 30MHz ~ 1GHz:

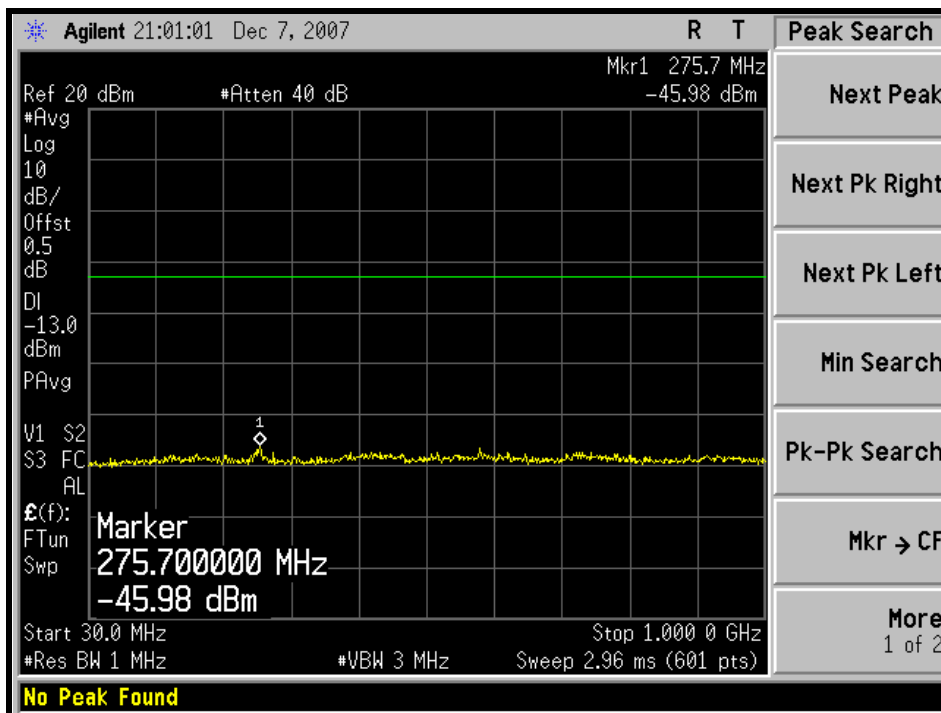

1GHz ~ 5GHz:

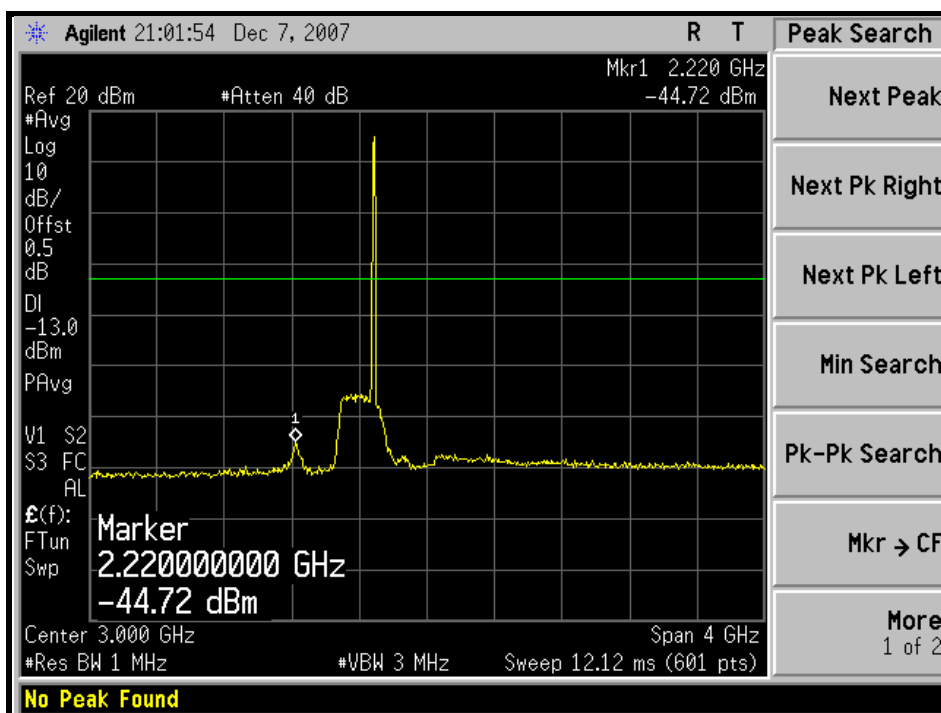

5GHz ~ 10GHz:

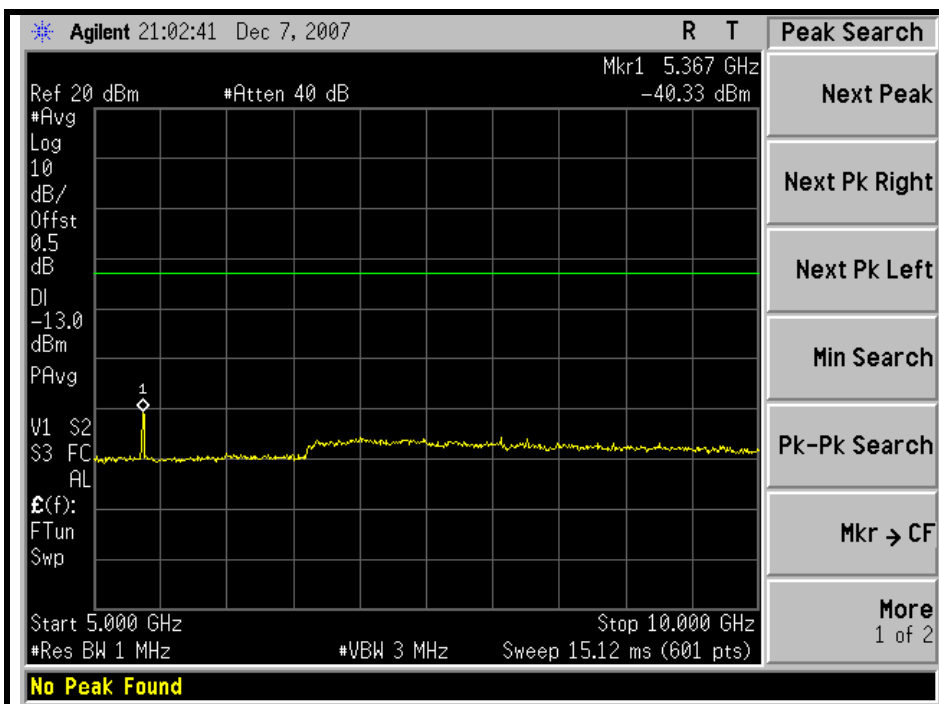

10GHz ~ 26.5GHz:

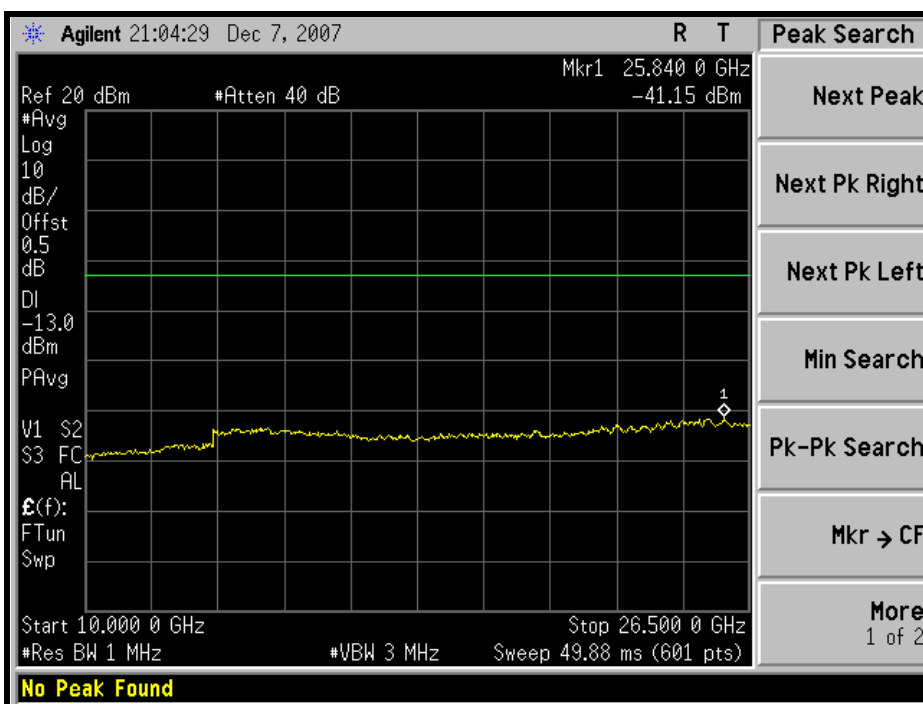

MIDDLE CHANNEL: 30MHz ~ 1GHz:

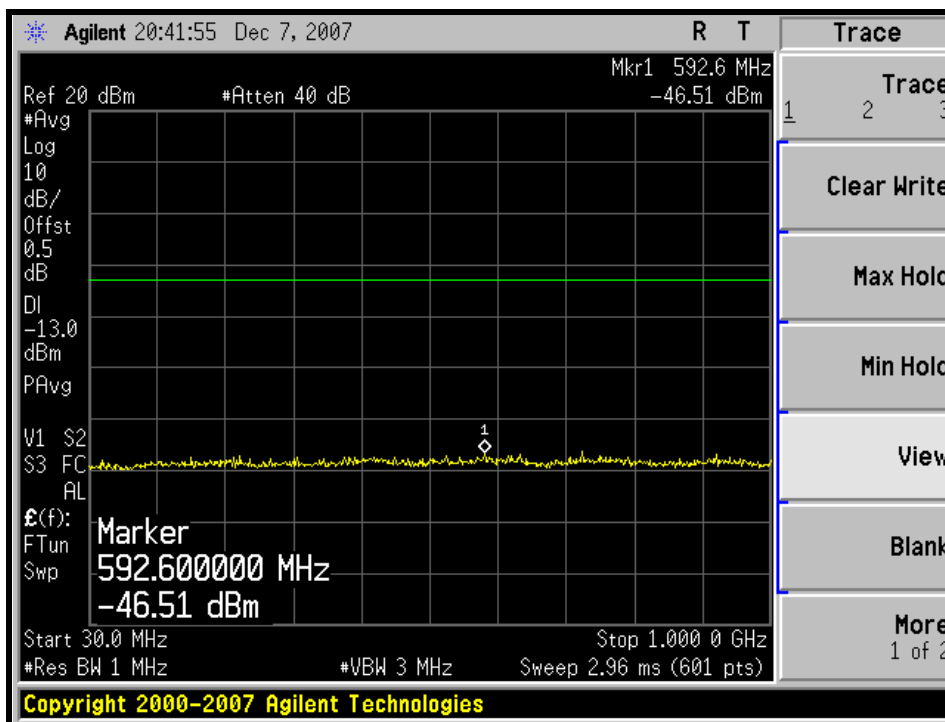

1GHz ~ 5GHz:

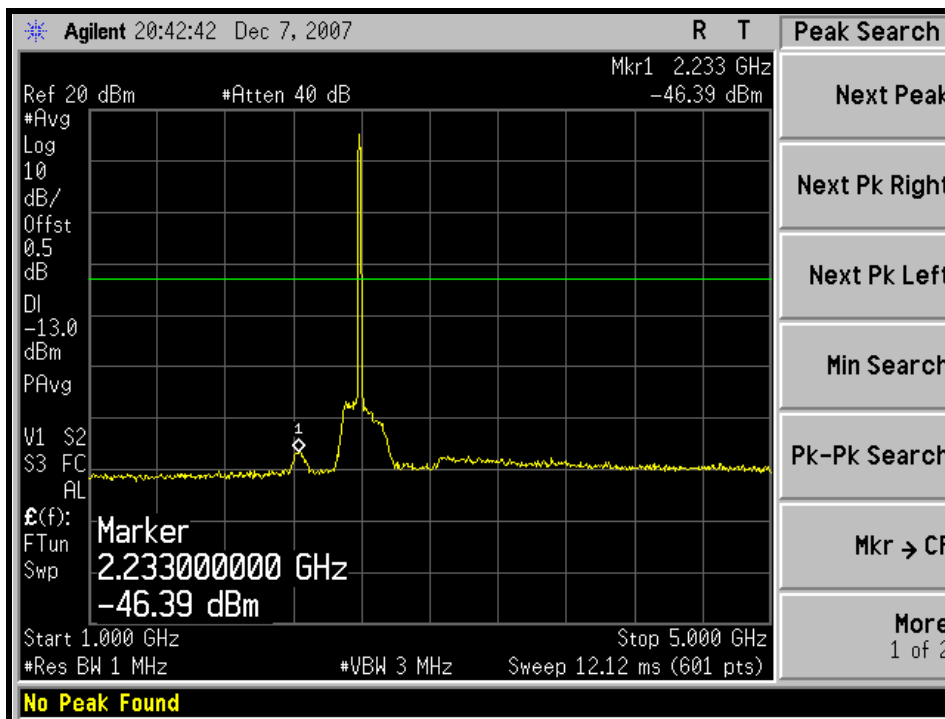

5GHz ~ 10GHz:

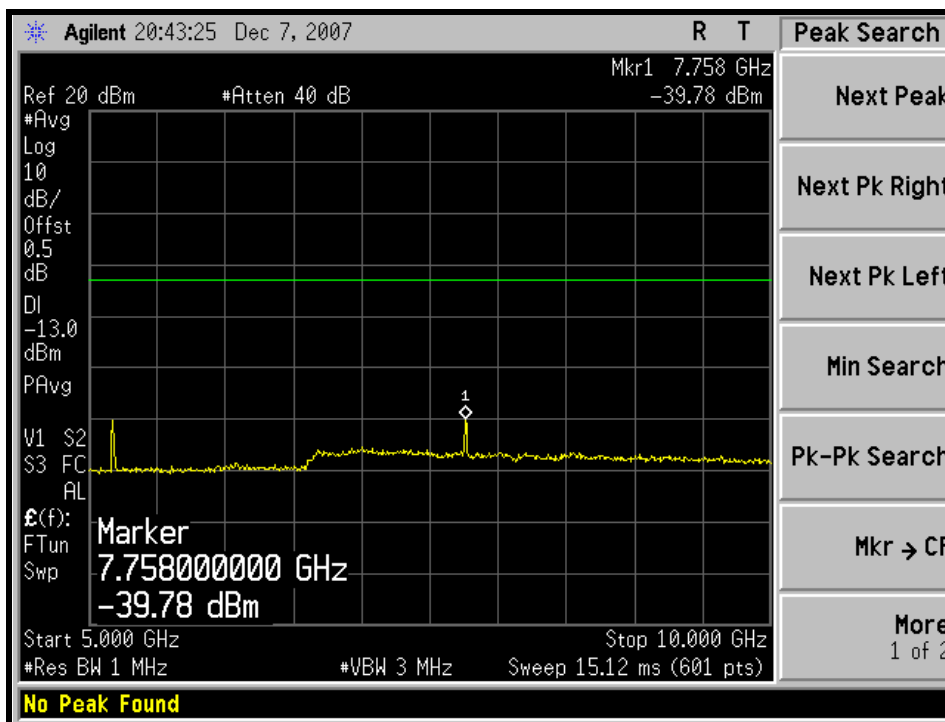

10GHz ~ 26.5GHz:

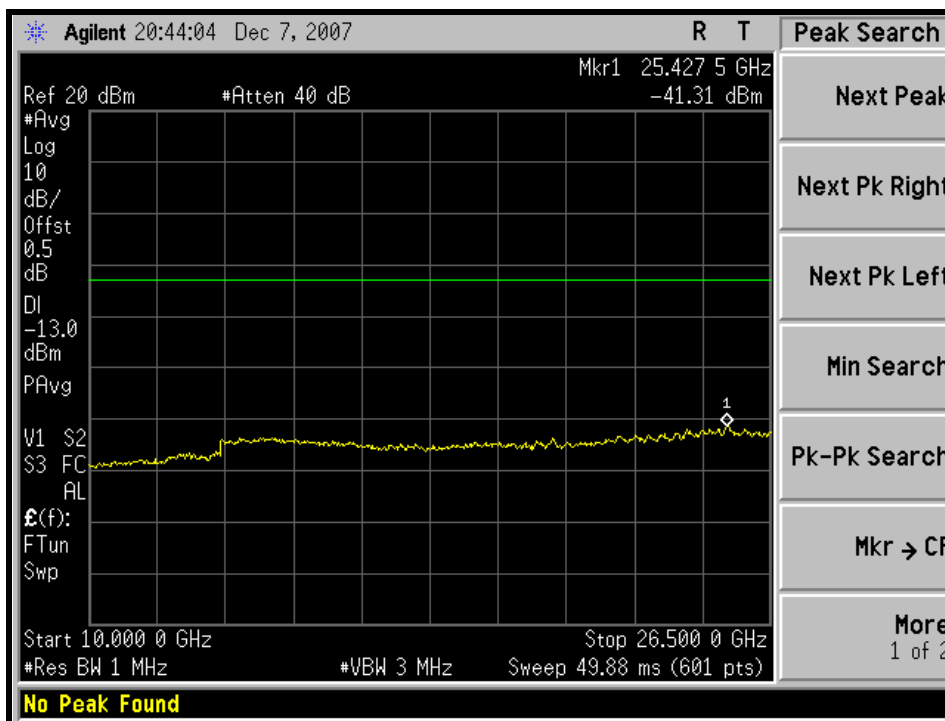

HIGH CHANNEL: 30MHz ~ 1GHz:

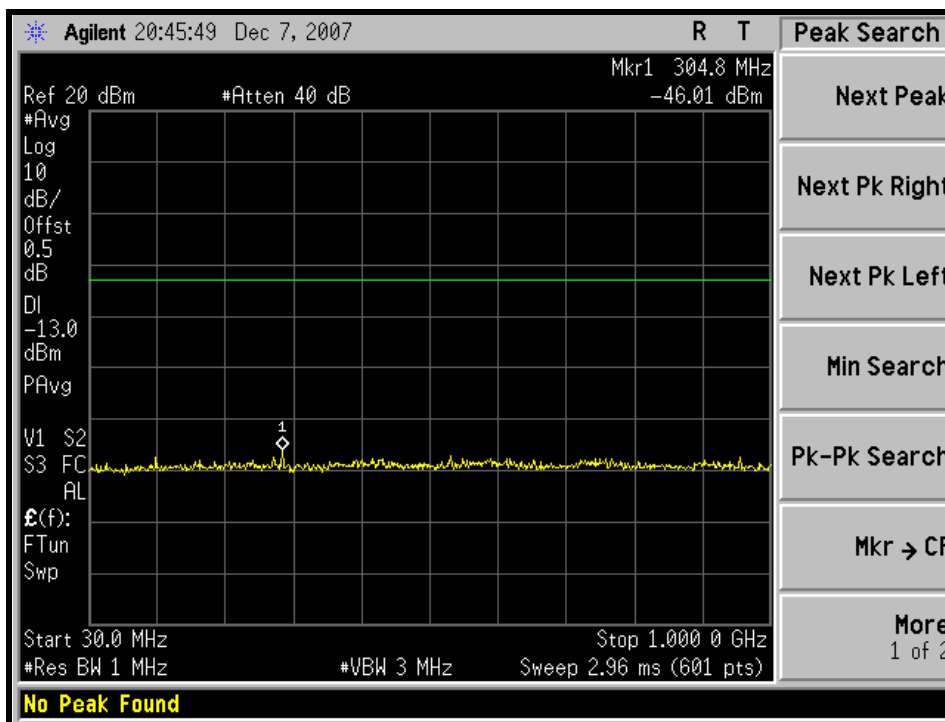

1GHz ~ 5GHz:

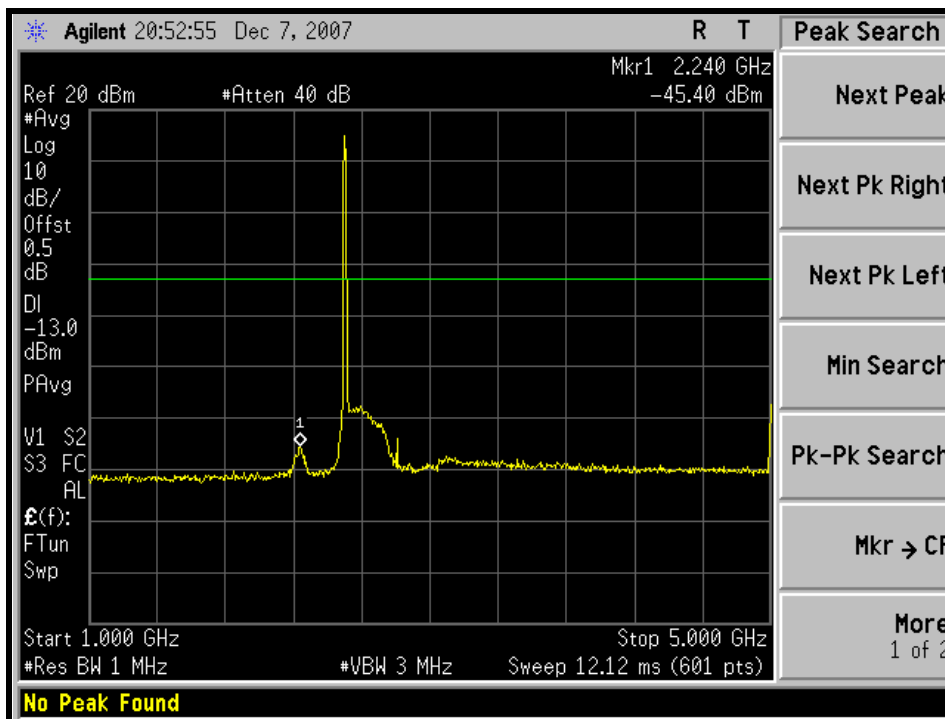

5GHz ~ 10GHz:

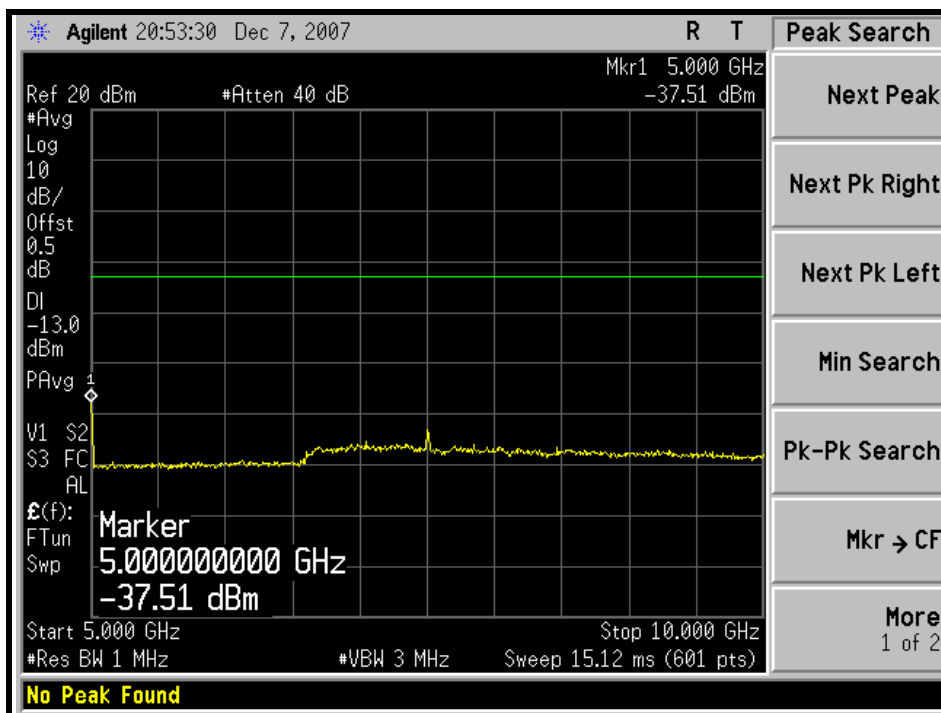

10GHz ~ 26.5GHz:

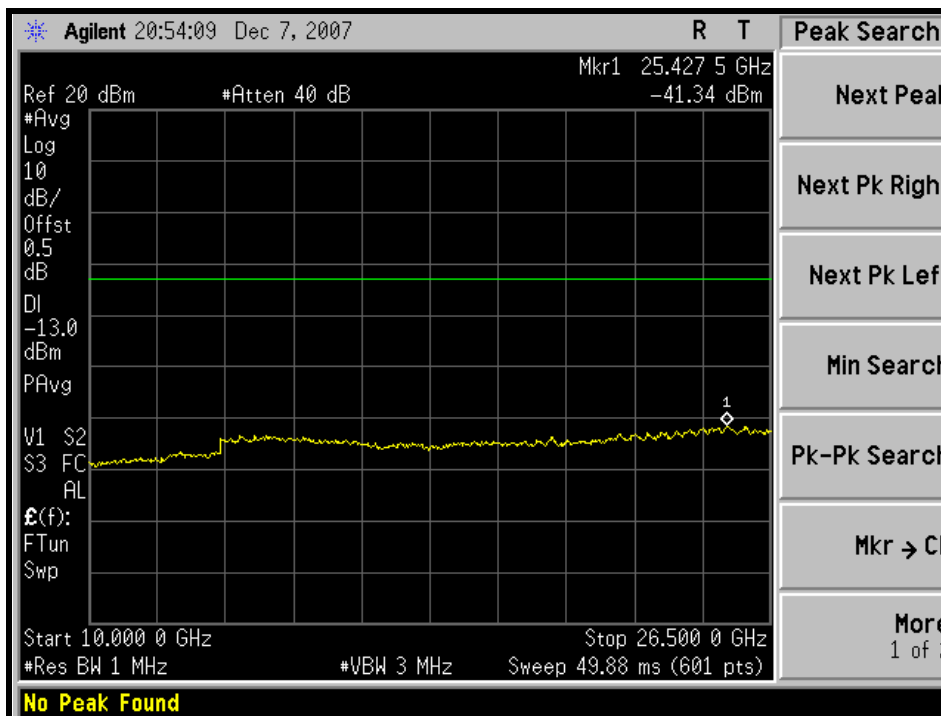

4.6 RADIATED EMISSION MEASUREMENT (BELOW 1GHz)

4.6.1 LIMITS OF RADIATED EMISSION MEASUREMENT

In the FCC 27.53(l) (4), On any frequency outside a licensee's frequency block the power of any emission shall be attenuated below the transmitter power (P) by at least $43 + 10 \log (P)$ dB. The specified minimum attenuation becomes 43dB and the limit of emission equal to -13 dBm.



4.6.2 TEST INSTRUMENTS

DESCRIPTION & MANUFACTURER	MODEL NO.	SERIAL NO.	CALIBRATED UNTIL
ADVANTEST Spectrum Analyzer	R3271A	85060311	July 15, 2008
HP Pre_Amplifier	8449B	3008A01922	Oct. 04, 2008
ROHDE & SCHWARZ Test Receiver	ESCS30	100375	Mar. 26, 2008
CHASE Broadband Antenna	VULB 9168	138	July 26, 2008
Schwarzbeck Horn_Antenna	BBHA9120	D124	Jan. 01, 2008
Schwarzbeck Horn_Antenna	BBHA 9170	BBHA9170153	Jan. 25, 2008
TRILOG Broad Band Antenna	VULB 9168	138	July 26, 2008
RF Switches (ARNITSU)	CS-201	1565157	Aug. 13, 2008
RF CABLE (Chaintek)	SF102	22054-2	Nov. 14. 2008
RF Cable(RICHTEC)	9913-30M N-N Cable	STCCAB-30M-1 GHz	Aug. 13, 2008
Software	ADT_Radiated_V 7.6.15.7	NA	NA
CHANCE MOST Antenna Tower	AT-100	0203	NA
CHANCE MOST Turn Table	TT-100	0203	NA

- Note: 1. The calibration interval of the above test instruments is 12 months and the calibrations are traceable to NML/ROC and NIST/USA.
2. The horn antenna, HP preamplifier (model: 8449B) and Spectrum Analyzer (model: R3271A) are used only for the measurement of emission frequency above 1GHz if tested.
3. The test was performed in ADT Open Site No. C.
4. The FCC Site Registration No. is 656396.
5. The VCCI Site Registration No. is R-1626.
6. The CANADA Site Registration No. is IC 4824A-3.

4.6.3 TEST PROCEDURES

- a. The EUT was placed on the top of a rotating table 0.8 meters above the ground. The table was rotated 360 degrees to determine the position of the highest radiation.
- b. The EUT was set 3 meters away from the receiving antenna, which was mounted on antenna tower and its position at 0.8 m above the ground.
- c. For each suspected emission, the EUT was arranged to its worst case and the rotatable table was turned from 0 degrees to 360 degrees to find the maximum reading and recorded the value.
- d. The EUT is replaced by a horn antenna connected to a signal generator tuned to the frequency of emission.
- e. The signal generator level has to be adjusted to have the same emission nature.
- f. The radiated power can be calculated via the factor and antenna gain.
- g. Repeat step a ~ f for horizontal polarization.

NOTE: The resolution bandwidth of spectrum analyzer is 1MHz and the video bandwidth is 3MHz.

4.6.4 DEVIATION FROM TEST STANDARD

No deviation

4.6.5 TEST SETUP

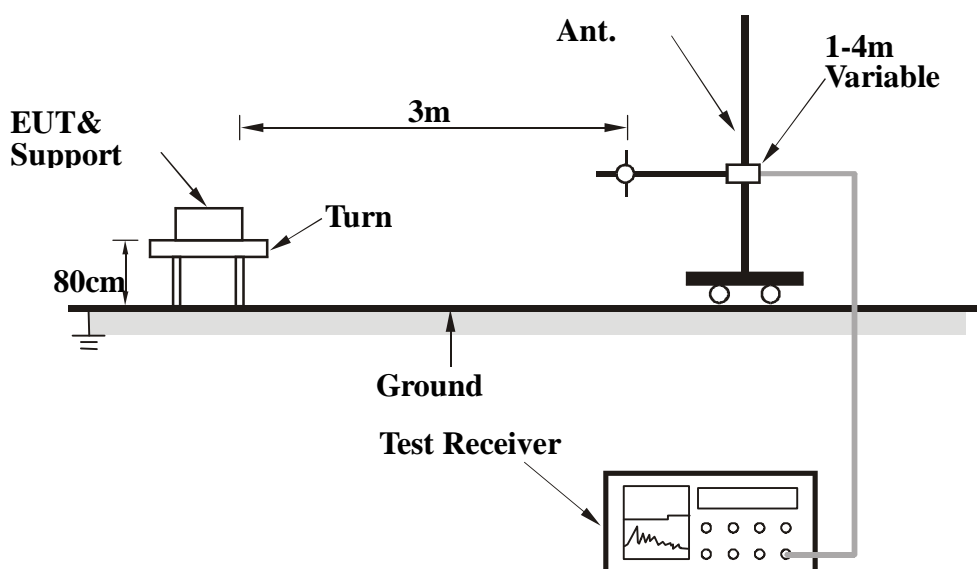

For the actual test configuration, please refer to the related item – Photographs of the Test Configuration.

4.6.6 EUT OPERATING CONDITIONS

- a. The Notebook controlled EUT to export rated output power under transmission mode and specific channel frequency.

4.6.7 TEST RESULTS

MODE	High channel	FREQUENCY RANGE	Below 1000MHz
INPUT POWER (SYSTEM)	120Vac, 60Hz	ENVIRONMENTAL CONDITIONS	18deg°C, 71%RH 966hPa
TESTED BY	Sky Liao		

ANTENNA POLARITY & TEST DISTANCE: HORIZONTAL AT 3 M						
No.	Freq. (MHz)	Power level (dBm)	Limit (dBm)	S.G level (dBm)	C.F. (dB)	Emission Level (dBuV/m)
1	133.33	-59.86	-13.00	-60.494	0.634	35.44
2	200.00	-62.94	-13.00	-68.905	5.965	32.66
3	266.67	-58.88	-13.00	-64.763	5.883	36.52
4	400.00	-57.40	-13.00	-47.885	-9.515	38.3
5	500.00	-59.18	-13.00	-49.646	-9.534	36.02
6	533.33	-52.30	-13.00	-42.878	-9.422	43.1
7	600.00	-60.11	-13.00	-50.63	-9.48	36.09
8	700.00	-62.84	-13.00	-53.215	-9.625	33.66
9	800.00	-56.58	-13.00	-46.936	-9.644	38.62
10	933.33	-58.09	-13.00	-48.254	-9.836	37.71

ANTENNA POLARITY & TEST DISTANCE: VERTICAL AT 3 M						
No.	Freq. (MHz)	Power level (dBm)	Limit (dBm)	S.G level (dBm)	C.F. (dB)	Emission Level (dBuV/m)
1	110.00	-69.78	-13.00	-70.491	0.711	25.82
2	200.00	-64.93	-13.00	-70.895	5.965	30.27
3	233.33	-69.49	-13.00	-75.272	5.782	25.81
4	330.00	-64.92	-13.00	-70.634	5.714	30.58
5	400.00	-58.08	-13.00	-48.565	-9.515	37.12
6	600.00	-62.01	-13.00	-52.53	-9.48	33.39
7	700.00	-64.86	-13.00	-55.235	-9.625	30.64
8	800.00	-57.67	-13.00	-48.026	-9.644	37.53

REMARKS: 1. Power Value(dBm)=S.G Power Value (dBm) + Correction Factor(dB)



4.7 RADIATED EMISSION MEASUREMENT (ABOVE 1GHz)

4.7.1 LIMITS OF RADIATED EMISSION MEASUREMENT

In the FCC 27.53(l) (4), On any frequency outside a licensee's frequency block, the power of any emission shall be attenuated below the transmitter power (P) by at least $43 + 10 \log (P)$ dB. The specified minimum attenuation becomes 43dB and the limit of emission equal to -13 dBm.



4.7.2 TEST INSTRUMENTS

DESCRIPTION & MANUFACTURER	MODEL NO.	SERIAL NO.	CALIBRATED UNTIL
ADVANTEST Spectrum Analyzer	R3271A	85060311	July 15, 2008
HP Pre_Amplifier	8449B	3008A01922	Oct. 04, 2008
ROHDE & SCHWARZ Test Receiver	ESCS30	100375	Mar. 26, 2008
CHASE Broadband Antenna	VULB 9168	138	July 26, 2008
Schwarzbeck Horn_Antenna	BBHA9120	D124	Jan. 01, 2008
Schwarzbeck Horn_Antenna	BBHA 9170	BBHA9170153	Jan. 25, 2008
TRILOG Broad Band Antenna	VULB 9168	138	July 26, 2008
RF Switches (ARNITSU)	CS-201	1565157	Aug. 13, 2008
RF CABLE (Chaintek)	SF102	22054-2	Nov. 14. 2008
RF Cable(RICHTEC)	9913-30M N-N Cable	STCCAB-30M-1 GHz	Aug. 13, 2008
Software	ADT_Radiated_V 7.6.15.7	NA	NA
CHANCE MOST Antenna Tower	AT-100	0203	NA
CHANCE MOST Turn Table	TT-100	0203	NA

- Note: 1. The calibration interval of the above test instruments is 12 months and the calibrations are traceable to NML/ROC and NIST/USA.
2. The horn antenna, HP preamplifier (model: 8449B) and Spectrum Analyzer (model: R3271A) are used only for the measurement of emission frequency above 1GHz if tested.
3. The test was performed in ADT Open Site No. C.
4. The FCC Site Registration No. is 656396.
5. The VCCI Site Registration No. is R-1626.
6. The CANADA Site Registration No. is IC 4824A-3.

4.7.3 TEST PROCEDURES

- a. The EUT was placed on the top of a rotating table 0.8 meters above the ground. The table was rotated 360 degrees to determine the position of the highest radiation.
- b. The EUT was set 3 meters away from the receiving antenna, which was mounted on antenna tower and its position at 0.8 m above the ground.
- c. For each suspected emission, the EUT was arranged to its worst case and the rotatable table was turned from 0 degrees to 360 degrees to find the maximum reading and recorded the value.
- d. The EUT is replaced by a horn antenna connected to a signal generator tuned to the frequency of emission.
- e. The signal generator level has to be adjusted to have the same emission nature.
- f. The radiated power can be calculated via the factor and antenna gain.
- g. Repeat step a ~ f for horizontal polarization.

NOTE: The resolution bandwidth of spectrum analyzer is 1MHz and the video bandwidth is 3MHz.

4.7.4 DEVIATION FROM TEST STANDARD

No deviation

4.7.5 TEST SETUP

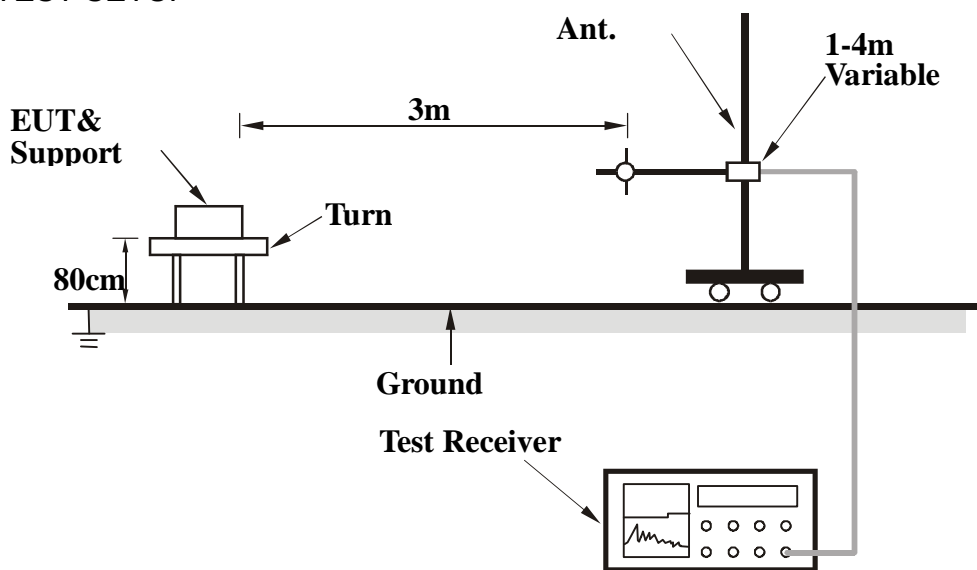

For the actual test configuration, please refer to the related item – Photographs of the Test Configuration.

4.7.6 EUT OPERATING CONDITIONS

- a. The Notebook controlled EUT to export rated output power under transmission mode and specific channel frequency.

4.7.7 TEST RESULTS

MODE	Low channel	FREQUENCY RANGE	Above 1000MHz
INPUT POWER (SYSTEM)	120Vac, 60Hz	ENVIRONMENTAL CONDITIONS	18deg°C, 71%RH, 966hPa
TESTED BY	Rex Huang		

ANTENNA POLARITY & TEST DISTANCE: HORIZONTAL AT 3 M						
No.	Freq. (MHz)	Power level (dBm)	Limit (dBm)	S.G level (dBm)	C.F. (dB)	Emission Level (dBuV/m)
1	5002.00	-45.74 PK	-13.00	-72.71	26.97	50.56
2	7503.00	-46.02 PK	-13.00	-77.74	31.72	50.18

ANTENNA POLARITY & TEST DISTANCE: VERTICAL AT 3 M						
No.	Freq. (MHz)	Emission Level (dBm)	Limit (dBm)	S.G level (dBm)	C.F. (dB)	Emission Level (dBuV/m)
1	5002.00	-35.81 PK	-13.00	-62.78	26.97	59.79
2	7503.00	-38.11 PK	-13.00	-69.83	31.72	57.19

REMARKS: 1. Power Value(dBm)=S.G Power Value (dBm) + Correction Factor(dB)

MODE	Middle channel	FREQUENCY RANGE	Above 1000MHz
INPUT POWER (SYSTEM)	120Vac, 60Hz	ENVIRONMENTAL CONDITIONS	18deg°C, 71%RH, 966hPa
TESTED BY	Rex Huang		

ANTENNA POLARITY & TEST DISTANCE: HORIZONTAL AT 3 M						
No.	Freq. (MHz)	Power level (dBm)	Limit (dBm)	S.G level (dBm)	C.F. (dB)	Emission Level (dBuV/m)
1	5175.00	-42.06 PK	-13.00	-69	26.94	53.64
2	7762.50	-45.71 PK	-13.00	-77.85	32.14	50.39

ANTENNA POLARITY & TEST DISTANCE: VERTICAL AT 3 M						
No.	Freq. (MHz)	Emission Level (dBm)	Limit (dBm)	S.G level (dBm)	C.F. (dB)	Emission Level (dBuV/m)
1	5175.00	-31.60 PK	-13.00	-58.54	26.94	63.8
2	7762.50	-35.44 PK	-13.00	-67.58	32.14	60.86

REMARKS: 1. Power Value(dBm)=S.G Power Value (dBm) + Correction Factor(dB)



MODE	High channel	FREQUENCY RANGE	Above 1000MHz
INPUT POWER (SYSTEM)	120Vac, 60Hz	ENVIRONMENTAL CONDITIONS	24deg°C, 69%RH, 991hPa
TESTED BY	Morgan Chen		

ANTENNA POLARITY & TEST DISTANCE: HORIZONTAL AT 3 M						
No.	Freq. (MHz)	Power level (dBm)	Limit (dBm)	S.G level (dBm)	C.F. (dB)	Emission Level (dBuV/m)
1	5370.00	-35.69 PK	-13.00	-62.77	27.08	60.51
2	8055.00	-44.64 PK	-13.00	-77.17	32.53	51.76

ANTENNA POLARITY & TEST DISTANCE: VERTICAL AT 3 M						
No.	Freq. (MHz)	Emission Level (dBm)	Limit (dBm)	S.G level (dBm)	C.F. (dB)	Emission Level (dBuV/m)
1	5370.00	-23.81 PK	-13.00	-50.89	27.08	72.49
2	8055.00	-35.63 PK	-13.00	-68.16	32.53	60.57

REMARKS: 1. Power Value(dBm)=S.G Power Value (dBm) + Correction Factor(dB)



5 PHOTOGRAPHS OF THE TEST CONFIGURATION

Please refer to the attached file (Test Setup Photo).



6 INFORMATION ON THE TESTING LABORATORIES

We, ADT Corp., were founded in 1988 to provide our best service in EMC, Radio, Telecom and Safety consultation. Our laboratories are accredited and approved by the following approval agencies according to ISO/IEC 17025.

USA	FCC, UL, A2LA
GERMANY	TUV Rheinland
JAPAN	VCCI
NORWAY	NEMKO
CANADA	INDUSTRY CANADA , CSA
R.O.C.	TAF, BSMI, NCC
NETHERLANDS	Telefication
SINGAPORE	GOST-ASIA (MOU)
RUSSIA	CERTIS (MOU)

Copies of accreditation certificates of our laboratories obtained from approval agencies can be downloaded from our web site:

www.adt.com.tw/index.5/phtml. If you have any comments, please feel free to contact us at the following:

Linko EMC/RF Lab:

Tel: 886-2-26052180

Fax: 886-2-26051924

Hsin Chu EMC/RF Lab:

Tel: 886-3-5935343

Fax: 886-3-5935342

Hwa Ya EMC/RF/Safety/Telecom Lab: Web Site: www.adt.com.tw

Tel: 886-3-3183232

Fax: 886-3-3185050

The address and road map of all our labs can be found in our web site also.