

TEST REPORT

CERTIFICATE OF CONFORMITY

Standard: 47 CFR FCC Part 15, Subpart E (Section 15.407)
Report No.: RFBFBE-WTW-P22090890-1
FCC ID: I88EX7710-B0
Product: AX11000 WiFi 6E 10G Ethernet Gateway
Brand: ZYXEL
Model No.: EX7710-B0
Received Date: 2022/12/1
Test Date: 2022/12/9 ~ 2023/1/20
Issued Date: 2023/2/17

Applicant: Zyxel Communications Corporation

Address: No.2 Industry East RD. IX, Hsinchu Science Park, Hsinchu 30075, Taiwan, R.O.C

Issued By: Bureau Veritas Consumer Products Services (H.K.) Ltd., Taoyuan Branch
Hsin Chu Laboratory

Lab Address: E-2, No.1, Li Hsin 1st Road, Hsinchu Science Park, Hsinchu City 300, Taiwan

Test Location: E-2, No.1, Li Hsin 1st Road, Hsinchu Science Park, Hsinchu City 300, Taiwan

FCC Registration / 723255 / TW2022

Designation Number:

Approved by: _____, **Date:** 2023/2/17
May Chen / Manager

This test report consists of 100 pages in total. It may be duplicated completely for legal use with the approval of the applicant. It should not be reproduced except in full, without the written approval of our laboratory. The test results in the report only apply to the tested sample. The test results in this report are traceable to the national or international standards.



Prepared by : Vivian Huang / Specialist

This report is governed by, and incorporates by reference, the Conditions of Testing as posted at the date of issuance of this report at <http://www.bureauveritas.com/home/about-us/our-business/cps/about-us/terms-conditions/> and is intended for your exclusive use. Any copying or replication of this report to or for any other person or entity, or use of our name or trademark, is permitted only with our prior written permission. This report sets forth our findings solely with respect to the test samples identified herein. The results set forth in this report are not indicative or representative of the quality or characteristics of the lot from which a test sample was taken or any similar or identical product unless specifically and expressly noted. Our report includes all of the tests requested by you and the results thereof based upon the information that you provided to us. Measurement uncertainty is only provided upon request for accredited tests. Statements of conformity are based on simple acceptance criteria without taking measurement uncertainty into account, unless otherwise requested in writing. You have 60 days from date of issuance of this report to notify us of any material error or omission caused by our negligence or if you require measurement uncertainty; provided, however, that such notice shall be in writing and shall specifically address the issue you wish to raise. A failure to raise such issue within the prescribed time shall constitute your unqualified acceptance of the completeness of this report, the tests conducted and the correctness of the report contents.

Table of Contents

Release Control Record	4
1 Certificate	5
2 Summary of Test Results	6
2.1 Measurement Uncertainty	6
2.2 Supplementary Information	6
3 General Information	7
3.1 General Description of EUT	7
3.2 Antenna Description of EUT	8
3.3 Channel List	11
3.4 Power Setting	12
3.5 Test Mode Applicability and Tested Channel Detail	13
3.6 Duty Cycle of Test Signal	14
3.7 Test Program Used and Operation Descriptions	16
3.8 Connection Diagram of EUT and Peripheral Devices	16
3.9 Configuration of Peripheral Devices and Cable Connections	17
4 Test Instruments	18
4.1 RF Output Power	18
4.2 Power Spectral Density	18
4.3 6 dB Bandwidth	18
4.4 Occupied Bandwidth	18
4.5 Frequency Stability	19
4.6 AC Power Conducted Emissions	19
4.7 Unwanted Emissions below 1 GHz	20
4.8 Unwanted Emissions above 1 GHz	21
5 Limits of Test Items	22
5.1 RF Output Power	22
5.2 Power Spectral Density	22
5.3 6 dB Bandwidth	22
5.4 Occupied Bandwidth	22
5.5 Frequency Stability	22
5.6 AC Power Conducted Emissions	23
5.7 Unwanted Emissions below 1 GHz	23
5.8 Unwanted Emissions above 1 GHz	24
6 Test Arrangements	25
6.1 RF Output Power	25
6.1.1 Test Setup	25
6.1.2 Test Procedure	25
6.2 Power Spectral Density	25
6.2.1 Test Setup	25
6.2.2 Test Procedure	25
6.3 6 dB Bandwidth	26
6.3.1 Test Setup	26
6.3.2 Test Procedure	26
6.4 Occupied Bandwidth	26
6.4.1 Test Setup	26
6.4.2 Test Procedure	26
6.5 Frequency Stability	27
6.5.1 Test Setup	27
6.5.2 Test Procedure	27
6.6 AC Power Conducted Emissions	28
6.6.1 Test Setup	28
6.6.2 Test Procedure	28
6.7 Unwanted Emissions below 1 GHz	29
6.7.1 Test Setup	29



6.7.2	Test Procedure.....	30
6.8	Unwanted Emissions above 1 GHz.....	31
6.8.1	Test Setup.....	31
6.8.2	Test Procedure.....	31
7	Test Results of Test Item.....	32
7.1	RF Output Power.....	32
7.2	Power Spectral Density.....	37
7.3	6 dB Bandwidth.....	41
7.4	Occupied Bandwidth.....	43
7.5	Frequency Stability.....	51
7.6	AC Power Conducted Emissions.....	52
7.7	Unwanted Emissions below 1 GHz.....	54
7.8	Unwanted Emissions above 1 GHz.....	56
8	Pictures of Test Arrangements.....	99
9	Information of the Testing Laboratories.....	100



Release Control Record

Issue No.	Description	Date Issued
RFBFBE-WTW-P22090890-1	Original release.	2023/2/17

1 Certificate

Product: AX11000 WiFi 6E 10G Ethernet Gateway

Brand: ZYXEL

Test Model: EX7710-B0

Sample Status: Engineering sample

Applicant: Zyxel Communications Corporation

Test Date: 2022/12/9 ~ 2023/1/20

Standard: 47 CFR FCC Part 15, Subpart E (Section 15.407)

Measurement ANSI C63.10-2013

procedure: KDB 789033 D02 General UNII Test Procedure New Rules v02r01

KDB 662911 D01 Multiple Transmitter Output v02r01

The above equipment has been tested by **Bureau Veritas Consumer Products Services (H.K.) Ltd., Taoyuan Branch**, and found compliance with the requirement of the above standards. The test record, data evaluation & Equipment Under Test (EUT) configurations represented herein are true and accurate accounts of the measurements of the sample's RF characteristics under the conditions specified in this report.

2 Summary of Test Results

47 CFR FCC Part 15, Subpart E (Section 15.407)			
Clause	Test Item	Result	Remark
15.407(a)(1) 15.407(a)(3)	RF Output Power	Pass	Meet the requirement of limit.
15.407(a)(1) 15.407(a)(3)	Power Spectral Density	Pass	Meet the requirement of limit.
15.407(e)	6 dB Bandwidth	Pass	Meet the requirement of limit. (U-NII-3 Band only)
---	Occupied Bandwidth	-	Reference only.
15.407(g)	Frequency Stability	Pass	Meet the requirement of limit.
15.407(b)(9)	AC Power Conducted Emissions	Pass	Minimum passing margin is -15.90 dB at 0.15000 MHz
15.407(b)(9)	Unwanted Emissions below 1 GHz	Pass	Minimum passing margin is -3.1 dB at 499.99 MHz
15.407(b) (1/10) 15.407(b) (4(i)/10)	Unwanted Emissions above 1 GHz	Pass	Minimum passing margin is -0.5 dB at 15720.00, 5147.45, 5150.00, 5646.27 MHz
15.203	Antenna Requirement	Pass	No antenna connector is used.

Note: Determining compliance based on the results of the compliance measurement, not taking into account measurement instrumentation uncertainty.

2.1 Measurement Uncertainty

Where relevant, the following measurement uncertainty levels have been estimated for tests performed on the EUT as specified in CISPR 16-4-2:

Parameter	Specification	Uncertainty (±)
AC Power Conducted Emissions	150 kHz ~ 30 MHz	1.9 dB
Unwanted Emissions below 1 GHz	9 kHz ~ 30 MHz	3.1 dB
	30 MHz ~ 1 GHz	5.1 dB
Unwanted Emissions above 1 GHz	1 GHz ~ 18 GHz	5.0 dB
	18 GHz ~ 40 GHz	5.3 dB

The other instruments specified are routine verified to remain within the calibrated levels, no measurement uncertainty is required to be calculated.

2.2 Supplementary Information

There is not any deviation from the test standards for the test method, and no modifications required for compliance.

3 General Information

3.1 General Description of EUT

Product	AX11000 WiFi 6E 10G Ethernet Gateway
Brand	ZYXEL
Test Model	EX7710-B0
CPU Model No.	BCM4912
RF Chip Model No.	2.4G Chip Model: BCM6715 5G Chip Model: BCM6715 6G Chip Model: BCM6715
FW Version	V5.18(ACAK.0)b5_20221215
Status of EUT	Engineering sample
Power Supply Rating	12Vdc from power adapter
Modulation Type	64QAM, 16QAM, QPSK, BPSK for OFDM 256QAM for OFDM in 11ac mode 1024QAM for OFDMA in 11ax mode
Modulation Technology	OFDM, OFDMA
Transfer Rate	802.11a: up to 54Mbps 802.11n: up to 600Mbps 802.11ac: up to 1733.3 Mbps 802.11ax: up to 2401.9 Mbps
Operating Frequency	5.18 GHz ~ 5.24 GHz 5.745 GHz ~ 5.825 GHz
Number of Channel	802.11a, 802.11n (HT20), 802.11ac (VHT20), 802.11ax (HE20): 9 802.11n (HT40), 802.11ac (VHT40), 802.11ax (HE40): 4 802.11ac (VHT80), 802.11ax (HE80): 2
Output Power	CDD Mode: 5.18 GHz ~ 5.24 GHz : 961.417 mW (29.83 dBm) 5.745 GHz ~ 5.825 GHz : 877.786 mW (29.43 dBm) Beamforming Mode: 5.18 GHz ~ 5.24 GHz : 742.425 mW (28.71 dBm) 5.745 GHz ~ 5.825 GHz : 877.786 mW (29.43 dBm)
EUT Category	Indoor Access Point
Accessory Device	- AC Adapter x1, Brand: APD, Model: WA-42F12FU - Ethernet Cable x1 (1m, Unshielded)

Note:

1. The EUT power needs to be supplied from a power adapter, the information is as below table:

AC Adapter 1			
Brand	Model	Specification	The housing color
APD	WA-42F12FU	AC Input: 100-240Vac, 50/60Hz, 1.2A Max. DC Output: 12Vdc, 3.5A DC Output Cable: Unshielded, 1.5m, without core bonded Manufacturer: ASIAN POWER DEVICES INC.	Black / White

2. The EUT has three radios as following table:

Radio 1	Radio 2	Radio 3
WLAN 2.4GHz	WLAN 5GHz	WLAN 6GHz

3. Simultaneously transmission condition.

Condition	Technology		
1	WLAN 2.4GHz	WLAN 5GHz	WLAN 6GHz

Note: The emission of the simultaneous operation has been evaluated and no non-compliance was found.

4. The above EUT information is declared by manufacturer and for more detailed features description, please refer to the manufacturer's specifications or user's manual.

3.2 Antenna Description of EUT

1. The antenna information is listed as below.

Antenna NO.	RF Chain NO.	Brand	Part Number	Antenna Net Gain(dBi)	Frequency range	Antenna Type	Connector Type	Cable Length
Ant1_Dual-band	2.4G Chain 2 5G Chain 2	Airgain	N03ZYAHA- PK1-G110U	3.8	2.4~2.4835GHz	Dipole	ipex(MHF)	110mm
				3.6	5.15~5.25GHz			
				4.1	5.25~5.35GHz			
				3.7	5.47~5.725GHz			
				4.2	5.725~5.85GHz			
Ant2_Dual-band	2.4G Chain 1 5G Chain 1	Airgain	N03ZYAHB- PK1-B135U	4.6	2.4~2.4835GHz	Dipole	ipex(MHF)	135mm
				5.3	5.15~5.25GHz			
				5.0	5.25~5.35GHz			
				4.9	5.47~5.725GHz			
Ant3_Dual-band	2.4G Chain 0 5G Chain 0	Airgain	N03ZYAHC- PK1-W195U	5.2	5.15~5.25GHz	Dipole	ipex(MHF)	195mm
				3.4	2.4~2.4835GHz			
				5.3	5.25~5.35GHz			
				4.8	5.47~5.725GHz			
Ant4	2.4G Chain 3	Airgain	N03ZYAHD- PK1-A90U	5.0	2.4~2.4835GHz	Dipole	ipex(MHF)	90mm
				4.2	5.725~5.85GHz			
Ant5_5GHz	5G Chain 3	Airgain	N02ZYAHE- PK1-A105U	4.5	5.15~5.25GHz	Dipole	ipex(MHF)	105mm
				4.1	5.25~5.35GHz			
				4.3	5.47~5.725GHz			
				4.6	5.725~5.85GHz			
Ant6_6GHz	6G Chain 3	Airgain	N06ZYAHF- PK1-E100U	5.9	5.925~6.425GHz	Dipole	ipex(MHF)	100m
				5.9	6.425~6.525GHz			
				5.9	6.525~6.875GHz			
				4.8	6.875~7.125GHz			
Ant7_6GHz	6G Chain 2	Airgain	N06ZYAHG- PK1-R95U	5.6	5.925~6.425GHz	Dipole	ipex(MHF)	95mm
				5.5	6.425~6.525GHz			
				5.4	6.525~6.875GHz			
				5.7	6.875~7.125GHz			
Ant8_6GHz	6G Chain 1	Airgain	N06ZYAHH- PK1-Y75U	5.7	5.925~6.425GHz	Dipole	ipex(MHF)	75mm
				5.9	6.425~6.525GHz			
				6.0	6.525~6.875GHz			
Ant9_6GHz	6G Chain 0	Airgain	N06ZYAHJ- PK1-P75U	5.9	6.875~7.125GHz	Dipole	ipex(MHF)	75mm
				4.7	5.925~6.425GHz			
				3.7	6.425~6.525GHz			
				4.0	6.525~6.875GHz			
				4.0	6.875~7.125GHz			

* Detail antenna specification please refer to antenna datasheet and/or antenna measurement report.

* Antenna port location

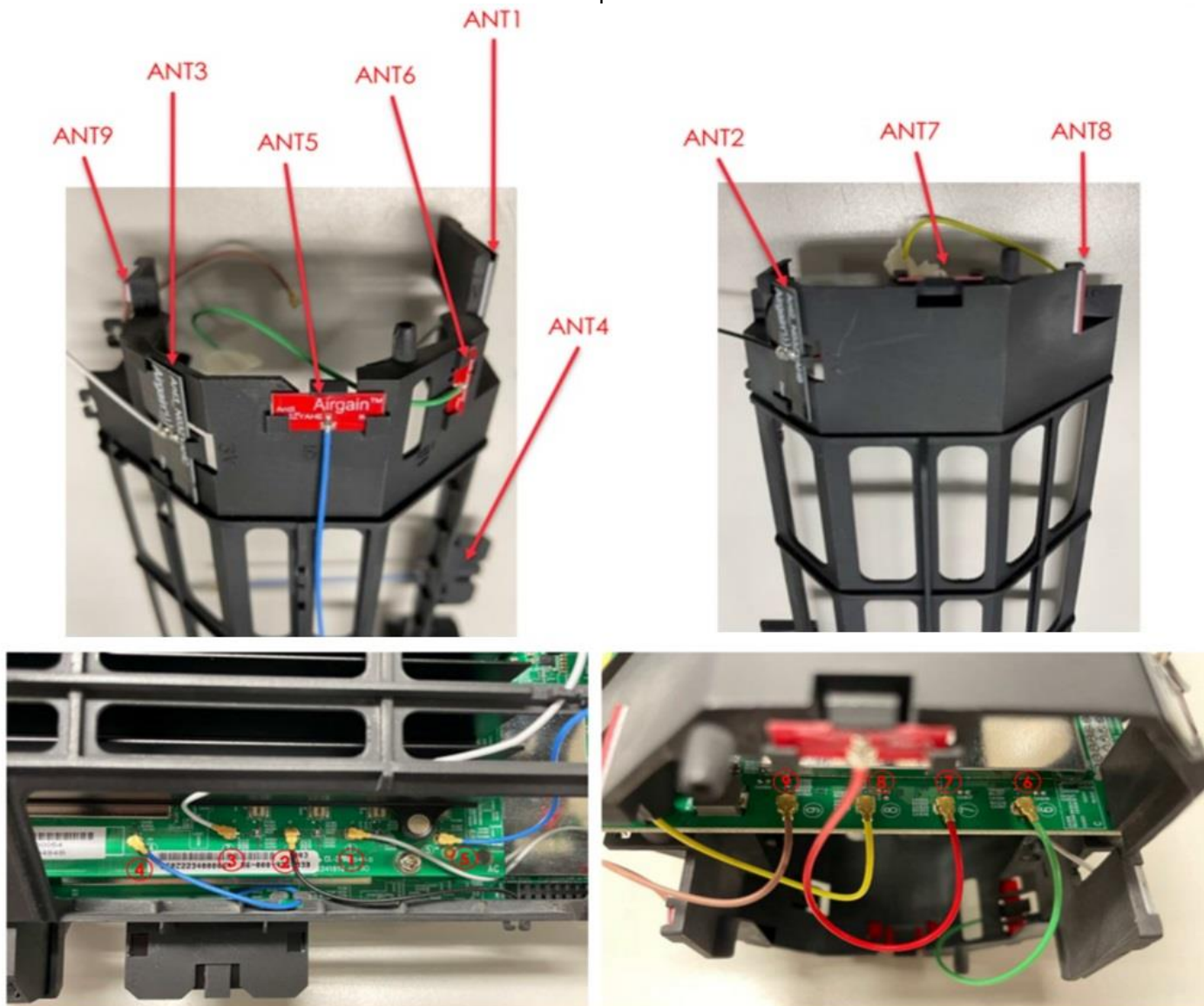

2. The directional antenna gain, please refer to the following table:

Frequency Range (GHz)	Directional Antenna Gain (dBi)	Antenna Type	Antenna Connector
5.15~5.25	5.52	Dipole	ipex(MHF)
5.25~5.35	5.57		
5.47~5.725	5.43		
5.725~5.85	5.53		

Note: Directional gain is the measured value according to KDB 662911 D03 Method of MIMO Antenna Gain Measurement. More detailed information, please refer to antenna specification.

3. The EUT incorporates a MIMO function:

5 GHz Band		
Modulation Mode	TX & RX Configuration	
802.11a	4TX	4RX
802.11n (HT20)	4TX	4RX
802.11n (HT40)	4TX	4RX
802.11ac (VHT20)	4TX	4RX
802.11ac (VHT40)	4TX	4RX
802.11ac (VHT80)	4TX	4RX
802.11ax (HE20)	4TX	4RX
802.11ax (HE40)	4TX	4RX
802.11ax (HE80)	4TX	4RX

Note:

1. All of modulation mode support beamforming function except 802.11a modulation mode.
2. The EUT support Beamforming and CDD mode, therefore both mode were investigated and the worst case scenario was identified. The worst case data were presented in test report.
3. The modulation and bandwidth are similar for 802.11n mode for 20 MHz (40 MHz), 802.11ac mode for 20 MHz (40 MHz, 80 MHz) and 802.11ax mode for 20 MHz (40MHz, 80 MHz), therefore the manufacturer will control the power for 802.11n/ac mode is the same as the 802.11ax or more lower than it and investigated worst case to representative mode in test report.

3.3 Channel List

FOR 5180 ~ 5240MHz

4 channels are provided for 802.11a, 802.11n (HT20), 802.11ac (VHT20), 802.11ax (HE20):

Channel	Frequency	Channel	Frequency
36	5180 MHz	44	5220 MHz
40	5200 MHz	48	5240 MHz

2 channels are provided for 802.11n (HT40), 802.11ac (VHT40), 802.11ax (HE40):

Channel	Frequency	Channel	Frequency
38	5190 MHz	46	5230 MHz

1 channel is provided for 802.11ac (VHT80), 802.11ax (HE80):

Channel	Frequency
42	5210 MHz

FOR 5745 ~ 5825MHz:

5 channels are provided for 802.11a, 802.11n (HT20), 802.11ac (VHT20), 802.11ax (HE20):

Channel	Frequency	Channel	Frequency
149	5745 MHz	161	5805 MHz
153	5765 MHz	165	5825 MHz
157	5785 MHz		

2 channels are provided for 802.11n (HT40), 802.11ac (VHT40), 802.11ax (HE40):

Channel	Frequency	Channel	Frequency
151	5755 MHz	159	5795 MHz

1 channel is provided for 802.11ac (VHT80), 802.11ax (HE80):

Channel	Frequency
155	5775 MHz

3.4 Power Setting

Power Setting						
Channel	802.11a CDD	802.11ac (VHT20) CDD	Channel	802.11ac (VHT40) CDD	Channel	802.11ac (VHT80) CDD
36	95	88	38	79	42	77
40	98	92	46	88	155	84
48	93	92	151	93		
149	93	93	159	93		
157	93	93				
165	93	93				

Power Setting					
Channel	802.11ax (HE20) CDD	Channel	802.11ax (HE40) CDD	Channel	802.11ax (HE80) CDD
36	88	38	79	42	77
40	92	46	88	155	84
48	92	151	93		
149	93	159	93		
157	93				
165	93				

Power Setting					
Channel	802.11ac (VHT20) Beamforming	Channel	802.11ac (VHT40) Beamforming	Channel	802.11ac (VHT80) Beamforming
36	88	38	79	42	77
40	92	46	88	155	84
48	92	151	93		
149	93	159	93		
157	93				
165	93				

Power Setting					
Channel	802.11ax (HE20) Beamforming	Channel	802.11ax (HE40) Beamforming	Channel	802.11ax (HE80) Beamforming
36	88	38	79	42	77
40	92	46	88	155	84
48	92	151	93		
149	93	159	93		
157	93				
165	93				

3.5 Test Mode Applicability and Tested Channel Detail

Pre-Scan:	1. Pre-Scan has been conducted to determine the worst-case mode from all possible combinations between available modulations, data rates and antenna ports (if EUT with antenna diversity architecture).
-----------	--

Following channel(s) was (were) selected for the final test as listed below:

Test Item	Mode	Signal Mode	Tested Channel	Modulation	Data Rate Parameter
Occupied Bandwidth / Power Spectral Density	802.11a	CDD	36, 40, 48, 149, 157, 165	BPSK	6Mb/s
	802.11ax (HE20)	CDD	36, 40, 48, 149, 157, 165	BPSK	MCS0
	802.11ax (HE40)	CDD	38, 46, 151, 159	BPSK	MCS0
	802.11ax (HE80)	CDD	42, 155	BPSK	MCS0
6 dB Bandwidth	802.11a	CDD	149, 157, 165	BPSK	6Mb/s
	802.11ax (HE20)	CDD	149, 157, 165	BPSK	MCS0
	802.11ax (HE40)	CDD	151, 159	BPSK	MCS0
	802.11ax (HE80)	CDD	155	BPSK	MCS0
RF Output Power	802.11a	CDD	36, 40, 48, 149, 157, 165	BPSK	6Mb/s
	802.11ac (VHT20)	CDD & Beamforming	36, 40, 48, 149, 157, 165	BPSK	MCS0
	802.11ac (VHT40)	CDD & Beamforming	38, 46, 151, 159	BPSK	MCS0
	802.11ac (VHT80)	CDD & Beamforming	42, 155	BPSK	MCS0
	802.11ax (HE20)	CDD & Beamforming	36, 40, 48, 149, 157, 165	BPSK	MCS0
	802.11ax (HE40)	CDD & Beamforming	38, 46, 151, 159	BPSK	MCS0
	802.11ax (HE80)	CDD & Beamforming	42, 155	BPSK	MCS0
Frequency Stability	802.11a	-	36	un-modulation	-
AC Power Conducted Emissions	802.11a	CDD	40	BPSK	6Mb/s
Unwanted Emissions below 1 GHz	802.11a	CDD	40	BPSK	6Mb/s
Unwanted Emissions above 1 GHz	802.11a	CDD	36, 40, 48, 149, 157, 165	BPSK	6Mb/s
	802.11ax (HE20)	CDD	36, 40, 48, 149, 157, 165	BPSK	MCS0
	802.11ax (HE40)	CDD	38, 46, 151, 159	BPSK	MCS0
	802.11ax (HE80)	CDD	42, 155	BPSK	MCS0

Note: Partial RU (resource unit) and channel puncturing/bandwidth reduction configurations are not supported.

3.6 Duty Cycle of Test Signal

802.11a: Duty cycle = 3.009 ms / 3.035 ms x 100% = 99.1%

802.11ax (HE20): Duty cycle = 3.312 ms / 3.339 ms x 100% = 99.2%

802.11ax (HE40): Duty cycle = 3.312 ms / 3.338 ms x 100% = 99.2%

802.11ax (HE80): Duty cycle = 3.167 ms / 3.193 ms x 100% = 99.2%

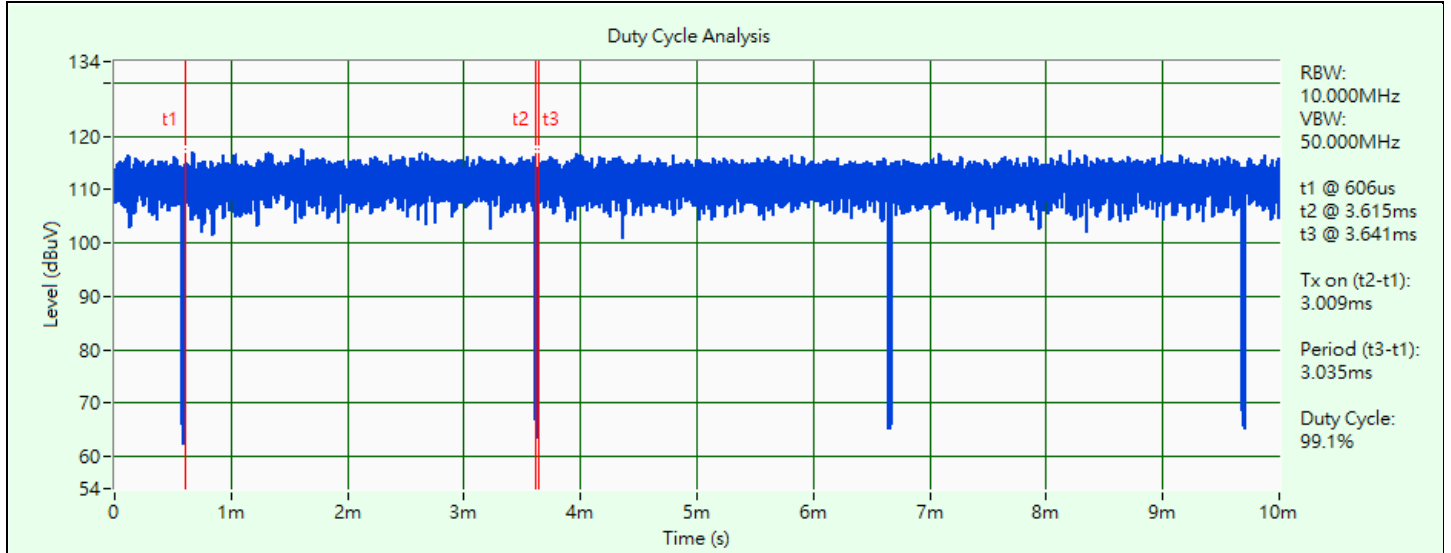

802.11a

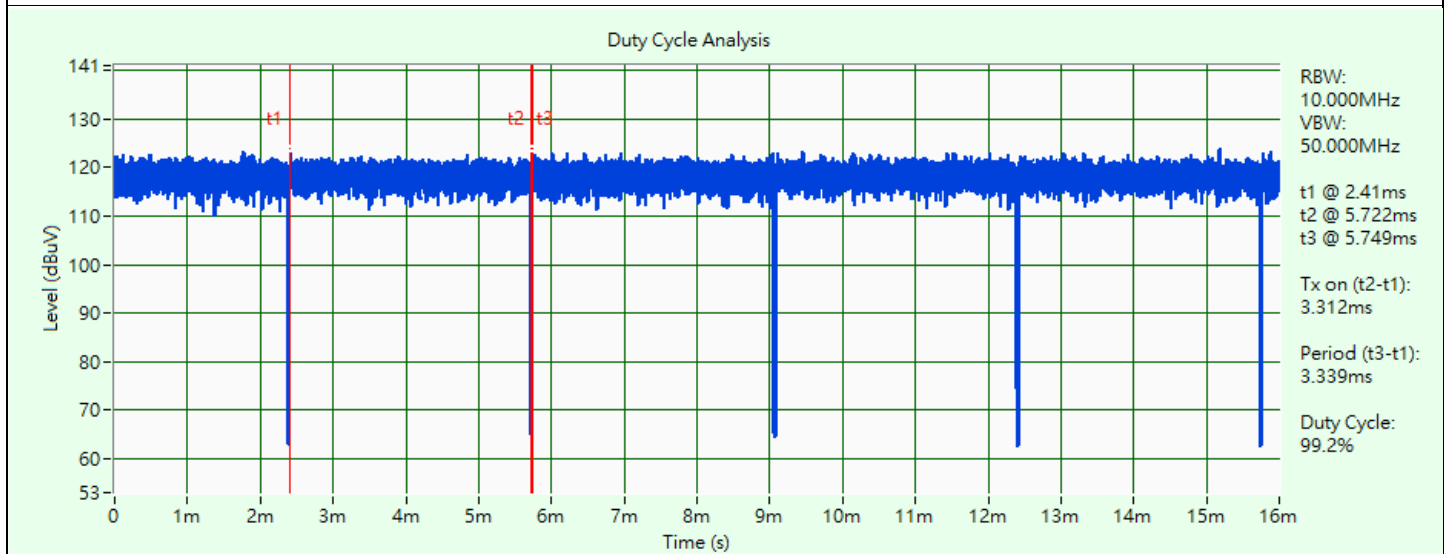

802.11ax (HE20)

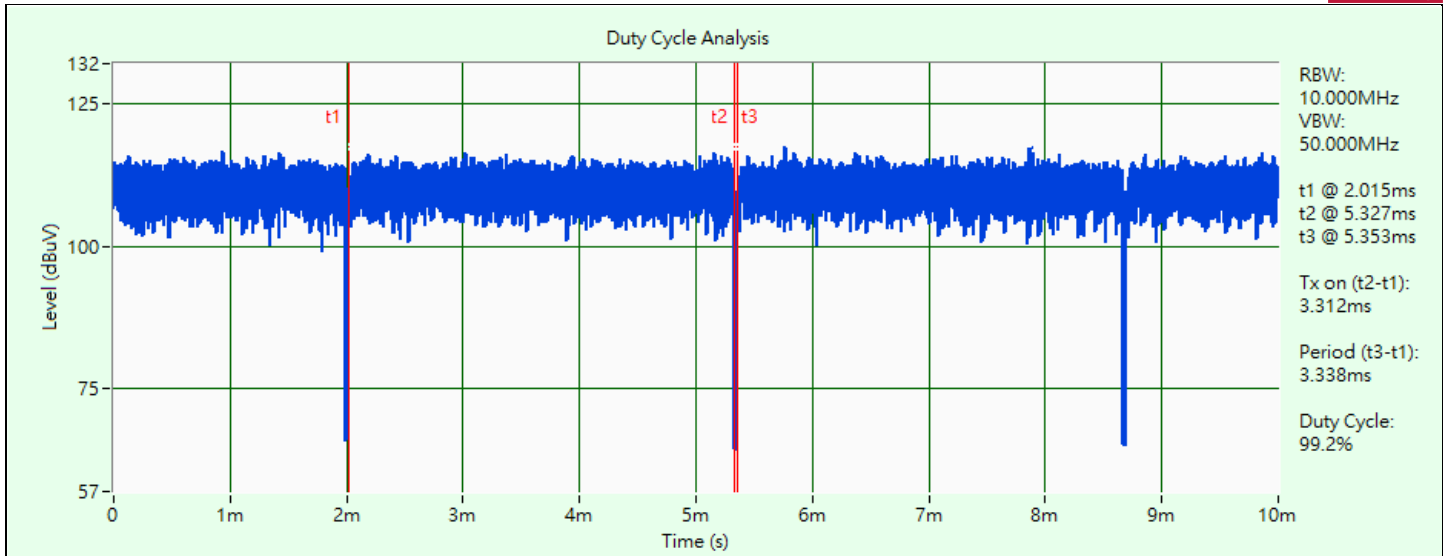

802.11ax (HE40)

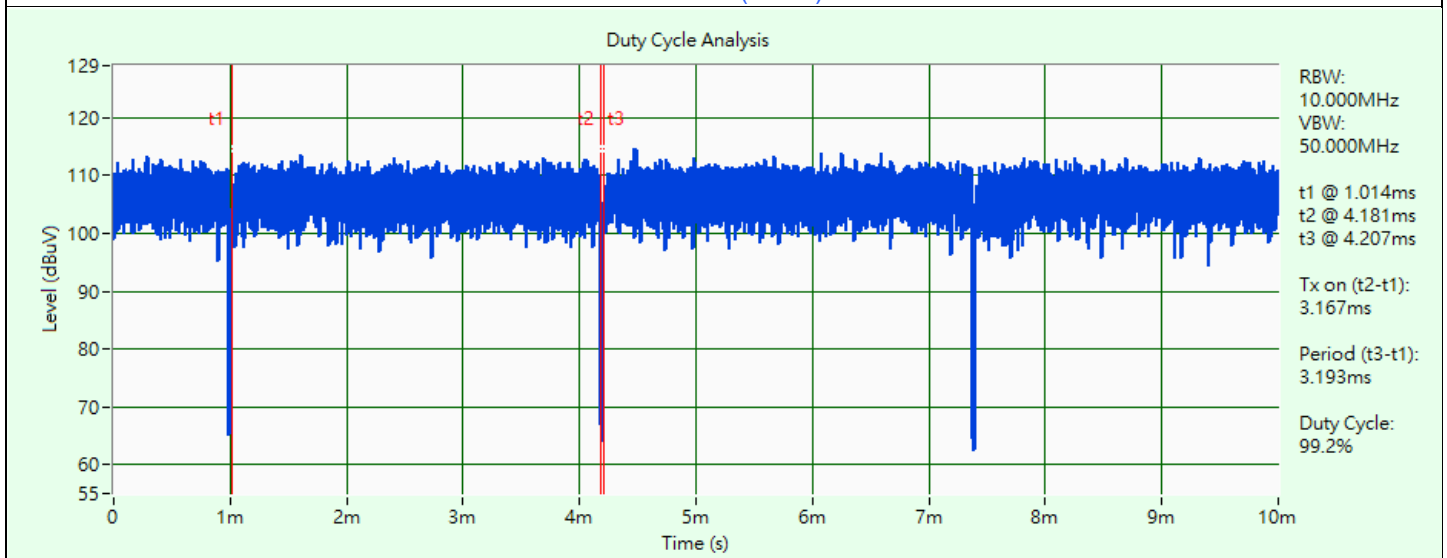

802.11ax (HE80)

3.7 Test Program Used and Operation Descriptions

Controlling software (accessMTool_REL_3_2_1_3) has been activated to set the EUT under transmission condition continuously at specific channel frequency.

3.8 Connection Diagram of EUT and Peripheral Devices

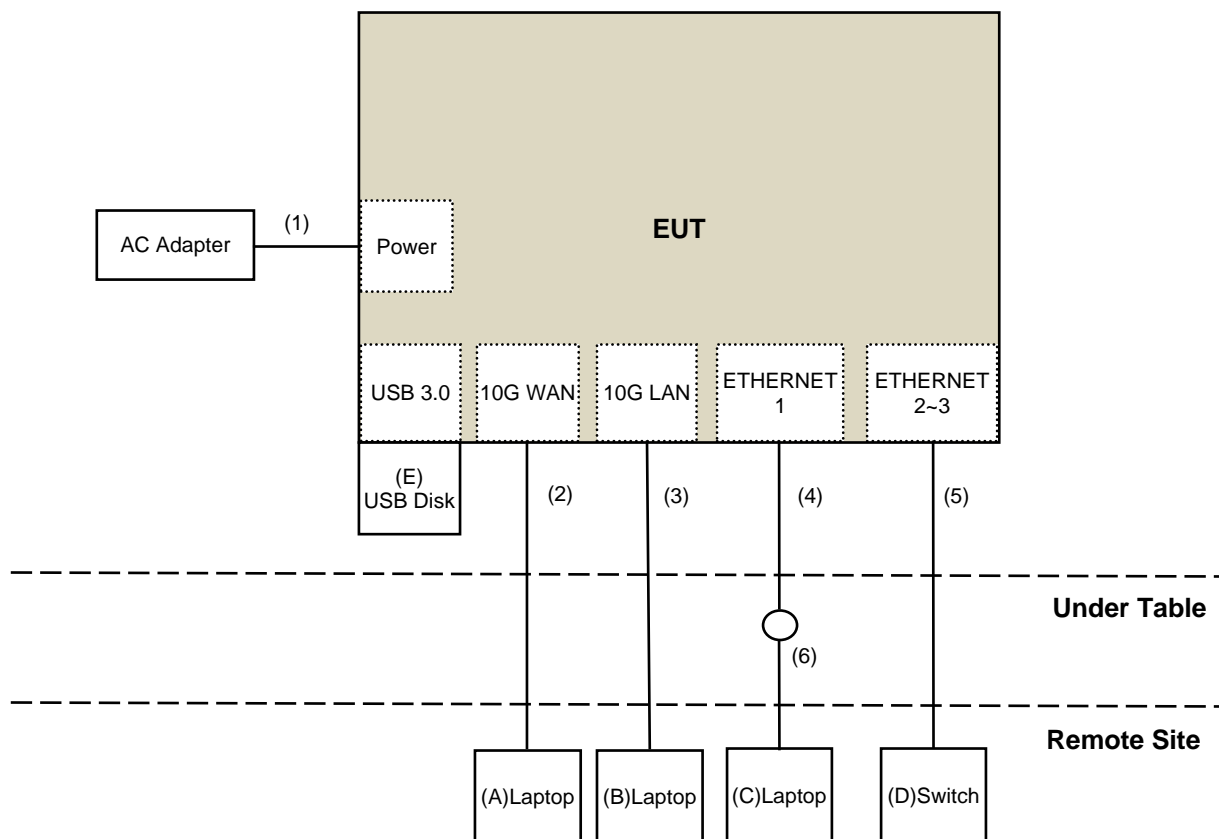

3.9 Configuration of Peripheral Devices and Cable Connections

ID	Product	Brand	Model No.	Serial No.	FCC ID	Remarks
A	Laptop	Lenovo	20U5S01X00 L14	PF-28LKK7	N/A	Provided by Lab
B	Laptop	Lenovo	20U5S01X00 L14	PF-1ANPYA	N/A	Provided by Lab
C	Laptop	HP	TPN-Q186	5CD8212YYK	DoC	Provided by Lab
D	Switch	D-Link	DGS-1005D	DR8WC92000523	N/A	Provided by Lab
E	USB Disk	SanDisk	BM181225896Z	N/A	N/A	Provided by Lab

ID	Cable Descriptions	Qty.	Length (m)	Shielding (Yes/No)	Cores (Qty.)	Remarks
1	DC Cable	1	1.5	No	0	Supplied by applicant
2	RJ-45 Cable	1	10	No	0	Provided by Lab
3	RJ-45 Cable	1	10	No	0	Provided by Lab
4	Ethernet Cable	1	1	No	0	Supplied by applicant
5	RJ-45 Cable	3	10	No	0	Provided by Lab
6	RJ-45 Cable	1	10	No	0	Provided by Lab

4 Test Instruments

The calibration interval of the all test instruments are 12 months and the calibrations are traceable to NML/ROC and NIST/USA.

4.1 RF Output Power

Description Manufacturer	Model No.	Serial No.	Calibrated Date	Calibrated Until
Power Meter Anritsu	ML2495A	1529002	2022/6/22	2023/6/21
Pulse Power Sensor Anritsu	MA2411B	1726434	2022/6/22	2023/6/21
Attenuator WOKEN	MDCS18N-10	MDCS18N-10-01	2022/4/5	2023/4/4
Software	ADT_RF Test Software V6.6.5.4	N/A	N/A	N/A

Notes:

1. The test was performed in Oven room 2.
2. Tested Date: 2023/1/20

4.2 Power Spectral Density

Description Manufacturer	Model No.	Serial No.	Calibrated Date	Calibrated Until
Attenuator WOKEN	MDCS18N-10	MDCS18N-10-01	2022/4/5	2023/4/4
Software	ADT_RF Test Software V6.6.5.4	N/A	N/A	N/A
Spectrum Analyzer Keysight	N9020B	MY60112409	2022/3/11	2023/3/10

Notes:

1. The test was performed in Oven room 2.
2. Tested Date: 2023/1/20

4.3 6 dB Bandwidth

Refer to section 4.2 to get information of the instruments.

4.4 Occupied Bandwidth

Refer to section 4.2 to get information of the instruments.

4.5 Frequency Stability

Description Manufacturer	Model No.	Serial No.	Calibrated Date	Calibrated Until
AC Power Source GOOD WILL	6905S	1991551	N/A	N/A
Attenuator WOKEN	MDCS18N-10	MDCS18N-10-01	2022/4/5	2023/4/4
Software	ADT_RF Test Software V6.6.5.4	N/A	N/A	N/A
Spectrum Analyzer Keysight	N9020B	MY60112409	2022/3/11	2023/3/10
Temperature & Humidity Chamber Giant Force	GTH-150-40-SP-AR	MAA0812-008	2022/12/26	2023/12/25
True RMS Clamp Meter Fluke	325	31130711WS	2022/6/9	2023/6/8

Notes:

1. The test was performed in Oven room 2.
2. Tested Date: 2023/1/20

4.6 AC Power Conducted Emissions

Description Manufacturer	Model No.	Serial No.	Calibrated Date	Calibrated Until
50 ohm terminal resistance	N/A	EMC-01	2022/9/27	2023/9/26
Fixed attenuator STI	STI02-2200-10	005	2022/8/24	2023/8/23
LISN R&S	ESH3-Z5	848773/004	2022/10/18	2023/10/17
RF Coaxial Cable JYEBO	5D-FB	COCCAB-001	2022/8/24	2023/8/23
Software BVADT	BVADT_Cond_V7.3.7.4	N/A	N/A	N/A
TEST RECEIVER R&S	ESCS 30	847124/029	2022/10/14	2023/10/13

Notes:

1. The test was performed in Conduction 1
2. Tested Date: 2023/1/3

4.7 Unwanted Emissions below 1 GHz

Description Manufacturer	Model No.	Serial No.	Calibrated Date	Calibrated Until
Bilog Antenna Schwarzbeck	VULB 9168	9168-0942	2022/10/20	2023/10/19
Boresight Antenna Tower & Turn Table Max-Full	MF-7802BS	MF780208530	N/A	N/A
Fixed attenuator Mini-Circuits	UNAT-5+	PAD-ATT5-01	2022/12/28	2023/12/27
LOOP ANTENNA Electro-Metrics	EM-6879	264	2022/3/18	2023/3/17
Pre_Amplifier EMCI	EMC001340	980142	2022/6/2	2023/6/1
Pre_Amplifier(20M-3G) EMCI	EMC330N	980852	2022/3/28	2023/3/27
RF Coaxial Cable COMMATE/PEWC	8D	966-6-1	2022/4/25	2023/4/24
		966-6-2	2022/4/25	2023/4/24
		966-6-3	2022/4/25	2023/4/24
RF Coaxial Cable JYEBO	5D-FB	LOOPCAB-001	2022/1/6	2023/1/5
		LOOPCAB-002	2022/12/19	2023/12/18
Software	ADT_Radiated_V8.7.08	N/A	N/A	N/A
Spectrum Analyzer Keysight	N9020B	MY60112410	2022/3/13	2023/3/12
Test Receiver KEYSIGHT	N9038A	MY59050100	2022/6/20	2023/6/19

Notes:

1. The test was performed in 966 Chamber No. 6.
2. Tested Date: 2022/12/30

4.8 Unwanted Emissions above 1 GHz

Description Manufacturer	Model No.	Serial No.	Calibrated Date	Calibrated Until
Boresight Antenna Tower & Turn Table Max-Full	MF-7802BS	MF780208530	N/A	N/A
Horn Antenna Schwarzbeck	BBHA 9120D	9120D-2035	2022/11/13	2023/11/12
	BBHA 9170	BBHA9170519	2022/11/13	2023/11/12
Pre_Amplifier EMCI	EMC12630SE	980385	2022/8/15	2023/8/14
	EMC184045SE	980387	2022/1/10 2022/12/28	2023/1/9 2023/12/27
RF Cable EMCI	EMC104-SM-SM-1300	210205	2022/5/10	2023/5/9
RF Cable-Frequency range: 1- 40GHz EMCI	EMC102-KM-KM-1200	160924	2022/1/10	2023/1/9
			2022/12/28	2023/12/27
RF Coaxial Cable EMCI	EMC-KM-KM-4000	200214	2022/3/8	2023/3/7
	EMC101G-KM-KM-10000	210708	2022/11/4	2023/11/3
Software	ADT_Radiated_V8.7.08	N/A	N/A	N/A
Spectrum Analyzer Keysight	N9020B	MY60112410	2022/3/13	2023/3/12
Test Receiver KEYSIGHT	N9038A	MY59050100	2022/6/20	2023/6/19

Notes:

1. The test was performed in 966 Chamber No. 6.
2. Tested Date: 2022/12/9 ~ 2023/1/18

5 Limits of Test Items

5.1 RF Output Power

Operation Band	EUT Category	Limit
U-NII-1	Outdoor Access Point	1 Watt (30 dBm) (Max. e.i.r.p \leq 125mW(21 dBm) at any elevation angle above 30 degrees as measured from the horizon)
	Fixed point-to-point Access Point	1 Watt (30 dBm)
	Indoor Access Point	1 Watt (30 dBm)
	Mobile and Portable client device	250mW (24 dBm)

Operation Band	Limit
U-NII-3	1 Watt (30 dBm)

Per KDB 662911 D01 Multiple Transmitter Output Method of conducted output power measurement on IEEE 802.11 devices,

Array Gain = 0 dB (i.e., no array gain) for $N_{ANT} \leq 4$;

Array Gain = 0 dB (i.e., no array gain) for channel widths ≥ 40 MHz for any N_{ANT} ;

Array Gain = $5 \log(N_{ANT}/N_{SS})$ dB or 3 dB, whichever is less, for 20-MHz channel widths with $N_{ANT} \geq 5$.

For power measurements on all other devices: Array Gain = $10 \log(N_{ANT}/N_{SS})$ dB.

5.2 Power Spectral Density

Operation Band	EUT Category	Limit
U-NII-1	Outdoor Access Point	17 dBm/MHz
	Fixed point-to-point Access Point	
	Indoor Access Point	
	Mobile and Portable client device	11 dBm/MHz

Operation Band	Limit
U-NII-3	30 dBm/500 kHz

5.3 6 dB Bandwidth

Within the 5.725-5.850 GHz band, the minimum 6 dB bandwidth of U-NII devices shall be at least 500 kHz.

5.4 Occupied Bandwidth

The results are for reference only.

5.5 Frequency Stability

The frequency of the carrier signal shall be maintained within band of operation.

5.6 AC Power Conducted Emissions

Frequency (MHz)	Conducted Limit (dBuV)	
	Quasi-peak	Average
0.15 - 0.5	66 - 56	56 - 46
0.50 - 5.0	56	46
5.0 - 30.0	60	50

Notes:

1. The lower limit shall apply at the transition frequencies.
2. The limit decreases in line with the logarithm of the frequency in the range of 0.15 to 0.50 MHz.

5.7 Unwanted Emissions below 1 GHz

Radiated emissions which fall in the restricted bands must comply with the radiated emission limits specified as below table.

Frequencies (MHz)	Field Strength (microvolts/meter)	Measurement Distance (meters)
0.009 ~ 0.490	2400/F(kHz)	300
0.490 ~ 1.705	24000/F(kHz)	30
1.705 ~ 30.0	30	30
30 ~ 88	100	3
88 ~ 216	150	3
216 ~ 960	200	3
Above 960	500	3

Notes:

1. The lower limit shall apply at the transition frequencies.
2. Emission level (dBuV/m) = 20 log Emission level (uV/m).

5.8 Unwanted Emissions above 1 GHz

Radiated emissions which fall in the restricted bands must comply with the radiated emission limits specified as below table.

Frequencies (MHz)	Field Strength (microvolts/meter)	Measurement Distance (meters)
Above 960	500	3

Notes:

1. The lower limit shall apply at the transition frequencies.
2. Emission level (dBuV/m) = 20 log Emission level (uV/m).
3. For frequencies above 1000 MHz, the field strength limits are based on average detector, however, the peak field strength of any emission shall not exceed the maximum permitted average limits, specified above by more than 20 dB under any condition of modulation.

Limits of unwanted emission out of the restricted bands

Applicable To	Limit	
789033 D02 General UNII Test Procedure New Rules v02r01	Field Strength at 3 m	
	PK: 74 (dBμV/m)	AV: 54 (dBμV/m)

For transmitters operating in the 5.15-5.25 GHz band:

Applicable To	EIRP Limit	Equivalent Field Strength at 3 m
15.407(b)(1)	PK: -27 (dBm/MHz)	PK: 68.2 (dBμV/m)

For transmitters operating in the 5.725-5.850 GHz band:

Applicable To	EIRP Limit	Equivalent Field Strength at 3 m
15.407(b)(4)(i)	PK: -27 (dBm/MHz) ^{*1} PK: 10 (dBm/MHz) ^{*2} PK: 15.6 (dBm/MHz) ^{*3} PK: 27 (dBm/MHz) ^{*4}	PK: 68.2 (dBμV/m) ^{*1} PK: 105.2 (dBμV/m) ^{*2} PK: 110.8 (dBμV/m) ^{*3} PK: 122.2 (dBμV/m) ^{*4}

^{*1} beyond 75 MHz or more above of the band edge.

^{*2} below the band edge increasing linearly to 10 dBm/MHz at 25 MHz above.

^{*3} below the band edge increasing linearly to a level of 15.6 dBm/MHz at 5 MHz above.

^{*4} from 5 MHz above or below the band edge increasing linearly to a level of 27 dBm/MHz at the band edge.

Note: The following formula is used to convert the equipment isotropic radiated power (eirp) to field strength:

$$E = \frac{1000000\sqrt{30P}}{3} \mu\text{V/m, where P is the eirp (Watts).}$$

6 Test Arrangements

6.1 RF Output Power

6.1.1 Test Setup

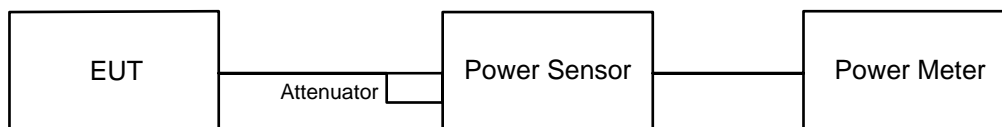

6.1.2 Test Procedure

Method PM is used to perform output power measurement, trigger and gating function of wide band power meter is enabled to measure max output power of TX on burst and set the detector to average. Duty factor is not added to measured value.

6.2 Power Spectral Density

6.2.1 Test Setup

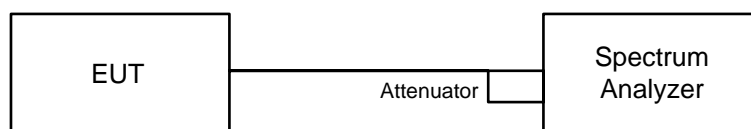

6.2.2 Test Procedure

For specified measurement bandwidth 1 MHz:

Method SA-1

- Set span to encompass the entire emission bandwidth (EBW) of the signal.
- Set RBW = 1 MHz, Set VBW \geq 3 MHz, Detector = RMS
- Sweep points \geq $[2 \times \text{span} / \text{RBW}]$. (This gives bin-to-bin spacing \leq RBW / 2, so that narrowband signals are not lost between frequency bins.)
- Sweep time = auto, trigger set to "free run".
- Trace average at least 100 traces in power averaging mode.
- Record the max value

For specified measurement bandwidth 500 kHz:

Method SA-1

- Set span to encompass the entire emission bandwidth (EBW) of the signal.
- Set RBW = 300 kHz, Set VBW \geq 1 MHz, Detector = RMS
- Scale the observed power level to an equivalent value in 500 kHz by adjusting (increasing) the measured power by a bandwidth correction factor (BWCF) where $\text{BWCF} = 10\log(500 \text{ kHz}/300 \text{ kHz})$
- Sweep points \geq $[2 \times \text{span} / \text{RBW}]$. (This gives bin-to-bin spacing \leq RBW / 2, so that narrowband signals are not lost between frequency bins.)
- Sweep time = auto, trigger set to "free run".
- Trace average at least 100 traces in power averaging mode.
- Record the max value

6.3 6 dB Bandwidth

6.3.1 Test Setup

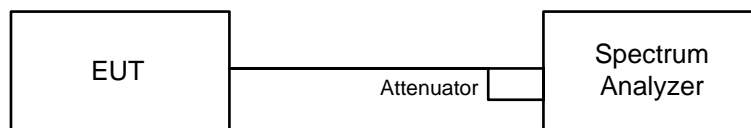

6.3.2 Test Procedure

- Set resolution bandwidth (RBW) = 100 kHz.
- Set the video bandwidth (VBW) $\geq 3 \times$ RBW, Detector = Peak.
- Trace mode = max hold.
- Sweep = auto couple.
- Measure the maximum width of the emission that is constrained by the frequencies associated with the two amplitude points (upper and lower) that are attenuated by 6 dB relative to the maximum level measured in the fundamental emission.

6.4 Occupied Bandwidth

6.4.1 Test Setup

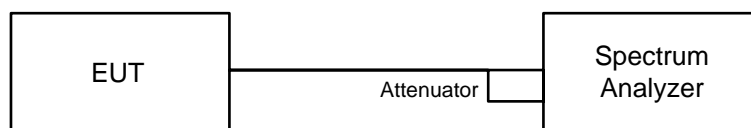

6.4.2 Test Procedure

The transmitter output was connected to the spectrum analyzer through an attenuator. The bandwidth of the fundamental frequency was measured by spectrum analyzer with resolution bandwidth in the range of 1% to 5% of the anticipated emission bandwidth, and a video bandwidth at least 3x the resolution bandwidth and set the detector to Sampling. The width of a frequency band such that, below the lower and above the upper frequency limits, the mean powers emitted are each equal to a specified percentage 0.5% of the total mean power of a given emission.

6.5 Frequency Stability

6.5.1 Test Setup

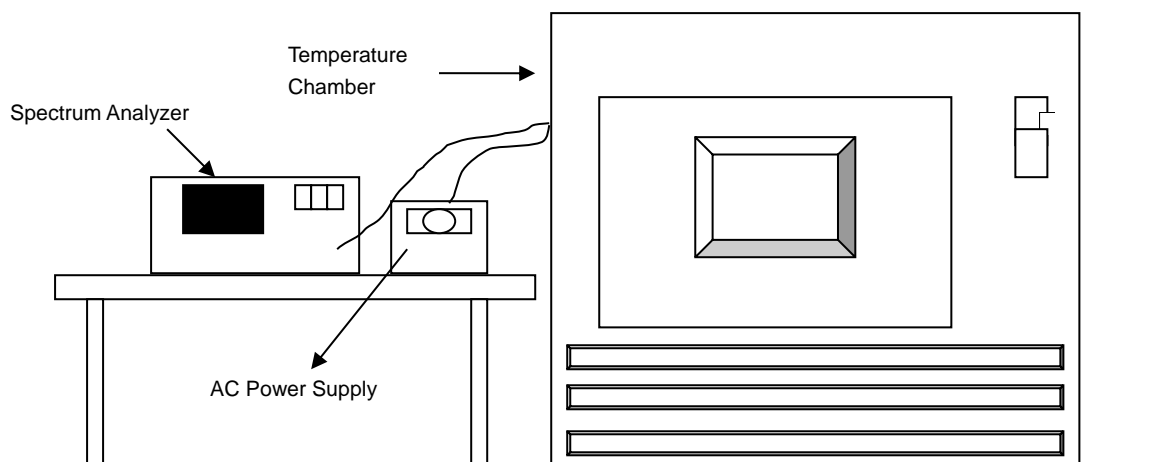

6.5.2 Test Procedure

- The EUT was placed inside the environmental test chamber and powered by nominal AC voltage.
- Turn the EUT on and couple its output to a spectrum analyzer.
- Turn the EUT off and set the chamber to the highest temperature specified.
- Allow sufficient time (approximately 30 min) for the temperature of the chamber to stabilize, turn the EUT on and measure the operating frequency after 2, 5, and 10 Minutes.
- Repeat step (d) with the temperature chamber set to the next desired temperature until measurements down to the lowest specified temperature have been completed.
- The test chamber was allowed to stabilize at +20 degree C for a minimum of 30 Minutes. The supply voltage was then adjusted on the EUT from 85% to 115% and the frequency record.

6.6 AC Power Conducted Emissions

6.6.1 Test Setup

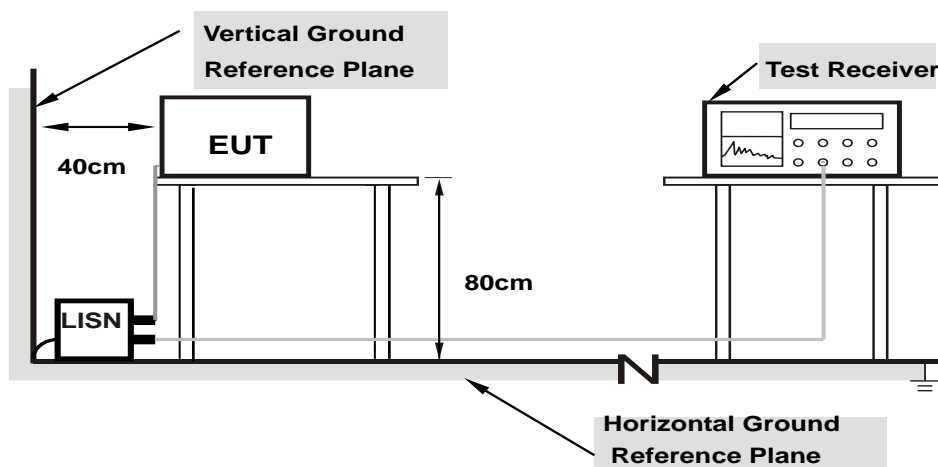

Note: 1.Support units were connected to second LISN.

For the actual test configuration, please refer to the attached file (Test Setup Photo).

6.6.2 Test Procedure

- The EUT was placed on a 0.8 meter to the top of table and placed 0.4 meters from the conducting wall of the shielded room with EUT being connected to the power mains through a line impedance stabilization network (LISN). Other support units were connected to the power mains through another LISN. The two LISNs provide 50 ohm/ 50 uH of coupling impedance for the measuring instrument.
- Both lines of the power mains connected to the EUT were checked for maximum conducted interference.
- The frequency range from 150 kHz to 30 MHz was searched. Emission levels under (Limit – 20 dB) was not recorded.

Note: The resolution bandwidth and video bandwidth of test receiver is 9 kHz for quasi-peak detection (QP) and average detection (AV) at frequency 0.15 MHz-30 MHz.

6.7 Unwanted Emissions below 1 GHz

6.7.1 Test Setup

For Radiated emission below 30 MHz

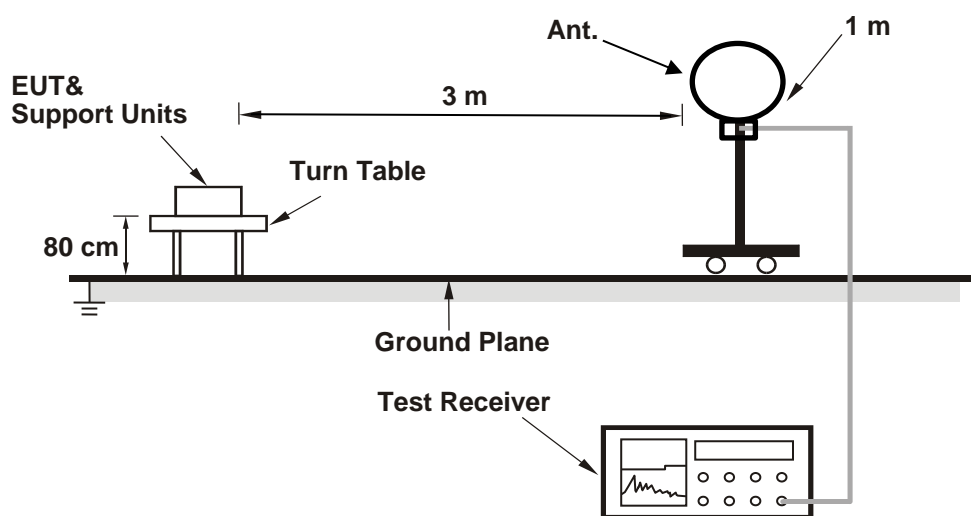

For Radiated emission above 30 MHz

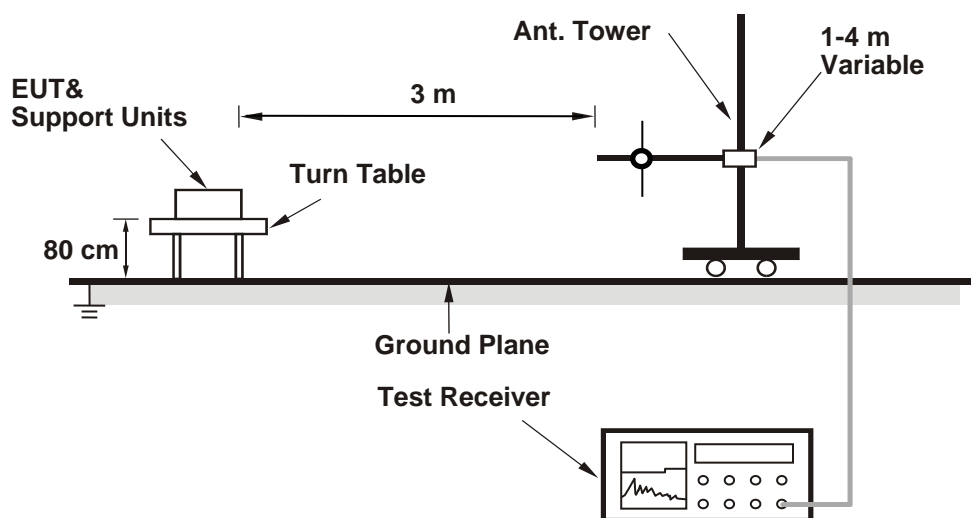

For the actual test configuration, please refer to the attached file (Test Setup Photo).

6.7.2 Test Procedure

For Radiated emission below 30 MHz

- a. The EUT was placed on the top of a rotating table 0.8 meters above the ground at 3 meter chamber room for test. The table was rotated 360 degrees to determine the position of the highest radiation.
- b. The EUT was set 3 meters away from the interference-receiving antenna, which was mounted on the top of a variable-height antenna tower.
- c. Parallel, perpendicular, and ground-parallel orientations of the antenna are set to make the measurement.
- d. For each suspected emission, the EUT was arranged to its worst case and the rotatable table was turned from 0 degrees to 360 degrees to find the maximum reading.
- e. The test-receiver system was set to Quasi-Peak Detect Function and Specified Bandwidth with Maximum Hold Mode, except for the frequency band (9 kHz to 90 kHz and 110 kHz to 490 kHz) set to average detect function and peak detect function.

Notes:

1. The resolution bandwidth and video bandwidth of test receiver/spectrum analyzer is 200 Hz at frequency below 150 kHz.
2. The resolution bandwidth and video bandwidth of test receiver/spectrum analyzer is 9 kHz or 10 kHz at frequency (150 kHz to 30 MHz).
3. All modes of operation were investigated and the worst-case emissions are reported.

For Radiated emission above 30 MHz

- a. The EUT was placed on the top of a rotating table 0.8 meters above the ground at 3 meter chamber room for test. The table was rotated 360 degrees to determine the position of the highest radiation.
- b. The EUT was set 3 meters away from the interference-receiving antenna, which was mounted on the top of a variable-height antenna tower.
- c. The height of antenna is varied from one meter to four meters above the ground to determine the maximum value of the field strength. Both horizontal and vertical polarizations of the antenna are set to make the measurement.
- d. For each suspected emission, the EUT was arranged to its worst case and then the antenna was tuned to heights from 1 meter to 4 meters and the rotatable table was turned from 0 degrees to 360 degrees to find the maximum reading.
- e. The test-receiver system was set to quasi-peak detect function and specified bandwidth with maximum hold mode when the test frequency is below 1 GHz.

Notes:

1. The resolution bandwidth and video bandwidth of test receiver/spectrum analyzer is 120 kHz for Quasi-peak detection (QP) at frequency below 1 GHz.
2. All modes of operation were investigated and the worst-case emissions are reported.

6.8 Unwanted Emissions above 1 GHz

6.8.1 Test Setup

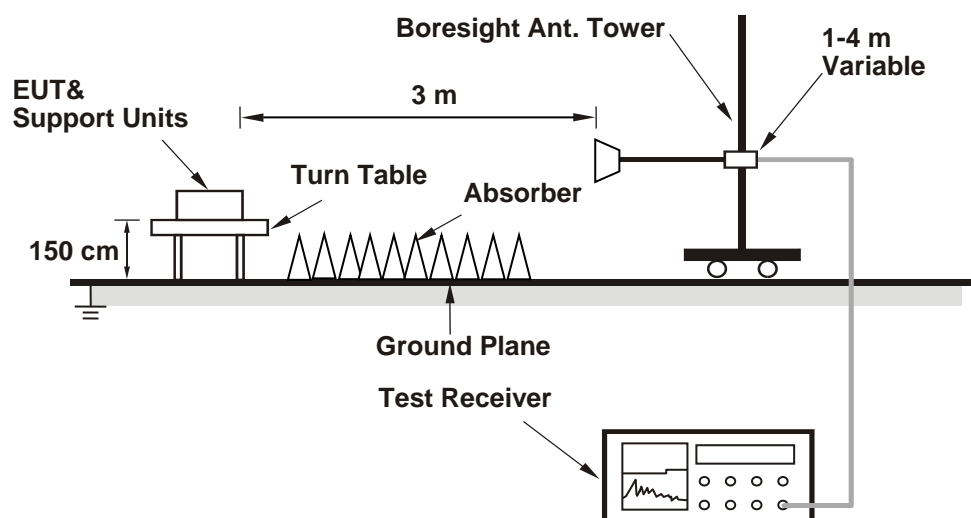

For the actual test configuration, please refer to the attached file (Test Setup Photo).

6.8.2 Test Procedure

- The EUT was placed on the top of a rotating table 1.5 meters above the ground at 3 meter chamber room for test. The table was rotated 360 degrees to determine the position of the highest radiation.
- The EUT was set 3 meters away from the interference-receiving antenna, which was mounted on the top of a variable-height antenna tower.
- The height of antenna is varied from one meter to four meters above the ground to determine the maximum value of the field strength. Both horizontal and vertical polarizations of the antenna are set to make the measurement.
- For each suspected emission, the EUT was arranged to its worst case and then the antenna was tuned to heights from 1 meter to 4 meters and the rotatable table was turned from 0 degrees to 360 degrees to find the maximum reading.
- The test-receiver system was set to peak and average detects function and specified bandwidth with maximum hold mode when the test frequency is above 1 GHz. If the peak reading value also meets average limit, measurement with the average detector is unnecessary.

Notes:

- The resolution bandwidth of test receiver/spectrum analyzer is 1 MHz and the video bandwidth is 3 MHz for Peak detection (PK) and Average detection (AV) at frequency above 1 GHz.
- For fundamental and harmonic signal measurement, the resolution bandwidth of test receiver/spectrum analyzer is 1 MHz and the video bandwidth is $\geq 1/T$ (Duty cycle $< 98\%$) or 10 Hz (Duty cycle $\geq 98\%$) for Average detection (AV) at frequency above 1 GHz.
- All modes of operation were investigated and the worst-case emissions are reported.

7 Test Results of Test Item

7.1 RF Output Power

Input Power:	120 Vac, 60 Hz	Environmental Conditions:	25°C, 60% RH	Tested By:	Katina Lu
--------------	----------------	---------------------------	--------------	------------	-----------

802.11a CDD

Chan.	Chan. Freq. (MHz)	Average Power (dBm)				Total Power (mW)	Total Power (dBm)	Power Limit (dBm)	Test Result
		Chain 0	Chain 1	Chain 2	Chain 3				
36	5180	22.34	22.53	22.53	23.71	764.48	28.83	30	Pass
40	5200	23.60	23.80	23.56	24.24	961.417	29.83	30	Pass
48	5240	22.57	22.71	22.49	23.66	777.048	28.90	30	Pass
149	5745	23.24	23.46	21.75	24.03	835.236	29.22	30	Pass
157	5785	23.27	23.33	21.54	23.71	805.127	29.06	30	Pass
165	5825	23.28	23.05	21.08	23.55	769.348	28.86	30	Pass

Notes:

1. Directional gain is the maximum gain of antennas.
2. For U-NII-1, the directional gain is 5.3 dBi < 6 dBi, so the output power limit shall not be reduced.
3. For U-NII-3, the directional gain is 5.2 dBi < 6 dBi, so the output power limit shall not be reduced.

802.11ac (VHT20) CDD

Chan.	Chan. Freq. (MHz)	Average Power (dBm)				Total Power (mW)	Total Power (dBm)	Power Limit (dBm)	Test Result
		Chain 0	Chain 1	Chain 2	Chain 3				
36	5180	20.74	21.05	20.54	21.62	504.378	27.03	30	Pass
40	5200	21.92	22.32	22.24	23.10	697.873	28.44	30	Pass
48	5240	21.94	22.36	22.13	23.21	701.218	28.46	30	Pass
149	5745	22.38	23.25	21.75	23.95	782.267	28.93	30	Pass
157	5785	22.28	23.53	21.75	23.86	787.312	28.96	30	Pass
165	5825	22.19	22.95	21.36	23.63	730.267	28.63	30	Pass

Notes:

1. Directional gain is the maximum gain of antennas.
2. For U-NII-1, the directional gain is 5.3 dBi < 6 dBi, so the output power limit shall not be reduced.
3. For U-NII-3, the directional gain is 5.2 dBi < 6 dBi, so the output power limit shall not be reduced.

802.11ac (VHT40) CDD

Chan.	Chan. Freq. (MHz)	Average Power (dBm)				Total Power (mW)	Total Power (dBm)	Power Limit (dBm)	Test Result
		Chain 0	Chain 1	Chain 2	Chain 3				
38	5190	18.68	18.73	18.64	19.67	314.232	24.97	30	Pass
46	5230	21.55	21.57	21.25	22.42	594.373	27.74	30	Pass
151	5755	22.57	23.45	21.63	24.54	832.019	29.20	30	Pass
159	5795	21.98	23.19	22.12	24.28	797.057	29.01	30	Pass

Notes:

1. Directional gain is the maximum gain of antennas.
2. For U-NII-1, the maximum gain is 5.3 dBi < 6 dBi, so the output power limit shall not be reduced.
3. For U-NII-3, the maximum gain is 5.2 dBi < 6 dBi, so the output power limit shall not be reduced.

802.11ac (VHT80) CDD

Chan.	Chan. Freq. (MHz)	Average Power (dBm)				Total Power (mW)	Total Power (dBm)	Power Limit (dBm)	Test Result
		Chain 0	Chain 1	Chain 2	Chain 3				
42	5210	18.48	18.45	18.25	19.48	296.003	24.71	30	Pass
155	5775	19.82	20.46	19.44	21.21	427.145	26.31	30	Pass

Notes:

1. Directional gain is the maximum gain of antennas.
2. For U-NII-1, the maximum gain is 5.3 dBi < 6 dBi, so the output power limit shall not be reduced.
3. For U-NII-3, the maximum gain is 5.2 dBi < 6 dBi, so the output power limit shall not be reduced.

802.11ax (HE20) CDD

Chan.	Chan. Freq. (MHz)	Average Power (dBm)				Total Power (mW)	Total Power (dBm)	Power Limit (dBm)	Test Result
		Chain 0	Chain 1	Chain 2	Chain 3				
36	5180	21.03	21.25	20.80	21.83	532.749	27.27	30	Pass
40	5200	22.15	22.61	22.52	23.33	740.375	28.69	30	Pass
48	5240	22.16	22.58	22.38	23.50	742.425	28.71	30	Pass
149	5745	22.62	23.52	22.02	24.17	828.152	29.18	30	Pass
157	5785	22.52	23.81	21.97	24.12	834.709	29.22	30	Pass
165	5825	22.41	23.19	21.61	23.91	773.544	28.88	30	Pass

Notes:

1. Directional gain is the maximum gain of antennas.
2. For U-NII-1, the directional gain is 5.3 dBi < 6 dBi, so the output power limit shall not be reduced.
3. For U-NII-3, the directional gain is 5.2 dBi < 6 dBi, so the output power limit shall not be reduced.

802.11ax (HE40) CDD

Chan.	Chan. Freq. (MHz)	Average Power (dBm)				Total Power (mW)	Total Power (dBm)	Power Limit (dBm)	Test Result
		Chain 0	Chain 1	Chain 2	Chain 3				
38	5190	18.96	19.03	18.91	19.87	333.543	25.23	30	Pass
46	5230	21.83	21.86	21.45	22.67	630.431	28.00	30	Pass
151	5755	22.82	23.66	21.88	24.77	877.786	29.43	30	Pass
159	5795	22.25	23.43	22.33	24.53	842.966	29.26	30	Pass

Notes:

1. Directional gain is the maximum gain of antennas.
2. For U-NII-1, the maximum gain is 5.3 dBi < 6 dBi, so the output power limit shall not be reduced.
3. For U-NII-3, the maximum gain is 5.2 dBi < 6 dBi, so the output power limit shall not be reduced.

802.11ax (HE80) CDD

Chan.	Chan. Freq. (MHz)	Average Power (dBm)				Total Power (mW)	Total Power (dBm)	Power Limit (dBm)	Test Result
		Chain 0	Chain 1	Chain 2	Chain 3				
42	5210	18.78	18.66	18.46	19.72	312.862	24.95	30	Pass
155	5775	20.09	20.68	19.72	21.45	452.437	26.56	30	Pass

Notes:

1. Directional gain is the maximum gain of antennas.
2. For U-NII-1, the maximum gain is 5.3 dBi < 6 dBi, so the output power limit shall not be reduced.
3. For U-NII-3, the maximum gain is 5.2 dBi < 6 dBi, so the output power limit shall not be reduced.

802.11ac (VHT20) Beamforming

Chan.	Chan. Freq. (MHz)	Average Power (dBm)				Total Power (mW)	Total Power (dBm)	Power Limit (dBm)	Test Result
		Chain 0	Chain 1	Chain 2	Chain 3				
36	5180	20.74	21.05	20.54	21.62	504.378	27.03	30	Pass
40	5200	21.92	22.32	22.24	23.10	697.873	28.44	30	Pass
48	5240	21.94	22.36	22.13	23.21	701.218	28.46	30	Pass
149	5745	22.38	23.25	21.75	23.95	782.267	28.93	30	Pass
157	5785	22.28	23.53	21.75	23.86	787.312	28.96	30	Pass
165	5825	22.19	22.95	21.36	23.63	730.267	28.63	30	Pass

Notes:

1. Directional gain is the measured value according to KDB 662911 D03 Method of MIMO Antenna Gain Measurement.
2. For U-NII-1, the directional gain is 5.52 dBi < 6 dBi, so the output power limit shall not be reduced.
3. For U-NII-3, the directional gain is 5.53 dBi < 6 dBi, so the output power limit shall not be reduced.

802.11ac (VHT40) Beamforming

Chan.	Chan. Freq. (MHz)	Average Power (dBm)				Total Power (mW)	Total Power (dBm)	Power Limit (dBm)	Test Result
		Chain 0	Chain 1	Chain 2	Chain 3				
38	5190	18.68	18.73	18.64	19.67	314.232	24.97	30	Pass
46	5230	21.55	21.57	21.25	22.42	594.373	27.74	30	Pass
151	5755	22.57	23.45	21.63	24.54	832.019	29.20	30	Pass
159	5795	21.98	23.19	22.12	24.28	797.057	29.01	30	Pass

Notes:

1. Directional gain is the measured value according to KDB 662911 D03 Method of MIMO Antenna Gain Measurement.
2. For U-NII-1, the directional gain is 5.52 dBi < 6 dBi, so the output power limit shall not be reduced.
3. For U-NII-3, the directional gain is 5.53 dBi < 6 dBi, so the output power limit shall not be reduced.

802.11ac (VHT80) Beamforming

Chan.	Chan. Freq. (MHz)	Average Power (dBm)				Total Power (mW)	Total Power (dBm)	Power Limit (dBm)	Test Result
		Chain 0	Chain 1	Chain 2	Chain 3				
42	5210	18.48	18.45	18.25	19.48	296.003	24.71	30	Pass
155	5775	19.82	20.46	19.44	21.21	427.145	26.31	30	Pass

Notes:

1. Directional gain is the measured value according to KDB 662911 D03 Method of MIMO Antenna Gain Measurement.
2. For U-NII-1, the directional gain is 5.52 dBi < 6 dBi, so the output power limit shall not be reduced.
3. For U-NII-3, the directional gain is 5.53 dBi < 6 dBi, so the output power limit shall not be reduced.

802.11ax (HE20) Beamforming

Chan.	Chan. Freq. (MHz)	Average Power (dBm)				Total Power (mW)	Total Power (dBm)	Power Limit (dBm)	Test Result
		Chain 0	Chain 1	Chain 2	Chain 3				
36	5180	21.03	21.25	20.80	21.83	532.749	27.27	30	Pass
40	5200	22.15	22.61	22.52	23.33	740.375	28.69	30	Pass
48	5240	22.16	22.58	22.38	23.50	742.425	28.71	30	Pass
149	5745	22.62	23.52	22.02	24.17	828.152	29.18	30	Pass
157	5785	22.52	23.81	21.97	24.12	834.709	29.22	30	Pass
165	5825	22.41	23.19	21.61	23.91	773.544	28.88	30	Pass

Notes:

1. Directional gain is the measured value according to KDB 662911 D03 Method of MIMO Antenna Gain Measurement.
2. For U-NII-1, the directional gain is 5.52 dBi < 6 dBi, so the output power limit shall not be reduced.
3. For U-NII-3, the directional gain is 5.53 dBi < 6 dBi, so the output power limit shall not be reduced.

802.11ax (HE40) Beamforming

Chan.	Chan. Freq. (MHz)	Average Power (dBm)				Total Power (mW)	Total Power (dBm)	Power Limit (dBm)	Test Result
		Chain 0	Chain 1	Chain 2	Chain 3				
38	5190	18.96	19.03	18.91	19.87	333.543	25.23	30	Pass
46	5230	21.83	21.86	21.45	22.67	630.431	28.00	30	Pass
151	5755	22.82	23.66	21.88	24.77	877.786	29.43	30	Pass
159	5795	22.25	23.43	22.33	24.53	842.966	29.26	30	Pass

Notes:

1. Directional gain is the measured value according to KDB 662911 D03 Method of MIMO Antenna Gain Measurement.
2. For U-NII-1, the directional gain is 5.52 dBi < 6 dBi, so the output power limit shall not be reduced.
3. For U-NII-3, the directional gain is 5.53 dBi < 6 dBi, so the output power limit shall not be reduced.

802.11ax (HE80) Beamforming

Chan.	Chan. Freq. (MHz)	Average Power (dBm)				Total Power (mW)	Total Power (dBm)	Power Limit (dBm)	Test Result
		Chain 0	Chain 1	Chain 2	Chain 3				
42	5210	18.78	18.66	18.46	19.72	312.862	24.95	30	Pass
155	5775	20.09	20.68	19.72	21.45	452.437	26.56	30	Pass

Notes:

1. Directional gain is the measured value according to KDB 662911 D03 Method of MIMO Antenna Gain Measurement.
2. For U-NII-1, the directional gain is 5.52 dBi < 6 dBi, so the output power limit shall not be reduced.
3. For U-NII-3, the directional gain is 5.53 dBi < 6 dBi, so the output power limit shall not be reduced.

7.2 Power Spectral Density

Input Power:	120 Vac, 60 Hz	Environmental Conditions:	25°C, 60% RH	Tested By:	Katina Lu
--------------	----------------	---------------------------	--------------	------------	-----------

802.11a

Chan.	Chan. Freq. (MHz)	PSD (dBm/MHz)				Total PSD (dBm/MHz)	Max. PSD Limit (dBm/MHz)	Test Result
		Chain 0	Chain 1	Chain 2	Chain 3			
36	5180	10.52	10.93	10.47	11.43	16.88	17	Pass
40	5200	10.77	10.86	10.60	11.50	16.97	17	Pass
48	5240	9.95	10.78	10.04	11.27	16.57	17	Pass

Notes:

1. Method E) 2) a) of power density measurement of KDB 662911 is using for calculating total power density. Total power density is summing entire spectra across corresponding frequency bins on the various outputs by computer.
2. Directional gain is the measured value according to KDB 662911 D03 Method of MIMO Antenna Gain Measurement.
3. For U-NII-1, the directional gain is 5.52 dBi < 6dBi, so the power density limit shall not be reduced.

802.11ax (HE20)

Chan.	Chan. Freq. (MHz)	PSD (dBm/MHz)				Total PSD (dBm/MHz)	Max. PSD Limit (dBm/MHz)	Test Result
		Chain 0	Chain 1	Chain 2	Chain 3			
36	5180	8.45	8.89	8.62	9.64	14.95	17	Pass
40	5200	9.95	10.14	10.10	11.06	16.36	17	Pass
48	5240	9.91	9.96	9.91	11.12	16.28	17	Pass

Notes:

1. Method E) 2) a) of power density measurement of KDB 662911 is using for calculating total power density. Total power density is summing entire spectra across corresponding frequency bins on the various outputs by computer.
2. Directional gain is the measured value according to KDB 662911 D03 Method of MIMO Antenna Gain Measurement.
3. For U-NII-1, the directional gain is 5.52 dBi < 6dBi, so the power density limit shall not be reduced.

802.11ax (HE40)

Chan.	Chan. Freq. (MHz)	PSD (dBm/MHz)				Total PSD (dBm/MHz)	Max. PSD Limit (dBm/MHz)	Test Result
		Chain 0	Chain 1	Chain 2	Chain 3			
38	5190	3.43	3.55	3.72	4.27	9.78	17	Pass
46	5230	6.35	6.39	6.28	7.37	12.64	17	Pass

Notes:

1. Method E) 2) a) of power density measurement of KDB 662911 is using for calculating total power density. Total power density is summing entire spectra across corresponding frequency bins on the various outputs by computer.
2. Directional gain is the measured value according to KDB 662911 D03 Method of MIMO Antenna Gain Measurement.
3. For U-NII-1, the directional gain is 5.52 dBi < 6dBi, so the power density limit shall not be reduced.

802.11ax (HE80)

Chan.	Chan. Freq. (MHz)	PSD (dBm/MHz)				Total PSD (dBm/MHz)	Max. PSD Limit (dBm/MHz)	Test Result
		Chain 0	Chain 1	Chain 2	Chain 3			
42	5210	0.36	0.38	0.10	1.51	6.64	17	Pass

Notes:

1. Method E) 2) a) of power density measurement of KDB 662911 is using for calculating total power density. Total power density is summing entire spectra across corresponding frequency bins on the various outputs by computer.
2. Directional gain is the measured value according to KDB 662911 D03 Method of MIMO Antenna Gain Measurement.
3. For U-NII-1, the directional gain is 5.52 dBi < 6dBi, so the power density limit shall not be reduced.

802.11a

Chan.	Chan. Freq. (MHz)	PSD (dBm/300kHz)				Total PSD (dBm/300kHz)	Total PSD (dBm/500kHz)	PSD Limit (dBm/500kHz)	Test Result
		Chain 0	Chain 1	Chain 2	Chain 3				
149	5745	6.15	5.46	3.99	6.24	11.57	13.79	30	Pass
157	5785	5.92	5.10	3.92	6.16	11.38	13.60	30	Pass
165	5825	5.57	4.77	3.54	5.65	10.98	13.20	30	Pass

Notes:

1. Method E) 2) b) Measure and sum spectral maxima across the outputs of KDB 662911 is using for calculating total power density.
2. Directional gain is the measured value according to KDB 662911 D03 Method of MIMO Antenna Gain Measurement.
3. For U-NII-3, the directional gain is 5.53 dBi < 6 dBi, so the power density limit shall not be reduced.

802.11ax (HE20)

Chan.	Chan. Freq. (MHz)	PSD (dBm/300kHz)				Total PSD (dBm/300kHz)	Total PSD (dBm/500kHz)	PSD Limit (dBm/500kHz)	Test Result
		Chain 0	Chain 1	Chain 2	Chain 3				
149	5745	4.42	5.47	3.67	5.81	10.94	13.16	30	Pass
157	5785	4.52	4.96	3.76	5.77	10.83	13.05	30	Pass
165	5825	4.38	4.56	3.63	5.29	10.53	12.75	30	Pass

Notes:

1. Method E) 2) b) Measure and sum spectral maxima across the outputs of KDB 662911 is using for calculating total power density.
2. Directional gain is the measured value according to KDB 662911 D03 Method of MIMO Antenna Gain Measurement.
3. For U-NII-3, the directional gain is 5.53 dBi < 6 dBi, so the power density limit shall not be reduced.

802.11ax (HE40)

Chan.	Chan. Freq. (MHz)	PSD (dBm/300kHz)				Total PSD (dBm/300kHz)	Total PSD (dBm/500kHz)	PSD Limit (dBm/500kHz)	Test Result
		Chain 0	Chain 1	Chain 2	Chain 3				
151	5755	2.20	2.69	1.31	3.51	8.52	10.74	30	Pass
159	5795	1.83	2.40	1.13	3.38	8.28	10.50	30	Pass

Notes:

1. Method E) 2) b) Measure and sum spectral maxima across the outputs of KDB 662911 is using for calculating total power density.
2. Directional gain is the measured value according to KDB 662911 D03 Method of MIMO Antenna Gain Measurement.
3. For U-NII-3, the directional gain is 5.53 dBi < 6 dBi, so the power density limit shall not be reduced.

802.11ax (HE80)

Chan.	Chan. Freq. (MHz)	PSD (dBm/300kHz)				Total PSD (dBm/300kHz)	Total PSD (dBm/500kHz)	PSD Limit (dBm/500kHz)	Test Result
		Chain 0	Chain 1	Chain 2	Chain 3				
155	5775	-3.53	-3.00	-4.09	-2.05	2.92	5.14	30	Pass

Notes:

1. Method E) 2) b) Measure and sum spectral maxima across the outputs of KDB 662911 is using for calculating total power density.
2. Directional gain is the measured value according to KDB 662911 D03 Method of MIMO Antenna Gain Measurement.
3. For U-NII-3, the directional gain is 5.53 dBi < 6 dBi, so the power density limit shall not be reduced.

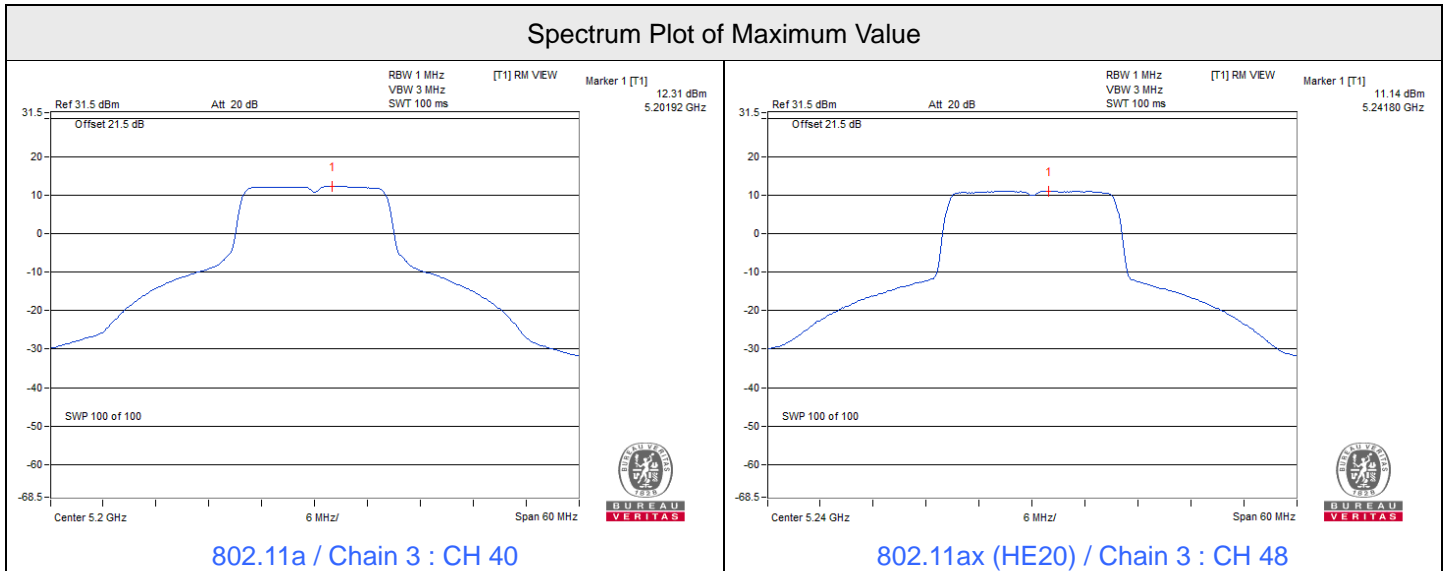



Spectrum Plot of Maximum Value

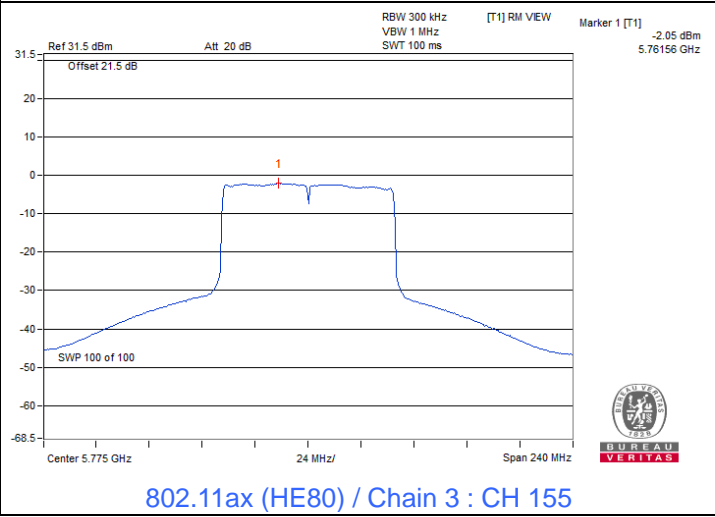
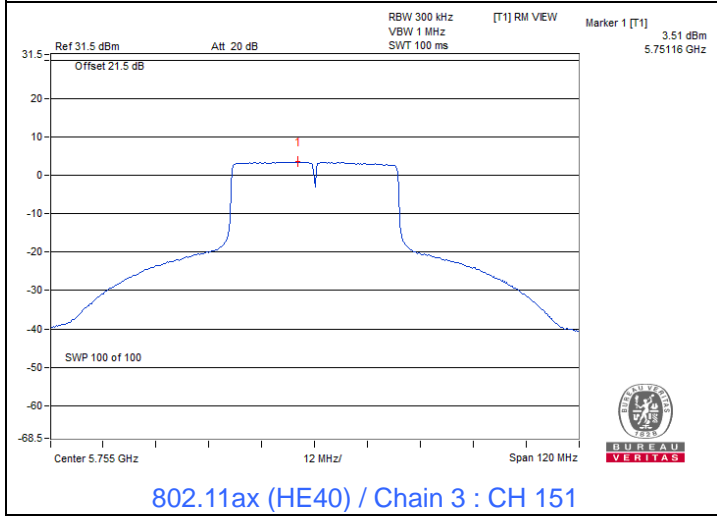
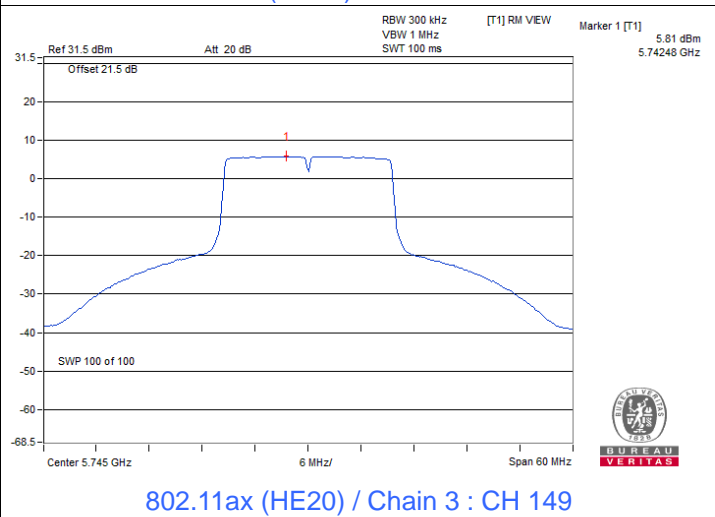
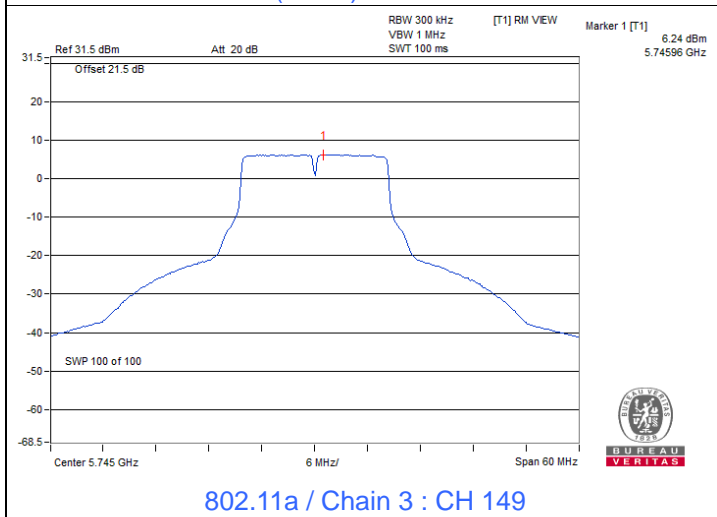
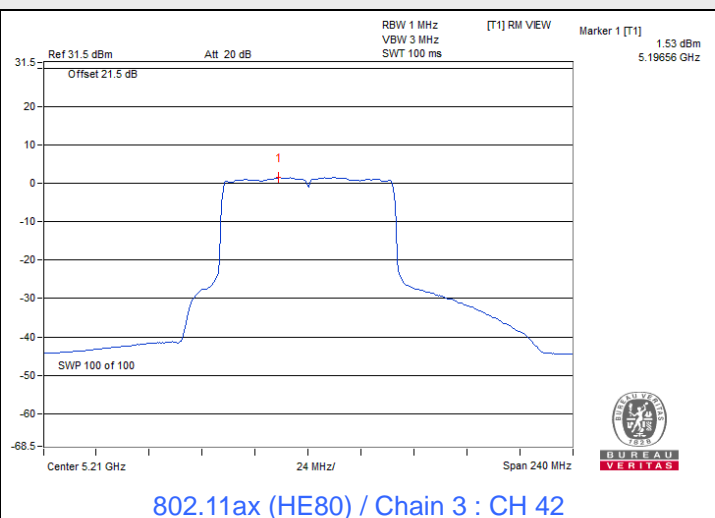
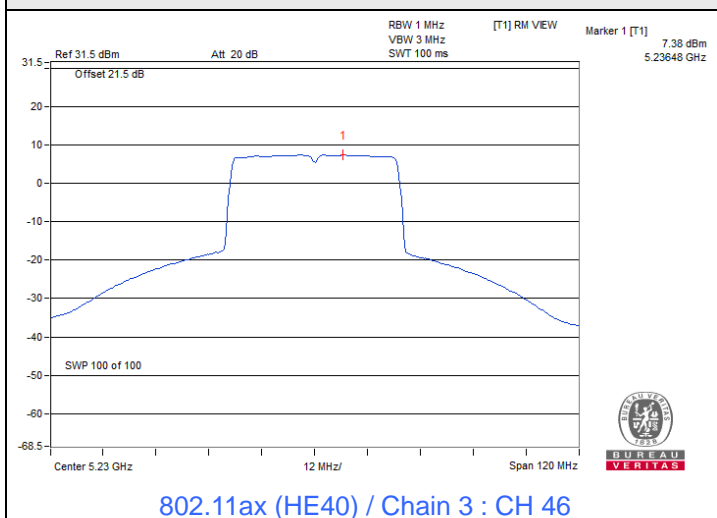

7.3 6 dB Bandwidth

Input Power:	120 Vac, 60 Hz	Environmental Conditions:	25°C, 60% RH	Tested By:	Katina Lu
--------------	----------------	---------------------------	--------------	------------	-----------

802.11a

Channel	Frequency (MHz)	6 dB Bandwidth (MHz)				Minimum Limit (MHz)	Test Result
		Chain 0	Chain 1	Chain 2	Chain 3		
149	5745	16.39	16.39	16.41	16.42	0.5	Pass
157	5785	16.42	16.41	16.41	16.41	0.5	Pass
165	5825	16.42	16.41	16.43	16.42	0.5	Pass

802.11ax (HE20)

Channel	Frequency (MHz)	6 dB Bandwidth (MHz)				Minimum Limit (MHz)	Test Result
		Chain 0	Chain 1	Chain 2	Chain 3		
149	5745	19.05	18.94	18.98	18.98	0.5	Pass
157	5785	19.08	19.04	19.04	19.01	0.5	Pass
165	5825	19.02	19.02	19.04	19.02	0.5	Pass

802.11ax (HE40)

Channel	Frequency (MHz)	6 dB Bandwidth (MHz)				Minimum Limit (MHz)	Test Result
		Chain 0	Chain 1	Chain 2	Chain 3		
151	5755	37.95	37.89	38.05	37.86	0.5	Pass
159	5795	38.02	37.61	37.83	37.96	0.5	Pass

802.11ax (HE80)

Channel	Frequency (MHz)	6 dB Bandwidth (MHz)				Minimum Limit (MHz)	Test Result
		Chain 0	Chain 1	Chain 2	Chain 3		
155	5775	77.99	77.71	77.78	77.46	0.5	Pass



Spectrum Plot of Minimum Value

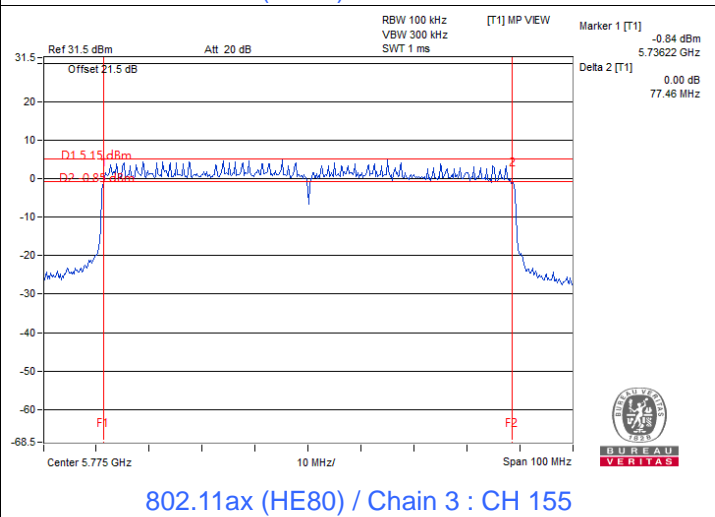
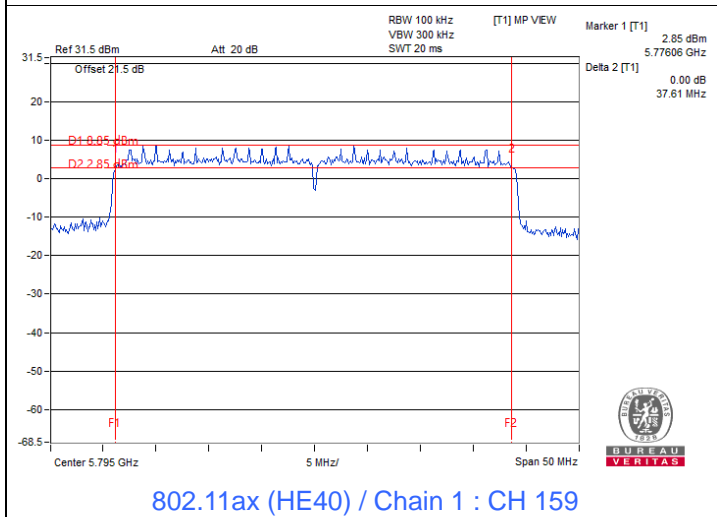
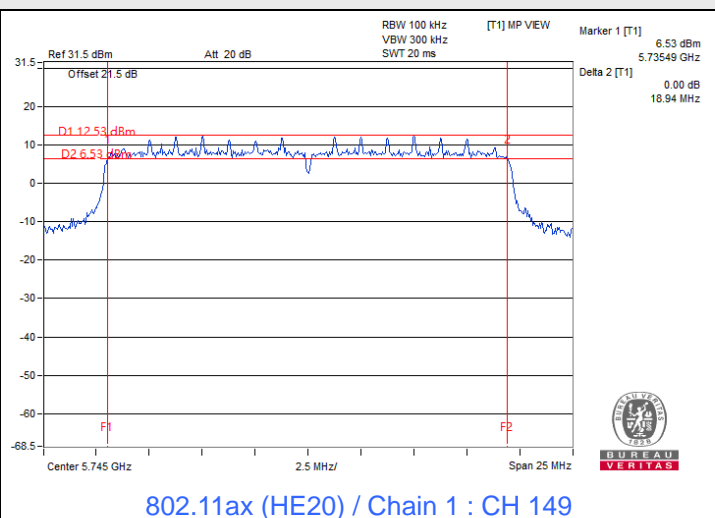
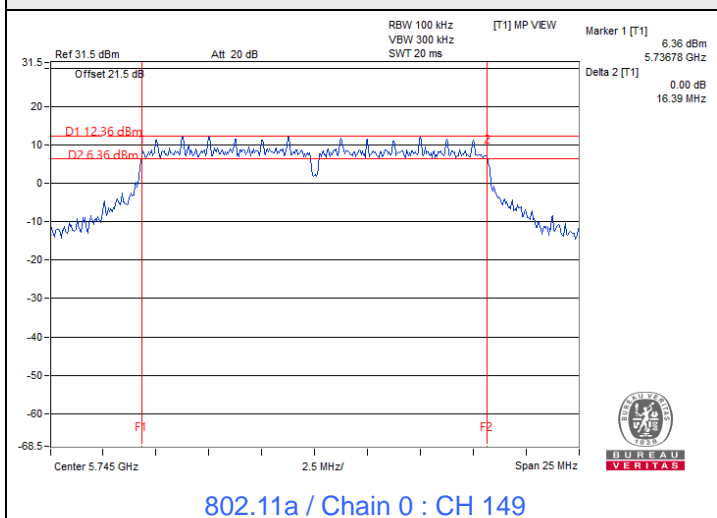

7.4 Occupied Bandwidth

Input Power:	120 Vac, 60 Hz	Environmental Conditions:	25°C, 60% RH	Tested By:	Katina Lu
--------------	----------------	---------------------------	--------------	------------	-----------

802.11a

Channel	Frequency (MHz)	Occupied Bandwidth (MHz)			
		Chain 0	Chain 1	Chain 2	Chain 3
36	5180	17.40	17.52	17.28	18.24
40	5200	18.72	18.24	17.64	22.56
48	5240	17.52	18.12	17.40	19.68
149	5745	19.32	18.48	17.52	17.76
157	5785	20.88	19.08	17.64	19.08
165	5825	23.64	19.20	17.64	19.32

802.11ax (HE20)

Channel	Frequency (MHz)	Occupied Bandwidth (MHz)			
		Chain 0	Chain 1	Chain 2	Chain 3
36	5180	19.32	19.20	19.20	19.20
40	5200	19.32	19.44	19.20	20.04
48	5240	19.32	19.32	19.32	19.80
149	5745	19.32	20.04	19.32	19.32
157	5785	19.56	19.80	19.32	19.92
165	5825	19.80	19.80	19.44	20.40

802.11ax (HE40)

Channel	Frequency (MHz)	Occupied Bandwidth (MHz)			
		Chain 0	Chain 1	Chain 2	Chain 3
38	5190	38.40	38.40	38.40	38.16
46	5230	38.16	38.16	38.16	38.64
151	5755	38.64	39.60	38.16	38.88
159	5795	39.12	42.96	38.64	45.84

802.11ax (HE80)

Channel	Frequency (MHz)	Occupied Bandwidth (MHz)			
		Chain 0	Chain 1	Chain 2	Chain 3
42	5210	77.76	77.76	77.76	77.76
155	5775	77.28	77.28	77.28	77.28



Spectrum Plot of Maximum Value

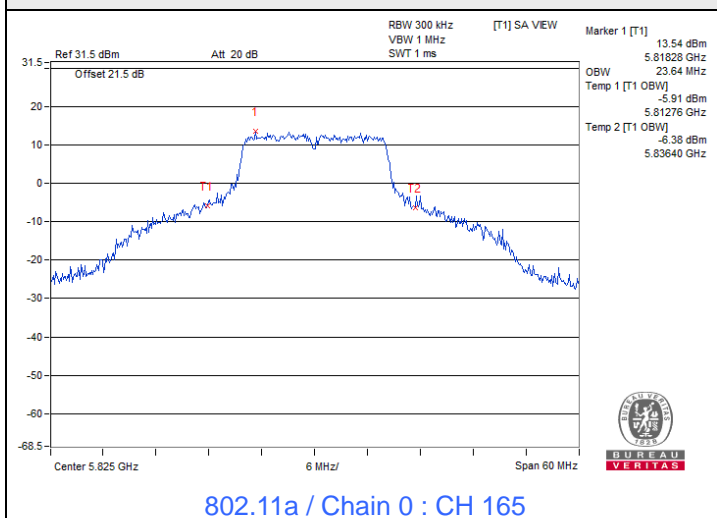

802.11a / Chain 0 : CH 165

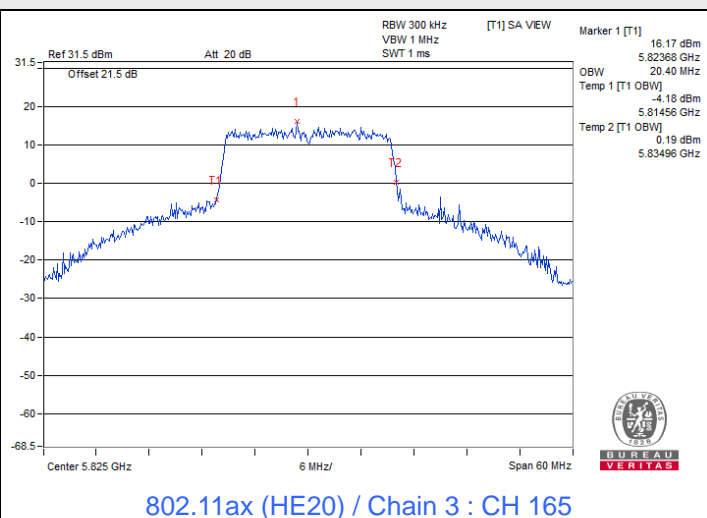

802.11ax (HE20) / Chain 3 : CH 165

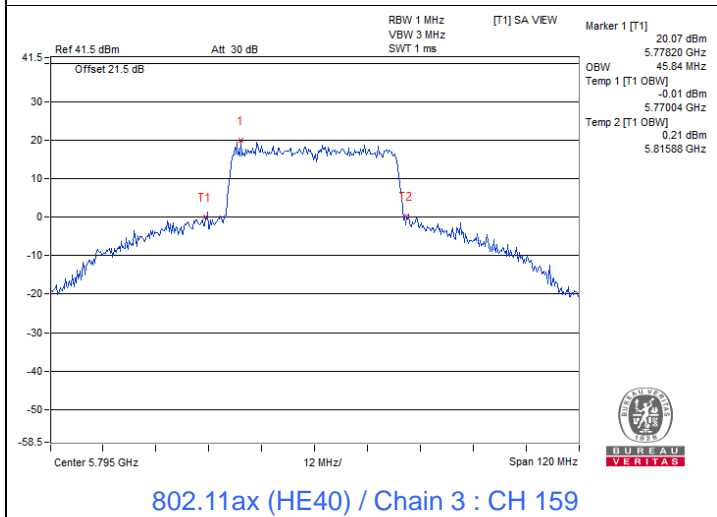

802.11ax (HE40) / Chain 3 : CH 159

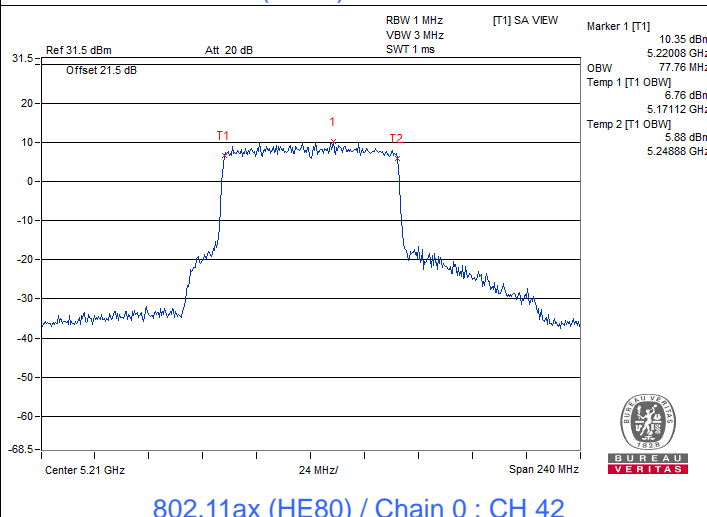

802.11ax (HE80) / Chain 0 : CH 42



Spectrum Plot for nearby DFS band (DFS is required, if 99% OCP straddle into U-NII-2A)

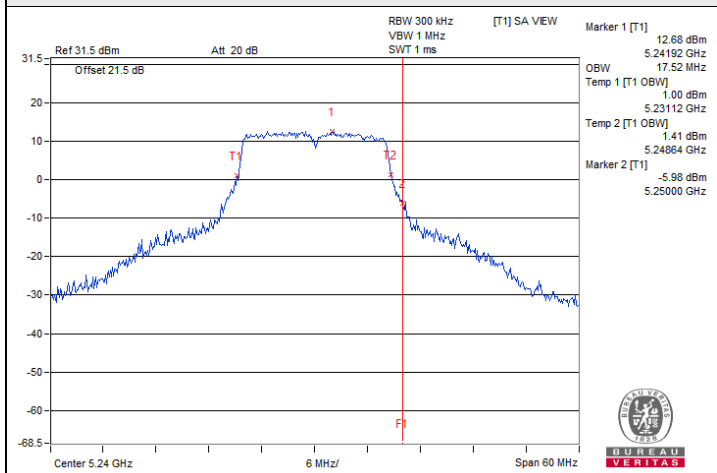

802.11a / Chain 0 : CH 48

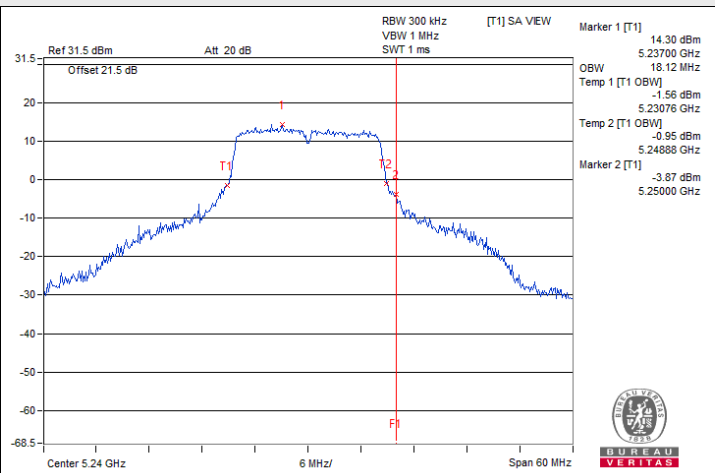

802.11a / Chain 1 : CH 48

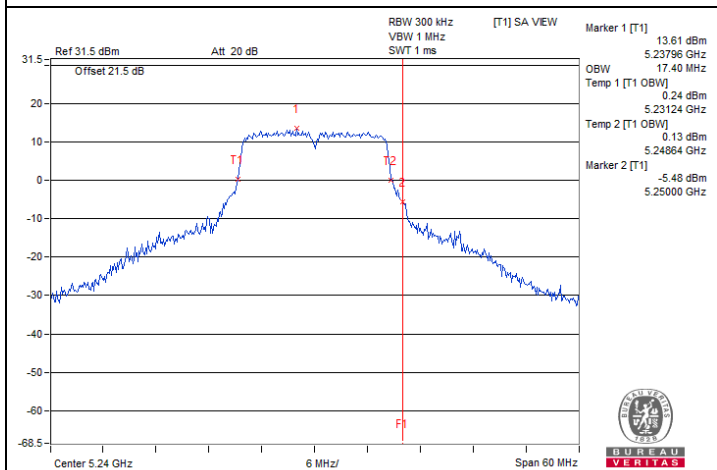

802.11a / Chain 2 : CH 48

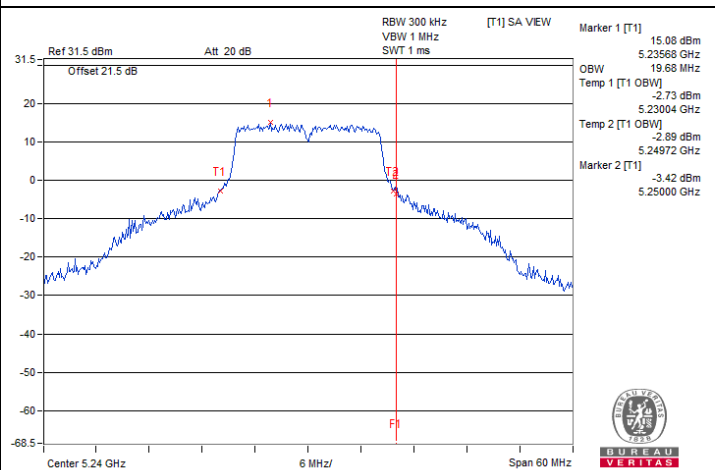

802.11a / Chain 3 : CH 48

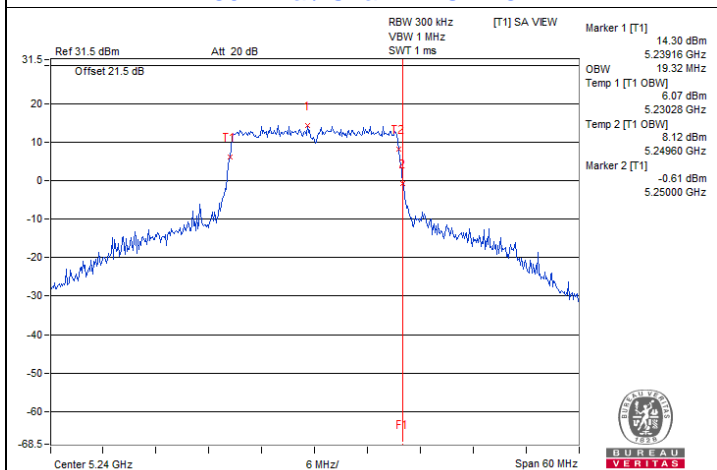

802.11ax (HE20) / Chain 0 : CH 48

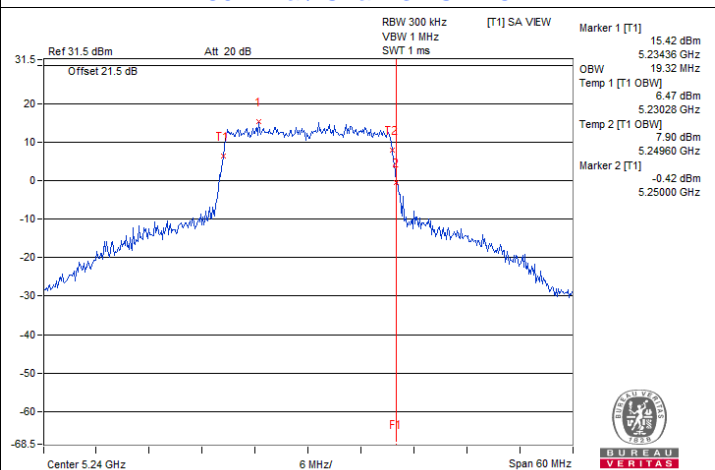

802.11ax (HE20) / Chain 1 : CH 48

Spectrum Plot for nearby DFS band (DFS is required, if 99% OCP straddle into U-NII-2A)

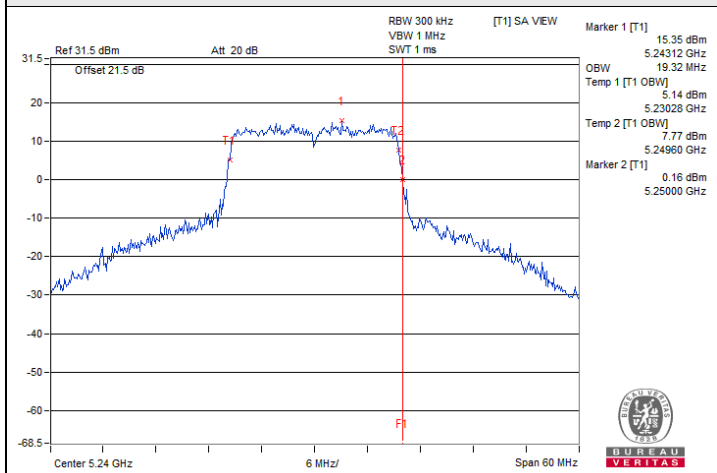

802.11ax (HE20) / Chain 2 : CH 48

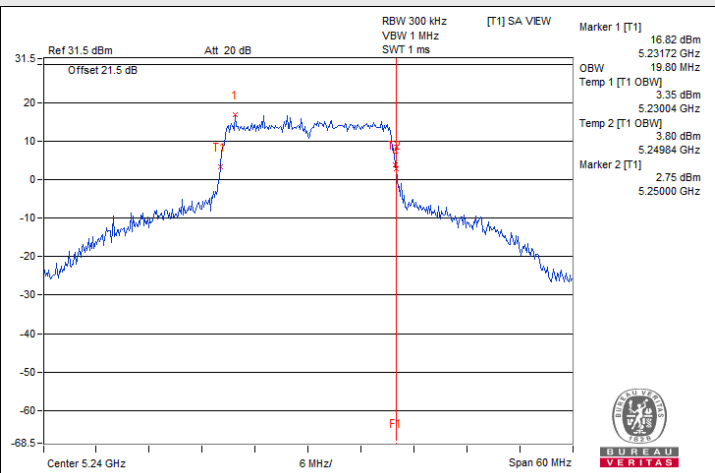

802.11ax (HE20) / Chain 3 : CH 48

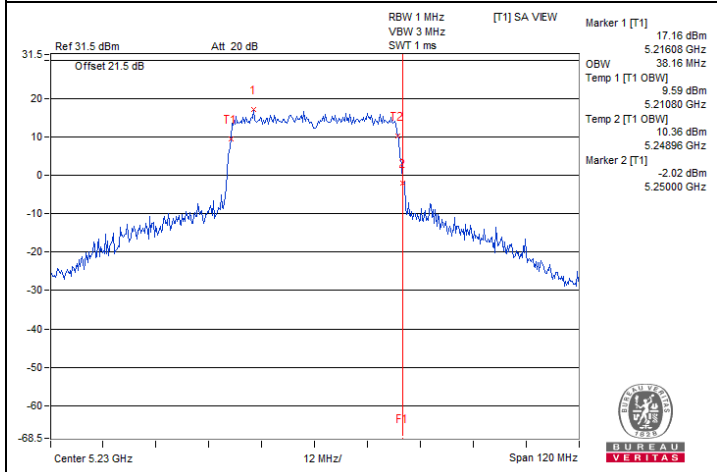

802.11ax (HE40) / Chain 0 : CH 46

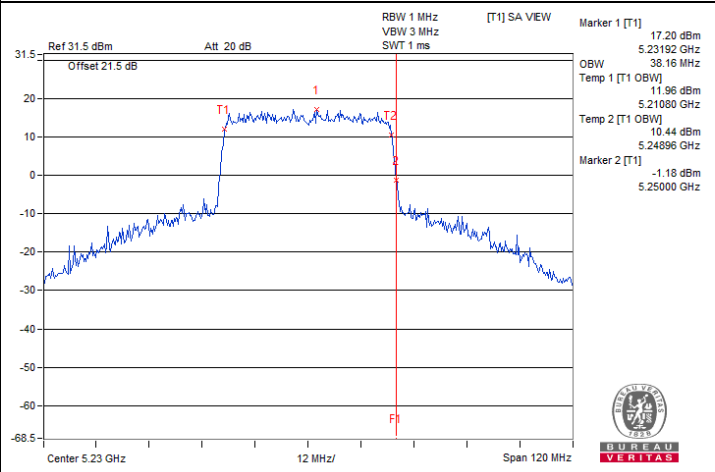

802.11ax (HE40) / Chain 1 : CH 46

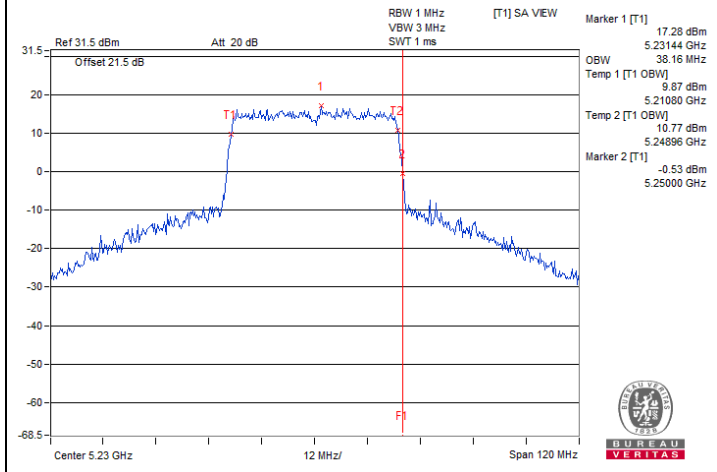

802.11ax (HE40) / Chain 2 : CH 46

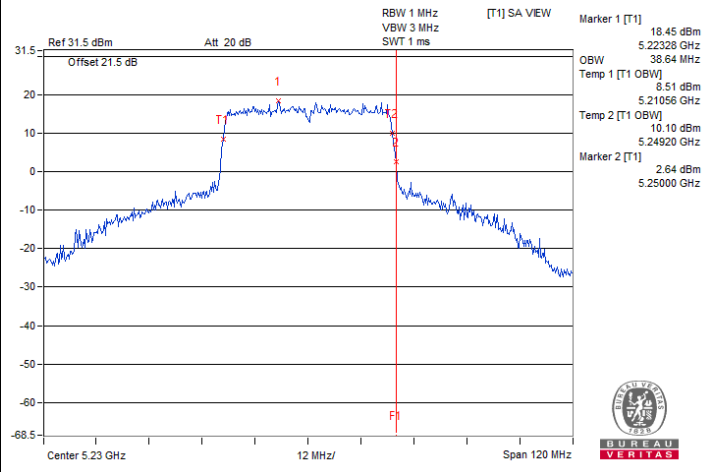

802.11ax (HE40) / Chain 3 : CH 46

Spectrum Plot for nearby DFS band (DFS is required, if 99% OCP straddle into U-NII-2A)

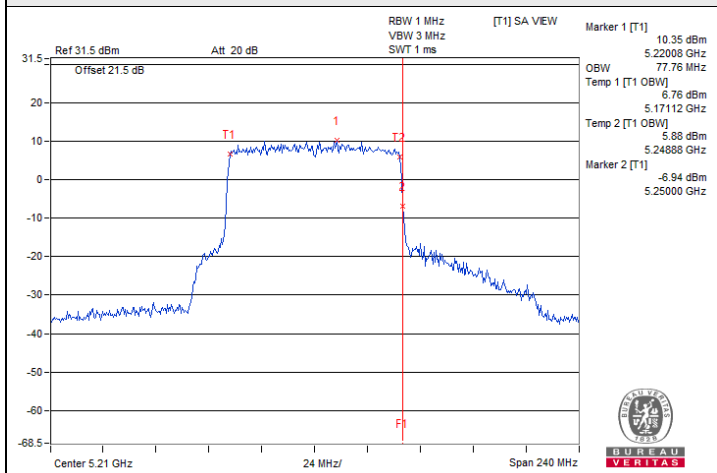

802.11ax (HE80) / Chain 0 : CH 42

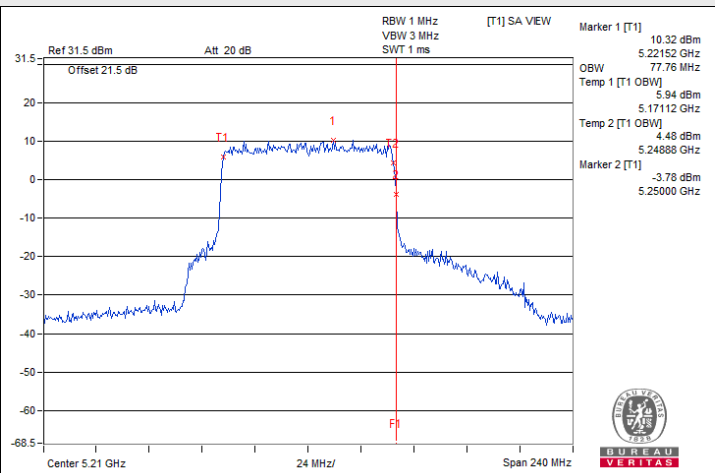

802.11ax (HE80) / Chain 1 : CH 42

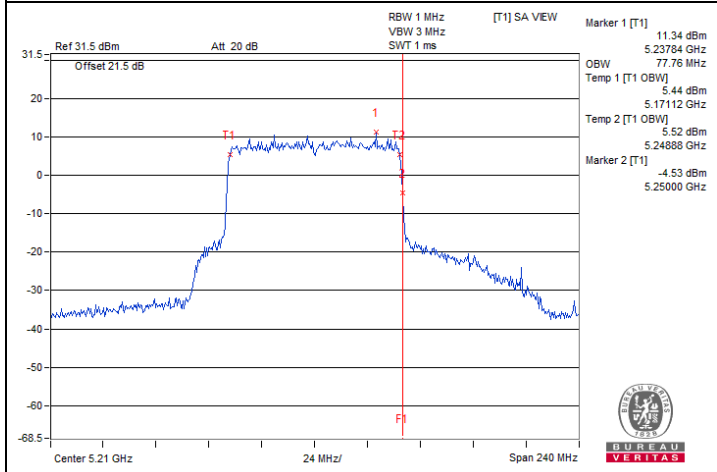

802.11ax (HE80) / Chain 2 : CH 42

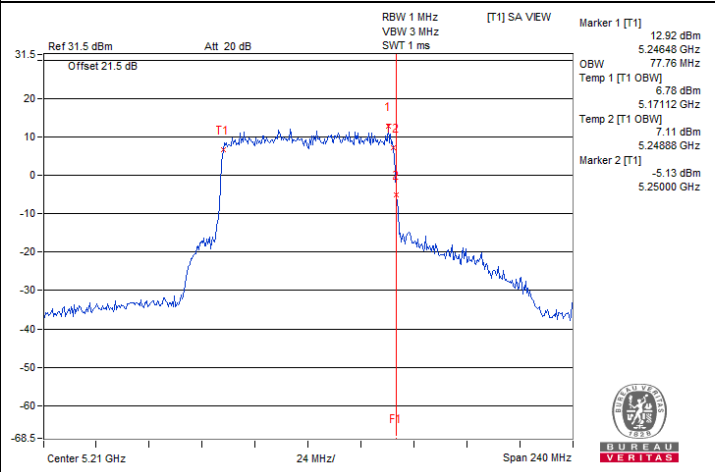

802.11ax (HE80) / Chain 3 : CH 42

Spectrum Plot for nearby DFS band (DFS is required, if 99% OCP straddle into U-NII-2C)

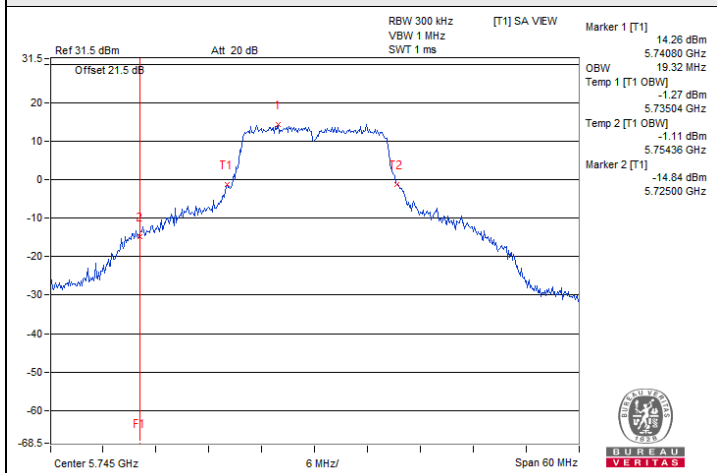
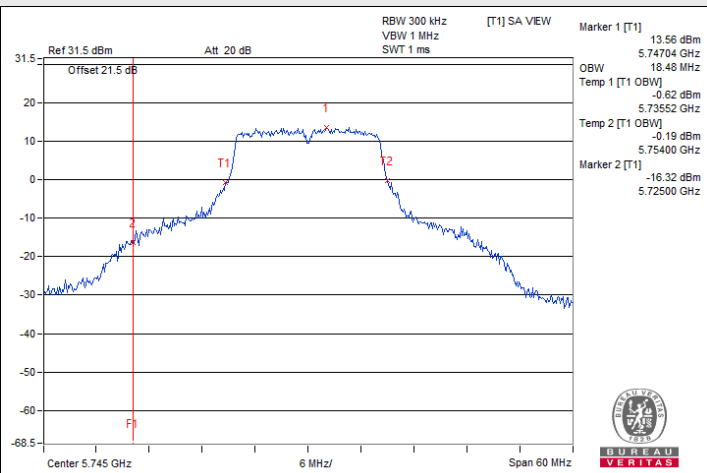
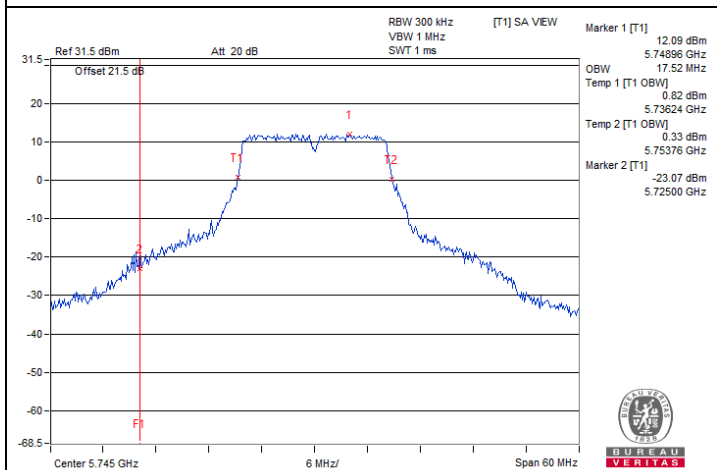
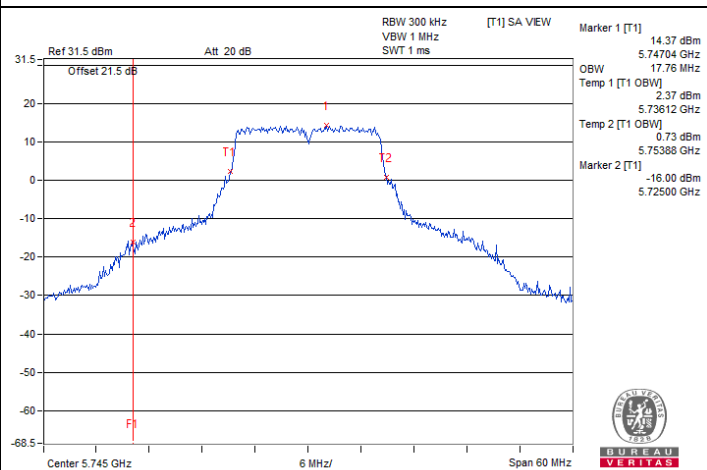
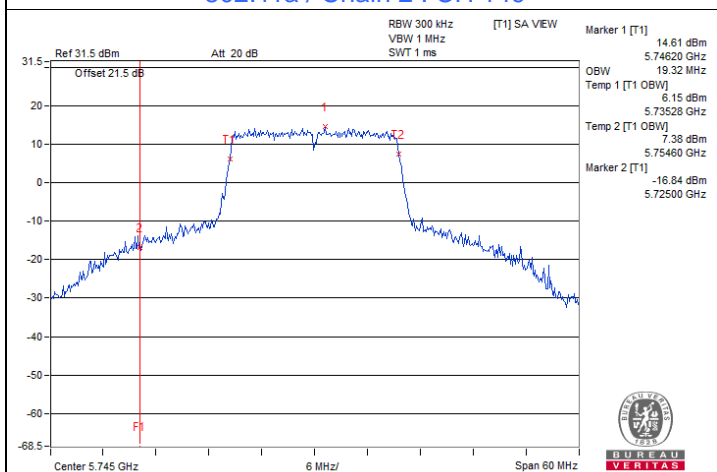
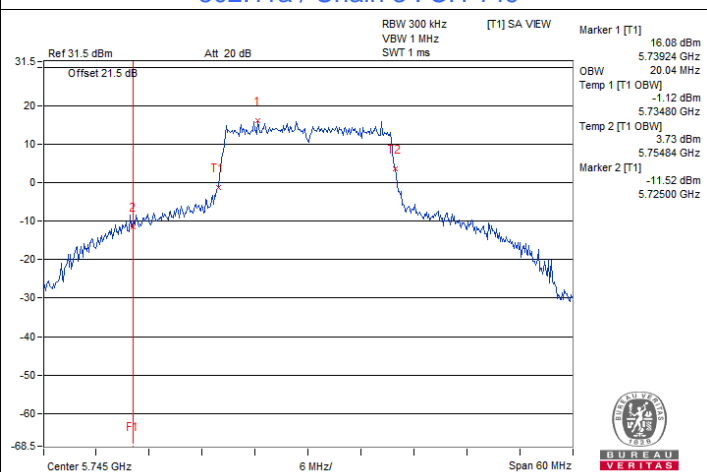
**802.11a / Chain 0 : CH 149****802.11a / Chain 1 : CH 149****802.11a / Chain 2 : CH 149****802.11a / Chain 3 : CH 149****802.11ax (HE20) / Chain 0 : CH 149****802.11ax (HE20) / Chain 1 : CH 149**



Spectrum Plot for nearby DFS band (DFS is required, if 99% OCP straddle into U-NII-2C)

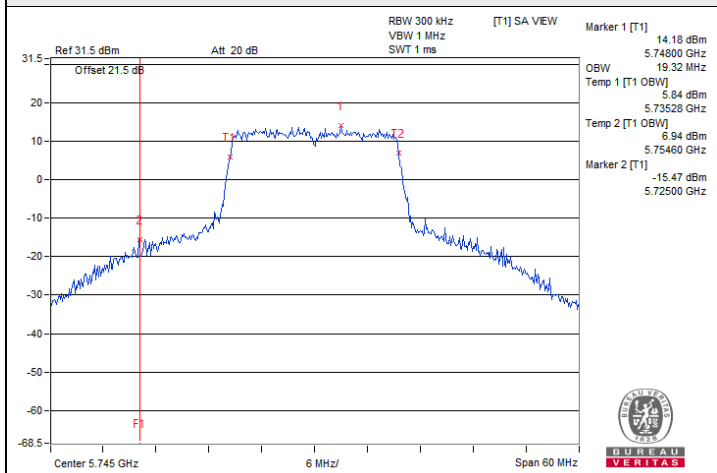

802.11ax (HE20) / Chain 2 : CH 149

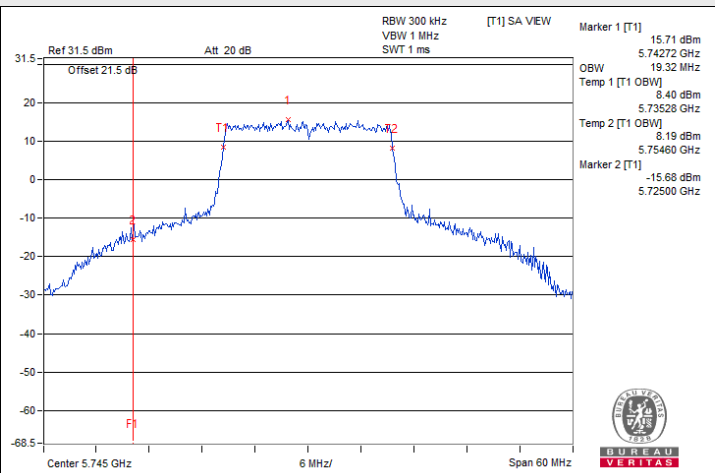

802.11ax (HE20) / Chain 3 : CH 149

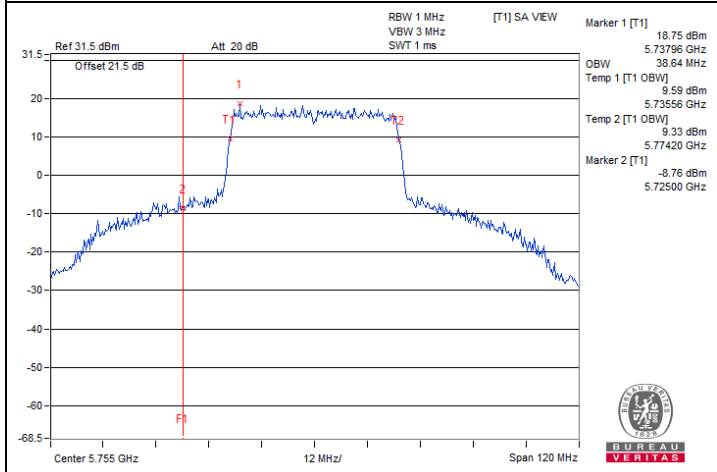

802.11ax (HE40) / Chain 0 : CH 151

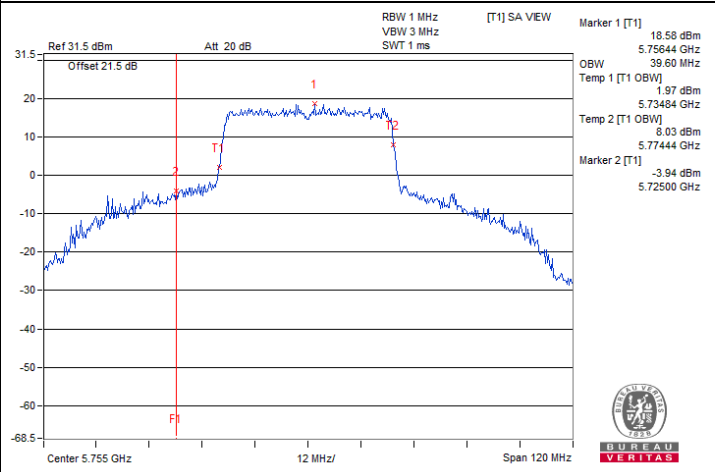

802.11ax (HE40) / Chain 1 : CH 151

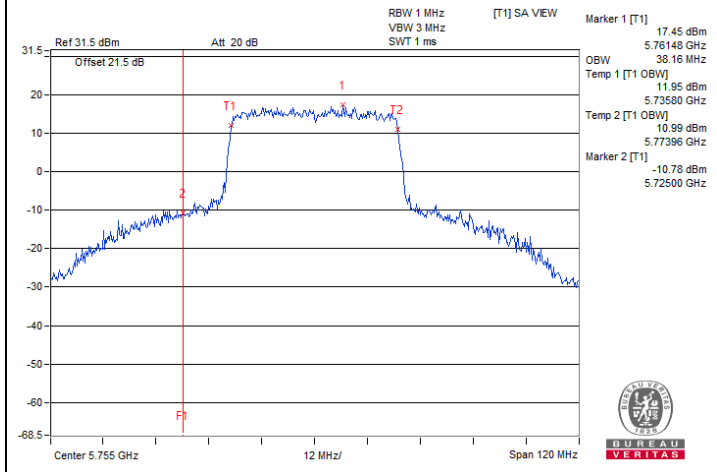

802.11ax (HE40) / Chain 2 : CH 151

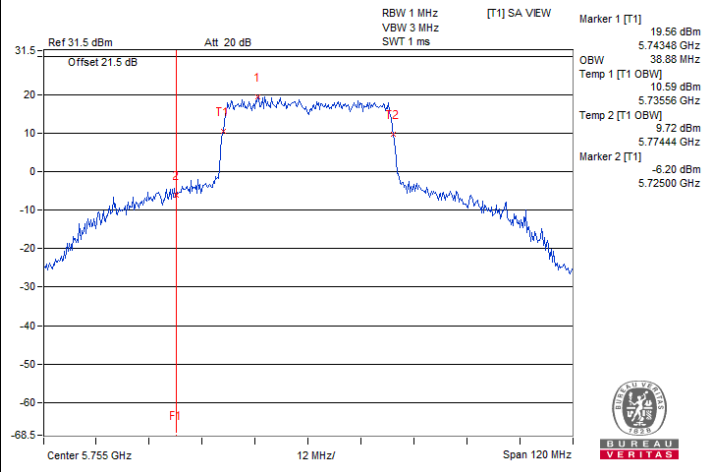

802.11ax (HE40) / Chain 3 : CH 151



Spectrum Plot for nearby DFS band (DFS is required, if 99% OCP straddle into U-NII-2C)

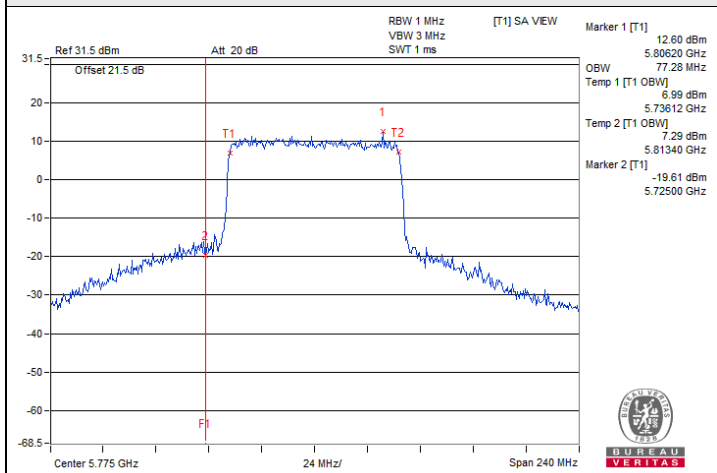

802.11ax (HE80) / Chain 0 : CH 155

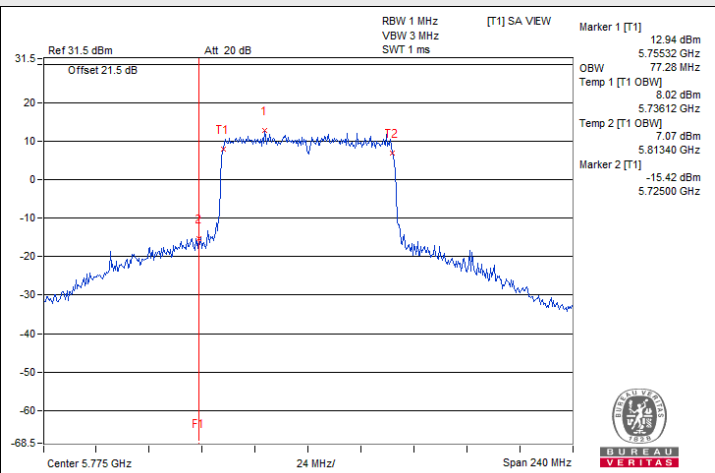

802.11ax (HE80) / Chain 1 : CH 155

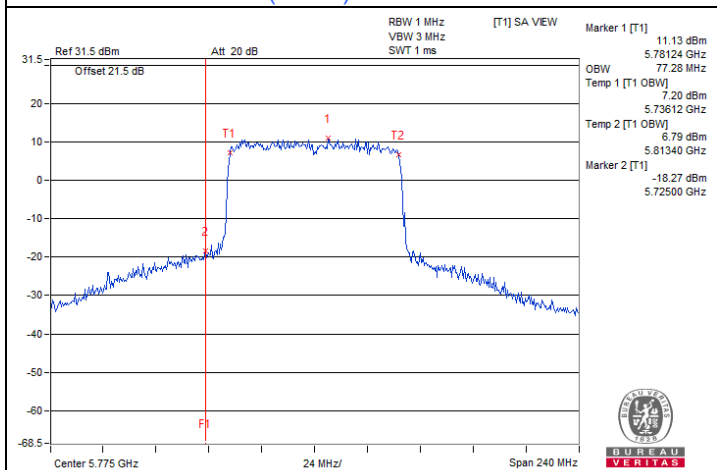

802.11ax (HE80) / Chain 2 : CH 155

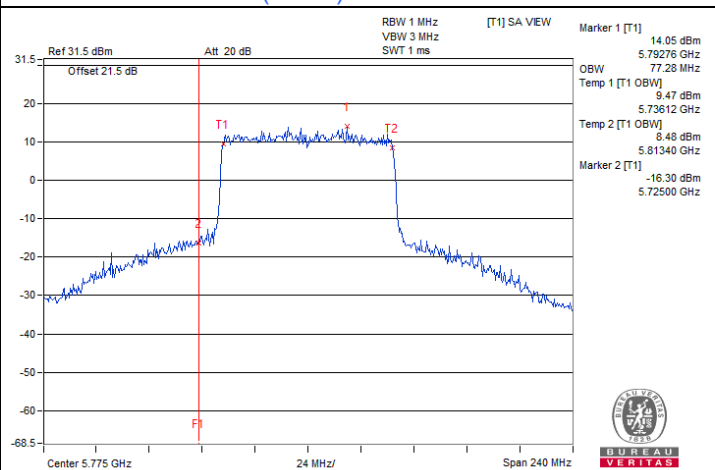

802.11ax (HE80) / Chain 3 : CH 155

7.5 Frequency Stability

Input Power:	120 Vac, 60 Hz	Environmental Conditions:	25°C, 60% RH	Tested By:	Katina Lu
--------------	----------------	---------------------------	--------------	------------	-----------

802.11a

Frequency Stability Versus Temperature									
Operating Frequency: 5180 MHz									
Temp. (°C)	Power Supply (Vac)	0 Minute		2 Minutes		5 Minutes		10 Minutes	
		Measured Frequency (MHz)	Test Result	Measured Frequency (MHz)	Test Result	Measured Frequency (MHz)	Test Result	Measured Frequency (MHz)	Test Result
40	120	5180.0229	Pass	5180.0217	Pass	5180.0186	Pass	5180.0228	Pass
30	120	5180.0093	Pass	5180.0051	Pass	5180.0086	Pass	5180.0086	Pass
20	120	5179.9998	Pass	5180.0026	Pass	5179.9996	Pass	5180.0009	Pass
10	120	5180.0111	Pass	5180.0129	Pass	5180.0115	Pass	5180.0119	Pass
0	120	5179.9762	Pass	5179.9759	Pass	5179.9753	Pass	5179.9771	Pass

Frequency Stability Versus Voltage									
Operating Frequency: 5180 MHz									
Temp. (°C)	Power Supply (Vac)	0 Minute		2 Minutes		5 Minutes		10 Minutes	
		Measured Frequency (MHz)	Test Result	Measured Frequency (MHz)	Test Result	Measured Frequency (MHz)	Test Result	Measured Frequency (MHz)	Test Result
20	138	5180.0075	Pass	5180.0097	Pass	5180.007	Pass	5180.0076	Pass
	120	5179.9998	Pass	5180.0026	Pass	5179.9996	Pass	5180.0009	Pass
	102	5179.9953	Pass	5179.9956	Pass	5179.9971	Pass	5179.9941	Pass

7.6 AC Power Conducted Emissions

RF Mode	802.11a	Channel	CH 40 : 5200 MHz
Frequency Range	150 kHz ~ 30 MHz	Detector Function & Resolution Bandwidth	Quasi-Peak (QP) / Average (AV), 9 kHz
Input Power	120 Vac, 60 Hz	Environmental Conditions	24°C, 68% RH
Tested By	Sampson Chen		

Phase Of Power : Line (L)										
No	Frequency (MHz)	Correction Factor (dB)	Reading Value (dBuV)		Emission Level (dBuV)		Limit (dBuV)		Margin (dB)	
			Q.P.	AV.	Q.P.	AV.	Q.P.	AV.	Q.P.	AV.
1	0.15391	9.95	37.03	19.13	46.98	29.08	65.79	55.79	-18.81	-26.71
2	0.18516	9.96	29.79	13.83	39.75	23.79	64.25	54.25	-24.50	-30.46
3	0.26328	9.96	19.64	8.85	29.60	18.81	61.33	51.33	-31.73	-32.52
4	0.48984	9.97	25.86	19.27	35.83	29.24	56.17	46.17	-20.34	-16.93
5	7.12500	10.41	12.02	6.18	22.43	16.59	60.00	50.00	-37.57	-33.41
6	23.58203	11.26	24.99	22.35	36.25	33.61	60.00	50.00	-23.75	-16.39

Remarks:

1. Q.P. and AV. are abbreviations of quasi-peak and average individually.
2. The emission levels of other frequencies were very low against the limit.
3. Margin value = Emission level – Limit value
4. Correction factor = Insertion loss + Cable loss
5. Emission Level = Correction Factor + Reading Value

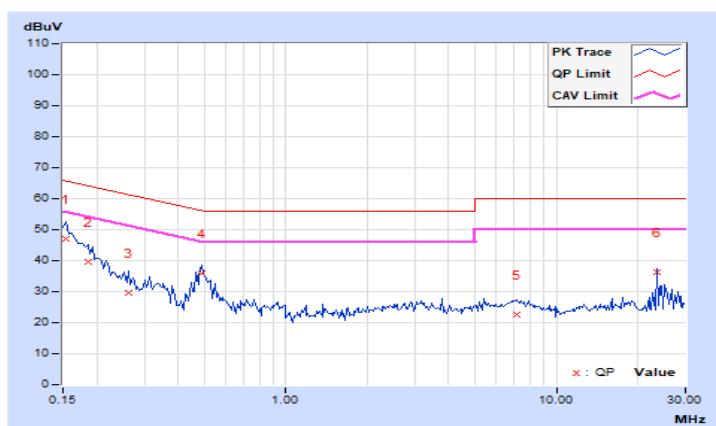

RF Mode	802.11a	Channel	CH 40 : 5200 MHz
Frequency Range	150 kHz ~ 30 MHz	Detector Function & Resolution Bandwidth	Quasi-Peak (QP) / Average (AV), 9 kHz
Input Power	120 Vac, 60 Hz	Environmental Conditions	24°C, 68% RH
Tested By	Sampson Chen		

Phase Of Power : Neutral (N)										
No	Frequency (MHz)	Correction Factor (dB)	Reading Value (dBuV)		Emission Level (dBuV)		Limit (dBuV)		Margin (dB)	
			Q.P.	AV.	Q.P.	AV.	Q.P.	AV.	Q.P.	AV.
1	0.15000	9.95	40.15	23.36	50.10	33.31	66.00	56.00	-15.90	-22.69
2	0.18906	9.96	32.01	16.22	41.97	26.18	64.08	54.08	-22.11	-27.90
3	0.25156	9.96	23.36	8.41	33.32	18.37	61.71	51.71	-28.39	-33.34
4	0.46250	9.96	19.55	14.00	29.51	23.96	56.65	46.65	-27.14	-22.69
5	2.26563	10.08	14.98	8.80	25.06	18.88	56.00	46.00	-30.94	-27.12
6	19.40625	10.95	18.19	12.17	29.14	23.12	60.00	50.00	-30.86	-26.88

Remarks:

1. Q.P. and AV. are abbreviations of quasi-peak and average individually.
2. The emission levels of other frequencies were very low against the limit.
3. Margin value = Emission level – Limit value
4. Correction factor = Insertion loss + Cable loss
5. Emission Level = Correction Factor + Reading Value

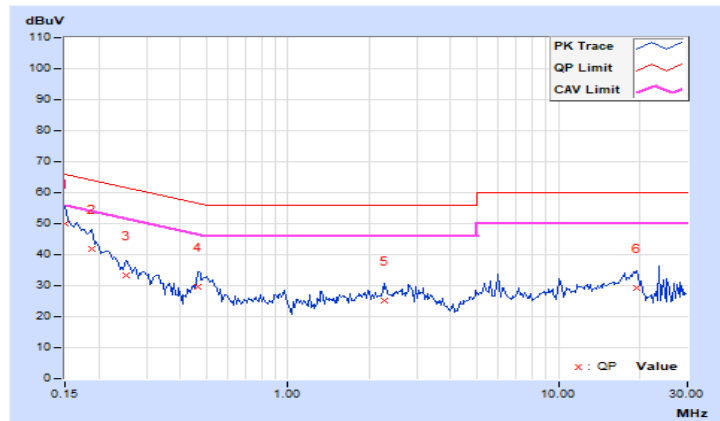

7.7 Unwanted Emissions below 1 GHz

RF Mode	802.11a	Channel	CH 40 : 5200 MHz
Frequency Range	30 MHz ~ 1 GHz	Detector Function & Bandwidth	(QP) RB = 120kHz
Input Power	120 Vac, 60 Hz	Environmental Conditions	24°C, 68% RH
Tested By	Nick		

Antenna Polarity & Test Distance : Horizontal at 3 m								
No	Frequency (MHz)	Emission Level (dBuV/m)	Limit (dBuV/m)	Margin (dB)	Antenna Height (m)	Table Angle (Degree)	Raw Value (dBuV)	Correction Factor (dB/m)
1	41.25	25.2 QP	40.0	-14.8	3.00 H	57	37.9	-12.7
2	89.66	31.3 QP	43.5	-12.2	2.00 H	302	49.7	-18.4
3	204.75	34.7 QP	43.5	-8.8	2.00 H	272	50.9	-16.2
4	288.28	32.5 QP	46.0	-13.5	1.00 H	238	44.9	-12.4
5	402.55	30.7 QP	46.0	-15.3	1.00 H	178	40.4	-9.7
6	499.99	39.4 QP	46.0	-6.6	1.50 H	182	46.8	-7.4

Remarks:

1. Emission Level(dBuV/m) = Raw Value(dBuV) + Correction Factor(dB/m)
2. Correction Factor(dB/m) = Antenna Factor(dB/m) + Cable Factor(dB) – Pre-Amplifier Factor(dB)
3. Margin value = Emission Level – Limit value
4. The other emission levels were very low against the limit of frequency range 30 MHz ~ 1 GHz.
5. The emission levels were very low against the limit of frequency range 9 kHz ~ 30 MHz: the amplitude of spurious emissions attenuated more than 20 dB below the permissible value to be report.

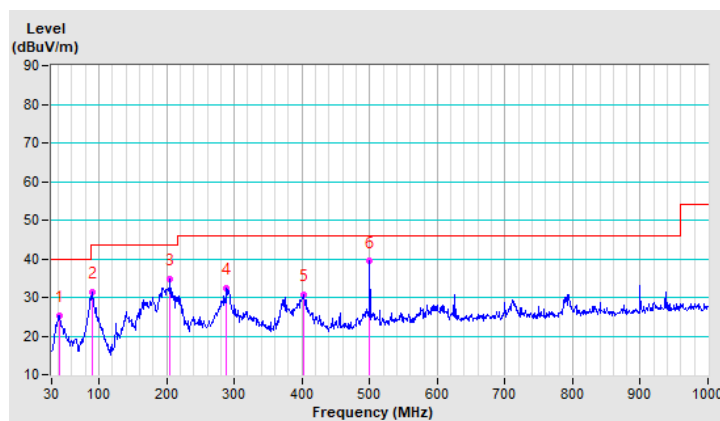

RF Mode	802.11a	Channel	CH 40 : 5200 MHz
Frequency Range	30 MHz ~ 1 GHz	Detector Function & Bandwidth	(QP) RB = 120kHz
Input Power	120 Vac, 60 Hz	Environmental Conditions	24°C, 68% RH
Tested By	Nick		

Antenna Polarity & Test Distance : Vertical at 3 m								
No	Frequency (MHz)	Emission Level (dBuV/m)	Limit (dBuV/m)	Margin (dB)	Antenna Height (m)	Table Angle (Degree)	Raw Value (dBuV)	Correction Factor (dB/m)
1	40.72	34.7 QP	40.0	-5.3	2.00 V	134	47.5	-12.8
2	92.23	35.1 QP	43.5	-8.4	1.00 V	279	53.3	-18.2
3	202.38	39.6 QP	43.5	-3.9	1.00 V	328	55.7	-16.1
4	289.63	34.1 QP	46.0	-11.9	1.50 V	193	46.5	-12.4
5	499.99	42.9 QP	46.0	-3.1	1.00 V	220	50.3	-7.4
6	625.03	35.5 QP	46.0	-10.5	1.00 V	225	40.3	-4.8

Remarks:

1. Emission Level(dBuV/m) = Raw Value(dBuV) + Correction Factor(dB/m)
2. Correction Factor(dB/m) = Antenna Factor(dB/m) + Cable Factor(dB) – Pre-Amplifier Factor(dB)
3. Margin value = Emission Level – Limit value
4. The other emission levels were very low against the limit of frequency range 30 MHz ~ 1 GHz.
5. The emission levels were very low against the limit of frequency range 9 kHz ~ 30 MHz: the amplitude of spurious emissions attenuated more than 20 dB below the permissible value to be report.

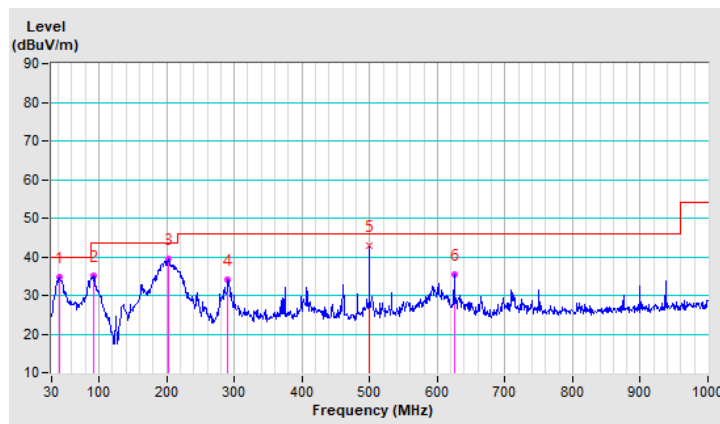

7.8 Unwanted Emissions above 1 GHz

RF Mode	802.11a	Channel	CH 36 : 5180 MHz
Frequency Range	1 GHz ~ 40 GHz	Detector Function & Bandwidth	(PK) RB = 1 MHz, VB = 3 MHz (AV) RB = 1 MHz, VB = 10 Hz
Input Power	120 Vac, 60 Hz	Environmental Conditions	22°C, 71% RH
Tested By	Sampson Chen		

Antenna Polarity & Test Distance : Horizontal at 3 m								
No	Frequency (MHz)	Emission Level (dBuV/m)	Limit (dBuV/m)	Margin (dB)	Antenna Height (m)	Table Angle (Degree)	Raw Value (dBuV)	Correction Factor (dB/m)
1	5143.54	66.4 PK	74.0	-7.6	1.62 H	312	61.2	5.2
2	5143.54	51.7 AV	54.0	-2.3	1.62 H	312	46.5	5.2
3	*5180.00	117.6 PK			1.62 H	312	112.5	5.1
4	*5180.00	108.2 AV			1.62 H	312	103.1	5.1
5	#10360.00	46.6 PK	68.2	-21.6	1.58 H	18	30.6	16.0
6	15540.00	65.7 PK	74.0	-8.3	1.50 H	360	48.3	17.4
7	15540.00	52.9 AV	54.0	-1.1	1.50 H	360	35.5	17.4

Remarks:

1. Emission Level(dBuV/m) = Raw Value(dBuV) + Correction Factor(dB/m)
2. Correction Factor(dB/m) = Antenna Factor(dB/m) + Cable Factor(dB) – Pre-Amplifier Factor(dB)
3. Margin value = Emission Level – Limit value
4. The other emission levels were very low against the limit.
5. " * " : Fundamental frequency, the limit was restricted at the RF Output Power.
6. " # " : The radiated frequency is out of the restricted band.

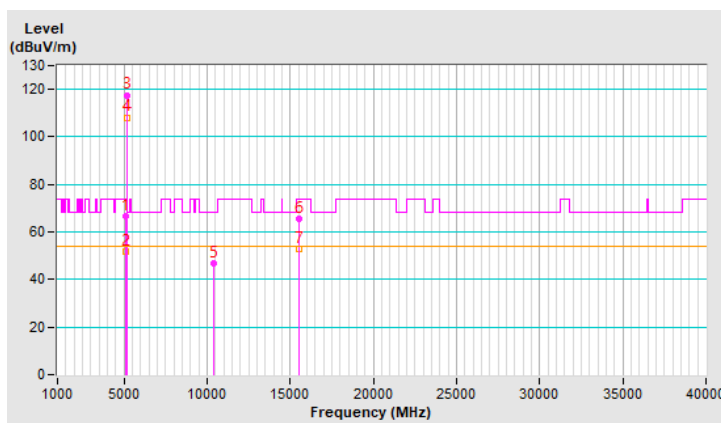

RF Mode	802.11a	Channel	CH 36 : 5180 MHz
Frequency Range	1 GHz ~ 40 GHz	Detector Function & Bandwidth	(PK) RB = 1 MHz, VB = 3 MHz (AV) RB = 1 MHz, VB = 10 Hz
Input Power	120 Vac, 60 Hz	Environmental Conditions	22°C, 71% RH
Tested By	Sampson Chen		

Antenna Polarity & Test Distance : Vertical at 3 m								
No	Frequency (MHz)	Emission Level (dBuV/m)	Limit (dBuV/m)	Margin (dB)	Antenna Height (m)	Table Angle (Degree)	Raw Value (dBuV)	Correction Factor (dB/m)
1	5147.11	64.0 PK	74.0	-10.0	2.11 V	341	58.8	5.2
2	5147.11	53.3 AV	54.0	-0.7	2.11 V	341	48.1	5.2
3	*5180.00	122.2 PK			2.11 V	341	117.1	5.1
4	*5180.00	113.1 AV			2.11 V	341	108.0	5.1
5	#10360.00	46.8 PK	68.2	-21.4	1.47 V	261	30.8	16.0
6	15540.00	64.6 PK	74.0	-9.4	1.49 V	318	47.2	17.4
7	15540.00	50.9 AV	54.0	-3.1	1.49 V	318	33.5	17.4

Remarks:

1. Emission Level(dBuV/m) = Raw Value(dBuV) + Correction Factor(dB/m)
2. Correction Factor(dB/m) = Antenna Factor(dB/m) + Cable Factor(dB) – Pre-Amplifier Factor(dB)
3. Margin value = Emission Level – Limit value
4. The other emission levels were very low against the limit.
5. " * " : Fundamental frequency, the limit was restricted at the RF Output Power.
6. " # " : The radiated frequency is out of the restricted band.

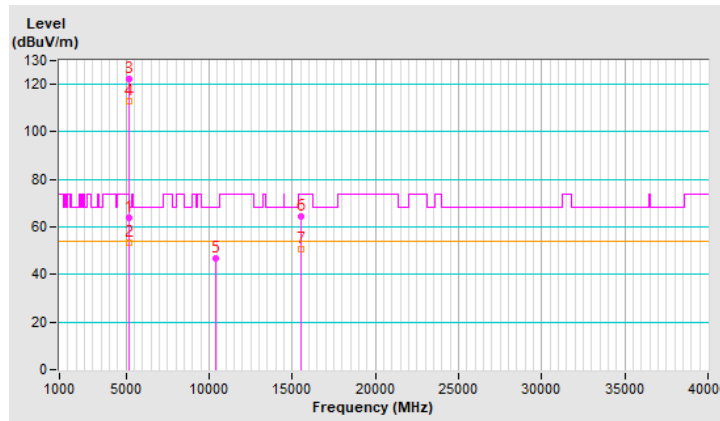

RF Mode	802.11a	Channel	CH 40 : 5200 MHz
Frequency Range	1 GHz ~ 40 GHz	Detector Function & Bandwidth	(PK) RB = 1 MHz, VB = 3 MHz (AV) RB = 1 MHz, VB = 10 Hz
Input Power	120 Vac, 60 Hz	Environmental Conditions	22°C, 71% RH
Tested By	Sampson Chen		

Antenna Polarity & Test Distance : Horizontal at 3 m								
No	Frequency (MHz)	Emission Level (dBuV/m)	Limit (dBuV/m)	Margin (dB)	Antenna Height (m)	Table Angle (Degree)	Raw Value (dBuV)	Correction Factor (dB/m)
1	5150.00	67.8 PK	74.0	-6.2	2.67 H	273	62.6	5.2
2	5150.00	51.8 AV	54.0	-2.2	2.67 H	273	46.6	5.2
3	*5200.00	119.5 PK			2.67 H	273	114.4	5.1
4	*5200.00	110.2 AV			2.67 H	273	105.1	5.1
5	5365.00	57.6 PK	74.0	-16.4	2.67 H	273	52.6	5.0
6	5365.00	46.1 AV	54.0	-7.9	2.67 H	273	41.1	5.0
7	#10400.00	45.8 PK	68.2	-22.4	1.52 H	5	29.7	16.1
8	15600.00	66.2 PK	74.0	-7.8	1.51 H	353	48.9	17.3
9	15600.00	53.3 AV	54.0	-0.7	1.51 H	353	36.0	17.3

Remarks:

1. Emission Level(dBuV/m) = Raw Value(dBuV) + Correction Factor(dB/m)
2. Correction Factor(dB/m) = Antenna Factor(dB/m) + Cable Factor(dB) – Pre-Amplifier Factor(dB)
3. Margin value = Emission Level – Limit value
4. The other emission levels were very low against the limit.
5. " * " : Fundamental frequency, the limit was restricted at the RF Output Power.
6. " # " : The radiated frequency is out of the restricted band.

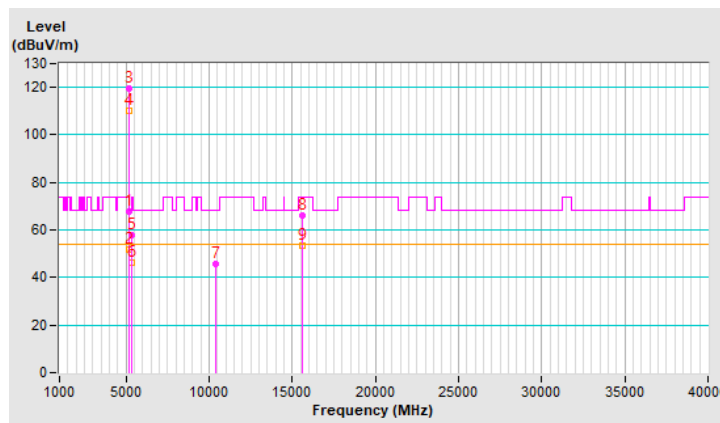

RF Mode	802.11a	Channel	CH 40 : 5200 MHz
Frequency Range	1 GHz ~ 40 GHz	Detector Function & Bandwidth	(PK) RB = 1 MHz, VB = 3 MHz (AV) RB = 1 MHz, VB = 10 Hz
Input Power	120 Vac, 60 Hz	Environmental Conditions	22°C, 71% RH
Tested By	Sampson Chen		

Antenna Polarity & Test Distance : Vertical at 3 m								
No	Frequency (MHz)	Emission Level (dBuV/m)	Limit (dBuV/m)	Margin (dB)	Antenna Height (m)	Table Angle (Degree)	Raw Value (dBuV)	Correction Factor (dB/m)
1	5146.30	67.2 PK	74.0	-6.8	2.19 V	340	62.0	5.2
2	5146.30	51.1 AV	54.0	-2.9	2.19 V	340	45.9	5.2
3	*5200.00	121.9 PK			2.19 V	340	116.8	5.1
4	*5200.00	112.8 AV			2.19 V	340	107.7	5.1
5	5355.29	58.8 PK	74.0	-15.2	2.19 V	340	53.8	5.0
6	5355.29	47.5 AV	54.0	-6.5	2.19 V	340	42.5	5.0
7	5393.21	56.9 PK	74.0	-17.1	2.19 V	340	52.0	4.9
8	5393.21	48.2 AV	54.0	-5.8	2.19 V	340	43.3	4.9
9	#10400.00	46.8 PK	68.2	-21.4	1.42 V	272	30.7	16.1
10	15600.00	64.0 PK	74.0	-10.0	1.53 V	321	46.7	17.3
11	15600.00	50.5 AV	54.0	-3.5	1.53 V	321	33.2	17.3

Remarks:

1. Emission Level(dBuV/m) = Raw Value(dBuV) + Correction Factor(dB/m)
2. Correction Factor(dB/m) = Antenna Factor(dB/m) + Cable Factor(dB) – Pre-Amplifier Factor(dB)
3. Margin value = Emission Level – Limit value
4. The other emission levels were very low against the limit.
5. " * ": Fundamental frequency, the limit was restricted at the RF Output Power.
6. " # ": The radiated frequency is out of the restricted band.

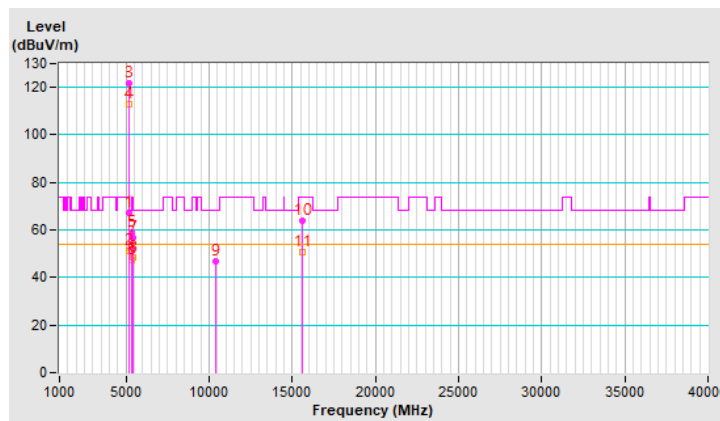

RF Mode	802.11a	Channel	CH 48 : 5240 MHz
Frequency Range	1 GHz ~ 40 GHz	Detector Function & Bandwidth	(PK) RB = 1 MHz, VB = 3 MHz (AV) RB = 1 MHz, VB = 10 Hz
Input Power	120 Vac, 60 Hz	Environmental Conditions	22°C, 71% RH
Tested By	Sampson Chen		

Antenna Polarity & Test Distance : Horizontal at 3 m

No	Frequency (MHz)	Emission Level (dBuV/m)	Limit (dBuV/m)	Margin (dB)	Antenna Height (m)	Table Angle (Degree)	Raw Value (dBuV)	Correction Factor (dB/m)
1	*5240.00	120.1 PK			3.24 H	282	115.2	4.9
2	*5240.00	110.7 AV			3.24 H	282	105.8	4.9
3	5355.00	57.6 PK	74.0	-16.4	3.24 H	282	52.6	5.0
4	5355.00	45.5 AV	54.0	-8.5	3.24 H	282	40.5	5.0
5	#10480.00	46.1 PK	68.2	-22.1	1.46 H	15	29.8	16.3
6	15720.00	66.2 PK	74.0	-7.8	2.51 H	360	49.4	16.8
7	15720.00	53.5 AV	54.0	-0.5	2.51 H	360	36.7	16.8

Remarks:

1. Emission Level(dBuV/m) = Raw Value(dBuV) + Correction Factor(dB/m)
2. Correction Factor(dB/m) = Antenna Factor(dB/m) + Cable Factor(dB) – Pre-Amplifier Factor(dB)
3. Margin value = Emission Level – Limit value
4. The other emission levels were very low against the limit.
5. " * " : Fundamental frequency, the limit was restricted at the RF Output Power.
6. " # " : The radiated frequency is out of the restricted band.

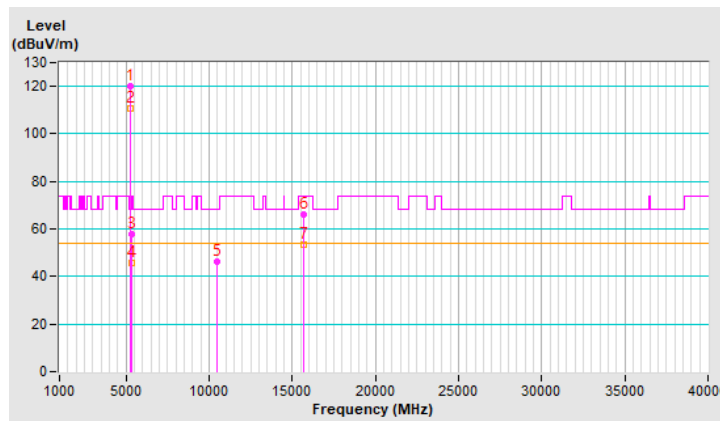

RF Mode	802.11a	Channel	CH 48 : 5240 MHz
Frequency Range	1 GHz ~ 40 GHz	Detector Function & Bandwidth	(PK) RB = 1 MHz, VB = 3 MHz (AV) RB = 1 MHz, VB = 10 Hz
Input Power	120 Vac, 60 Hz	Environmental Conditions	22°C, 71% RH
Tested By	Sampson Chen		

Antenna Polarity & Test Distance : Vertical at 3 m

No	Frequency (MHz)	Emission Level (dBuV/m)	Limit (dBuV/m)	Margin (dB)	Antenna Height (m)	Table Angle (Degree)	Raw Value (dBuV)	Correction Factor (dB/m)
1	*5240.00	120.4 PK			2.83 V	360	115.5	4.9
2	*5240.00	111.4 AV			2.83 V	360	106.5	4.9
3	5350.00	57.6 PK	74.0	-16.4	2.83 V	360	52.6	5.0
4	5350.00	47.3 AV	54.0	-6.7	2.83 V	360	42.3	5.0
5	#10480.00	46.5 PK	68.2	-21.7	1.42 V	248	30.2	16.3
6	15720.00	64.4 PK	74.0	-9.6	1.43 V	323	47.6	16.8
7	15720.00	50.4 AV	54.0	-3.6	1.43 V	323	33.6	16.8

Remarks:

1. Emission Level(dBuV/m) = Raw Value(dBuV) + Correction Factor(dB/m)
2. Correction Factor(dB/m) = Antenna Factor(dB/m) + Cable Factor(dB) – Pre-Amplifier Factor(dB)
3. Margin value = Emission Level – Limit value
4. The other emission levels were very low against the limit.
5. " * " : Fundamental frequency, the limit was restricted at the RF Output Power.
6. " # " : The radiated frequency is out of the restricted band.

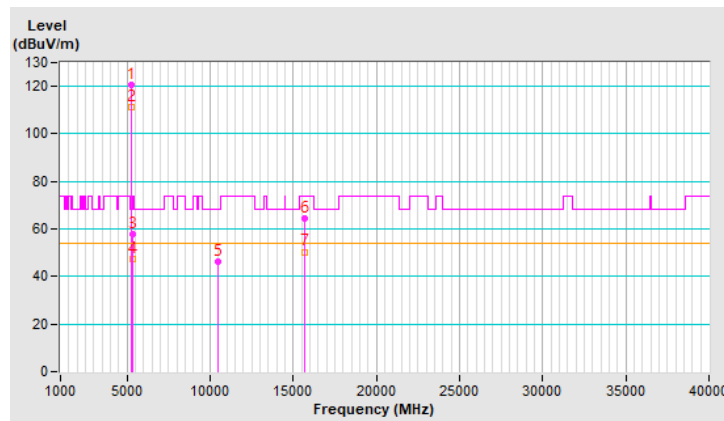

RF Mode	802.11a	Channel	CH 149 : 5745 MHz
Frequency Range	1 GHz ~ 40 GHz	Detector Function & Bandwidth	(PK) RB = 1 MHz, VB = 3 MHz (AV) RB = 1 MHz, VB = 10 Hz
Input Power	120 Vac, 60 Hz	Environmental Conditions	22°C, 71% RH
Tested By	Sampson Chen		

Antenna Polarity & Test Distance : Horizontal at 3 m								
No	Frequency (MHz)	Emission Level (dBuV/m)	Limit (dBuV/m)	Margin (dB)	Antenna Height (m)	Table Angle (Degree)	Raw Value (dBuV)	Correction Factor (dB/m)
1	#5650.00	55.7 PK	68.2	-12.5	1.50 H	276	50.0	5.7
2	*5745.00	117.5 PK			1.50 H	276	111.7	5.8
3	*5745.00	108.2 AV			1.50 H	276	102.4	5.8
4	#5923.97	52.7 PK	68.2	-15.5	1.50 H	276	46.3	6.4
5	11490.00	57.3 PK	74.0	-16.7	2.74 H	360	40.0	17.3
6	11490.00	46.4 AV	54.0	-7.6	2.74 H	360	29.1	17.3
7	#17235.00	65.5 PK	68.2	-2.7	1.53 H	360	44.9	20.6

Remarks:

1. Emission Level(dBuV/m) = Raw Value(dBuV) + Correction Factor(dB/m)
2. Correction Factor(dB/m) = Antenna Factor(dB/m) + Cable Factor(dB) – Pre-Amplifier Factor(dB)
3. Margin value = Emission Level – Limit value
4. The other emission levels were very low against the limit.
5. " * " : Fundamental frequency, the limit was restricted at the RF Output Power.
6. " # " : The radiated frequency is out of the restricted band.

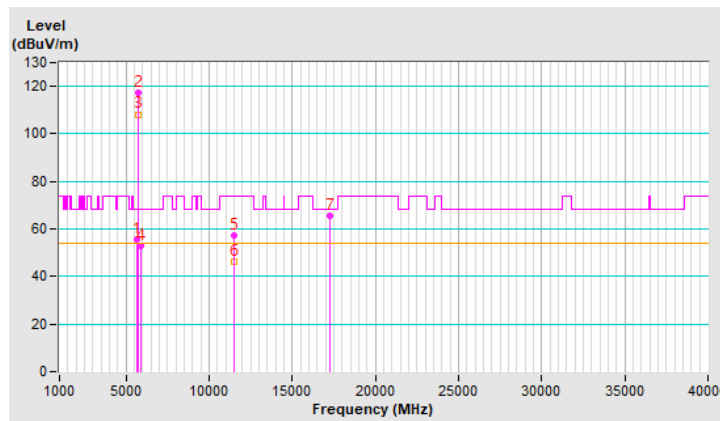

RF Mode	802.11a	Channel	CH 149 : 5745 MHz
Frequency Range	1 GHz ~ 40 GHz	Detector Function & Bandwidth	(PK) RB = 1 MHz, VB = 3 MHz (AV) RB = 1 MHz, VB = 10 Hz
Input Power	120 Vac, 60 Hz	Environmental Conditions	22°C, 71% RH
Tested By	Sampson Chen		

Antenna Polarity & Test Distance : Vertical at 3 m

No	Frequency (MHz)	Emission Level (dBuV/m)	Limit (dBuV/m)	Margin (dB)	Antenna Height (m)	Table Angle (Degree)	Raw Value (dBuV)	Correction Factor (dB/m)
1	#5650.00	57.6 PK	68.2	-10.6	1.55 V	221	51.9	5.7
2	*5745.00	119.7 PK			1.55 V	221	113.9	5.8
3	*5745.00	109.5 AV			1.55 V	221	103.7	5.8
4	#5941.35	53.8 PK	68.2	-14.4	1.55 V	221	47.3	6.5
5	11490.00	58.3 PK	74.0	-15.7	2.63 V	274	41.0	17.3
6	11490.00	45.9 AV	54.0	-8.1	2.63 V	274	28.6	17.3
7	#17235.00	58.3 PK	68.2	-9.9	1.45 V	315	37.7	20.6

Remarks:

1. Emission Level(dBuV/m) = Raw Value(dBuV) + Correction Factor(dB/m)
2. Correction Factor(dB/m) = Antenna Factor(dB/m) + Cable Factor(dB) – Pre-Amplifier Factor(dB)
3. Margin value = Emission Level – Limit value
4. The other emission levels were very low against the limit.
5. " * " : Fundamental frequency, the limit was restricted at the RF Output Power.
6. " # " : The radiated frequency is out of the restricted band.

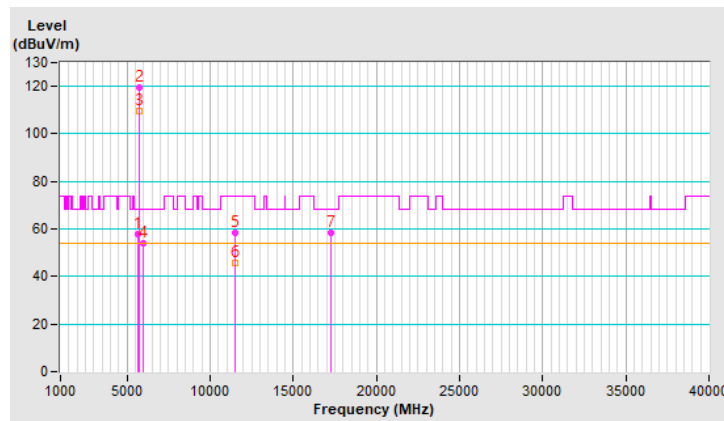

RF Mode	802.11a	Channel	CH 157 : 5785 MHz
Frequency Range	1 GHz ~ 40 GHz	Detector Function & Bandwidth	(PK) RB = 1 MHz, VB = 3 MHz (AV) RB = 1 MHz, VB = 10 Hz
Input Power	120 Vac, 60 Hz	Environmental Conditions	22°C, 71% RH
Tested By	Sampson Chen		

Antenna Polarity & Test Distance : Horizontal at 3 m

No	Frequency (MHz)	Emission Level (dBuV/m)	Limit (dBuV/m)	Margin (dB)	Antenna Height (m)	Table Angle (Degree)	Raw Value (dBuV)	Correction Factor (dB/m)
1	#5645.95	55.6 PK	68.2	-12.6	3.77 H	267	49.9	5.7
2	*5785.00	121.5 PK			3.77 H	267	115.6	5.9
3	*5785.00	112.0 AV			3.77 H	267	106.1	5.9
4	#5928.82	53.5 PK	68.2	-14.7	3.77 H	267	47.1	6.4
5	11570.00	57.9 PK	74.0	-16.1	2.78 H	360	40.8	17.1
6	11570.00	46.8 AV	54.0	-7.2	2.78 H	360	29.7	17.1
7	#17355.00	63.3 PK	68.2	-4.9	2.53 H	267	42.2	21.1

Remarks:

1. Emission Level(dBuV/m) = Raw Value(dBuV) + Correction Factor(dB/m)
2. Correction Factor(dB/m) = Antenna Factor(dB/m) + Cable Factor(dB) – Pre-Amplifier Factor(dB)
3. Margin value = Emission Level – Limit value
4. The other emission levels were very low against the limit.
5. " * " : Fundamental frequency, the limit was restricted at the RF Output Power.
6. " # " : The radiated frequency is out of the restricted band.

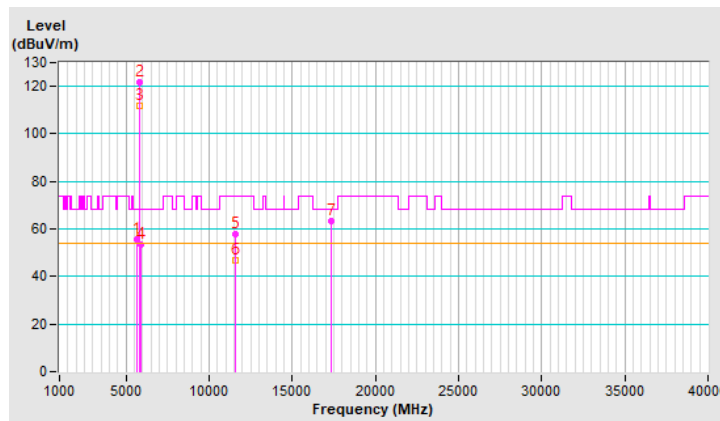

RF Mode	802.11a	Channel	CH 157 : 5785 MHz
Frequency Range	1 GHz ~ 40 GHz	Detector Function & Bandwidth	(PK) RB = 1 MHz, VB = 3 MHz (AV) RB = 1 MHz, VB = 10 Hz
Input Power	120 Vac, 60 Hz	Environmental Conditions	22°C, 71% RH
Tested By	Sampson Chen		

Antenna Polarity & Test Distance : Vertical at 3 m								
No	Frequency (MHz)	Emission Level (dBuV/m)	Limit (dBuV/m)	Margin (dB)	Antenna Height (m)	Table Angle (Degree)	Raw Value (dBuV)	Correction Factor (dB/m)
1	#5646.32	67.1 PK	68.2	-1.1	2.38 V	203	61.4	5.7
2	*5785.00	124.5 PK			2.38 V	203	118.6	5.9
3	*5785.00	115.1 AV			2.38 V	203	109.2	5.9
4	#5925.59	55.3 PK	68.2	-12.9	2.38 V	203	48.9	6.4
5	11570.00	57.3 PK	74.0	-16.7	2.60 V	254	40.2	17.1
6	11570.00	45.4 AV	54.0	-8.6	2.60 V	254	28.3	17.1
7	#17355.00	58.3 PK	68.2	-9.9	1.54 V	331	37.2	21.1

Remarks:

1. Emission Level(dBuV/m) = Raw Value(dBuV) + Correction Factor(dB/m)
2. Correction Factor(dB/m) = Antenna Factor(dB/m) + Cable Factor(dB) – Pre-Amplifier Factor(dB)
3. Margin value = Emission Level – Limit value
4. The other emission levels were very low against the limit.
5. " * " : Fundamental frequency, the limit was restricted at the RF Output Power.
6. " # " : The radiated frequency is out of the restricted band.

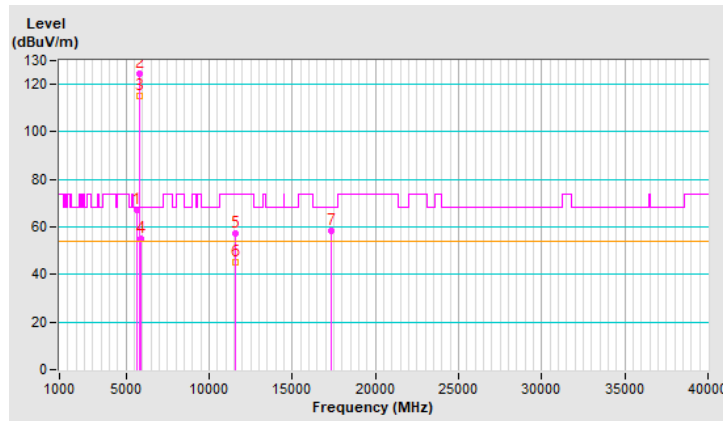

RF Mode	802.11a	Channel	CH 165 : 5825 MHz
Frequency Range	1 GHz ~ 40 GHz	Detector Function & Bandwidth	(PK) RB = 1 MHz, VB = 3 MHz (AV) RB = 1 MHz, VB = 10 Hz
Input Power	120 Vac, 60 Hz	Environmental Conditions	22°C, 71% RH
Tested By	Sampson Chen		

Antenna Polarity & Test Distance : Horizontal at 3 m								
No	Frequency (MHz)	Emission Level (dBuV/m)	Limit (dBuV/m)	Margin (dB)	Antenna Height (m)	Table Angle (Degree)	Raw Value (dBuV)	Correction Factor (dB/m)
1	#5649.73	55.4 PK	68.2	-12.8	3.70 H	263	49.7	5.7
2	*5825.00	121.9 PK			3.70 H	263	115.9	6.0
3	*5825.00	111.2 AV			3.70 H	263	105.2	6.0
4	#5930.08	52.3 PK	68.2	-15.9	3.70 H	263	45.9	6.4
5	11650.00	58.1 PK	74.0	-15.9	2.93 H	360	41.4	16.7
6	11650.00	48.4 AV	54.0	-5.6	2.93 H	360	31.7	16.7
7	#17475.00	65.4 PK	68.2	-2.8	1.56 H	256	42.9	22.5

Remarks:

1. Emission Level(dBuV/m) = Raw Value(dBuV) + Correction Factor(dB/m)
2. Correction Factor(dB/m) = Antenna Factor(dB/m) + Cable Factor(dB) – Pre-Amplifier Factor(dB)
3. Margin value = Emission Level – Limit value
4. The other emission levels were very low against the limit.
5. " * " : Fundamental frequency, the limit was restricted at the RF Output Power.
6. " # " : The radiated frequency is out of the restricted band.

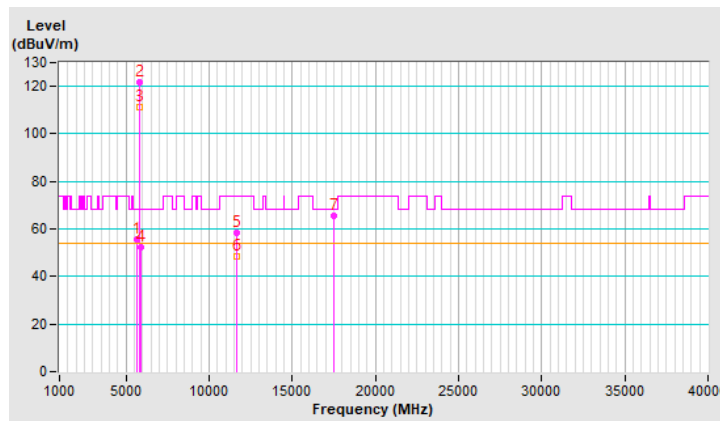

RF Mode	802.11a	Channel	CH 165 : 5825 MHz
Frequency Range	1 GHz ~ 40 GHz	Detector Function & Bandwidth	(PK) RB = 1 MHz, VB = 3 MHz (AV) RB = 1 MHz, VB = 10 Hz
Input Power	120 Vac, 60 Hz	Environmental Conditions	22°C, 71% RH
Tested By	Sampson Chen		

Antenna Polarity & Test Distance : Vertical at 3 m								
No	Frequency (MHz)	Emission Level (dBuV/m)	Limit (dBuV/m)	Margin (dB)	Antenna Height (m)	Table Angle (Degree)	Raw Value (dBuV)	Correction Factor (dB/m)
1	#5626.26	61.2 PK	68.2	-7.0	2.56 V	204	55.5	5.7
2	*5825.00	124.2 PK			2.56 V	204	118.2	6.0
3	*5825.00	114.1 AV			2.56 V	204	108.1	6.0
4	#5926.62	57.4 PK	68.2	-10.8	2.56 V	204	51.0	6.4
5	11650.00	58.0 PK	74.0	-16.0	2.63 V	269	41.3	16.7
6	11650.00	45.8 AV	54.0	-8.2	2.63 V	269	29.1	16.7
7	#17475.00	58.2 PK	68.2	-10.0	1.46 V	327	35.7	22.5

Remarks:

1. Emission Level(dBuV/m) = Raw Value(dBuV) + Correction Factor(dB/m)
2. Correction Factor(dB/m) = Antenna Factor(dB/m) + Cable Factor(dB) – Pre-Amplifier Factor(dB)
3. Margin value = Emission Level – Limit value
4. The other emission levels were very low against the limit.
5. " * " : Fundamental frequency, the limit was restricted at the RF Output Power.
6. " # " : The radiated frequency is out of the restricted band.

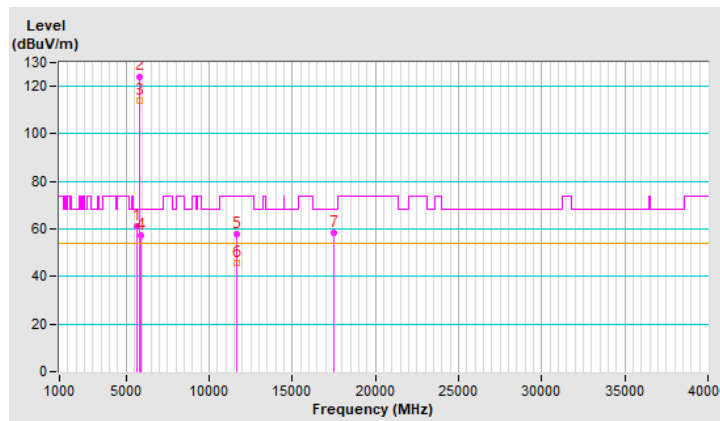

RF Mode	802.11ax (HE20)	Channel	CH 36 : 5180 MHz
Frequency Range	1 GHz ~ 40 GHz	Detector Function & Bandwidth	(PK) RB = 1 MHz, VB = 3 MHz (AV) RB = 1 MHz, VB = 10 Hz
Input Power	120 Vac, 60 Hz	Environmental Conditions	22°C, 71% RH
Tested By	Sampson Chen		

Antenna Polarity & Test Distance : Horizontal at 3 m								
No	Frequency (MHz)	Emission Level (dBuV/m)	Limit (dBuV/m)	Margin (dB)	Antenna Height (m)	Table Angle (Degree)	Raw Value (dBuV)	Correction Factor (dB/m)
1	5150.00	62.9 PK	74.0	-11.1	1.61 H	311	57.7	5.2
2	5150.00	50.4 AV	54.0	-3.6	1.61 H	311	45.2	5.2
3	*5180.00	116.2 PK			1.61 H	311	111.1	5.1
4	*5180.00	107.5 AV			1.61 H	311	102.4	5.1
5	#10360.00	46.1 PK	68.2	-22.1	1.52 H	10	30.1	16.0
6	15540.00	65.3 PK	74.0	-8.7	1.47 H	360	47.9	17.4
7	15540.00	52.5 AV	54.0	-1.5	1.47 H	360	35.1	17.4

Remarks:

1. Emission Level(dBuV/m) = Raw Value(dBuV) + Correction Factor(dB/m)
2. Correction Factor(dB/m) = Antenna Factor(dB/m) + Cable Factor(dB) – Pre-Amplifier Factor(dB)
3. Margin value = Emission Level – Limit value
4. The other emission levels were very low against the limit.
5. " * " : Fundamental frequency, the limit was restricted at the RF Output Power.
6. " # " : The radiated frequency is out of the restricted band.

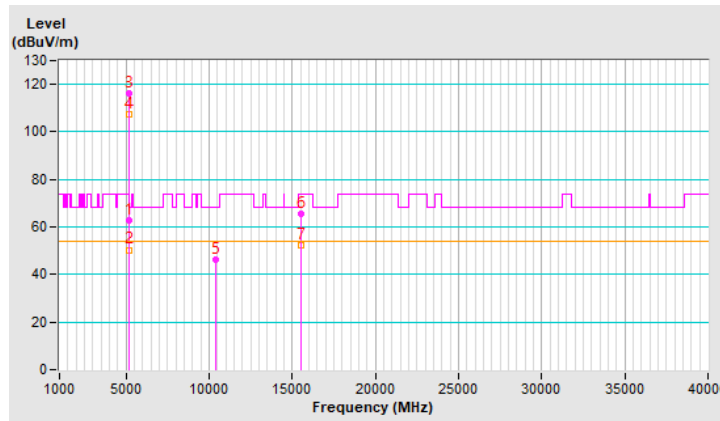

RF Mode	802.11ax (HE20)	Channel	CH 36 : 5180 MHz
Frequency Range	1 GHz ~ 40 GHz	Detector Function & Bandwidth	(PK) RB = 1 MHz, VB = 3 MHz (AV) RB = 1 MHz, VB = 10 Hz
Input Power	120 Vac, 60 Hz	Environmental Conditions	22°C, 71% RH
Tested By	Sampson Chen		

Antenna Polarity & Test Distance : Vertical at 3 m								
No	Frequency (MHz)	Emission Level (dBuV/m)	Limit (dBuV/m)	Margin (dB)	Antenna Height (m)	Table Angle (Degree)	Raw Value (dBuV)	Correction Factor (dB/m)
1	5150.00	64.8 PK	74.0	-9.2	2.00 V	341	59.6	5.2
2	5150.00	53.5 AV	54.0	-0.5	2.00 V	341	48.3	5.2
3	*5180.00	122.2 PK			2.00 V	341	117.1	5.1
4	*5180.00	111.1 AV			2.00 V	341	106.0	5.1
5	#10360.00	46.9 PK	68.2	-21.3	1.41 V	290	30.9	16.0
6	15540.00	60.2 PK	74.0	-13.8	2.58 V	335	42.8	17.4
7	15540.00	48.8 AV	54.0	-5.2	2.58 V	335	31.4	17.4

Remarks:

1. Emission Level(dBuV/m) = Raw Value(dBuV) + Correction Factor(dB/m)
2. Correction Factor(dB/m) = Antenna Factor(dB/m) + Cable Factor(dB) – Pre-Amplifier Factor(dB)
3. Margin value = Emission Level – Limit value
4. The other emission levels were very low against the limit.
5. " * " : Fundamental frequency, the limit was restricted at the RF Output Power.
6. " # " : The radiated frequency is out of the restricted band.

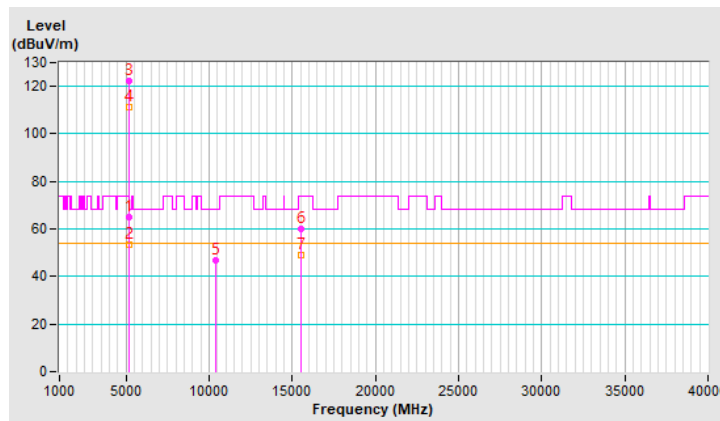

RF Mode	802.11ax (HE20)	Channel	CH 40 : 5200 MHz
Frequency Range	1 GHz ~ 40 GHz	Detector Function & Bandwidth	(PK) RB = 1 MHz, VB = 3 MHz (AV) RB = 1 MHz, VB = 10 Hz
Input Power	120 Vac, 60 Hz	Environmental Conditions	22°C, 71% RH
Tested By	Sampson Chen		

Antenna Polarity & Test Distance : Horizontal at 3 m

No	Frequency (MHz)	Emission Level (dBuV/m)	Limit (dBuV/m)	Margin (dB)	Antenna Height (m)	Table Angle (Degree)	Raw Value (dBuV)	Correction Factor (dB/m)
1	5150.00	62.4 PK	74.0	-11.6	1.67 H	311	57.2	5.2
2	5150.00	49.0 AV	54.0	-5.0	1.67 H	311	43.8	5.2
3	*5200.00	116.9 PK			1.67 H	311	111.8	5.1
4	*5200.00	107.1 AV			1.67 H	311	102.0	5.1
5	#10400.00	47.9 PK	68.2	-20.3	1.61 H	20	31.8	16.1
6	15600.00	65.6 PK	74.0	-8.4	1.53 H	359	48.3	17.3
7	15600.00	52.6 AV	54.0	-1.4	1.53 H	359	35.3	17.3

Remarks:

1. Emission Level(dBuV/m) = Raw Value(dBuV) + Correction Factor(dB/m)
2. Correction Factor(dB/m) = Antenna Factor(dB/m) + Cable Factor(dB) – Pre-Amplifier Factor(dB)
3. Margin value = Emission Level – Limit value
4. The other emission levels were very low against the limit.
5. " * " : Fundamental frequency, the limit was restricted at the RF Output Power.
6. " # " : The radiated frequency is out of the restricted band.

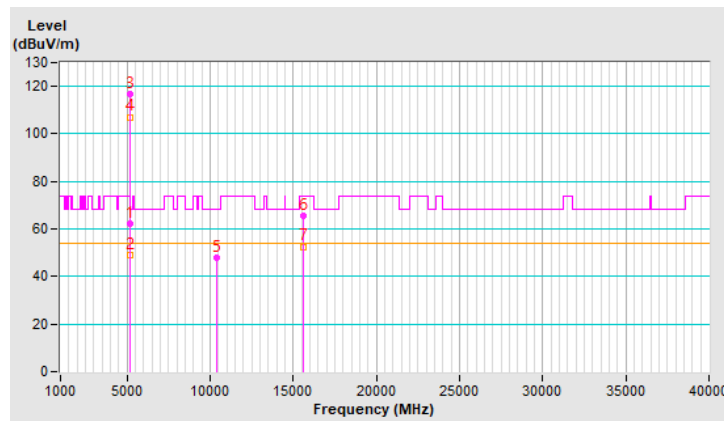

RF Mode	802.11ax (HE20)	Channel	CH 40 : 5200 MHz
Frequency Range	1 GHz ~ 40 GHz	Detector Function & Bandwidth	(PK) RB = 1 MHz, VB = 3 MHz (AV) RB = 1 MHz, VB = 10 Hz
Input Power	120 Vac, 60 Hz	Environmental Conditions	22°C, 71% RH
Tested By	Sampson Chen		

Antenna Polarity & Test Distance : Vertical at 3 m								
No	Frequency (MHz)	Emission Level (dBuV/m)	Limit (dBuV/m)	Margin (dB)	Antenna Height (m)	Table Angle (Degree)	Raw Value (dBuV)	Correction Factor (dB/m)
1	5150.00	65.1 PK	74.0	-8.9	1.98 V	326	59.9	5.2
2	5150.00	53.4 AV	54.0	-0.6	1.98 V	326	48.2	5.2
3	*5200.00	121.2 PK			1.98 V	326	116.1	5.1
4	*5200.00	112.0 AV			1.98 V	326	106.9	5.1
5	#10400.00	47.4 PK	68.2	-20.8	1.50 V	262	31.3	16.1
6	15600.00	60.0 PK	74.0	-14.0	2.56 V	315	42.7	17.3
7	15600.00	48.8 AV	54.0	-5.2	2.56 V	315	31.5	17.3

Remarks:

1. Emission Level(dBuV/m) = Raw Value(dBuV) + Correction Factor(dB/m)
2. Correction Factor(dB/m) = Antenna Factor(dB/m) + Cable Factor(dB) – Pre-Amplifier Factor(dB)
3. Margin value = Emission Level – Limit value
4. The other emission levels were very low against the limit.
5. " * " : Fundamental frequency, the limit was restricted at the RF Output Power.
6. " # " : The radiated frequency is out of the restricted band.

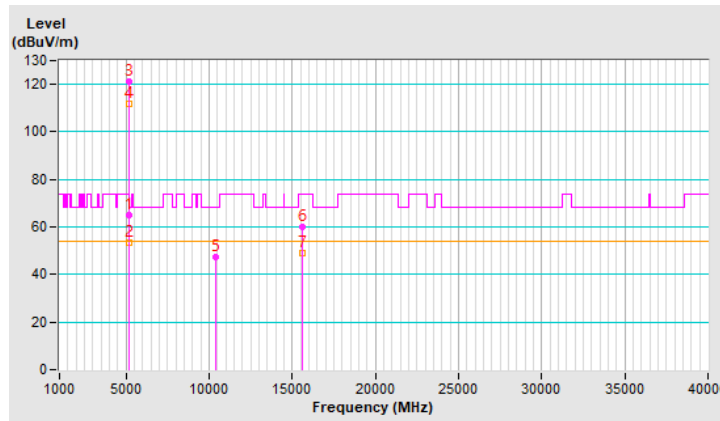

RF Mode	802.11ax (HE20)	Channel	CH 48 : 5240 MHz
Frequency Range	1 GHz ~ 40 GHz	Detector Function & Bandwidth	(PK) RB = 1 MHz, VB = 3 MHz (AV) RB = 1 MHz, VB = 10 Hz
Input Power	120 Vac, 60 Hz	Environmental Conditions	22°C, 71% RH
Tested By	Sampson Chen		

Antenna Polarity & Test Distance : Horizontal at 3 m								
No	Frequency (MHz)	Emission Level (dBuV/m)	Limit (dBuV/m)	Margin (dB)	Antenna Height (m)	Table Angle (Degree)	Raw Value (dBuV)	Correction Factor (dB/m)
1	*5240.00	117.0 PK			1.49 H	315	112.1	4.9
2	*5240.00	107.8 AV			1.49 H	315	102.9	4.9
3	5353.08	53.0 PK	74.0	-21.0	1.49 H	315	48.0	5.0
4	5353.08	42.7 AV	54.0	-11.3	1.49 H	315	37.7	5.0
5	#10480.00	47.1 PK	68.2	-21.1	2.18 H	215	30.8	16.3
6	15720.00	68.0 PK	74.0	-6.0	1.35 H	360	51.2	16.8
7	15720.00	53.5 AV	54.0	-0.5	1.35 H	360	36.7	16.8

Remarks:

1. Emission Level(dBuV/m) = Raw Value(dBuV) + Correction Factor(dB/m)
2. Correction Factor(dB/m) = Antenna Factor(dB/m) + Cable Factor(dB) – Pre-Amplifier Factor(dB)
3. Margin value = Emission Level – Limit value
4. The other emission levels were very low against the limit.
5. " * " : Fundamental frequency, the limit was restricted at the RF Output Power.
6. " # " : The radiated frequency is out of the restricted band.

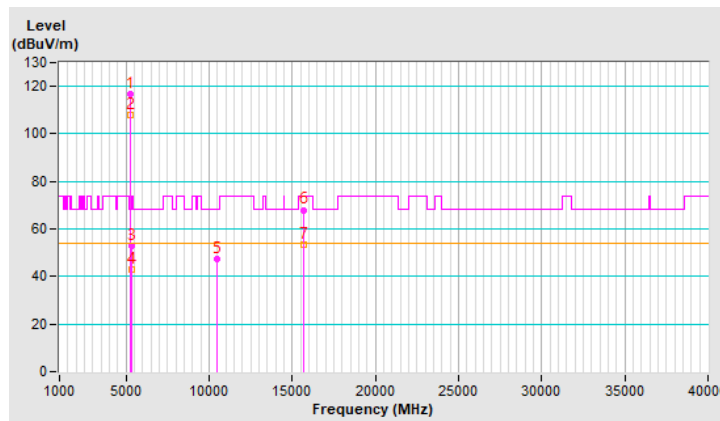

RF Mode	802.11ax (HE20)	Channel	CH 48 : 5240 MHz
Frequency Range	1 GHz ~ 40 GHz	Detector Function & Bandwidth	(PK) RB = 1 MHz, VB = 3 MHz (AV) RB = 1 MHz, VB = 10 Hz
Input Power	120 Vac, 60 Hz	Environmental Conditions	22°C, 71% RH
Tested By	Sampson Chen		

Antenna Polarity & Test Distance : Vertical at 3 m

No	Frequency (MHz)	Emission Level (dBuV/m)	Limit (dBuV/m)	Margin (dB)	Antenna Height (m)	Table Angle (Degree)	Raw Value (dBuV)	Correction Factor (dB/m)
1	*5240.00	121.9 PK			1.98 V	336	117.0	4.9
2	*5240.00	110.8 AV			1.98 V	336	105.9	4.9
3	5350.00	58.2 PK	74.0	-15.8	1.98 V	336	53.2	5.0
4	5350.00	47.8 AV	54.0	-6.2	1.98 V	336	42.8	5.0
5	#10480.00	46.9 PK	68.2	-21.3	1.47 V	272	30.6	16.3
6	15720.00	60.3 PK	74.0	-13.7	2.56 V	331	43.5	16.8
7	15720.00	48.8 AV	54.0	-5.2	2.56 V	331	32.0	16.8

Remarks:

1. Emission Level(dBuV/m) = Raw Value(dBuV) + Correction Factor(dB/m)
2. Correction Factor(dB/m) = Antenna Factor(dB/m) + Cable Factor(dB) – Pre-Amplifier Factor(dB)
3. Margin value = Emission Level – Limit value
4. The other emission levels were very low against the limit.
5. " * " : Fundamental frequency, the limit was restricted at the RF Output Power.
6. " # " : The radiated frequency is out of the restricted band.

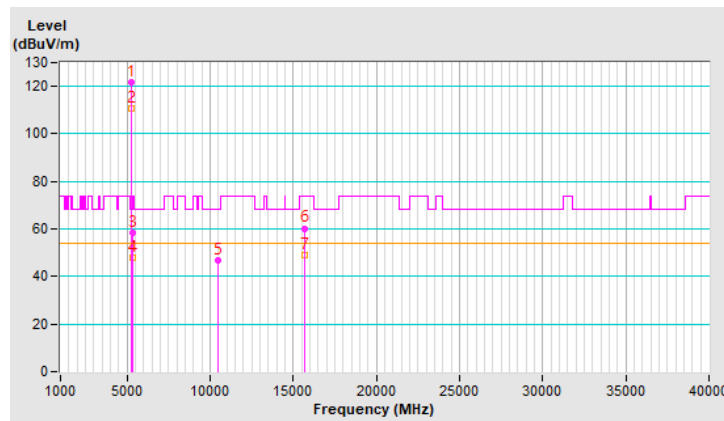

RF Mode	802.11ax (HE20)	Channel	CH 149 : 5745 MHz
Frequency Range	1 GHz ~ 40 GHz	Detector Function & Bandwidth	(PK) RB = 1 MHz, VB = 3 MHz (AV) RB = 1 MHz, VB = 10 Hz
Input Power	120 Vac, 60 Hz	Environmental Conditions	22°C, 71% RH
Tested By	Sampson Chen		

Antenna Polarity & Test Distance : Horizontal at 3 m

No	Frequency (MHz)	Emission Level (dBuV/m)	Limit (dBuV/m)	Margin (dB)	Antenna Height (m)	Table Angle (Degree)	Raw Value (dBuV)	Correction Factor (dB/m)
1	#5648.28	56.7 PK	68.2	-11.5	1.50 H	278	51.0	5.7
2	*5745.00	118.1 PK			1.50 H	278	112.3	5.8
3	*5745.00	107.3 AV			1.50 H	278	101.5	5.8
4	#5929.50	51.9 PK	68.2	-16.3	1.50 H	278	45.5	6.4
5	11490.00	58.3 PK	74.0	-15.7	2.93 H	360	41.0	17.3
6	11490.00	48.7 AV	54.0	-5.3	2.93 H	360	31.4	17.3
7	#17235.00	65.7 PK	68.2	-2.5	1.46 H	348	45.1	20.6

Remarks:

1. Emission Level(dBuV/m) = Raw Value(dBuV) + Correction Factor(dB/m)
2. Correction Factor(dB/m) = Antenna Factor(dB/m) + Cable Factor(dB) – Pre-Amplifier Factor(dB)
3. Margin value = Emission Level – Limit value
4. The other emission levels were very low against the limit.
5. " * " : Fundamental frequency, the limit was restricted at the RF Output Power.
6. " # " : The radiated frequency is out of the restricted band.

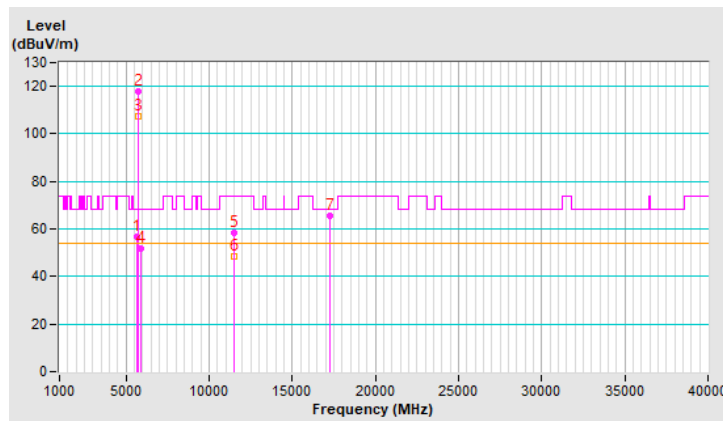

RF Mode	802.11ax (HE20)	Channel	CH 149 : 5745 MHz
Frequency Range	1 GHz ~ 40 GHz	Detector Function & Bandwidth	(PK) RB = 1 MHz, VB = 3 MHz (AV) RB = 1 MHz, VB = 10 Hz
Input Power	120 Vac, 60 Hz	Environmental Conditions	22°C, 71% RH
Tested By	Sampson Chen		

Antenna Polarity & Test Distance : Vertical at 3 m

No	Frequency (MHz)	Emission Level (dBuV/m)	Limit (dBuV/m)	Margin (dB)	Antenna Height (m)	Table Angle (Degree)	Raw Value (dBuV)	Correction Factor (dB/m)
1	#5649.37	59.3 PK	68.2	-8.9	2.43 V	204	53.6	5.7
2	*5745.00	124.2 PK			2.43 V	204	118.4	5.8
3	*5745.00	112.6 AV			2.43 V	204	106.8	5.8
4	#5927.04	53.0 PK	68.2	-15.2	2.43 V	204	46.6	6.4
5	11490.00	58.1 PK	74.0	-15.9	2.68 V	262	40.8	17.3
6	11490.00	46.2 AV	54.0	-7.8	2.68 V	262	28.9	17.3
7	#17235.00	58.6 PK	68.2	-9.6	1.43 V	307	38.0	20.6

Remarks:

1. Emission Level(dBuV/m) = Raw Value(dBuV) + Correction Factor(dB/m)
2. Correction Factor(dB/m) = Antenna Factor(dB/m) + Cable Factor(dB) – Pre-Amplifier Factor(dB)
3. Margin value = Emission Level – Limit value
4. The other emission levels were very low against the limit.
5. " * " : Fundamental frequency, the limit was restricted at the RF Output Power.
6. " # " : The radiated frequency is out of the restricted band.

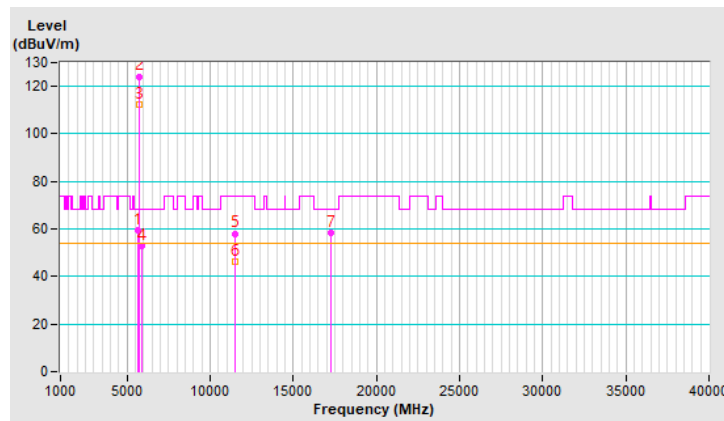

RF Mode	802.11ax (HE20)	Channel	CH 157 : 5785 MHz
Frequency Range	1 GHz ~ 40 GHz	Detector Function & Bandwidth	(PK) RB = 1 MHz, VB = 3 MHz (AV) RB = 1 MHz, VB = 10 Hz
Input Power	120 Vac, 60 Hz	Environmental Conditions	22°C, 71% RH
Tested By	Sampson Chen		

Antenna Polarity & Test Distance : Horizontal at 3 m

No	Frequency (MHz)	Emission Level (dBuV/m)	Limit (dBuV/m)	Margin (dB)	Antenna Height (m)	Table Angle (Degree)	Raw Value (dBuV)	Correction Factor (dB/m)
1	#5647.56	55.8 PK	68.2	-12.4	3.77 H	265	50.1	5.7
2	*5785.00	120.2 PK			3.77 H	265	114.3	5.9
3	*5785.00	109.0 AV			3.77 H	265	103.1	5.9
4	#5926.69	54.6 PK	68.2	-13.6	3.77 H	265	48.2	6.4
5	11570.00	58.4 PK	74.0	-15.6	2.92 H	360	41.3	17.1
6	11570.00	48.5 AV	54.0	-5.5	2.92 H	360	31.4	17.1
7	#17355.00	65.4 PK	68.2	-2.8	1.52 H	356	44.3	21.1

Remarks:

1. Emission Level(dBuV/m) = Raw Value(dBuV) + Correction Factor(dB/m)
2. Correction Factor(dB/m) = Antenna Factor(dB/m) + Cable Factor(dB) – Pre-Amplifier Factor(dB)
3. Margin value = Emission Level – Limit value
4. The other emission levels were very low against the limit.
5. " * ": Fundamental frequency, the limit was restricted at the RF Output Power.
6. " # ": The radiated frequency is out of the restricted band.

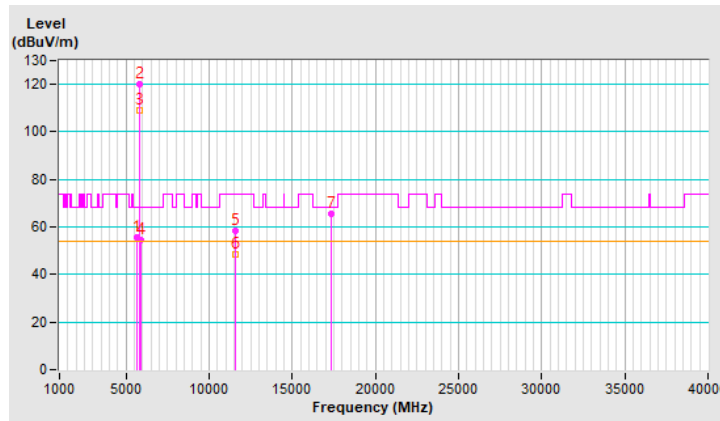

RF Mode	802.11ax (HE20)	Channel	CH 157 : 5785 MHz
Frequency Range	1 GHz ~ 40 GHz	Detector Function & Bandwidth	(PK) RB = 1 MHz, VB = 3 MHz (AV) RB = 1 MHz, VB = 10 Hz
Input Power	120 Vac, 60 Hz	Environmental Conditions	22°C, 71% RH
Tested By	Sampson Chen		

Antenna Polarity & Test Distance : Vertical at 3 m								
No	Frequency (MHz)	Emission Level (dBuV/m)	Limit (dBuV/m)	Margin (dB)	Antenna Height (m)	Table Angle (Degree)	Raw Value (dBuV)	Correction Factor (dB/m)
1	#5645.37	67.6 PK	68.2	-0.6	2.38 V	203	61.9	5.7
2	*5785.00	124.8 PK			2.38 V	203	118.9	5.9
3	*5785.00	113.4 AV			2.38 V	203	107.5	5.9
4	#5926.97	55.3 PK	68.2	-12.9	2.38 V	203	48.9	6.4
5	11570.00	57.8 PK	74.0	-16.2	2.57 V	272	40.7	17.1
6	11570.00	45.8 AV	54.0	-8.2	2.57 V	272	28.7	17.1
7	#17355.00	57.8 PK	68.2	-10.4	1.48 V	314	36.7	21.1

Remarks:

1. Emission Level(dBuV/m) = Raw Value(dBuV) + Correction Factor(dB/m)
2. Correction Factor(dB/m) = Antenna Factor(dB/m) + Cable Factor(dB) – Pre-Amplifier Factor(dB)
3. Margin value = Emission Level – Limit value
4. The other emission levels were very low against the limit.
5. " * " : Fundamental frequency, the limit was restricted at the RF Output Power.
6. " # " : The radiated frequency is out of the restricted band.

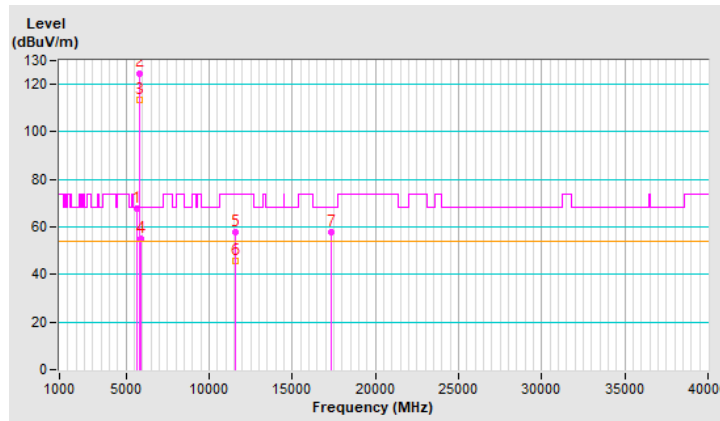

RF Mode	802.11ax (HE20)	Channel	CH 165 : 5825 MHz
Frequency Range	1 GHz ~ 40 GHz	Detector Function & Bandwidth	(PK) RB = 1 MHz, VB = 3 MHz (AV) RB = 1 MHz, VB = 10 Hz
Input Power	120 Vac, 60 Hz	Environmental Conditions	22°C, 71% RH
Tested By	Sampson Chen		

Antenna Polarity & Test Distance : Horizontal at 3 m

No	Frequency (MHz)	Emission Level (dBuV/m)	Limit (dBuV/m)	Margin (dB)	Antenna Height (m)	Table Angle (Degree)	Raw Value (dBuV)	Correction Factor (dB/m)
1	#5644.94	55.5 PK	68.2	-12.7	3.70 H	263	49.8	5.7
2	*5825.00	121.2 PK			3.70 H	263	115.2	6.0
3	*5825.00	109.8 AV			3.70 H	263	103.8	6.0
4	#5925.18	55.7 PK	68.2	-12.5	3.70 H	263	49.3	6.4
5	11650.00	58.1 PK	74.0	-15.9	2.99 H	360	41.4	16.7
6	11650.00	48.5 AV	54.0	-5.5	2.99 H	360	31.8	16.7
7	#17475.00	65.8 PK	68.2	-2.4	1.56 H	352	43.3	22.5

Remarks:

1. Emission Level(dBuV/m) = Raw Value(dBuV) + Correction Factor(dB/m)
2. Correction Factor(dB/m) = Antenna Factor(dB/m) + Cable Factor(dB) – Pre-Amplifier Factor(dB)
3. Margin value = Emission Level – Limit value
4. The other emission levels were very low against the limit.
5. " * " : Fundamental frequency, the limit was restricted at the RF Output Power.
6. " # " : The radiated frequency is out of the restricted band.

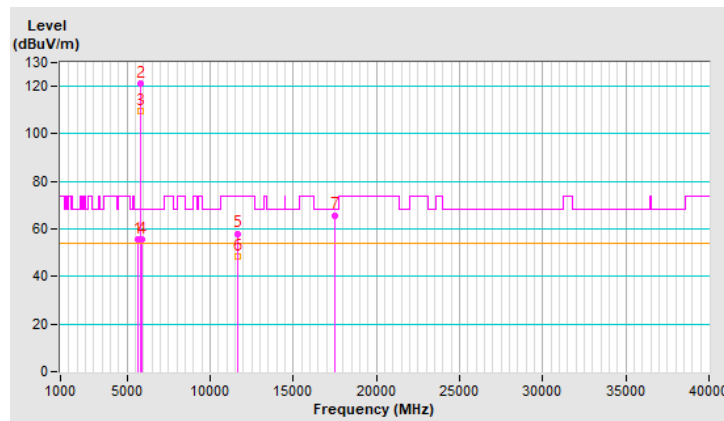

RF Mode	802.11ax (HE20)	Channel	CH 165 : 5825 MHz
Frequency Range	1 GHz ~ 40 GHz	Detector Function & Bandwidth	(PK) RB = 1 MHz, VB = 3 MHz (AV) RB = 1 MHz, VB = 10 Hz
Input Power	120 Vac, 60 Hz	Environmental Conditions	22°C, 71% RH
Tested By	Sampson Chen		

Antenna Polarity & Test Distance : Vertical at 3 m								
No	Frequency (MHz)	Emission Level (dBuV/m)	Limit (dBuV/m)	Margin (dB)	Antenna Height (m)	Table Angle (Degree)	Raw Value (dBuV)	Correction Factor (dB/m)
1	#5620.42	63.1 PK	68.2	-5.1	2.56 V	203	57.4	5.7
2	*5825.00	125.2 PK			2.56 V	203	119.2	6.0
3	*5825.00	113.9 AV			2.56 V	203	107.9	6.0
4	#5934.56	63.2 PK	68.2	-5.0	2.56 V	203	56.8	6.4
5	11650.00	58.4 PK	74.0	-15.6	2.62 V	257	41.7	16.7
6	11650.00	45.9 AV	54.0	-8.1	2.62 V	257	29.2	16.7
7	#17475.00	58.5 PK	68.2	-9.7	1.49 V	322	36.0	22.5

Remarks:

1. Emission Level(dBuV/m) = Raw Value(dBuV) + Correction Factor(dB/m)
2. Correction Factor(dB/m) = Antenna Factor(dB/m) + Cable Factor(dB) – Pre-Amplifier Factor(dB)
3. Margin value = Emission Level – Limit value
4. The other emission levels were very low against the limit.
5. " * " : Fundamental frequency, the limit was restricted at the RF Output Power.
6. " # " : The radiated frequency is out of the restricted band.

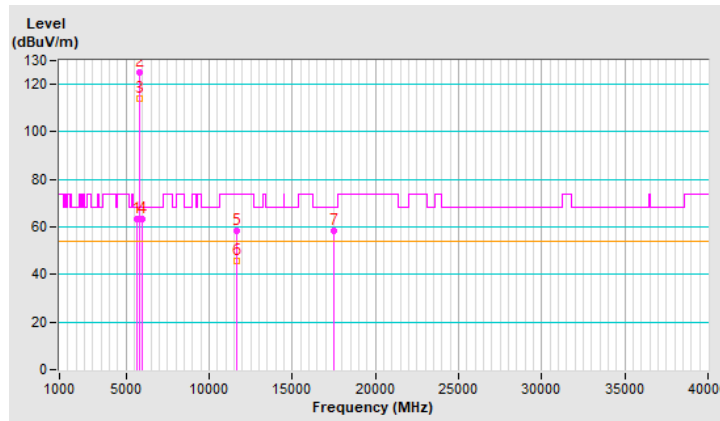

RF Mode	802.11ax (HE40)	Channel	CH 38 : 5190 MHz
Frequency Range	1 GHz ~ 40 GHz	Detector Function & Bandwidth	(PK) RB = 1 MHz, VB = 3 MHz (AV) RB = 1 MHz, VB = 10 Hz
Input Power	120 Vac, 60 Hz	Environmental Conditions	22°C, 71% RH
Tested By	Sampson Chen		

Antenna Polarity & Test Distance : Horizontal at 3 m

No	Frequency (MHz)	Emission Level (dBuV/m)	Limit (dBuV/m)	Margin (dB)	Antenna Height (m)	Table Angle (Degree)	Raw Value (dBuV)	Correction Factor (dB/m)
1	5150.00	63.9 PK	74.0	-10.1	3.12 H	289	58.7	5.2
2	5150.00	52.8 AV	54.0	-1.2	3.12 H	289	47.6	5.2
3	*5190.00	113.5 PK			3.12 H	289	108.4	5.1
4	*5190.00	104.2 AV			3.12 H	289	99.1	5.1
5	#10380.00	47.6 PK	68.2	-20.6	2.24 H	222	31.6	16.0
6	15570.00	59.8 PK	74.0	-14.2	1.53 H	357	42.4	17.4
7	15570.00	48.7 AV	54.0	-5.3	1.53 H	357	31.3	17.4

Remarks:

1. Emission Level(dBuV/m) = Raw Value(dBuV) + Correction Factor(dB/m)
2. Correction Factor(dB/m) = Antenna Factor(dB/m) + Cable Factor(dB) – Pre-Amplifier Factor(dB)
3. Margin value = Emission Level – Limit value
4. The other emission levels were very low against the limit.
5. " * " : Fundamental frequency, the limit was restricted at the RF Output Power.
6. " # " : The radiated frequency is out of the restricted band.

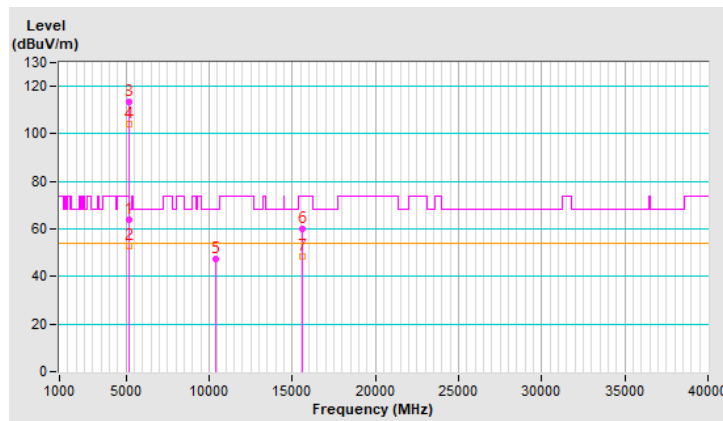

RF Mode	802.11ax (HE40)	Channel	CH 38 : 5190 MHz
Frequency Range	1 GHz ~ 40 GHz	Detector Function & Bandwidth	(PK) RB = 1 MHz, VB = 3 MHz (AV) RB = 1 MHz, VB = 10 Hz
Input Power	120 Vac, 60 Hz	Environmental Conditions	22°C, 71% RH
Tested By	Sampson Chen		

Antenna Polarity & Test Distance : Vertical at 3 m								
No	Frequency (MHz)	Emission Level (dBuV/m)	Limit (dBuV/m)	Margin (dB)	Antenna Height (m)	Table Angle (Degree)	Raw Value (dBuV)	Correction Factor (dB/m)
1	5147.16	65.1 PK	74.0	-8.9	2.76 V	193	59.9	5.2
2	5147.16	53.3 AV	54.0	-0.7	2.76 V	193	48.1	5.2
3	*5190.00	114.9 PK			2.76 V	193	109.8	5.1
4	*5190.00	105.2 AV			2.76 V	193	100.1	5.1
5	#10380.00	47.5 PK	68.2	-20.7	1.51 V	279	31.5	16.0
6	15570.00	57.3 PK	74.0	-16.7	2.54 V	327	39.9	17.4
7	15570.00	45.6 AV	54.0	-8.4	2.54 V	327	28.2	17.4

Remarks:

1. Emission Level(dBuV/m) = Raw Value(dBuV) + Correction Factor(dB/m)
2. Correction Factor(dB/m) = Antenna Factor(dB/m) + Cable Factor(dB) – Pre-Amplifier Factor(dB)
3. Margin value = Emission Level – Limit value
4. The other emission levels were very low against the limit.
5. " * " : Fundamental frequency, the limit was restricted at the RF Output Power.
6. " # " : The radiated frequency is out of the restricted band.

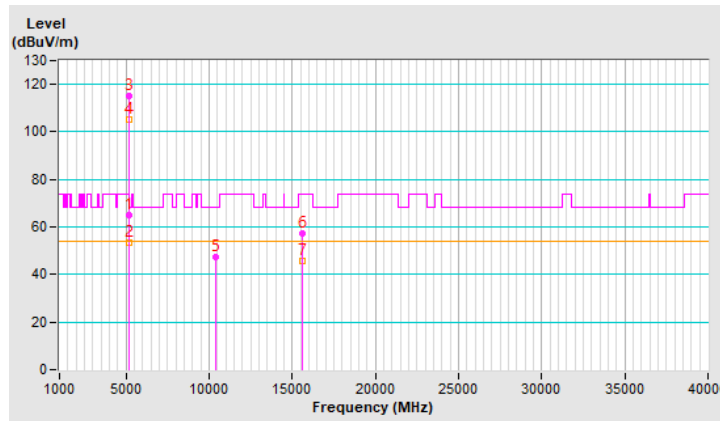

RF Mode	802.11ax (HE40)	Channel	CH 46 : 5230 MHz
Frequency Range	1 GHz ~ 40 GHz	Detector Function & Bandwidth	(PK) RB = 1 MHz, VB = 3 MHz (AV) RB = 1 MHz, VB = 10 Hz
Input Power	120 Vac, 60 Hz	Environmental Conditions	22°C, 71% RH
Tested By	Sampson Chen		

Antenna Polarity & Test Distance : Horizontal at 3 m								
No	Frequency (MHz)	Emission Level (dBuV/m)	Limit (dBuV/m)	Margin (dB)	Antenna Height (m)	Table Angle (Degree)	Raw Value (dBuV)	Correction Factor (dB/m)
1	5148.89	64.3 PK	74.0	-9.7	3.28 H	283	59.1	5.2
2	5148.89	52.6 AV	54.0	-1.4	3.28 H	283	47.4	5.2
3	*5230.00	117.5 PK			3.28 H	283	112.6	4.9
4	*5230.00	106.3 AV			3.28 H	283	101.4	4.9
5	#10460.00	47.2 PK	68.2	-21.0	2.26 H	218	31.0	16.2
6	15690.00	59.2 PK	74.0	-14.8	1.50 H	347	42.4	16.8
7	15690.00	48.4 AV	54.0	-5.6	1.50 H	347	31.6	16.8

Remarks:

1. Emission Level(dBuV/m) = Raw Value(dBuV) + Correction Factor(dB/m)
2. Correction Factor(dB/m) = Antenna Factor(dB/m) + Cable Factor(dB) – Pre-Amplifier Factor(dB)
3. Margin value = Emission Level – Limit value
4. The other emission levels were very low against the limit.
5. " * " : Fundamental frequency, the limit was restricted at the RF Output Power.
6. " # " : The radiated frequency is out of the restricted band.

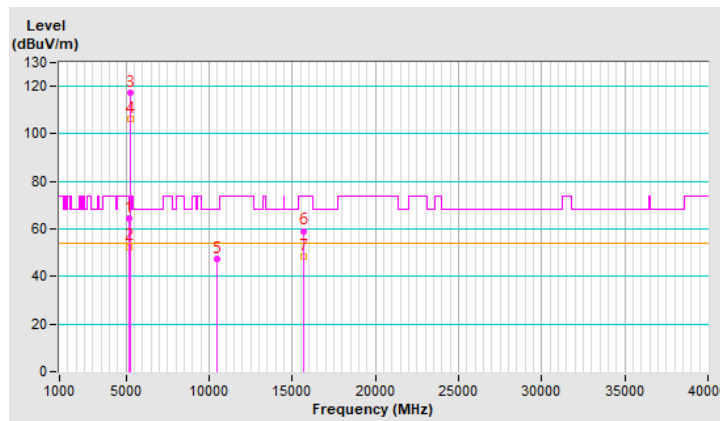

RF Mode	802.11ax (HE40)	Channel	CH 46 : 5230 MHz
Frequency Range	1 GHz ~ 40 GHz	Detector Function & Bandwidth	(PK) RB = 1 MHz, VB = 3 MHz (AV) RB = 1 MHz, VB = 10 Hz
Input Power	120 Vac, 60 Hz	Environmental Conditions	22°C, 71% RH
Tested By	Sampson Chen		

Antenna Polarity & Test Distance : Vertical at 3 m								
No	Frequency (MHz)	Emission Level (dBuV/m)	Limit (dBuV/m)	Margin (dB)	Antenna Height (m)	Table Angle (Degree)	Raw Value (dBuV)	Correction Factor (dB/m)
1	5147.45	64.8 PK	74.0	-9.2	2.73 V	193	59.6	5.2
2	5147.45	53.5 AV	54.0	-0.5	2.73 V	193	48.3	5.2
3	*5230.00	118.8 PK			2.73 V	193	113.9	4.9
4	*5230.00	107.7 AV			2.73 V	193	102.8	4.9
5	#10460.00	47.0 PK	68.2	-21.2	1.52 V	270	30.8	16.2
6	15690.00	57.3 PK	74.0	-16.7	2.58 V	313	40.5	16.8
7	15690.00	45.5 AV	54.0	-8.5	2.58 V	313	28.7	16.8

Remarks:

1. Emission Level(dBuV/m) = Raw Value(dBuV) + Correction Factor(dB/m)
2. Correction Factor(dB/m) = Antenna Factor(dB/m) + Cable Factor(dB) – Pre-Amplifier Factor(dB)
3. Margin value = Emission Level – Limit value
4. The other emission levels were very low against the limit.
5. " * " : Fundamental frequency, the limit was restricted at the RF Output Power.
6. " # " : The radiated frequency is out of the restricted band.

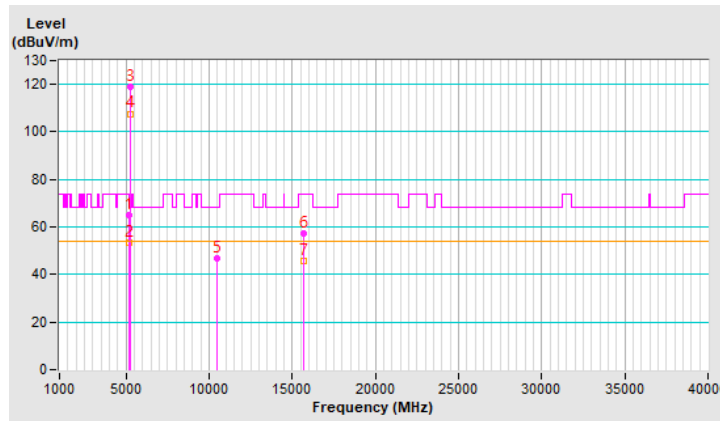

RF Mode	802.11ax (HE40)	Channel	CH 151 : 5755 MHz
Frequency Range	1 GHz ~ 40 GHz	Detector Function & Bandwidth	(PK) RB = 1 MHz, VB = 3 MHz (AV) RB = 1 MHz, VB = 10 Hz
Input Power	120 Vac, 60 Hz	Environmental Conditions	22°C, 71% RH
Tested By	Sampson Chen		

Antenna Polarity & Test Distance : Horizontal at 3 m

No	Frequency (MHz)	Emission Level (dBuV/m)	Limit (dBuV/m)	Margin (dB)	Antenna Height (m)	Table Angle (Degree)	Raw Value (dBuV)	Correction Factor (dB/m)
1	#5647.19	60.5 PK	68.2	-7.7	3.38 H	266	54.8	5.7
2	*5755.00	117.1 PK			3.38 H	266	111.2	5.9
3	*5755.00	105.3 AV			3.38 H	266	99.4	5.9
4	#5930.00	53.4 PK	68.2	-14.8	3.38 H	266	47.0	6.4
5	11510.00	47.8 PK	74.0	-26.2	2.28 H	244	30.5	17.3
6	11510.00	36.3 AV	54.0	-17.7	2.28 H	244	19.0	17.3
7	#17265.00	59.6 PK	68.2	-8.6	1.53 H	349	38.9	20.7

Remarks:

1. Emission Level(dBuV/m) = Raw Value(dBuV) + Correction Factor(dB/m)
2. Correction Factor(dB/m) = Antenna Factor(dB/m) + Cable Factor(dB) – Pre-Amplifier Factor(dB)
3. Margin value = Emission Level – Limit value
4. The other emission levels were very low against the limit.
5. " * " : Fundamental frequency, the limit was restricted at the RF Output Power.
6. " # " : The radiated frequency is out of the restricted band.

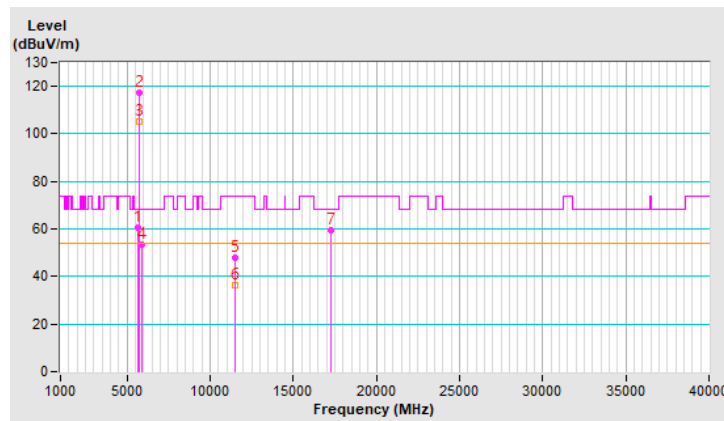

RF Mode	802.11ax (HE40)	Channel	CH 151 : 5755 MHz
Frequency Range	1 GHz ~ 40 GHz	Detector Function & Bandwidth	(PK) RB = 1 MHz, VB = 3 MHz (AV) RB = 1 MHz, VB = 10 Hz
Input Power	120 Vac, 60 Hz	Environmental Conditions	22°C, 71% RH
Tested By	Sampson Chen		

Antenna Polarity & Test Distance : Vertical at 3 m								
No	Frequency (MHz)	Emission Level (dBuV/m)	Limit (dBuV/m)	Margin (dB)	Antenna Height (m)	Table Angle (Degree)	Raw Value (dBuV)	Correction Factor (dB/m)
1	#5646.27	67.7 PK	68.2	-0.5	1.50 V	345	62.0	5.7
2	*5755.00	118.1 PK			1.50 V	345	112.2	5.9
3	*5755.00	108.0 AV			1.50 V	345	102.1	5.9
4	#5932.04	55.0 PK	68.2	-13.2	1.50 V	345	48.6	6.4
5	11510.00	47.4 PK	74.0	-26.6	1.52 V	275	30.1	17.3
6	11510.00	35.3 AV	54.0	-18.7	1.52 V	275	18.0	17.3
7	#17265.00	57.9 PK	68.2	-10.3	2.54 V	331	37.2	20.7

Remarks:

1. Emission Level(dBuV/m) = Raw Value(dBuV) + Correction Factor(dB/m)
2. Correction Factor(dB/m) = Antenna Factor(dB/m) + Cable Factor(dB) – Pre-Amplifier Factor(dB)
3. Margin value = Emission Level – Limit value
4. The other emission levels were very low against the limit.
5. " * " : Fundamental frequency, the limit was restricted at the RF Output Power.
6. " # " : The radiated frequency is out of the restricted band.

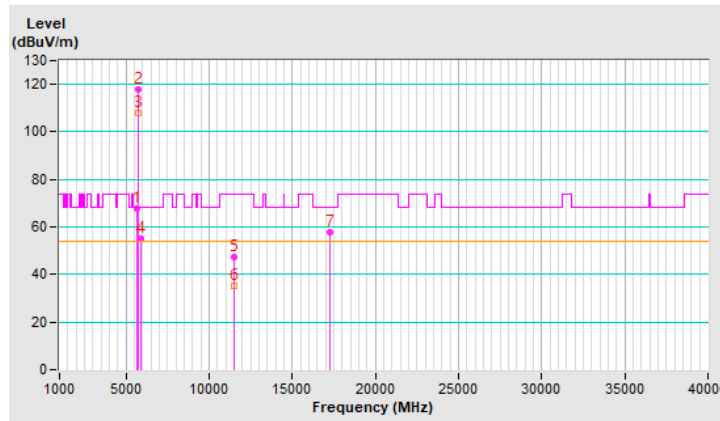

RF Mode	802.11ax (HE40)	Channel	CH 159 : 5795 MHz
Frequency Range	1 GHz ~ 40 GHz	Detector Function & Bandwidth	(PK) RB = 1 MHz, VB = 3 MHz (AV) RB = 1 MHz, VB = 10 Hz
Input Power	120 Vac, 60 Hz	Environmental Conditions	22°C, 71% RH
Tested By	Sampson Chen		

Antenna Polarity & Test Distance : Horizontal at 3 m								
No	Frequency (MHz)	Emission Level (dBuV/m)	Limit (dBuV/m)	Margin (dB)	Antenna Height (m)	Table Angle (Degree)	Raw Value (dBuV)	Correction Factor (dB/m)
1	#5650.00	60.2 PK	68.2	-8.0	3.40 H	250	54.5	5.7
2	*5795.00	116.6 PK			3.40 H	250	110.7	5.9
3	*5795.00	105.2 AV			3.40 H	250	99.3	5.9
4	#5930.11	54.9 PK	68.2	-13.3	3.40 H	250	48.5	6.4
5	11590.00	47.9 PK	74.0	-26.1	2.23 H	241	30.9	17.0
6	11590.00	35.9 AV	54.0	-18.1	2.23 H	241	18.9	17.0
7	#17385.00	59.2 PK	68.2	-9.0	1.55 H	360	38.1	21.1

Remarks:

1. Emission Level(dBuV/m) = Raw Value(dBuV) + Correction Factor(dB/m)
2. Correction Factor(dB/m) = Antenna Factor(dB/m) + Cable Factor(dB) – Pre-Amplifier Factor(dB)
3. Margin value = Emission Level – Limit value
4. The other emission levels were very low against the limit.
5. " * " : Fundamental frequency, the limit was restricted at the RF Output Power.
6. " # " : The radiated frequency is out of the restricted band.

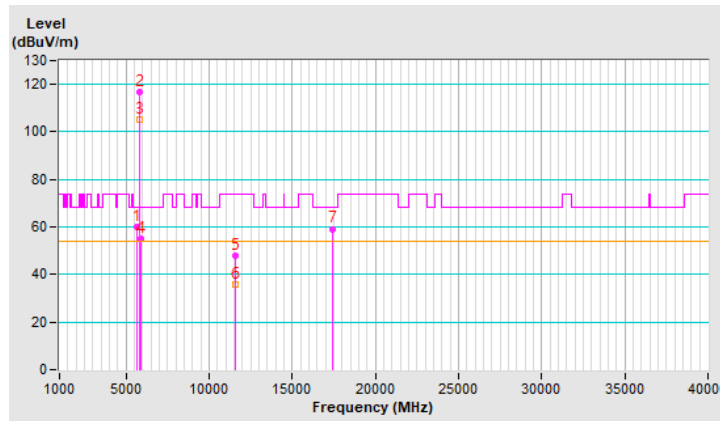

RF Mode	802.11ax (HE40)	Channel	CH 159 : 5795 MHz
Frequency Range	1 GHz ~ 40 GHz	Detector Function & Bandwidth	(PK) RB = 1 MHz, VB = 3 MHz (AV) RB = 1 MHz, VB = 10 Hz
Input Power	120 Vac, 60 Hz	Environmental Conditions	22°C, 71% RH
Tested By	Sampson Chen		

Antenna Polarity & Test Distance : Vertical at 3 m								
No	Frequency (MHz)	Emission Level (dBuV/m)	Limit (dBuV/m)	Margin (dB)	Antenna Height (m)	Table Angle (Degree)	Raw Value (dBuV)	Correction Factor (dB/m)
1	#5648.95	61.7 PK	68.2	-6.5	1.45 V	346	56.0	5.7
2	*5795.00	120.1 PK			1.45 V	346	114.2	5.9
3	*5795.00	108.2 AV			1.45 V	346	102.3	5.9
4	#5930.11	59.3 PK	68.2	-8.9	1.45 V	346	52.9	6.4
5	11590.00	46.9 PK	74.0	-27.1	1.51 V	269	29.9	17.0
6	11590.00	35.1 AV	54.0	-18.9	1.51 V	269	18.1	17.0
7	#17385.00	57.8 PK	68.2	-10.4	2.55 V	337	36.7	21.1

Remarks:

1. Emission Level(dBuV/m) = Raw Value(dBuV) + Correction Factor(dB/m)
2. Correction Factor(dB/m) = Antenna Factor(dB/m) + Cable Factor(dB) – Pre-Amplifier Factor(dB)
3. Margin value = Emission Level – Limit value
4. The other emission levels were very low against the limit.
5. " * ": Fundamental frequency, the limit was restricted at the RF Output Power.
6. " # ": The radiated frequency is out of the restricted band.

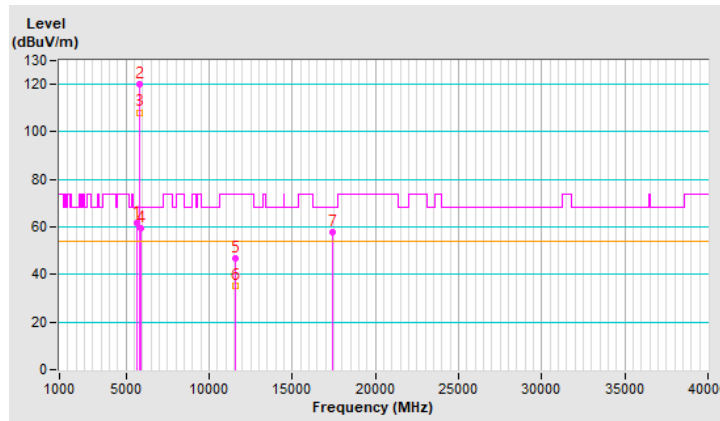

RF Mode	802.11ax (HE80)	Channel	CH 42 : 5210 MHz
Frequency Range	1 GHz ~ 40 GHz	Detector Function & Bandwidth	(PK) RB = 1 MHz, VB = 3 MHz (AV) RB = 1 MHz, VB = 10 Hz
Input Power	120 Vac, 60 Hz	Environmental Conditions	22°C, 71% RH
Tested By	Sampson Chen		

Antenna Polarity & Test Distance : Horizontal at 3 m

No	Frequency (MHz)	Emission Level (dBuV/m)	Limit (dBuV/m)	Margin (dB)	Antenna Height (m)	Table Angle (Degree)	Raw Value (dBuV)	Correction Factor (dB/m)
1	5145.58	62.6 PK	74.0	-11.4	3.28 H	284	57.4	5.2
2	5145.58	52.8 AV	54.0	-1.2	3.28 H	284	47.6	5.2
3	*5210.00	112.1 PK			3.28 H	284	107.1	5.0
4	*5210.00	100.8 AV			3.28 H	284	95.8	5.0
5	5354.02	55.5 PK	74.0	-18.5	3.28 H	284	50.5	5.0
6	5354.02	45.0 AV	54.0	-9.0	3.28 H	284	40.0	5.0
7	#10420.00	47.9 PK	68.2	-20.3	2.25 H	233	31.8	16.1
8	15630.00	58.7 PK	74.0	-15.3	1.48 H	360	41.6	17.1
9	15630.00	45.8 AV	54.0	-8.2	1.48 H	360	28.7	17.1

Remarks:

1. Emission Level(dBuV/m) = Raw Value(dBuV) + Correction Factor(dB/m)
2. Correction Factor(dB/m) = Antenna Factor(dB/m) + Cable Factor(dB) – Pre-Amplifier Factor(dB)
3. Margin value = Emission Level – Limit value
4. The other emission levels were very low against the limit.
5. " * " : Fundamental frequency, the limit was restricted at the RF Output Power.
6. " # " : The radiated frequency is out of the restricted band.

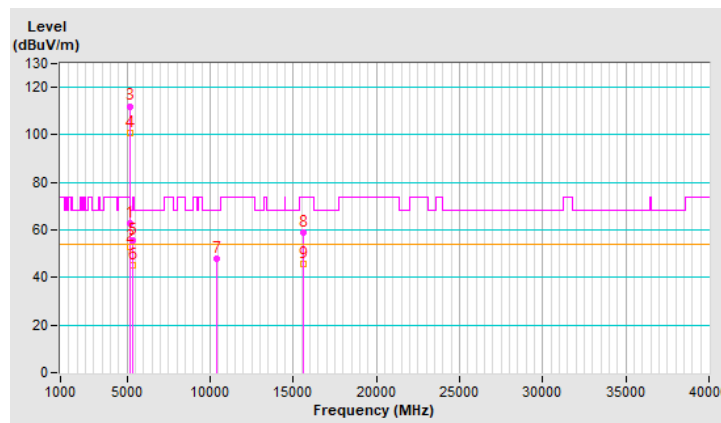

RF Mode	802.11ax (HE80)	Channel	CH 42 : 5210 MHz
Frequency Range	1 GHz ~ 40 GHz	Detector Function & Bandwidth	(PK) RB = 1 MHz, VB = 3 MHz (AV) RB = 1 MHz, VB = 10 Hz
Input Power	120 Vac, 60 Hz	Environmental Conditions	22°C, 71% RH
Tested By	Sampson Chen		

Antenna Polarity & Test Distance : Vertical at 3 m								
No	Frequency (MHz)	Emission Level (dBuV/m)	Limit (dBuV/m)	Margin (dB)	Antenna Height (m)	Table Angle (Degree)	Raw Value (dBuV)	Correction Factor (dB/m)
1	5150.00	64.9 PK	74.0	-9.1	2.87 V	338	59.7	5.2
2	5150.00	53.5 AV	54.0	-0.5	2.87 V	338	48.3	5.2
3	*5210.00	114.1 PK			2.87 V	338	109.1	5.0
4	*5210.00	101.9 AV			2.87 V	338	96.9	5.0
5	5352.77	57.4 PK	74.0	-16.6	2.87 V	338	52.4	5.0
6	5352.77	45.6 AV	54.0	-8.4	2.87 V	338	40.6	5.0
7	#10420.00	47.2 PK	68.2	-21.0	1.52 V	283	31.1	16.1
8	15630.00	54.3 PK	74.0	-19.7	2.58 V	328	37.2	17.1
9	15630.00	42.3 AV	54.0	-11.7	2.58 V	328	25.2	17.1

Remarks:

1. Emission Level(dBuV/m) = Raw Value(dBuV) + Correction Factor(dB/m)
2. Correction Factor(dB/m) = Antenna Factor(dB/m) + Cable Factor(dB) – Pre-Amplifier Factor(dB)
3. Margin value = Emission Level – Limit value
4. The other emission levels were very low against the limit.
5. " * ": Fundamental frequency, the limit was restricted at the RF Output Power.
6. " # ": The radiated frequency is out of the restricted band.

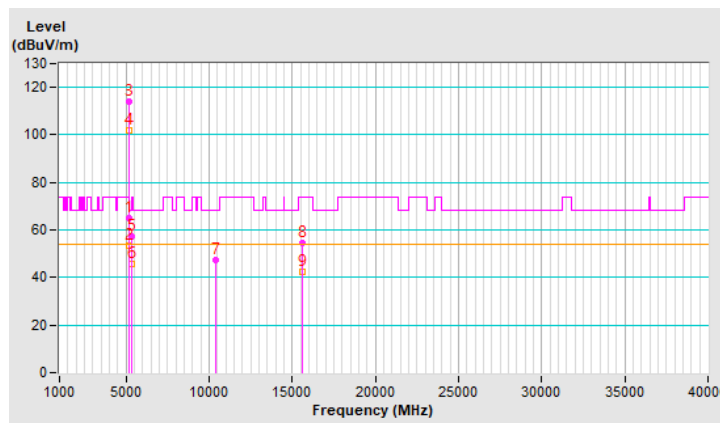

RF Mode	802.11ax (HE80)	Channel	CH 155 : 5775 MHz
Frequency Range	1 GHz ~ 40 GHz	Detector Function & Bandwidth	(PK) RB = 1 MHz, VB = 3 MHz (AV) RB = 1 MHz, VB = 10 Hz
Input Power	120 Vac, 60 Hz	Environmental Conditions	22°C, 71% RH
Tested By	Sampson Chen		

Antenna Polarity & Test Distance : Horizontal at 3 m								
No	Frequency (MHz)	Emission Level (dBuV/m)	Limit (dBuV/m)	Margin (dB)	Antenna Height (m)	Table Angle (Degree)	Raw Value (dBuV)	Correction Factor (dB/m)
1	#5645.74	59.4 PK	68.2	-8.8	3.25 H	236	53.7	5.7
2	*5775.00	110.2 PK			3.25 H	236	104.3	5.9
3	*5775.00	98.7 AV			3.25 H	236	92.8	5.9
4	#5929.86	52.4 PK	68.2	-15.8	3.25 H	236	46.0	6.4
5	11550.00	48.2 PK	74.0	-25.8	2.21 H	239	31.0	17.2
6	11550.00	36.5 AV	54.0	-17.5	2.21 H	239	19.3	17.2
7	#17325.00	59.3 PK	68.2	-8.9	1.45 H	349	38.1	21.2

Remarks:

1. Emission Level(dBuV/m) = Raw Value(dBuV) + Correction Factor(dB/m)
2. Correction Factor(dB/m) = Antenna Factor(dB/m) + Cable Factor(dB) – Pre-Amplifier Factor(dB)
3. Margin value = Emission Level – Limit value
4. The other emission levels were very low against the limit.
5. " * " : Fundamental frequency, the limit was restricted at the RF Output Power.
6. " # " : The radiated frequency is out of the restricted band.

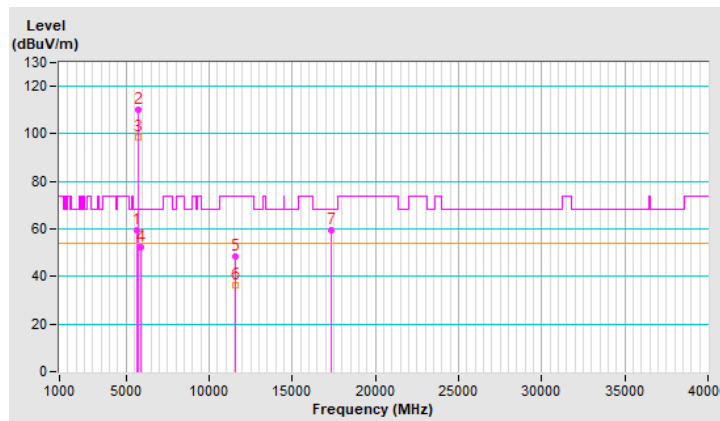

RF Mode	802.11ax (HE80)	Channel	CH 155 : 5775 MHz
Frequency Range	1 GHz ~ 40 GHz	Detector Function & Bandwidth	(PK) RB = 1 MHz, VB = 3 MHz (AV) RB = 1 MHz, VB = 10 Hz
Input Power	120 Vac, 60 Hz	Environmental Conditions	22°C, 71% RH
Tested By	Sampson Chen		

Antenna Polarity & Test Distance : Vertical at 3 m								
No	Frequency (MHz)	Emission Level (dBUV/m)	Limit (dBUV/m)	Margin (dB)	Antenna Height (m)	Table Angle (Degree)	Raw Value (dBUV)	Correction Factor (dB/m)
1	#5650.00	67.6 PK	68.2	-0.6	2.52 V	202	61.9	5.7
2	*5775.00	115.8 PK			2.52 V	202	109.9	5.9
3	*5775.00	104.0 AV			2.52 V	202	98.1	5.9
4	#5931.08	55.4 PK	68.2	-12.8	2.52 V	202	49.0	6.4
5	11550.00	47.1 PK	74.0	-26.9	1.45 V	274	29.9	17.2
6	11550.00	35.1 AV	54.0	-18.9	1.45 V	274	17.9	17.2
7	#17325.00	54.6 PK	68.2	-13.6	2.55 V	335	33.4	21.2

Remarks:

1. Emission Level(dBUV/m) = Raw Value(dBuV) + Correction Factor(dB/m)
2. Correction Factor(dB/m) = Antenna Factor(dB/m) + Cable Factor(dB) – Pre-Amplifier Factor(dB)
3. Margin value = Emission Level – Limit value
4. The other emission levels were very low against the limit.
5. " * " : Fundamental frequency, the limit was restricted at the RF Output Power.
6. " # " : The radiated frequency is out of the restricted band.

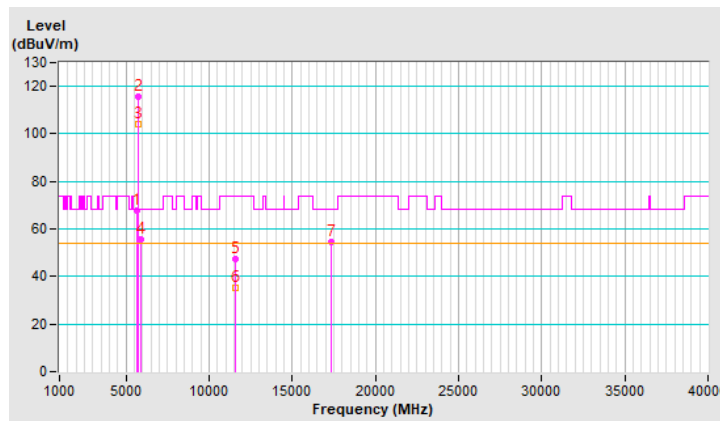



Plot of Band Edge

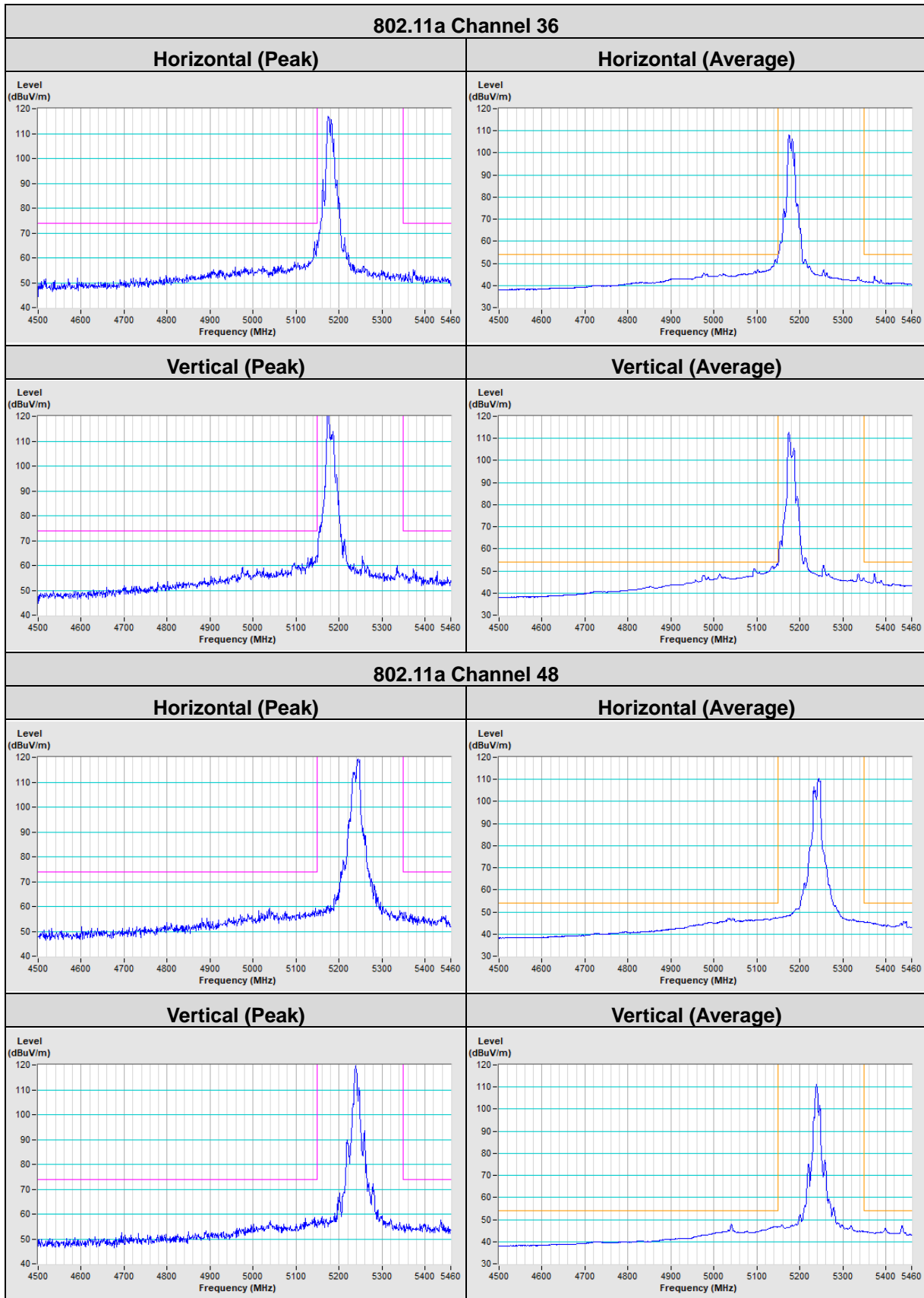

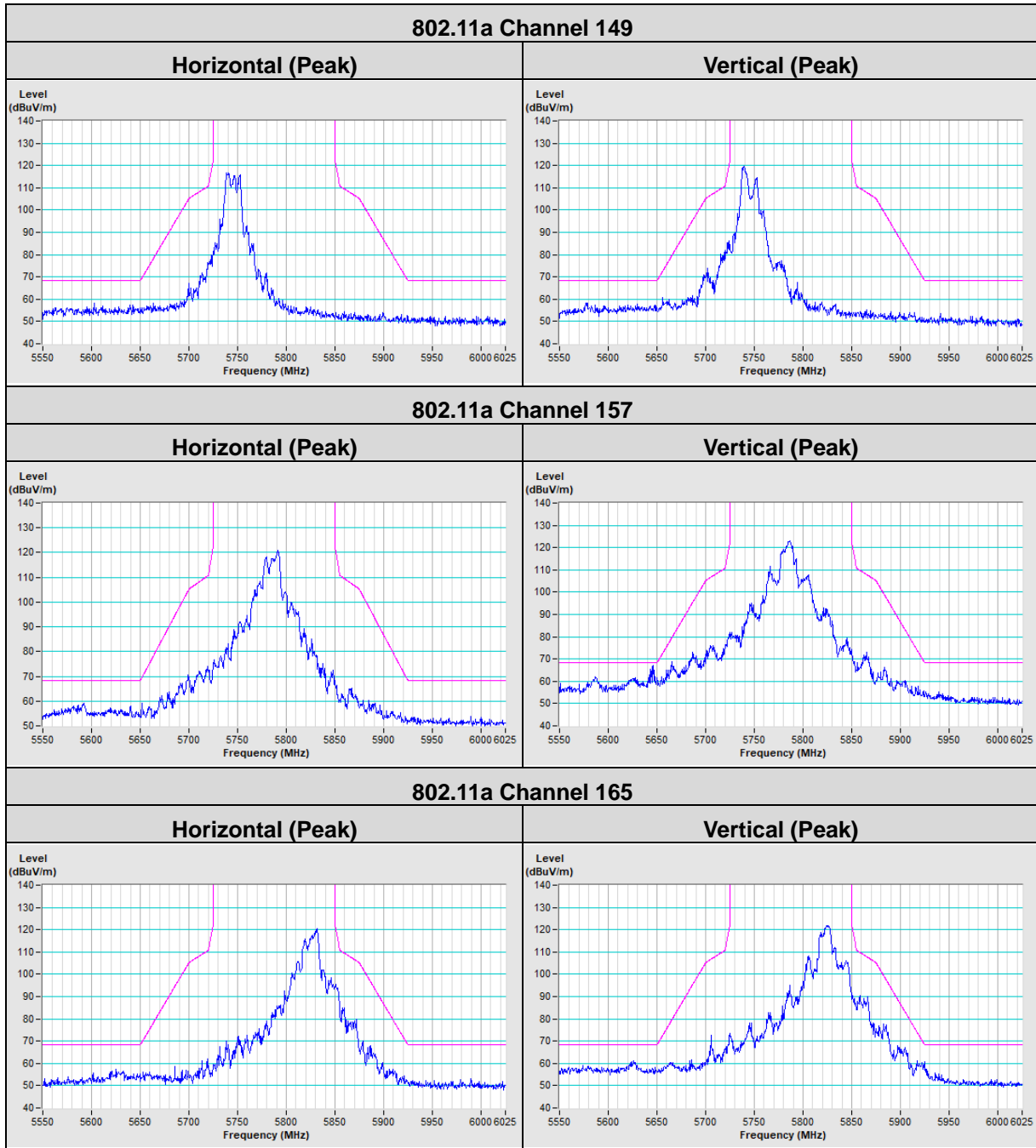

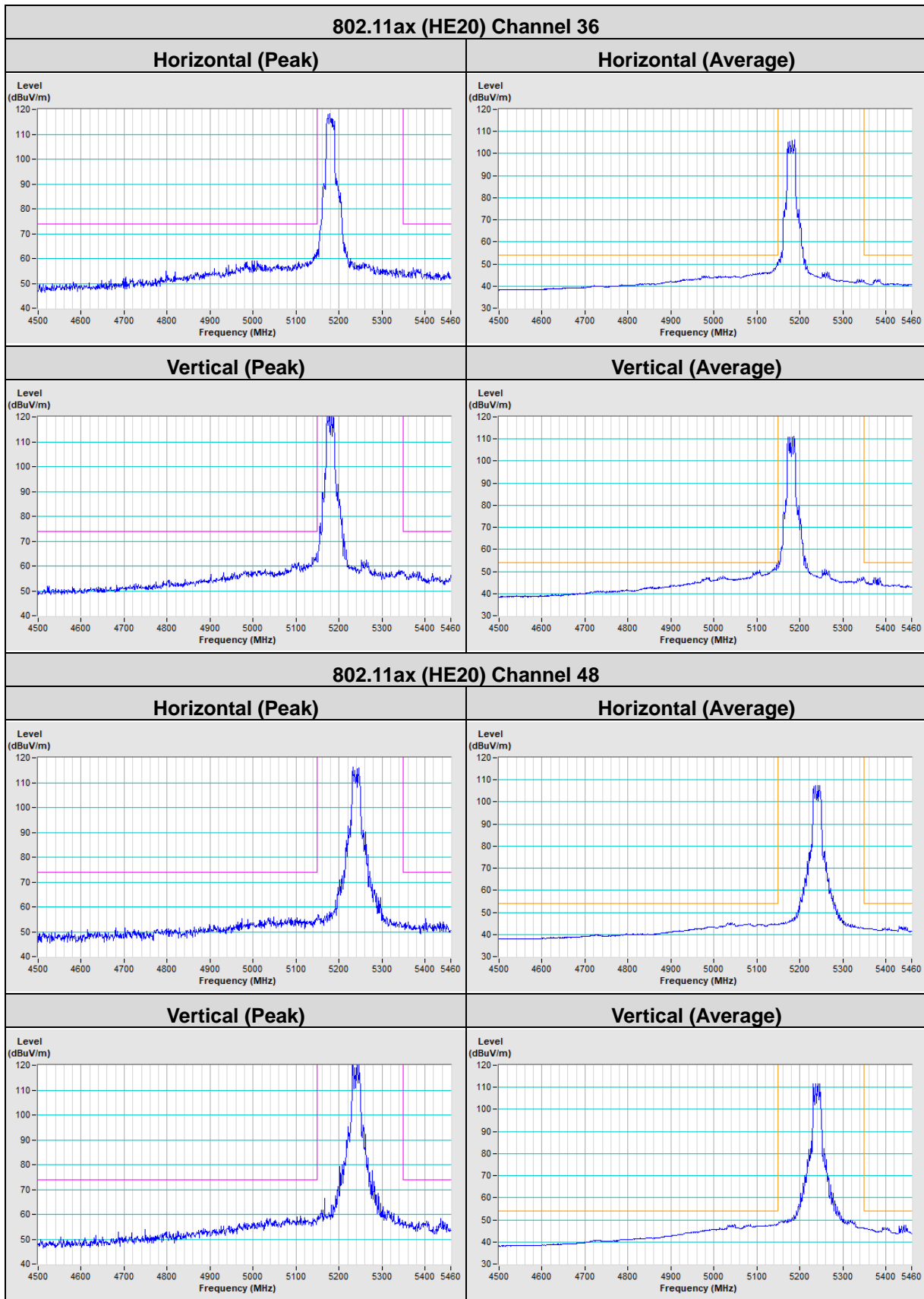

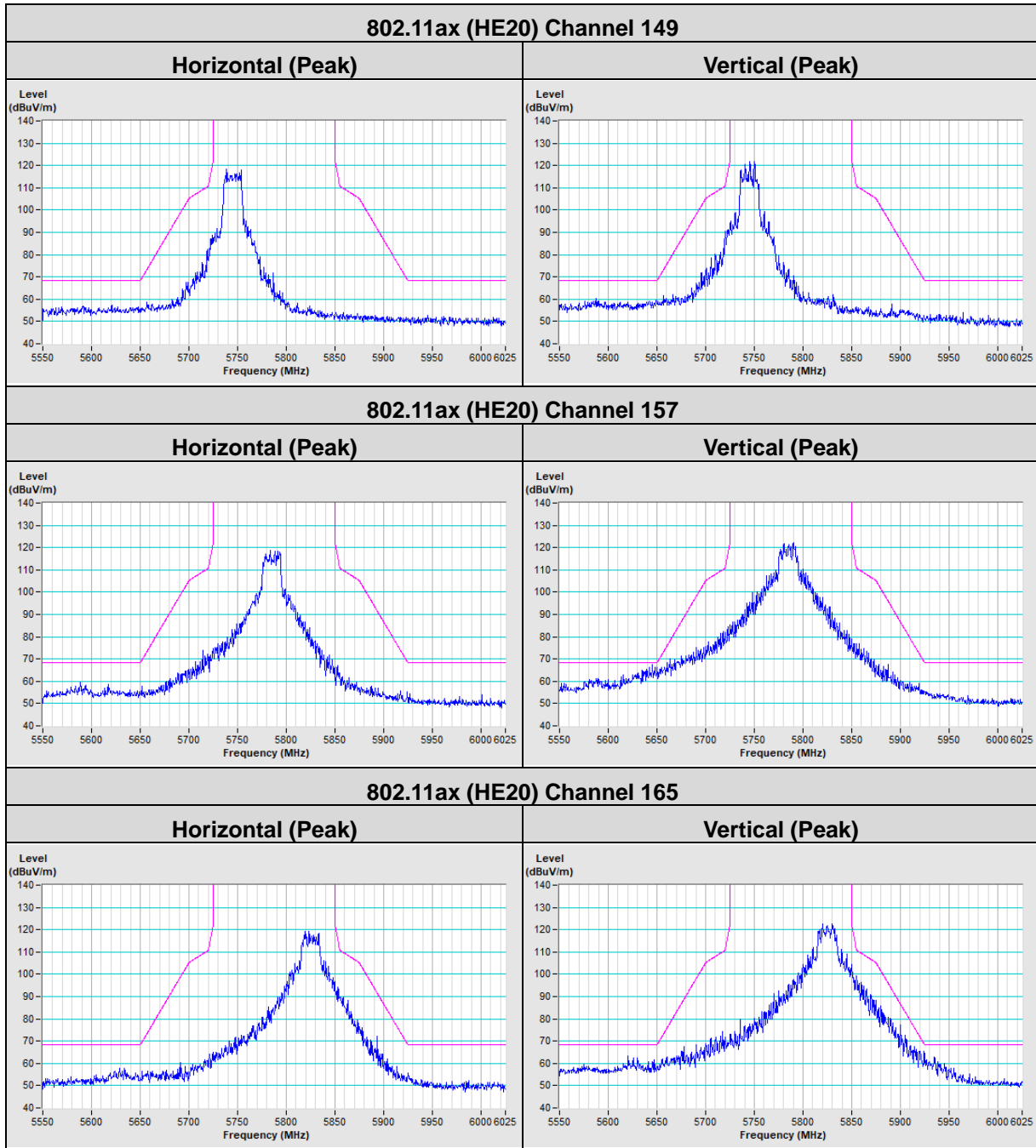

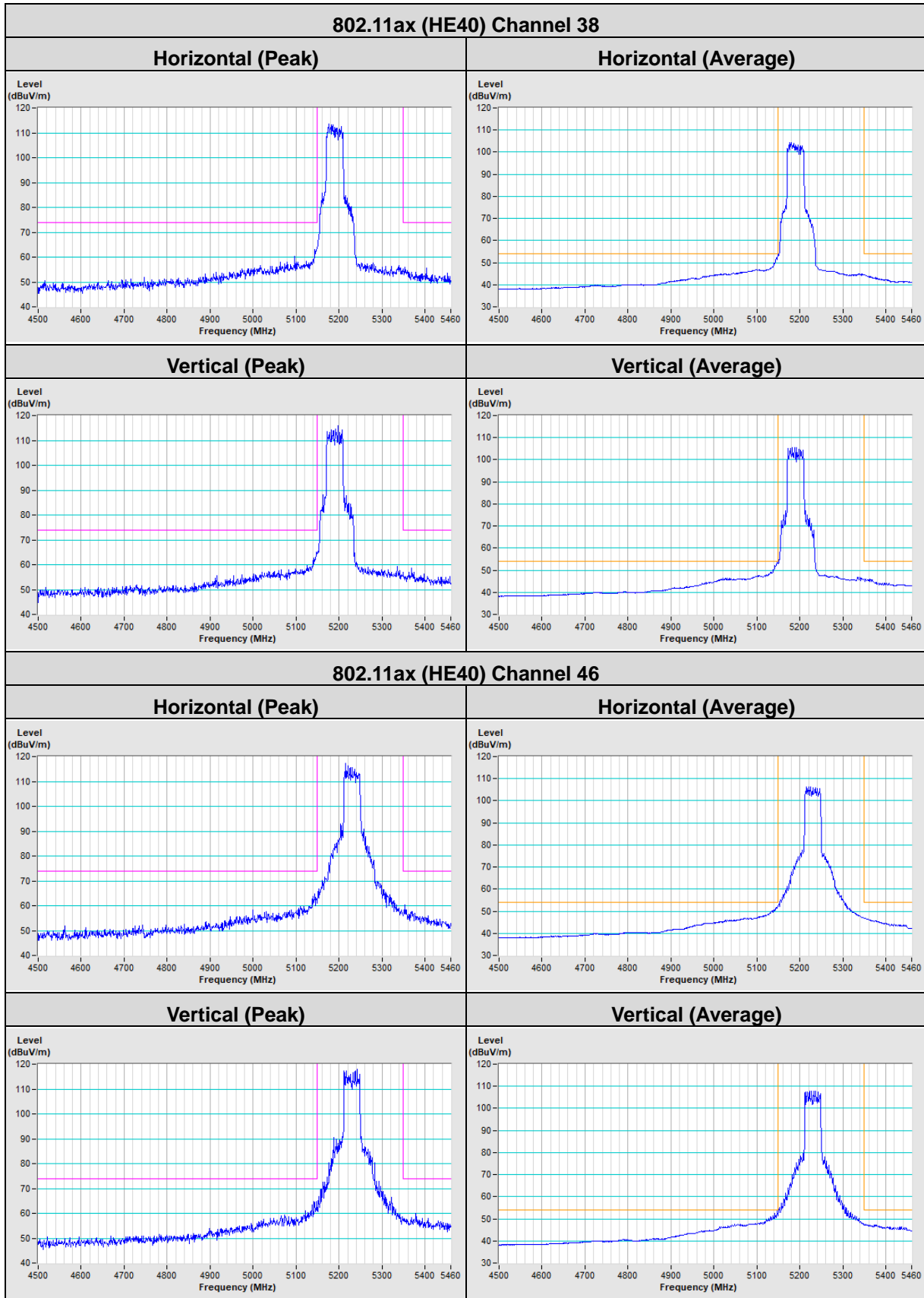

802.11ax (HE40) Channel 151

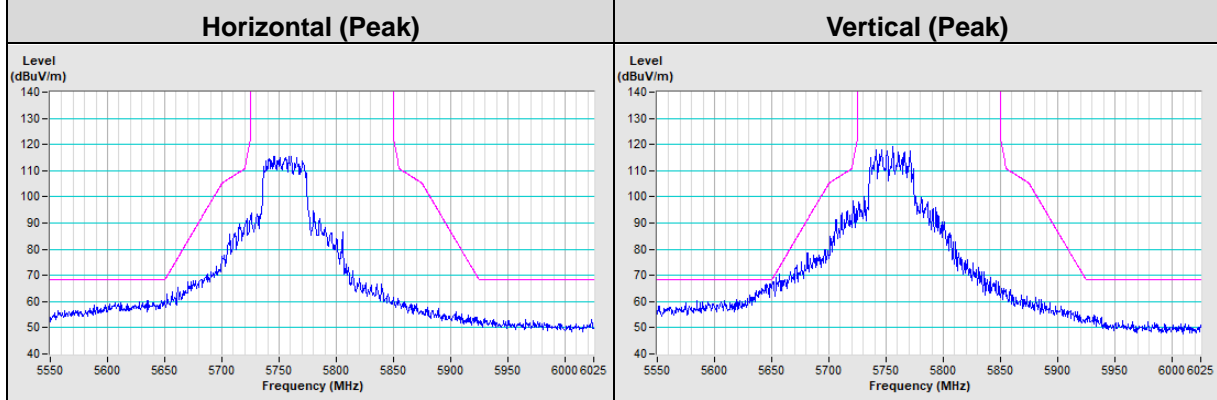

802.11ax (HE40) Channel 159

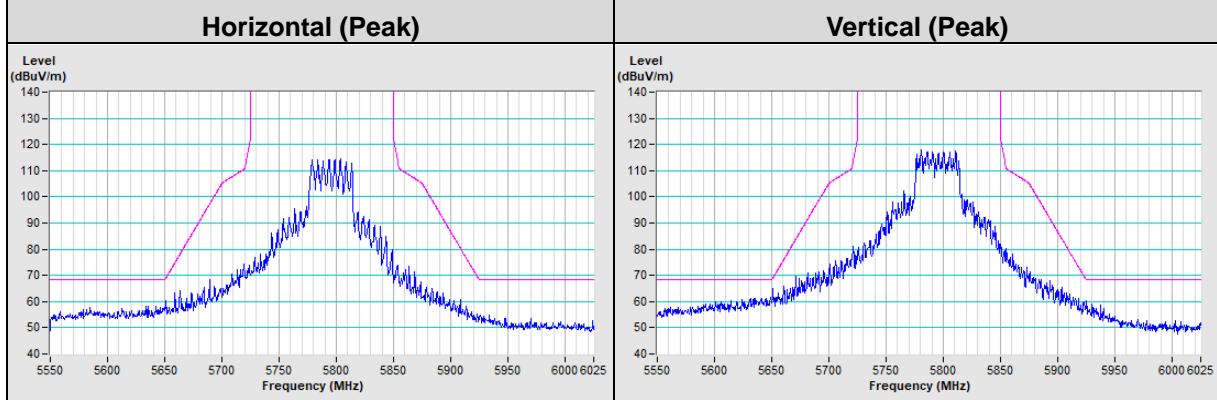

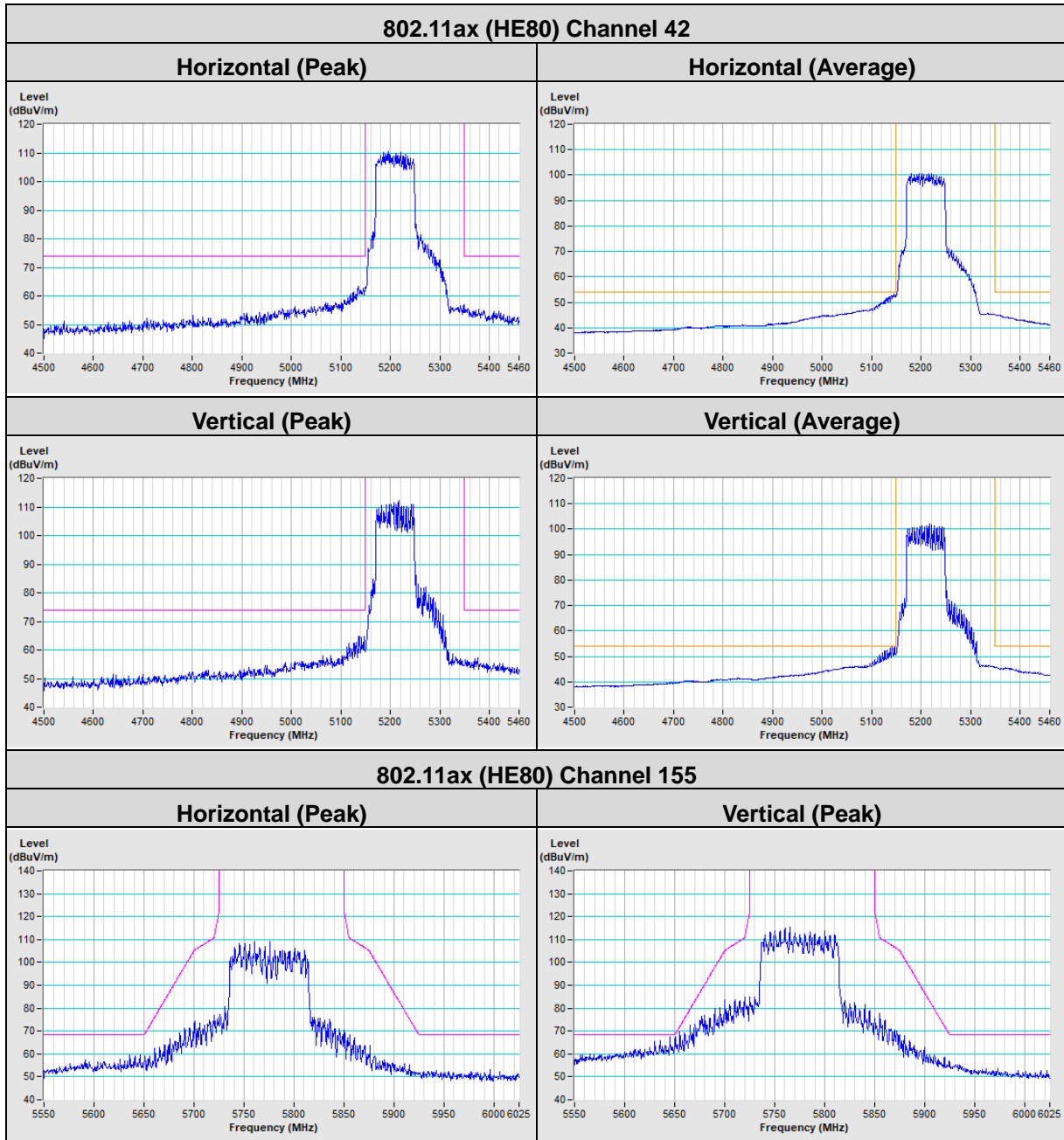

8 Pictures of Test Arrangements

Please refer to the attached file (Test Setup Photo)

9 Information of the Testing Laboratories

We, Bureau Veritas Consumer Products Services (H.K.) Ltd., Taoyuan Branch, were founded in 1988 to provide our best service in EMC, Radio, Telecom and Safety consultation. Our laboratories are FCC recognized accredited test firms and accredited according to ISO/IEC 17025.

If you have any comments, please feel free to contact us at the following:

Lin Kou EMC/RF Lab

Tel: 886-2-26052180

Fax: 886-2-26051924

Hsin Chu EMC/RF/Telecom Lab

Tel: 886-3-6668565

Fax: 886-3-6668323

Hwa Ya EMC/RF/Safety Lab

Tel: 886-3-3183232

Fax: 886-3-3270892

Email: service.adt@bureauveritas.com

Web Site: <http://ee.bureauveritas.com.tw>

The address and road map of all our labs can be found in our web site also.

--- END ---